

# STÛV 16-Z

## INSTALLATION MANUAL

Keep these instructions for future reference

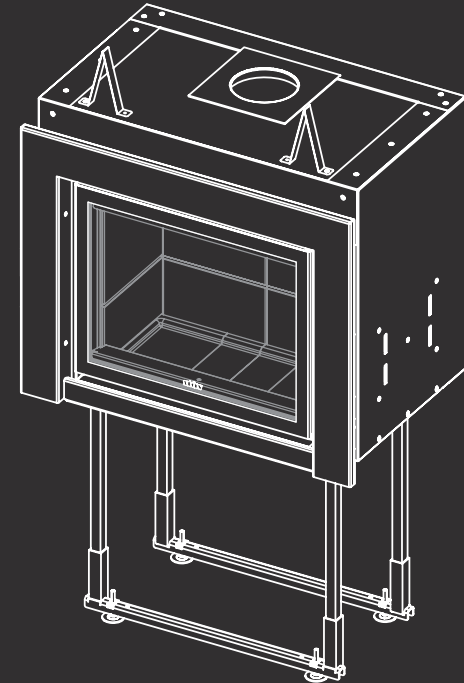
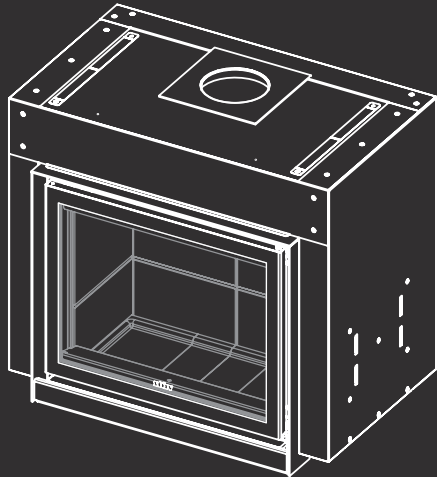

### REQUIRED TOOLS



Knife with retractable blade



Measuring tape



Crowbar



Level



Impact drill



Flat screwdriver



Grinder

### REQUIRED HARDWARE



7 mm hex socket



10 mm hex socket



10mm ratchet

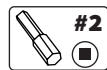

No. 2 square bit



No. 2 Phillips bit



5 mm hex bit



3 mm hex bit



Torx 20 bit



Torx 25 bit

### REQUIRED MATERIAL

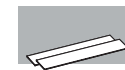

Wall and floor finishing

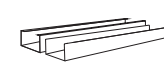

Metal framing

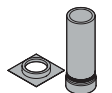

Chimney kit



Black no. 10 x 1/2" self-drilling screw



Wood screw #8

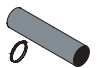

Ø4" clamping collar and flexible duct (option)



Stuv handle



Protective fabric or cardboard

## THANK YOU!

Thank you for choosing a Stûv wood-burning fireplace! It has been designed to provide maximum pleasure, comfort and safety. The utmost care has been taken in manufacturing this product. If, despite this, you still find a flaw, please contact your dealer.



## APPENDICES

This manual explains how to carry out a standard installation of a Stûv 16-cube and 16-H unit. To install a frame, the H base or the air damper, certain particularities, which are outlined in the additional manuals provided, must be followed as applicable. If the appendices are missing, contact our customer service department and request the manual(s) needed, mentioning the code under the icon(s) below.

**Look for these symbols.** They signal a change from the standard installation. It is very important to look through the installation manual and the additional manuals before getting started and to follow the instructions closely during installation to ensure that no steps are omitted.

Keep all instruction manuals provided close at hand to have all the information needed and to ensure proper and safe installation.



**AIR DAMPER**  
9310400019

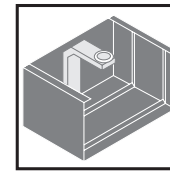

**H BASE**  
9310400022

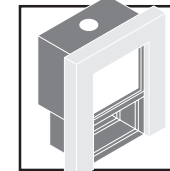

**COMBO**  
9310400016

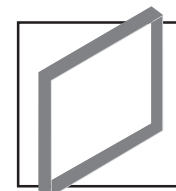

**THIN EDGE FRAME**  
9310400021

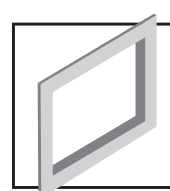

**PICTURE TYPE FRAME**  
9310400020



### IMPORTANT

Before installing this Stûv unit, contact the local authorities and/or your insurance company to obtain a building permit and inquire about all the requirements that need to be met.

For information on all the applicable regulatory requirements, contact your local fire department before starting the installation.

# TABLE OF CONTENTS

## 1. CERTIFICATION 4

1.1	Certification	5
1.2	Technical Specifications	5
1.3	Marking Labels	6
1.4	Safety Instructions	7

## 2. COMPONENTS 8

2.1	List of Components	9
2.2	Air Intake Accessories	11
2.3	Fireplace-Raising Accessories	12
2.4	Frames	13

## 3. DIMENSIONS 14

3.1	Stûv 16-Z Dimensions	15
3.2	Framework Characteristics	16
3.3	Hearth Opening	16
3.4	Floor Protection and R Value	17
3.5	Clearance	18
3.6	Risk Area	19
3.7	Base in Combustible Materials	19
3.8	Installing a 16-Z with an H Base	20
3.9	Fitted Television	21
3.10	Shelf Made of Combustible Material	21
3.11	Air Supply	22

## 4. INSTALLATION 24

4.1	Unpacking	25
4.2	Option: Adjustable Stands	27
4.3	Base Plate and Connection	29
4.4	Removing the Door	31
4.5	Moving the Fireplace	32
4.6	Connecting to the Smoke Outlet	33
4.7	Finishing	36
4.8	Adjusting the Door	37
4.9	Recap	39

## 5. CHIMNEY 40

5.1	Dimensions and Certification	41
5.2	Typical Installation	42
5.3	Masonry Chimney	43

## 6. USE 44

6.1	Fuel Selection	45
6.2	Starting the Fire	46
6.3	Reloading the Fire	48
6.4	Ash Removal	48

## 7. MAINTENANCE 49

7.1	Regular Maintenance	50
7.2	Replacing Components	51
7.3	Creosote and Chimney-Sweeping	54

## 8. WARRANTY 55

8.1	Warranty Details	56
8.2	Warranty Form	57

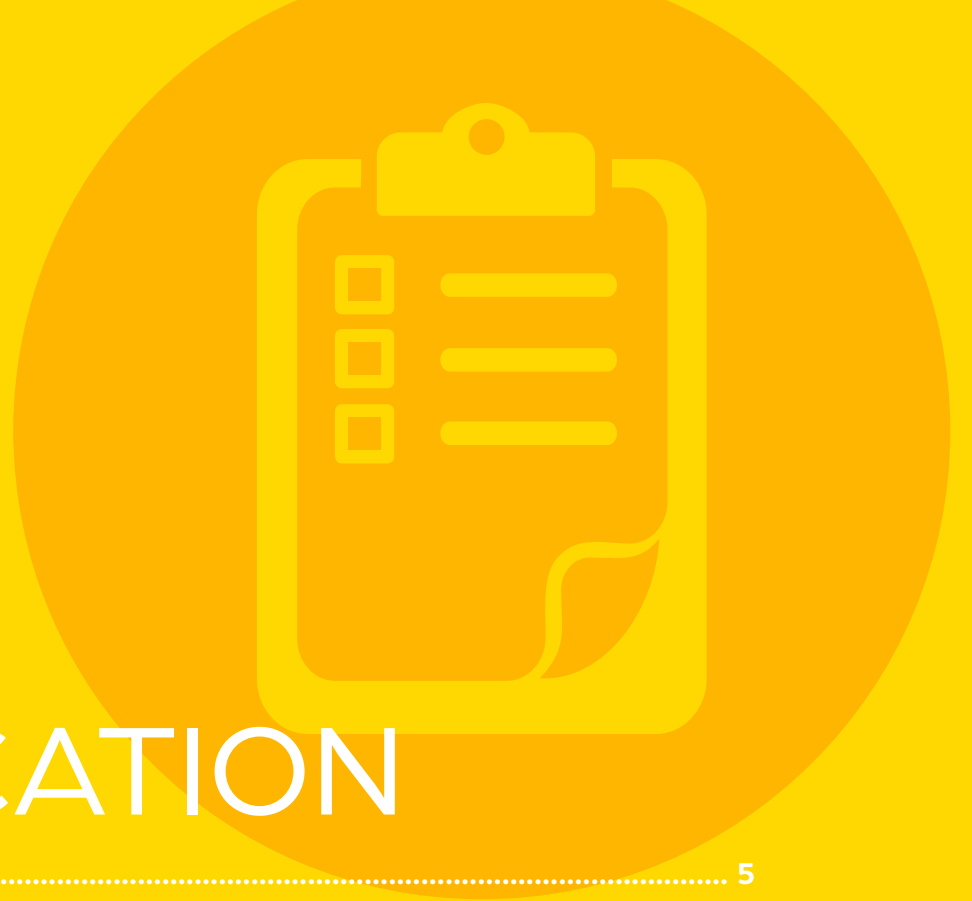

# 1

## CERTIFICATION

1.1	CERTIFICATION .....	5
1.2	TECHNICAL SPECIFICATIONS .....	5
1.3	MARKING LABELS .....	6
1.4	SAFETY INSTRUCTIONS .....	7

# 1.1 CERTIFICATION

16-58 & 16-68



16-78



**Tested and certified by CSA**  
according to these standards:

**ULC-S610:2018 & UL 127 - 9<sup>th</sup> Edition**  
**CSA B415.1-22**

**[16-58 Z & 16-68 Z] EPA 2020**

**[16-78 Z] EPA 2015 CRIB WOOD**

**6" ou 7" CHIMNEY: UL-103HT or ULC-S629**

**ULC-S610 : SECURITY CHIMNEY ASHT, ICC EXCEL**

This wood heater must be installed in accordance with standard **CSA B365 (Canada) or N.F.P.A. 211 (United States)**, the Installation Code for Solid-Fuel-Burning Appliances and Equipment, the applicable building code and standards applicable to the structure in which the insert will be installed.

The instructions for the installation of this wood heater comply with the above-mentioned standards. They must be closely followed to eliminate the risk of serious problems.

This Stûv unit must be installed by a qualified professional. Improper installation could result in a fire.

To reduce the risk of fire, read this manual carefully before installing or using the wood heater. If the installation instructions are not followed and the wood heater is improperly installed, the risk of incident increases. This can result in fire, property damage, bodily injury and even death.

Keep these instructions for future reference.

## NOTE

We strongly recommend that our products be installed and maintained by professionals certified by the Association des Professionnels du Chauffage if you are in Quebec or by Wood Energy Technical Training for the rest of Canada, and by the National Fireplace Institute in the United States.



# 1.2 TECHNICAL SPECIFICATIONS



STÛV 16-Z	16-58	16-68	16-78
Average fine particle emission rate, in g/h and g/MJ (output)	1.47 g/h 0.058 g/MJ	1.94 g/h 0.089 g/MJ	3.1 g/h 0.111 g/MJ
Fine particle emission rate in first hour, in g/h (output)	2.49 g/h	4.37 g/h	5.63 g/h
Average efficiency of the appliance (%)	70.3%	61.6%	66.6%
Minimum heat output rate (BTU/h)	22 432*	24 080*	23 256*
Maximum heat output rate (BTU/h)	27 015*	24 818*	28 765*
Max. log length	17"	21"	25"
Stûv 16-Z weight	232 lb.	261 lb.	288 lb.
Combustion chamber volume	1.59 pi <sup>3</sup>	1.94 pi <sup>3</sup>	2.19 pi <sup>3</sup>
Wood consumption/H	1.87 kg/h	2.12 kg/h	2.16 kg/h
Tested fuel	Crib wood		

This manual describes the installation and operation of the Stûv 16-Z wood heater. Models 16-58 and 16-68 meet the 2020 U.S. Environmental Protection Agency's fine particle emission limits for wood heaters sold after May 15, 2020.

\*Value calculated under specific test conditions (calculated according to standard CSA B415.1). The results are calculated according to the wood's high calorific value.

Efficiency can be affected by the appliance's location in the building, the geographic location, outdoor temperatures and the wood used. See the **FUEL SELECTION** section for more information.

# 1.3 MARKING LABELS



**MODELS/MODÈLES :**  
**STÜV 16-58 Z, 16-68 Z**  
**MANUFACTURED BY / FABRIQUÉ PAR :**  
**STÜV AMERICA 34, Boul. de l'Aéroport**  
 Bromont QC Canada J2L 1S6 [stuvamerica.com]

DATE OF MANUFACTURE / DATE DE FABRICATION	2024		2025		2026	
	JAN	FEB	MAR	JUN	JUL	AUG

LABEL NO. / NO. D'ÉTIQUETTE :

**STÜV 16\_000 000**



**CERTIFIED AND CONFORMS TO / CERTIFIÉ CONFORMÉMENT SELON :**  
 ULC-S610:2018 & UL 127 - 9th Edition, CSA B415.1-22, EPA 2020 CRIB WOOD 16-58 Z: 1.47 G/H (EPA 2020) | 16-68 Z: 1.94 G/H (EPA 2020)

**LISTED FACTORY BUILT STOVE FOR USE IN CANADA AND THE U.S.**  
 NOT SUITABLE FOR MOBILE HOME INSTALLATION

**POÈLE PRÉ-FABRIQUÉ HOMOLOGUÉ POUR LE CANADA ET LES É.-U.**  
 NE PAS INSTALLER DANS UNE MAISON MOBILE

**U.S. ENVIRONMENTAL PROTECTION AGENCY**

Certified to comply with 2020 particulate emission standards for single burn rate heaters. This single burn rate wood heater is not approved for use with a flue damper.

**AGENCE DE PROTECTION DE L'ENVIRONNEMENT É-U**

Conforme aux standards d'émissions pour foyers à combustion constante 2020. Ce foyer à vitesse de combustion constante n'est pas approuvé pour utilisation avec un clapet de fumée.

**CHIMNEY TYPE (See installation manual for appropriate choice)**

Use only a 6" or 7" insulated chimney listed per ULC-S629 or UL-103HT. ULC-S610 / SECURITY CHIMNEY ASHT, ICC EXCEL.

**TYPE DE CHEMINÉE (Voir la notice d'installation pour les bons choix)**

Utiliser uniquement une cheminée de 6" ou 7" isolée répertoriée selon la norme ULC-S629 ou UL-103HT. ULC-S610 / CHEMINÉE SÉCURITÉ ASHT, ICC EXCEL.

The minimum clearances indicated below are **from the insulated shell** and for all types of combustible materials (e.g., wood, drywall, etc.).

Les dégagements minimaux indiqués ci-dessous sont **à partir du caisson d'isolation** et pour tous matériaux combustibles (ex. : bois, gypse, etc.).

**SIDE WALL / PAROIS LATÉRALES :** 0"  
**BACK WALL / MUR ARRIÈRE :** 1/2" Stand-Off / Espaces  
**TOP OF UNIT / DESSUS DE L'UNITÉ :** 6" Stand-Off / Espaces

From under the unit to the ceiling / Du dessous de l'appareil jusqu'au plafond : 64"

From the glass to the floor / Floor protection (R-value) : Du bas de la vitre jusqu'au plancher / protection au sol (Facteur R) :

4 1/2" - 6 1/2" 2.56 R  
 6 1/2" - 8 1/2" 1.29 R  
 8 1/2" - 11 1/2" 0.28 R

11 1/2" + (No R value / Sans facteur R)  
 Projection: 16" (USA) / 18" (Canada)

For more details, consult the installation manual. Pour plus de détails, consultez la notice d'installation.

STÜV 16	16-58	16-68
Average particulate emission rate (output) / Émission particules fines moyenne (sortie)	1.47 g/h / 0.058g/hJ	1.94 g/h / 0.089g/hJ
Average efficiency of the appliance (%) / Rendement moyen de l'appareil (%)	70.3%	61.6%
Minimum heat output rate (BTU/h) / Puissance minimum (BTU/h)	22 432	24 080
Maximum heat output rate (BTU/h) / Puissance maximum (BTU/h)	27 015	24 818

Check STÜV's installation instructions for precautions required for passing a chimney or chimney connector through a combustible wall or ceiling and reference to local building code for details.

Se référer au code du bâtiment et aux instructions STÜV avant de traverser le mur ou le plafond avec votre conduit de cheminée.

MADE IN CANADA / FABRIQUÉ AU CANADA

- Fuel: Cord wood Only.
- Always close the door after the ignition.
- Floor must be protected as specified in the installation manual. For safe operation, install in accordance with the manufacturer's instructions.
- Replace glass only with Stüv's ceramic glass 4 mm thick.
- Components used with fireplace must be listed. See manual.
- Contact your local building or fire officials about restrictions and installation inspections in your area.
- Do not obstruct the combustion and convection air inlet and outlet in any case.
- Refer to manual for optional components.
- Do not connect this unit to a chimney flue serving another appliance.
- Inspect and clean chimney frequently - Under certain conditions of use, creosote buildup may occur rapidly.
- Do not overfire unit.
- Do not use a fireplace insert or other products not specified for use with this product.
- This wood heater needs periodic inspection and repair for proper operation. Consult the installation manual for further information.
- It is against federal regulations to operate this wood heater in a manner inconsistent with the operating instructions in the installation manual.
- **CAUTION:** When a fire is burning in the fireplace, fresh air must be supplied to the room where the fireplace is located. Failure to provide this may starve other fuel burning appliance from an adequate air supply.

- Combustible: Bois de corde seulement.
- Toujours fermer la porte après la période d'allumage.
- Le plancher doit être protégé tel que spécifié dans la notice d'installation. Pour un fonctionnement sécuritaire, installer conformément aux directives du fabricant.
- Remplacer le verre uniquement par un verre de céramique Stüv 4 mm d'épais.
- Les composantes utilisées dans l'appareil doivent être répertoriées. Voir notice d'installation.
- Communiquer avec les autorités locales en matière de construction ou d'incendie pour connaître les restrictions et inspections d'installation dans votre région.
- Ne pas obstruer les entrées et sorties d'air de combustion et de convection en aucun cas.
- Se référer à la notice d'installation pour la liste des composantes optionnelles.
- Ne pas relier cet appareil à un conduit de cheminée servant un autre appareil.
- Inspecter et nettoyer la cheminée fréquemment - Dans certaines conditions d'utilisation, l'accumulation de créosote peut se faire rapidement.
- Ne pas surchauffer l'appareil.
- Ne pas utiliser d'encastables ou autres produits non spécifiés avec ce foyer.
- Cet insert a besoin d'inspection et d'entretien périodiques pour sa bonne utilisation. Consultez la notice d'installation pour davantage d'informations.
- L'utilisation contraire à la notice d'installation représente une violation de la loi fédérale.
- **ATTENTION:** Lorsque le foyer brûle, un apport d'air supplémentaire doit être prévu dans la pièce. Un manque d'air d'appoint pourrait priver les autres appareils de combustion d'une alimentation d'air adéquate.

## ! CAUTION - ATTENTION !



HOT WHILE IN OPERATION DO NOT TOUCH, KEEP CHILDREN, CLOTHING AND FURNITURE AWAY. CONTACT MAY CAUSE SKIN BURNS. SEE NAME-PLATE AND INSTRUCTIONS.

CHAUD LORSQU'EN FONCTION. GARDER LES ENFANTS, VÊTEMENTS ET MEUBLES HORS DE PORTÉE. TOUCHER L'APPAREIL POURRAIT CAUSER DES BRÛLURES. VOIR LA FICHE SIGNALÉTIQUE ET INSTRUCTIONS.

DO NOT REMOVE THIS LABEL / NE PAS RETIRER CETTE ÉTIQUETTE

**MODEL/MODÈLE :**  
**STÜV 16-78 Z**  
**MANUFACTURED BY / FABRIQUÉ PAR :**  
**STÜV AMERICA 34, Boul. de l'Aéroport**  
 Bromont QC Canada J2L 1S6 [stuvamerica.com]

DATE OF MANUFACTURE / DATE DE FABRICATION	2024		2025		2026	
	JAN	FEB	MAR	JUN	JUL	AUG

LABEL NO. / NO. D'ÉTIQUETTE :

**STÜV 16\_000 000**



**CERTIFIED AND CONFORMS TO / CERTIFIÉ CONFORMÉMENT SELON :**  
 ULC-S610:2018 & UL 127 - 9th Edition, EPA 2015 CRIB WOOD, CSA B415.1-22 16-78 Z: 3.1 G/H (B415.1-22)

**LISTED FACTORY BUILT STOVE FOR USE IN CANADA AND THE U.S.**  
 NOT SUITABLE FOR MOBILE HOME INSTALLATION

**POÈLE PRÉ-FABRIQUÉ HOMOLOGUÉ POUR LE CANADA ET LES É.-U.**  
 NE PAS INSTALLER DANS UNE MAISON MOBILE

**U.S. ENVIRONMENTAL PROTECTION AGENCY**

Certified to comply with 2015 particulate emission standards for single burn rate heaters. Not approved for sale after May 15, 2020 (applicable for U.S. only). This single burn rate wood heater is not approved for use with a flue damper.

**AGENCE DE PROTECTION DE L'ENVIRONNEMENT É-U**

Conforme aux standards d'émissions pour foyers à combustion constante 2015. Non-approuvé pour la vente après le 15 mai 2020 (en vigueur seulement aux É.-U.). Ce foyer à vitesse de combustion constante n'est pas approuvé pour utilisation avec un clapet de fumée.

**CHIMNEY TYPE (See installation manual for appropriate choice)**

Use only a 6" or 7" insulated chimney listed per ULC-S629 or UL-103HT. ULC-S610 / SECURITY CHIMNEY ASHT, ICC EXCEL.

**TYPE DE CHEMINÉE (Voir la notice d'installation pour les bons choix)**

Utiliser uniquement une cheminée de 6" ou 7" isolée répertoriée selon la norme ULC-S629 ou UL-103HT. ULC-S610 / CHEMINÉE SÉCURITÉ ASHT, ICC EXCEL.

The minimum clearances indicated below are **from the insulated shell** and for all types of combustible materials (e.g., wood, drywall, etc.).

Les dégagements minimaux indiqués ci-dessous sont **à partir du caisson d'isolation** et pour tous matériaux combustibles (ex. : bois, gypse, etc.).

**SIDE WALL / PAROIS LATÉRALES :** 0"  
**BACK WALL / MUR ARRIÈRE :** 1/2" Stand-Off / Espaces  
**TOP OF UNIT / DESSUS DE L'UNITÉ :** 6" Stand-Off / Espaces

From under the unit to the ceiling / Du dessous de l'appareil jusqu'au plafond : 64"

From the glass to the floor / Floor protection (R-value) : Du bas de la vitre jusqu'au plancher / protection au sol (Facteur R) :

4 1/2" - 6 1/2" 2.56 R  
 6 1/2" - 8 1/2" 1.29 R  
 8 1/2" - 11 1/2" 0.28 R

11 1/2" + (No R value / Sans facteur R)  
 Projection: 16" (USA) / 18" (Canada)

For more details, consult the installation manual. Pour plus de détails, consultez la notice d'installation.

STÜV 16	16-78
Average particulate emission rate (output) / Émission particules fines moyenne (sortie)	3.1 g/h / 0.111 g/hJ
Average efficiency of the appliance (%) / Rendement moyen de l'appareil (%)	66.6%
Minimum heat output rate (BTU/h) / Puissance minimum (BTU/h)	23 256
Maximum heat output rate (BTU/h) / Puissance maximum (BTU/h)	28 765

Check STÜV's installation instructions for precautions required for passing a chimney or chimney connector through a combustible wall or ceiling and reference to local building code for details.

Se référer au code du bâtiment et aux instructions STÜV avant de traverser le mur ou le plafond avec votre conduit de cheminée.

MADE IN CANADA / FABRIQUÉ AU CANADA

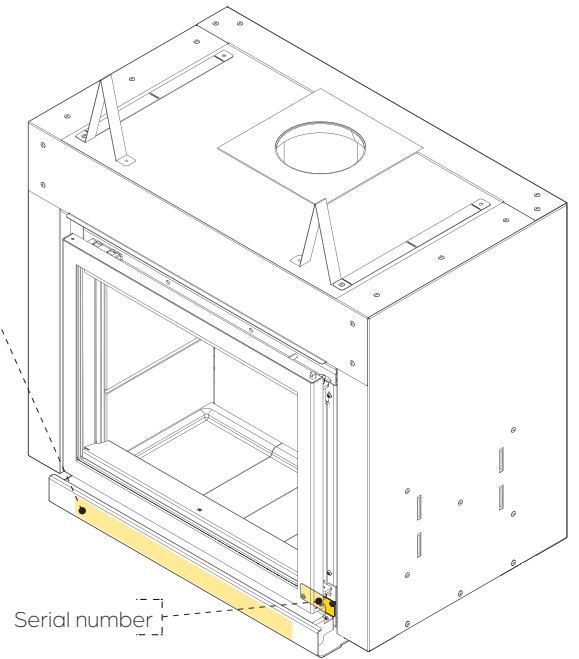

Marking label

Serial number

- Fuel: Cord wood Only.
- Always close the door after the ignition.
- Floor must be protected as specified in the installation manual. For safe operation, install in accordance with the manufacturer's instructions.
- Replace glass only with Stüv's ceramic glass 4 mm thick.
- Components used with fireplace must be listed. See installation manual.
- Contact your local building or fire officials about restrictions and installation inspections in your area.
- Do not obstruct the combustion and convection air inlet and outlet in any case.
- Refer to manual for optional components.
- Do not connect this unit to a chimney flue serving another appliance.
- Inspect and clean chimney frequently - Under certain conditions of use, creosote buildup may occur rapidly.
- Do not overfire unit.
- Do not use a fireplace insert or other products not specified for use with this product.
- This wood heater needs periodic inspection and repair for proper operation. Consult the installation manual for further information.
- It is against federal regulations to operate this wood heater in a manner inconsistent with the operating instructions in the installation manual.
- **CAUTION:** When a fire is burning in the fireplace, fresh air must be supplied to the room where the fireplace is located. Failure to provide this may starve other fuel burning appliance from an adequate air supply.

- Combustible: Bois de corde seulement.
- Toujours fermer la porte après la période d'allumage.
- Le plancher doit être protégé tel que spécifié dans la notice d'installation. Pour un fonctionnement sécuritaire, installer conformément aux directives du fabricant.
- Remplacer le verre uniquement par un verre de céramique Stüv 4 mm d'épais.
- Les composantes utilisées dans l'appareil doivent être répertoriées. Voir notice d'installation.
- Communiquer avec les autorités locales en matière de construction ou d'incendie pour connaître les restrictions et inspections d'installation dans votre région.
- Ne pas obstruer les entrées et sorties d'air de combustion et de convection en aucun cas.
- Se référer à la notice d'installation pour la liste des composantes optionnelles.
- Ne pas relier cet appareil à un conduit de cheminée servant un autre appareil.
- Inspecter et nettoyer la cheminée fréquemment - Dans certaines conditions d'utilisation, l'accumulation de créosote peut se faire rapidement.
- Ne pas surchauffer l'appareil.
- Ne pas utiliser d'encastables ou autres produits non spécifiés avec ce foyer.
- Cet insert a besoin d'inspection et d'entretien périodiques pour sa bonne utilisation. Consultez la notice d'installation pour davantage d'informations.
- L'utilisation contraire à la notice d'installation représente une violation de la loi fédérale.
- **ATTENTION:** Lorsque le foyer brûle, un apport d'air supplémentaire doit être prévu dans la pièce. Un manque d'air d'appoint pourrait priver les autres appareils de combustion d'une alimentation d'air adéquate.



## ! CAUTION - ATTENTION !

HOT WHILE IN OPERATION DO NOT TOUCH, KEEP CHILDREN, CLOTHING AND FURNITURE AWAY. CONTACT MAY CAUSE SKIN BURNS. SEE NAME-PLATE AND INSTRUCTIONS.

CHAUD LORSQU'EN FONCTION. GARDER LES ENFANTS, VÊTEMENTS ET MEUBLES HORS DE PORTÉE. TOUCHER L'APPAREIL POURRAIT CAUSER DES BRÛLURES. VOIR LA FICHE SIGNALÉTIQUE ET INSTRUCTIONS.

DO NOT REMOVE THIS LABEL / NE PAS RETIRER CETTE ÉTIQUETTE



## ! WARNING

1. It is essential that this Stûv be installed by a qualified professional. For information on all the applicable regulatory requirements, contact the local fire department before beginning the work.
2. The instructions for the installation of this unit comply with the aforementioned standards. They must be closely followed to eliminate the risk of serious problems. Any use contrary to the installation manual is a violation of federal law.
3. Improper installation of this Stûv unit could result in a fire. To reduce the risk of fire, follow the installation instructions to the letter. Failure to follow the instructions in this manual may result in property damage, bodily injury and even death.
4. Any modifications made to this unit may pose a hazard and will void the warranty. Should repairs be necessary, use only Stûv replacement parts.
5. Combustible materials such as firewood, wet clothing, etc. placed too close to the unit could catch fire. Objects placed in front of the unit must be kept at a distance of at least 48" (4') from the unit's glass face.
6. We recommend storing solid fuel in a clean, dry place. Do not place this type of fuel within the risk area or in the loading/ash removal area.
7. Do not operate this appliance with the door open.
8. Never leave the fireplace unattended when the door is open. Always close the door after the ignition period.
9. Do not burn garbage, plastic, petroleum-based products, gasoline, rubber, industrial solvents, flammable liquids like naphtha and motor oil, paper, cardboard, wood extracted from salt water and dried, painted wood or any substance that emits dense fumes and strong odours.
10. Do not overfire the unit. Raising the temperature outside of the combustion chamber can result in a chimney fire.
11. Never use chemicals or other liquids such as gasoline, gasoline-based lantern fuel, kerosene, charcoal lighter fluid or similar liquids to start or fuel a fire in the fireplace. Keep all such liquids away from the unit while it is in operation.
12. Make sure the home is equipped with a smoke and carbon monoxide monitor kept near the fireplace to prevent carbon monoxide poisoning. We recommend

keeping a type A or ABC fire extinguisher on hand in the event of a chimney fire.

13. Do not connect this appliance to a chimney pipe serving another appliance, or to a hot air distribution system.
14. This unit is hot when in use. Keep children, pets, clothing and furniture at a safe distance. Touching the appliance while it is in operation may cause burns.
15. Some parts of the fireplace can be very hot when operated at rated capacity. Do not allow the fireplace to heat to the point where parts become red.
16. Do not use a grate or other method to elevate the fuel. Burn firewood directly on the firebricks. Do not elevate the fire.
17. This appliance needs periodic inspections and maintenance for proper operation (minimum twice during the heating season).
18. Conduct regular maintenance of the fireplace as previously recommended.
19. Do not install this unit in a mobile home or in a transportable building.
20. The air inlets and outlets must remain unobstructed at all times.
21. The installation of the unit must comply with all local and national regulations.
22. Inspect and sweep the chimney frequently to ensure that it is in good condition. Creosote can build up quickly in certain operating conditions. Inspect and repair the chimney pipe as needed to ensure proper operation.
23. This wood heater has a manufacturer-set minimum low burn rate that must not be altered. It is against federal regulations to alter this setting or otherwise operate this wood heater in a manner inconsistent with operating instructions in this manual.

## ! IMPORTANT

This Stûv appliance must be registered to be covered by the warranty. Please refer to the last section of this document for guidance.

The self-adhesive **marking label** is located in the back of the flap and the riveted label with the **serial number** is located under the door, on the combustion chamber. They contain all the information needed to register this product. **See previous page.**

# 2

## COMPOSANTS



2.1	LIST OF COMPONENTS .....	9
2.2	AIR INTAKE ACCESSORIES .....	11
2.3	FIREPLACE-RAISING ACCESSORIES .....	12
2.4	FRAMES .....	13



## 2.1 LIST OF COMPONENTS

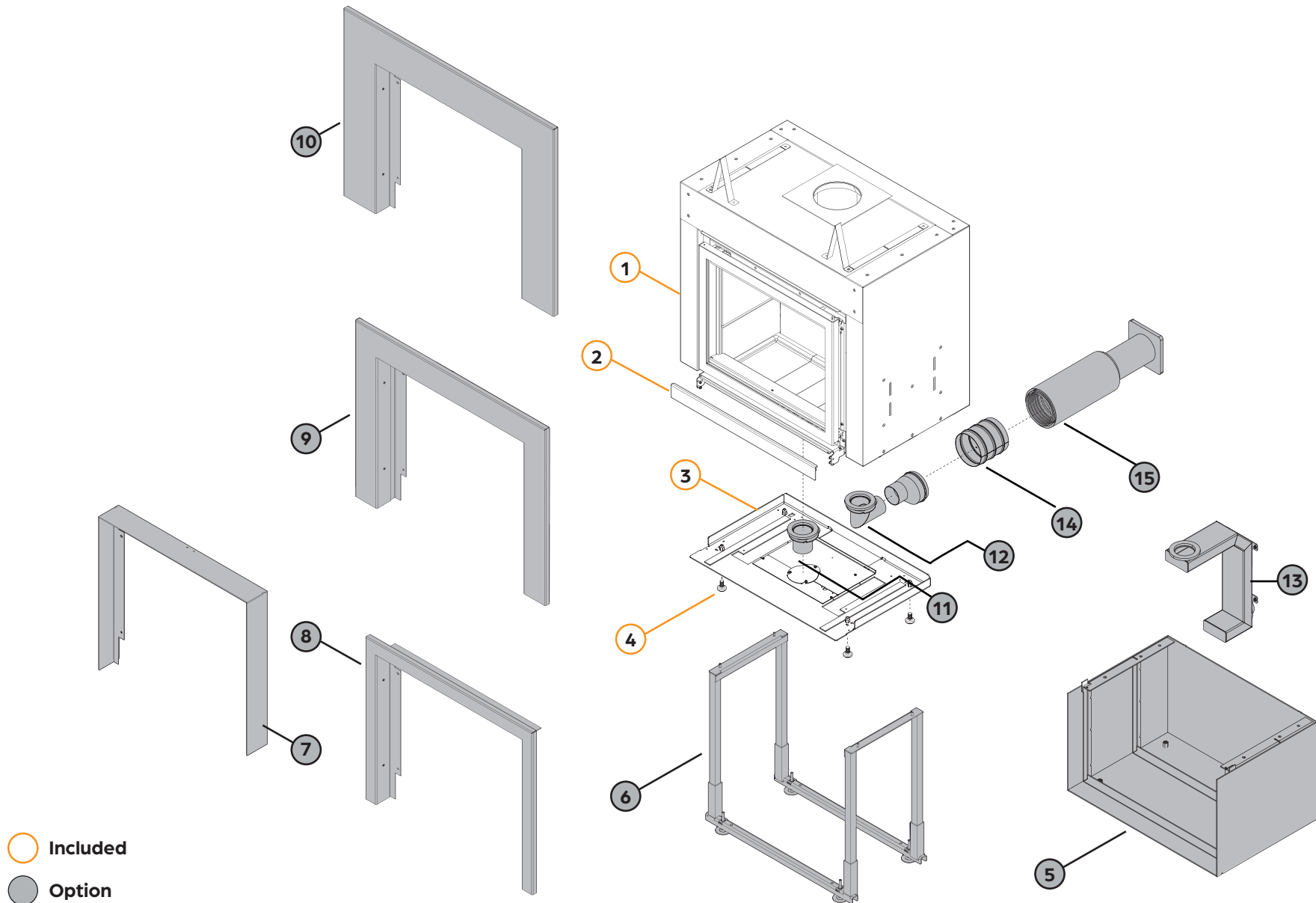

## 2.1 LIST OF COMPONENTS



16-58 Z

FW1011601201

#	DESCRIPTION	PRODUCT CODE	INCLUDED OR OPTION	Q <sup>TY</sup>
1	Fireplace	N/A	Included	1
2	Flap	PW1499762403	Included	1
3	Base plate	PW1499721100	Included	1
4	Leveling feet	PW1499700009	Included	1
5	H base	AW1301001200	Option	1
6	Adjustable stand	AW1300200100	Option	
7	Thin edge frame	AW1300411700	Required option	1
8	Picture type frame 2"	AW1300411400		
9	Picture type frame 4"	AW1300411401		
10	Picture type frame 6"	AW1300411402		

16-68 Z

FW1011601301

#	DESCRIPTION	PRODUCT CODE	INCLUDED OR OPTION	Q <sup>TY</sup>
1	Fireplace	N/A	Included	1
2	Flap	PW1499762503	Included	1
3	Base plate	PW1499723500	Included	1
4	Leveling feet	PW1499700009	Included	1
5	H base	AW1301001300	Option	1
6	Adjustable stand	AW1300200200	Option	
7	Thin edge frame	AW1300411800	Required option	1
8	Picture type frame 2"	AW1300411500		
9	Picture type frame 4"	AW1300411501		
10	Picture type frame 6"	AW1300411502		

16-78 Z

FW1011601401

#	DESCRIPTION	PRODUCT CODE	INCLUDED OR OPTION	Q <sup>TY</sup>
1	Fireplace	N/A	Included	1
2	Flap	PW1499762603	Included	1
3	Base plate	PW1499725900	Included	1
4	Leveling feet	PW1499700009	Included	1
5	H base	AW1301001400	Option	1
6	Adjustable stand	AW1300200300	Option	
7	Thin edge frame	AW1300411900	Required option	1
8	Picture type frame 2"	AW1300411600		
9	Picture type frame 4"	AW1300411601		
10	Picture type frame 6"	AW1300411602		

### ACCESSORIES

#	DESCRIPTION	PRODUCT CODE	INCLUDED OR OPTION	Q <sup>TY</sup>
11	Stûv 16-Z outside air intake connector	AW1200200500	Option	1
12	Stûv 16-Z outside air intake connector with <b>90° bend</b>	AW1200202900	Option	
13	H base outside air intake connector	AW1200200700	Option	
14	Outside air kit	AW1200200001	Option	1
15	4" air damper	AW1200100300	Option	1

## 2.2 AIR INTAKE ACCESSORIES



### CONNECTORS (STÜV 16-Z)

For outside air intake

Installation p.24

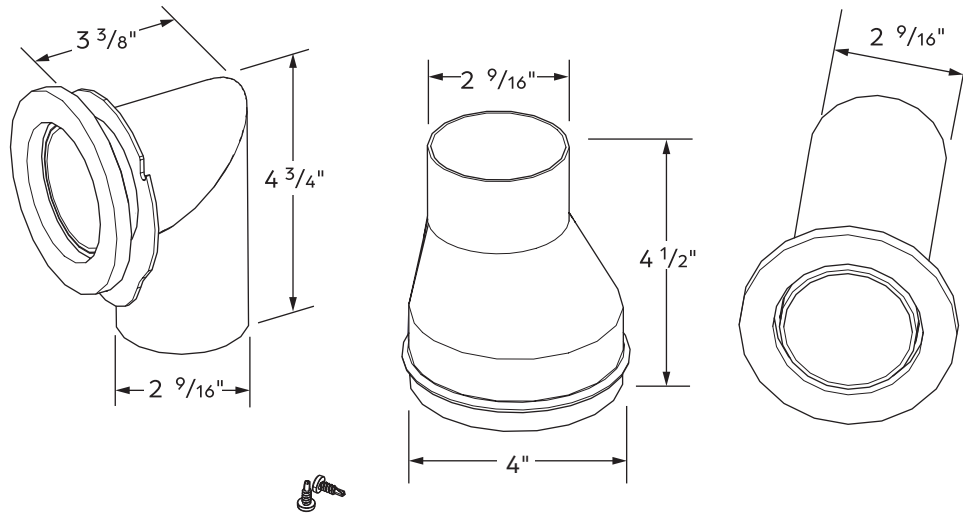

### AIR DAMPER

For outside air intake

Follow the instructions provided with the air damper.

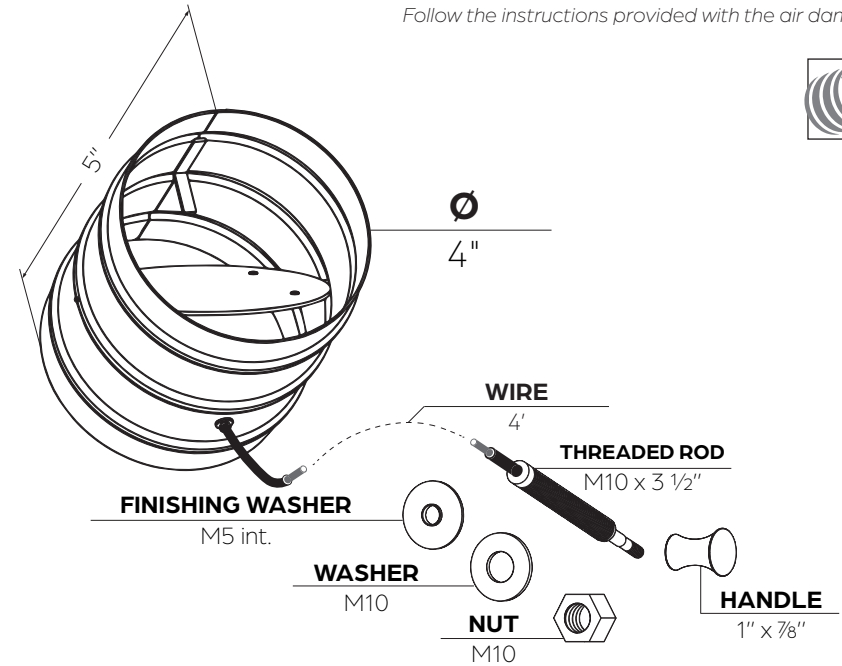

### CONNECTORS (H BASE)

For outside air intake

Follow the instructions provided with the H base.

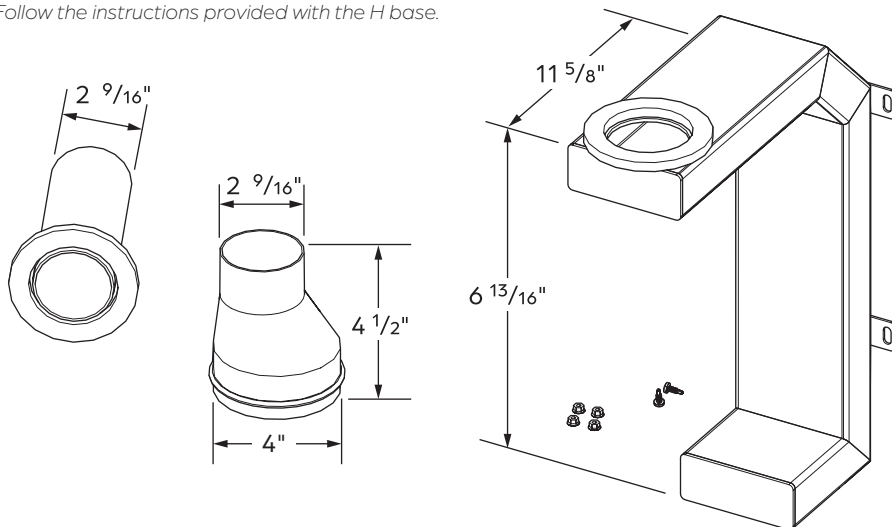

### OUTSIDE AIR KIT

Follow the instructions provided with the air damper.

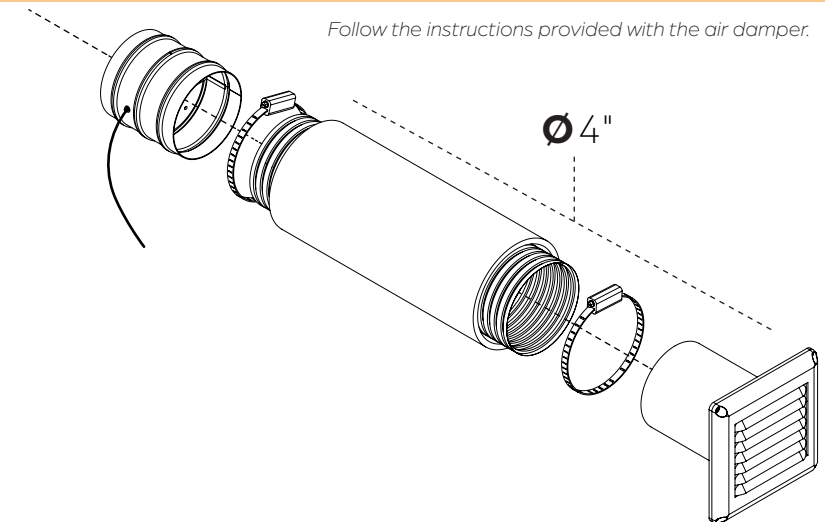

## 2.3 ACCESSOIRES OPTIONNELS



### ADJUSTABLE STAND

Installation p.23

STAND	CODE	R
16-58	AW1300200100	21 1/16"
16-68	AW1300200200	25 3/8"
16-78	AW1300200300	28 15/16"

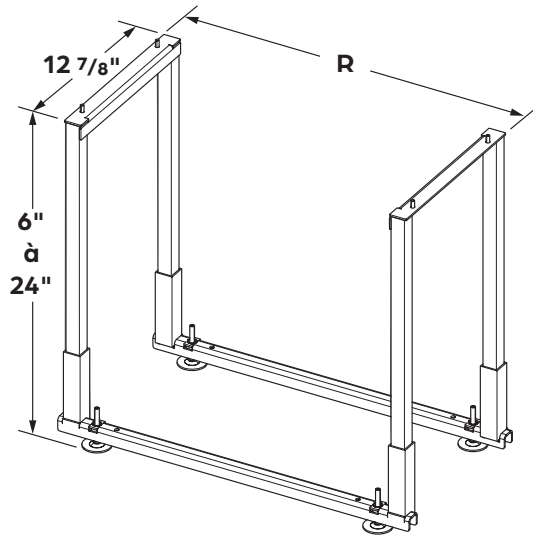

### H BASE



Follow the instructions provided with the H base

H BASE	CODE	U
16-58	AW1300200100	22 7/8"
16-68	AW1300200200	26 3/4"
16-78	AW1300200300	30 3/4"

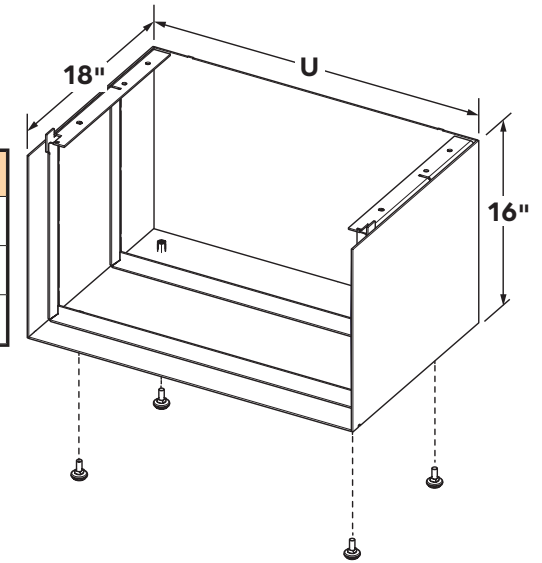

### THIN EDGE FRAME



Follow the instructions provided with the thin edge frame

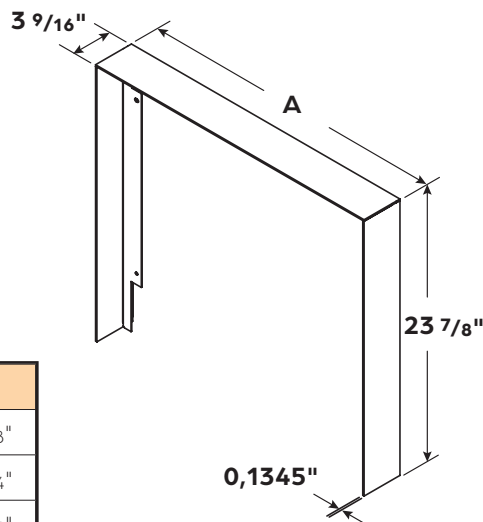

THIN EDGE	CODE	A
16-58	AW1300411700	22 7/8"
16-68	AW1300411800	26 3/4"
16-78	AW1300411900	30 3/4"

### PICTURE TYPE FRAME

2"	CODE	A	B
16-58	AW1300411400	26 3/8"	25 1/2"
16-68	AW1300411500	30 5/16"	
16-78	AW1300411600	34 1/4"	

4"	CODE	A	B
16-58	AW1300411401	30 5/16"	27 7/16"
16-68	AW1300411501	34 1/4"	
16-78	AW1300411601	38 3/16"	

6"	CODE	A	B
16-58	AW1300411402	34 1/4"	29 7/16"
16-68	AW1300411502	38 3/16"	
16-78	AW1300411602	42 1/8"	

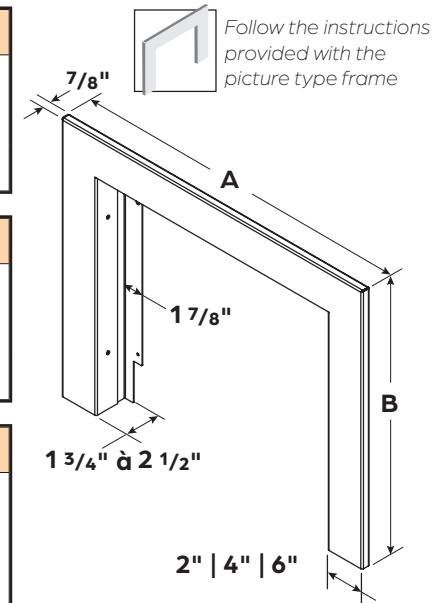

# 3

## DIMENSIONS

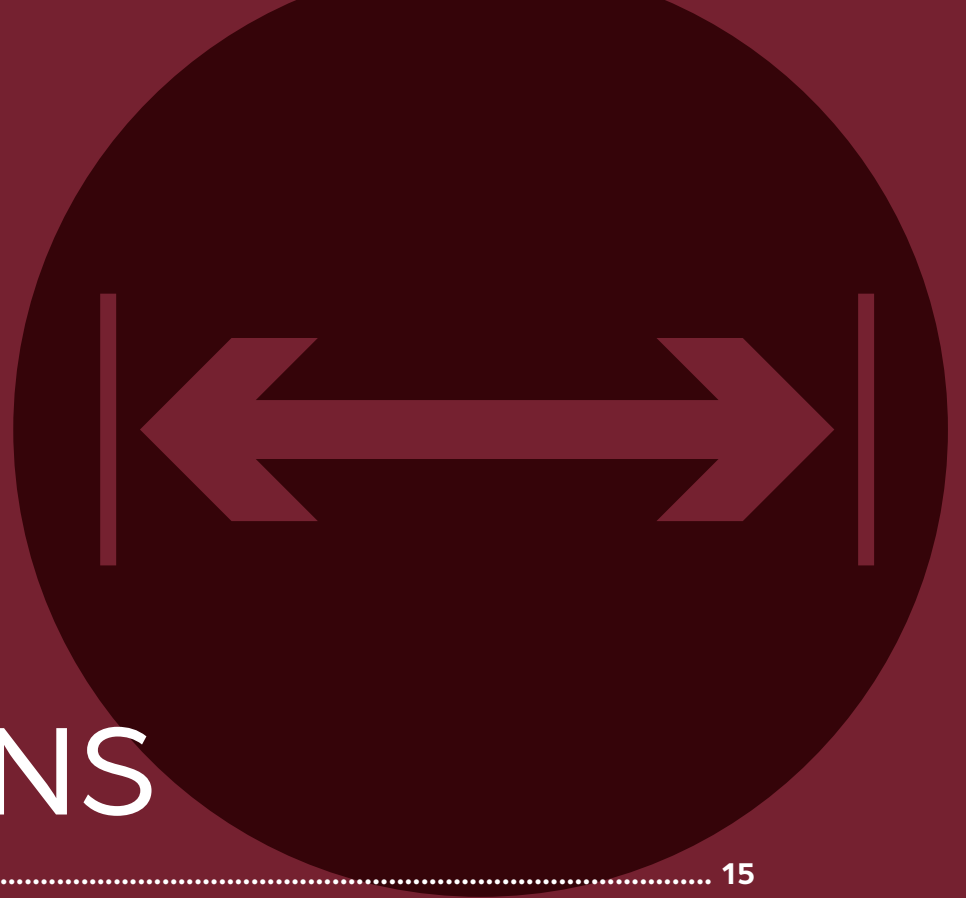

3.1	STÛV 16-Z DIMENSIONS .....	15
3.2	FRAMEWORK CHARACTERISTICS .....	16
3.3	HEARTH OPENING .....	16
3.4	FLOOR PROTECTION AND R VALUE .....	17
3.5	CLEARANCE .....	18
3.6	RISK AREA .....	19
3.7	BASE IN COMBUSTIBLE MATERIALS .....	19
3.8	INSTALLATION A 16-Z WITH AN H BASE .....	20
3.9	FITTED TELEVISION .....	21
3.10	SHELF MADE OF COMBUSTIBLE MATERIALS .....	21
3.11	AIR SUPPLY .....	22

# 3.1 STŮV 16-Z DIMENSIONS



FRONT VIEW

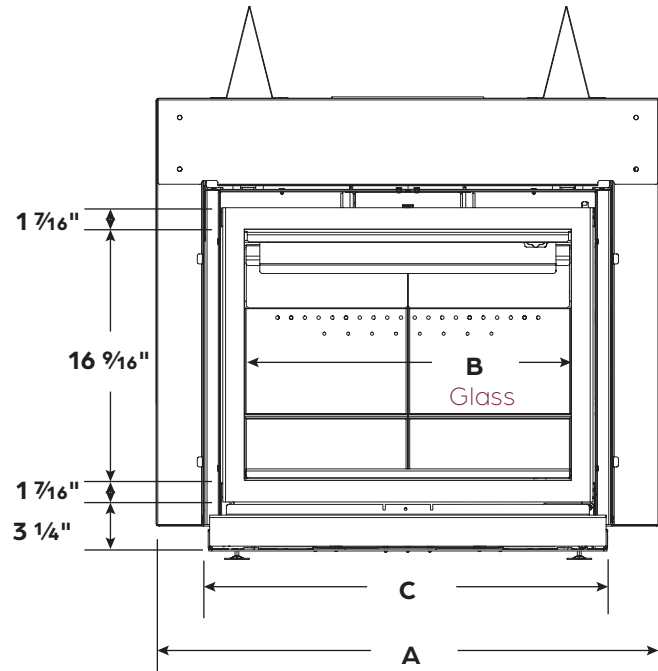

SIDE VIEW

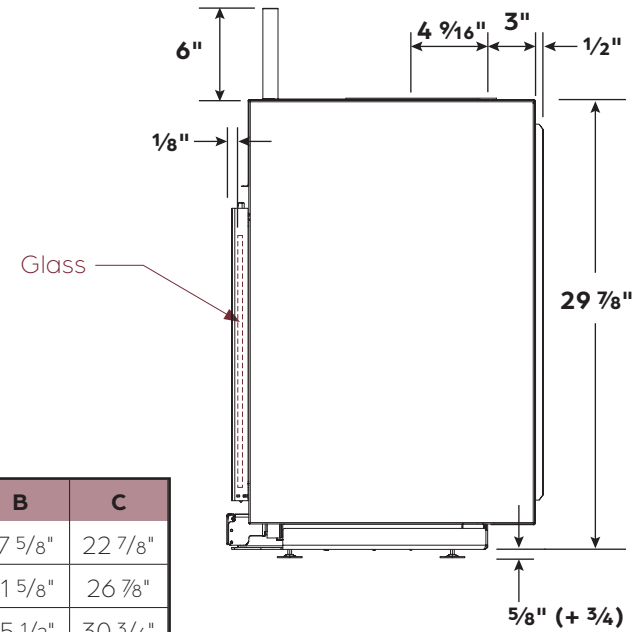

16-Z	A	B	C
16-58 Z	29 3/8"	17 5/8"	22 7/8"
16-68 Z	33 5/16"	21 5/8"	26 7/8"
16-78 Z	37 1/4"	25 1/2"	30 3/4"

BOTTOM VIEW

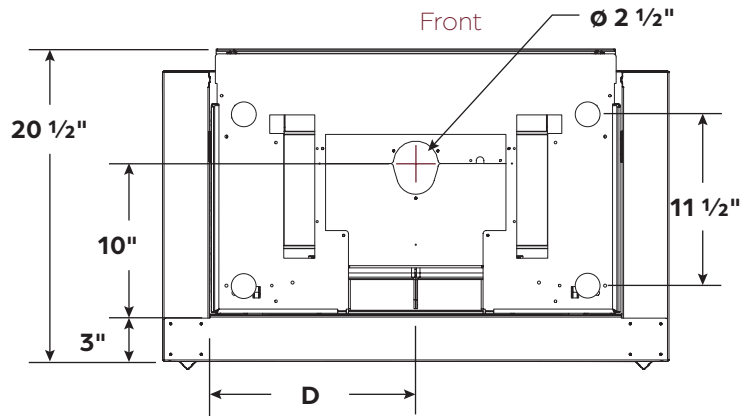

TOP VIEW

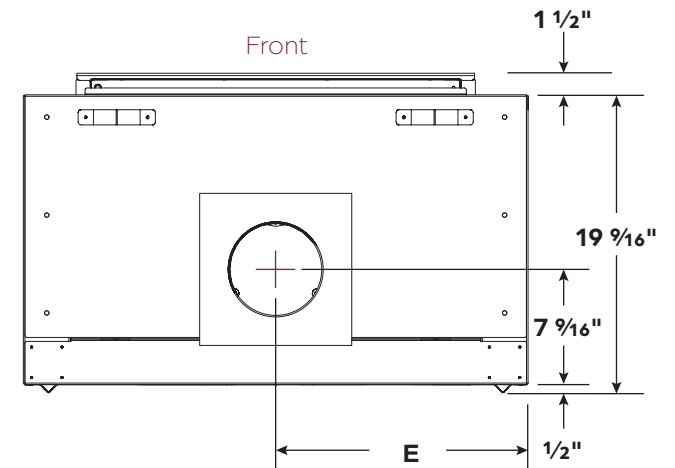

16-Z	D	E
16-58 Z	11 7/16"	14 7/8"
16-68 Z	13 3/8"	16 9/16"
16-78 Z	15 3/8"	18 9/16"

### 3.2 FRAMEWORK CHARACTERISTICS

### 3.3 HEARTH OPENING



#### NOTE

Framing is not always perfectly level. We suggest that at least **1/4" clearance** be added to the dimensions listed in the table.

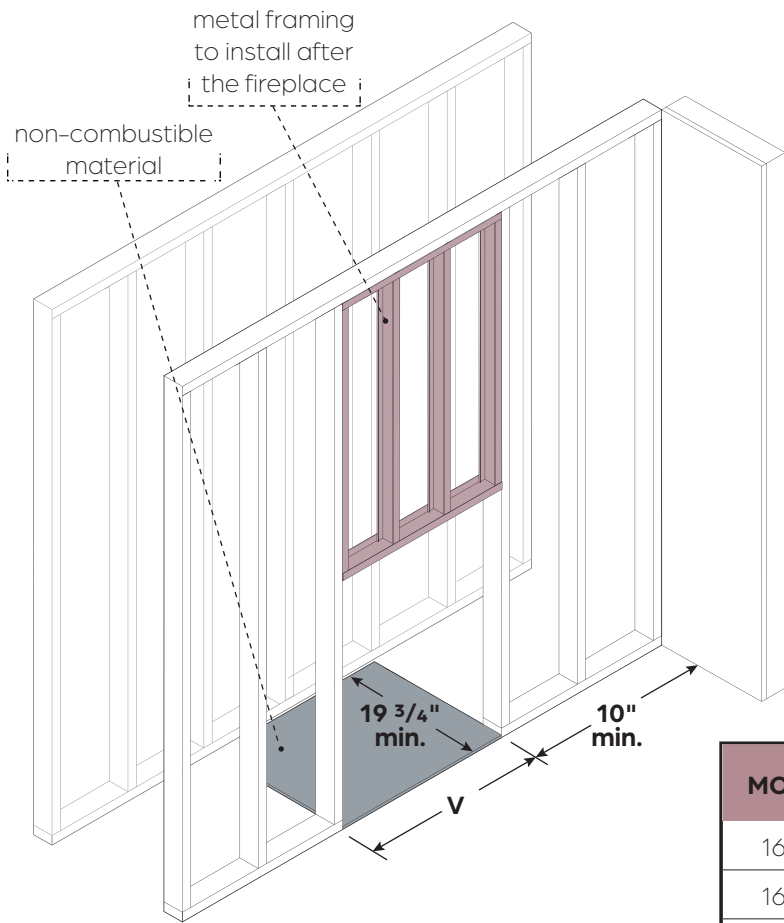

MODEL	V	W
16-58	29 5/8"	22 7/8"
16-68	33 9/16"	26 7/8"
16-78	37 1/2"	30 3/4"



Stand-off zone  
**mandatory non-combustible**



combustible



non-combustible  
**mandatory**

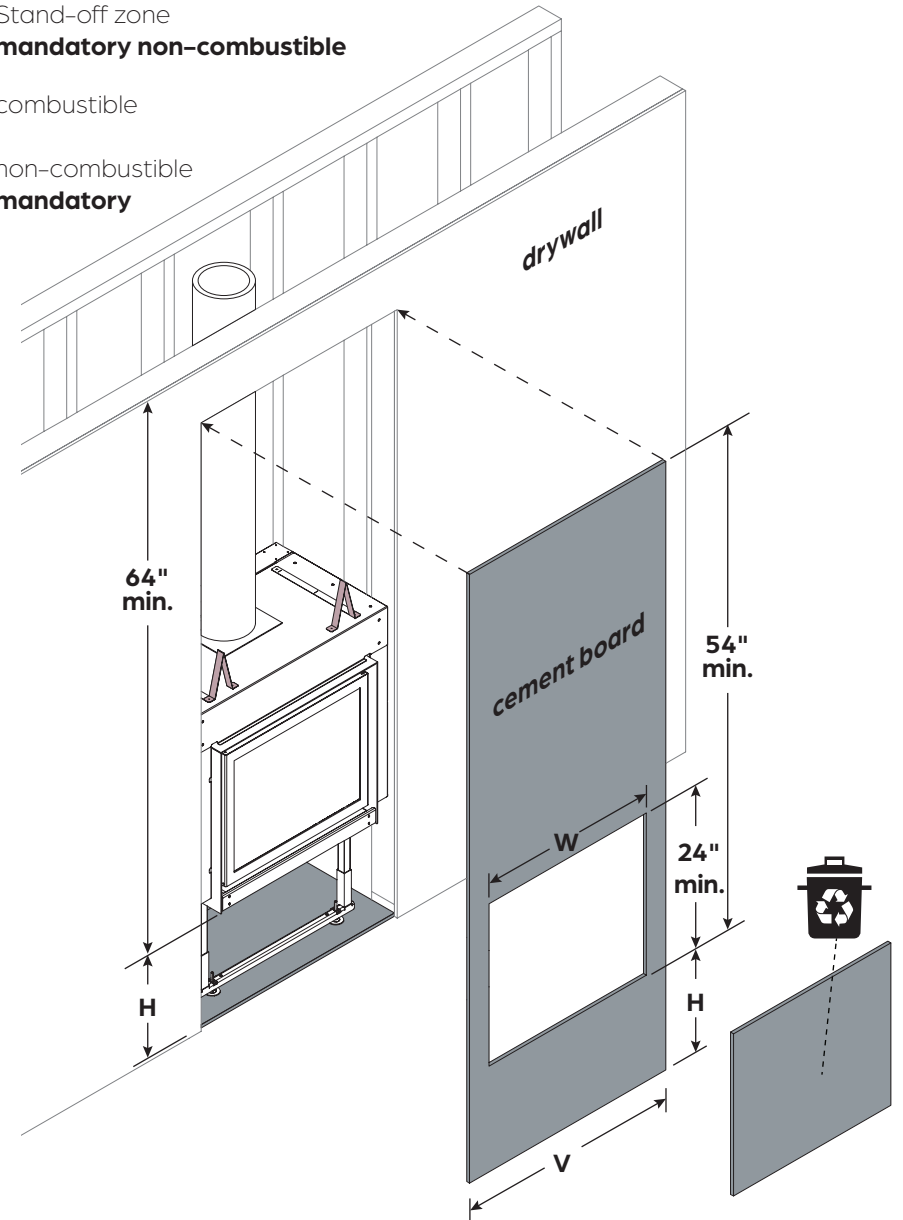

### 3.4 FLOOR PROTECTION AND R VALUE



- non-combustible mandatory
- R value zone See table

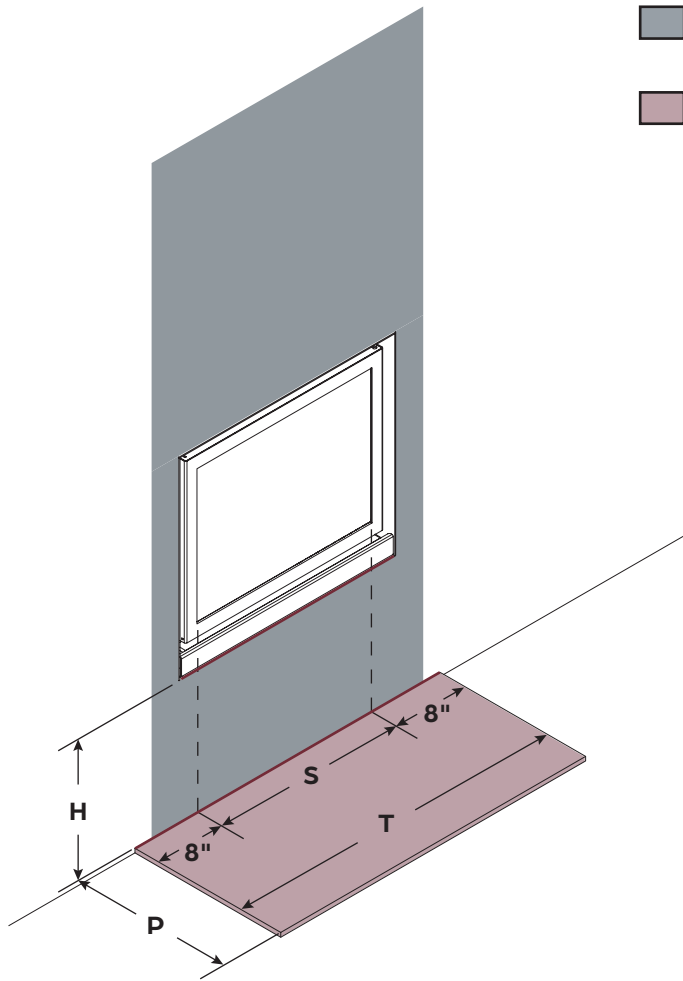

MODEL	P	S	T
16-58		17 5/8"	33 5/8"
16-68	Canada: 18" USA: 16"	21 5/8"	37 5/8"
16-78		25 1/2"	41 1/2"

To be compliant with the building code, floor protection is mandatory. The floor area in front of the appliance must be protected by a **non-combustible material**.

Your Stûv unit's distance from the floor is also important to determine the non-combustible material to use for the floor protection. It should have an R value equivalent to or higher than that indicated in the table below.

**Example:** If the fireplace is 9" off the floor, the floor protection's R value must be at least 0.28.

H	R VALUE	EXAMPLES
11 1/2" +	0	All non-combustible materials
8 1/2" to/à 11 1/2"	0.28	1/2" cement board (0.26) + 1/4" ceramic (0.02) = 0.28 R
6 1/2" to/à 8 1/2"	1.29	1/2" Micore® SB (1.47) + 1/4" ceramic (0.02) = 1.49 R
4 1/2" to/à 6 1/2"	2.56	1" Micore® SB (2.94) + 1/4" ceramic (0.02) = 2.96 R

This protection must extend the entire width of the glass, plus 8" on each side, on the projection (**P** in the table) according to the standards applicable in the country concerned. The projection is calculated starting from the front of the door.

If two non-combustible materials need to be joined on a section of the floor protection, a non-combustible gasketing strip must be affixed the entire width of the junction to keep embers from reaching the subfloor.

The red line on the illustration shows where to place the gasketing strip.

In addition to the floor strip, a non-combustible gasketing strip must be affixed between the base plate and the wall finishing to keep embers from entering the wall.

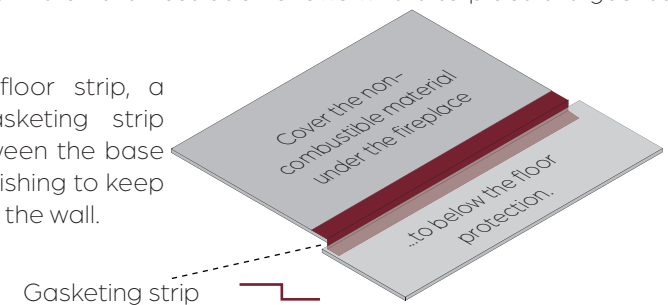



# 3.5 CLEARANCE



TOP VIEW

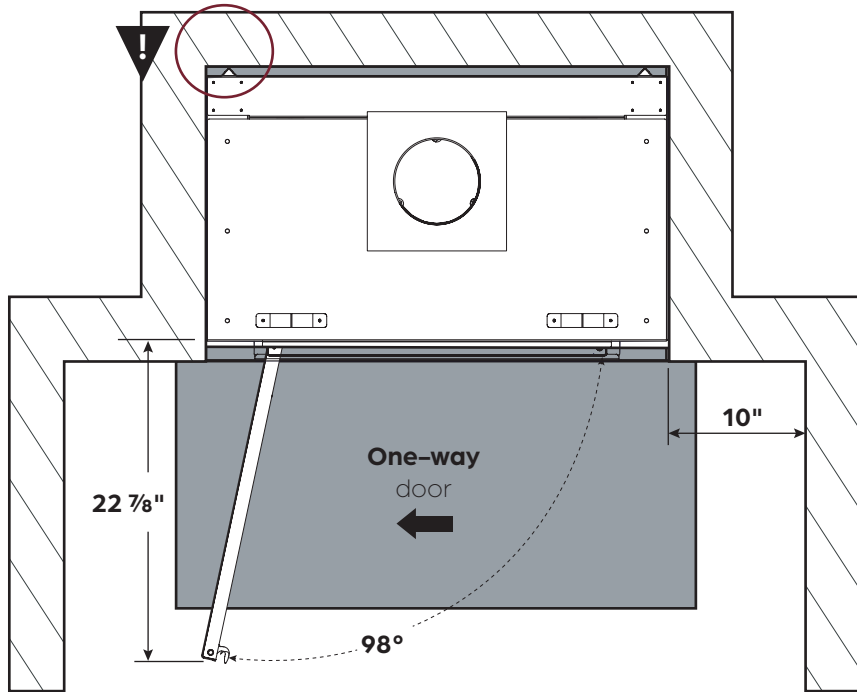

TOP VIEW - CORNER

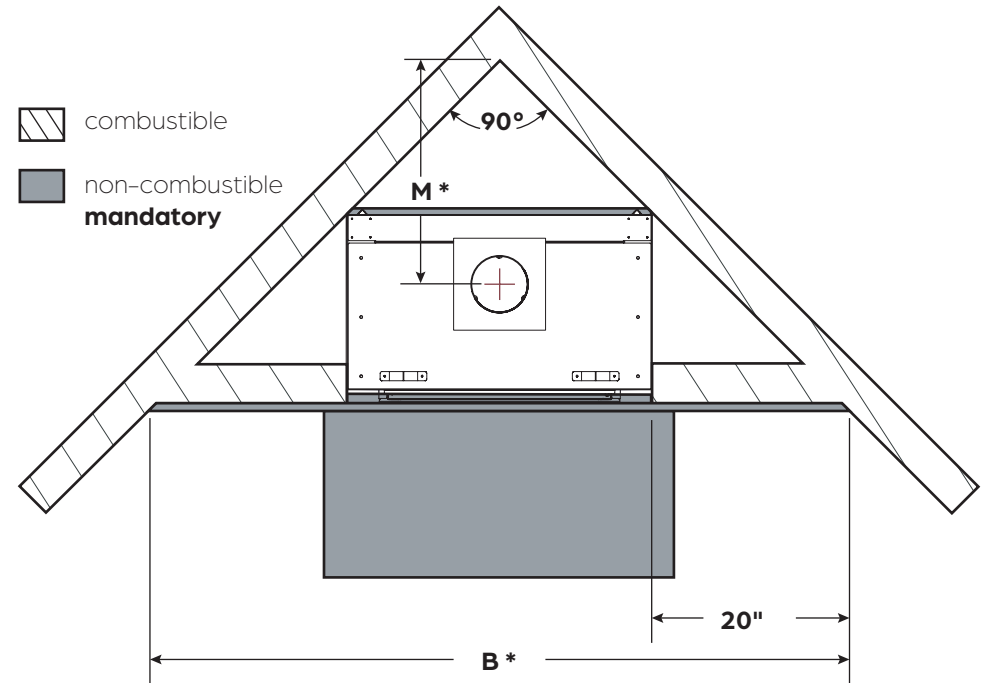

## CAUTION - AERATED SPACE

The spacers at the back of the insulated shell indicate an area that needs to be aerated. Do not fill the aerated spaces with insulation or any other material, whether combustible or not.

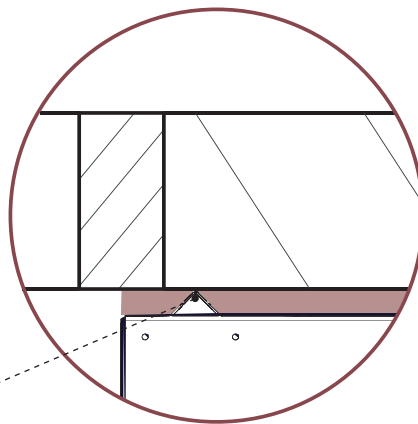

Aerated space

1/2" spacer

MODEL	M *	B *
16-58	22 1/2"	69"
16-68	24 1/2"	72 7/8"
16-78	26 1/2"	76 3/4"

\*This is an example of an installation in a 90° wall corner. This measurement may vary depending on the location of the installation. No matter the angle of the wall, the minimum clearances indicated on this page must be respected.

### 3.6 RISK AREA

The heat radiating from the glass will be significant. Any combustible object must be placed a minimum of 48" by 90° away from the glass face to avoid all risk of fire.

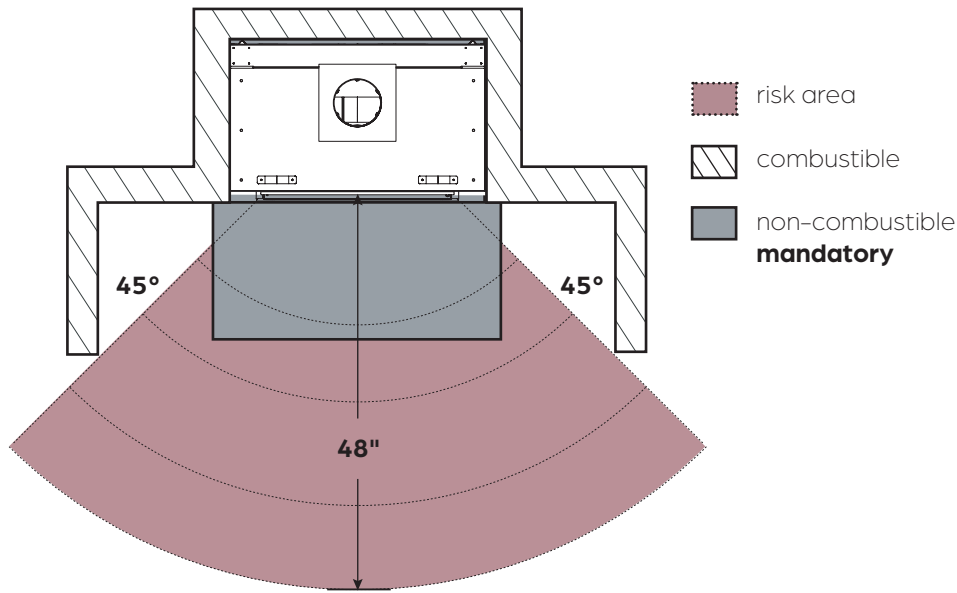
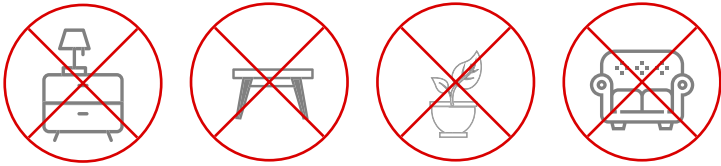

### 3.7 BASE MADE OF A COMBUSTIBLE MATERIAL



A structure can be built to position the fireplace at the right height. It can be made of a combustible material like framing timber, but **it is mandatory to add a non-combustible material**, like cement board, to the combustible base to avoid the risk of fire.

For the height (**H**) of the base, use the unit's dimensions to adjust.

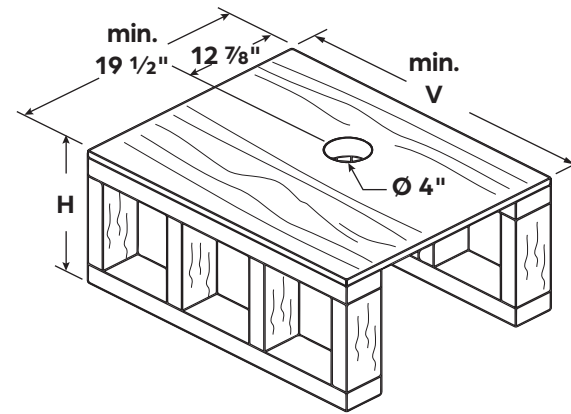

MODEL	V
16-58	29 3/8"
16-68	33 5/16"
16-78	37 1/4"

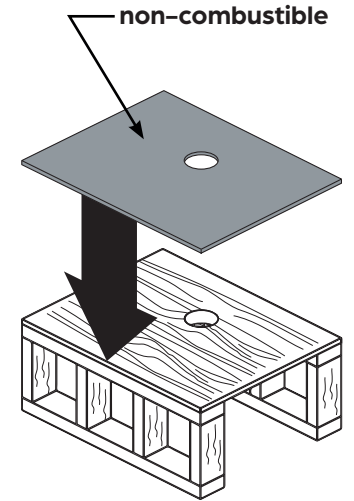

#### ! CAUTION - FIRE HAZARD

To prevent a serious incident, no combustible material should be placed near the door or near the hot air outlet. Blocking the latter may cause the unit to overheat and, in some cases, cause a fire.

**Avoid heat traps.** Materials exposed to the radiant heat must be able to withstand high temperatures.

#### ! STRUCTURE'S LOAD-BEARING CAPACITY

It is vital to ensure that the combustible structure and the floor are strong enough to hold the weight of the fireplace and the weight of the chimney. See the technical specifications (page 6) for the weight of the units.

If in doubt, **consult a specialist.**

# 3.8 INSTALLING A 16-Z WITH AN H BASE



**NOTE**  
These obligations must be respected **in addition to** the minimum clearances indicated on the previous pages.



- additional**  
non-combustible
- mandatory**  
non-combustible

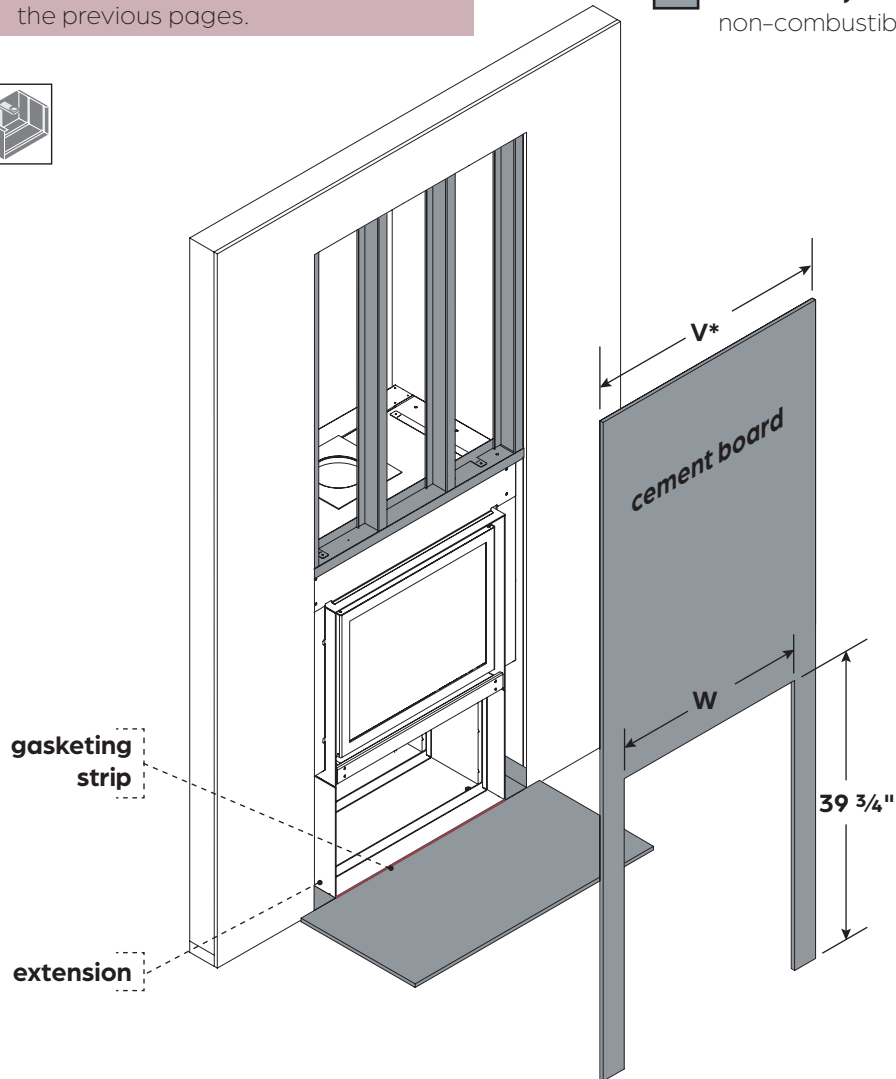

gasketing strip

extension

## PROTECTION OF THE COMBUSTIBLE MATERIALS

All components added between the H base and the external dimensions of the insulated shell (**V**) must be made of **non-combustible materials**.

It is mandatory to extend the non-combustible floor protection under the H base. It is also mandatory to protect the wall structure by adding non-combustible materials vertically on the sides and in the back.

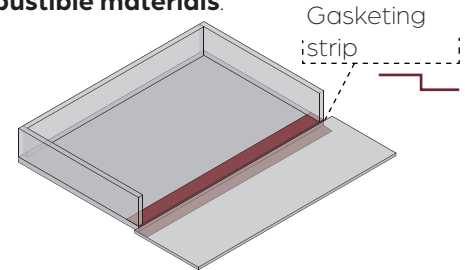

The junction between the non-combustible material under the H base and the non-combustible floor protection in front of the fireplace must be airtight to keep embers from getting inside the wall or under the subfloor.

— The red line on the illustration shows where to place the gasketing strip.

## AFFIXING THE WALL FINISHING

The **V\*** dimension indicates the minimum measurement to cover the insulated shell.

To make it easier to affix the wall finishing, we recommend cutting the cement board wider to reach the wall structure's wood frame. This will help make the two sides around the H base more rigid.

The wood frame will therefore be used to affix both the drywall and the cement board. If a structure is added around the H base to affix the cement board, it must be made of a non-combustible material.

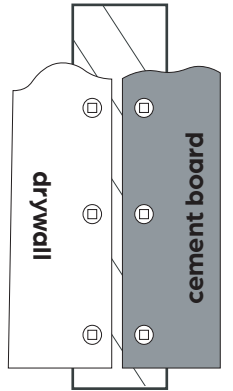

MODEL	V	W
16-58	29 3/8"	22 7/8"
16-68	33 5/16"	26 7/8"
16-78	37 1/4"	30 3/4"

- combustible (drywall)
- combustible
- non-combustible (cement board)

### 3.9 FITTED TELEVISION

It is possible to install/build in a TV above the unit. That said, to ensure adequate ventilation, it is important that the recess created for this purpose have a **maximum depth of 4"** and to have a **clearance of a minimum of 4"** between the television and other objects (walls, frames, etc.). Failing to do so may cause the television's internal temperature to rise and may result in a fire and/or damage to the product. There must be a minimum of **2"** between the back wall and the appliance's chimney at all times.

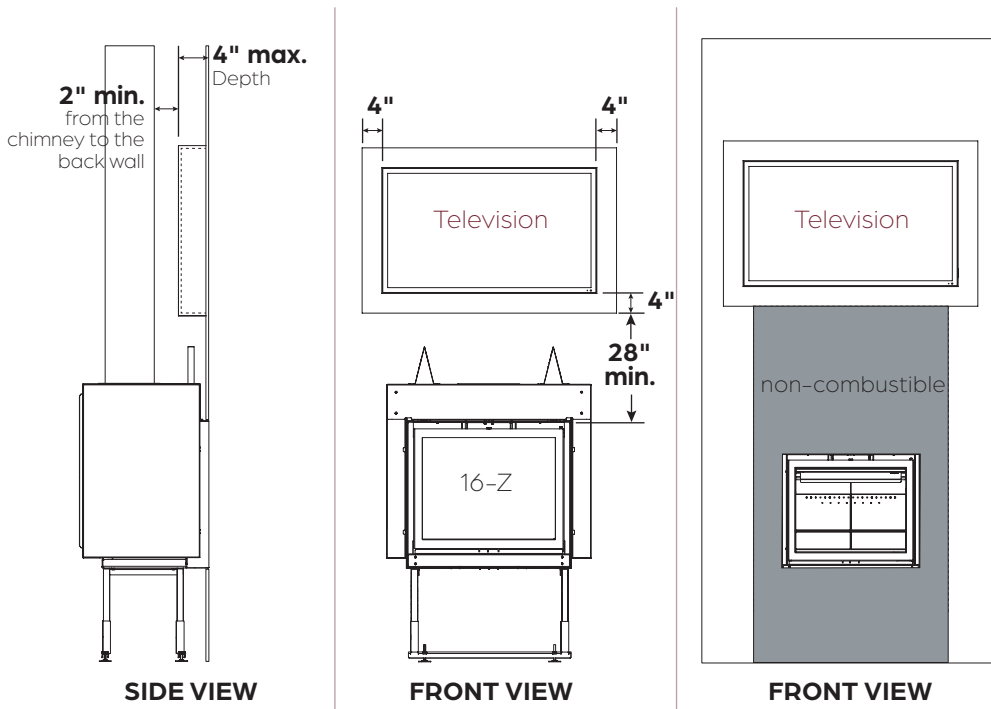

### 3.10 SHELF MADE OF COMBUSTIBLE MATERIAL



It is possible to install a shelf or decorative object made of a combustible material **starting at 28"** from the top of the unit's opening.

For a shelf made of a combustible material, it is important to take the depth of the shelf into account, as it can greatly influence the shelf's positioning in relation to the top of the fireplace opening (glass frame).

Use the table or the formulas below to find the measurements for installation as desired.

**H =** Height under the shelf from the top of the fireplace's opening

**P =** Maximum depth of shelf from finished wall

For a specific height:

$$P = H - 22"$$

For a specific depth:

$$H = P + 22"$$

combustible =  non-combustible =

H \ P	1 à 6"	7"	8"	9"	10"	11"	12"
27"							
28"							
29"							
30"							
31"							
32"							
33"							
34"							

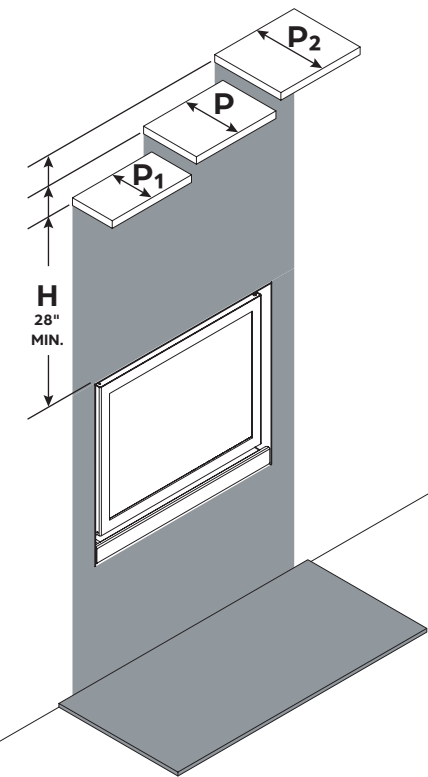

**! WARNING**  
For more information about installation above a fireplace, refer to your television's installation/operating manual or contact the television manufacturer and follow the instructions.

**! ATTENTION** This configuration is at the user's discretion. Stûv America does not recommend this installation and disclaims all liability.



The fireplace is supplied by two types of air:

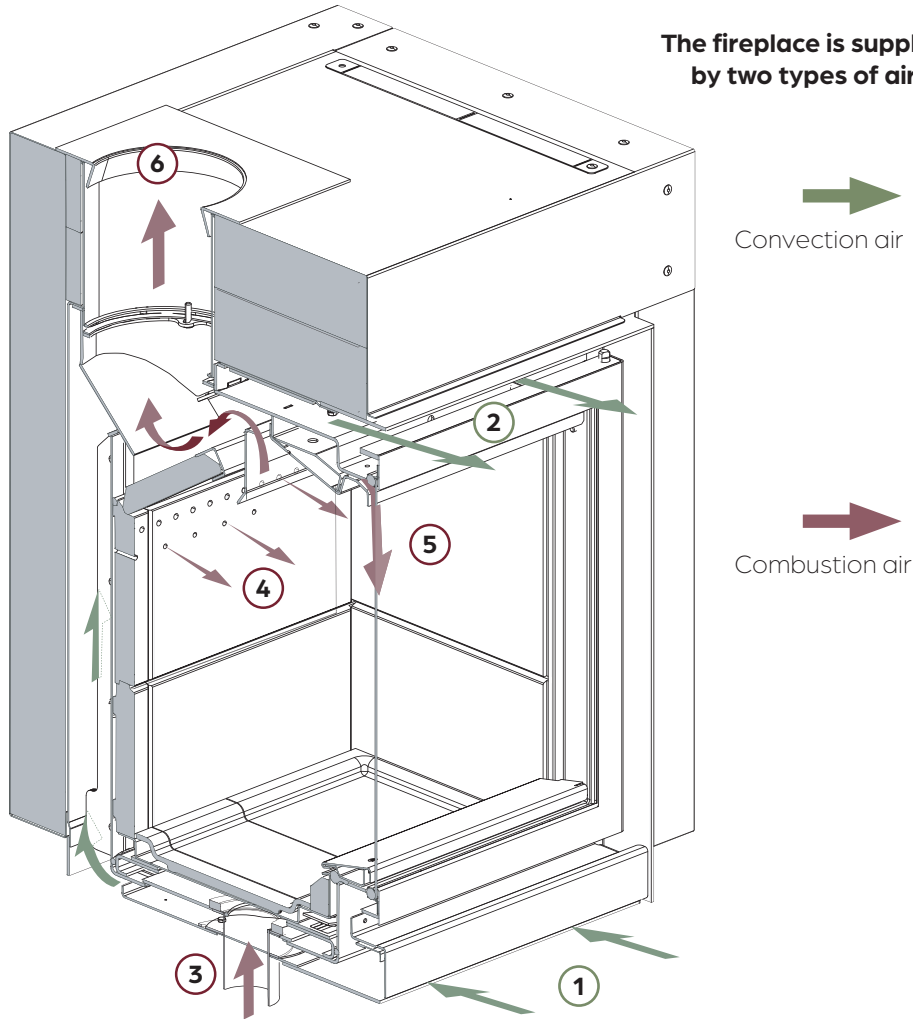

## CONVECTION AIR

The convection air system is incorporated in the fireplace. No connection is needed for its operation.

- 1 The ambient air gathered from the room moves along the combustion chamber, absorbing heat
- 2 Once heated, this air exits naturally through the appliance's upper frame, spreading a comforting warmth throughout the room.

## COMBUSTION AIR

- 3 The air required for combustion arrives directly from under the appliance via an outside air intake connector specially designed for the Stûv 16-Z model of the H base (see next page for details).
- 4 The air injected into the top of the combustion chamber allows the gases to be burned a second time, preventing fine particles from being released into the air.
- 5 The air flow along the glass helps keep it free of combustion dust, for an impeccable view of the fire.
- 6 Once the gases have been burned, they are evacuated through the chimney pipe (see CHIMNEY section for details).

The air combustion inlet can be configured in **three ways**. See next page for details.

### ! CAUTION

The air intake must never be adjusted. This wood heater has a manufacturer-set minimum low burn rate that must not be altered. It is against federal regulations to alter this setting or otherwise operate this wood heater in a manner inconsistent with operating instructions in this manual.

### ! NOTE

Active air extraction systems (range hood, air conditioning, controlled mechanical ventilation, another fireplace, etc.) in the same space or in an adjacent room also consume a large amount of air, which could create negative pressure in the room and hamper the fireplace's operation (risk of backdraft). They can disrupt the fireplace's operation even if connected to an outside air intake.



## COMBUSTION AIR (OPTIONS)

### Option 1: Connected to the outside air with a kit

Although **recommended**, this setup is mandatory in some places. Whether it is connected to the fireplace or not, the duct leading to the outside air must:

- be protected outdoors by a grille whose clear passage section is at least 4" in diameter. Beware of water infiltration, snow accumulation and wind impacts, which can damage the system or hinder its operation
- not be crushed
- ideally be equipped with an air damper (optional)
- be at least 8' long, ideally insulated, and form a loop in the wall to prevent condensation **(in places with winter temperatures)**.

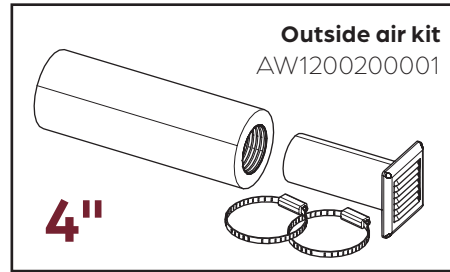

If our standard  $\varnothing$  4" flexible duct is used, we recommend a maximum length of 12' with no more than 4 bends (see table to the right). If these recommendations are exceeded, it will be necessary to compensate with a larger diameter and/or a smoother duct.

Duct length	Max. number of 90° bends authorized
0 to 8'	4 bends
8' to 10'	2 bends
12' and +	1 bend

### Option 2: Connected to the inside air, in another location near the fireplace.

This air inlet must have a sufficient air intake (minimum  $\varnothing$  4"), from a crawl space, ventilated room (basement) or another room in which the air exchange will always be sufficient.

The criteria for the length of the duct and the bends are the same as for the option 1.

### Option 3: Without a connector, air taken from the same room as the fireplace

This option is not recommended for an airtight house. If it is not possible to connect the fireplace to the outside air, it is important to ensure that the air exchange in the room will always be sufficient when the fireplace is in operation.

## AIR DAMPER (OPTIONAL)

The air damper keeps the house from cooling down when the fireplace is not in use. It has a 100% open and a 100% closed position, which cannot affect combustion. It is recommended when installing in a highly energy-efficient house.

It should ideally be placed as close to the outer wall as possible. Validate that the air damper dimensions meet the installation's needs. The damper's control cable is 48" long and the damper is  $\varnothing$  4" in diameter.

## CONNECTORS

**Air intake connector 16-Z version**  
AW1200200500

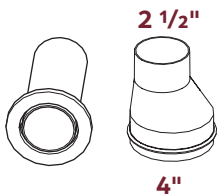

**Air intake connector with a 90° bend 16-Z version**  
AW1200202900

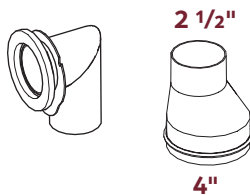

**Air intake connector H base version**  
AW1200200700

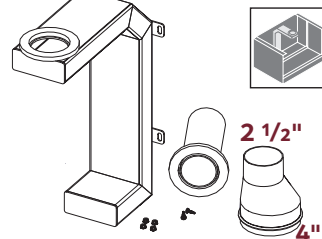

For more information, see the **Air Damper Installation Manual** (9310400019).

**Air damper**  
AW1200100300

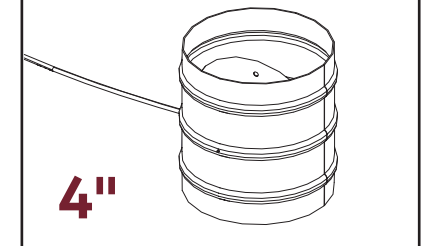

# 4

## INSTALLATION



4.1	UNPACKING .....	25
4.2	OPTION: ADJUSTABLE STAND.....	27
4.3	BASE PLATE AND CONNECTION .....	29
4.4	FINISHING .....	36
4.5	ADJUSTING THE DOOR .....	37
4.6	RECAP .....	39



**! IMPORTANT**  
The paint is not cured. It is therefore fairly **fragile**, but will harden after being heated a few times. Handle the unit with care.

**Step 1** Remove and validate the other accessory boxes.

**Step 2** Using a crowbar, remove the top of the pallet. Remove each side so that only the base is left. Cut the straps and carefully remove the protective plastic using a retractable knife. Cut **at the back of the unit** so as not to damage the paint.

**Step 3** Take out the base plate and set it aside for later. Remove the styrofoam and recycle the entire packaging.

**! Inspect the unit.**  
The warranty does not cover shipping-related damage unless it is reported within 48 hours of delivery.

Follow these steps to remove the fireplace's door.

**Step 4** Place the door handle around the lock cylinder above the door.

**Step 5** Turn the door handle counter-clockwise to open the door.

**Step 6** Open the door 90°.

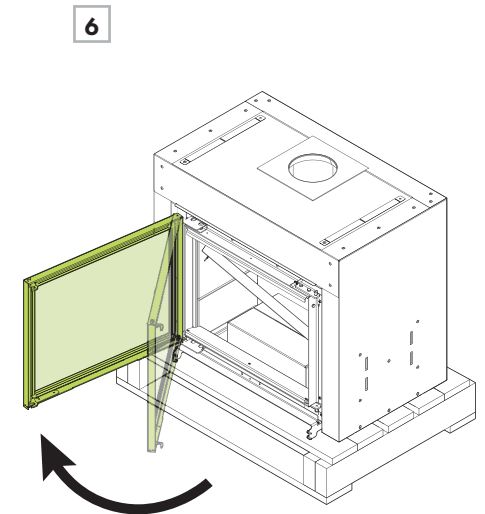
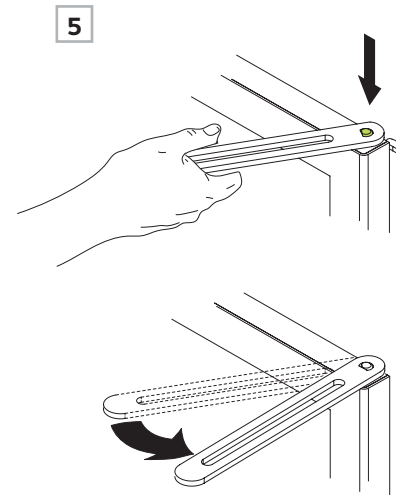
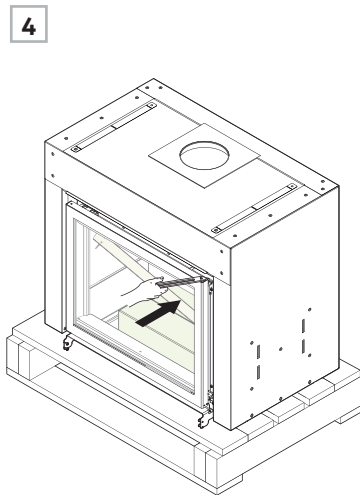
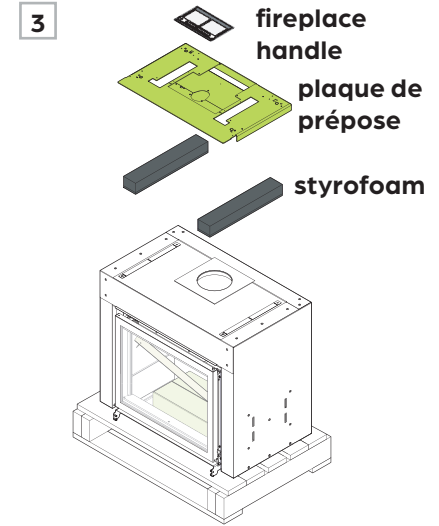
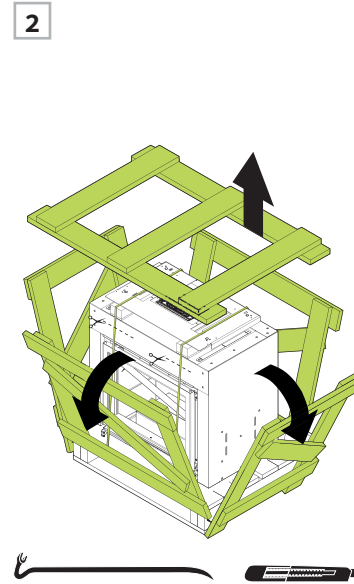
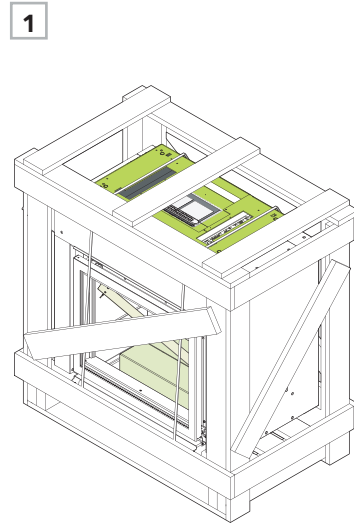



## 4.1 UNPACKING



**Step 7** Locate the spring at the bottom of the door, near the rotation axis.

**Step 8** Disengage the spring by pushing it down and pulling it forward.

**Step 9** Slowly and gently lift the door to take it off its hinges.

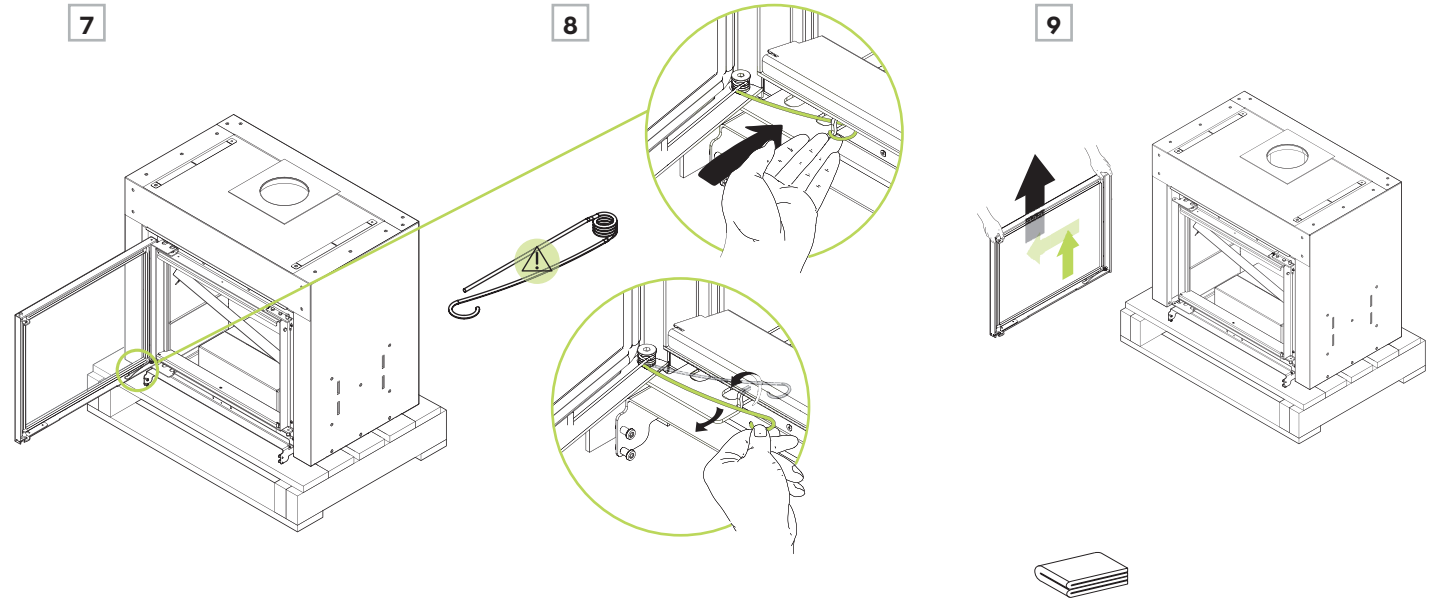

**Step 10** Take the box out of the combustion chamber and validate the receipt of all the accessories.

### 10 CONTENT OF THE BOX

1. **4x** white glove
2. Installation manual
3. Spray paint for touch-ups
4. Stûv glove
5. **4x** 16-Z leveling feet
6. **3x** hex head screw (M6 x 18 mm)
7. **4x** headless screw (M10 x 20 mm)

#### For all Stûv 16 models

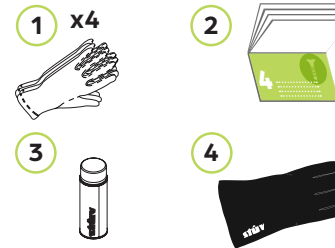

#### Specific to Stûv 16-Z

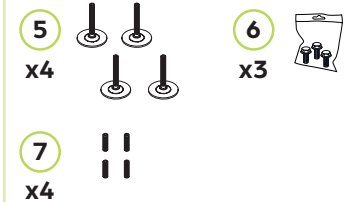

### CHECK

Check if all the material is included and in good condition.

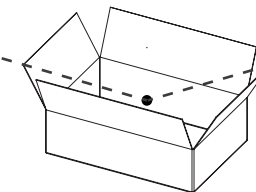

## 4.2 OPTION: ADJUSTABLE STAND



### NOTE

Follow these instructions to install the **adjustable stand**. This stand is strongly recommended to ease the connection to combustion air supply arriving from under the fireplace or simply to raise the unit.

To calculate the height of the adjustable stand, you will need to know the thickness of all the floor components in front of and under the fireplace. Use the formula below and the illustration to determine the **cut-off** length.

The adjustable stand is installed under the base plate. Its total height will therefore raise the fireplace by that height. To determine the cut-off according to the measurement from the bottom of the glass, subtract the height of the glass (see box).

Fill in the formula below to calculate how much to cut off the adjustable stand:

$$\begin{array}{ccccccc}
 \boxed{25''} & + & \boxed{\text{_____}} & - & \boxed{\text{_____}} & - & \boxed{\text{_____}} & = & \boxed{\text{_____}} \\
 \text{Height of} & & \text{Thickness of floor} & & \text{Thickness of} & & \text{Height under} & & \text{Cut-off} \\
 \text{the stand} & & \text{under fireplace} & & \text{finished floor} & & \text{fireplace} & & \\
 \end{array}$$

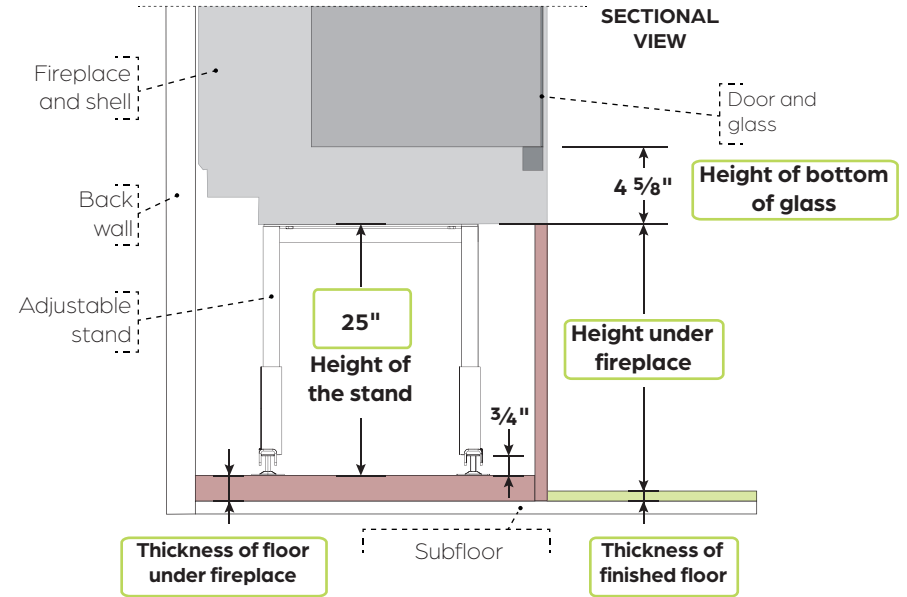

### OPTION: ADJUSTABLE STAND

Follow these steps after calculating the cut-off.

**Step 11** Install the non-combustible material where the fireplace will go. See the **DIMENSIONS** section (pages 16 & 17).

**Step 12** Screw or unscrew the feet to obtain a distance of  $\frac{3}{4}''$  between the bottom of the feet and the bottom of the adjustable stand. This will make it possible to adjust both sides during levelling.

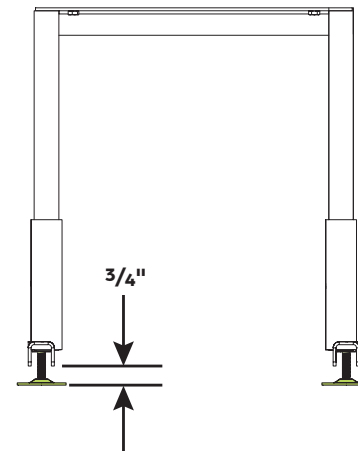
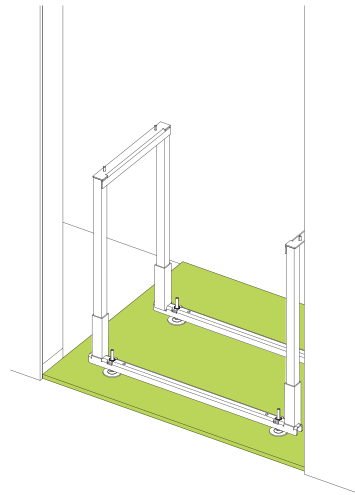

## 4.2 OPTION: ADJUSTABLE STAND



**Step 13** The adjustable stand can be cut by removing the rods from the base.

**Step 14** Cut the 4 rods the same height using a disc cutter and a vice to hold the stand.

**Step 15** Position the stand vertically and then put the rods back in.

13

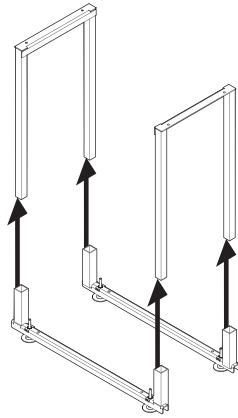

14

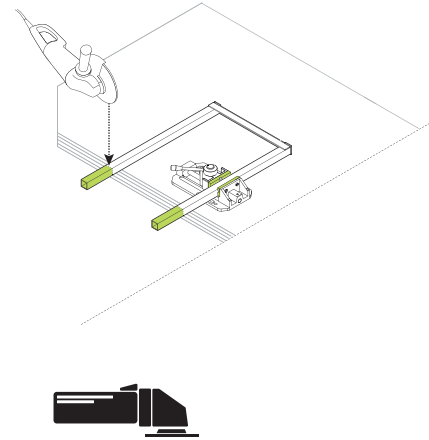

15

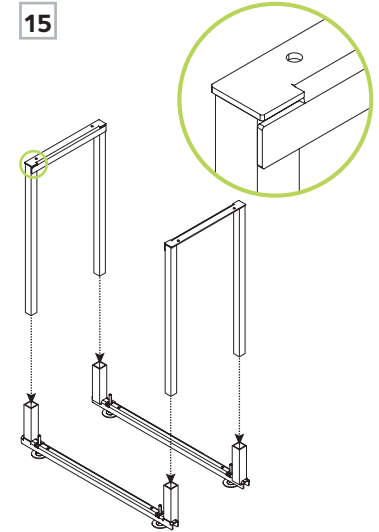

**Step 16** Place the base plate on the adjustable stand.

**Step 17** Screw in the base plate from underneath, using the hex head screws.

**Step 18** Follow the steps on the next page to position and level the base plate with the stand attached.

16

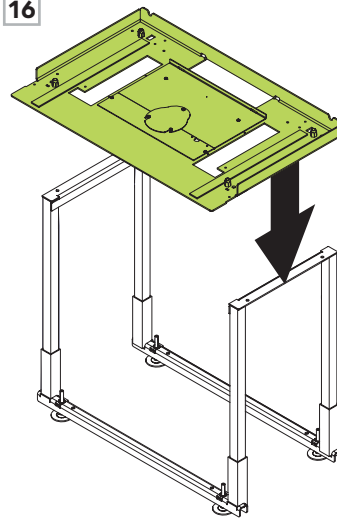

17

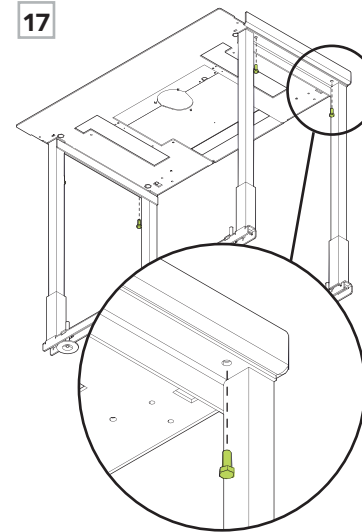

18

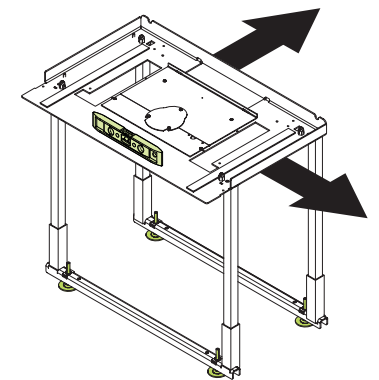

## 4.3 BASE PLATE AND CONNECTION



### NOTE

Structures are not always perfectly level. We suggest allowing **at least 1/4" of clearance..**

See the **DIMENSIONS** section to prepare the installation site.

**Step 19** Install the frame without the metal structure above the fireplace.

**Step 20** Install the non-combustible material under the fireplace.

**Step 21** If needed, make the base out of combustible materials, then cover with non-combustible materials.

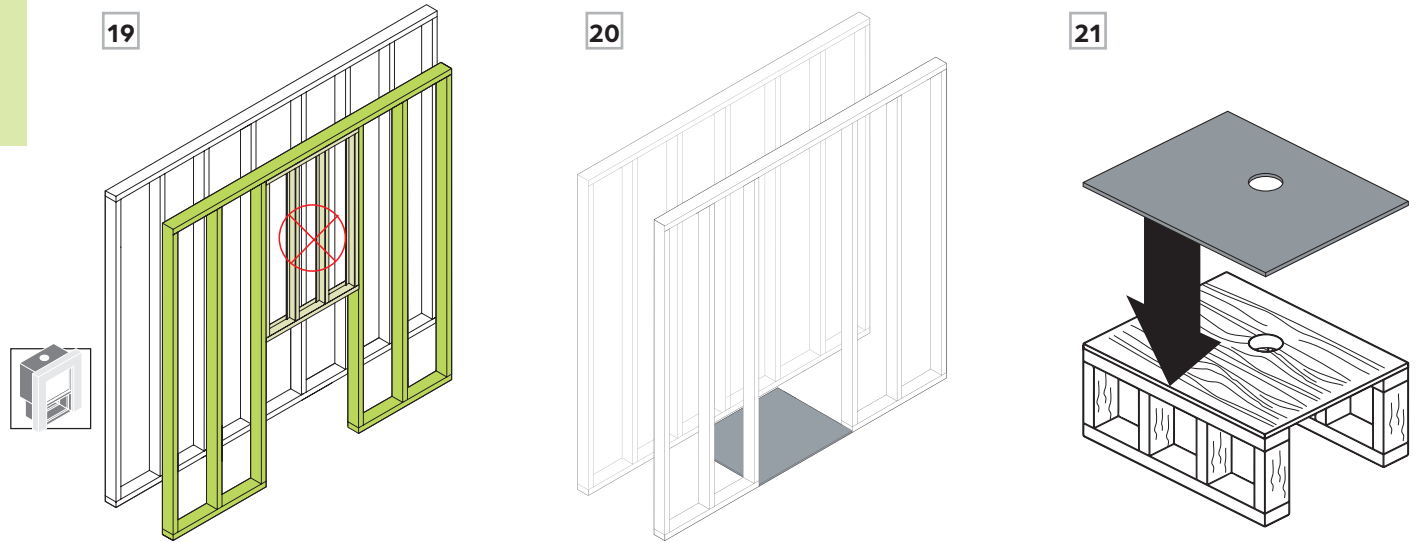

Prepare the base plate for the combustion air intake according to the chosen configuration:

**Step 22** If using a 16-Z connector, only remove the cutout in the middle of the trap and connect with a clamping collar.

OR

**Step 23** For the H base connector, remove the traps and the trap cutout.

If the fireplace is installed without a connector, the base plate must stay as is.

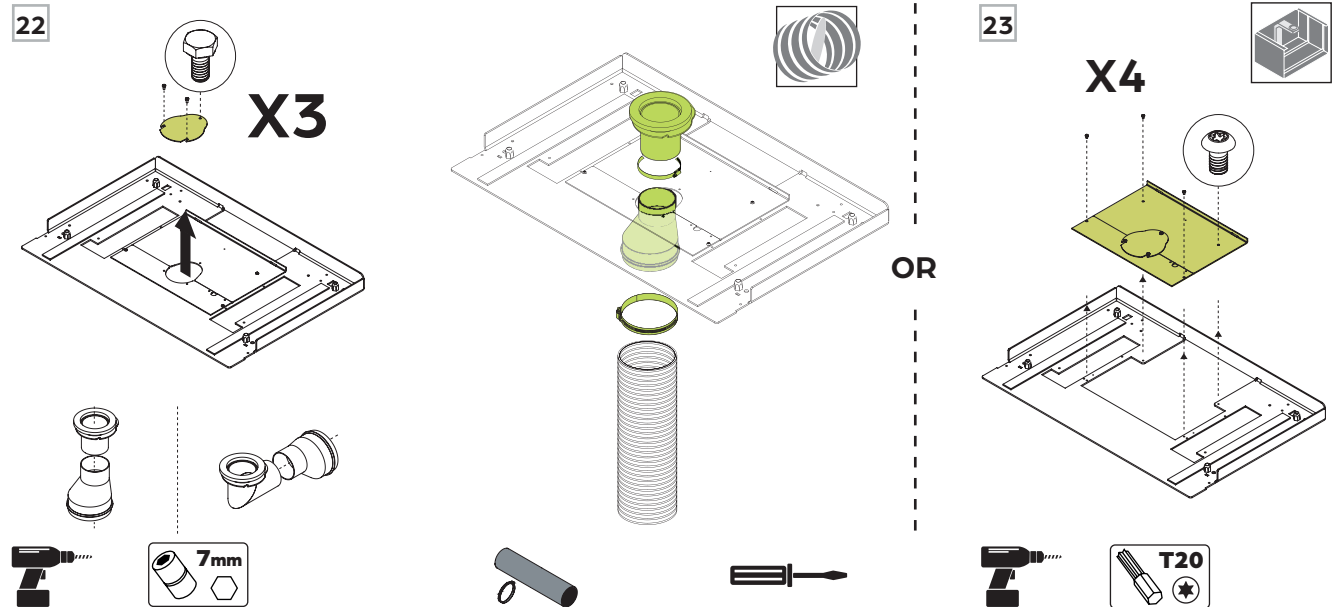

## 4.3 BASE PLATE AND CONNECTION



**Step 24** If the fireplace is installed without the adjustable stand or without the H base, screw the levelling feet **or** the headless screws at mid height under the base plate. The feet will make it possible to level the plate.

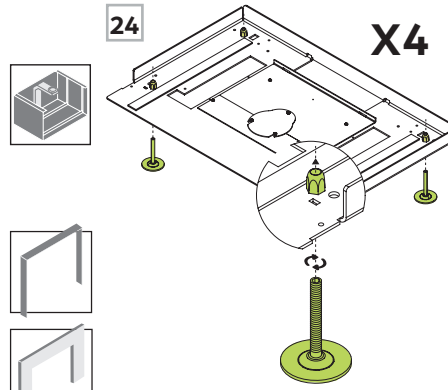

**Step 25** Position the base plate in the previously built frame using the measurements in the illustration. **See the frame installation manuals** to calculate the exact depth according to the chosen frame.

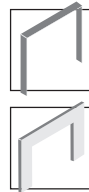

Validate the clearances and mandatory non-combustible materials.

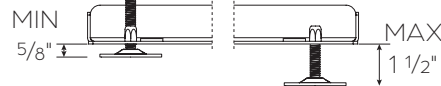

25



### NOTE

Structures are not always perfectly level. We suggest allowing **at least 1/4" of clearance**.

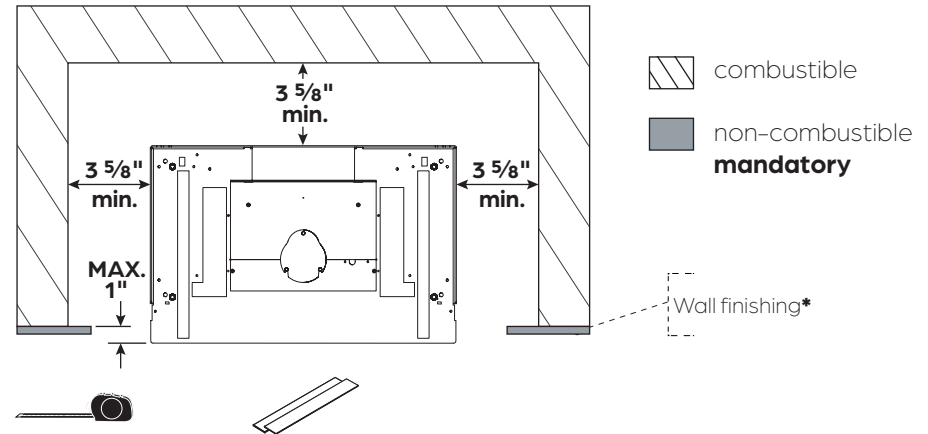

### Things to take into consideration:

- The thickness of the **wall finishing** can affect the fireplace's depth. Refer to the installation manual for the chosen frame.
- The **air intake** duct is connected via the bolted-on cutout. Place the plate to facilitate its connection.
- The small hole cut out of the back trap indicates the middle of the **smoke outlet**. Use a laser pointer to align it with the chimney.
- The front edge of the base plate will be **set back 5/16" from the flap** and the front of the thin edge frame.

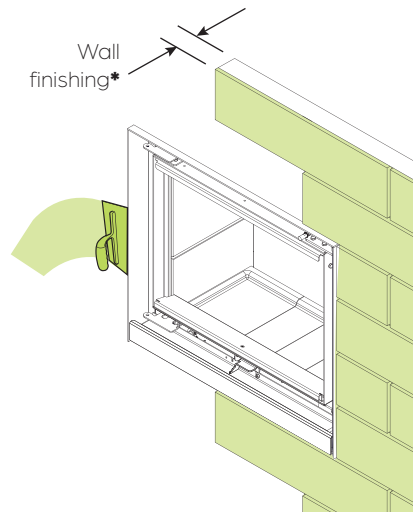

### AIR INTAKE

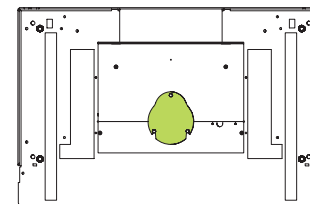

### SMOKE OUTLET

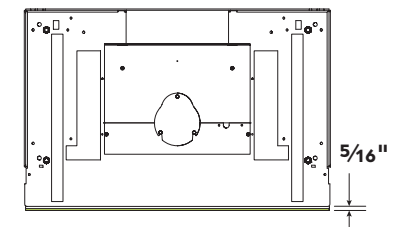
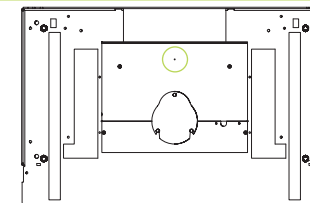

Setback from the flap

## 4.3 BASE PLATE AND CONNECTION



**Step 26** Level the leveling feet, on the base plate, on the adjustable stand or on the H base.

**Step 27** When the fireplace is in its final location, screw on the adjustable stand or the base plate using self-drilling screws (not included) to affix the fireplace.

36

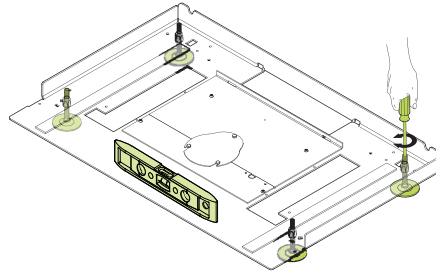

27

NOT INCLUDED

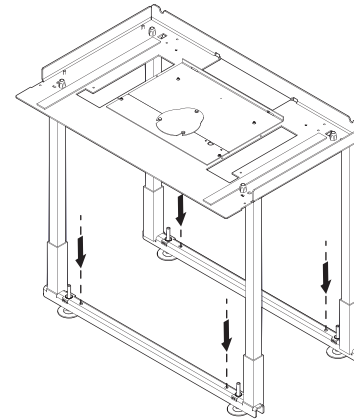

NOT INCLUDED

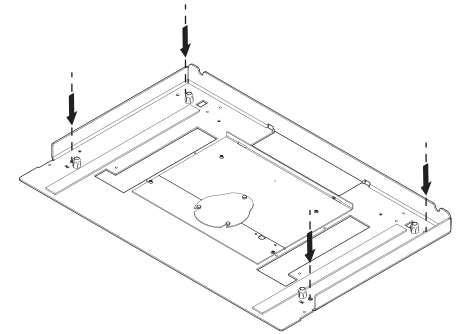

**Step 28** Insert the Stûv handles in the slots provided for this purpose on the sides of the fireplace to take it off the pallet. The handles can be placed in either direction.

**Step 29** Move the fireplace to its final location (two people).

28

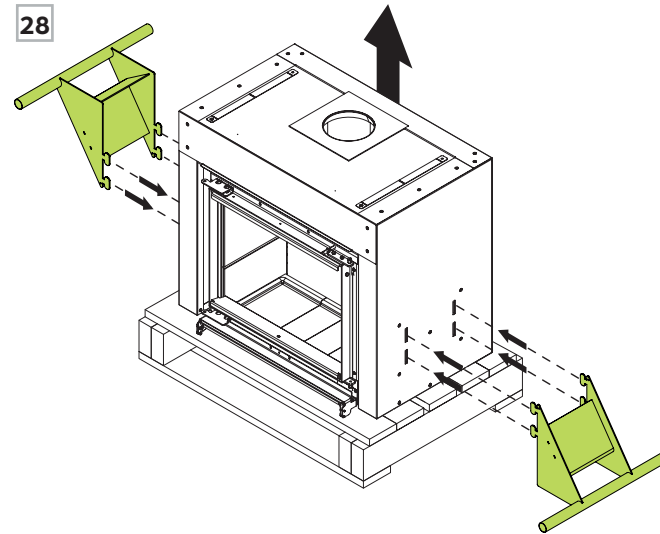

29

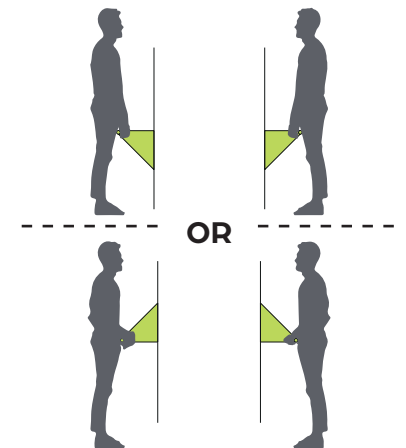

## 4.3 BASE PLATE AND CONNECTION



### NOTE

The next steps are shown without the wall to make it easier to see. These steps must be followed after positioning the base plate at its final location.

**Step 30** Slide the unit onto the base plate previously installed at its final location.

**A** The fireplace is equipped with two wheels in the back and a track to guide its placement.

**B** Two tabs, one on the right and one on the left, will stabilize the unit in the right place.

Validate **A** & **B** positionings before continuing.

If the unit will be connected to a **Ø6" chimney**, proceed to the next step.

If the unit will be connected to a **Ø7" chimney**, remove and recycle the transition plate.

**Step 31** Attach an anchor plate (not included) on the top of the shell with self-drilling screws (not included) that are maximum 2" long.

Connect the chimney while respecting the criteria in the **CHIMNEY** section of this manual.

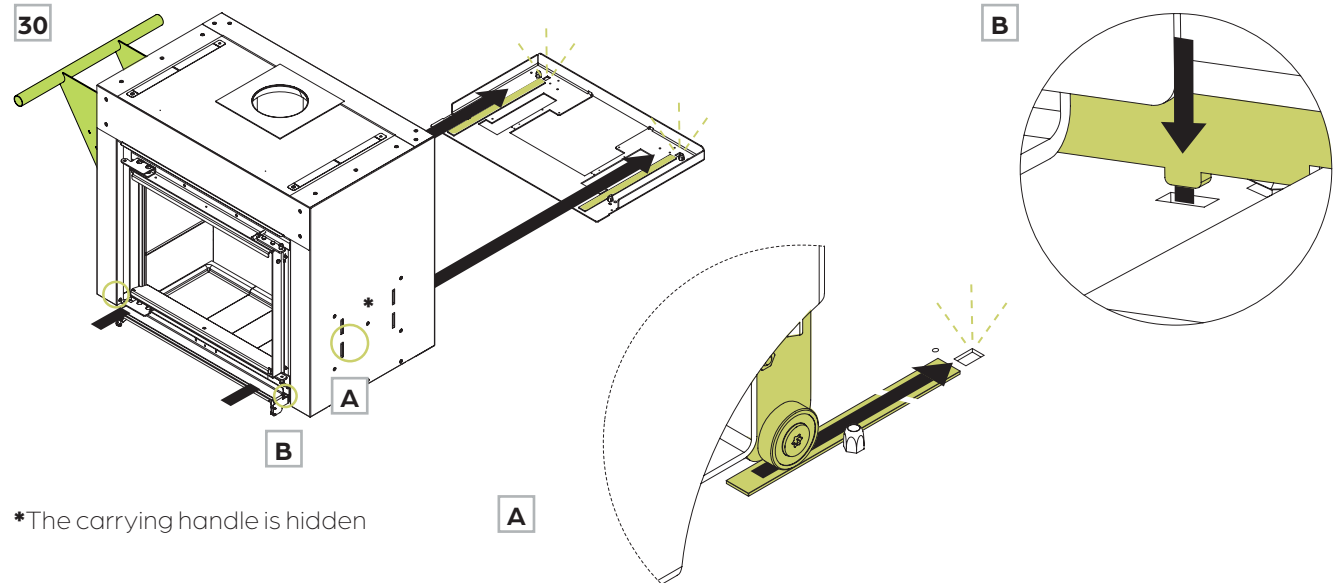

If  
Ø6"

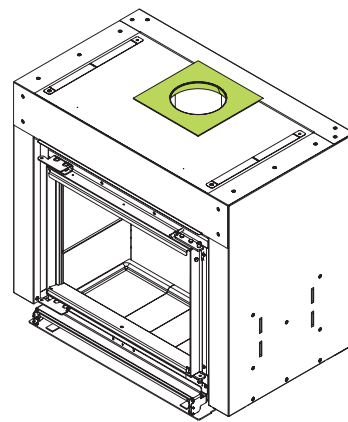

If  
Ø7"

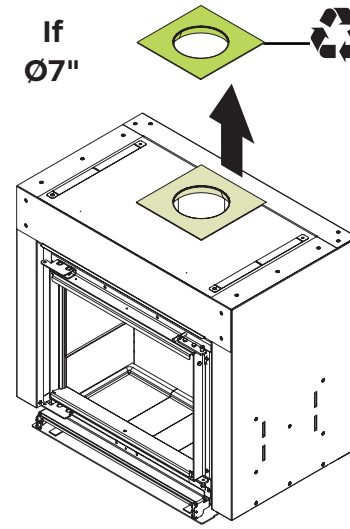

31

NOT  
INCLUDED

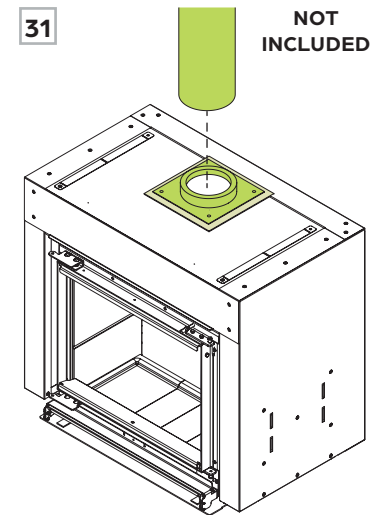



**Step 32** Install the metal structure on the wall above the fireplace. Refer to the **DIMENSIONS** section.



32

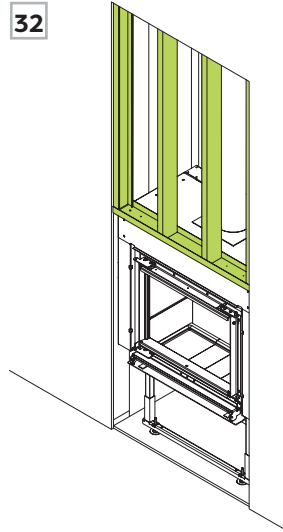

**Step 33** Refer to the installation instructions provided with the frame to finish the wall and install and adjust the frame as needed.



**Step 34** Put the door back on by inserting the hinges into the holes.

33

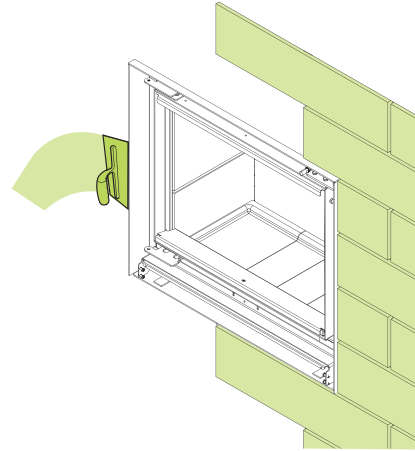

34

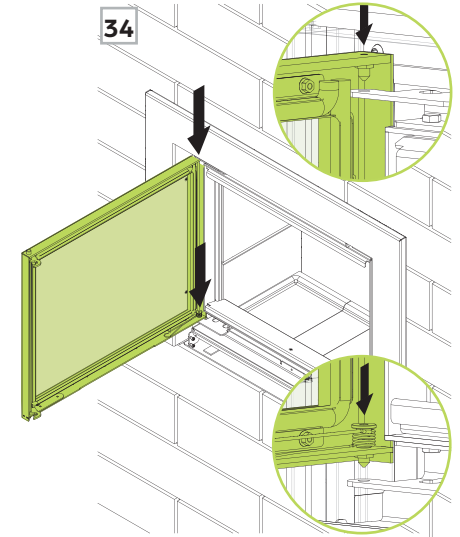

**Step 35** Check that the door is level and that it closes well.

If so, re-engage the spring, then close and lock the door.

If not, follow the steps on the next page to adjust the door.

**Step 36** Tilt the flap toward you slightly to be able to see clearly. Position the flap on the fireplace's screws. Push down, without forcing, to secure the flap.

35

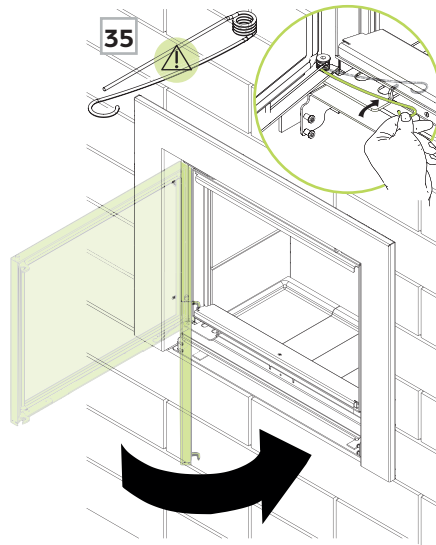

36

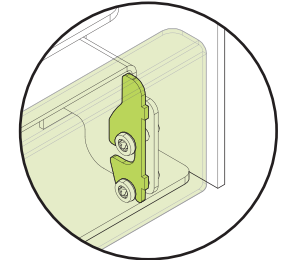
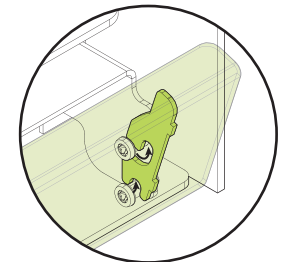
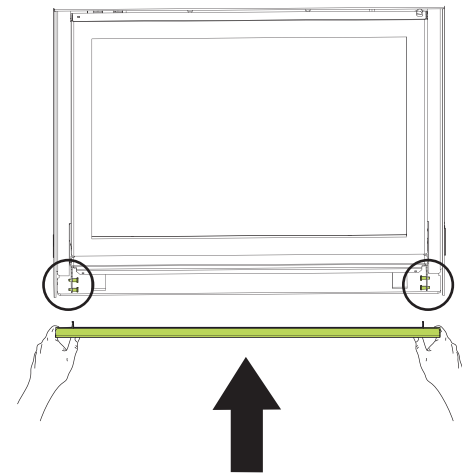



## 4.5 ADJUSTING THE DOOR



**Step 37** To make the door level, **slightly** loosen the 4 bolts holding the door hinges, at the top and bottom.

**A** If the side opposite the rotation axis is too low, push the top hinge inward. If necessary, the bottom hinge can be pushed outward.

**B** If the side opposite the rotation axis is too high, push the top hinge outward. If necessary, the bottom hinge can be pushed inward.

**Gradually** adjust the door according to the instructions above. It may take several tries to get it perfectly level.

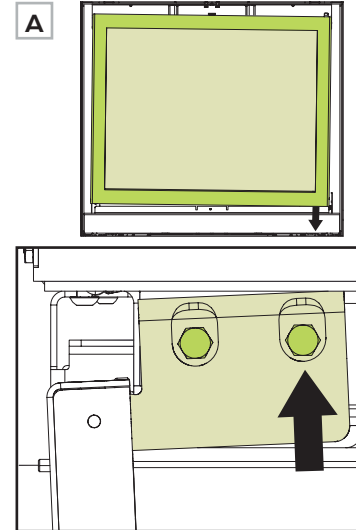
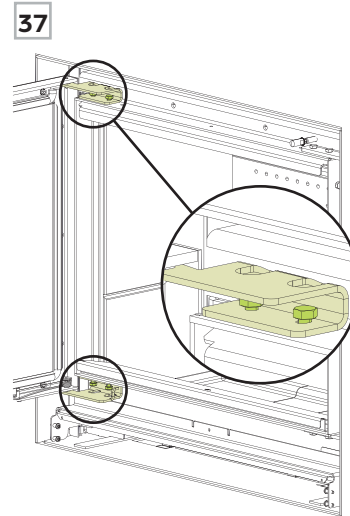

Adjustment at the top

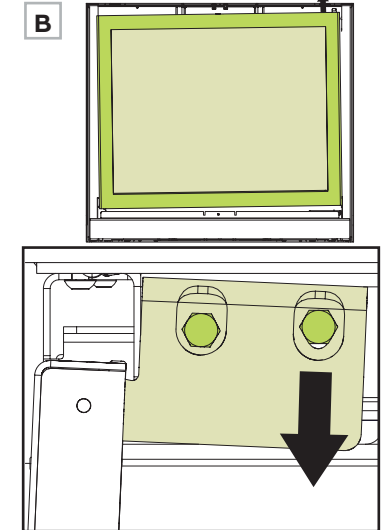

Adjustment at the top

**Step 38** When the door is level, tighten the 4 bolts.

**Step 39** The door must be loose enough to be easy to close, but tight enough to be airtight. Open and close it a few times to check that the door filler plate reinforcement is adjusted properly.

**Step 40** Also check the door's airtightness, by placing a sheet of paper in the door and closing it. Try to pull the paper out all along the door frame. If the door is airtight, you will not be able to remove the paper. If the paper moves or the door's grip is not perfect, make the adjustments indicated on the next page.

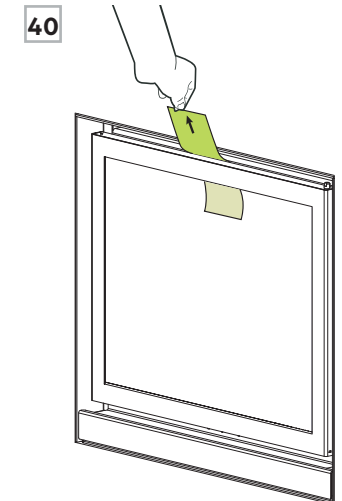
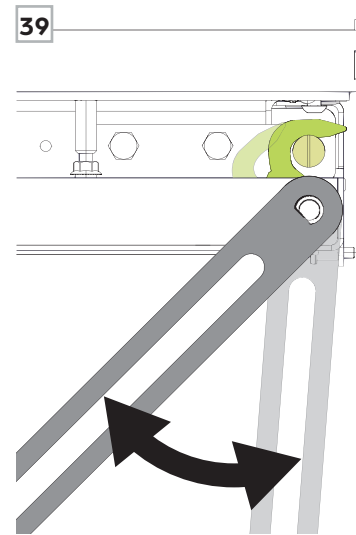
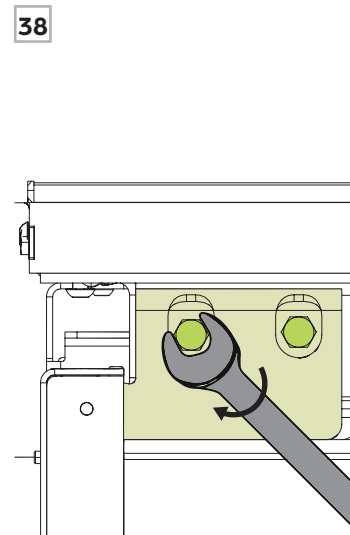

## 4.5 ADJUSTING THE DOOR



**Step 41** To adjust the door's grip or airtightness, slightly loosen the 4 bolts holding the door filler plate reinforcements at the top and bottom.

**A** If the grip is too tight, the door filler plate reinforcement cylinder has to be pushed outward.

**B** If the grip is too loose, the cylinder has to be pushed inward.

**Gradually** adjust the door according to the above instructions and then tighten the bolts.

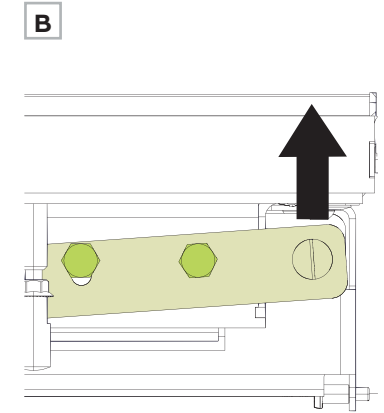
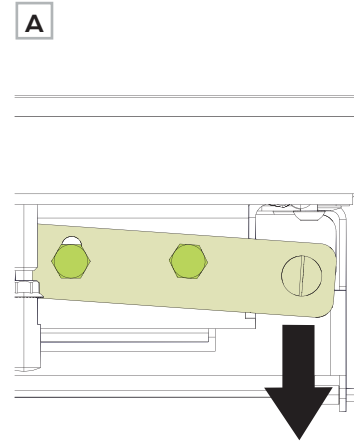
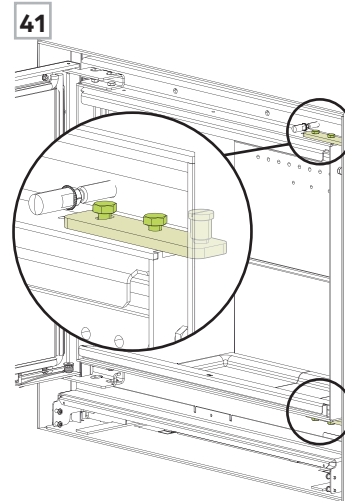

**Step 42** Recheck the airtightness by placing a sheet of paper in the door and closing it. Try to pull the paper out all along the door frame.

**Step 43** Redo the adjustment steps until the door is airtight, level and has a pleasant grip.

If it seems impossible to adjust the door, contact Stûv America's customer service department at 1-866-487-7888.

**Step 44** Re-engage the spring, then close and lock the door. Position the flap if you have not already done so.

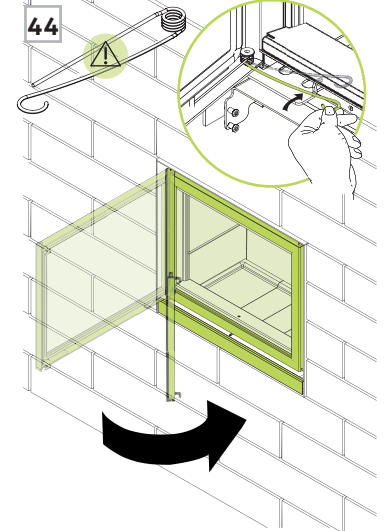
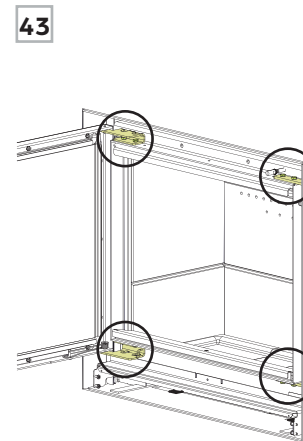
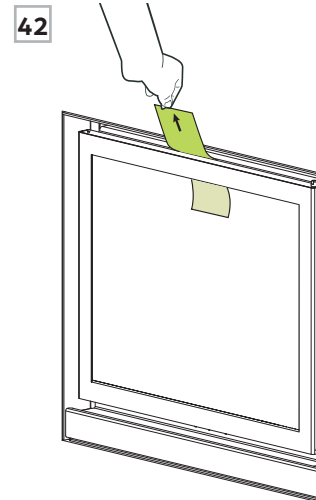

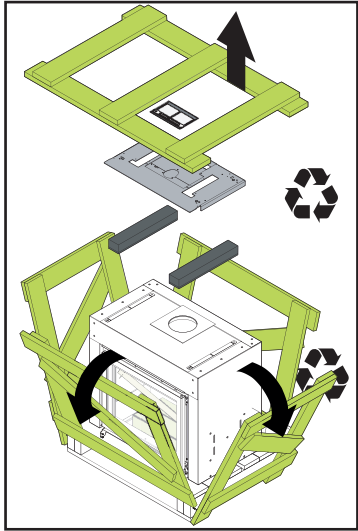

1. Unpack and discard the packaging.

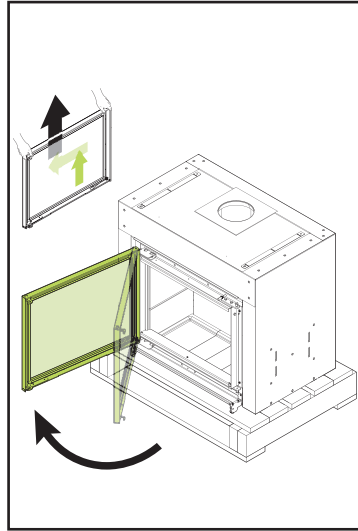

2. Remove the door to keep from damaging it.

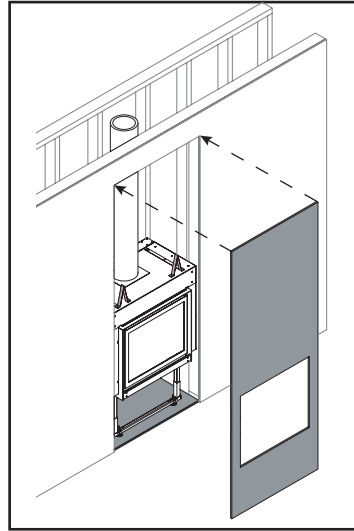

3. Erect the frame and validate the compliance of the combustible materials.

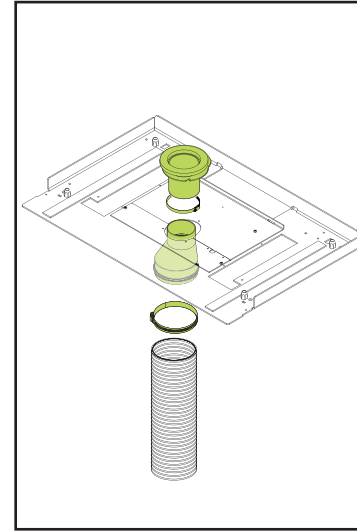

4. Connect the outside air intake if needed.

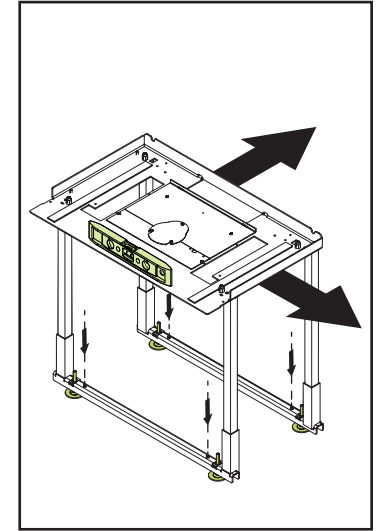

5. Position, level and affix the base plate (with or without the adjustable stand).

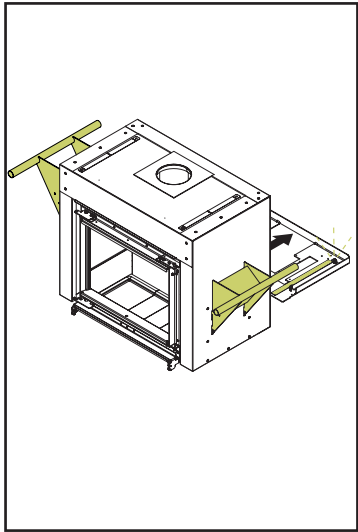

6. Assemble the fireplace and the base plate.

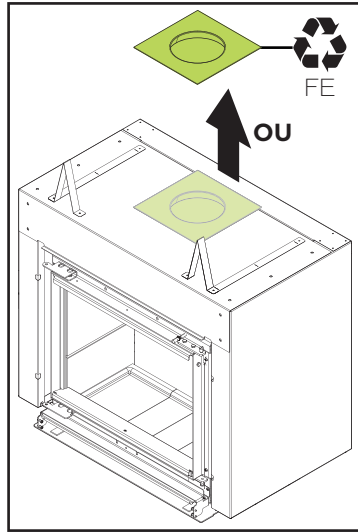

7. Install the transition plate (or not, according to diameter).

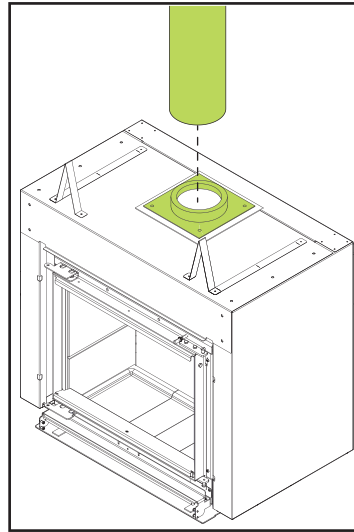

8. Connect the chimney.

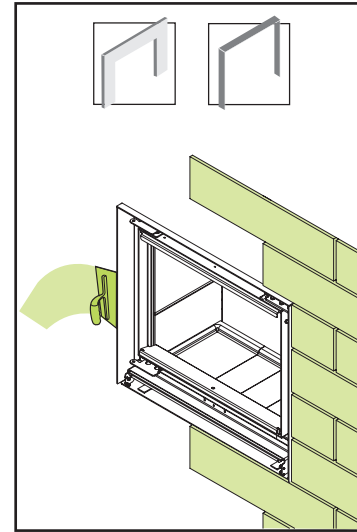

9. Install the frame and finish the wall.

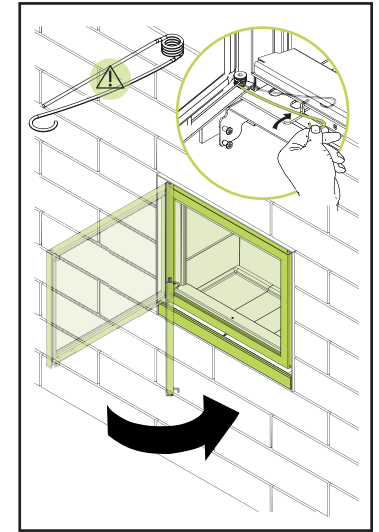

10. Put the door back on and adjust as needed.

# 5

## CHIMNEY

5.1	DIMENSIONS AND CERTIFICATION .....	41
5.2	TYPICAL INSTALLATION .....	42
5.3	MASONRY HEARTH .....	43



## 5.1 DIMENSIONS AND CERTIFICATION



### CHIMNEY DIAMETER

Only use an insulated chimney pipe that complies with standard **UL-103HT** or **ULC-S629**. A **ULC-S610** chimney pipe of the **SECURE TEMP ASHT** or **ICC EXCEL** brand can also be used. Contact the local fire department for more information before starting the work.



If the chimney is shorter than 18', the recommendation is to use a pipe with a 7" inside diameter.

### CAUTION

- Do not use makeshift means during installation. This could pose a danger, compromise safety and result in a fire.
- Do not connect the appliance to a chimney that is already connected and used by another appliance. A chimney used as an outlet for a fireplace must not be used for more than one appliance.
- Do not cut trusses, rafters or ceiling joists without consulting a building official to ensure that the building's structural integrity has not been compromised.
- It is preferable, but not mandatory, to install a 3' straight chimney section between the unit and an offset.
- If this unit is not installed properly, a fire may result. To reduce the risk of fire, follow the installation instructions.
- Contact the local authorities to obtain a building permit and information about all applicable regulatory requirements.

### CHIMNEY LENGTH

#### MIN. 15' / MAX. 45'

It is recommended that the height of the chimney be between **minimum 15'** and **maximum 45'**, measured from the top of the unit to the bottom of the rain cap. This height impacts the draft and the efficiency of the unit. If this height is impossible, contact Stuv America technical service.

If the chimney is shorter than 18', use a 7" chimney adapter.

**Before connecting**, make sure the fireplace is in its final location and is level (see page 24 if needed).

After affixing an anchor plate to the insulated shell (see page 34), connect to the chimney by following the steps on the next page.

Calculate the number of chimney sections needed (starting from the anchor plate), based on the information on this page, and gather all of the components needed.

Carefully read the installation manual provided with your chimney before installing.

### IMPORTANT

It is preferable, but not mandatory, to install a 3' straight chimney section between the unit and an offset. In that case, **a straight vertical section** must be installed after the angled section.

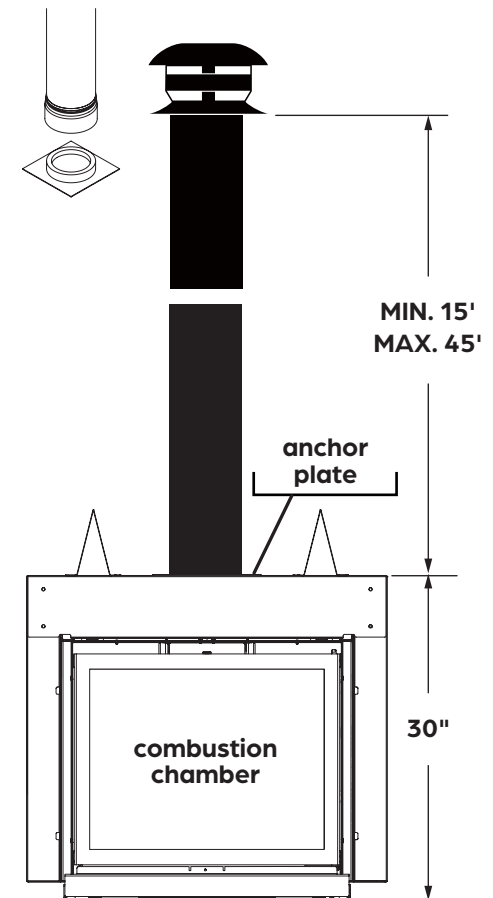



## INSTALLATION DIAGRAM

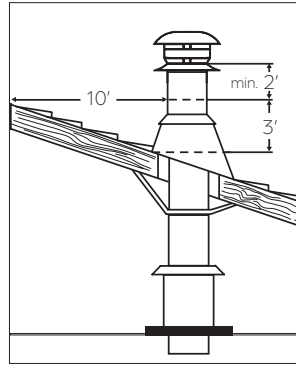
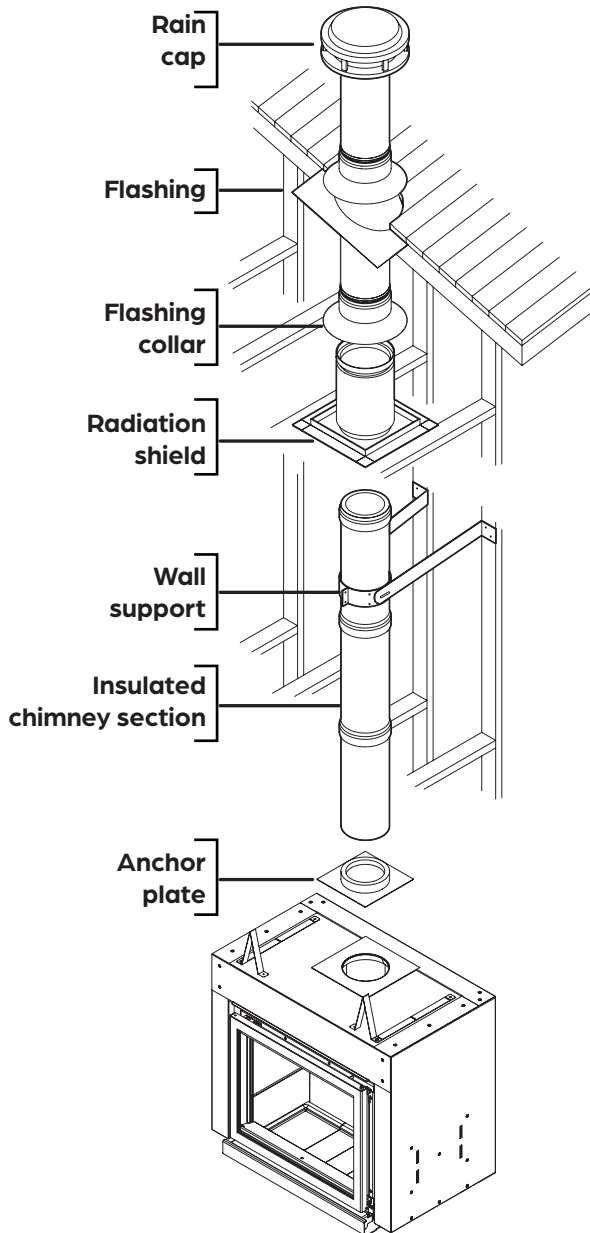

## INSTALLATION PROCEDURE



### CAUTION

Care must be taken during the chimney's installation. Shortcuts or compromises may result in safety hazards or even a fire.

Carefully read the installation manual provided with your chimney before installing. Some configurations may change the order of the steps.

**Step 1** Once the fireplace is in place, create an opening between the ceiling(s), aligned with the chimney sections used. The cutout must be sufficiently large to fit the chimney pipe.

**Step 2** Install a radiation shield under each floor/ceiling the chimney crosses. In the attic space, install a radiation shield and a flashing collar.

**Step 3** Connect the chimney pipe sections all the way to the ceiling, from the first section installed previously. Follow the manufacturer's recommendations.

**Step 4** Once at roof height, install a roof radiation shield. The shield must be installed so that it extends 1' above the roof line.

**Step 5** Install the flashing. If the chimney is enclosed up to the roof, use ventilated flashing. If the chimney is not enclosed up to the roof, use regular flashing.

**Step 6** Gasket the joint between the roof and the flashing using asphalt-based gasketing compound. For a pitched roof, place the flashing under the upper shingles and over the lower shingles. Nail the flashing to the roof using roofing nails.

**Step 7** Install the flashing collar around the chimney, just above the flashing. Gasket the collar with silicone gasketant. **(Do not use asphalt-based gasketing compound).**

**Step 8** Install and secure the rain cap to the top of the chimney.

## 5.3 MASONRY CHIMNEY



The installation of a Stûv fireplace in a masonry chimney still requires the installation of a section of a chimney section above the fireplace until it connects to the listed liner that will line the inner surface of the masonry chimney. A rigid stainless steel liner must be installed inside the fired clay liner inside the masonry chimney. The rigid liner does not replace the fired clay liner in any way. You can use any liner listed to **ULC-S635, ULC-S640 or UL-1777 standards**. You must ensure that the chimney section and the liner are strongly secured together. A masonry adapter FO-FDM(-) has been designed specifically for this use and is available from a dealer. This adapter attaches with 3 rivets (supplied) to the rigid liner and with 3 screws (supplied) to the chimney.

Once the mortar is in place, the joint between the chimney and the rigid liner should not be visible in order to isolate the heat released through the liner from the fireplace enclosure. You must install a section of chimney of at least 46 cm after the chimney elbow.

The highest point of the chimney, where the chimney enters the masonry chimney, must be no less than 31 cm from combustible ceiling materials.

If ceiling height permits, install one of the chimney lengths directly on the fireplace, before the elbow. If a flexible liner is used, the cleaning should be carried out carefully so that it is not displaced.

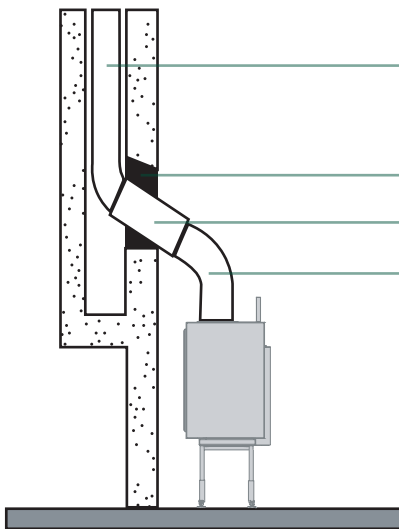

Listed liner to ULC-S635,  
ULC-S640 or UL-1777

Mortar

Chimney (min. 18")

Chimney elbow

Observe clearances according  
to NBC or NFPA 211

### ! ATTENTION

If you plan to use an existing masonry chimney, you must have it inspected by competent authorities to confirm the following points:

- The masonry chimney is properly constructed, fully lined and complies with municipal by-laws and the National Building Code of Canada (NBC) or National Fire Protection Association (NFPA 211) standard.
- The masonry chimney has been completely cleaned of all soot and creosote residue and has been inspected to confirm that it is still in good working order. There is no insulation of any kind in contact with the masonry chimney and there is no insulation of any kind trapped anywhere in the chimney.
- All necessary clearances around the masonry chimney, along the entire length of the masonry chimney, are complying with CNB or NFPA 211. If the masonry chimney is enclosed behind drywall boards, openings must be made to confirm all clearances.
- The masonry chimney will be used only for the fireplace and not for any other appliance.
- If major repairs are required to meet the above mentioned points, a new masonry chimney will have to be built.

To make a hole in the masonry chimney and connect it to the fireplace, we recommend that you follow these steps:

- Determine and mark where the chimney is to be inserted into the masonry chimney. Using a large masonry drill bit (3/4 - 2"), drill a hole exactly in the centre of the oval line. Using a masonry hammer and drill, gradually widen the hole to the desired size. Remember to work from the centre of the hole to the outside. Be particularly careful when drilling the fired clay liner behind the brick as the other three sides must remain in place.
- Slide the stainless steel liner from the top of the chimney down. If you are using a rigid liner, you will need enough space to fix an elbow with at least 2 rivets. If the rigid liner does not slide easily or if the masonry chimney has an interior opening of less than 10" X 10", a listed flexible liner can be used with a flexible/rigid adapter (LM-7LAF) available from a chimney dealer.
- Install the rigid liner elbow and masonry adapter at the lower end of the liner.
- Push the fireplace forward to install the chimney (elbow and length) and then push the fireplace back into place while connecting the chimney to the masonry chimney adapter.



# 6

## USE

6.1	WOOD SELECTION .....	45
6.4	STARTING THE FIRE .....	46
6.3	RELOADING THE FIRE.....	48
6.4	ASH REMOVAL .....	48



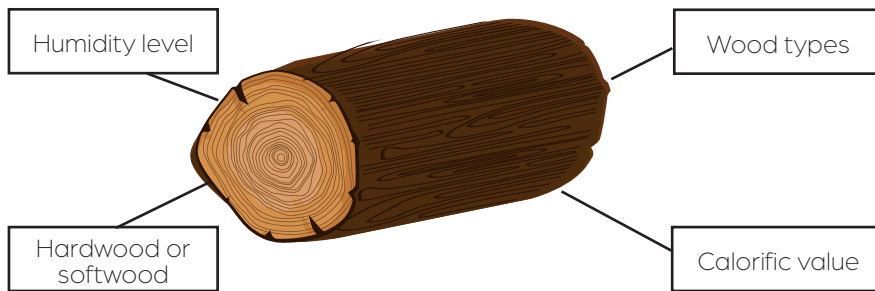

## HUMIDITY LEVEL

It is essential to use **dry wood** that has a moisture content of **less than 18%**. This will ensure **more efficient** and **clean combustion**.

Using **wet or semi-dry wood** with a moisture content **higher than 18%** will result in mediocre and less efficient combustion. The fire will be smaller and difficult to start. It will release a great deal of **black smoke** and **pollution** into the air and also sully your glass and chimney pipe.

### To choose dry wood, use a moisture meter or check if...

- The wood is lightweight and slightly split
- You hear a snap when banging one log against the other
- The bark comes off easily
- There are cracks from the centre to the edge

## HARDWOOD OR SOFTWOOD

The harder a wood is, the more heat it will produce and the slower it will burn (at equivalent moisture content).

Softwood can be used as kindling over hardwood. It burns more quickly (at equivalent moisture content) despite its lower calorific value.

- **Hardwood:** oak, beech, elm, ash, acacia, hornbeam, maple
- **Fruit tree wood:** walnut, cherry, pear, apple, olive
- **Softwood:** poplar, birch, linden, locust, chestnut
- **Resinous wood:** maritime pine, spruce, Scots pine, fir, larch

## WOOD TYPES

**Ash and beech** are recommended as firewood as they dry quickly and are easy to find. They must be stored under a shelter immediately after being cut and split, otherwise they rot very quickly and lose their calorific value. They are easy to light and produce very bright, lively flames.

**Maple** has a good calorific value. It produces fires and embers that last a long time.

**Oak** is an excellent fuel, but unlike other wood species, it has to remain uncovered for two years to allow the rain to remove the tannins it contains. Then it has to be stored under shelter for another year or two before it can be burned. Small oak branches have a high sapwood content, which burns too quickly. Oak burns slowly, produces a calm fire and beautiful embers. It is ideal for barbecuing and for moderate fires.

**Hornbeam, cherry and fruit trees** are excellent fuels, but are rare. These are hardwoods. They produce beautiful, harmonious and calm flames, and beautiful embers. Ideal for a barbecue or a calm fire.

**Birch, linden, chestnut, poplar and black locust** are broad-leaved trees with soft wood. They produce beautiful, harmonious, but bright flames and few embers. Because they burn quickly, they can be used to start (or restart) the fire. Caution: Poplar produces abundant and volatile ash while black locust produces significant sparks.

**Resinous woods (not recommended)** generate a lot of heat, but they burn quickly. They throw sparks and the resins they contain cause build-up in the chimney.

## CALORIFIC VALUE

Each type of wood has a different calorific value and all burn in different ways.

**We strongly encourage the use of hardwoods** such as hornbeam, maple, oak, ash, elm and beech. They produce beautiful flames and plenty of embers that glow for a long time.



### CAUTION – NOT TO BE USED

#### Burn only firewood. Do not burn:

- Garbage
- Lawn clippings, yard waste or unseasoned wood
- Materials containing plastic, petroleum-based products, gasoline, liquid fuel or rubber, including tires
- Waste petroleum products, paints or paint thinners, or asphalt products
- Industrial solvents
- Flammable liquids such as naphtha and motor oil
- Painted wood, varnished wood or chemically treated wood
- Materials containing asbestos
- Construction or demolition debris
- Salt water driftwood or other previously salt-water saturated materials
- Railroad ties or pressure-treated wood
- Manure or animal remains
- Paper products, cardboard, plywood, or particleboard. The prohibition against burning these materials does not prohibit the use of fire starters made from paper, cardboard, saw dust, and similar substances for the purpose of starting a fire in this unit
- Any substance that emits dense fumes and strong odours

The heat produced by these materials is too great and can damage the appliance, in addition to causing soot to form on the glass and on the inside of the chimney pipe. These materials produce toxic and polluting fumes, such as carbon monoxide, which can be hazardous to health. Burning these materials may result in release of toxic fumes or render the heater ineffective and cause smoke.

**Composite logs (ecological):** Composite/ecological logs are to be avoided. They sometimes emit residues that sully the mechanisms and cause the appliance to age poorly.

Stûv appliances are designed for domestic use and must never be used to incinerate garbage of any kind.

This wood heater has not been tested with decorative sets (logs, pebbles) for unvented gas fireplaces. To reduce the risk of fire and/or injury, it is prohibited to install a decorative set in the combustion chamber of the appliance.



### CAUTION

**Read the safety instructions on page 7 before using the fireplace.**

Upon first use, some smoke or odours may be produced. **Ventilate the room well.**



### In case of a chimney fire

1. Call the fire department.
2. Put out the fire with a type A or ABC extinguisher (powder, foam or water and additive). Avoid using a bucket of water or any other hazardous method to put it out.
3. Air out the room in which the unit is located.
4. After a chimney fire, have the chimney cleaned and inspected by a professional.
5. Make any repairs necessary before using the unit again.

If the outside temperature is higher than the inside temperature, load more paper and more kindling to properly heat the chimney pipe and thus counter the temperature imbalance. First ignite balled-up pieces of paper and about 1 to 1 1/2 lb. of kindling ±3/4 sq. in.-thick.

The maximum load to avoid overfiring is **2x the weight of the hourly consumption**. Refer to the table on page 5.



### IMPORTANT

Store the wood in a weatherproof location to keep it dry. Do not store it in the risk area, fireplace loading area, ash removal area or inside the mandatory clearances indicated in the **DIMENSIONS** section.



### CAUTION

The fireplace must always be operated with the door closed. Otherwise, smoke and flames could come out of the opening and cause significant damage.

Only open the door to start the fire or to add wood.

**Step 1** Using the door handle provided with the unit, open the door by turning the door handle.

Allowing the door to slam could break the glass. Do not start a fire if the glass is broken.

**Step 2** Place the wood logs in the combustion chamber using the top-down lighting technique as shown for better combustion. Do not place the logs too close to the glass.

**Step 3** Light the fire.



### ATTENTION

It is recommended to use fire starters made from sawdust or wood fiber, without chemical and toxic additives. Paraffin or other waxy substances can block the air supply system.

**Step 4** Leave the door ajar for minimum 20 minutes. This helps create a better draft when starting a fire and prevents smoke condensation and soot deposits. Close the door once the fire is burning well.

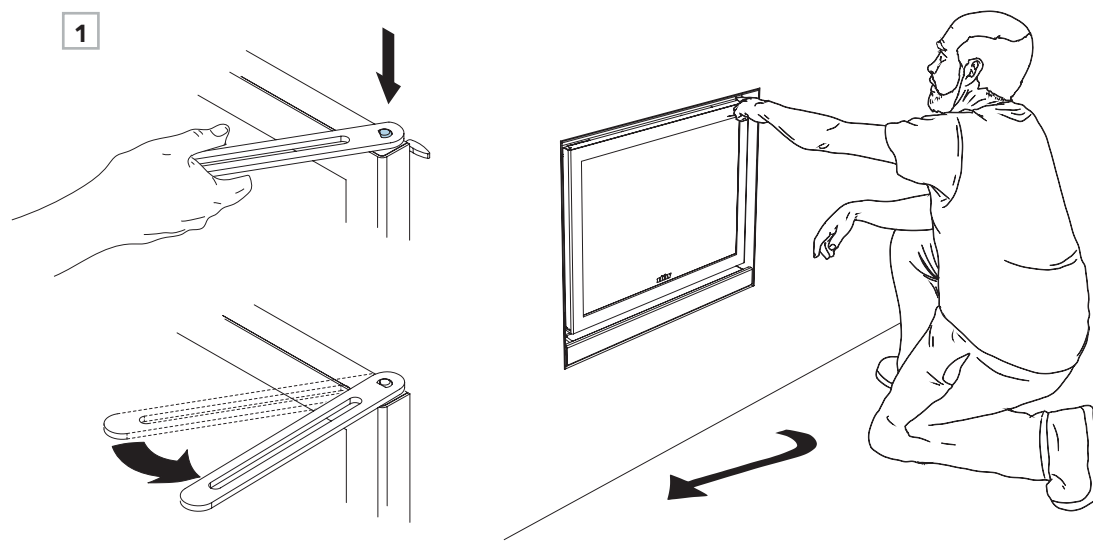

### NOTE

Burning one log at a time increase the amount of embers and coal. While burning two or more logs, the combustion is optimized and this will reduce unburned residues.

2

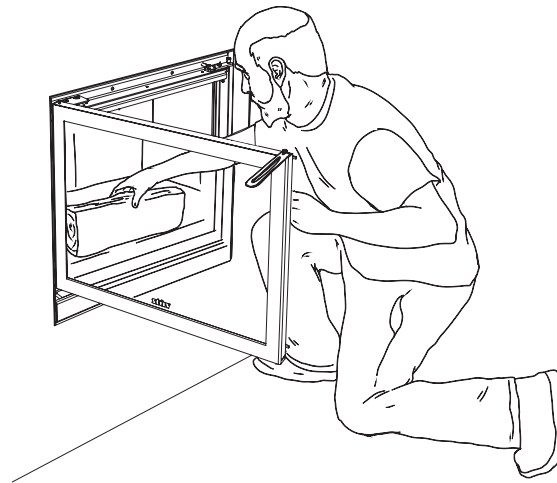

3

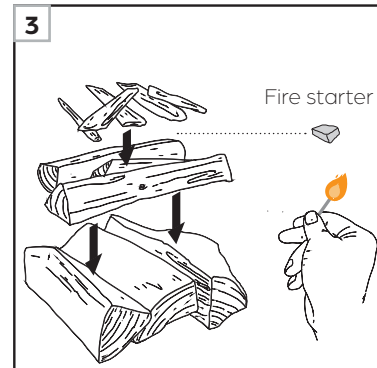

4

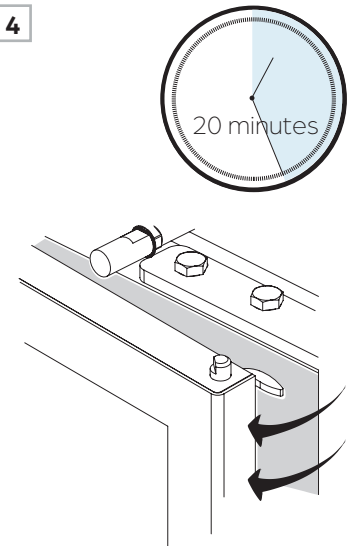

## 6.3 RELOADING THE FIRE



**Step 1** Never leave the door handle on top of the cube shell or grip cylinder. It will get very hot and could damage the paint.

**Step 2** Add wood using the Stûv glove provided with the unit.

Do not stir the wood or move it around while it is burning. Use a poker if necessary.

**Step 3** Only fill the combustion chamber halfway with solid fuel.

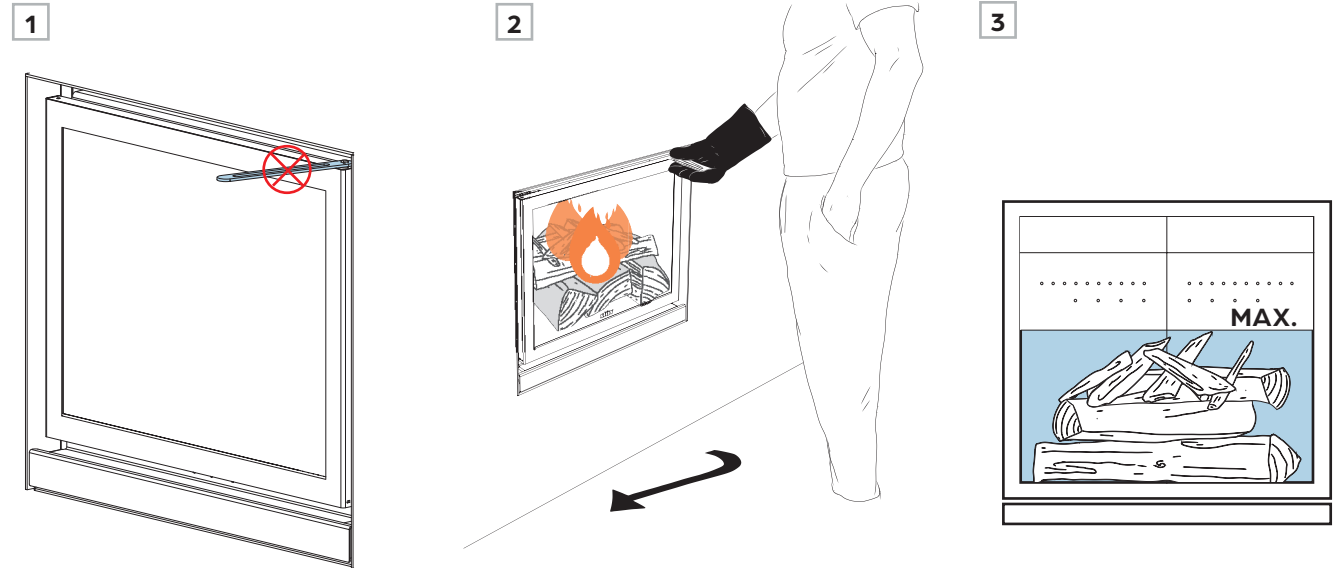

## 6.4 ASH REMOVAL

**Step 1** Wait until the ashes are cold to be able to safely open the door.

**Step 2** Use an ash shovel to remove the ashes. Place them in a metal bucket.

**Step 3** Place the bucket filled with ashes on a non-combustible surface. Be sure to keep it away from any combustible materials.

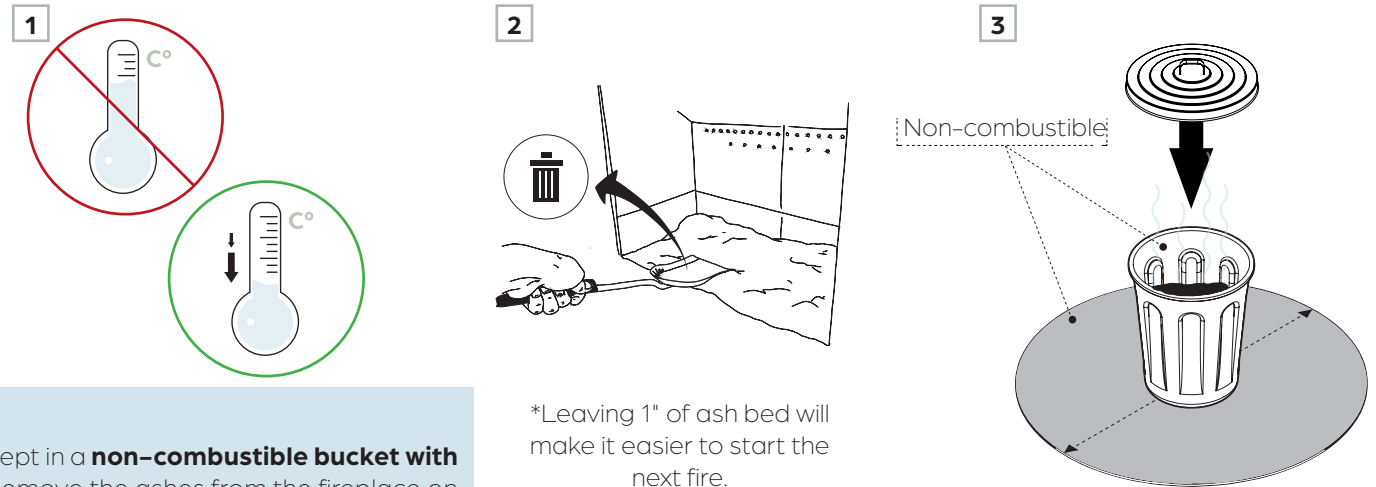

### NOTE

Before disposing of the ashes, they should be kept in a **non-combustible bucket with a tight lid** until they have cooled completely. Remove the ashes from the fireplace on a regular basis. Burning ashes can damage the glass's lower gasket. This deterioration is not covered by the warranty.

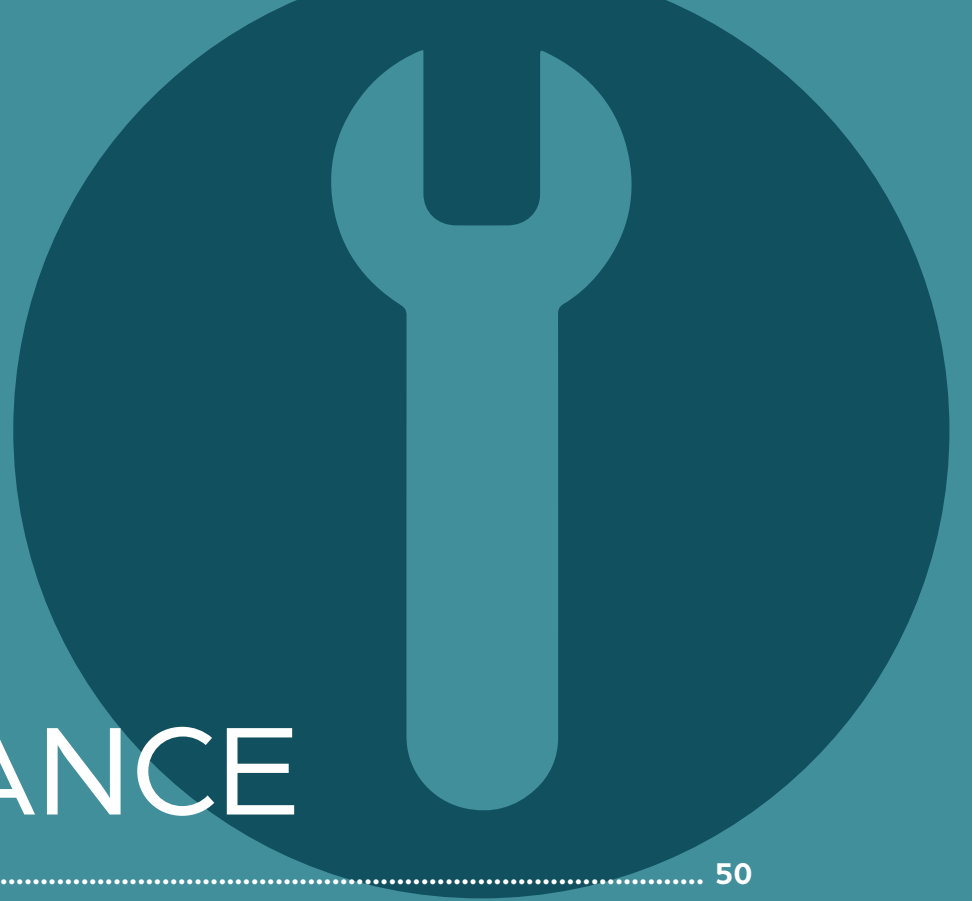

# 7 MAINTENANCE

7.1	REGULAR MAINTENANCE .....	50
7.2	REPLACING COMPONENTS.....	51
7.3	CREOSOTE AND CHIMNEY-SWEEPING .....	54



## CAUTION

Do not conduct maintenance while the unit is hot. Wait until it has cooled completely.

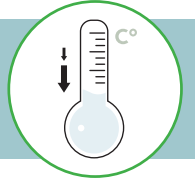

### Every year, perform annual maintenance on the unit:

- Vacuum the ashes from the joint section
- Check the condition of the door's gasket
- Check the condition of the glass's gasket

### Follow the steps on the following pages to conduct these checks.

Clean the glass when the unit is cool. Never use abrasive cleaners.

- Use the door handle to open the door 90°.
- If necessary, protect the painted parts of the unit and the floor finish.
- Clean with a non-abrasive glass cleaner or clear water. You can also use ashes mixed with water to remove accumulated soot.

During the heating season, have your chimney regularly inspected by a professional. It is recommended that you have your chimney swept twice per heating season to prevent creosote build-up.

Remove excess ash after each use. Do not wait for the ashes to overflow from the fireplace. Excess ash can obstruct the supply of fresh air during combustion and can damage the gaskets.

**Ash removal is explained in the *USE* section of this manual.**

**Stûv recommends using genuine replacement parts.** Using a substitute may affect the unit's operation and will void the warranty. **Contact a Stûv dealer** in the event of deterioration of the parts.

For all other parts that need to be replaced, but whose disassembly steps are not included in these instructions, contact an authorized Stûv America dealer.

To vacuum the ashes in the joint section:

**Step 1** To remove the flap, slide it upward, then turn it slightly toward you.

**Step 2** Vacuum inside and then put the flap back.

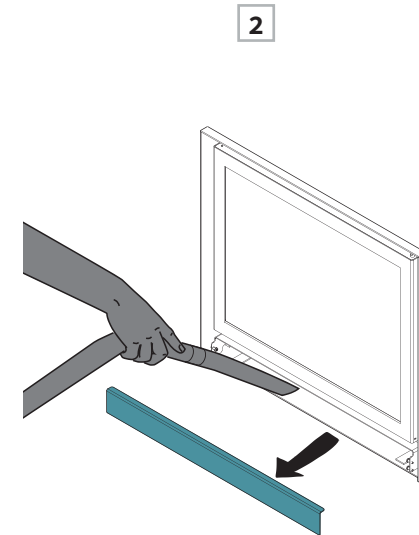
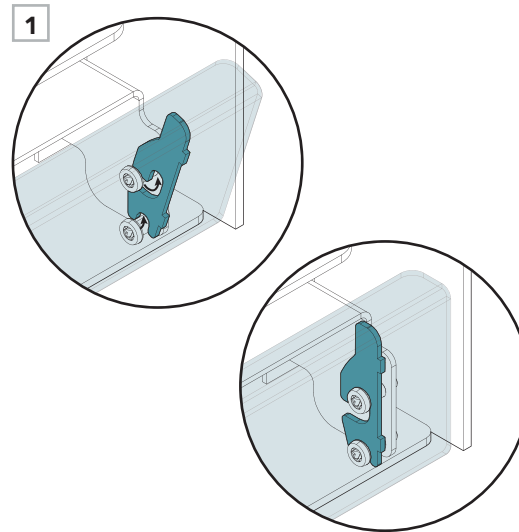

## 7.2 REPLACING COMPONENTS



**Step 1** The next steps explain how to disassemble the parts that make up the door.

1

#	DESCRIPTION	16-58	16-68	16-78
1	full door	PW1400804000	PW1400804100	PW1400804200
2	door frame	PW1499721000	PW1499723400	PW1499725800
3	glass and gasket kit	PW1400601400	PW1400601500	PW1400601600
4	glass gasket	PW1400503300	PW1400503400	PW1400503500
5	gasket clamps and nuts	PW1400402900	PW1400403000	PW1400403100
6	door gasket	PW1400504900	PW1400505000	PW1400505100
7	door latching kit	PW1499717000		
8	door latch spring	PW5511100600		

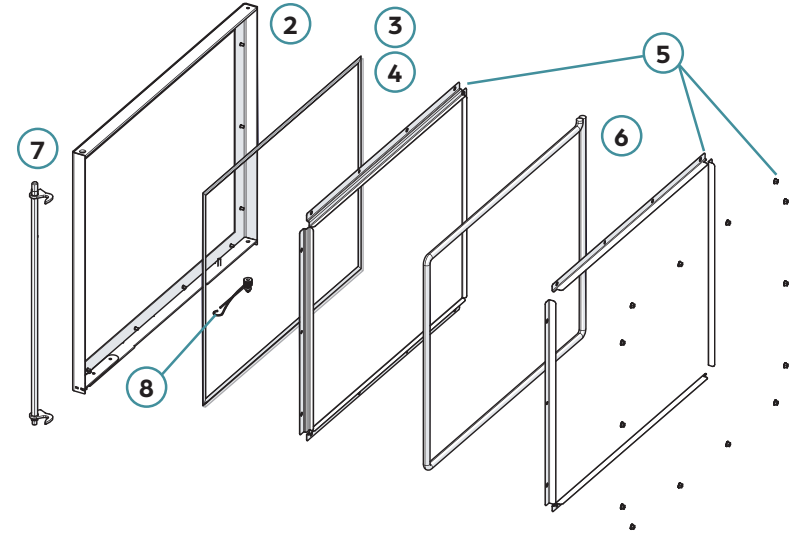

Follow the next steps for all maintenance performed on the unit.

**Step 2** Use the door handle to open the door 90°.

**Step 3** Locate the spring at the bottom of the door, near the rotation axis. Disengage the spring by pushing it down and pulling forward.

**Step 4** Remove the door and put it in a safe place where it will not get damaged.

2

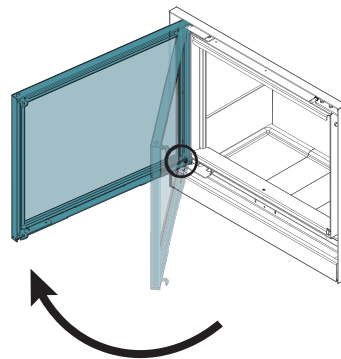

3

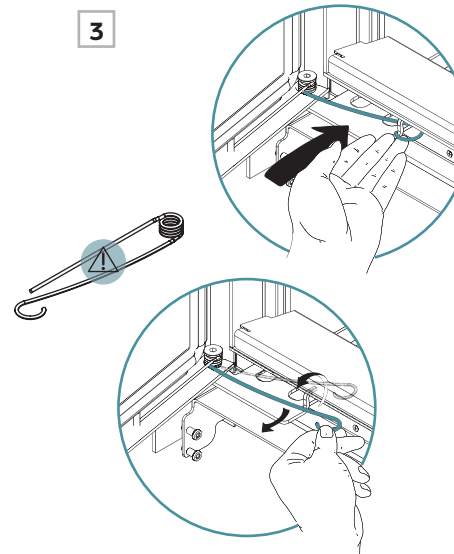

4

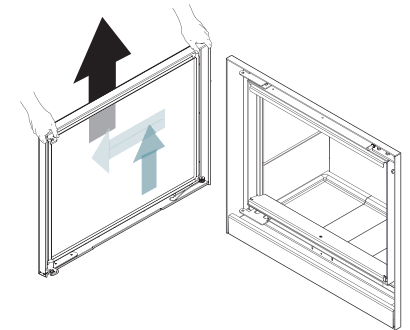

## 7.2 REPLACING COMPONENTS



**Step 5** Place the door on a protective fabric to protect the paint and to be able to continue disassembling it more comfortably.

**For all maintenance performed on the door's components**, follow the next steps until you reach the component to service or change.

**Step 6** Locate the black door gasket in the gasket clamps.

**Step 7** Gently pull on the gasket to remove.

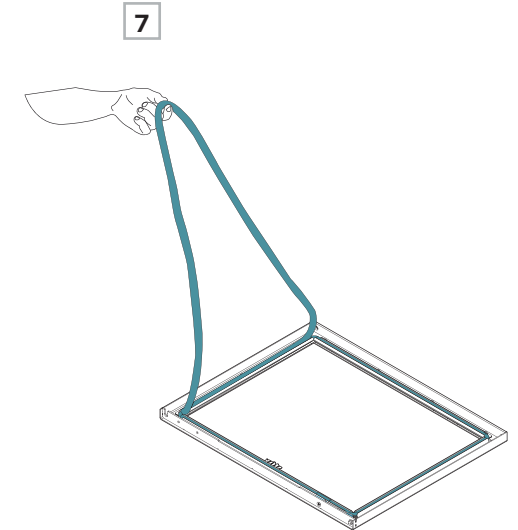
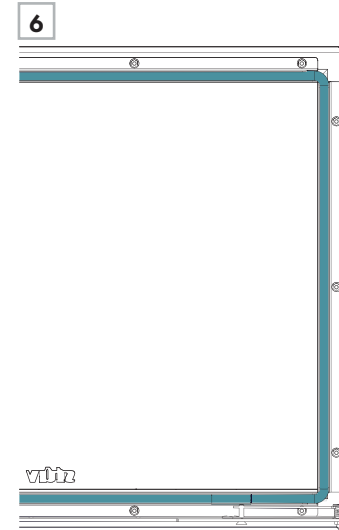
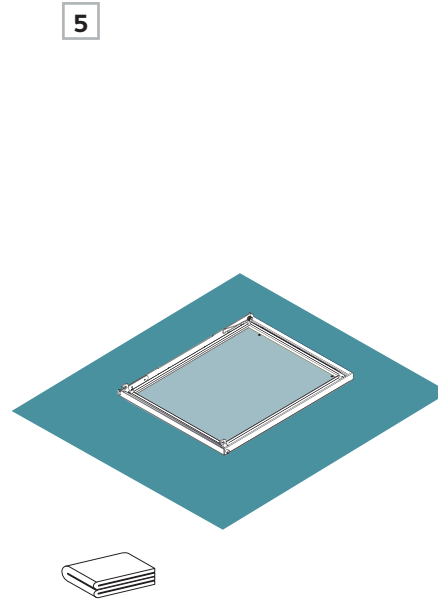

**Step 8** Several of the door parts can be modified. Here are the three work areas.

**Step 9** The first part that can be removed is the closing axis. This pin along the frame can be unlocked by removing two screws.

**Step 10** Remove the closing axis by lifting the bottom part and sliding it upward, out of the door frame.

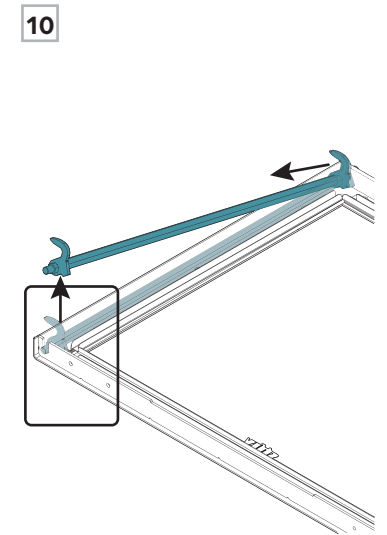
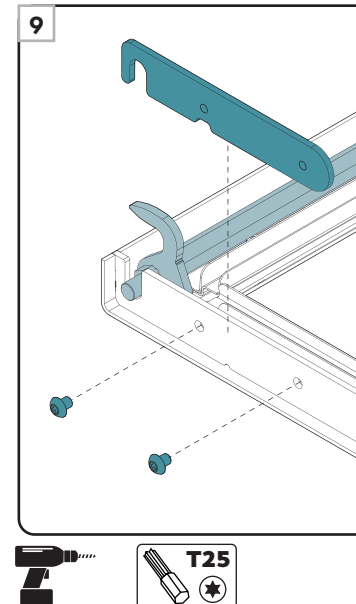
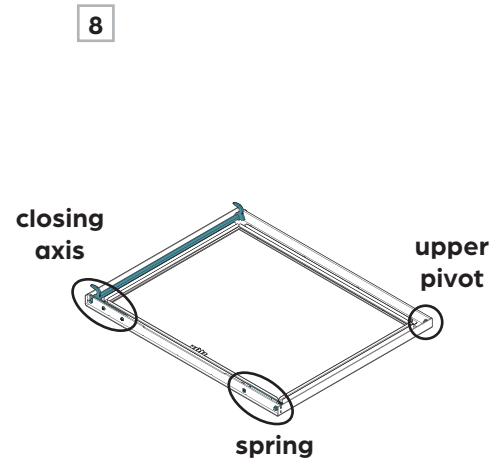





**Step 11** Only remove the upper pivot **if it is damaged**. If needed, use a 10 mm hex socket to unscrew the door.

**Step 12** The spring is supported in two places. The straight pin is behind a screw (use a 3 mm Allen key) while the spring's cylinder is wrapped around a screw (5 mm) and a pivot (10 mm).

**Step 13** Remove these three pieces of hardware to change the spring.

**Step 14** Unscrew the nuts to remove the gasket clamps and glass retaining clips.

**Step 15** The glass is the last component to disassemble. Check the gaskets and change them or the pane if needed.

Replace glass only with Stûv's ceramic glass 4 mm thick, able to withstand high temperatures.

MODEL	GLASS
16-58	439 mm x 466 mm
16-68	439 mm x 566 mm
16-78	439 mm x 666 mm

**Step 16** Follow the steps in reverse to re-assemble the door and reattach it to the appliance.

- Replace the glass and gasket.
- Screw the gasket clamps back on with the nuts.
- Re-place the closing axis and screw it back on.
- Reinsert the door gasket.
- Put the door back on its hinges.
- Screw the spring on and re-engage it.
- Close and lock the door.

11

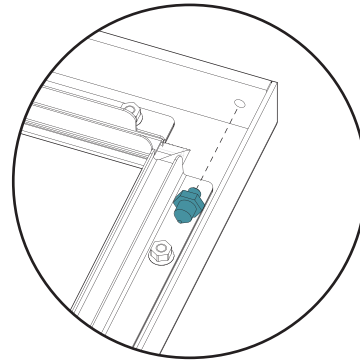

12

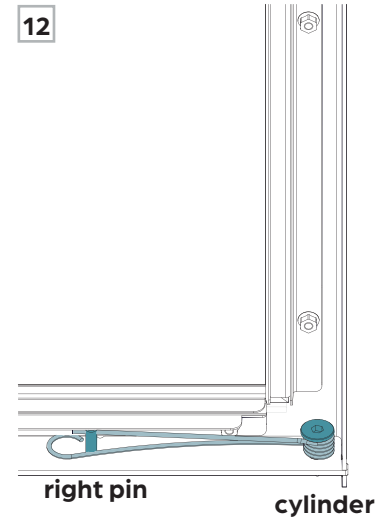

13

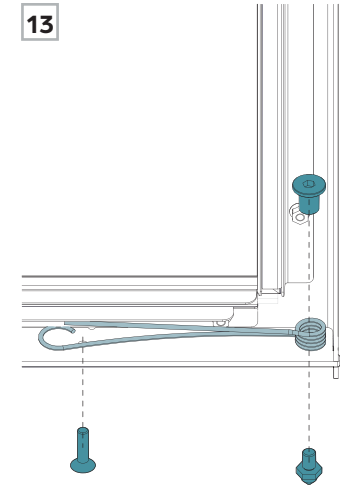

14

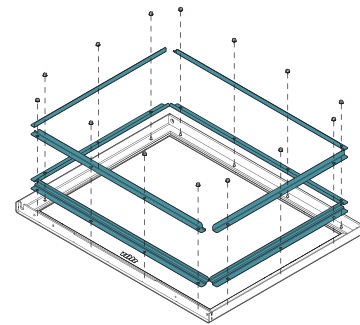

15

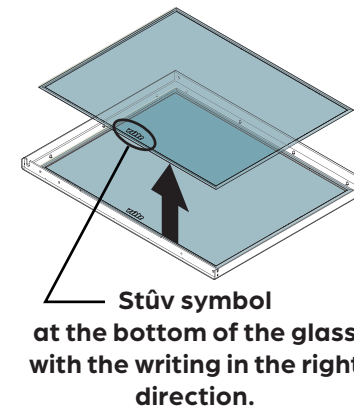

16

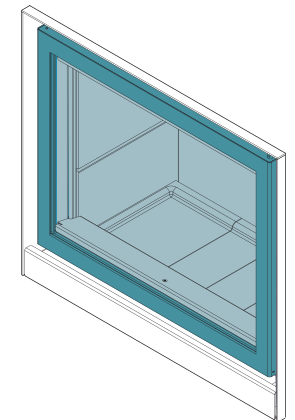



### Chimney-sweeping steps

Wait until the unit has cooled completely before performing maintenance.

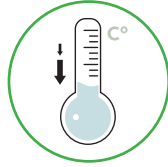

If the sweeping is being done **from the roof**:

- Use the door handle to close and lock the door.
- Sweep according to your country's regulations.

If the sweeping is being done from **inside the house**:

- Open the door fully or even remove it if needed.
- Remove the top vermiculites supported by the baffles (follow the steps at the bottom of the page).

**Creosote** is a thick, black residue that forms due to incomplete combustion of wood. It can be brittle or smooth (vitrified). During slow combustion, wood releases tar droplets that condense on the cold chimney lining. The shape of the residue varies with time and the internal temperature of the lining on which the creosote vapours condense.

This build-up of creosote can be very hazardous. When ignited, it produces an extremely hot fire in the chimney. Have your chimney professionally **inspected twice during the heating season** to assess whether or not a creosote build-up has occurred. If so, remove any built-up residue to **reduce the risk of a chimney fire**.

It is recommended that the unit's main user establish a chimney maintenance routine. Check for creosote build-up on a daily basis to get a good idea of how often the chimney needs to be swept for safety. The hotter a fire burns, the less creosote will build up. Weekly sweeping may be necessary in milder weather, while monthly sweeping can be sufficient during the colder months. **Contact your local or provincial fire department for information on how to put out a chimney fire.**

To sweep from inside the unit, the deflector's profile and vermiculites must be removed.

**Step 1** Remove the deflector's profile by pivoting it slightly toward you. **The longer side of the profile must be over the vermiculites.**

**Step 2** Remove the vermiculites with a similar movement. Take care as they come apart easily. **The grooves on the vermiculites must be on the top.**

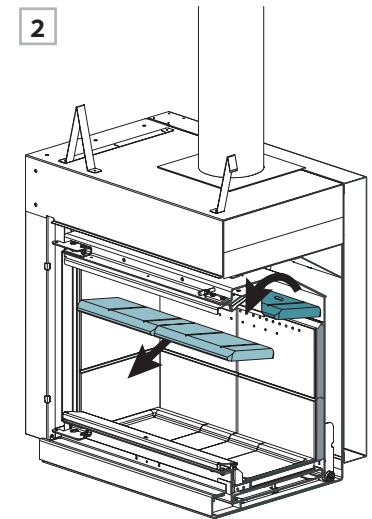
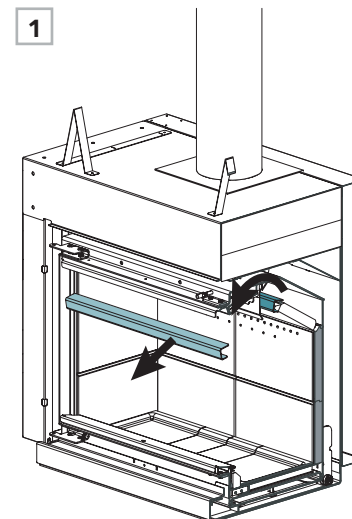
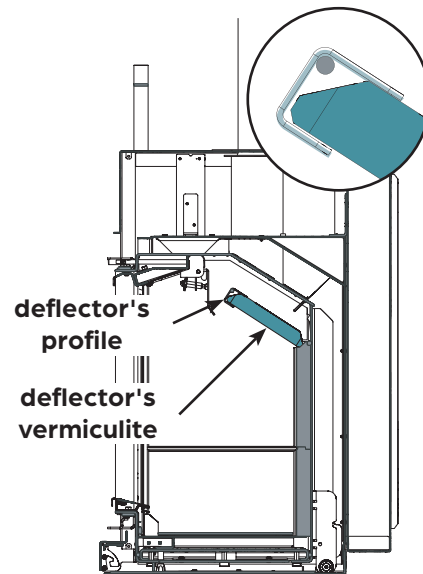

# 8

## WARRANTY

8.1	WARRANTY DETAILS .....	56
8.2	WARRANTY FORM .....	57



## 8.1 WARRANTY DETAILS



### WARRANTY COVERAGE

Stûv appliances are guaranteed against:

- manufacturing defects
- paint defects on the visible parts of the unit
- glass breakage, but only if it occurs during the first firing
- shipping-related damage if we are notified within 48 hours of delivery and the damage is noted on the carrier's bill of lading when the unit is received (website)

This warranty does not cover damage to the appliance or malfunctions due to:

- installation that does not comply with the applicable regulations or the installation instructions
- abnormal use that does not comply with the directions for use
- lack of maintenance
- an external cause, such as a flood, lightning strike, fire, etc.

The warranty is limited to replacing the parts deemed defective and does not include labour or damages.

### WARRANTY TERMS

This document must be returned to us, duly completed, within one month of the date of the dealer's invoice to the buyer.

Duration of the warranty:

- 5 years on the body of the appliance
- 1 year on refractory materials, gaskets, door mechanism, hinges and latches.

The warranty period begins on the date of the dealer's invoice to the buyer. The replacement of parts under warranty does not extend the duration of the initial warranty.

When an item is defective, it is important to quickly notify an authorized Stûv dealer. They will contact Stûv America to fill out the warranty form. They will need:

- the unit's serial number
- the date the unit was purchased
- an explanation of the defective item
- photos of the defective item

With this information, Stûv America will be able to validate whether the part is covered by the warranty and judge the relevance of changing it. The dealer will also be in charge of installing the new part.

### CERTIFICATE OF WARRANTY

This Stûv appliance has been designed to offer you maximum pleasure, comfort and safety. It has been manufactured with the utmost care using quality materials and components to provide years of trouble-free operation.

Should you notice a defect in spite of this care, we commit to rectifying the situation. However, as a user, you also have an important role to play in getting the satisfaction you expect from your Stûv.

#### We strongly recommend:

- having the unit installed by a qualified professional who can ensure that the installation of the appliance and the integrity of the chimney are in compliance with the certifications and the building code,
- carefully reading the operating and maintenance instructions,
- having the chimney swept regularly (once per heating season, for regular use) to ensure optimal operation and maximum safety.

## 8.2 WARRANTY FORM



### THE APPLIANCE

Serial no.: \_\_\_\_\_

Model: \_\_\_\_\_

Invoice date: \_\_\_\_\_

Installation date: \_\_\_\_\_

\*The serial number can be found on the marking label at the bottom of the combustion chamber. The location of the label is indicated on the first page of the *CERTIFICATION* section.

### THE INSTALLER

I, the undersigned,  
declare that the above-mentioned appliance has been installed in compliance with the existing regulations and in accordance with the technical recommendations in the installation instructions.

Date: \_\_\_\_\_

Signature: \_\_\_\_\_

Company: \_\_\_\_\_

Name: \_\_\_\_\_

Address: \_\_\_\_\_

Tel no.: \_\_\_\_\_

### THE DEALER

Company: \_\_\_\_\_

Name: \_\_\_\_\_

Address: \_\_\_\_\_

Tel no.: \_\_\_\_\_

### THE BUYER

Name: \_\_\_\_\_

Address: \_\_\_\_\_

Email: \_\_\_\_\_

Tel no.: \_\_\_\_\_

Installation address (if different): \_\_\_\_\_

### PLEASE FILL OUT THIS FORM AND SEND IT TO US VIA:

Our website: **stuvamerica.com**  
On the Warranty and Product Registration page

**Stûv America Inc.**  
34, Boulevard de l'Aéroport  
Bromont Québec J2L 1S6 Canada

Email: **info@stuvamerica.com**  
Tel.: +1-866-487-7888  
Fax: +1-514-528-9538



---

Stûv fireplaces are designed by:

Stûv sa – Belgique  
stuv.com

Rue Jules Borbouse n°4 B-5170  
Bois-de-Villers

---

And manufactured in North America by:

Stûv America inc. – Canada  
stuvamerica.com

34, Boulevard de l'Aéroport  
Bromont QC Canada J2L 1S6

1-514-396-3463 | 1-866-487-7888