

Passion for Perfection

The Arcadia is perfect for any entertainment area, with its elegant design and reliable performance. Its impressive size creates a focal point for social gatherings.

FEATURES

- 65K Stainless Steel Burner
- Natural Gas or Propane
- Lava Rocks Included
- Additional Accessories available
- Weight: 400lb | 180kg

IGNITION

- Manual Lit
- Compatible with portable propane tanks

GAS INLET PRESSURES

The installer is responsible for using the correct fuel lines and/or regulation to provide gas to the fire feature within the specified minimum gas inlet pressures.

Refer to installation manual for further information

TRAVERTINE

Drawing inspiration from classical Roman aesthetics, this unique and complex texture imbues our FOUNDATION collection with rustic depth and beauty reminiscent of ancient splendour.



WHITE WISP



GREY CLOUD

Match Light	Minimum	Maximum
Natural Gas	7.0" W.C (1.7436 Kpa)	10.0" W.C (2.4884 Kpa)
Liquid Propane	11.0" W.C (2.7399 Kpa)	13.0" W.C (3.2381 Kpa)

STANDARD MODEL

Dimensions

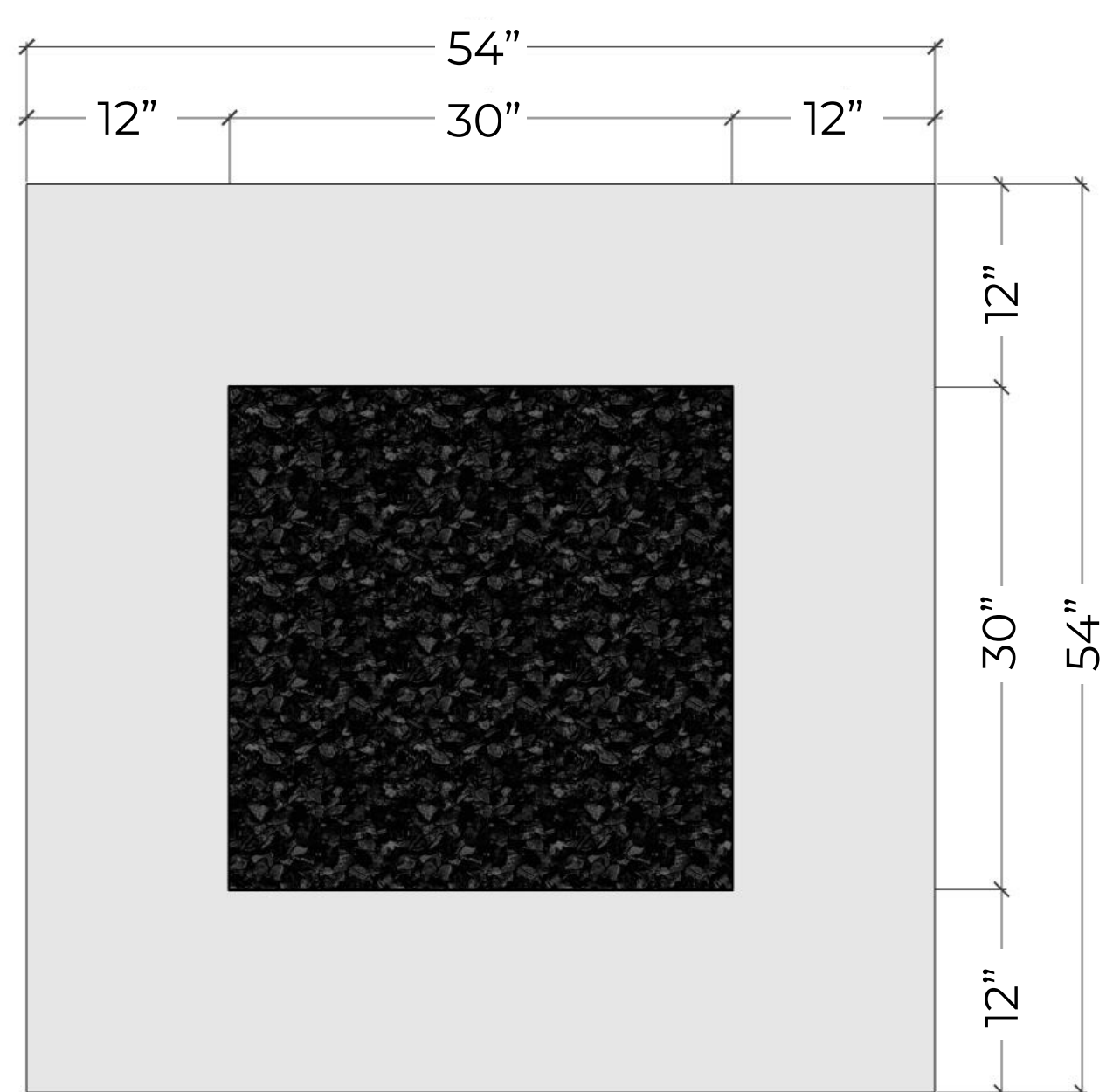
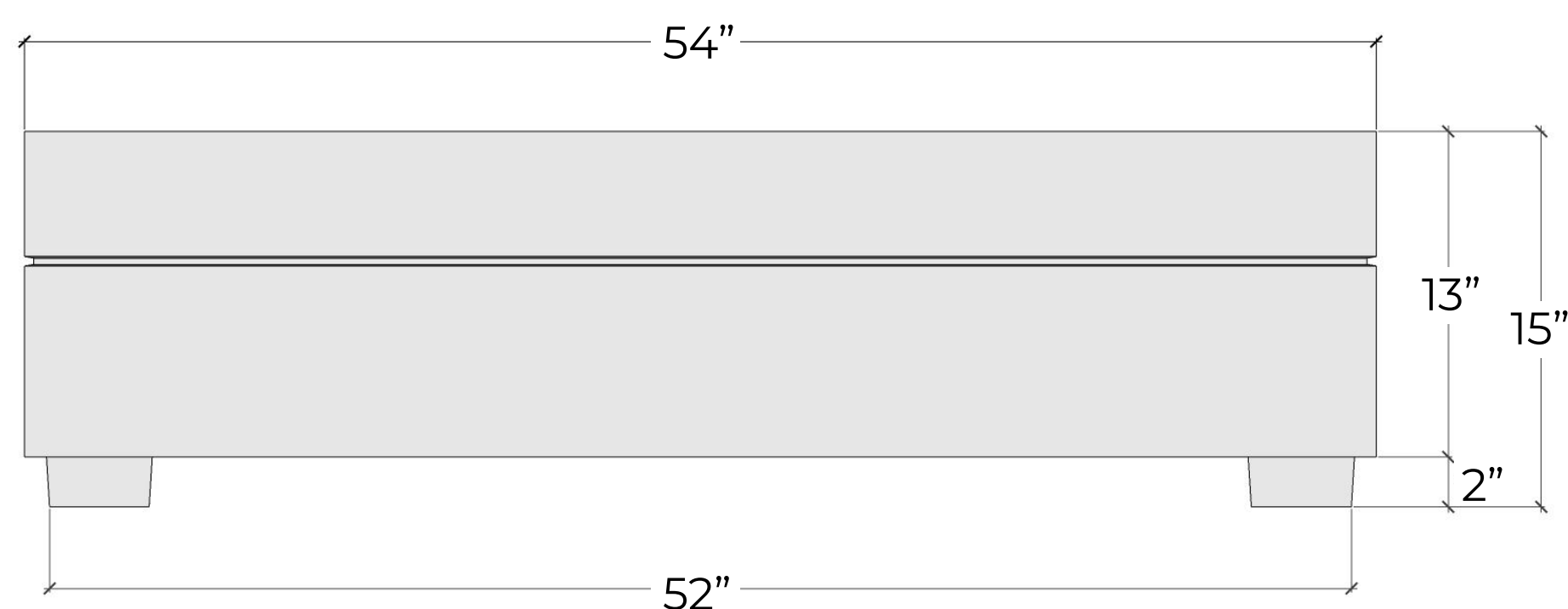
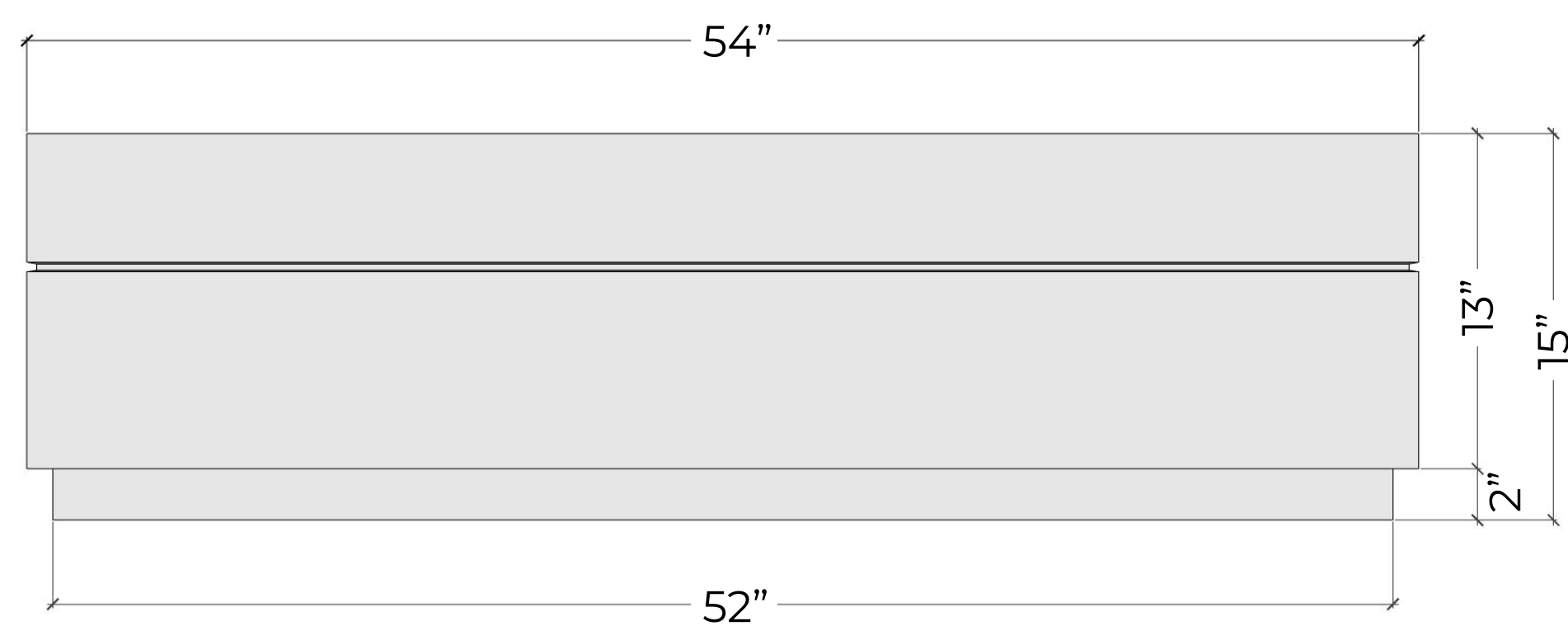

CLEARANCES

Overhead	84"
Horizontal	36"
Below	0"