



WARNING: If the information in these instructions is not followed exactly, a fire or explosion may result in causing property damage, personal injury, or loss of life.

Do not store or use gasoline or other flammable vapors or liquids in the vicinity of this or any other appliance.

If you smell gas, please:

- Do not try to light any appliance
- Do not touch any electrical switch; do not use any phone in your building.
- Immediately call your gas supplier from a neighbor's phone. Follow the gas supplier's instructions.
- If you cannot reach your gas supplier, call the fire department.

A qualified installer, service agency, or local gas supplier must perform installation and service.

DANGER



HOT GLASS WILL CAUSE BURNS.

DO NOT TOUCH GLASS UNTIL COOLED

NEVER ALLOW CHILDREN TO TOUCH GLASS

A barrier designed to reduce the risk of burns from the hot viewing glass is provided with this appliance and must be installed for the protection of children and other at-risk individuals.



Flare requires installation be performed by an NFI certified installer, or an authorized Flare Dealer Tech who has been trained to professionally install the fireplace. Installations that do not follow this instruction will not be covered by warranty or service.

NOTICE

INSTALLER: Leave this manual with the appliance.

CONSUMER: Retain this manual for future reference.

Installation and service of this appliance must be performed by qualified NFI certified technician, or a certified and trained Flare Fireplaces dealer.

Massachusetts: The piping and final gas connection must be performed by a licensed plumber or gas fitter in the state of Massachusetts. Also, see local code for carbon monoxide requirements.

Flare Fireplaces Large Installation Manual – SIT ProFlame II

[Flare Traditional Fireplace 39, 42, and 46 | Version 1.7](#)



CONTENTS

SAFETY INFORMATION AND WARNINGS 7

FLARE FIREPLACES – FRAMELESS IN EVERY WAY..... 10

 CSA CERTIFICATION 10

MANUAL MODEL LIST AND INFORMATION 11

FIREPLACE OPERATION 12

 REMOTE CONTROL – INSTRUCTIONS..... 12

 TEMPERATURE INDICATION DISPLAY 13

 TURNING THE SYSTEM ON..... 14

 FLAME HEIGHT CONTROL 15

 SMART THERMOSTAT MODE..... 16

 MANUAL THERMOSTAT MODE..... 17

 CONTINUOUS PILOT AND INTERMITTENT PILOT IGNITION (IPI AND CPI) 18

 KEY LOCK – CHILD SAFETY MODE 19

 LOW BATTERY DETECTION..... 20

 PAIRING YOUR REMOTE TO THE SIT RECEIVER..... 21

 IGNITION SEQUENCE 22

 WALL SWITCH – OPERATION 23

MEDIA PLACEMENT GUIDE AND CALCULATION GUIDE..... 24

 TRADITIONAL FIREPLACE MEDIA OPTIONS..... 25

FEATURE INSTALLATION 28

 BRICK BACK INSTALLATION..... 28

 STEP ONE 29

 STEP TWO 29

 STEP THREE 30

 STEP FOUR 31

 REFLECTIVE BLACK BACK INSTALLATION 32

 STEP ONE 32

 STEP TWO 33

 STEP THREE 33



SUMMIT LOG INSTALLATION	34
INTERNAL CERAMIC GLASS INSTALLATION (INNER GLASS)	35
STEP ONE	35
STEP TWO	36
STEP THREE	36
STEP FOUR	37
STEP FIVE	37
STEP SIX	38
INTERNAL TEMPERED GLASS INSTALLATION (MIDDLE GLASS)	39
STEP ONE	39
EXTERNAL TEMPERED GLASS INSTALLATION (OUTER GLASS)	40
STEP ONE	40
INVISIBLE MESH SAFETY SCREEN	41
STEP ONE	41
STEP TWO	42
STEP THREE	42
FIREPLACE INSTALLATION STEPS	43
ACCESSING FIREPLACE COMPONENTS	44
FIREPLACE UNCRATING	45
STEP ONE	45
STEP TWO	45
STEP THREE	46
STEP FOUR	46
GETTING FIREPLACE INTO POSITION	47
STEP ONE	47
STEP TWO	47
STEP THREE	47
RGB LED LIGHTS	48
RGB LED REMOTE	48
PAIRING YOUR RGB LED REMOTE - GEN 1 AND GEN 2	50



RGB LED REMOTE PAIRING	51
GEN 1 REMOTE PAIRING	51
GEN 1 REMOTE UNPAIRING	51
GEN 2 REMOTE PAIRING	51
RGB LIGHT VERIFICATION – PRE-INSTALL	52
VENT TERMINATION	53
FIREPLACE AND VENT PIPE SIZE	54
MINIMUM TO COMBUSTIBLES FROM VENT PIPE	54
VERTICAL TERMINATION - SINGLE	55
VERTICAL TERMINATION – DOUBLE	56
HORIZONTAL TERMINATION – DOUBLE	56
VENT TERMINATION CLEARANCES	57
SETTING UP FIREPLACE VENT RESTRICTOR	58
CHIMNEY PATH – INSTALLATION AND PLANNING	59
FLARE TRADITIONAL – 39, 42, 46 TRIPLE GLASS	60
FLARE TRADITIONAL – 39, 42, 46 SCREEN	61
POWER VENTING	62
POWER VENT SPECIFICATIONS	63
POWER VENT INTERNAL ELECTRICAL DRAWING	64
GAS INSTALLATION	65
GENERAL	65
GAS VALVE OVERVIEW	66
DE-RATING	67
ADDING REDUCER TO DERATE FIREPLACE AT ELEVATION	68
ORIFICE SIZE	69
MANUAL GAS SHUT OFF	69
LIQUID PROPANE USAGE IN A FLARE FIREPLACE	70
COMMONWEALTH OF MASSACHUSETTS	71
POWER REQUIREMENTS	73
TELEVISION MOUNTING ABOVE FIREPLACE	74



TV INSTALL – FLAT EXAMPLE	75
TV INSTALL – L TYPE E	76
TV INSTALL RECESS – 45 DEGREE ELBOW ON TOP OF THE UNIT	77
TV INSTALL FLUSH WITH MANTEL	78
CLEARANCES	79
METAL FRAMING SPECIFICATIONS	79
WOOD FRAMING SPECIFICATIONS	80
CLEARANCES SPECIFICATIONS	89
MANTEL CLEARANCES	90
MANTEL CLEARANCE TABLE AND EXAMPLE	90
CLEARANCES TO SPRINKLER	91
TRADITIONAL HEAT RELEASE OVERVIEW	92
TRADITIONAL HEAT RELEASE EXAMPLES	93
SHADOW LINE	93
DROP WALL	94
LINEAR SLOT OR LOUVERED GRATE	95
AIR INTAKE	96
EXAMPLES OF AIR INTAKES	97
TOE-KICK REVEAL	97
*SIDE VENTS	97
FLOATING HEARTH	98
LINEAR SLOT	98
TRADITIONAL FIREPLACE CLEARANCE DETAILS	99
FLATE – SIDE AND ISOMETRIC VIEW	99
L-SHAPE SIDE AND ISOMETRIC VIEW	101
HOME AUTOMATION	103
ELECTRIC AND CONTROL	104
ELECTRIC DIAGRAM	104
ELECTRIC DIAGRAM – INTERNAL PV SYSTEM	105
REPLACEMENT PARTS	106



MAINTENANCE.....	107
YEARLY SERVICE	108
APPENDIX.....	109
MAINTENANCE	109
WARRANTY POLICY.....	110



SAFETY INFORMATION AND WARNINGS

WARNING!

If the information in these instructions is not followed exactly, a fire or explosion may result causing property damage, personal injury, or loss of life. A qualified installer, service agency or the supplier must perform installation and services.

The direct-vent system appliance must be installed as an OEM installation in manufactured homes (USA only), or an aftermarket permanently located, or a mobile home, where not prohibited by local codes and must be installed in accordance with the manufacturer's instructions and the Manufactured Home Construction and Safety Standard, Title 24 CFR, Part 3280, in the United States, or the Standard for Installation in Mobile Homes, CAN/CSA Z240 MH Series, in Canada. This appliance is only for use with the type(s) of gas indicated on the rating plate. A conversion kit can be supplied with the appliance.

NEVER LEAVE CHILDREN OR ANY OTHER AT-RISK INDIVIDUAL(S) ALONE WITH THE APPLIANCE

State of California – Proposition 65 Warning : Fuels used in gas, wood-burning or oil-fired appliances, and the products of combustion of such fuels, contains chemicals known to the State of California to cause cancer, birth defects and other reproductive harm. California Health and Safety Code Section 25249.6

Due to elevated temperatures, the appliance should be located outside of traffic and away from furniture and draperies. Children and adults should be alerted to the hazards of high surface temperature and stay away to avoid burns or clothing ignition.

Young children should be carefully supervised when they are in the same room as the appliance. Toddlers, young children, and others may be susceptible to accidental contact burns. A physical barrier is recommended if there are at-risk individuals in the home or business. To restrict access to a fireplace or stove, install an adjustable safety gate to keep toddlers, young children, and other at-risk individuals out of the room and away from hot surfaces.

This appliance must be electrically wired and grounded in accordance with local codes, or in the absence of local codes, with National Electric Code ANSI/NFPA 70 – latest edition or the Canadian Electric Code CSA C22.1 A 110-120V AC circuit for this product must be protected with the ground-fault circuit-interrupter protection, in compliance with the applicable electrical codes, when it is installed in locations such as bathrooms or near sinks.



WARNING!

Proposition 65 Warning: Fuels used in gas, wood burning or oil-fired appliances, and the products of combustion of such fuels, contain chemicals known to the State of California to cause cancer, birth defects and other reproductive harm. California Health & Safety Code Sec. 25249.6. In the State of Massachusetts, only a licensed plumber and gas fitter may install this product. See Note for the Commonwealth of Massachusetts.

When an existing Category 1 heater is removed or replaced, the original venting system may no longer be sized to properly vent the attached appliances. Instructions shall also indicate effects of an improperly sized venting system (formation of condensate, leakage, spillage, etc.) and shall specify the following test procedure.



WARNING Carbon Monoxide Poisoning Hazard

Failure to follow the steps below for each appliance connected to the venting system being placed into operation could result in carbon monoxide poisoning or death. The following steps shall be followed for each appliance connected to the venting system being placed into operation, while all other appliances connected to the venting system are not in operation:

- 1) Seal any unused openings in the venting system.
- 2) Inspect the venting system for proper size and horizontal pitch, as required in the National Fuel Gas Code, ANSI Z223.1/NFPA 54 or the Natural Gas and Propane Installation Code, CSA B149.1 and these instructions. Determine that there is no blockage or restriction, leakage, corrosion, and other deficiencies which could cause an unsafe condition.
- 3) As far as practical, close all building doors and windows, and all doors between the spaces in which the appliance(s) connected to the venting system are located and other spaces of the building.
- 4) Close all fireplace dampers.
- 5) Turn on clothes dryers and any appliance not connected to the venting system. Turn on any exhaust fans, such as range hoods and bathroom exhausts, so they are operating at maximum speed. Do not operate a summer exhaust fan.



Carbon Monoxide Poisoning Hazard Continued

- 6) Follow the lighting instructions. Place the appliance being inspected into operation, and adjust the thermostat so appliance is operating continuously.
- 7) Test for spillage from draft hood equipped appliances at the draft hood relief opening after five minutes of main burner operation. Use the flame of a match or candle.
- 8) If improper venting is observed during any of these above tests, the venting system must be corrected in accordance with the National Fuel Gas Code, ANSI Z223.1/NFPA and/or Natural Gas and Propane Installation Code, CSA B149.1.
- 9) After it has been determined that each appliance connected to the venting system properly vents when evaluated as outlined above, return doors, windows, exhaust fans, fireplace dampers and any other gas-fired burning appliance to their previous conditions of use.



FLARE FIREPLACES – FRAMELESS IN EVERY WAY

Flare Fireplaces are where innovation, quality and luxury come together to form innovative ideas. By combining superior raw materials, contemporary design, creative technology, and a frameless way of thinking, we have created a full line of direct-vent fireplaces that are luxurious, simple to operate, and efficient. Our modern gas fireplaces are distinguished by their clean linear design, superior built quality, and unique features.

CSA CERTIFICATION

All our fireplaces are evaluated and have been certified to meet stringent CSA guidelines, ensuring optimum quality, safety, and efficiency, as well as been certified and evaluated to work with Natural Gas or Liquid Propane.

Certification Information: [CSA File # 263124](#)

CSA/ANSI Z21.88-2019 • CSA 2.33-2019- Vented Gas Fireplace Heaters

CSA Classes: CLASS 2901 84 / CLASS 2901 04

All fireplaces are rated for commercial and residential use.



The CSA Mark

The Canadian Standards Association (CSA) is a nonprofit association serving business, industry, government and consumers in Canada and the global marketplace. Among many other activities, CSA develops standards that enhance public safety. A Nationally Recognized Testing Laboratory, CSA is familiar with U.S. requirements. **According to OSHA regulations, the CSA-US Mark qualifies as an alternative to the UL Mark.**

Here are some areas where CSA standards are applied:

- Canadian Electrical Code, Part III-Outside Wiring
- Electrical Engineering Standards
- Electromagnetic Compatibility



MANUAL MODEL LIST AND INFORMATION

All models share the same gas valve system, remote, gas connection, and glass type, simplifying installation and operation. All warnings and instructions apply to the following models:

- Flare Traditional 39"
- Flare Traditional 42"
- Flare Traditional 46"

Flare Fireplaces should only be connected to M&G DuraVent or ICC 4x6 or 5x8 direct-vent system. Refer to the specific appliance model and size to determine vent size (Gas specification table) and chimney pathway requirements. For detailed chimney installation information please use the M&G DuraVent direct vent installation manual: <http://www.duravent.com>

For details on ICC direct vent installation, please use the ICC installation guide: <http://icc-chimney.com/en/exceldirect-support>

This product is listed to ANSI standards for "Vented Gas Fireplace Heaters" and applicable sections of "Gas Burning Heating Appliances for Manufactured Homes and Recreational Vehicles", and "Gas Fired Appliances for Use at High Altitudes".

Installation **MUST** comply with local, regional, state, and national codes and regulations. Consult insurance carrier, local building inspector, fire officials or authorities that have authority over restrictions, installation inspection and permits.

This installation must conform to local codes. In the absence of local codes, you must comply with the National Fuel Gas Code, ANSI Z223.1 -latest edition in the USA and the CAN/CGA B149 Installation Codes in Canada.

Improper installation, adjustment, alteration, service, or maintenance can cause injury or property damage. For assistance or additional information, consult a qualified service technician, service agency or your local fireplace dealer.



Flare Fireplaces requires installation be performed by an NFI certified installer, or certified Flare dealer. Installations that do not follow this instruction will not be covered or serviceable under warranty.



FIREPLACE OPERATION

Every indoor Flare Fireplace ship with a remote control and wall switch to operate the fireplace and its features. **These two items do not work in parallel with one another, so if you turn the fireplace on with one it must also be turned off with that same option.** *Home automation is also available by removing the included wall switch and replacing it with a low voltage close-contact relay which can be tied into a new or existing home automation system or smart device.

* Flare Fireplaces does not recommend the use of home automation with our fireplaces. Only operate the fireplace when you can be in the same room as the high-powered gas appliance.

[Click here for printable Remote Operation Guide](#)

REMOTE CONTROL – INSTRUCTIONS

The SIT ProFlame II system ships with an easy-to-use four-button remote control. It requires three AAA batteries and has a 0-50°C ambient temperature rating with a 315MHz radio frequency.

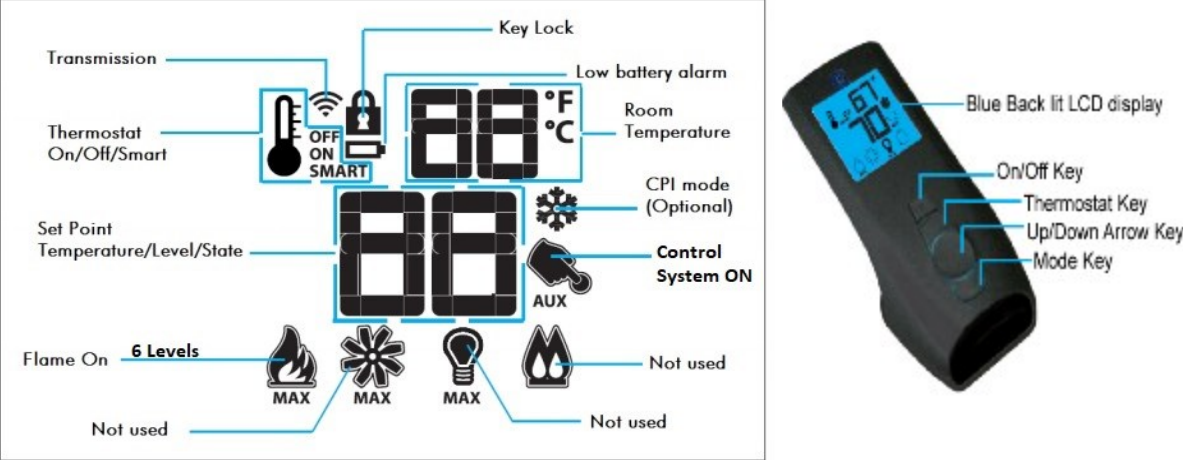

TEMPERATURE INDICATION DISPLAY

When the system is turned off the LCD screen will display the current room temperature in Fahrenheit (°F) or in Celsius (°C.).

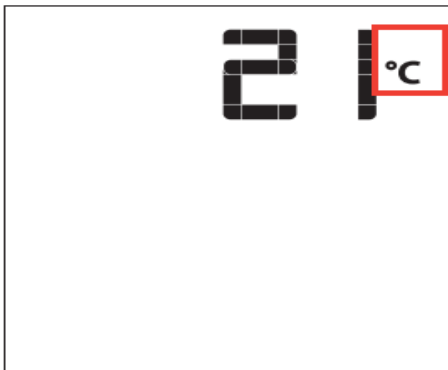

To change from in Fahrenheit (°F) to Celsius (°C.), or vice versa, press the **“Thermostat”** key and the **“Mode”** key at the same time.



TURNING THE SYSTEM ON

When in “On” mode the remote LCD will show the room temperature icon, and any other modes currently turned on by default.



To turn “On” press the On/Off remote button. The remote LCD will then show other icons. At that time, the module will activate the appliance and a single beep from the receiver will confirm command from the remote.



FLAME HEIGHT CONTROL

ProFlame II has 6 levels of modulation. When the system is On the flame level will be at the maximum level. Once adjusted the remote LCD will show a series of 6 steps going down, or up, depending on adjustments being made.

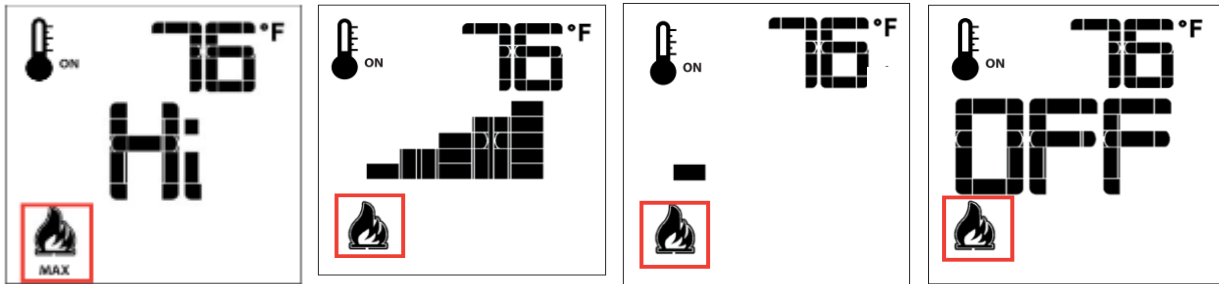

By pressing the “Down” key once it will reduce the flame height by one step. Continued pressing of the down arrow will result in the unit turning off. To return to normal fireplace operation use the “Up” key to increase the flame height to high. If the “Up” has been pressed while the system is ON, but the flame is OFF the flame will come ON in the high position.



SMART THERMOSTAT MODE

The smart thermostat mode will adjust the flame height depending on the set temperature that has been set by the user. When the room temperature gets close to the set temperature the smart thermostat function will modulate the flame down.

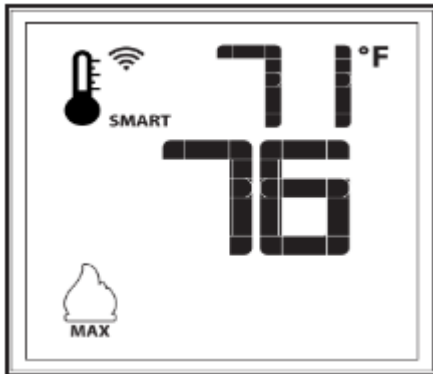

To activate the smart thermostat function, press the **“Thermostat”** key while the appliance is on until the word SMART appears beside the icon of the thermostat. To adjust the set temperature, press the **“Up”** or **“Down”** arrow keys until the desired temperature is displayed on the LCD.



MANUAL THERMOSTAT MODE

The Remote control can operate as a room thermostat. The thermostat can be set to a desired temperature to control the room temperature. The thermostat icon on the LCD screen will display the thermostat status is ON. The user can then set a suitable temperature for the space.

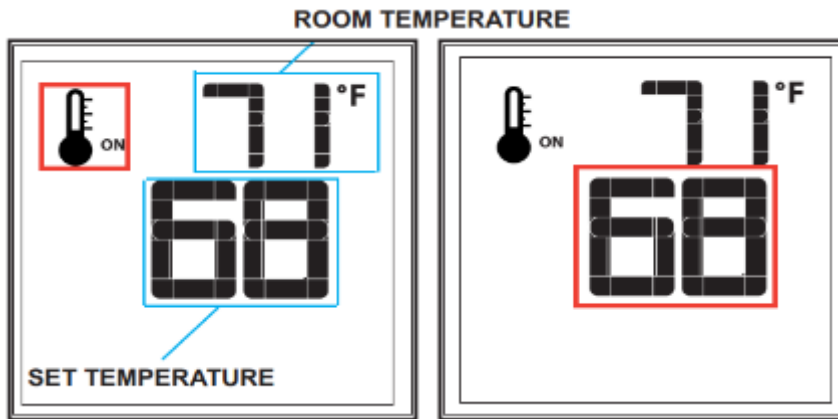

To activate this option, press the “Thermostat” key. To adjust the desired temperature, use the “Up” or “Down” until the desired temperature is displayed on the remote LCD screen.

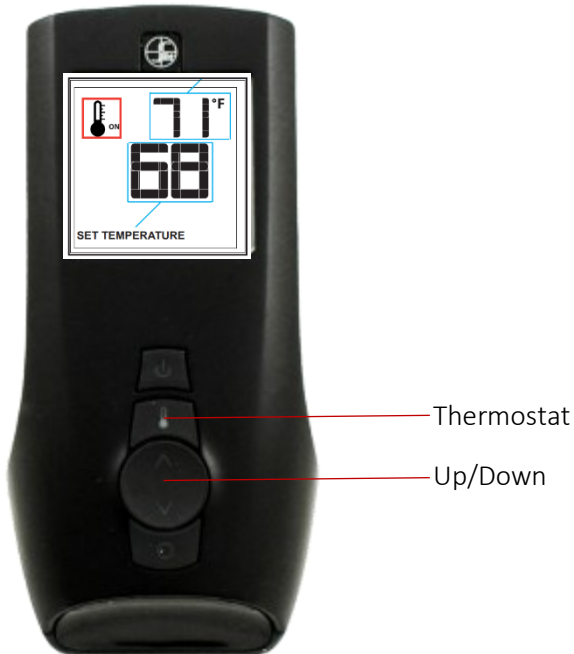

CONTINUOUS PILOT AND INTERMITTENT PILOT IGNITION (IPI AND CPI)

By default, the Flare Fireplace is setup for IPI operation, but this can be changed to CPI **on screen units only**.

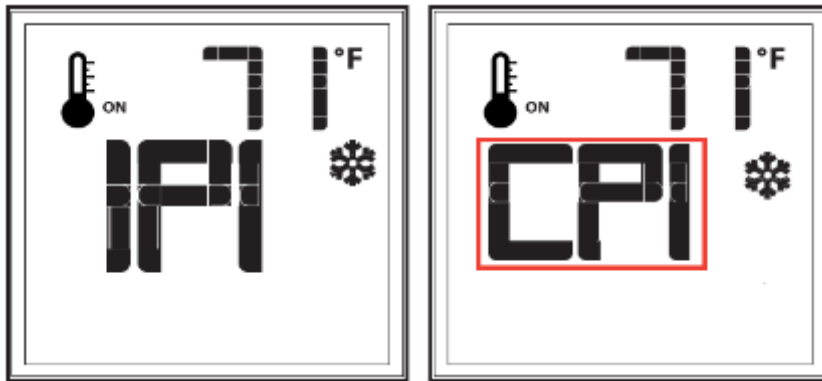

When the system is Off pressing the “**Mode**” key to index to CPI mode icon. Pressing the “**Up**” arrow will select the **CPI** mode (*but it is still not activated. See instructions at link above*)



[For detailed instructions on how to change from IPI to CPI please click here.](#)

KEY LOCK – CHILD SAFETY MODE

To avoid unsupervised operation of the remote control this feature has been created. A lock icon will appear on the LCD screen.

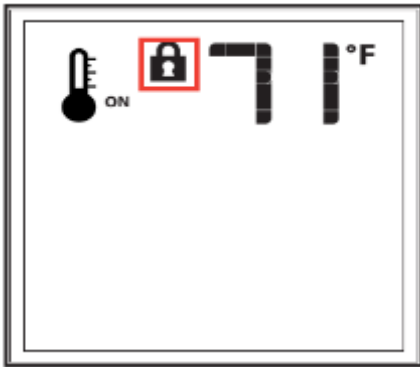

To activate this feature, press the **“Mode”** and **“Up”** at the same time. A lock icon will appear on the LCD screen. To deactivate this feature, press **“Mode”** and **“Up”** at the same time.





LOW BATTERY DETECTION

The lifespan of your remotes three AAA batteries varies based on remote and fireplace operation. When the remote battery is low an empty battery icon will appear on the LCD Screen

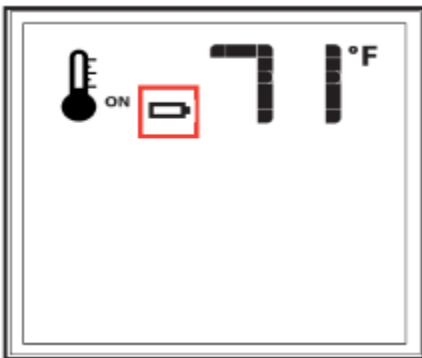

WARNING

Do not use a screwdriver or other metallic object to remove the batteries from the battery box! This could cause a short circuit to the system.

PAIRING YOUR REMOTE TO THE SIT RECEIVER

Your remote will come paired with the fireplace receiver to allow for operation out of the box. In the event of a remote or receiver replacement, or power failure, use the following procedure to pair the remote with the receiver. First, install 3 AAA batteries in the remote battery bay located on the remote back. Next, press the SW1 button on the module see the following figure, the module will beep 3 times to indicate that it is ready to synchronize with the remote. Finally, press the ON/OFF button in the remote, the module will beep 4 times to indicate that the remote and the module are synchronized to each other.

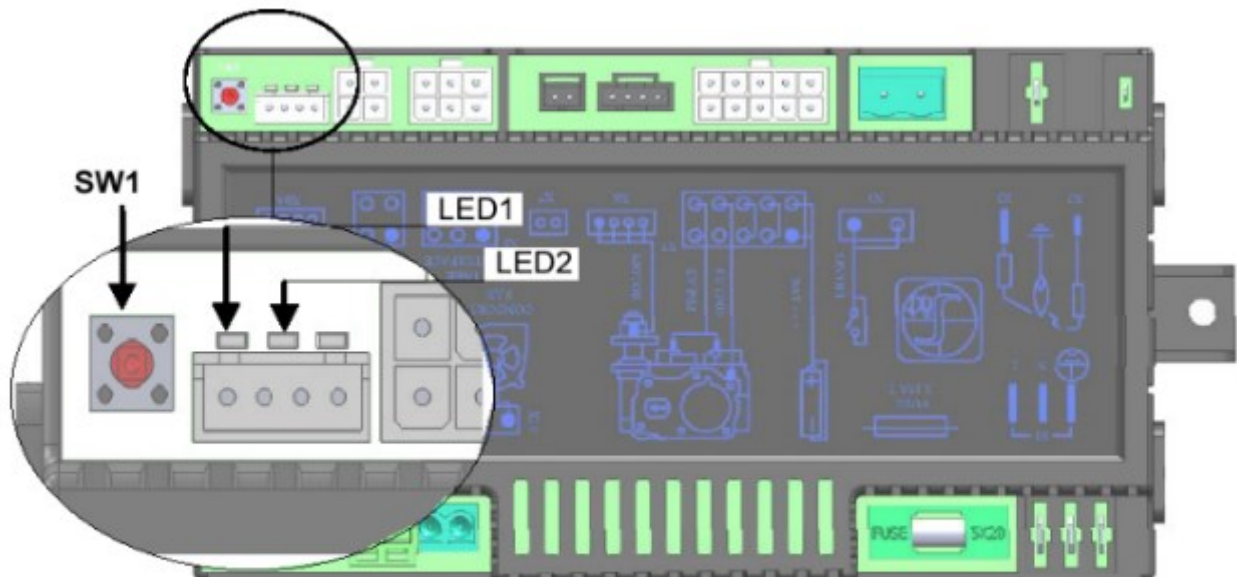

SW1 = Programing Button



IGNITION SEQUENCE

Starting from Off, press the remote power button. Four seconds after it is pushed the SIT module will send a spark to the pilot hood, and spark for 60 seconds. If there is no flame ignition during the first ignition sequence, the SIT module will stop sparking for approximately 35 seconds and then begin sparking again. The second attempt will spark for 60 seconds. If there is no positive ignition after the second sequence the SIT module will go into a Lock Out and the LED Indicator Light will blink three times in intervals until the system is reset.

Reset Using the Transmitter ON/OFF power button: Turn the system off by pressing the remote power button. After approximately 2 seconds press it again

Low Battery Condition (<4V) Remote Control: Battery icon will appear on LCD remote control display. Replace batteries.

Low Battery Condition (<4V) Battery Backup: Red LED Indicator will blink (1) time in intervals. Low double-beep emitted from SIT control module when it receives an ON/OFF command from the remote control. Replace Batteries.

Pilot Flame Error Condition: Red LED Indicator will blink (2) times in intervals. Contact your dealer if this occurs.

System Lock Out Condition: Red LED Indicator will blink (3) times in intervals. Make sure gas is turned on and sensor is not shorted. Follow **Reset Using the Transmitter ON/OFF power button** instructions above.



WALL SWITCH – OPERATION

The SIT ProFlame II system ships with an easy-to-use wall switch which operates the On/Off functionality only. It can be used in the event the remote control isn't nearby or has no battery charge. The wall switch comes connected to the X8 port on the SIT receiver.

NOTICE

When used with cool glass, power vented, and summer kit systems, the wall switch must be connected to operate the relay necessary to turn the secondary fan system on, verify power, and allow ignition. Also, the wall switch does not work together with the remote. If you turn on the unit with the wall switch, it must also be turned off using the wall switch to prevent syncing and ignition issues with your system.





MEDIA PLACEMENT GUIDE AND CALCULATION GUIDE

Every Flare fireplace can be set up with approved glass, stone, or wood media. Quantities are determined by the size of the fireplace and type of media chosen within that fireplace. Mixing of media types (i.e., glass and stones together) is acceptable if the quantities are adjusted to prevent overwhelming the burner and gas flow. To achieve a balance between the ideal appearance and operation the following guidelines have been set to create an optimum overall presentation. Stepping outside of these recommendations will lead to excess sooting, uneven gas flow, and degraded flame presentation.

[Click here for Media Placement Guide](#)

NOTICE FOR ALL MEDIA TYPES

- Maintain a 1" clearance on all sides of the pilot cover to prevent continuity issues with ignition.
- Avoid installing media in quantities that exceed the recommendations in the media calculation guide.
- Keep all media within the fireplace burner tray.
- Do not place media between the inner glass and external safety barrier.
- Media cannot be smaller than ¼"

WARNING

CHOKING HAZARD! Ensure that the fireplace area is clear of fire glass particles as these could be ingested by small children. Vacuum area after installation.

TRADITIONAL FIREPLACE MEDIA OPTIONS

The following outlines the media options available for installation within the Flare Traditional Fireplaces.

CERAMIC PEBBLES

- Matte Black Pebbles
- White Pebbles
- Earth Mixed Pebbles



EMBERS

- Tan Embers
- Black Embers



GLASS MEDIA

- Raindrop Diamonds
- Black Moon Glass



CERAMIC LOGS

- Ceramic Logs
- White Logs
- Ceramic Branches
- Small Birch Branches



SUMMIT SERIES BIRCH LOGS

The logs within the Traditional fireplace can be slightly altered depending on how you want the interior to appear. The largest center log is not interchangeable, but the outer logs may be swapped from left to right depending on preference.

Left Side Set



Right Side Set



WARNING

CHOKING HAZARD! Ensure that the fireplace area is clear of fire glass particles as these could be ingested by small children. Vacuum area after installation.



FEATURE INSTALLATION

BRICK BACK INSTALLATION

The Flare Fireplace may be ordered with a ceramic brick back. The ceramic bricks are shipped outside the unit, inside a sleeve with the other glass panes. Follow the instructions below to mount them in the Flare Traditional fireplace.



STEP ONE

Using a PH3 bit remove the screws around the perimeter of the burner tray, then perimeter of the burner, and finally log-burner cover screws to release the burner tray completely.



STEP TWO

Position all of the back and side brick panels into their lower channel and gently push against the fireplace back to stand them erect and against the inner fireplace walls.



STEP THREE

Gently pull the already installed top brackets to allow for the brick interior(s) to slide behind, resting in the lower channel provided after removing the burner tray. **Do not tighten or remove screws.**

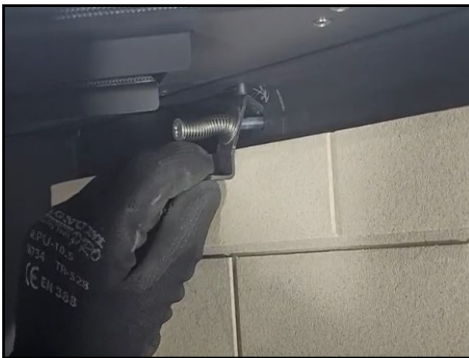
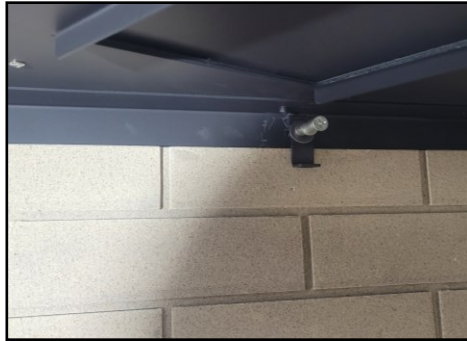

WARNING!

DO NOT OVERTIGHTEN THE PANEL FASTNERS OR GLASS/BRICK WILL BREAK

STEP FOUR

Reinstall your burner tray to finalize the interior panel installation.





REFLECTIVE BLACK BACK INSTALLATION

The Flare Fireplace can be ordered with a ceramic reflective black back. The reflective black back is shipped outside the unit, inside a sleeve with the other glass panes. It should be mounted at the back of the fireplace, placed in the gap between the fire bed and held by the top mounting brackets.

STEP ONE

Using a PH3 bit remove the screws around your burner tray to release it.



STEP TWO

Using suction cup(s) safely position your reflective black back under the upper securing clip, gently pushing up and leaning the bottom of the panel in towards the back of the fireplace, finally resting within the lower glass channel. The sides must be first lowered into the channel between the fireplace walls and burner tray, then tilted back against the back of the fireplace walls. Finally, pull the interior top brackets over the glass to secure it in place.



STEP THREE

Reinstall your burner tray to finalize the interior panel installation.

WARNING!

DO NOT OVERTIGHTEN THE PANEL FASTNERS OR GLASS/BRICK WILL BREAK

SUMMIT LOG INSTALLATION

All Traditional fireplaces share the same burner-tray base. To install the logs, gently remove from packaging and insert base of the log into the burner tube protruding from burner tray. Please remember the largest log is your center log and is always placed in the back of the tray and centered, behind the main left and right log.

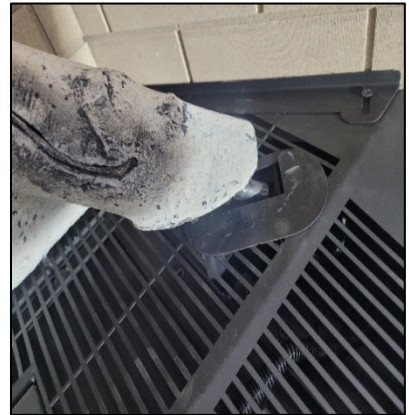

INTERNAL CERAMIC GLASS INSTALLATION (INNER GLASS)

Follow the procedures below to install the internal ceramic glass used to keep the closed combustion nature of the fireplace intact. ([Installation Video](#))



WARNING

Turn off the fireplace and wait for the glass to cool before removing after installation. Ceramic glass is extremely fragile and should be managed with care.

WARNING

Do not operate the fireplace with the glass removed, cracked, or broken. Replacement panel(s) should be done by a licensed or qualified service technician.

STEP ONE

Remove the left, right, and bottom filler pieces and place all components in secure location to prevent damage



STEP TWO

Locate and loosen the screws found on the lower frame of the fireplace using a powered drill. These will loosen the bottom glass holder which can be removed and set aside to prevent any damage.



STEP THREE

Locate and loosen the hand screws on the right and left, within the frame of the fireplace. These will loosen the trims which can be removed and set aside to prevent any damage.



STEP FOUR

Locate and loosen hand screws at the top of the fireplace, within the frame. These will loosen the top butterfly trim which stays in place but acts as a hinge pressing your glass against the fireplace frame.



STEP FIVE

Slowly and carefully place the top edge of the ceramic glass behind the upper trim, lifting into place, then slowly slide the lower edge of the glass toward the fireplace and gently set the lower glass edge on the flange as shown in the pictures below.

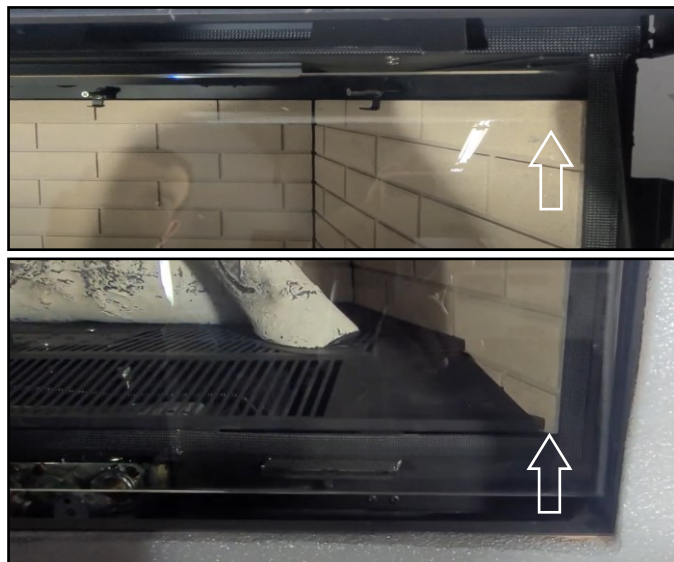

STEP SIX

Reinstall the bottom, left, and right trims to secure the glass in position. Tighten the hand screws on your top butterfly trim. Then using a power drill tighten the three screws found on the bottom glass holder as shown in the image below. Then reinsert your magnetic fillers to finish between the second layer of glass and exterior safety barrier.



NOTICE

If installing a safety screen instead of cool glass, please remember to rotate your screen clamps around and up into position before installing your bottom filler piece.



INTERNAL TEMPERED GLASS INSTALLATION (MIDDLE GLASS)

Follow the procedures below to install the internal ceramic glass used to keep the closed combustion nature of the fireplace intact.

WARNING

Turn off the fireplace and wait for the glass to cool before removing after installation. Ceramic glass is extremely fragile and should be managed with care.

WARNING

Do not operate the fireplace with the glass removed, cracked, or broken. Replacement panel(s) should be done by a licensed or qualified service technician.

STEP ONE

Attach glass suction cups to the glass. Place the left edge of glass in front of the inner-left butterfly trim and push in from right side towards left inner edge of the fireplace frame. Then tilt the right side into its channel gently placing the glass into position within its frame. No additional tools or bolts are required.

Please note this glass panel is installed from left to right.

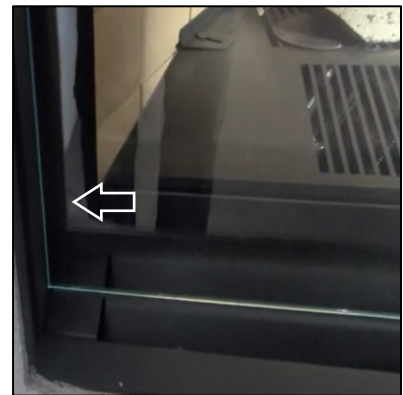

EXTERNAL TEMPERED GLASS INSTALLATION (OUTER GLASS)

STEP ONE

Attach glass suction cups to the glass. Place the right edge of glass in front of the inner-right butterfly trim and push in from left side towards right inner edge of the fireplace frame. Then tilt the left side into its channel gently placing the glass into position within its frame. No additional tools or bolts are required.

Please note this glass panel is installed from left to right.





INVISIBLE MESH SAFETY SCREEN

Follow the instructions below for quick and easy safety screen installation for each of the Flare Traditional 39, 42, and 46 fireplaces, without the need for any tools. The safety screen may ship separately from the appliance.

WARNING

This barrier is designed to reduce the risk of burns from the hot viewing window glass and is provided with this appliance. It must remain installed for the protection of children and other at-risk individuals.

STEP ONE

Locate and rotate the two upper and lower screen clamps into position, readying them for screen installation.

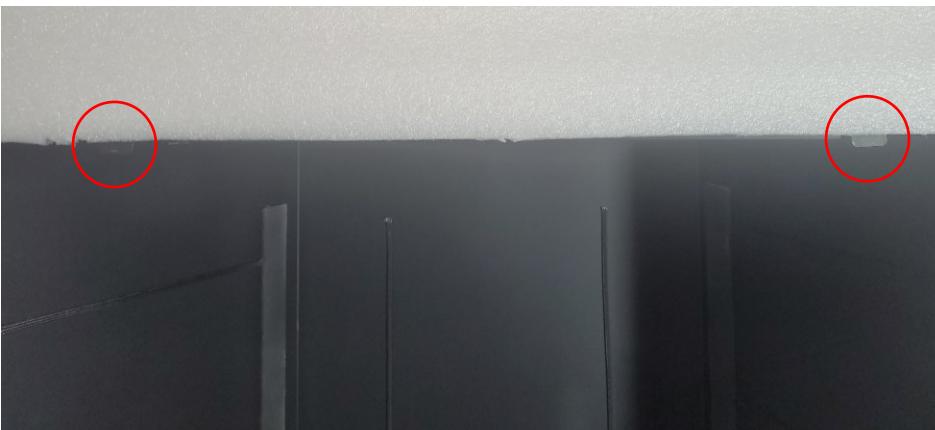

STEP TWO

Rotate bottom, left, and right mesh screen clamps using your hand

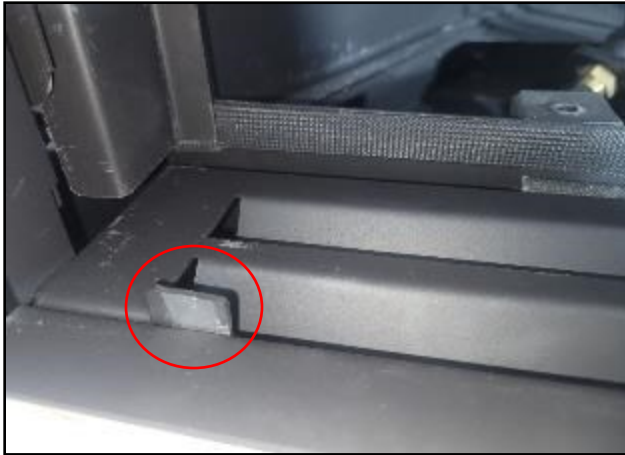

STEP THREE

Press the upper left edge of screen against the front of the screen clamps, and once the left side is inserted gently slide towards the left to allow clearance for the right side of the screen to be inserted into its guide channel, securing in place for operation.





FIREPLACE INSTALLATION STEPS

For a more detailed digital list with links for reference please use our [Jobsite Checklist](#). The following offers an overview but doesn't supersede all other tools or the installation manual as a whole when it comes to a successful installation.

WARNING

Prior to starting the installation, make sure you read and understand all the **WARNING** information in the manual. **Do not start the installation if you are unclear about any of the installation related subjects**

1. Follow this manual's **Chimney Planning and Installation Guide** for further details.
 - a. **NOTE:** Make sure the venting requirements are supported by the Flare **Chimney Planning and Installation Guide** before proceeding.
2. Follow all clearance requirements to combustible and non-combustible materials
3. Work with a licensed plumber to determine gas supply piping size and length requirements.
4. Verify the use of either Natural Gas or Liquid Propane by examining the fireplace rating plate.
5. Verify the electrical requirements have been met as outlined within this installation manual.
6. Verify all framing and finishing details align with installation manual requirements.
7. Unpack the fireplace and position inside the provided fireplace cavity.
8. Validate the RGB LED light system is connected based on your customers preference of operation, and fully operational before the fireplace is finished.
9. Attach the fireplace to the back or side wall using included top stand-off brackets.
10. On Cool Glass equipped fireplaces remove the locking screws and discard.
11. Adjust your fireplace vent restrictor based on the vent run and the Flare **Chimney Planning and Installation Guide**. Log Restrictor Setting Here (1-6): _____
12. Connect fireplace to venting system
13. Connect gas line to fireplace and verify inlet pressure aligns with requirements for the gas type being used. (*Natural Gas 7"-8" WC, Liquid Propane 10"-11" WC*): _____
 - a. If installed at an elevation above 2,000' above sea-level equipped with proper derating kit.
14. Connect fireplace to power
15. Install logs, media, inner glass panels and safety barrier [Click here for Media Placement Guide](#)
16. Test fire to validate pressures, ignition system, flame presentation, and fireplaces features.

WARNING

Read all the instructions before starting the installation. Follow these instructions carefully during the installation to ensure maximum safety and benefit. Follow the Steps above to insure proper installation of the Gas appliance. **WARNING!** Risk of Fire or Explosion! Damaged parts could impair safe operation. DO NOT install damaged, incomplete or substitute components.



ACCESSING FIREPLACE COMPONENTS

The traditional fireplace features a built-in gas valve and receiver module located behind the safety barrier and under the horizontal filler piece, eliminating the need for an access panel and simplifying servicing. For maintenance, simply remove the outer safety barrier and the lower horizontal filler piece to access these components. This allows for easy verification of gas pressure and remote-control synchronization."

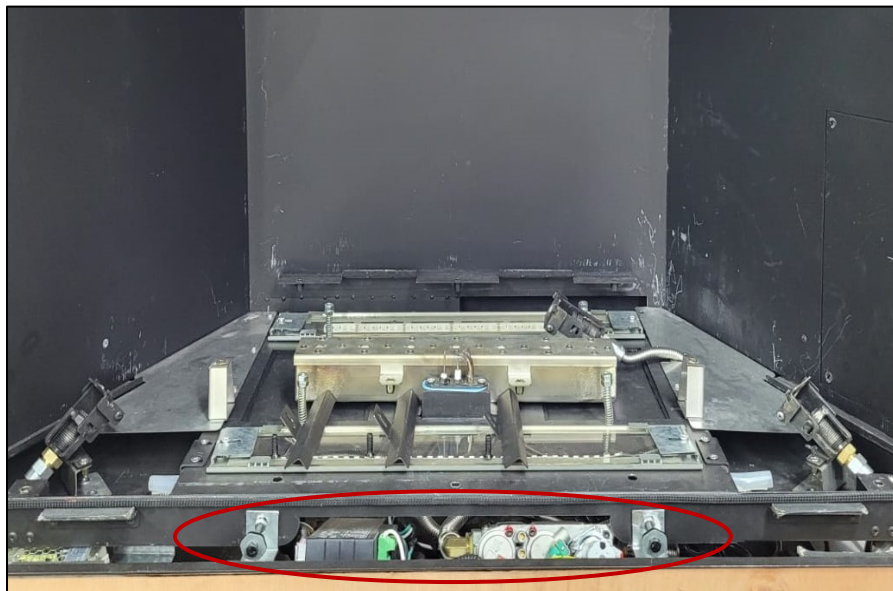

NOTICE

Items like your RGB controller and transformer are placed on the far-right side of the fireplace inside a large 10x10 access door. These components, as well as the triple glass control board, can be serviced by going through the fireplace and removing the burner tray



FIREPLACE UNCRATING

Use the following steps to properly uncrate your Flare Fireplace.

STEP ONE

Check your packing slip to confirm you have received the proper fireplace and components.



STEP TWO

Identify any obvious or hidden damage. If damage exists, mark it clearly on the Bill of Lading and contact Flare Fireplaces immediately at **1 (866) 639-1590**



STEP THREE

Remove the top, front, and back wood panels from your crate exposing the glass crate and wrapped fireplace.



STEP FOUR

Remove all the accessories and place them in a safe location to prevent damage before the first fire up. Things like media, spare parts, the glass crate can all be left in a separate safe space until you need them. This will eliminate issues with the items being lost or damaged onsite.



GETTING FIREPLACE INTO POSITION

Once the fireplace crate has been dismantled and all unnecessary items have been stored safely it's time to position the fireplace near its cavity and secure the unit in place.

STEP ONE

Keeping the unit on its pallet wheel it over to the cavity at the site location.



STEP TWO

Verify the proper clearances and materials are being used in the cavity before sliding into position. The requirements are different for each fireplace offered. Verify using the framing guides for the fireplace being installed.

[Traditional Wood Framing](#)

[Traditional Metal Framing](#)

STEP THREE

Attach the fireplace stand-off brackets to the back wall or framing on left and right side. Making sure they are only being attached to non-combustible materials.





RGB LED LIGHTS

The Traditional fireplace is shipped with multi-color interior RGB LED lighting. The lights allow the flames to be viewed across a bed of illuminated crushed glass, or any other approved direct vent media option.

RGB LED REMOTE

The multicolored option is controlled by a remote for the color selection. Once the color has been selected by the operator, the LED memory will remember that color for the next time the unit is turned on. The Flare high-performance RGB LED touch remote controller adopts the most advanced PWM control technology. This remote controls all RGB LED products with 4 lines of circuits (COMMON ANODE), offering 64 thousand colors & 20 automatic changing modes to choose from. The RBG strips require a 24V DC power adapter.

REMOTE	MATERIAL	110x52x20mm
	POWER	AAA Battery *2pcs
	MATERIAL	ABS
	FABRICATION PROCESSING	Multicolor Printing & UV Varnish
	SIZE	85x45x23mm
CONTROLLER	WORKING VOLTAGE	DC12V~24V
	CONTROL WAY	RGB 3 CHANNELS
	MAX LOAD PER CHANNEL	6A
	OUTPUT CONNECTION	COMMON ANODE
	TELECONTROL DISTANCE	30 METERS
	PROGRAMS	20 KINDS



NUMBER	MODE	BRIGHTNESS STATE	SPEED STATE
1	STATIC WHITE	ADJUSTABLE	UNADJUSTABLE
2	WHITE COLOR GRADUAL CHANGES	ADJUSTABLE	ADJUSTABLE
3	ALL COLORS GRADUAL CHANGES	ADJUSTABLE	ADJUSTABLE
4	RED/GREEN/BLUE 3 COLORS GRADUAL CHANGE	ADJUSTABLE	ADJUSTABLE
5	7 COLORS JUMP TO CHANGE	ADJUSTABLE	ADJUSTABLE
6	3 COLORS JUMP TO CHANGE	ADJUSTABLE	ADJUSTABLE
7	RED/GREEN JUMPS TO CHANGE	ADJUSTABLE	ADJUSTABLE
8	REB/BLUE JUMPS TO CHANGE	ADJUSTABLE	ADJUSTABLE
9	BLUE/GREEN JUMPS TO CHANGE	ADJUSTABLE	ADJUSTABLE
10	WHITE COLOR FREQUENTLY BLINKS	ADJUSTABLE	ADJUSTABLE
11	WHITE COLOR GLITTERS	ADJUSTABLE	ADJUSTABLE
12	RED COLOR FREQUENTLY BLINKS	ADJUSTABLE	ADJUSTABLE
13	RED COLOR GLITTERS	ADJUSTABLE	ADJUSTABLE
14	GREEN COLOR FREQUENTLY BLINKS	ADJUSTABLE	ADJUSTABLE
15	GREEN COLOR GLITTERS	ADJUSTABLE	ADJUSTABLE
16	BLUE COLOR FREQUENTLY BLINKS	ADJUSTABLE	ADJUSTABLE
17	BLUE COLOR GLITTERS	ADJUSTABLE	ADJUSTABLE
18	YELLOW COLOR FREQUENTLY BLINKS	ADJUSTABLE	ADJUSTABLE
19	YELLOW COLOR GLITTERS	ADJUSTABLE	ADJUSTABLE
20	CIRCULATION MODE		

PAIRING YOUR RGB LED REMOTE - GEN 1 AND GEN 2

Use the following instructions to pair your RGB LED remote to your RGB LED Controller in the event the communication between these two items is not functioning

GEN 1 – No arrow on remote back

[Remote Sync Video](#)



GEN 2 – With arrow on remote back

[Remote Sync Video](#)



RGB LED REMOTE PAIRING

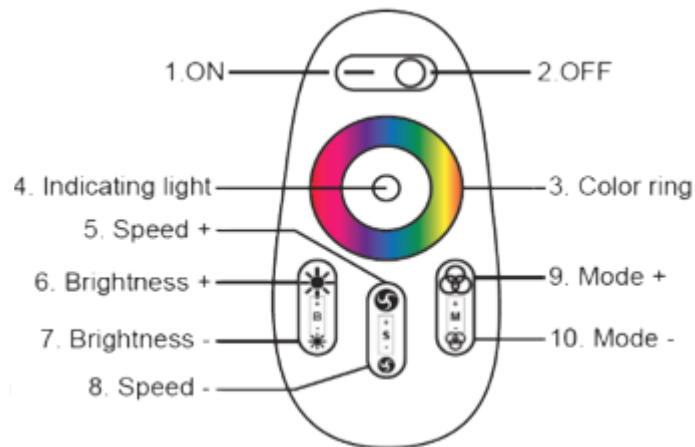

GEN 1 REMOTE PAIRING

Confirm your components are correctly connected. Remove power to the LED system, then after a short 5 second wait, reconnect power and press the #5 button the moment you see your LED lights in the firebox illuminate. If successful, your LED lights will flash twice.

GEN 1 REMOTE UNPAIRING

Confirm your components are correctly connected. Remove power to the LED system, then after a short 5 second wait, reconnect power and press the #5 button the moment you see your LED lights in the firebox illuminate. If successful, your LED lights will flash twice.

GEN 2 REMOTE PAIRING

Confirm your components are correctly connected. Remove power to the LED system, then after a short 5 second wait, reconnect power and press the #1 and #10 buttons simultaneously the moment you see your LED lights in the firebox illuminate. If successful, your LED lights will flash twice.

***GEN 2 Remotes have no unpairing process**

RGB LIGHT VERIFICATION – PRE-INSTALL

It is best if LED lights are connected and evaluated during the initial stages of installation to allow easy access to the components (before the wall finishing material is done).

Evaluating the LED light requires a 110V power source.

Testing/Installation steps:

1. Remove all LED components from the shipping bag.
2. Components are pre-connected prior to shipping. Connect LED connectors (points A) to the fireplace using the quick-connect connectors.
3. Connect LED Controller to the LED power supply (point B)
4. Connect LED Power supply to LAMP port on the SIT receiver (point C). Using the SIT Fireplace remote, scroll to the LAMP setting and turn it ON. Use the LED remote to turn the LED on the LED system. Once ON, ensure the LED responds by pressing the color wheel. If it does not, follow the instructions below.

Once testing is done, connect the LED power adapter to final power source (Point C).

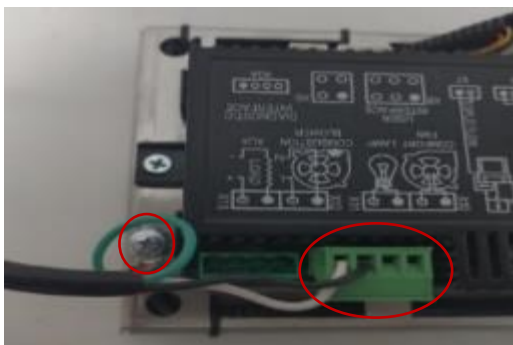
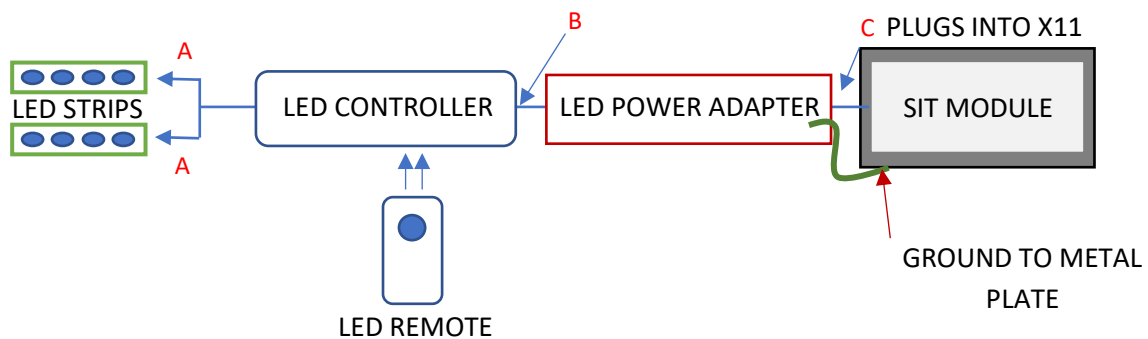



VENT TERMINATION

When passing through combustible walls and ceilings, framing will depend on the type of vent installation - horizontal or vertical. Ensure that insulation is kept clear of the vent pipe using either a wall thimble or an attic insulation shield. Follow the installation instructions supplied with the individual venting components.

These instructions should be used as a guideline and do not supersede local codes in any way. Install venting according to local codes, these instructions, the current National Fuel Gas Code (ANSI-Z223.1) in the USA or the current standards of CAN/CSA-B149.1 in Canada.

Approved Pipe - This appliance is approved for use with M&G DuraVent venting and ICC. DO NOT mix pipe, fittings or joining methods from different manufacturers.

For detailed **DuraVent** chimney installation information please use the M&G DuraVent direct vent installation manual: <http://www.duravent.com>

For detailed **ICC** chimney installation information please use the ICC direct vent installation manual: <http://icc-chimney.com/en/exceldirect>

Instructions

- Where a vent pipe passes through a floor or ceiling, a ceiling firestop **MUST** be used to retain insulation and maintain proper clearances. Use roof support brackets where needed.
- Install the first section of vent pipe into the collar on top of the fireplace.
- Connections between each vent system component must be tightly joined and secured. Follow the vent manufacturer's instructions for information on how to seal and secure vent and vent connections.
- Horizontal runs of vent pipe must be supported to prevent any downward sags. Horizontal pipe sections should be supported at least every 4 feet. Wall Straps can be used for this purpose.
- When installing the vent pipe, make sure that the vent pipe is supported by the structural/frame surrounding and not by fireplace.

Follow the vent manufacturer's instructions for information on how to install, seal, and secure vent and vent connections. Do not pack insulation around the vent pipe to prevent overheating. Always maintain specified clearances around venting and firestop systems. Install wall shield and ceiling firestops as specified.



FIREPLACE AND VENT PIPE SIZE

FIREPLACE	VENT PIPE SIZE
Flare Traditional 39"	5x8
Flare Traditional 42"	5x8
Flare Traditional 46"	5x8

MINIMUM TO COMBUSTIBLES FROM VENT PIPE

- HORIZONTAL VENT CLEARANCES:** A minimum clearance of **3 inches** (76mm) to the top and **1 inch** (51mm) to the sides and bottom of the vent pipe on all horizontal runs to combustibles is required.
 - Horizontal vents must be level or have a 1/4-inch rise for every 1-foot run towards the termination.
- VERTICAL VENT CLEARANCES:** A minimum of **1 inch** (25mm) all around the vent pipe on all vertical runs to combustibles is required except for clearances in appliance enclosures.
- When penetrating through combustible walls and ceilings, frame a minimum of 10.5" x 10.5" opening and ensure insulation is kept clear of the vent pipe using either a wall thimble or an attic insulation shield. Use the following DuraVent framing cutout table based on your selected part.

DIRECTVENT PRO CUTOUT DIMENSIONS		
STOCK NUMBER	DESCRIPTION	SIZE
46DVA-WT	Wall Thimble	10" x 10"
46DVA-WTS	Wall Thimble (Small)	9" x 9"
46DVA-WTU	Wall Thimble Universal	9" x 9"
46DVA-CS	Ceiling Support	10-3/4" x 10-3/4"
46DVA-FS	Fire Stop	9" x 9"
46DVA-WFS	Wall Fire Stop	10" x 10"
46DVA-VSS	Vinyl Siding Standoff	17" x 17"
46DVA-CF	Counter Flashing (Assembled)	13-1/2" x 13-1/2"
46DVA-CFK	Counter Flashing (4pc Kit)	13-1/2" x 13-1/2"
46DVA-CFKS	Counter Flashing (Small Kit)	10-1/2" x 10-1/2"
46DVA-VSK	Vinyl Siding Standoff (4pc Kit)	13-1/2" x 13-1/2"
46DVA-VSKS	Vinyl Siding Standoff (Small Kit)	10-1/2" x 10-1/2"
46DVA-IS	Insulation Shield	9" x 9"
58DVA-WT	Wall Thimble	10-1/2" x 10-1/2"
58DVA-WTS	Wall Thimble (Small)	9" x 9"
58DVA-WTU	Wall Thimble Universal	9" x 9"
58DVA-CS	Ceiling Support	10-3/4" x 10-3/4"
58DVA-FS	Fire Stop	10-1/2" x 10-1/2"
58DVA-WFS	Wall Fire Stop	10-1/2" x 10-1/2"
58DVA-VSS	Vinyl Siding Standoff	19-1/2" x 19-1/2"
58DVA-VSK	Vinyl Siding Standoff (4pc Kit)	16" x 16"
58DVA-CF	Counter Flashing (Assembled)	16" x 16"
58DVA-CFK	Counter Flashing (4pc Kit)	16" x 16"
58DVA-IS	Insulation Shield	11" x 11"

VERTICAL TERMINATION - SINGLE

See the table on the previous page for minimum cutout dimensions or frame openings around wall venting. Make sure clearances to combustible material are maintained based on vent part used.

Note: Size of vents depends upon specific fireplace and cutout sizes vary according to the DuraVent or ICC part number used.

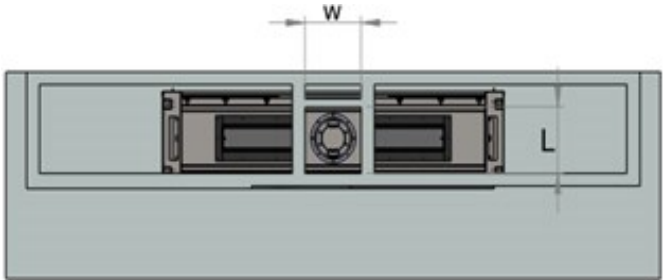
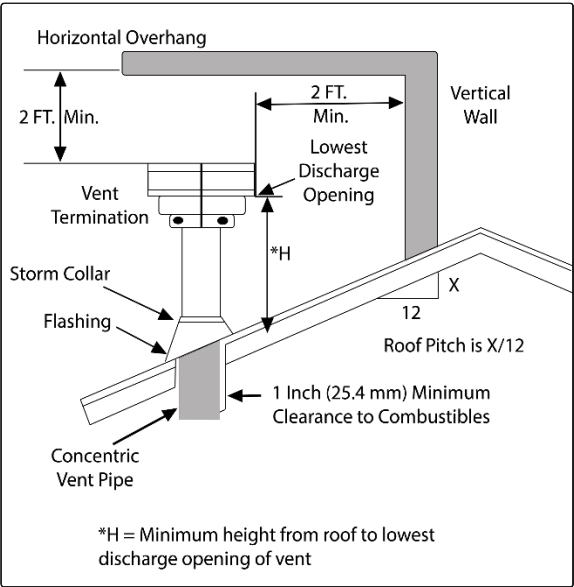

- Vertical Vent Termination Opening/Framing will depend on the part used. See table above or vent installation manual.
- Minimum of 24" horizontal clearance to any surface, such as an exterior wall, for vertical terminations.

Term. heights above flat/sloped roofs (Ref. NFPA 54 / ANSI Z223.1)

Pitch	Feet	Meters
Flat to 6/12	1'	0.3
6/12 to 7/12	1.25'	0.38
7/12 to 8/12	1.5'	0.46
9/12 to 9/12	2.0'	0.61
9/12 to 10/12	2.5'	0.76
12/12 to 11/12	3.25'	0.99
11/12 to 12/12	4.0'	1.22
12/12 to 14/12	5.0'	1.52
14/12 to 16/12	6.0'	1.83
16/12 to 18/12	7.0'	2.13
18/12 to 20/12	7.5'	2.29
20/12 to 21/12	8.0'	2.44

VERTICAL TERMINATION – DOUBLE

A	B
6" - 20"	18" Minimum
20" and over	0" Minimum

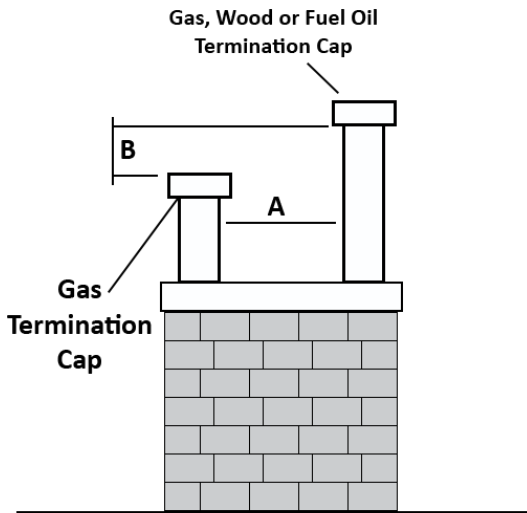

If using a decorative cap or cover, this distance may need to be increased. Refer to the Custom Chimney Shroud specification for details.

In a staggered installation with gas, wood, or fuel oil terminations, the wood or fuel oil termination cap must be higher than the gas termination cap.

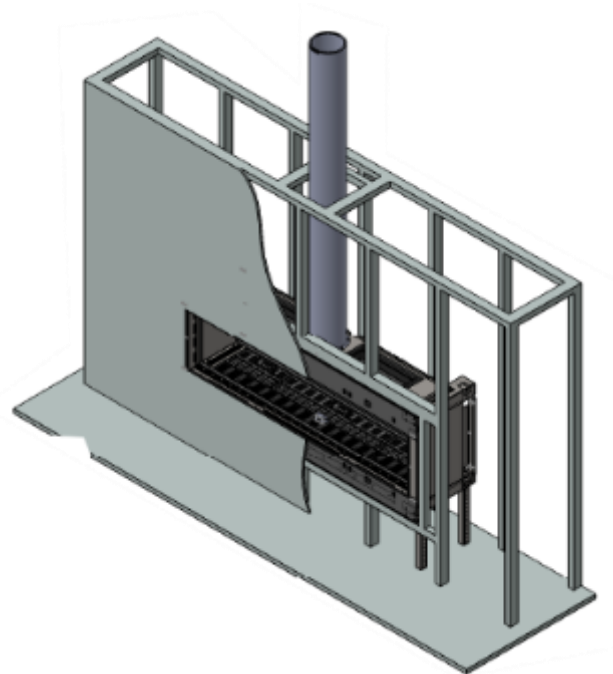

HORIZONTAL TERMINATION – DOUBLE

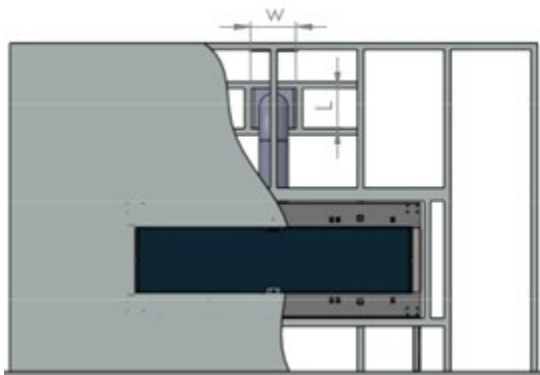

A minimum distance of 18 inches should be kept between multiple horizontal terminations. Make sure clearances to combustible material are maintained based on vent part used. Note: size of vents depends upon specific fireplace and cutout sizes vary per the DuraVent part number used.

VENT TERMINATION CLEARANCES

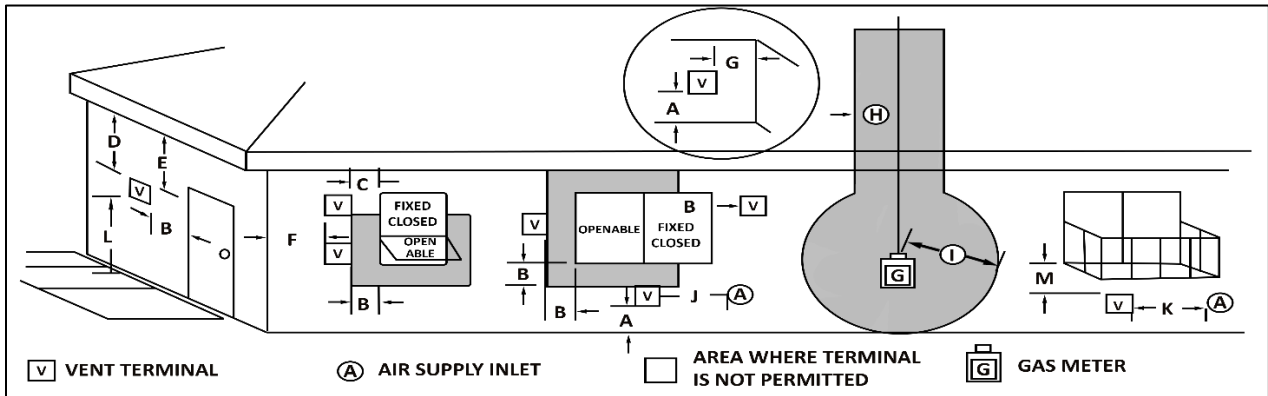

A	[^] 12" Min.	Clearances above grade, veranda, porch, deck, or balcony.
B	**12" Min.	Clearance to window or door that may be opened.
C	12" Min.	Clearance to permanently closed window.
D	80" & 100" Unit - 24" Min.	Vertical clearance to ventilated soffit, located above the terminal within a horizontal distance of 2' from edge of the terminal.
	70" & Below Unit - 18" Min.	
E	80" & 100" Unit - 24" Min.	Clearance to unventilated soffit.
	70" & Below Unit - 18" Min.	
F	6" Min.	Clearance to outside corner.
G	6" Min.	Clearance to inside corner.
H	3' Min.	*Not to be installed above a meter/regulator assembly within 3' horizontally from the centerline of the regulator.
I	3' Min.	Clearance to service regulator vent outlet.
J	*12" Min.	Clearance to non-mechanical air supply inlet to building or the combustion air inlet to any other appliance.
K	*6' Min.	Clearance to mechanical air supply inlet.
L	***7' Min.	Clearance above paved sidewalk or driveway located on public property.
M	***20" Min.	Clearance under veranda, porch, deck, or balcony.

[^] Vent shall not terminate directly above a sidewalk or paved driveway, located between two single family dwellings, serving both dwellings.

** Only permitted if veranda, porch, deck, or balcony is fully open on a minimum of 2 sides beneath the door.

* Clearance in accordance with local installation codes and the requirements of the gas supplier.

* As specified in CGA B149 Installation Codes, note local Codes or Regulation may require different clearances.

* For U.S.A. Installations follow the current National Fuel Gas Code, ANSI Z223.1

*** Horizontal vent termination minimum clearance to adjacent structure or fence is 48".

**** Minimum 24" horizontal clearance to any surface (such as an exterior wall) for vertical terminations.

SETTING UP FIREPLACE VENT RESTRICTOR

The Flare Fireplace direct vent system is equipped with a vent restrictor. Use Chimney Path Installation and Planning on the next page to determine the right vent restrictor setup for your installation. A certified installer or fireplace technician should only manage vent Restrictor changes and setup.

- Unit leaves the factory with the vent restrictor open.
- Vent restrictor is adjusted using a 100mm wrench, in between safety barriers, within the upper portion of the fireplace frame.
- The vent restrictor setting can be moved from 1-6, based on venting run.
- The installer must document the restrictor setting.
- Use the vent planning guide and table to determine restrictor setting.



WARNING!

The vent restrictor may need adjustment if any of the following are occurring:

- Flame is excessively tall or lifting from burner.
- Flames lack natural movement.
- Flame height is too low
- Flame has excessive movement.

DOCUMENT ANY CHANGES TO THE RESTRICTOR SETTING. CONTACT FLARE FOR ADDITIONAL SUPPORT



CHIMNEY PATH – INSTALLATION AND PLANNING

Before vent installation, the installer should read these instructions to ensure the proper vent configuration has been selected. To calculate the vent runs, use the following tables and instructions. Please note that power vent runs are model (burner) specific. Use the tables below to calculate the restrictor setting. These fireplaces are designed and evaluated to function with natural venting in equal pressure environments. Natural venting allows hot air and CO₂ to rise and exhaust out through the vent naturally while simultaneously creating a slight draft of oxygen to allow the flame to burn clean and efficiently. Please know that if your installation environment presents negative or positive pressure, caused by strong HVAC systems or kitchen hoods, a power vent system may be needed to counter this unique environment.

- Diagonal runs have both vertical and horizontal vent aspects when calculating the effects. Use the rise for the vertical aspect and the run for the horizontal aspect.
- Various combinations of vent runs may be used. Refer to the tables below based on Fireplace size. [Use the attached example](#) for clarification on how to use the table.
- The numbers in the table represent the restrictor setting based on the vent path.
- Symbol “X” in the table means the path is not allowed.
- Setting the restrictor to 1 means there is no restriction.
- Numbers in the table represent the restrictor setting to be set.
- Document the restrictor setting configuration prior to leaving the installation site.
- The tables apply to both NG (Natural Gas) and Propane.
- Minimum 3 ft vertical run (A) required before any bend or turn.
- A maximum of **four** 90° vent elbows are allowed in the vent run. Any configuration with more than 4 elbows requires vent review and approval from Flare Fireplaces.
- Two 45° elbows may be used in place of one 90° elbow.
- The tables represent the manufacturer’s guideline based on testing and design. Additional external factors may affect the restrictor choice needed. If flames appear to be not typical, please contact Flare Fireplaces for restrictor recommendations.
- Use the empty table in the page below to document and calculate the installation vent path.
- Any venting pathway that does not appear in the tables below require approval from Flare Fireplaces.

For optimum performance and flame appearance, keep the vent length to a minimum and limit the number of elbows.



FLARE TRADITIONAL – 39, 42, 46 TRIPLE GLASS

Length Calculation Guide	
Y - Effective Axis Parameters	
A - 1st Flue Length - 4ft. Minimum Rise	
B - Vertical Flue Length	
C - Roof Terminal = 1.5'	
H - 45-Degree Elbow = 1'	
X - Effective Axis Parameters	
D - Horizontal Flue Length	
E - 90-Degree Elbow = 3'	
F - Lying 90-Degree Elbow = 6'	
G - Wall Terminal = 3'	

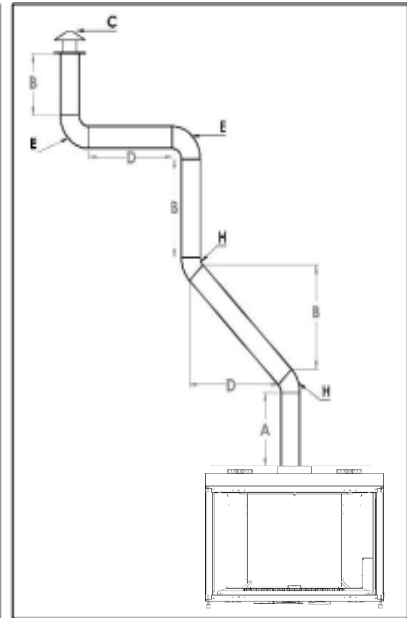
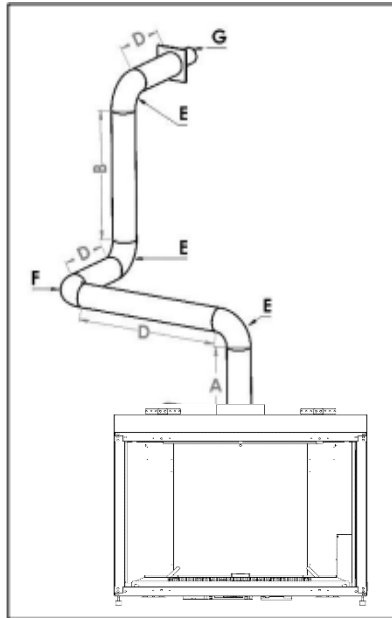

Vent Restrictor Setting: Set 1-6 based on vent run and the table below.
 X: Power Vented Run

Y - Effective Vertical Length	Flare TRA-39/42	X - Effective Horizontal Length												
	Feet	0'	3'	6'	10'	13'	17'	20'	23'	26'	30'	33'	36'	39'
4'	2	2	2	2	2	1	1	1	1	1	1	1	X	X
6'	3	3	2	2	2	2	1	1	1	1	1	1	1	1
10'	3	3	2	2	2	2	1	1	1	1	1	1	1	1
13'	3	3	2	2	2	2	1	1	1	1	1	1	1	1
16'	3	3	2	2	2	2	1	1	1	1	1	1	1	1
19'	2	2	2	2	2	2	1	1	1	1	1	1	1	1
23'	2	2	2	2	2	1	1	1	1	1	1	1	1	1
26'	2	2	2	2	2	1	1	1	1	1	1	1	1	1
30'	2	2	2	1	1	1	1	1	1	1	1	1	1	1
33'	1	1	1	1	1	1	1	1	1	1	1	1	1	1
36'	1	1	1	1	1	1	1	1	1	1	1	X	X	X
39'	1	1	1	1	1	1	1	1	1	1	1	X	X	X
43'	1	1	1	1	1	1	1	1	1	1	1	X	X	X
46'	1	1	1	1	1	1	1	1	1	1	X	X	X	X
50'	1	1	1	1	1	1	1	1	1	1	X	X	X	X



FLARE TRADITIONAL – 39, 42, 46 SCREEN

Length Calculation Guide	
Y - Effective Axis Parameters	
A - 1st Flue Length - 3ft. Minimum Rise	
B - Vertical Flue Length	
C - Roof Terminal = 1.5'	
H - 45-Degree Elbow = 1'	
X - Effective Axis Parameters	
D - Horizontal Flue Length	
E - 90-Degree Elbow = 3'	
F - Lying 90-Degree Elbow = 6'	
G - Wall Terminal = 3'	

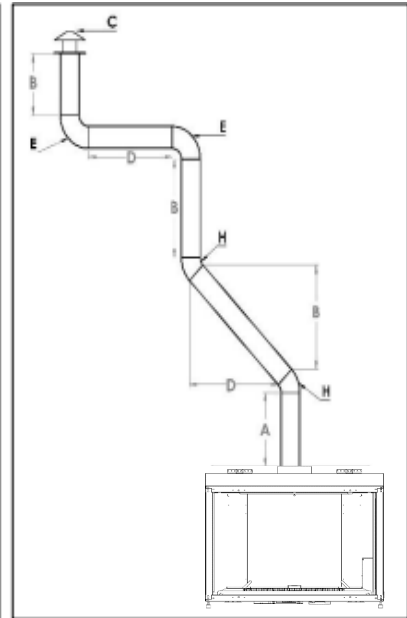
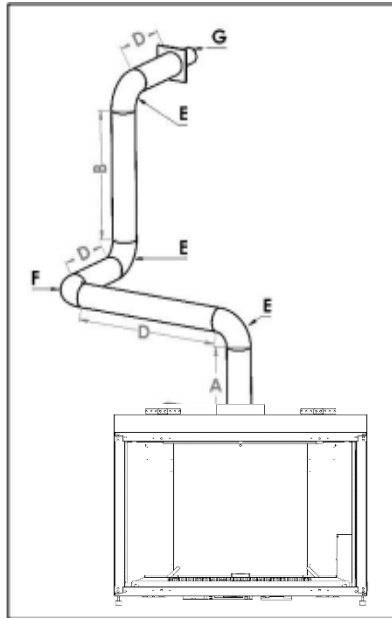

Vent Restrictor Setting: Set 1-6 based on vent run and the table below.
 X: Power Vented Run

Y - Effective Vertical Length	Flare TRA-39/42	X - Effective Horizontal Length												
	Feet	0'	3'	6'	10'	13'	17'	20'	23'	26'	30'	33'	36'	39'
3'	2	2	2	2	2	1	1	1	1	1	1	1	X	X
6'	3	3	2	2	2	2	1	1	1	1	1	1	1	1
10'	3	3	2	2	2	2	1	1	1	1	1	1	1	1
13'	3	3	2	2	2	1	1	1	1	1	1	1	1	1
16'	3	3	2	2	2	1	1	1	1	1	1	1	1	1
19'	2	2	2	2	2	1	1	1	1	1	1	1	1	1
23'	2	2	2	2	1	1	1	1	1	1	1	1	1	1
26'	2	2	2	2	1	1	1	1	1	1	1	1	1	1
30'	2	2	2	1	1	1	1	1	1	1	1	1	1	1
33'	1	1	1	1	1	1	1	1	1	1	1	1	1	1
36'	1	1	1	1	1	1	1	1	1	1	X	X	X	X
39'	1	1	1	1	1	1	1	1	1	1	X	X	X	X
43'	1	1	1	1	1	1	1	1	1	1	X	X	X	X
46'	1	1	1	1	1	1	1	1	1	X	X	X	X	X
50'	1	1	1	1	1	1	1	1	1	X	X	X	X	X

POWER VENTING

For unsupported vent routes (based on the gravity vent tables above) a power venting solution is required. The power venting solutions allow Flare Fireplaces to operate in vent conditions that would not be possible without the motor unit. See the [Flare Power Vent Installation Manual](#) for more specific instructions. The system is designed and evaluated with DuraVent 3x5 gasket direct vent pipes. It is critical for the safety and operation of the system to use the DuraVent 3x5 gasket system.

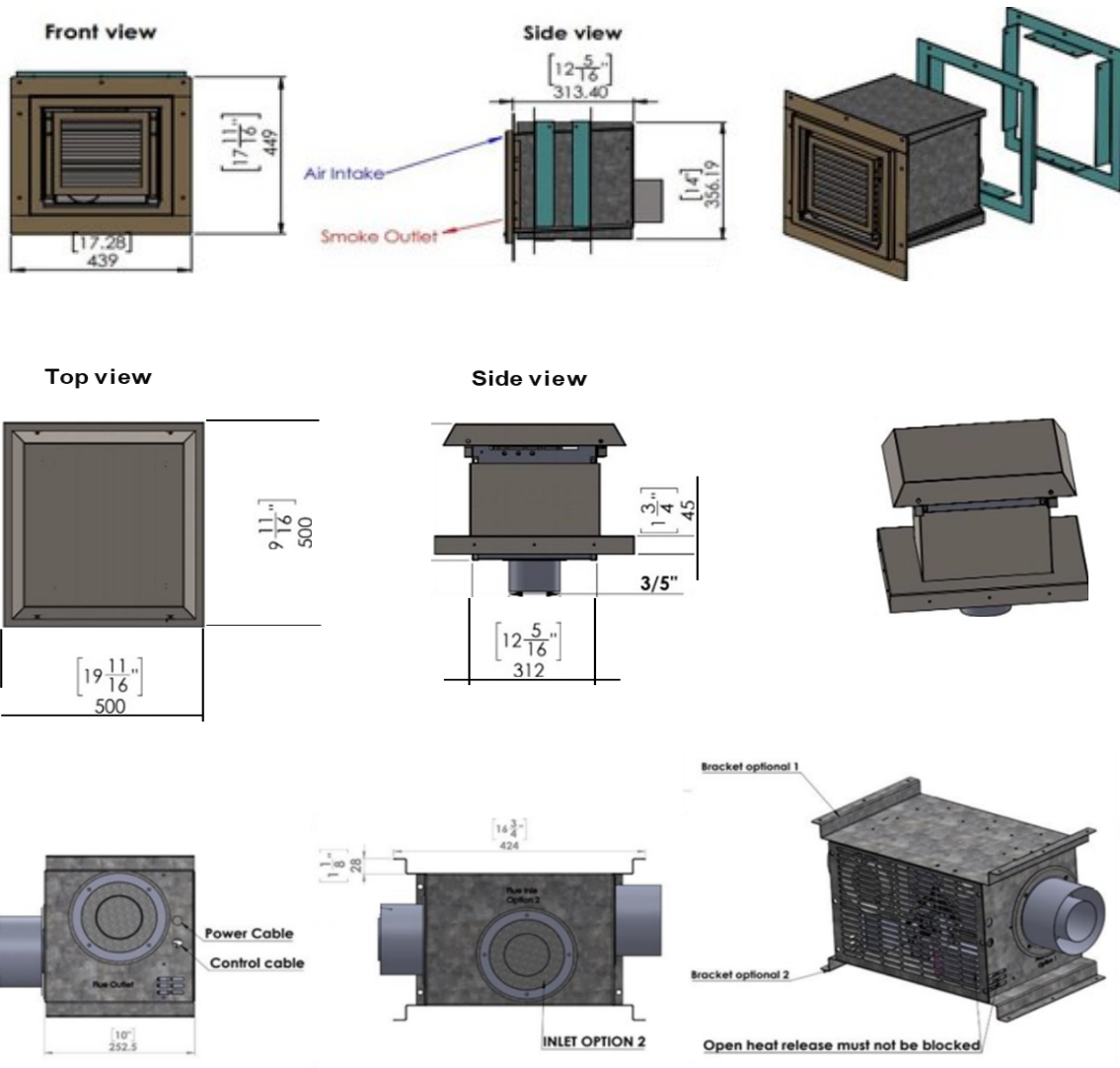



POWER VENT SPECIFICATIONS

When using the power vent system, direction of flow through the vents can be up, down, horizontal or diagonal since the system is sealed and vacuumed. The vent restrictor level should be set based on length in feet, number of elbows and the vent termination.

NOTE: A minimum length of **12ft venting** is required between the Fireplace and the power vent, Flare Traditional fireplaces. For more information, please reference the [Power Vent Installation Manual](#).

Clearance - Clearances between the vent pipe and combustible materials must be maintained at 3" inches top and 1" for side and below. Maintain the same clearance from the power vent box to any combustible materials.

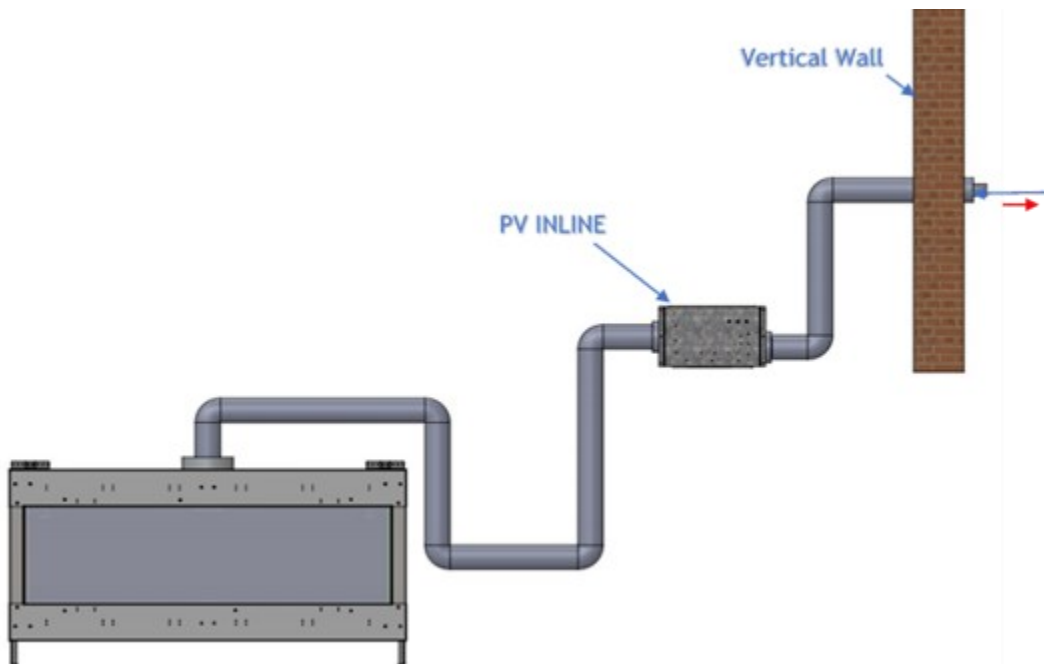

WARNING!

Failure to install, operate, and maintain the power venting system in accordance with manufacturer's instructions will result in conditions which may produce bodily injury and/or property damage

POWER VENT INTERNAL ELECTRICAL DRAWING

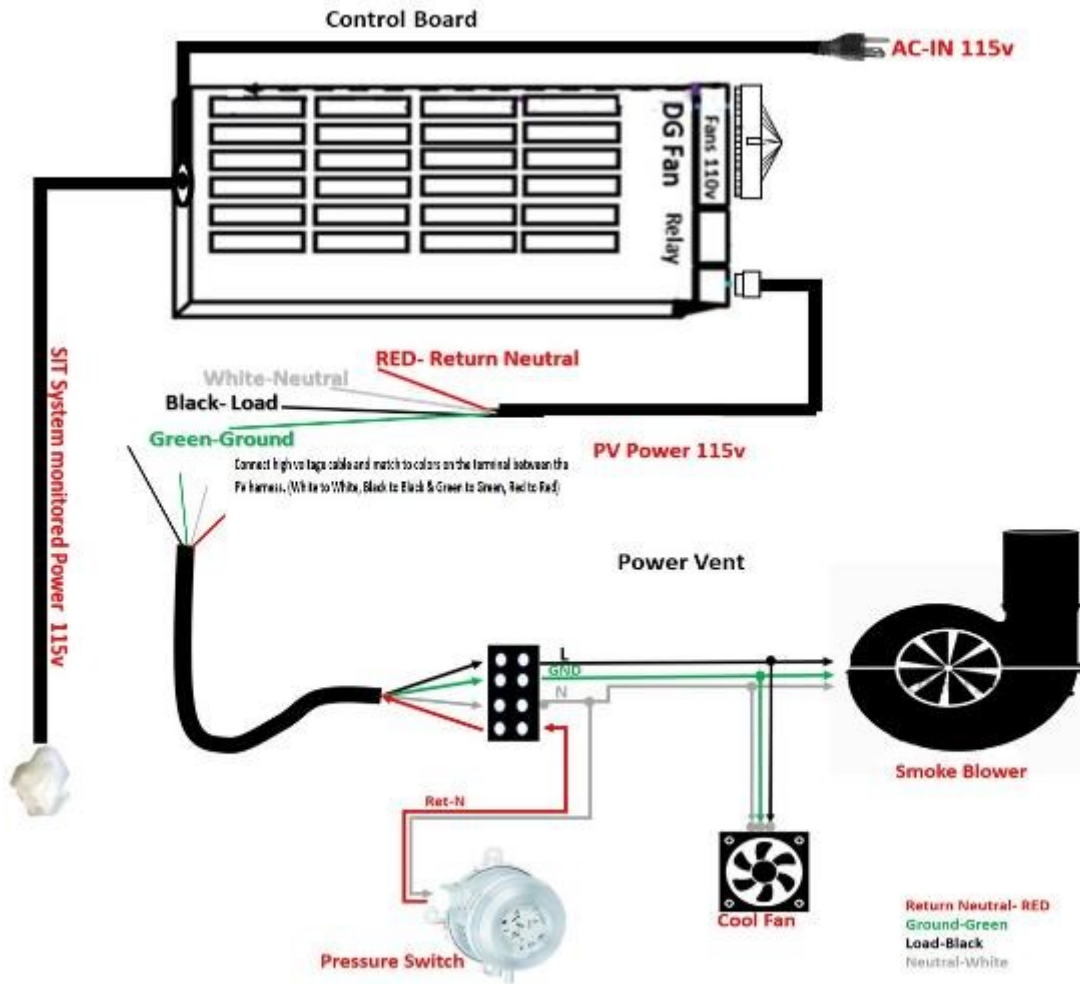



GAS INSTALLATION

WARNING! Risk of Fire or Explosion!

- All gas handling and installation should be performed by qualified service technician or installer.
- Gas build-up during line purge could ignite. Ensure adequate ventilation. Make sure there are no ignition sources/sparks or open flames.
- Do not change the gas valve setting! The fireplace gas valve has been preset at the factory.
- Installing an external manual gas valve before connection to the fireplace is necessary.
- Make sure to check for gas leaks before lighting the fireplace for the first time. When checking for leaks do not use open flame.

GENERAL

- This appliance and its individual shut off valve must be disconnected from gas supply piping system during any pressure testing of that system at test pressures more than ½ psig (3.5 kPa).
- This appliance must be isolated from the gas supply piping system by closing its individual manual shut off valve during any pressure testing of the gas supply piping system at test pressures equal to or less than 1/2 psig (3.5 kPa).
- Move the appliance into position and secure it to the wall using the back or side mount.
- Install a manual gas valve before the connection to the fireplace appliance automatic valve.
- Connect the gas line to the fireplace. The appliance is designed to accept a 1/2" (13mm) gas supply.
- Connect the gas supply in accordance with local codes, CAN/CSA-B149.1 in Canada or to the current National Fuel Gas Code, ANSI Z223.1 / NFPA 54 in the United States.
- Check for gas leaks using non-corrosive commercially available leak-check solution before operating the gas appliance.
- Measure and document gas pressure here: Inlet _____ W.C. Burner (Manifold) _____ W.C. Make sure the Min/Max inlet pressure match the table below.
- Lighting the fireplace for the first time may take some time until the line is purged.

Gas Pressure	Natural Gas	Propane
Inlet pressure	7.0" - 8.0" W.C	10" - 11.0" W.C

WARNING!

Do not place gas valve or components above burner line. Risk of explosion! High pressure will damage the valve. Low pressure could cause an explosion. Verify inlet pressures when other household gas appliances are operating.

GAS VALVE OVERVIEW

Have the gas supply line installed in accordance with local codes, if any. If not available, follow ANSI 223.1. Installation should be done by a qualified installer approved and/or licensed as required by the locality (in the Commonwealth of Massachusetts installation must be performed by a licensed plumber or gas fitter).

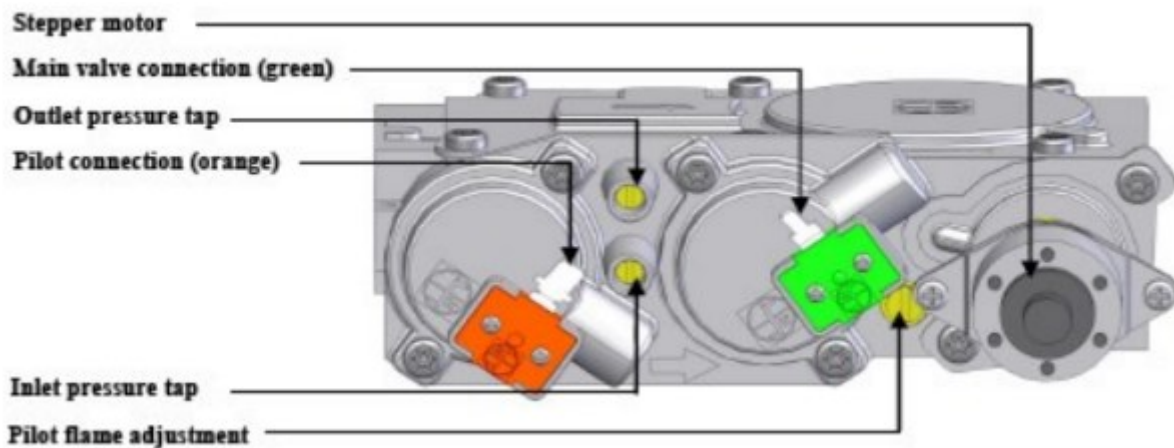



DE-RATING

Flare Fireplaces appliances use the SIT ProFlame II valve and are evaluated/approved for installations at elevations of 0–4500 feet (0–1372 meters) above sea level using the standard burner orifice sizes. At the time of installation, it must be determined by the installer if the appliance needs to be de-rated for elevations above 4500 feet. Contact your local gas supplier for the de-rating requirements in your area. Only use the Flare Fireplaces de-rating reducer on installations above 4500 Ft. **If the installer must convert the unit to adjust for varying altitudes, the information sticker must be filled out by the installer and adhered to the appliance at the time of conversion.**

DE-RATE TABLE

MODEL	GAS TYPE	REDUCER SIZE	CALC BTU.	STANDARD BTU
39"	NG	3.5 mm	35000	45000
42"	NG	3.5 mm	35000	45000
46"	NG	3.5 mm	35000	45000
39"	LPG	2.0 mm	27000	3500
42"	LPG	2.0 mm	27000	3500
46"	LPG	2.0 mm	27000	3500

ADDING REDUCER TO DERATE FIREPLACE AT ELEVATION

Add the de-rating reducer when your fireplace is being installed at elevations over 4500 ft above sea level. Please contact your local gas supplier for de-rating requirements in your area.

1. Shut off gas, remove power, and locate your gas valve. Once disconnected, verify direction of gas flow by locating the flow-arrow on top of the valve. Turn off gas and remove hard line to valve.

SEE EXAMPLE 1

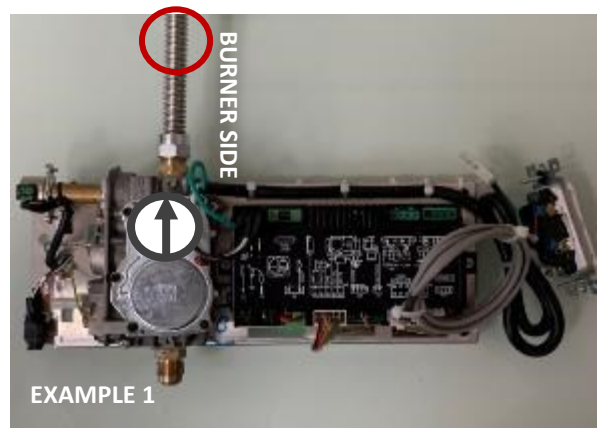

2. Add reducer between gas hard line and flex line connected to SIT ProFlame valve on the burner side. Use appropriate reducer as specified in "DE-RATE TABLE".

SEE EXAMPLE 2

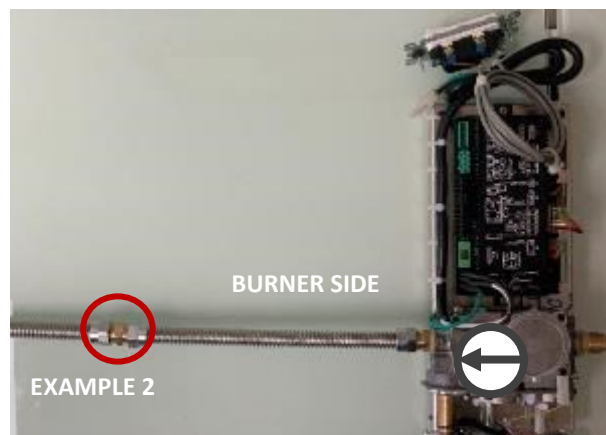



ORIFICE SIZE

Flare Fireplace appliances are evaluated and approved for installations at elevations of 0–4500 feet (0–1372 meters) above sea level using the standard burner orifice sizes. At the time of installation, it must be determined if the appliance needs to be de-rated. Contact your local gas supplier for derating requirements for your area. De-rated installation consideration can start at 2000 Ft above sea level. At higher elevations, the amount of BTU fuel value delivered must be reduced by either using gas that has been de-rated by the gas company or by changing the burner orifice to a smaller size as regulated by the local authorities that have jurisdiction and by the (USA) National Fuel Gas Code NFPA 54/ANSI Z223.1 - latest edition or in Canada, the CAN/CSA-B149.1 code – latest edition.

MANUAL GAS SHUT OFF

The installation of this appliance **REQUIRES** the implementation of a readily accessible Manual Gas Shut Off. Confirm requirements of location and shut off type with your local codes. **NOTE:** The Electronic Ignition of Flare Fireplaces **DOES NOT** satisfy the requirement for a Manual Gas Shut Off. See below for example of Manual Gas Shut Off





LIQUID PROPANE USAGE IN A FLARE FIREPLACE

The Flare Fireplace can operate and fire using Natural Gas (Default) or Liquid Propane gas. If your installation requires the fireplace to operate using Liquid Propane gas, make sure only to use the Flare Fireplaces liquid propane conversion kit.

Depending on your fireplace ignition system, LPG conversion kit may include the following:

- LPG burner orifices
- Pilot LPG orifices
- SIT Valve LPG Conversion Kit

Never operate a fireplace ordered for natural gas with LP gas unless converted by a certified fireplace technician. Use only flare fireplace LP conversion kit. Always measure gas inlet pressure and outlet pressure post conversion

Your fireplace may be shipped to support Liquid Propane Gas. Check your Flare Fireplaces gas rating plate at the back of your valve to confirm the gas type.

[Use the following link for the Flare Fireplace NG to LPG conversion on SIT ignition](#)

NOTICE

Flare Fireplaces does offer the ability to run your fireplace with a liquid propane tank though there are certain limitations this fuel type presents when compared to the usage of natural gas. Liquid propane burns more efficiently and hotter than natural gas so to accommodate this increase in heat we must use smaller orifices to achieve a lower BTU that can cause your flame to appear smaller than on a unit run on natural gas. Flame height on Flare Fireplaces using Liquid Propane is roughly 4-6" in height because of this adjustment.



COMMONWEALTH OF MASSACHUSETTS

State of Massachusetts Carbon Monoxide

Detector/Vent Terminal Signage Requirements for all side wall horizontally vented gas fueled equipment installed in every dwelling, building or structure used in whole or in part for residential purposes, including those owned or operated by the Commonwealth and where the side wall exhaust vent termination is less than seven (7) feet above finished grade around the venting, including but not limited to decks and porches, the following requirements shall be satisfied:

1. **INSTALLATION OF CARBON MONOXIDE DETECTORS.** At the time of installation of the side wall horizontal vented gas fueled equipment, the installing plumber or gas fitter shall observe that a hard-wired carbon monoxide detector with an alarm and battery back-up is installed on the floor level where the gas equipment is to be installed. In addition, the installing plumber or gas fitter shall observe that a battery operated or hard-wired carbon monoxide detector with an alarm is installed on each additional level of the dwelling, building or structure served by the side wall horizontal vented gas fueled equipment. It shall be the responsibility of the property owner to secure the services of qualified licensed professionals for the installation of hard-wired carbon monoxide detectors.
 - a. If the side wall horizontally vented gas fueled equipment is installed in a crawl space or an attic, the hard-wired carbon monoxide detector with alarm and battery back-up may be installed on the next adjacent floor level.
 - b. If the requirements of this subdivision cannot be met at the time of completion of installation, the owner shall have a period of thirty (30) days to comply with the above requirements; provided, however, that during said thirty (30) day period, a battery-operated carbon monoxide detector with an alarm shall be installed.
2. **APPROVED CARBON MONOXIDE DETECTORS.** Each carbon monoxide detector as required in accordance with the above provisions shall comply with NFPA 720 and be ANSI/UL 2034 listed as IAS certified.
3. **SIGNAGE.** A metal or plastic identification cation plate shall be permanently mounted to the exterior of the building at a minimum height of eight (8) feet above grade directly in line with the exhaust vent terminal for the horizontally vented gas fueled heating appliance or equipment. The sign shall read, in print size no less than one-half (1/2) inch in size, "GAS VENT DIRECTLY BELOW. KEEP CLEAR OF ALL OBSTRUCTIONS".
4. **INSPECTION.** The state or local gas inspector of the side wall horizontally vented gas fueled equipment shall not approve the installation unless, upon inspection, the inspector observes carbon monoxide detectors and signage installed in accordance with the provisions of 248 CMR 5.089(2)(a) 1 through 4.

(b) **EXEMPTIONS.** The following equipment is exempt from 248 CMR 5.089(2)(a) 1 through 4.



1. The equipment listed in Chapter 10 entitled "Equipment Not Required to Be Vented" in the most current edition of NFPA 54 as adopted by the Board; and
2. Product Approved side wall horizontal vented gas fueled equipment installed in a room or structure separate from the dwelling, building or structure used in whole or in part for residential purposes.

(c) MANUFACTURER REQUIREMENTS – GAS EQUIPMENT VENTING SYSTEM PROVIDED.

When the manufacturer of Product Approved side wall horizontally vented gas equipment provides a venting system design or venting system components with the equipment, the instructions provided by the manufacturer for installation of the equipment and the venting system shall include:

1. Detailed instructions for the installation of the venting system design or the venting system components; and
2. A complete parts list for the venting system design or venting system.

(d) MANUFACTURER REQUIREMENTS – GAS EQUIPMENT VENTING SYSTEM NOT PROVIDED.

When the manufacturer of a Product Approved side wall horizontally vented gas fueled equipment does not provide the parts for venting the fuel gases, but identifies "special venting systems", the following requirements shall be satisfied by the manufacturer.

1. The referenced "special venting system" instructions shall be included with the appliance or equipment installation instructions; and
2. The "special venting systems" shall be Product Approved by the Board, and the instructions for that system shall include a parts list and detailed installation instructions.

(e) A copy of all installation instructions for all Product Approved side wall horizontally vented gas fueled equipment, all venting instructions, all parts list for venting instructions, and/or all venting design instructions shall remain with the appliance or equipment at the completion of the installation.



POWER REQUIREMENTS

Screen Unit: 110V, 15A Outlet (Dedicated circuit is optional but recommended) or directly wired. When using an outlet, make sure the outlet is accessible in the event of servicing.

**110V, 15A additional power source needed if Optional RGB-LEDs are included in unit.

Triple Glass: 110V, 15A Outlet (Dedicated circuit is optional but recommended) or directly wired. When using an outlet, make sure the outlet is accessible in the event of servicing.

**No additional power source needed for optional RGB-LEDs, unless installing independent of fireplace.



TELEVISION MOUNTING ABOVE FIREPLACE

The Flare Fireplace frameless design directs the heat from the fireplace into the fireplace chase to be released from the top vent opening. The design allows for a relatively low temperature on the external wall above the fireplace.

Follow the charts and instructions below for suggested installation of a television above the fireplace.

- Please note that the electric wiring used for the television must be insulated when installed inside the chase above the fireplace.
- It is critical that wiring insulation **does not** obstruct the hot air flow from going to the top part of the chase to be released back to the room.
- Placing insulation above the fireplace will result in a Fire hazard.
- The air flow above the fireplace should remain open to allow heat to be released from the top of the chase.
- **It is recommended to double wall** the area behind the TV to allow cables and other related material to be installed with less concern of blocking hot air flow. Use non-combustible material for double wall.
- All wires **MUST** be secured and anchored to the frame to prevent any possibility of wires dropping on top of the Fireplace.
- TV can be recessed when installed above the Fireplace, be protected by a mantel, or flush installed above the fireplace.
- Wires should be inserted into the recess from the top or sides (In order to avoid proximity to the fireplace vent).
- To reduce the amount of heat around and below the TV, **increase** the size of the heat release **above the minimum** required for your fireplace size unit.

*Please note that most television manufacturers and manuals will instruct the owner **not to install** television above or near a fireplace. Mounting a television above the fireplace is based on the owner's decision and responsibility. Flare will not be held liable for any adverse effects on a TV, artwork or other equipment located near the Flare appliance. It is the customer's responsibility to verify that their TV or artwork can withstand the wall temperatures at the installation site.

TV INSTALL – FLAT EXAMPLE

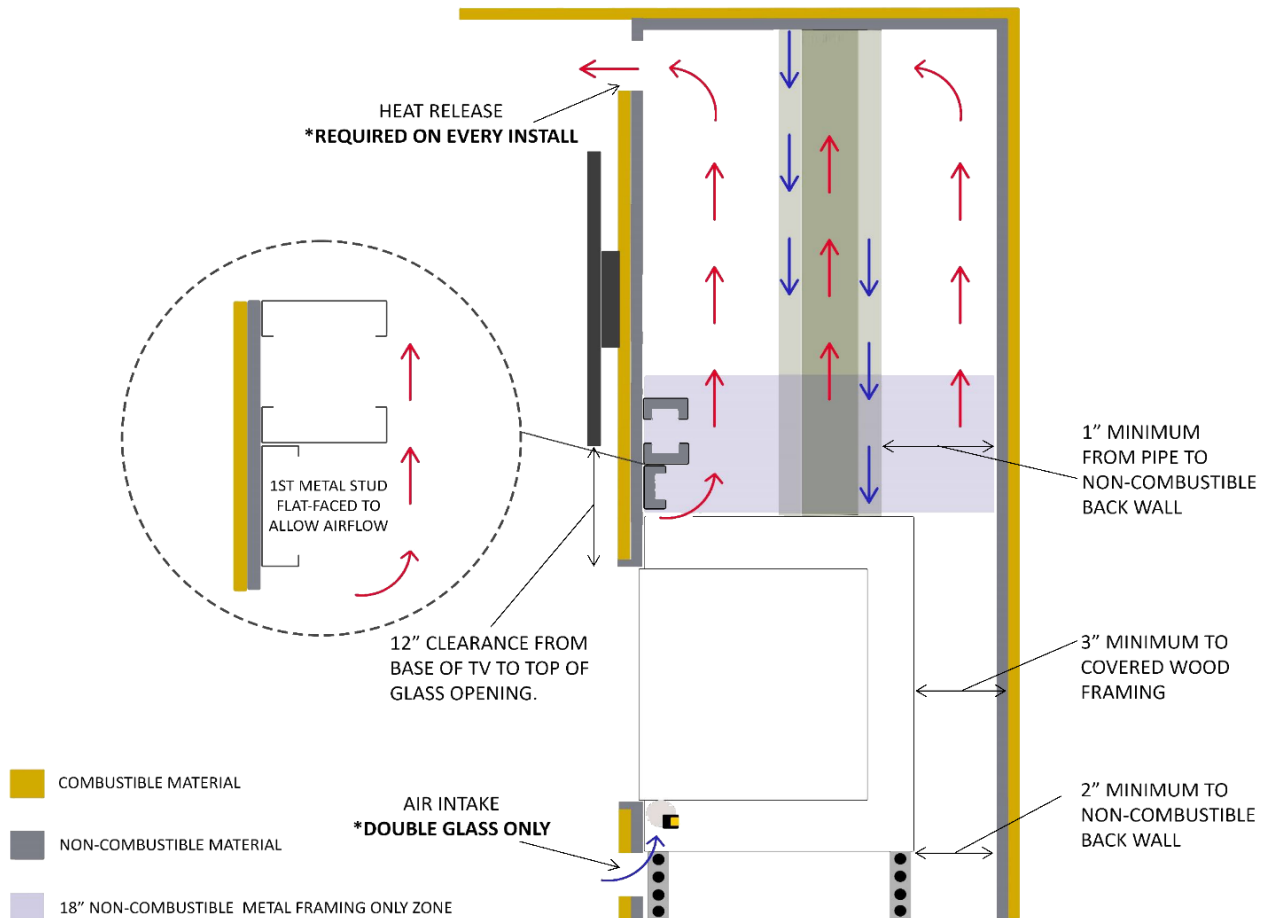

**The example shown above is not an exact rendering of every fireplace style and vent placement offered by flare but meant to convey relevant measurements for use on all unit installations. For exact drawings of the fireplaces and their vent placement please download dimension or framing guides from our [Direct Vent Download Center](#)

WARNING – Maintain Open Air flow between the fireplace and drywall. Make sure cables or any other materials are not blocking hot air flow.

TV INSTALL – L TYPE E

L-SHAPED (RECESSED)

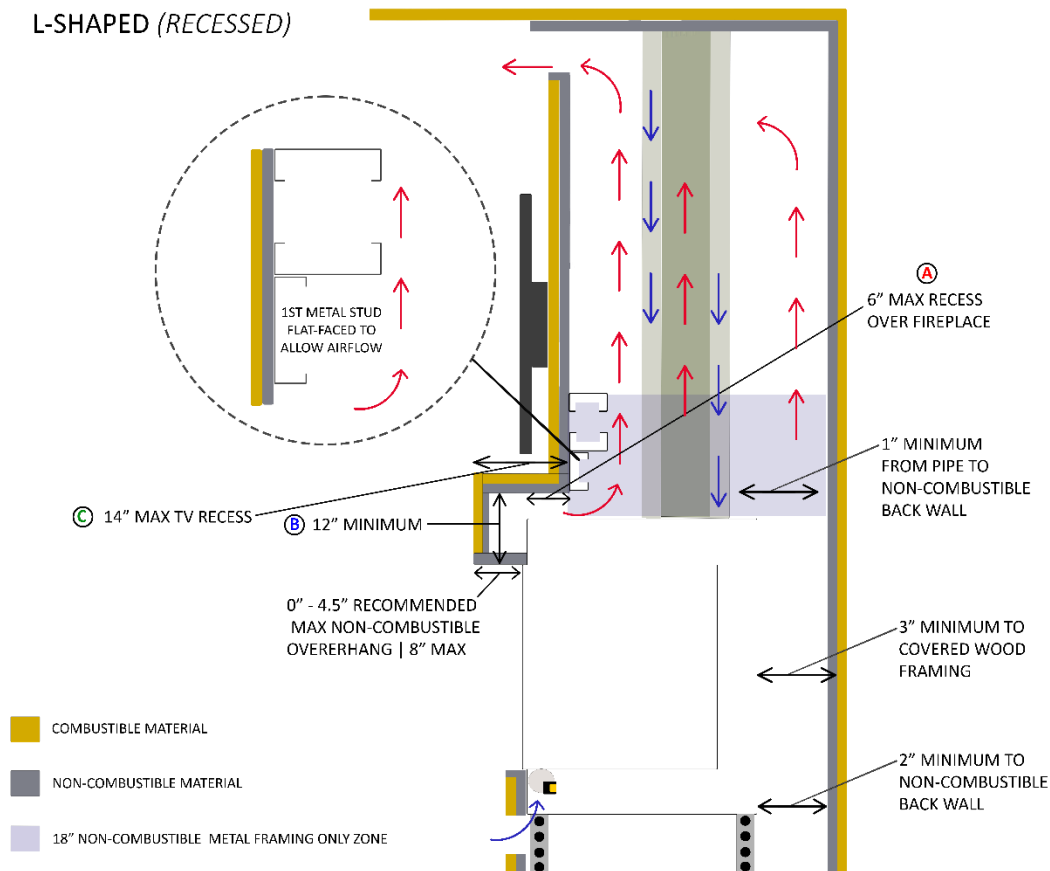

- A. Directly over the fireplace the television recess should be no deeper than 6" inches.
- B. A minimum of 12" above the top of the fireplace glass opening to the underside of the recess.
- C. Extending the overhang to the max of 8" and recessing into the cavity to the max of 6" can create an overhang up to 14" deep.

NOTE: Use non-combustible framing and finishing materials for overhang construction, making sure finishing materials do not extend into the glass installation zone. Do not recess deeper than 14" from the face of your finishing material to the back of the recess, it will hinder air flow & damage the TV.

**The example shown above is not an exact rendering of every fireplace style and vent placement offered by Flare but meant to show relevant measurements for use on all unit installations. For exact drawings of the fireplaces and their vent placement please download dimension or framing guides from our [Direct Vent Download Center](#)

WARNING – Maintain Open Air flow between the fireplace and drywall. Make sure cables or any other materials are not blocking hot air flow.



TV INSTALL RECESS – 45 DEGREE ELBOW ON TOP OF THE UNIT

When planning a TV recess, clearance to the vent pipe in the chase is critical and needs to be a minimum of 1" to the non-combustible recessed wall. This is to prevent heat from radiating from the vent to the recessed wall and being transferred to the TV.

Due to the central location and diameter of the vent (8 inches) on our Traditional 39", 42", and 46" models, one of the following solutions may be necessary to maintain the clearance requirement:

1. The television recess should be no more than 6" inches deep, **12" above the top of the fireplace glass opening**. You must maintain a 1" clearance from your recess to the vent pipe to prevent overheating.
2. Install two 45 elbows directly above the fireplace followed by a minimum 4 ft vertical vent rise. The two small elbows will move the vertical section back 5 5/8". Note that the 1-inch clearance from the vent applies also to the back non-combustible wall.
3. Do not use any elbow with an angle larger than 45 degrees.
4. A **4 ft** minimum vertical vent rise must be used after the **two 45-degree** elbows on fireplaces sized **39", 42", 46"**

Note: Max recess of TV into the cavity should not exceed 6". Recesses exceeding this dimension run the risk of creating a shelf and hindering air flow above unit, resulting in a wall that may overheat.

5. **The following vent path should be used for Flare Traditional 39", 42", and 46" only.**

5x8	
Offset	Rise
5 5/8"	15 3/8"

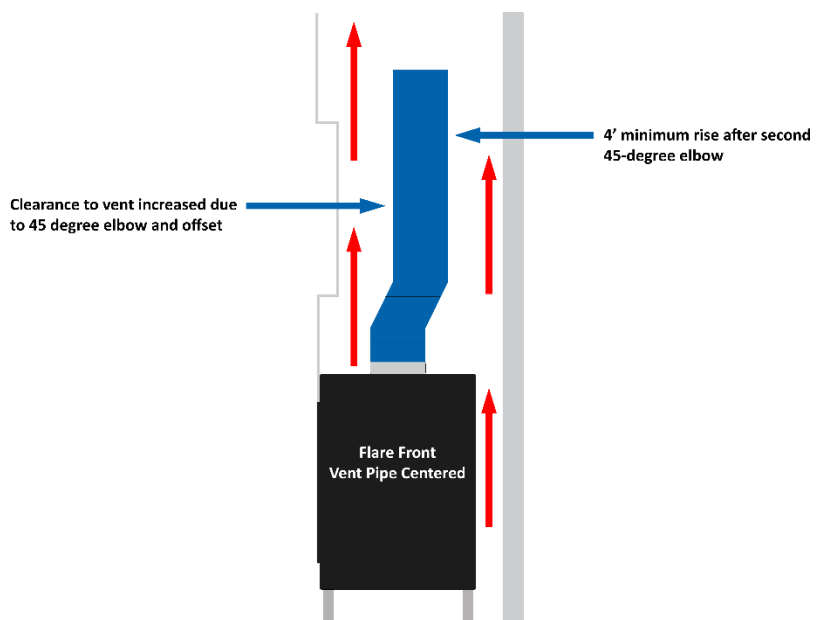
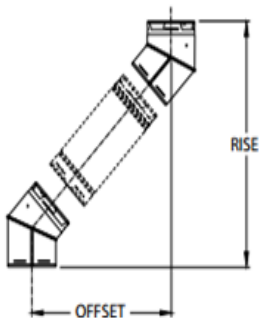

TV INSTALL FLUSH WITH MANTEL

Minimum Requirements for Installing a Television flush with a mantel above:

- The TV must be at least 11 Inches total above the glass of the fireplace.
- Mantel 1 inch thick and 6 inches deep should be installed a minimum of 8 inches above the glass.
- TV must be at least 2 inches above the mantel and 1 inch back from the edge of the mantel.
- To reduce the heat around the TV, increase the size of the heat release above the minimum requirement.
- All measurements shown are minimum requirements.

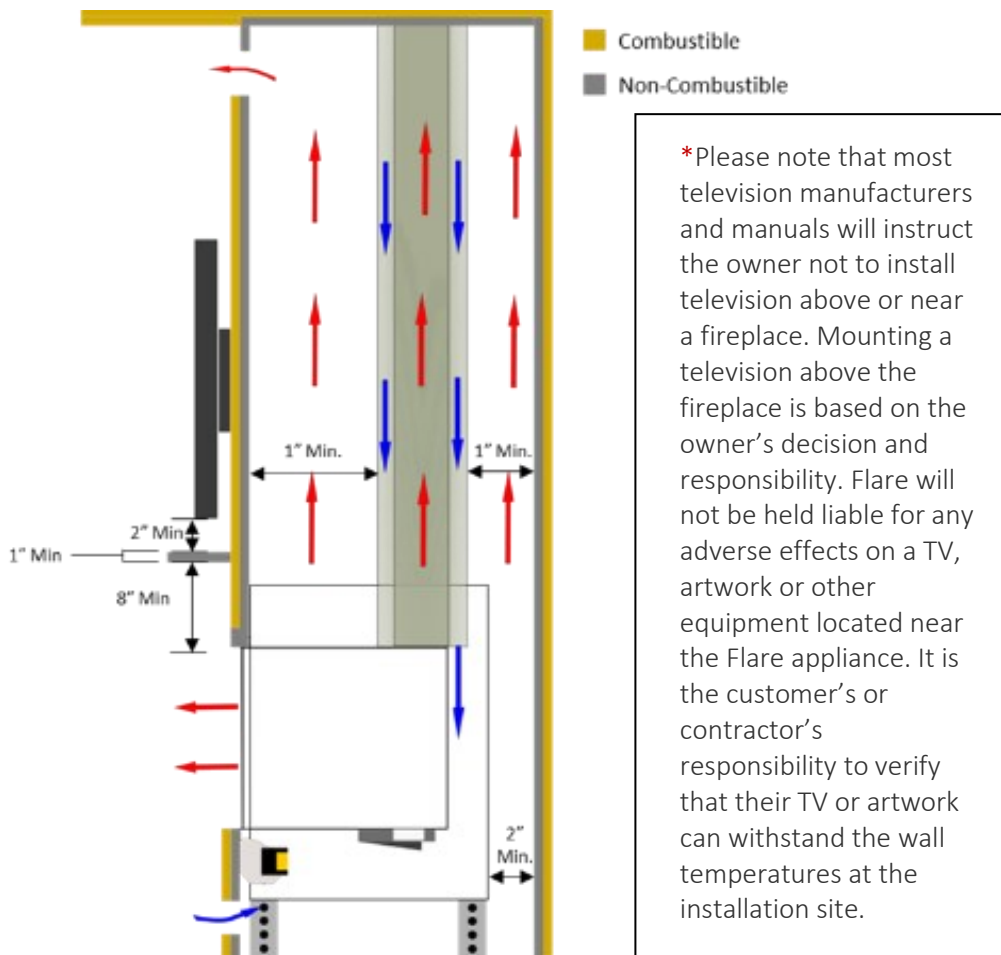

**The example shown above is not an exact rendering of every fireplace style and vent placement offered by flare but meant to convey relevant measurements for use on all unit installations. For exact drawings of the fireplaces and their vent placement please download dimension or framing guides from our [direct vent download center](#)

CLEARANCES

METAL FRAMING SPECIFICATIONS

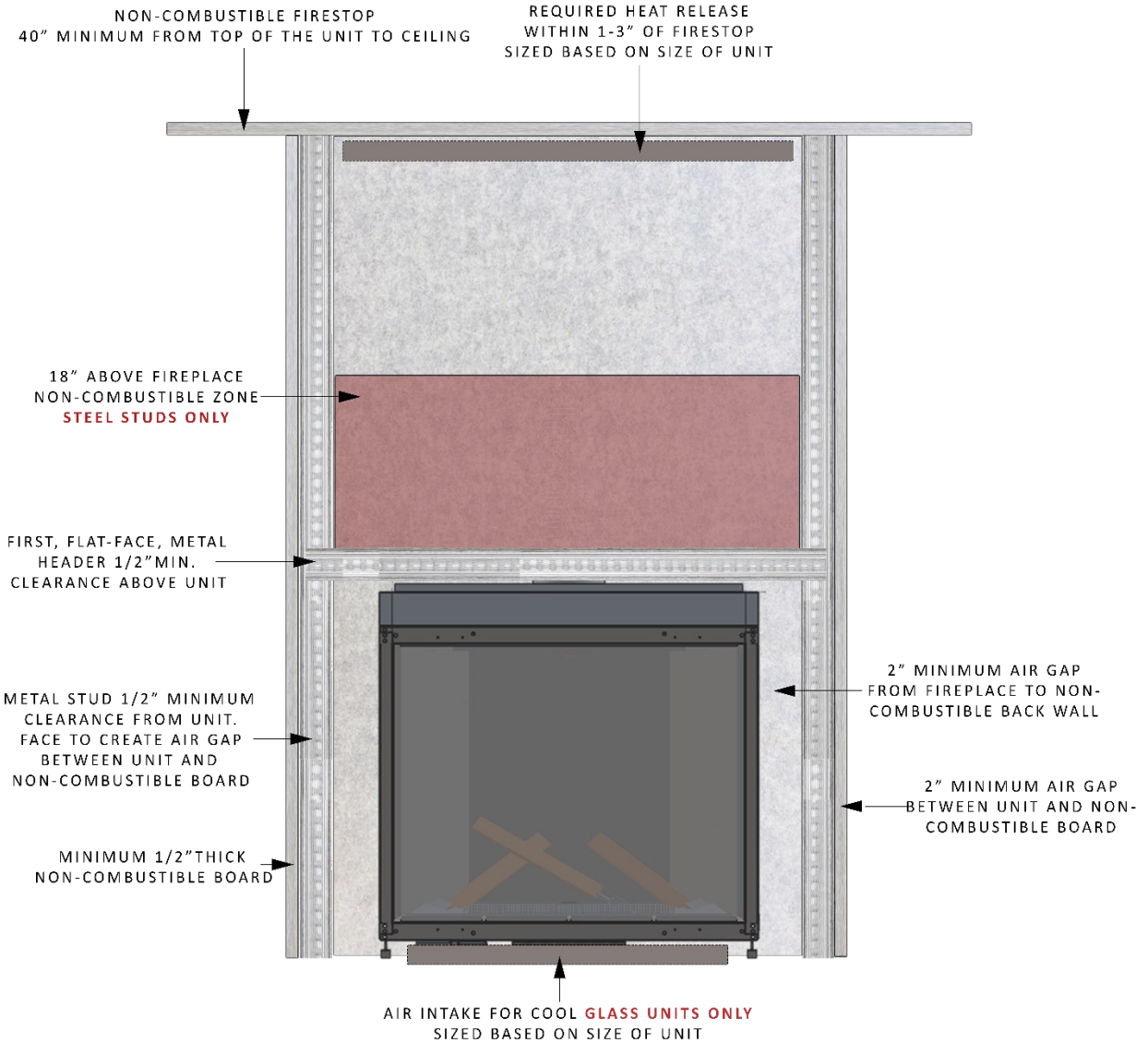

FOR MORE DETAILED FRAMING INFORMATION PLEASE REFER TO YOUR UNIT SPECIFIC FRAMING GUIDE

WOOD FRAMING SPECIFICATIONS

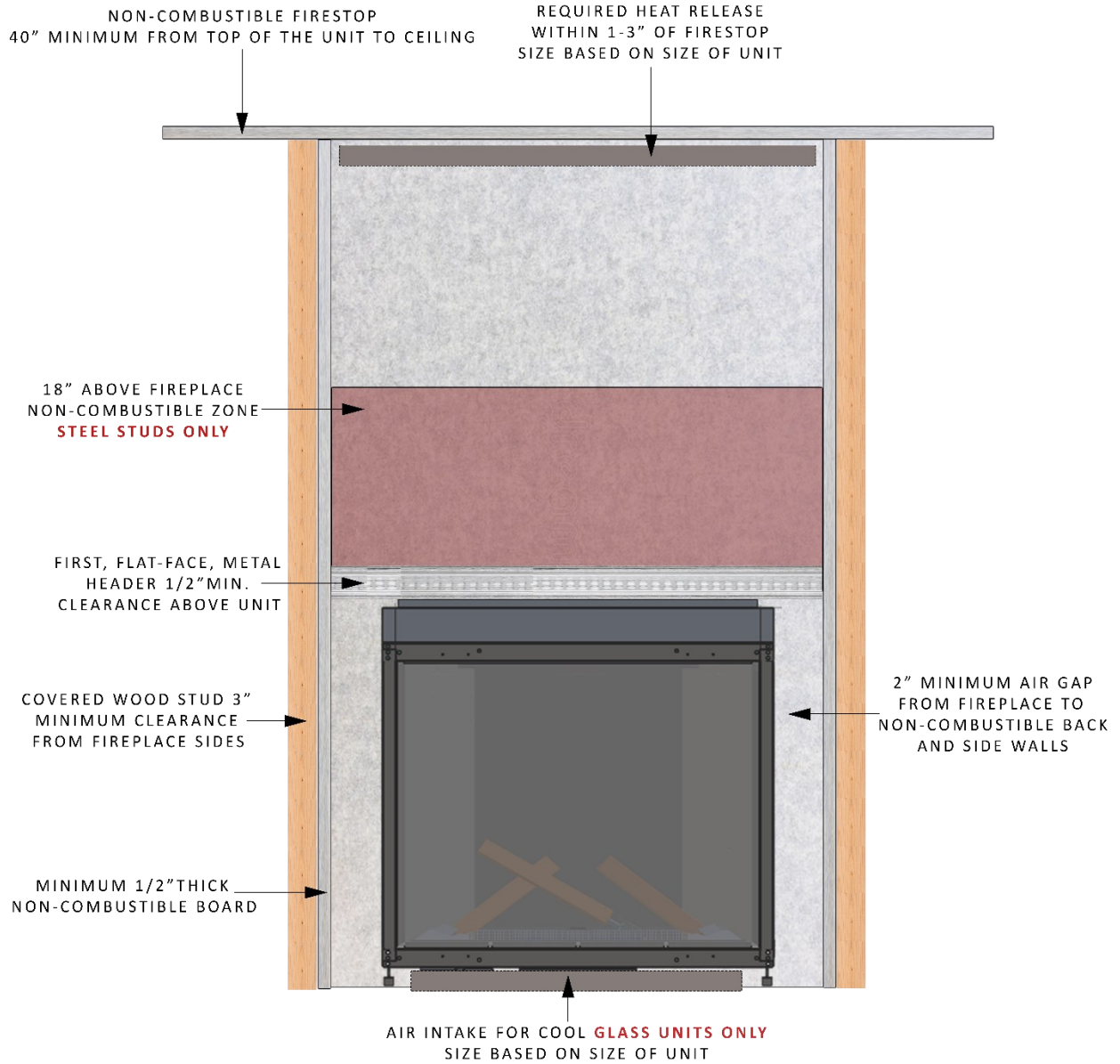

FOR MORE DETAILED FRAMING INFORMATION PLEASE REFER TO YOUR UNIT SPECIFIC FRAMING GUIDE



1. **Floor clearance** – The minimum clearance to floor is 2 inches. Recessing the legs to the floor is not a recommended setup and should be avoided.

NOTE: Install appliances on hard metal, cement board, drywall, or wood surfaces, extending full width and depth.

WARNING! - DO NOT install directly on carpeting, vinyl, or any combustible material other than wood.

2. **Front clearance** - Do not put furniture or any combustible objects within 36 inches (914 mm) of glass in front of appliance.
3. **Clearance to Metal frame** – Clearance to metal frame is 1/2-inch (12.7 mm) minimum. In the chase, a metal header is required 18 inches above the fireplace if framing is needed. Above that, wood studs covered by non-combustible material are allowed. See the next page for details.

4. **Minimum Combustible Clearances from Vent Pipe** –

- **HORIZONTAL VENT PIPE CLEARANCES:** A minimum clearance of 3 inches (76mm) to the top and 1 inch (25mm) to the sides and bottom of the vent pipe on all horizontal runs, to combustibles, is required, and must be level or have a minimum 1/4 inch (6mm) rise per 1-foot run towards the termination.
- **VERTICAL VENT PIPE CLEARANCES:** A minimum of 1 inch (25mm) around the vent pipe on all vertical runs, to combustibles, is required. Except for clearances in appliance enclosures.

WARNING! - Never allow the vent to run downward. A downward slope can trap heat and become a possible fire hazard. Maintain vent clearance to combustibles as detailed above. DO NOT pack air space with insulation or other materials. Failure to keep insulation or other materials away from vent pipe could cause overheating and fire.

WARNING! - Flare fireplaces are not designed to be load bearing or support weight of any architectural framing. All framings should be self-supported, supported by back wall, side wall, or ceiling. Attempting to mount framing to a fireplace subjects' glass to unsupported weight and could result in damage to fireplace or breakage of glass. Improper framing or mounting to unit will void product warranty. Please consult Flare Fireplaces directly for additional questions or concerns about framing options.

5. **Mantel Clearance** – Combustible mantel clearance can vary according to the mantel's depth and height. Use table and diagram on page 86 for guidelines on Mantel Installation

6. **Fireplace shelf enclosure** – The minimum height to the inside of a shelf above the top of the fireplace is 6 inches (**12 inches above the glass**). This shelf must be built with non-combustible material at least 5/8” thick. Due to the low size of the shelf enclosure, it is recommended to build the enclosure using Skamol board. The Skamol board is a light non-combustible material that can help prevent the formation of cracks and is a good insulator. *The shelf enclosure **MUST** have a heat release opening either centered on top of your shelf, or on both the front and back placed on the longest face of the surround. See example below



NOTE: If choosing to place the heat release on the face of your surround, instead of centered on top of the surround, the opening must be on both the front and back of the cavity. **It cannot only be on the short-sides** but can be on all sides.

- A. Required heat release on top of shelf enclosure, sized based on size of the fireplace. [Heat Release Specification Manual](#)
- B. 12” minimum from glass opening to underside of non-combustible board within shelf enclosure.

WARNING!

*Room Definer fireplaces, depending on the surround configuration, may require an additional heat release to alleviate heat build-up caused by the vent pipe. Please contact Flare Fireplaces at 1 (866) 639-1590 to verify your application is safe.

7. **Ceiling Clearance** - The minimum ceiling height for a Flare Fireplace is 40" above the top of the fireplace.

The heat released above the fireplace is critical for keeping the chase and surrounding walls at a relatively low temperature.

8. **Minimum clearance to sides and back - Non-combustible** – The minimum clearance from the back and sides of the fireplace to any **non-combustible** material (i.e., cement board or Type X fire rated board) is 2 inches. This clearance allows for proper air flow.
9. **Minimum clearance to sides and back** – Covered combustible material at the back or sides of the fireplace, **MUST** be covered with non-combustible material that is at least ½ inch thick. Covered wood can be placed a minimum of 3" away from the side and back.

Example: A non-combustible cement board is placed 2 ½" inches from the back of the fireplace. The cement board used is ½" inch thick. Combustible material can be used behind cement board as it is a total of 3 inches away from the back of the fireplace and is covered with a non-combustible material.

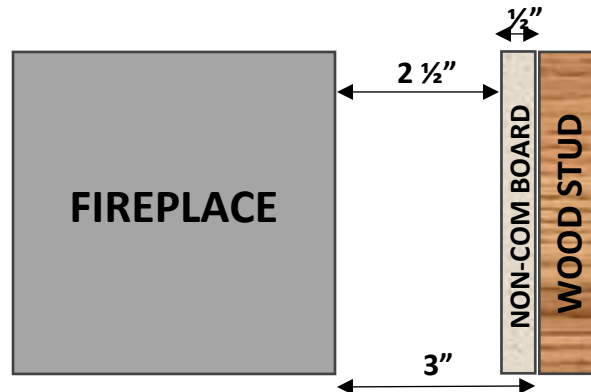

10. **Minimum clearance to sides and back** - Combustible material at the back or sides of the fireplace, below the non-combustible line is **8"**. Please note this **does not** include minimum clearance directly above the fireplace inside the chase. Please see items starting at 12.
11. **Minimum clearance directly above the fireplace inside the chase** – All non-combustible studs to be installed a minimum of ½" away from the fireplace. Metal studs should not connect to the fireplace or touch the fireplace. Doing so will result in heat transfer from the fireplace to the metal stud. Make sure not to block hot air flow to the heat release.

12. Minimum clearance directly above the fireplace inside the chase – Combustible

- First 18" directly above the fireplace **MUST** be framed using non-combustible material. Metal Studs. **Zone A**
- All combustibles above the 18" must be covered. **Zone B.**

There should be no combustible materials left uncovered above the fireplace inside the chase.

Fireplace chase should be designed and built to allow warm air to release from the unit and rise-up in a non-combustible channel to the heat release.

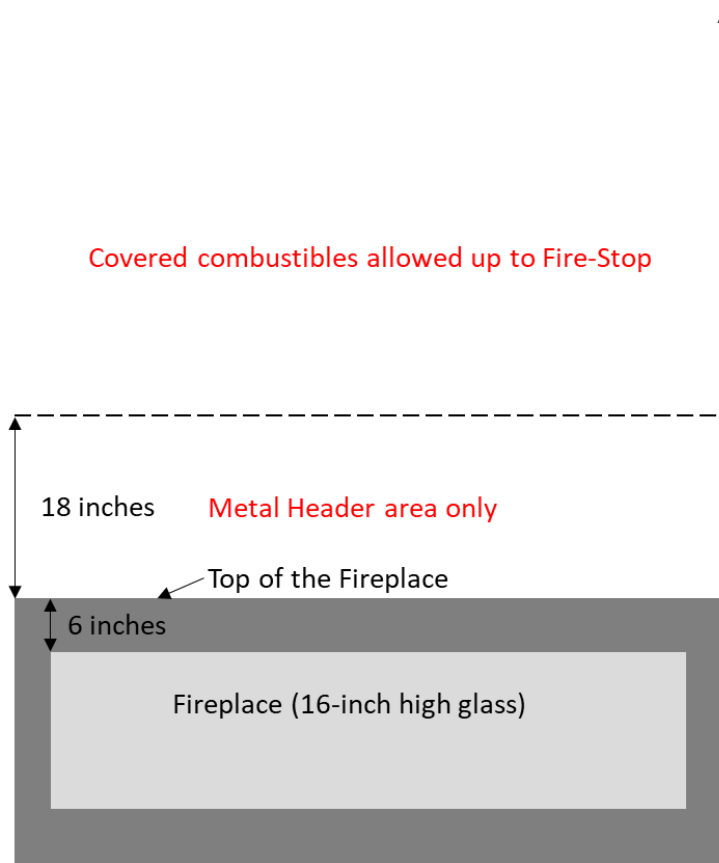

13. Chase ceiling - Top of the chase must be covered with noncombustible material (Firestop). No exposed combustible materials are allowed inside the chase.

14. Hearth Clearances –

- A. Clearance to an **uncovered combustible hearth** below the glass is **2 inches** as seen in **EXAMPLE 1**
- B. When bringing your hearth to glass height it must be non-combustible for the first 7” extending from the glass before any combustible material can be used to finish the hearth. As seen in **EXAMPLE 2**

15. Adjacent Wall 1 – Distance to any side of the adjacent wall must be at least 7 inches from the glass. As seen in **EXAMPLE 1**

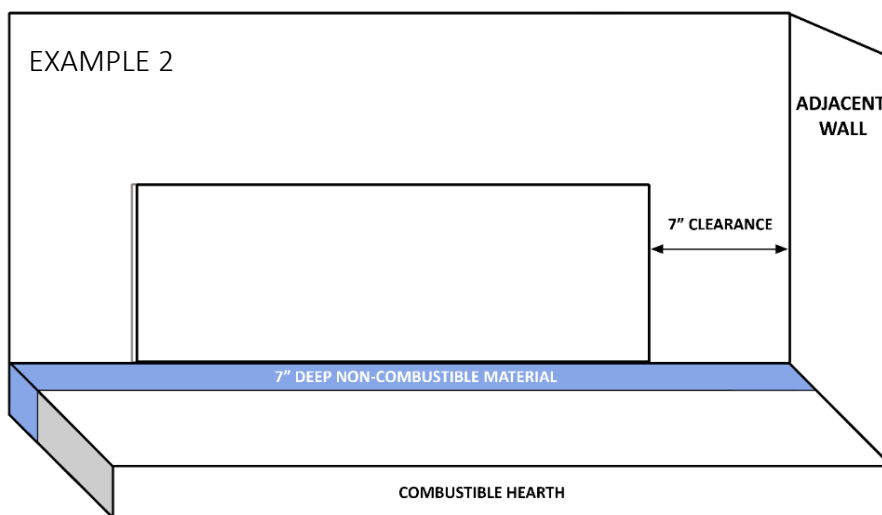
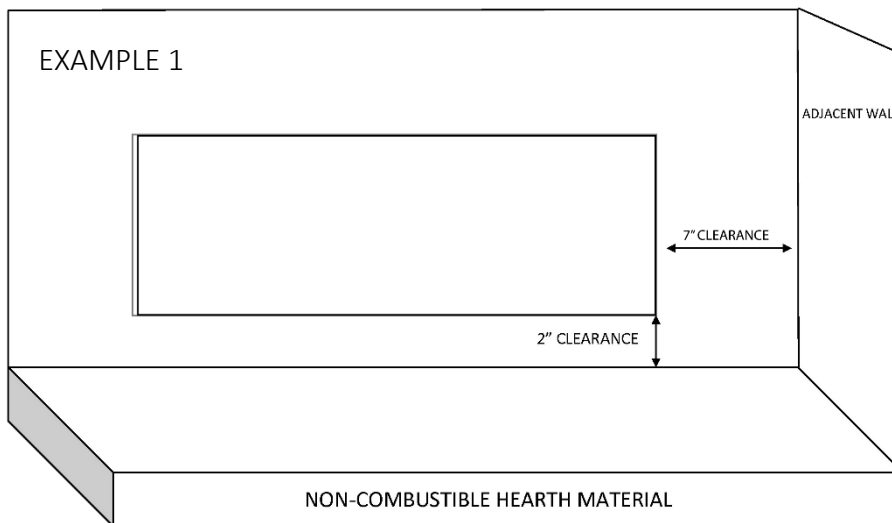

16. **Finishing Around Front of Fireplace – Top, Bottom, and Sides** - Non-combustible finishing material (i.e., cement board, brick, stone, tile & minimum ½” inch Type X fire rated drywall) **MUST** be used to finish around the front of the appliance. Covered combustible material can also be used to finish around the front of the fireplace, but only if the proper distance from the fireplace is maintained. Use the example below to find proper distance. See **Examples 1, 2, and 3** below for further details.

EXAMPLE 1

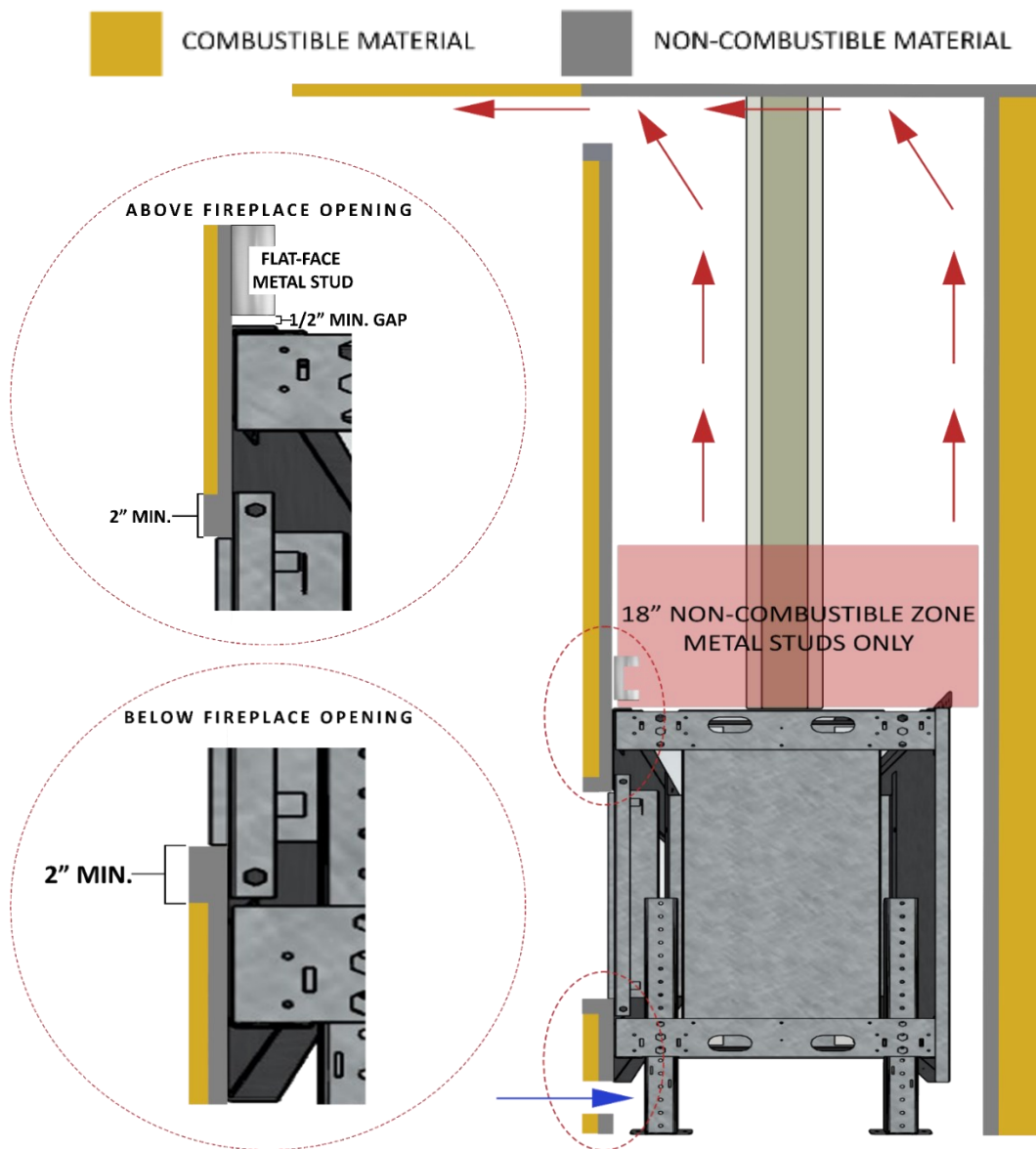

EXAMPLE 2

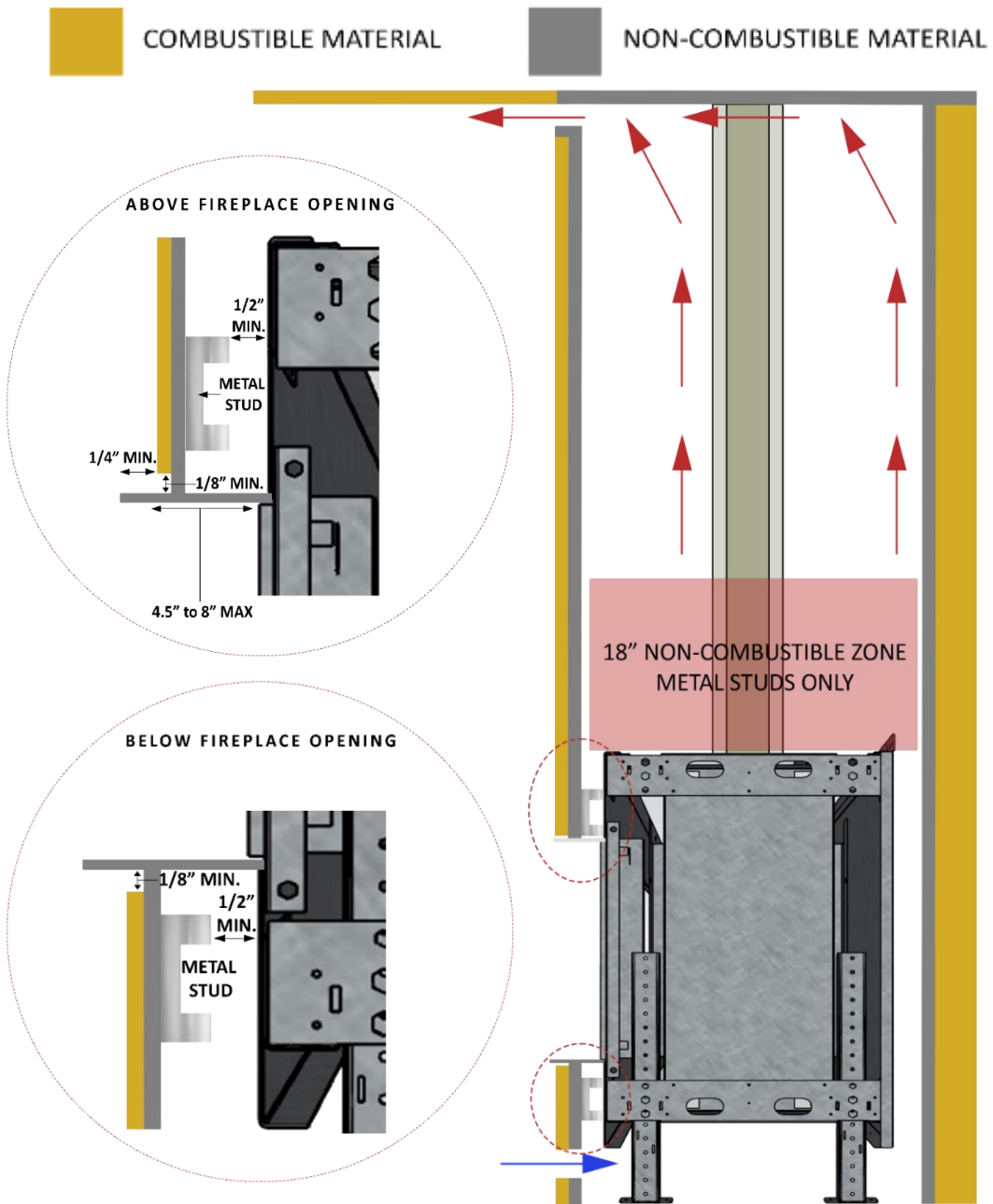

EXAMPLE 3

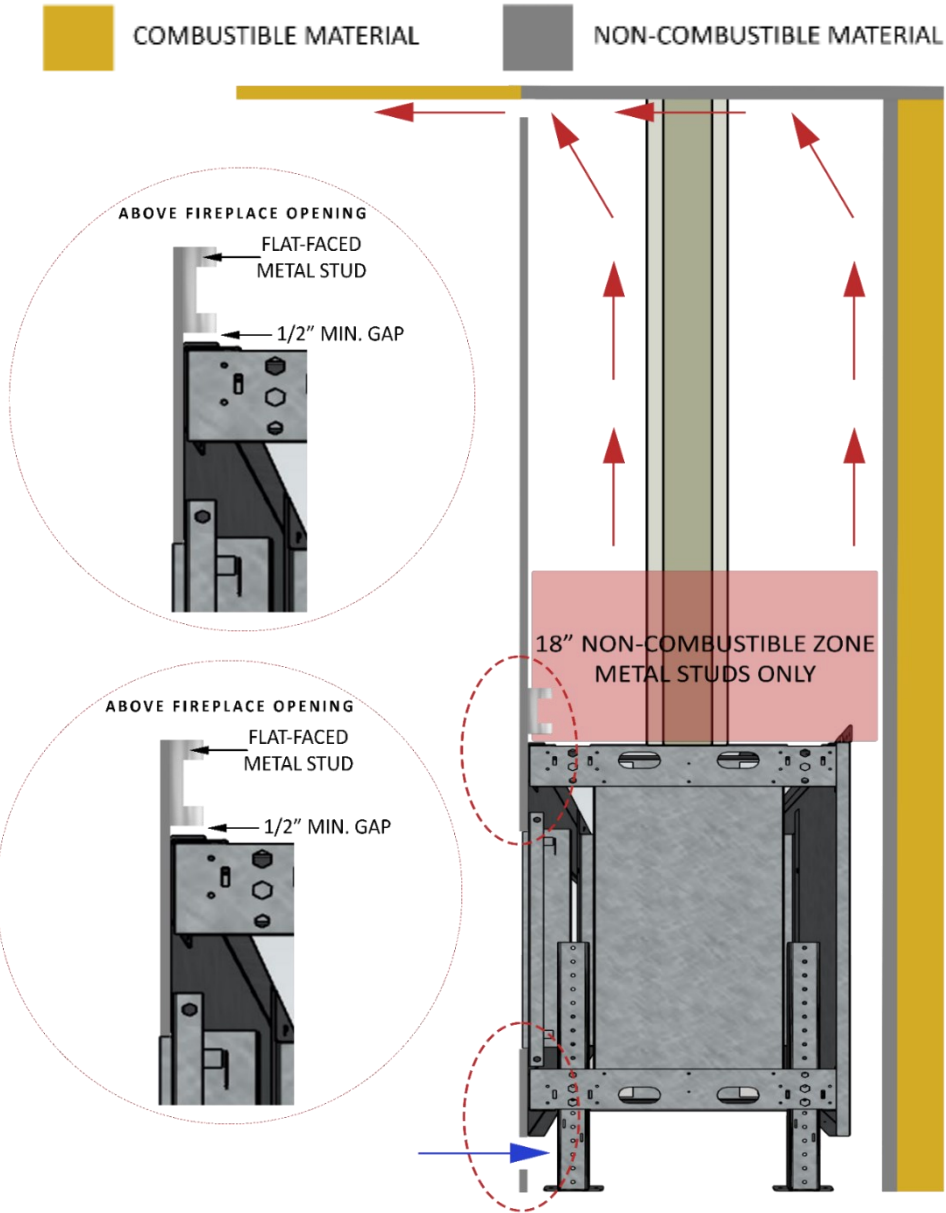

Note: Do not connect materials to or drill into the metal fireplace frame. This can result in excessive heat transfer and/or damage to the fireplace and surrounding materials.



CLEARANCES SPECIFICATIONS

Non-Combustible Materials Specification

Material which will not ignite and burn. Such materials are those consisting entirely of steel, iron, brick, tile, concrete, slate, glass or plasters, or any combination thereof. Materials that are reported as passing ASTM E 136, Standard Test Method for Behavior of Materials in a Vertical Tube Furnace at 750 °C shall be considered non-combustible materials. Non-combustible cement board approved must be at least 1/2" (13 mm) thick.

Non-combustible material may be installed on the fireplace frame to cover the metal part as detailed in the installation examples and clarifications only if there is no weight transfer to the fireplace. Facing and/or finishing materials must never overhang into the glass opening.

DO NOT connect materials to or drill into the metal fireplace frame. This can result in excessive heat transfer and/or damage to the fireplace and surrounding materials.

All joints between the finished wall sheathing and the appliance must be sealed with non-combustible materials.

WARNING! Risk of Fire! **DO NOT** apply combustible materials beyond the minimum clearances. Comply with all minimum clearances to combustibles as specified in this manual.

Examples of noncombustible materials to be used:

- Skamol Skamotec
- Promat PROMAFOUR System 1/2"/12 mm, 5/8"/15 mm, 3/4"/18 mm
- James Hardie - Hardiebacker® 1/2" Cement Board
- 1/2" or 5/8" Type X fire rated drywall. Type X gypsum board must comply with ASTM C1396 specification. Type X fire rated gypsum board can be used around the fireplace or at the back as a non-combustible material. **5/8" thickness is preferred because of better R-value.**

Combustible Materials Specification

Materials made of or surfaced with wood, compressed paper, plant fibers, plastics, or other material that can ignite and burn, whether flame-proofed or not, or plastered or un-plastered shall be considered combustible materials.

MANTEL CLEARANCES

Combustible mantel clearance can vary per mantel size and location. Use chart and provided table for information on mantel installation. Do not anchor any mantel or shelf to the fireplace. Only use metal studs above the fireplace as anchor points. Non-combustible mantels do not have a minimum clearance to the fireplace opening and can be brought as close to the glass as allowed by the frame of the fireplace. Please keep in mind any material used could potentially heat up dramatically the closer to the fireplace you bring it and the longer the fireplace is on.

MANTEL CLEARANCE TABLE AND EXAMPLE

REF	Height	Mantel Depth
A	2"	1"
B	4"	4"
C	6"	6"
D	10"	12"

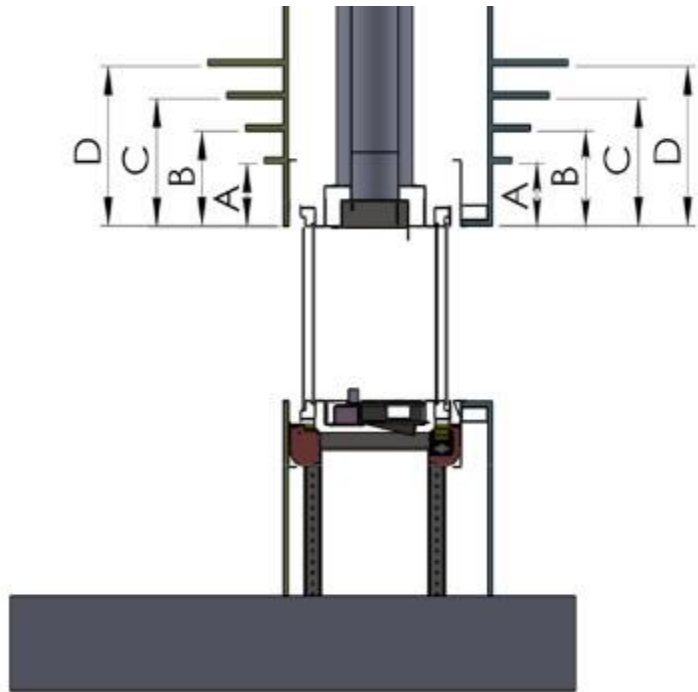

CLEARANCES TO SPRINKLER

In a situation where a sprinkler head is installed within proximity to a Heat Release, the diagram below **MUST** be followed. The distance between the sprinkler head & Heat Release opening cannot be less than 60" in length at every point from the origin of the Heat Release. You must also verify the sprinkler head sensor is set to the proper heat setting so it does not activate when the room heats up from the fireplace being operated normally. **DO NOT INSTALL A SPRINKLER IN THE FIREPLACE CAVITY.** Please follow the local building code to determine what temperature setting is relevant for your installation.

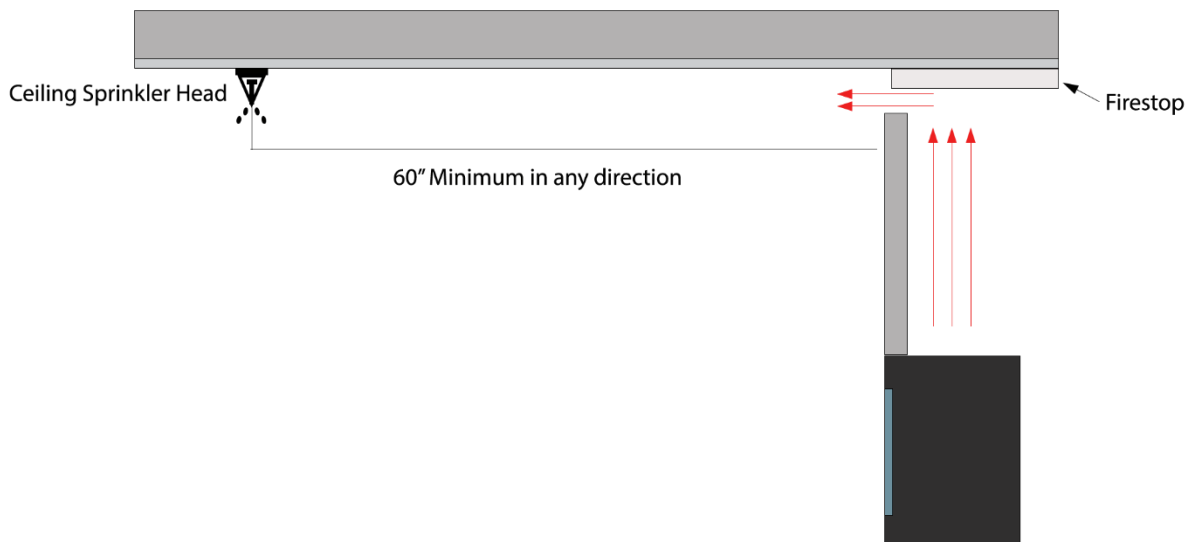

WARNING!

Vaulted ceilings can create a channel that funnels the hot air directly towards a sprinkler head placed at the proper distance from heat release, as stated above. If the sprinkler head sensor is not rated for high heat it could potentially set off the sprinkler system inadvertently. Please collaborate with the builder & inspector to verify your sprinkler system is properly set to accommodate higher temperatures & is not set up in a heat channel.



TRADITIONAL HEAT RELEASE OVERVIEW

The heat release opening is required for all traditional fireplaces and allows warm air to flow back into the room. This controls the temperature of the surrounding walls, keeping them relatively cool.

Heat Release Keys:

1. Must remain open at all times.
2. Must be at the top of the enclosure, within 1" – 3" of the non-combustible firestop.
3. Can be located on any interior side of the surround
4. If placed on the side of the surround it must be on both sides and sized equally
5. The heat release must be interior facing
6. The heat release must be horizontally oriented.
7. Restriction created by any finishing placed over the opening must be considered when calculating the open-air flow
8. All sizing is assuming the surround stops a minimum of 40" above the fireplace

Fireplaces sized **42"** & **46"** - vent area must be at least **140 square inches of open-air flow**.

Fireplaces sized **39"** - vent area must be at least **100 square inches of open-air flow**.

NOTE

Any opening greater than the minimum size is highly recommended and will help reduce the temperature of the surrounding walls. Make sure a non-combustible fire stop is placed atop the inside of the chase and is framed in a way that does not allow any pockets of heat to be formed. All heat should be able to rise to the fire stop and freely flow out of the heat release opening into the room.

TRADITIONAL HEAT RELEASE EXAMPLES

SHADOW LINE

The shadow line heat release is implemented by dropping your surround 1" – 3", recessing your build back 3" – 4" then finishing to the ceiling. This will create a small L-shaped reveal at ceiling level where the portion of the reveal running parallel to the ceiling is left open across the length and/or sides of the surround.



DROP WALL

The drop-wall heat release is implemented by creating a surround that reaches the minimum ceiling level of 40" above the top of the fireplace, and instead of bringing the surround all the way to the ceiling you hold your entire surround from the ceiling, opening the top of the surround to allow heat to rise out of the top and into the room.

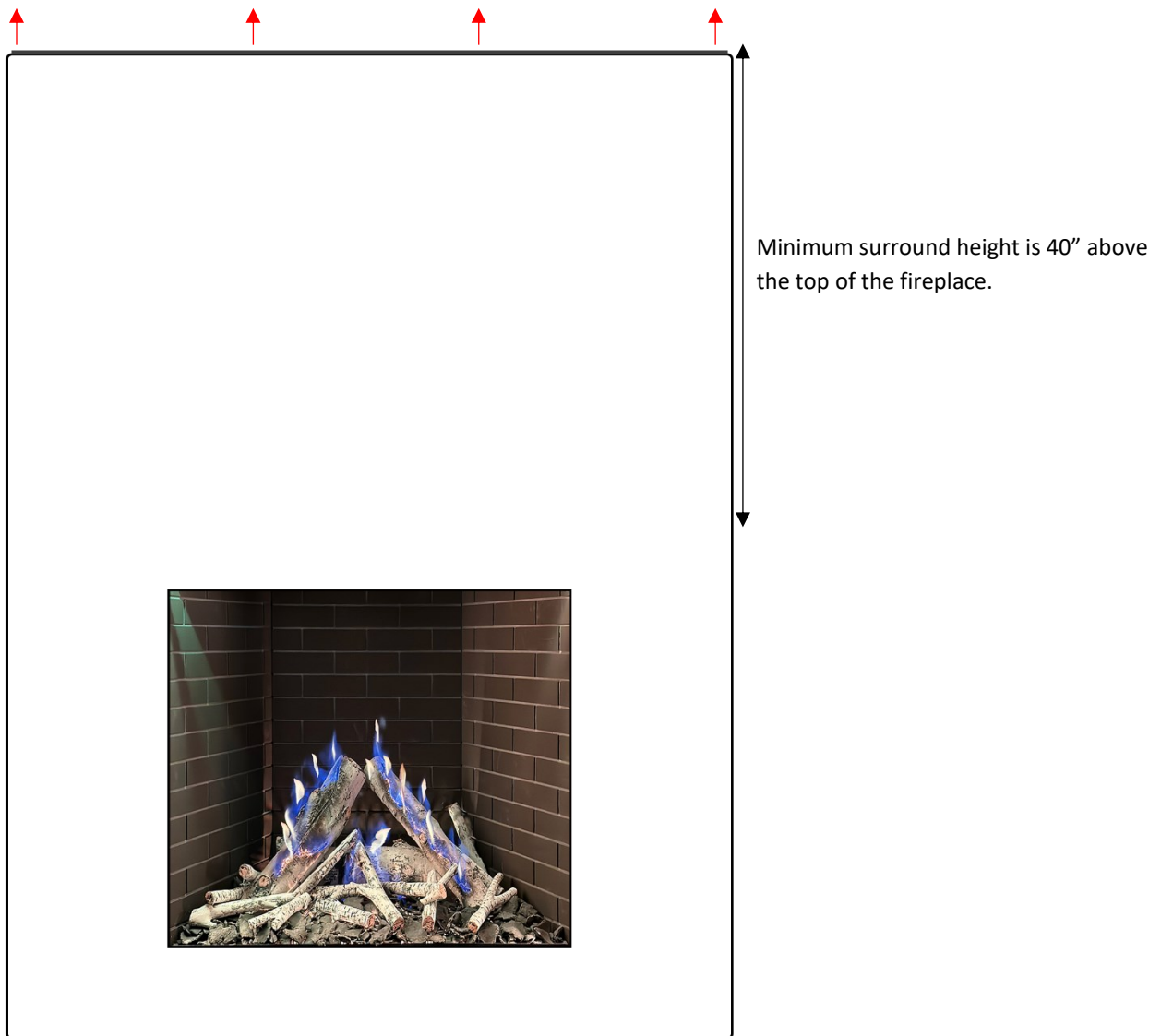

LINEAR SLOT OR LOUVERED GRATE

The linear slot or louvered grate heat release is implemented by creating an opening in your fireplace surround within 1" – 3" of the non-combustible firestop which meets the open air-flow requirements and allows the heat to enter the room through the opening provided.



NOTE

Once you understand we use natural air flow to cool the area around the fireplace, you'll see there are many ways to design an effective heat release. Our manual can't show every possibility, but if you have a design idea, please contact us. We're happy to approve it for you.



AIR INTAKE

Required for installation on cool glass systems. This allows air circulation which cools the external glass and increases the efficiency of the fireplace. The lower vent opening can be installed at any side of the enclosure.

For fireplaces sized **42" and 46"** - vent area must be at least **70 square inches OPEN AIR FLOW**.

For fireplaces sized **39"** - vent area must be at least **50 square inches OPEN AIR FLOW**.

[Air Intake Specification Manual](#)

NOTICE

*****Vertically oriented heat releases or air intakes are not acceptable and will lead to overheating*** all ventilation openings must be interior facing to avoid exposing the indoor fireplace and components to exterior elements.**

EXAMPLES OF AIR INTAKES

TOE-KICK REVEAL



*SIDE VENTS

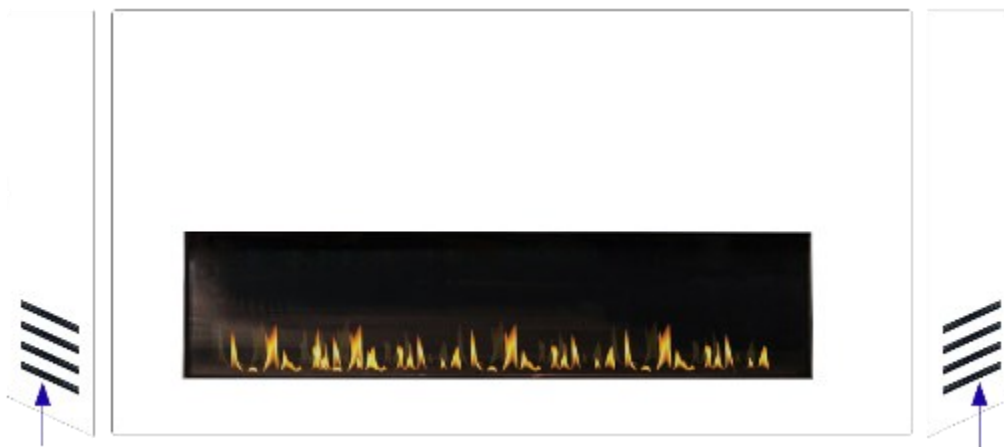

*Must be installed on both short sides of the cavity and balanced in size.

FLOATING HEARTH

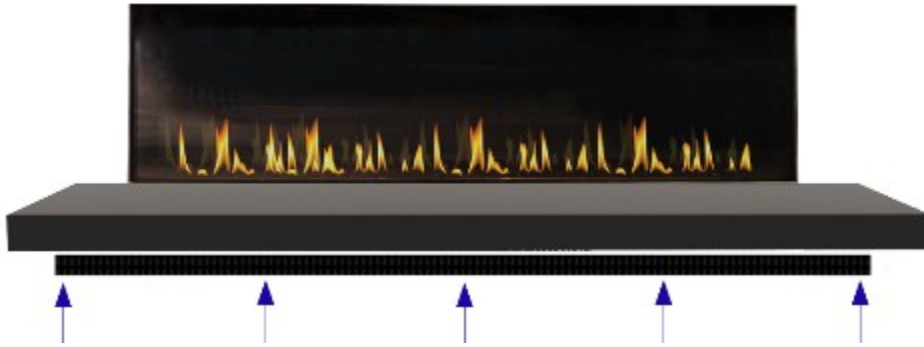

LINEAR SLOT



TRADITIONAL FIREPLACE CLEARANCE DETAILS

FLATE – SIDE AND ISOMETRIC VIEW

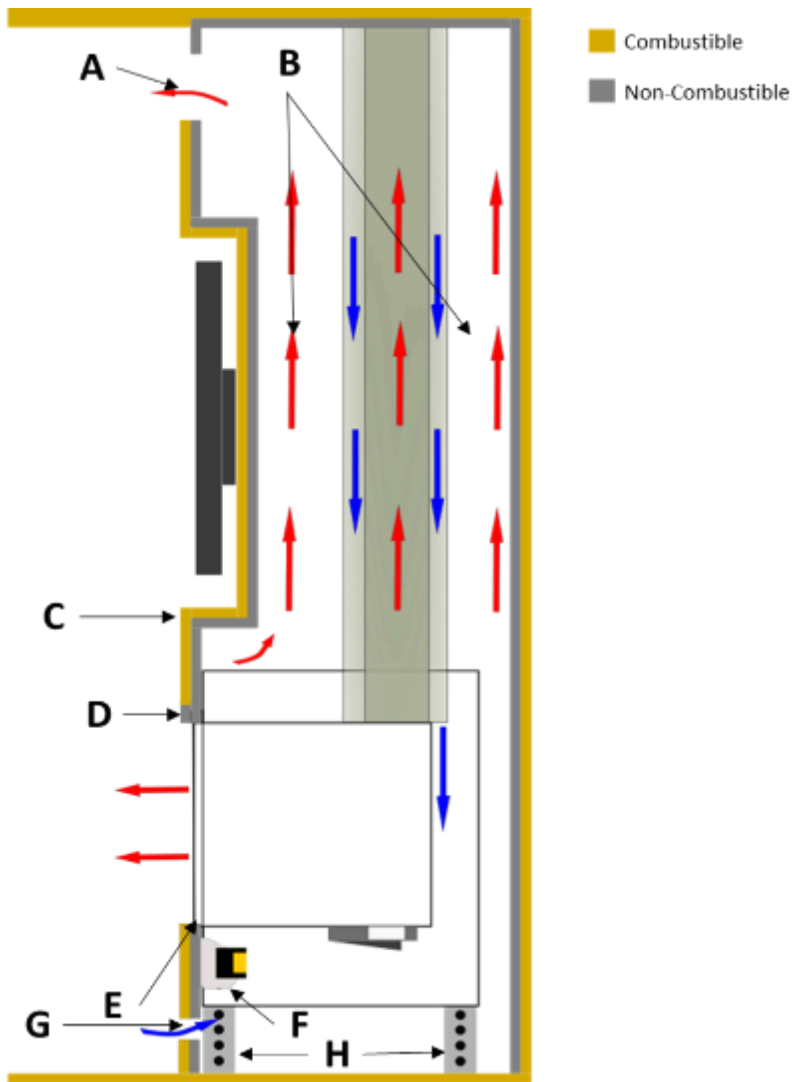

Warning! – Maintain open Air flow between the fireplace and drywall. Make sure cables or any other materials are not blocking hot air flow.



- A. Top Vent system - Hot Airflow outlet from the wall enclosure **MUST** remain open. For Flare See Through fireplace, open vent must exist in both sides of the glass. The outlet must be at the top part of the enclosure but not necessarily at the front if the measurements below are maintained.

Fireplaces sized **42" & 46"** - vent area must be at least **140 square inches OPEN AIR FLOW**.

Fireplaces sized **39"** - vent area must be at least **100 square inches OPEN AIR FLOW**.

- B. Open air flow for hot air to rise from the fireplace to the top of the enclosure. The enclosure can be supported by studs, but open-air flow **MUST** always be maintained. In case needed, insulation for electric wires or systems may be added but it is **important** to keep most of the air flow open. **Never place any insulation on the fireplace.**

- C. Metal Stud below non-combustible material line. Below the non-combustible line, all studs used should be metal type. No studs to be connected to the fireplace frame (1/2 Inch clearance). Open hot airflow **MUST** be maintained and should not be blocked. **Note: Max recess of TV cavity should not exceed 6". Recesses exceeding this dimension run the risk of creating a shelf and hindering air flow above unit, resulting in a wall that may overheat.**

- D. Non-combustible material is placed flat on the front fireplace support bracket. The support bracket holds the fire-rated, non-combustible, material and allows hot air to rise from the glass into the fireplace enclosure. Hot air is to be released into the room using the top static vent opening.

The fireplace enclosure must allow air to rise and circulate from the top of the fireplace glass (from lower vent opening), to be released back to the room from the top.

To increase heating, the enclosure should prevent hot air from being released to the attic by venting it back to the room using the static vent system (A).

Non-combustible stud **MUST NOT** be connected or drilled into the fireplace frame. Drilling into the fireplace frame can result in damage to the fireplace.

- E. Cold air, drafted from the room through the lower static vent, (G) flows up and is heated by the fireplace. The Cold air gap should remain open to allow air to flow up and exchange heat with the fireplace. The fireplace can be installed with double glazing glass system or safety screens. A blower system may be used to push cold air up (F).

- G. Lower vent opening. **Required** for normal installation.

For fireplaces sized **42" and 46"** - vent area must be at least **70 square inches OPEN AIR FLOW**.

For fireplaces sized **39"** - vent area must be at least **50 square inches OPEN AIR FLOW**.

- H. Adjustable fireplace legs.

L-SHAPE SIDE AND ISOMETRIC VIEW

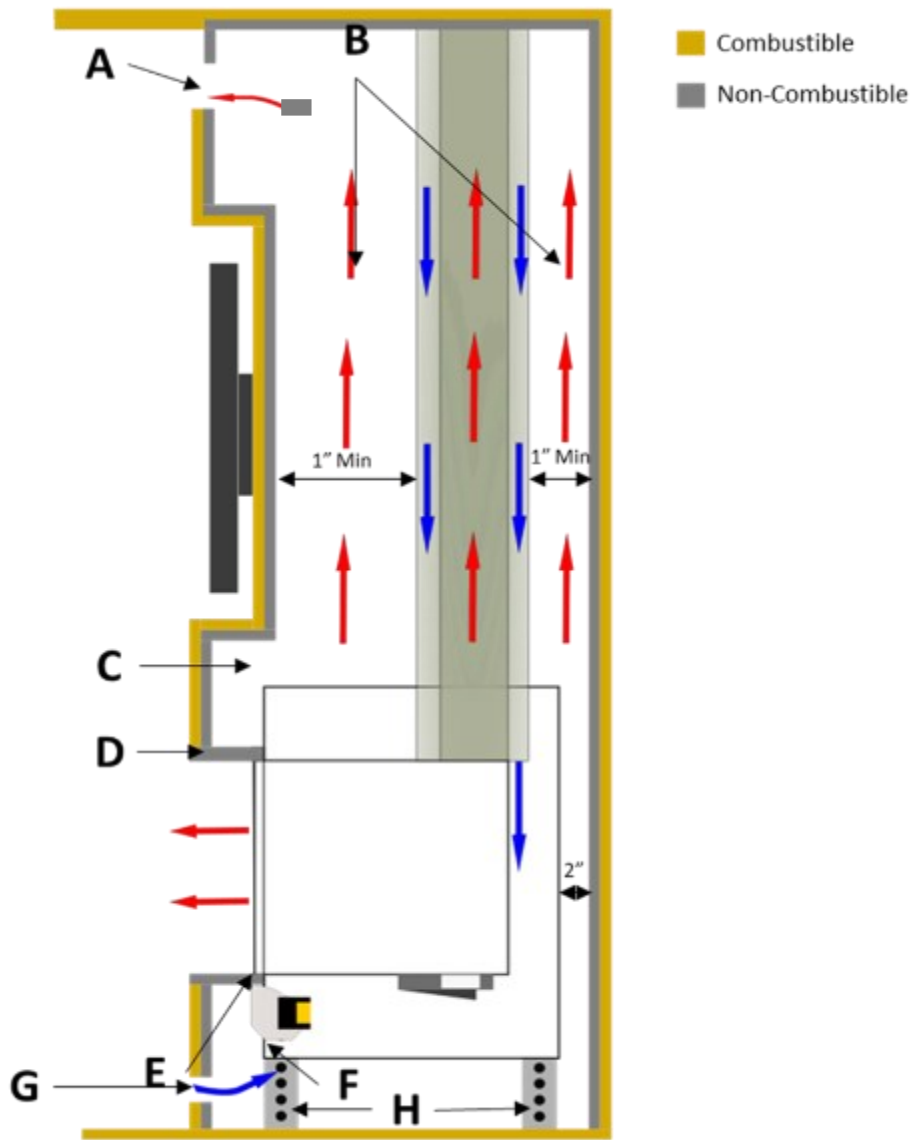

Warning! – Maintain open Air flow between the fireplace and drywall. Make sure cables or any other materials are not blocking hot air flow.



- A. Top Vent system - Hot Airflow outlet from the wall enclosure **MUST** remain open. For Flare See Through fireplace, open vent must exist in both sides of the glass. The outlet must be at the top part of the enclosure but not necessarily at the front if the measurements below are maintained.

Fireplaces sized **42" & 46"** - vent area must be at least **140 square inches OPEN AIR FLOW**.

Fireplaces sized **39"** - vent area must be at least **100 square inches OPEN AIR FLOW**.

- B. Open air flow for hot air to rise from the fireplace to the top of the enclosure. The enclosure can be supported by studs, but open-air flow **MUST** always be maintained. In case needed, insulation for electric wires or systems may be added but it is **important** to keep most of the air flow open. **Never place any insulation on the fireplace.**

- C. Metal Stud below non-combustible material line. Below the non-combustible line, all studs used should be metal type. No studs to be connected to the fireplace frame (1/2 Inch clearance). Open hot airflow **MUST** be maintained and should not be blocked. **Note: Max recess of TV cavity should not exceed 6". Recesses exceeding this dimension run the risk of creating a shelf and hindering air flow above unit, resulting in a wall that may overheat.**

- D. Non-combustible material is placed flat on the front fireplace support bracket. The support bracket holds the fire-rated, non-combustible, material and allows hot air to rise from the glass into the fireplace enclosure. Hot air is to be released into the room using the top static vent opening.

The fireplace enclosure must allow air to rise and circulate from the top of the fireplace glass (from lower vent opening), to be released back to the room from the top.

To increase heating, the enclosure should prevent hot air from being released to the attic by venting it back to the room using the static vent system (A).

Non-combustible stud **MUST NOT** be connected or drilled into the fireplace frame. Drilling into the fireplace frame can result in damage to the fireplace.

- E. Cold air, drafted from the room through the lower static vent, (G) flows up and is heated by the fireplace. The Cold air gap should remain open to allow air to flow up and exchange heat with the fireplace. The fireplace can be installed with double glazing glass system or safety screens. A blower system may be used to push cold air up (F).

- G. Lower vent opening. **Required** for normal installation.

For fireplaces sized **42" and 46"** - vent area must be at least **70 square inches OPEN AIR FLOW**.

For fireplaces sized **39"** - vent area must be at least **50 square inches OPEN AIR FLOW**.

- H. Adjustable fireplace legs.

HOME AUTOMATION

A Flare Fireplace can be operated through an external source (See cautionary remark below) such as a smart home (home automation) system by using the 6- pin connector on the SIT receiver **X8 port** in place of the included Wall Switch. The existing Flare Fireplace wall switch cable must be used to connect the receiver to the home automation system. The existing Flare Fireplace wall switch cable can be located by removing the included Flare Fireplaces wall switch, exposing the wire provided, and replacing it with a dry contact On/Off relay controlled by the home automation system. The existing Flare Fireplace wall switch cable can be extended up to 100 FT for integration into a new or existing Home Automation System. **Please contact Flare Support for additional information on appropriate relays to be used.**

1. The included Flare Fireplaces Wall Switch Can be seen in the example below

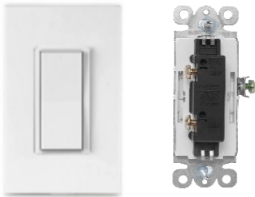

2. An example of the exposed wall switch with cables used to connect to dry contact On/Off relay can be seen below.

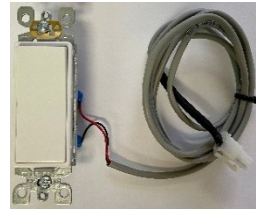

3. Remove the physical switch exposing your wires as seen below



4. Use exposed cables to connect your system to dry contact On/Off relay and tie into home automation or smart product.

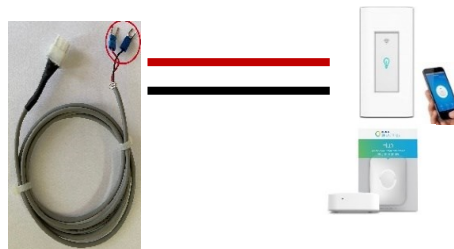

CAUTION

Do not control fireplace from outside of home using externally connected device. Only operate 3rd party application or home automation when you can physically see the fireplace turning on & off. It is not meant to operate without line of sight to fireplace

ELECTRIC AND CONTROL

ELECTRIC DIAGRAM

- Wall switch/Home Automation connects directly to **X8 port**.
- **X4 port** is always closed circuit.
- SIT 110v will be powered by home wall socket.

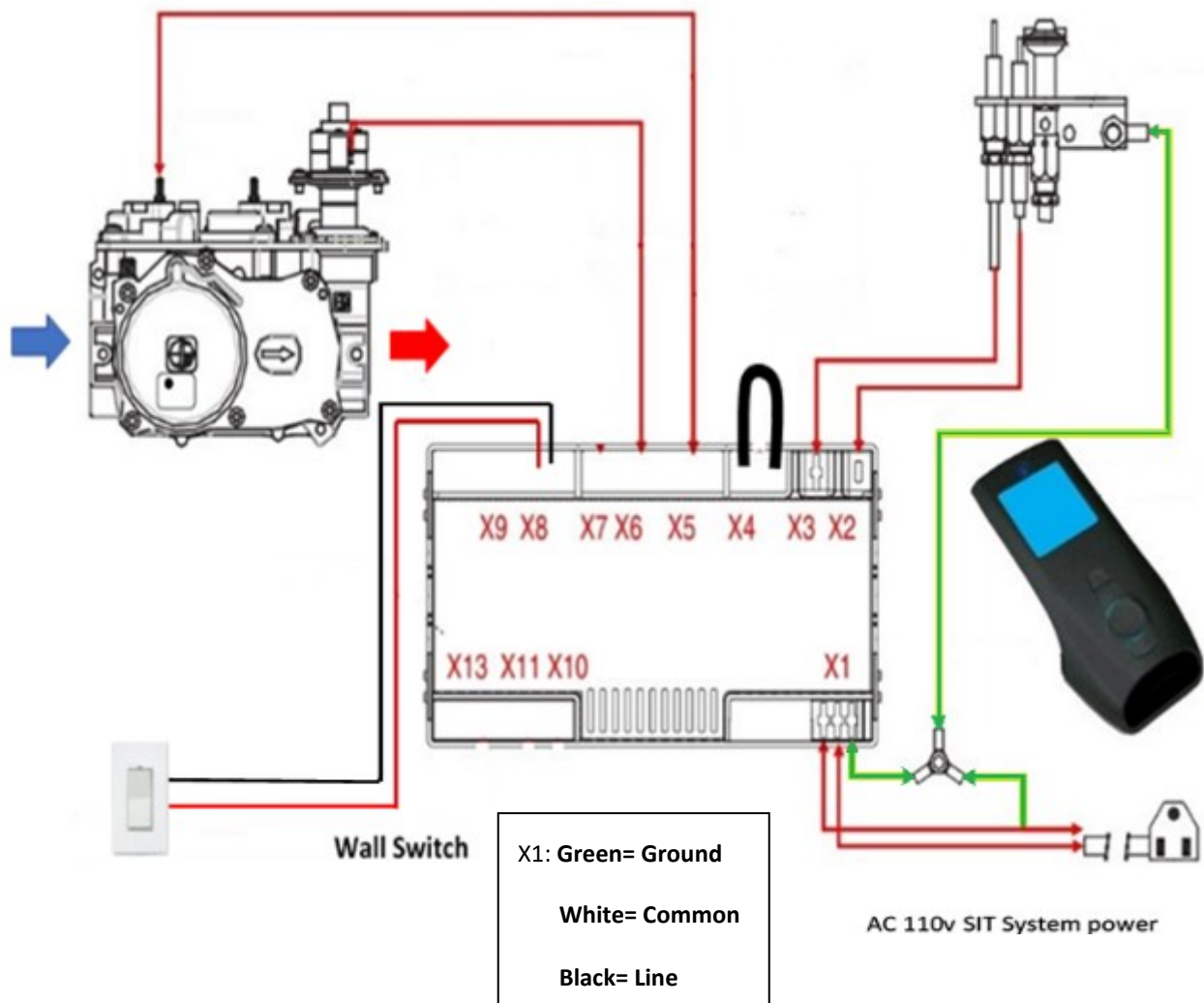

ELECTRIC DIAGRAM – INTERNAL PV SYSTEM

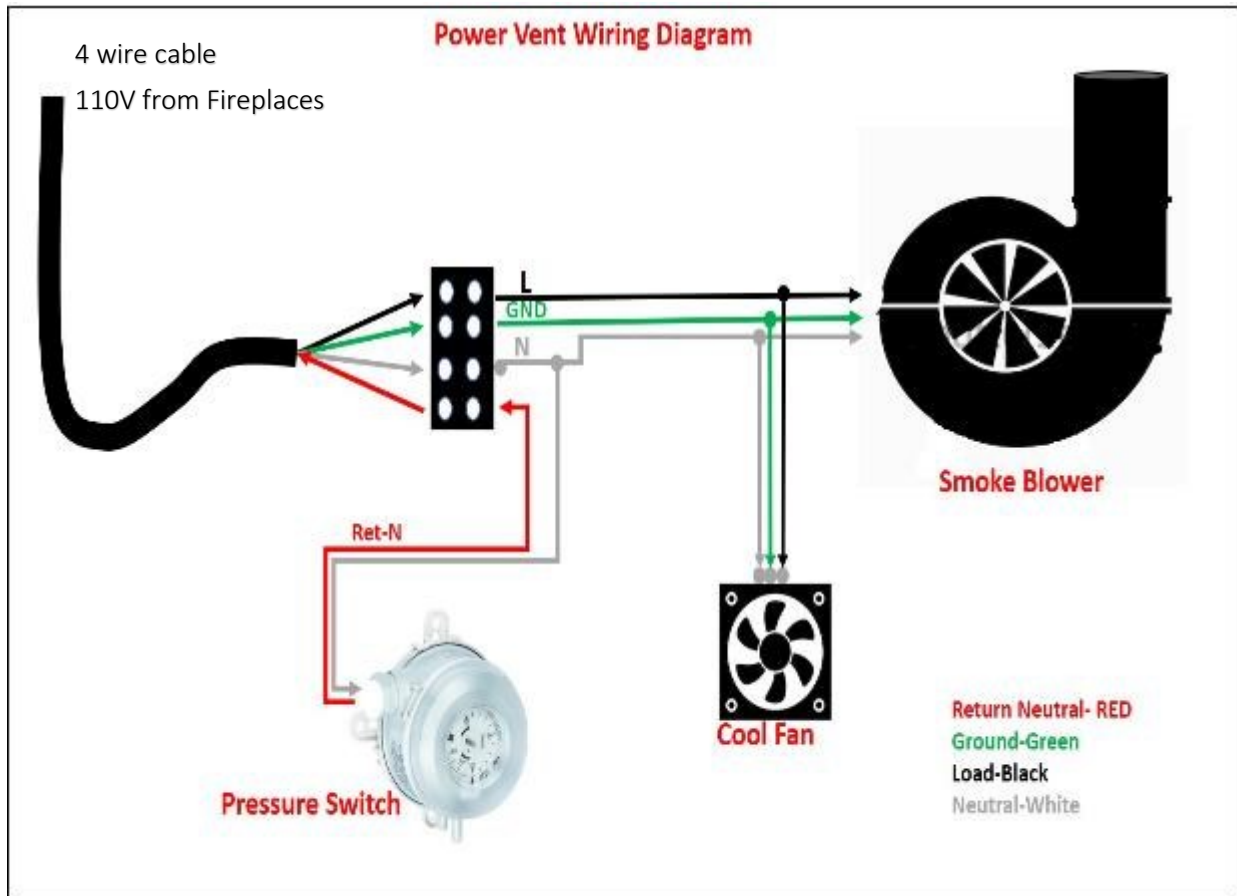



REPLACEMENT PARTS

See below for flare replacement part list. [Click for Traditional Fireplace Parts View and List](#)

- Please contact your fireplace dealer to purchase any replacement part.
- Please be sure to provide the description and part number.
- Please make sure to use a certified installer for any service related to your fireplace.

PART NAME	DESCRIPTION	SKU
SIT-Full Gas System	Gas Valve System, Receiver, SIT Wiring	1SITCGS
SIT-Valve NG	Natural Gas Valve for SIT System	1SITGVNG
SIT-Valve LP	Liquid Propane Gas Valve for SIT System	1SITGVLP
SIT-Remote	Remote for SIT System	1SITREM
SIT-Receiver	Receiver for SIT System	1SITREC
SIT-Wall Switch X-8	Wall Switch for Screened SIT System	1SITWS
SIT-Data X-5 Cable	Data Cable for SIT System	1SITX5DC
SIT- Ground Cable	Ground Cable for SIT System	1SITGC
SIT-LED Control	Cable to control LED Lights with SIT Module	1SITRGBC
SIT- 110 X-1 Cable	SIT Screen Adapter Wiring Harness	1SITX1
SIT-Pilot Assembly NG	Natural Gas Pilot assembly for SIT System	1SITPANG
SIT-Pilot Assembly LP	Liquid Propane Pilot Assembly for SIT System	1SITPALP
SIT - Pilot Orifice NG	Natural Gas Pilot Orifice	STPORNG
SIT- Pilot Orifice LP	Liquid Propane Pilot Orifice	STPORLP
SIT-Spark Cable	Ignition Cable for SIT System	1SITSC
SIT - Spark Ignitor Electrode	Electrode Used in Spark Ignitor	1SITPSP
SIT - Thermocouple	Brass Thermocouple Fitting for GV60 Valve	1SITPTH
SIT - Thermocouple Line	Metal Thermocouple Line	1SITPTHL
SIT - Pilot Gas Line	Metal Pilot Tube	1SITPPT
SIT-NG Motor	Natural Gas Motor for SIT Gas Valve	1SITNGMT
SIT-LP Motor	Liquid Propane Motor for SIT Gas Valve	1SITLPMT
SIT-Jumper x-4	Relay Jumper for SIT System	1SITJUMP
SIT Pilot Brass Compression Fitting	Brass Pilot Compression Fitting for SIT System	1SITBRASS
LED Power Supply	24V DC power supply	1RGBPS
LED Wiring Harness	Y-shaped wiring harness from LED strips to controller	1RGBYC
RBG LED Controller	RGB Controller and Remote	1RGBCR
RGB LED Strip	RGB LED Light Strip	1RGBLS
Narrow Glass Gasket	3/8" Wide	NGAS38
Wide Glass Gasket	5/8" Wide	NGAS58
Triple Glass Board	Used to power PV or SK on a Screen system	Triple Glass board
PV-Cable	PV 4-Wire Board Cable V5 (Pigtail for Flare Board)	PVCBL
Control SK Cable	SK 3-Wire Cable V5 (Pigtail for Flare Board)	1SKDGC
PVSK-Cable	PV/SK 5-Wire Cable V5 (Pigtail for Flare Board)	PVSKCBL
PV High Voltage Armored Cable	Per Foot - Metal Wrapped High Voltage 14 4 Power Vent Cable	PVCBLHV
SK High Voltage Armored Cable	Per Foot - Metal Wrapped High Voltage 14 4 Power Vent Cable	SKCBLHV
Gas Flex Line-Long	1/2" Gas Flex Line	10GFLL
Gas Flex Line-Long	3/8" Gas Flex Line	10GFLS
Threaded Leveling Feet	Threaded Leveling Feet Used To Level Direct Vent Fireplaces	THREADFT
Touch-Up Paint	Matte Black High-Temp SensoTherm Paint	TPPAINT



MAINTENANCE

WARNING!

- It is recommended that a qualified service technician perform a routine inspection at the beginning of each heating season.
- Disconnect power before attempting maintenance or repair of the fireplace.
- Installation and maintenance must be performed by an authorized qualified installer, service agency or gas supplier.
- Any safety screen or guard removed for servicing should be placed in the back before operating this appliance.
- DO NOT USE this appliance if any part has been under water. Immediately call a qualified service technician to inspect the unit and to replace any part of the control system and any gas valve that has been under water or impacted.
- Any alteration to the product that causes soot or carbon to form and results in damage is not the responsibility of the manufacturer.
- Do not modify or substitute any part of this appliance.
- Inspect the external vent cap on a regular basis to make sure that no debris, plants, trees, or shrubs are interfering with the air flow.
- Do not operate the fireplace without the fireplace glass.
- It is imperative that control compartments, screens, or fans system for double glass be kept clean and free of obstructions. These areas provide the air necessary for safe operation.
- Light the heater using the built-in igniter. Do not use matches or any other external device to light your heater.
- Never remove, replace, modify, or substitute any part of the heater unless instructions are given in this manual. A trained technician must do all the other work. Do not modify or replace orifices.



YEARLY SERVICE

Commercial fireplaces may need to be serviced more frequently depending on usage. Failure to inspect and maintain the fireplace may lead to improper combustion and a potentially dangerous situation. We recommend the following procedures be done by a qualified technician.

Glass Maintenance

- Always use suction cups to remove the fireplace glass. Use the manual procedure for instructions on how to remove the fireplace glass. Always use gloves when removing the glass to protect your hand and prevent fingerprints on the glass.
- **Do not use** abrasive cleaners on the glass panels. **Do not attempt** to clean the glass panels when they are hot.
- Do not use normal household (usually ammonia-based) glass cleaners to clean the glass as these cleaners can leave a permanent stain. Only a gas fireplace glass cleaner should be used.
- Verify no cracks or breakage in the glass.
- Place glass in a safe location to prevent breakage.
- Never attempt to operate the fireplace without the fireplace glass.

Pilot Maintenance

- Visually inspect the pilot flame. The pilot flame should always be present when the fireplace is in operation.
- Make sure the pilot flame has two flame tips pointing to the flame sensor (thermocouple) and to the center of the burner.
- Make sure the pilot area is clean from any dust, media or any other debris that may disrupt the operation of the ignition system. Lint or foreign material must be removed with a brush or vacuum.
- Verify fireplace ignition using the remote or wall switch. Verify electronic ignition, sparking sequence, pilot operation and burner ignition.

Burner Maintenance

- The flames from the burner should be visually checked. The flame should have a blue base and yellow tops and be candle-like in appearance.
- If excessive soot is found inside the firebox area, the fireplace will require adjustment. Verify the air shutter and vent restrictor setting and document any changes.
- If the flame becomes sooty, dark orange in color, or extremely tall, do not operate the heater.
- Measure gas pressure. Inlet _____ W.C., Outlet _____ W.C.

Vent Maintenance

- The following venting system inspection by a qualified service technician is recommended every six months:
- Inspect for excessive condensation, e.g., water droplets forming in the inner lining and subsequently dripping out of the joints. This can cause corrosion in the system.
- Check for corrosion in areas exposed to the elements. Where rust spots or holes have appeared, these must be immediately replaced.
- Ensure that there is no foreign material in the vents. Survey by removing the cap and shining a light down the vent.
- Check all joints and pipes to make sure that nothing has been disturbed or loosened.

Double Glass Fans

- Disconnect power to the Flare control system.
- Remove the external glass and the covering trim.
- Inspect the fans around the Flare firebox and make sure they are all turning.
- Clean all fans with a brush and vacuum to remove any dust or debris.
- Inspect the lower fireplace intake. Clean the lower vent intake with a brush and vacuum any dust or debris.
- Connect back the Flare control power and press the Flare remote arrow down. Make sure all fans are working properly.
- Turn off the fans and install back the trim and glass.



APPENDIX

MAINTENANCE

Flare Fireplaces – Maintenance log

The service technician should use the following document. A copy should be kept with the technician and owner for future reference.

Service Date: _____

Unit Information

Model Type and Size: _____

Serial #: _____

Owner Information

Name: _____

Address _____

Technician Information

Name: _____

Company Name _____

Technician NPI # _____

Service Information

Yearly Maintenance: _____

Other: _____

Details: _____



WARRANTY POLICY

Flare Fireplaces subjects every fireplace and component to rigorous testing to verify it is free from any defects before it leaves our warehouse. Flare Fireplaces photographs and documents the fireplace and all components' moments before shipping them to our nationwide network of authorized dealers for installation, verifying full operation of the fireplace and all components. Our factory is supervised by CSA and subject to the highest operating standards.

18 MONTH COMPREHENSIVE WARRANTY

Effective beginning 18 months from the **original date of purchase from an authorized Flare Fireplaces Dealer**, our Comprehensive Warranty includes replacing or repairing any defective electronic components. These parts include the following components:

- Gas Valve
- Receiver
- Remote
- LED Lighting Strips, Remote, & Controller
- Authorized Media
- Wall Switch

This warranty does not apply to any component that shows evidence of misuse, abuse, improper installation, exposure to water or moisture, excessive heat, dust, or paint.

LIMITED FIVE-YEAR COVERAGE

Effective for five years from the **original date of purchase**, Flare Fireplaces Limited Five-Year Coverage includes replacing both ceramic and tempered glass. This coverage is warrantable under the following circumstances:

- Thermal Breakage Only

This coverage is void if the glass is damaged due to construction, improper storage, pitting, transport, handling, or cleaning. This includes using ammonia or detergent based cleaning-solvents or solutions instead of lukewarm water and a lint free cloth. Other products may leave streaking or a honeycomb shaped stain on your fireplace glass.

LIMITED 10-YEAR COVERAGE

Limited Lifetime Coverage is extended to the following components:

- Firebox
- Burners



CONDITIONS

- **Warranty coverage begins on the date of original purchase.**
- Minor warping of certain components or discoloration is normal and is not considered a defect that is covered under this warranty. Major disruption and buckling of parts can be caused by over-firing of your fireplace. Over-firing above the rated value specified in the manual is contrary to the manufacturer's instructions and may void this warranty.
- All installations must be performed by a qualified technician in accordance with applicable local and national requirements.
- Installations must be done in accordance with the Flare Fireplaces installation manual. The Limited Warranty applies only if the product is installed in the United States or Canada and only if installed, operated, and maintained in accordance with the attached product manual.
- It is the responsibility of the installer to ensure the appliance is firing per the rating plate.
- Any part that is found in our judgment to be defective shall be repaired, replaced, or refunded at Flare Fireplaces' option.
- This warranty only covers appliances that are purchased through a Flare Fireplaces authorized dealer or distributor.
- The warranty is only valid while the appliance remains at the site of original installation.
- Flare Fireplaces does not install or provide installation services. The installation of the fireplaces must be done by an authorized installer. The fireplace's limited warranty does not cover the installation service, or any part related to the installation of the fireplace or surroundings of the fireplace and venting.
- **Contact your dealer for a warranty service.** If the dealer is unable to provide necessary parts, contact the nearest Flare Fireplaces authorized dealer or supplier.

EXCLUSIONS

- This warranty does not apply to any component that shows evidence of misuse, abuse, improper installation, accident, or lack of maintenance.
- Flare Fireplaces is not responsible for televisions, mantels, surroundings or finishing material around the fireplace.
- Flare Fireplaces is not responsible for installation, operational or environmental conditions beyond our control.
- Flare Fireplaces shall in no event be liable for any special, indirect, or consequential damages of any nature which are more than the original purchase price of the product.
- Flare Fireplaces may at its discretion discharge all obligations by refunding the wholesale price of the defective part.
- This warranty may not be extended or modified by our dealers or representatives.
- The Limited Warranty only covers parts and labor as provided above. Flare Fireplaces will not be responsible for materials, components, or construction, which are not manufactured or supplied by Flare Fireplaces or for the labor necessary to install, repair or remove such materials, components, or construction.



WARRANTY VOIDED WHEN

- An unauthorized media type is used in the firebox.
- The appliance has been over-fired or operated in atmospheres contaminated by chlorine, fluorine, or other damaging chemicals. Over-firing can be identified by, but not limited to, warped plates or pipes, rust colored iron or bubbling, cracking and discoloration of steel or enamel finishes.
- The appliance is subjected to prolonged periods of moisture or condensation.
- There is any damage to the appliance or other components due to water or weather damage, which is the result of, but not limited to, improper chimney or venting installation.
- Holes have been drilled into the fireplace for some reason.