

# ELEMENT



## Installation, Operation and Owner's Manual

### Sky LR, MR, SR

### Direct Vent Gas Fireplaces

## **DANGER**

**HOT GLASS WILL  
CAUSE BURNS.  
DO NOT TOUCH GLASS  
UNTIL COOLED.  
NEVER ALLOW CHILDREN  
TO TOUCH GLASS.**



Une surface vitrée chaude  
peut causer des brûlures.  
Laisser refroidir la surface  
vitrée avant d'y toucher.  
Ne permettez jamais à un enfant  
de toucher la surface vitrée.

A barrier designed to reduce the risk of burns from the hot viewing glass is provided with this appliance and shall be installed for the protection of children and other at-risk individuals.

Une barrière conçu pour réduire le risque de brûlure par le verre de visualisation chaude est fournie avec cet appareil et doit être installé pour la protection des enfants et autres personnes à risque.

### **WARNING:**

**FIRE OR EXPLOSION HAZARD**  
Failure to follow safety warnings exactly could  
result in serious injury, death, or property damage.

- Do not store or use gasoline or other flammable vapors and liquids in the vicinity of this or any other appliance.
- **WHAT TO DO IF YOU SMELL GAS**
  - Do not try to light any appliance.
  - Do not touch any electrical switch; do not use any phone in your building.
  - Leave the building immediately.
  - Immediately call your gas supplier from a neighbor's phone. Follow the gas supplier's instructions.
  - If you cannot reach your gas supplier, call the fire department.
- Installation and service must be performed by a qualified installer, service agency or the gas supplier.

### **AVERTISSEMENT:**

**INCENDIE OU D'EXPLOSION**  
Le non-respect des avertissements de sécurité à la lettre pourrait entraîner de graves blessures, la mort ou des dommages matériels.

- Ne pas entreposer ni utiliser d'essence ni d'autres vapeurs ou liquides inflammables dans le voisinage de cet appareil ou de tout autre appareil.
- **QUE FAIRE SI VOUS SENTEZ UNE ODEUR DE GAZ**
  - Ne pas tenter d'allumer d'appareil.
  - Ne touchez à aucun interrupteur. Ne pas vous servir des téléphones se trouvant dans le bâtiment ou vous trouvez.
  - Quitter immédiatement le bâtiment.
  - Appelez immédiatement votre fournisseur de gaz depuis un voisin. Suivez les instructions du fournisseur.
  - Si vous ne pouvez rejoindre le fournisseur de gaz appelez le service des incendies.
- Installation et l'entretien doivent être effectués par un installateur qualifié, une agence de service ou le fournisseur de gaz.

**INSTALLER:** Leave this manual with the appliance.  
**CONSUMER:** Retain this manual for future reference.

**INSTALLATEUR:** Laissez cette notice avec l'appareil.  
**CONSOMMATEUR:** Conservez cette notice pour consultation ultérieure.



# CONTENTS

<b>1 DECLARATION OF PERFORMANCE</b>	<b>4</b>
<b>2 IMPORTANT INFORMATION</b>	<b>4</b>
2.1 Fuel type	4
2.2 Installation	4
2.3 Other information	5
2.4 Packaging materials	5
<b>3 SAFETY INFORMATION AND WARNINGS</b>	<b>5</b>
<b>4 THE CONTROLS</b>	<b>8</b>
4.1 Electronic ignition	8
<b>5 GAS INSTALLATION</b>	<b>10</b>
5.1 Attention points gas fireplace	10
5.2 Attention points gas connection	10
5.3 Checking the gas lines	10
5.4 Installing the gas line	10
<b>6 FIRE SAFE INSTALLATION</b>	<b>11</b>
6.1 Fire safety device set-up	11
6.2 Place of installation	11
6.3 Temperature	11
6.4 Assembly regulations	13
<b>7 ENCLOSING THE FIREPLACE</b>	<b>15</b>
7.1 Hot air outlets and ventilation grilles	15
7.2 Clearances (overview)	16
7.3 Decorating the enclosure	16
7.4 Fire specific dimensions	17
7.5 Roomdivider installation guidelines	18
<b>8 VENTING REQUIREMENTS</b>	<b>19</b>
8.1 General safety rules regarding venting material	19
8.2 Installation of venting material	19
8.3 Determining the vent gas extraction diameter	20
<b>9 VENT CALCULATION TABLE</b>	<b>22</b>
9.1 Horizontal termination	22
9.2 Vertical termination vent diameter	23
<b>10 VENT TERMINATIONS</b>	<b>25</b>
10.1 Vertical Terminations - clearances and requirements	25
10.2 Horizontal terminations - clearances and requirements	26
<b>11 MAINTENANCE INSTRUCTION</b>	<b>28</b>
11.1 Maintenance in the combustion chamber	28
11.2 Glass Maintenance	31
11.3 Burner Maintenance	32
<b>12 INSTALLING THE FIRE MEDIA</b>	<b>33</b>
<b>13 TECHNICAL DATA</b>	<b>35</b>
13.1 Gas specifications	35
13.2 Electric Specification	35
<b>14 OPERATING THE FIREPLACE</b>	<b>36</b>
14.1 Before the first fire	36
14.2 The first fire	36
14.3 The first fire - testing	36
<b>15 ELECTRONICS</b>	<b>37</b>
15.1 Electrical requirements	37
15.2 (Replacement) parts	37
15.3 Remote control	38
15.4 Element4 ProControl App.	43
15.5 Connecting to a smart home system	44
<b>A MASSACHUSETTS CERTIFICATION</b>	<b>45</b>
<b>B TROUBLESHOOTING FLOWCHART</b>	<b>46</b>
<b>C ERRORS CODES PROCONTROL APP</b>	<b>50</b>
C.1 Messages shown in app	50
C.2 Messages shown in remote	51
<b>D DIMENSIONAL DRAWINGS</b>	<b>52</b>
<b>E SPARE PARTS</b>	<b>55</b>
<b>F ELEMENT4 WARRANTY</b>	<b>57</b>



## 1 DECLARATION OF PERFORMANCE

We hereby declare that the design and construction of the Element4 gas appliances are complying to the essential demands and regulations for gas products.

Product:

- Direct vent gas fireplace, local spaceheater

Model:

E4-36

- Sky LRD

E4-37

- Sky MRD

E4-38

- Sky SRD

Applicable guidelines and norms:

- ANSI Z21.11.50a-2008
- CAN/CGA 2.17 - M91
- CSA2.22a-2008 "Vented Gas Fireplaces"

This declaration loses its validity when changes to the device are made without the written permission of Element4. You can ask for a copy of the test certificates of all models via our general e-mail address, which is found on the back of this manual.



J. Kempers  
CEO

## 2 IMPORTANT INFORMATION

### Installer

Leave the following for the customer and explain when necessary

- User manual
- Installation manual
- Instruction card decoration media
- Suction cups
- Remote control

### Owner

Keep this manual for future reference

The fireplace may only be installed by a qualified installer/dealer, following these installation instructions. We advise you to read these instructions properly, before commencing the installation of your device. Make yourself fully aware of all the following instructions and the many features of your Element4 direct vent gas fireplace appliance.

Before installation check the device for transport damage and inform your supplier immediately if damage is found.

This appliance is a vented gas fireplace. It must not be used for any other purposes such as drying clothes, etc.

### 2.1 Fuel type

This device is designed to be used with natural gas or LPG. The device can only be used with the type of gas specified on the data plate at the time of purchase. This unit is not for use with solid fuels.

The gas type and pressure should check out with those locally available. The data plate is mounted to the device. Make sure it is accessible at all times. See **CHAPTER 13** for more elaborate specifications on your fireplace.

### 2.2 Installation

This direct vent system appliance must be installed as an OEM installation in manufactured homes (USA only) or an aftermarket permanently located, or a mobile home, where not prohibited by local codes and must be installed in accordance with Manufacturer's instructions and the Manufactured Home Construction and Safety Standard, Title 24 CFR, Part 3280, in the United States, or the Standard for Installation in Mobile Homes, CAN/CSA Z240 MH Series, in Canada.

These direct vent appliances must be electrically grounded in accordance with the local codes or, in the absence of local codes, with National Electric code, ANSI/NFPA 70, or the Canadian Electric Code, CSA C22.1. More in the electronics and gas parts of the fireplace in **CHAPTER 4** and **CHAPTER 15** of this manual.

If your installation is at an elevation greater than 2000' in the US or 4500' in Canada, consult with the local authority having jurisdiction for gas product installations to determine their specific requirements for high altitude installations.

## 2.3 Other information

The heat that is coming from the device may effect the materials in its surroundings. Always install the fire taking into account to correct the safety distances. For more information see **CHAPTER 7.2**.

The device may never be used without the glass or when glass is broken. The flue gases can get into the fireplace chase. The settings and construction of the device must not be changed! For maintenance and further handling of the fire see **CHAPTER 11.2** and **CHAPTER 11.3**

The device is provided with a special set of decorative media. Do not place any extra imitation logs or decoration media on the burner or in the combustion chamber. See **CHAPTER 12** for an instruction on how to arrange the decoration media properly.

## 2.4 Packaging materials

The packaging of the device is recyclable.

The following packaging materials may have been used:

- Cardboard
- CFC-free foam (soft)
- Wood
- Plastic
- Paper

These materials must be disposed of in a responsible manner and in accordance with government regulations.

Batteries are regarded as chemical waste. The batteries must be disposed of in a responsible manner and in accordance with government regulations. Remove the batteries first before discarding the remote control.

The government can also provide information about the responsible disposal of discarded appliances.

## 3 SAFETY INFORMATION AND WARNINGS

If the information in these instructions is not followed exactly a fire or explosion may result causing property damage, personal injury or death.

**Note:** This device may not be used a primary heat source!

Do not use this appliance as a temporary source of heat during construction.

### 3.4.1 Replacement or spare parts

Parts are only to be changed with original parts by the original manufacturer.

If parts need to be replaced , use only original parts from the manufacturer. The warranty (**APPENDIX F**) will be void if non-standard parts re used.

Dimensions will appear as Inches / metric throughout this manual. For convenience, the inches are rounded to the nearest 1/16” when converted. If greater accuracy is required, use the metric dimensions.

### 3.4.2 Children and pets

Radiant heat can heat surfaces such as the surround and trims of the fireplace to temperatures that, although approved safe, can be quite uncomfortable to touch - particularly for children and pets.

Children and pets should always be supervised when in the room where the appliance is located. Remote control handset should be kept out of reach of children.

In the presence of children, we strongly recommend that you install in front of the fireplace: a fire screen or, to protect young toddlers, a “hearth gate”.

Children and adults should be alerted to the hazards of high surface temperature and should stay away to avoid burns or clothing ignition.

### 3.4.3 Flammable materials and liquids

Do not store or use gasoline or other flammable vapors and liquids in the vicinity of this appliance.

Do not use this appliance if any part has been under water. Immediately call a qualified service technician to inspect the unit and to replace any part of the control system and any gas control that has been under water.

### 3.4.4 What do you do if you smell gas?

- Do not try to light any appliance.
- Do not touch any electrical switch; do not use any phone in your building.
- Leave the building immediately.
- Immediately call your gas supplier from a neighbor’s phone. Follow the gas supplier’s instructions.
- If you cannot reach your gas supplier, call the fire department.

## WARNING

Children and adults should be alerted to the hazards of high surface temperature and should stay away to avoid burns or clothing ignition.

## WARNING

This direct vent system appliance must be installed as an OEM installation in manufactured homes (USA only) or an aftermarket permanently located, or a mobile home, **where not prohibited by local codes** and must be installed in accordance with Manufacturer's instructions and the Manufactured Home Construction and Safety Standard, Title 24 CFR, Part 3280, in the United States, or the Standard for Installation in Mobile Homes, CAN/CSA Z240 MH Series, in Canada.

If the information in these instructions is not followed exactly a fire or explosion may result causing property damage, personal injury or death.

Do not store or use gasoline or other flammable vapors and liquids in the vicinity of this appliance.

## WARNING: Glass Handling

The glass must only be removed by a qualified person. Gloves should be worn when removing the glass.

## WARNING: Installation and Service

Installation and service must be performed by an authorized qualified installer, service agency or gas supplier.

Any alteration to the product that causes soot or carbon to form and results in damage is not the responsibility of the manufacturer.

ONLY a qualified person may open the door/remove the glass.

Do not modify or substitute any part of this appliance.

## WARNING: Electrical Grounding

These direct vent appliances must be electrically grounded in accordance with the local codes or, in the absence of local codes, with National Electric code, ANSI/NFPA 70, or the Canadian Electric Code, CSA C22.1

## WARNING: Gas Appliance

This appliance is only for use with the type of gas indicated on the rating plate. These appliances are not convertible for use with other gases unless a certified kit is used and the conversion is performed by an authorized qualified technician.

Applicable standards are ANSI Z21.50/CSA 2.22 (Vented Gas Fireplaces) and CAN/CGA 2.17-M91 (Gas-fired Appliances for Use at High Altitudes.) If your installation is at an elevation greater than 2000' in the US or 4500' in Canada, consult with the local authority having jurisdiction for gas product installations to determine their specific requirements for high altitude installations.

## INSTALLATION MANUAL

This gas fireplace and vent assembly **MUST** be vented directly to the outside and **MUST NEVER** be attached to a chimney serving a separate solid fuel burning appliance. Each gas appliance **MUST BE** a separate vent system. Common vent systems are prohibited.

**TURN OFF** the gas before servicing the appliance. It is recommended that a qualified service technician perform an appliance check-up/service once a year.

Any safety screen or guard removed for servicing **MUST BE REPLACED** before operating this appliance.

This unit **MUST** be used with a vent system as described in this installation manual. **NO OTHER VENT SYSTEM OR COMPONENTS MAY BE USED.**

**THIS UNIT IS NOT FOR USE WITH SOLID FUEL**, and must only be used with gas supply conditions as indicated on the rating label.

**INSPECT** the external vent cap on a regular basis to make sure that no debris, plants, trees, or shrubs are interfering with the air flow.

**DO NOT USE** this appliance if any part has been under water. Immediately call a qualified service technician to inspect the unit and to replace any part of the control system and any gas control that has been under water.

This appliance is for indoor use only.

**DO NOT** use this appliance as a temporary source of heat during construction.

**NEVER OBSTRUCT** the flow of ventilation air. Keep the front of the appliance **CLEAR** of all obstacles and materials for servicing and proper operation.

This appliance is a vented gas fireplace. It must not be used for any other purposes such as drying clothes, etc.

The glass panels **MUST** be in place and sealed before the unit can be placed into safe operation.

If the pilot flame is extinguished either intentionally or unintentionally, no attempt should be made to re-light the gas until at least 3 minutes have elapsed.

**DO NOT OPERATE** this appliance with the glass panels removed, cracked or broken. Replacement of the glass panels should be performed by a licensed or qualified service person. **DO NOT** strike or slam the glass panels.

Dimensions will appear as **INCHES**"/metric throughout this manual. For convenience, the inches are rounded to the nearest 1/16" when converted. If greater accuracy is required, use the metric dimensions.

The glass panels **SHALL ONLY** be replaced by units supplied by the manufacturer. **NO SUBSTITUTE** panels shall be used.

**DO NOT USE** abrasive cleaners on the panels. **DO NOT ATTEMPT** to clean the glass panels when they are hot.

## 4 THE CONTROLS

The control system for the Element4 fireplaces consist of three major components:

- the receiver (**Figure 4.1**)
- the remote (**Figure 4.2**)
- the gas valve (**Figure 4.3**)

The remote is the remote control by which you operate the fireplace. The receiver and the gas control are at one end of a line set which will extend approximately 50"/1270 mm from the center of the fireplace. The other end of the line set is connected to the firebox just left of center.

As shipped, the line set is wrapped together and fixed either under or beside the fireplace. When installing the fire carefully cut the black tie wraps which hold the line set to the bottom of the fireplace then carefully unwrap the line set. Lay the line set out towards the location of an access point.

Do not kink the lineset and do not bend to a radius of less than 2"/50 mm.

**Pro tip:** Always check the line set for loose connection plugs or broken cables, while it has not been built in.

A wall access door (not supplied) should be placed with your fireplace. When locating a wall access you must consider three types of access:

1. Line set access. The line set is to be unwrapped which allows the controls to be then placed within approximately 50"/1270 mm from the center of the fireplace, as the cable runs (**Figure 4.4**).
2. Physical access. The gas valve/receiver must be readily accessible for maintenance, etc.
3. Wireless access. The signals from the remote must get to the receiver, inside the access door. Do not put your line set in a closed off box, the signals from the receiver will not connect with the hand set remote possibly disrupting the connection.
4. Minimum size should be 10" (254mm) x 13" (300mm).
5. If the access door is the only fresh air inlet it should have a minimum air inlet area of 15 sq.in (100mm<sup>2</sup>)

The wall access may be replaced by a comparable design which offers the same access to the line set at the

### 4.1 Electronic ignition

The unit is operated using a remote control (**Figure 4.2**) or the Element4 Puck, connected to a receiver (**Figure 4.1**).

The receiver is powered by 4 pen lite (type AA) batteries or a 6V adapter; 2 penlight batteries (type AAA) are used for the remote control. The life of the batteries is about a year with normal use.



Figure 4.1 - Receiver



Figure 4.2 - Remote Control

#### 4.1.1 Pairing the remote

Press the reset button on the receiver until you hear two beeps. After the second longer signal, let go of the reset button (**Figure 4.1**).

Within 20 seconds, press the down arrow on the remote control until see a count of 1 through 9 on the display. Two beeps will confirm communication with the receiver.

If you hear one long beep, this indicates the pairing sequence has failed or the wiring is incorrect. Re-pair the remote. See **APPENDIX B** for troubleshooting a long beep.



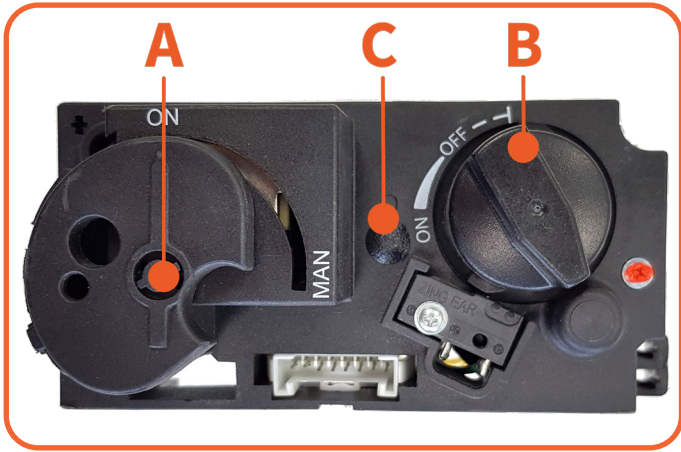

Figure 4.3 - Gas Block

#### 4.1.2 Igniting the pilot light

Check that the control knob (A) is in the ON position (**Figure 4.3**). Press the button on/off button of your remote control and continue to hold down (3 to 5 sec.) until you hear two short beeps.

The ignition sign will appear at the top of the screen (**Figure 4.5**) Now release the button. The ignition procedure is started.

**Note!** If the pilot light doesn't remain lit after 3 attempts you must turn off the gas tap and warn your installer.

#### 4.1.3 Igniting the main burner

After starting the pilot, knob B will automatically rotate counter clockwise and the main burner will start burning (**Figure 4.3**).

**Note!** For normal operation the knob on the gas valve cannot be in the MAN position; it must be fully in the ON position.

**Note!** The pilot light must ignite the main burner, evenly and without a thud. If it does thud, close the gas tap and warn your installer.

If the 2nd thermocouple is not properly heated within 29 seconds the fire will shut itself off as a safety precaution.

So long as the 2nd thermocouple is still hot enough to produce electricity to the receiver, thus preventing the fireplace from starting, the remote will flash "OFF" to signal this safety lock out.

Allow time for the 2nd thermocouple to cool down before attempting a start. The system is ready to start when the flashing "OFF" becomes solid on the remote and pressing the ON/OFF button produces a response from the valve. Always wait 5 minutes after turning the pilot light off before you start the pilot flame again.

#### 4.1.4 Adjusting the burner pressure

In the case that a fireplace has the incorrect burner pressure, one may adjust this by removing the little black cap (C in **Figure 4.3**) and turn the small screw underneath.

Always consult the installer / manufacturer of the fireplace, before making adjustments. Not doing so may result in loss of warranty.

#### 4.1.5 Switching off the fireplace

You switch off the fireplace by pressing the on/off button, this also turns off the pilot light!

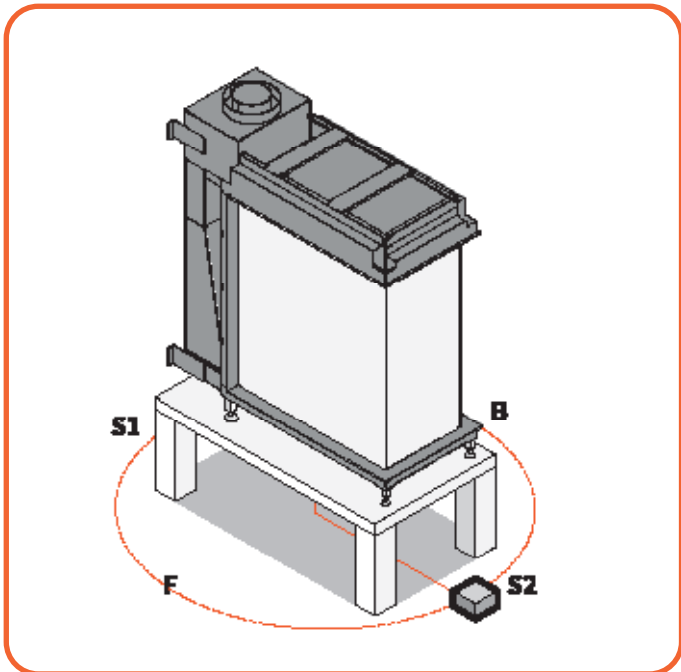

Figure 4.4 - Lineset access

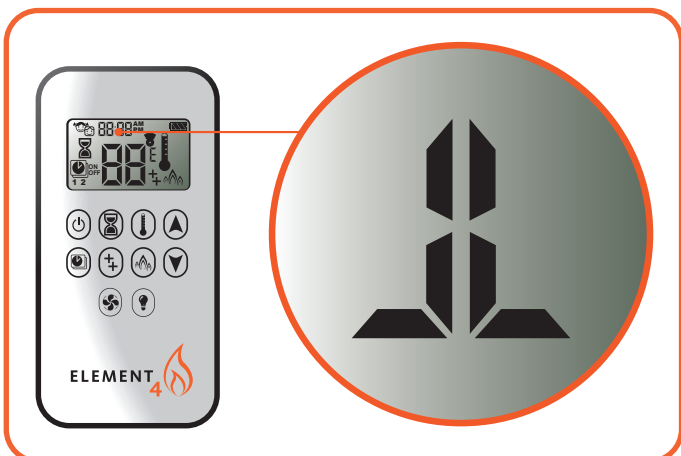

Figure 4.5 - Remote and ignition sign

## 5 GAS INSTALLATION

The device is developed, tested and approved to conform the applicable standards for the usage, the performance and safety of the product. The installation of your device must apply to the current building prescriptions.

We advise to make use of a qualified gas installer for the installation of your device. The installer can provide you with all information regarding the safety regulations of the installation.

This appliance is only for use with the type of gas indicated on the rating plate. These appliances are not convertible for use with other gases unless a certified kit is used and the conversion is performed by an authorized qualified technician.

### 5.1 Attention points gas fireplace

This device can be placed in a new or existing situation. The device can be installed in a fully enclosed or mechanically ventilated room without extra ventilation.

Before installation of these appliances, the area into which the fire is to be fitted must be cleared of all debris (including dust), in particular combustible material.

### 5.2 Attention points gas connection

The gas connection should apply to the local norms in force. Applicable standards are ANSI Z21.50/CSA 2.22 (Vented Gas Fireplaces) and CAN/CGA 2.17-M91 (Gas-fired Appliances for Use at High Altitudes.)

If your installation is at an elevation greater than 2000 feet (600 meter) in the US or 4500 feet (1370 meter) in Canada, consult with the local authority having jurisdiction for gas product installations to determine their specific requirements for high altitude installations. Calculate the diameter of the gas flue, such that no pressure loss is occurring in the pipes. Place a shut-off valve in the near vicinity of the device. Position the gas connection, such that it is always accessible for service purposes.

Before construction of the enclosure, carefully cut the black tie wraps which hold the line set to the bottom of the fireplace. Then carefully unwrap the line set. Lay the line set out towards the location of the access door. Do not kink the lineset and do not bend to a radius of less than 2" / 50 mm. Make sure that the line set is always accessible for service purposes.

### 5.3 Checking the gas lines

To be able to check on the gas lines, it is necessary to have the right equipment. If necessary take out the glass of the device and use the measuring point (see **Figure 15.4**), to check the supply pressure on the gas pipes.

**A** = Supply pressure

**B** = Burner pressure

Make sure the cables of the ignition are hanging loosely under the device, to ensure a good ignition. Remove any tie wraps or other cable binders.

Check the pilot and second thermocouple for obstructions and check the air tightness of the system.

Ensure that the lineset (which includes the gas valve, electrical wiring and gas lines) does not impede the full operation of the relief doors.

Ensure the safety of these critical components throughout the installation process. Remove and dispose of all wraps and ties.

### 5.4 Installing the gas line

In accordance with the latest edition of the National Fuel Gas Code, NFPA 54 (USA) or CAN/CSA-B149.1 (Canada,) correctly size and route the gas supply line from the supply regulator to the area where the appliance is to be installed.

Never use galvanized or plastic pipe unless it is rated for use with gas. Gas supply pipes must be designed, routed, constructed and made of materials that are in strict accordance with local codes and regulations. A qualified plumber or gas fitter should be hired to correctly size and route the gas supply line to the appliance in accordance with all applicable codes and regulations.

Installing a gas supply line from the fuel supply to the appliance involves numerous considerations of materials, protection, sizing, locations, controls, pressure, sediment trap, and other criteria. The sizing and/or installing of gas piping should only be performed by a qualified plumber or gasfitter.

The gas control inlet accepts a 3/8" (9,525 mm) NPT fitting. The gas supply piping should have a separate gas shutoff valve and a capped, 1/8" (0,375mm) pipe tapping upstream of the valve for the purpose of reading pressure. A service shutoff valve must be placed within six feet of the fireplace gas control valve.

The gas supply pressure at the gas control valve must not exceed the Maximum Supply Pressure as shown in the Specifications and Dimensions section of this manual.

The gas supply line must be properly connected and bled by a certified gasfitter or plumber.

Do not modify or substitute any part of this appliance.

The appliance and its main gas valve must be disconnected from the gas supply piping system during any pressure testing of that system at test pressures in excess of 1/2 psi (3.5 kPa). The appliance must be isolated from the gas supply piping system by closing its equipment shutoff valve during any pressure testing of the gas supply piping system at test pressures equal to or less than 1/2 psi (3.5 kPa).

## 6 FIRE SAFE INSTALLATION

To install a gas fireplace as safely as possible, several installation preparations need to be made. This overview can be used to assure the fire safety of a conversion of a fireplace.

### IMPORTANT!

It is important to follow the next installation regulations carefully. When the (local) regulations are insufficient- or not provided with the aspects of fire safety, the instructions according to ANSI Z21.50/CSA 2.22 (Vented Gas Fireplaces) and CAN/CGA 2.17-M91 (Gas-fired Appliances for Use at High Altitudes) are leading.

### 6.1 Fire safety device set-up

Install the device such that there are no flammable materials around the device or enclosure. The device must never be placed against a back wall of combustible materials.

**Please note:** Combustible materials are considered all materials capable of igniting and burning. Any material that is made of, or faced with wood, wood pulp, paper, plastic or any other material that can catch fire and burn is considered combustible.

Flammable materials, such as wood, can combust at a temperature of 185°F (85°C). At high temperatures this can happen within several minutes or at lower temperatures (more than 185°F (85°C)) this may occur over a period of weeks, months or even years.

A gas fireplace can achieve temperatures of over 392°F (200°C) Therefore one should use only non-combustible materials around the fireplace and in the enclosure.

Even materials that have been 'flame-proofed', made 'fire-resistant' or are 'fire-rated' are considered combustible. Standard and Type X drywall are combustible.

A material is non-combustible when it cannot catch fire and burn / smolder. For example, materials made of stone, brick, concrete, tile, steel, plaster or glass are non-combustible.

### 6.2 Place of installation

The base surface upon which the appliance rests must be sturdy, level and built to safely support at least 800 pounds (363 kilograms).

It is recommended that the fireplace be set in its final location before building the enclosure.

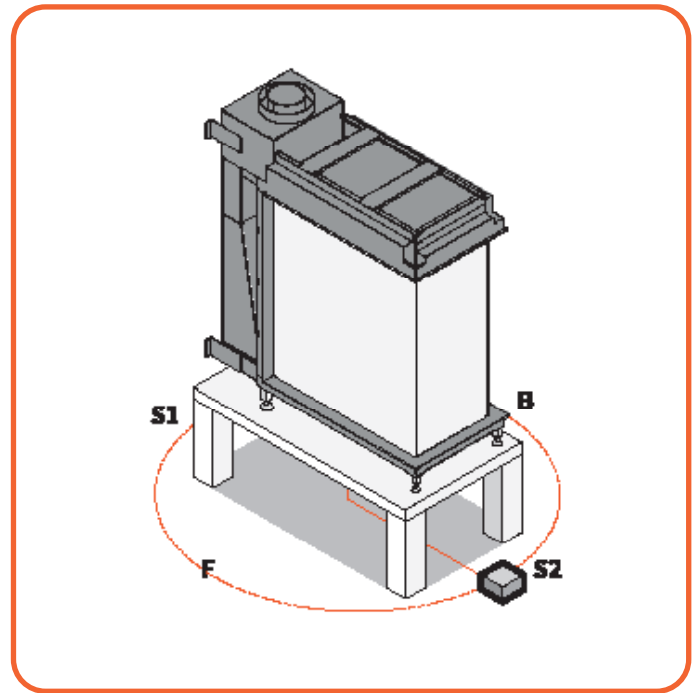

Figure 6.1 - Place of installation

#### 6.2.1 Platform

The base may be the floor or a purpose built raised platform, e.g. wood, metal

**Figure 6.1.** The minimum length of the fireplace legs is 4 1/16 (103.5mm).

When placed on a platform, a minimum opening of 8" (203 mm) x 6" (152 mm) must be cut through the platform top. The maximum opening size is 23" 5/8 (600mm) x 8" (203 mm). The lineset (gas block etc.) can be routed through this opening. The platform should allow air to flow upwards past the fireplace.

#### 6.2.2 Pre-construction test

Before the enclosure is constructed around the fireplace, it is recommended to do a test of the fireplace with all proper venting material installed.

Should anything be out of order, it can be repaired or changed, without having to break out (part of) the enclosure.

For more information on venting and a first firing of the product see **CHAPTER 8** and **CHAPTER 14**.

#### 6.3 Temperature

Fireplaces cause heat and this heat will escape in three ways from its source, namely via conduction (i.e heat release via solid matter), convection (heat release via air) and radiant heat (**Figure 6.2**). In this section the three types of heat are elaborated upon to ensure proper installation precautions are taken into account.

### 6.3.1 Radiant heat

When the fireplace is turned on, radiant heat will escape through the ceramic glass and will heat up the environment. Therefore it is important that a minimal distance between the ceramic glass and any flammable material in front of the fireplace is 36 inches (90cm).

For fireplaces radiant heat is the pleasant warmth commonly associated with fire. The heat felt is mainly radiated from the glass.

#### CAUTION

This appliance is a HEATING appliance and it does become very hot in operation. UNDER ANY CIRCUMSTANCES, DO NOT PLACE any object, furniture, draperies or other item LESS THAN 36" (90 cm) IN FRONT OF THE GLASS OF THE FIREPLACE.

Radiant heat can heat surfaces such as the surround and trims of the fireplace to temperatures that, although approved safe, can be quite uncomfortable to touch - particularly for children and pets. Children and pets should always be supervised when in the room where the appliance is located.

The remote control handset should be kept out of reach of children.

### 6.3.2 Conduction

Conduction is the transfer of heat through solid material. This causes the material to heat up and expel heat.

#### WARNING

The entire exterior of the product, visible or invisible, once installed and built in, will conduct heat. Therefore no parts of the fireplace should be in direct contact with combustible materials.

E.g a screw that is used to secure the brackets of the fireplace could pierce a non-combustible material and touch the flammable material underneath. The heat bridge that is then created can (over time) cause the flammable material to burn. Most of the heat however is conducted through all the parts of the fireplace that are inside the enclosure, which then warms up the air as convection heat.

**PLEASE NOTE:** The materials of the fireplace expand due to conduction heat. Therefore it is not allowed to bear any weight on the fireplace, including any part of the enclosure!

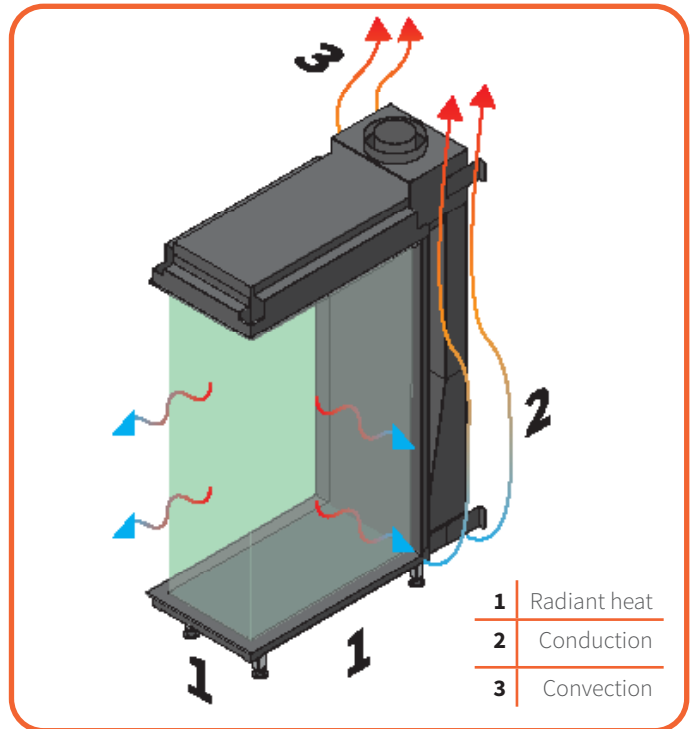

Figure 6.2 - Types of heat

### Enclosure support

Any support of the enclosure, other than the platform under the fireplace (**CHAPTER 8.2**), must be at least 2 inches (5cm) away from any part of the firebox. The frames around the fireplace take into account this distance. Non-combustible materials may be installed to a zero clearance to the outer faces of the appliance outer frame face, given they not cover or prevent the removal of the glass panels or other parts of the fireplace that need to be removed during maintenance.

The entire weight of the walls must be borne by a structure other than the fireplace.

#### WARNING

Children and adults should be alerted to the hazards of high surface temperature and should stay away to avoid burns or clothing ignition.

### 6.3.3 Convection

The majority of the heat produced by Element4 fireplaces is quickly given off to the air around the fireplace. Convection is this transfer of heat through air.

Because most of the fireplace is installed inside of the construction of a enclosure, most of the air surrounding the fireplace and therefore the air being warmed up, is located inside the enclosure. Therefore several precautions need to be taken into account, which will be explained in **CHAPTER 8**.

## 6.4 Assembly regulations

### 6.4.1 Protection of wall and ceiling

There are two kinds of walls/ceilings that can be distinguished, respectively;

#### 1. Combustible surfaces

Walls/ceilings that are made of – or contain flammable building materials, and all walls on which flammable objects (e.g. built-in furniture or wooden panels) are mounted on the side of the wall that is turned away from the fireplace.

#### 2. Non-combustible surfaces

Walls/ceilings made of mineral building materials (concrete, bricks, sandstone etcetera.) of more than 4 inches (10cm) thickness.

### 6.4.2 Floor protection

The temperature of the floor under the device needs be less than 185°F (85°C). A minimal distance of 4 inches (10cm) is to be taken into account under the fireplace.

Make sure there is a good air ventilation in the enclosure (see **CHAPTER 7**). The temperature that leaves through the ventilation grilles must not be higher than 185°F (85°C). Therefore one should always make sure there are enough ventilation grilles in the upper and lower parts of the enclosure.

No material of any kind is allowed between the bottom of the support feet and the bottom of the firebox (except for the lineset).

### 6.4.3 Assembly regulations with non-combustible materials (Figure 6.3 and Figure 6.4)

Load-bearing walls and ceilings must be covered in a protective fire resistant plate.

The minimal distance between the device and non-flammable materials must be at 2 inches (50 mm) to ensure a convection air flow.

For the best result the finished wall(s) must be at least 0,5 inch (12,5mm) thick. This thickness corresponds with the flanges on the frame of the fireplace, which allows the finish of the wall to be properly covered by the trims of the fireplace.

### 6.4.4 Assembly regulations for combustible materials (Figure 6.5 and Figure 6.6)

The minimum distance of the exterior surface (either the back or the non-glass sides) of your fireplace to a combustible wall is 11 inches (280mm), when no protection of said wall is used.

However, it is possible to reduce this clearance by using a shielding wall.

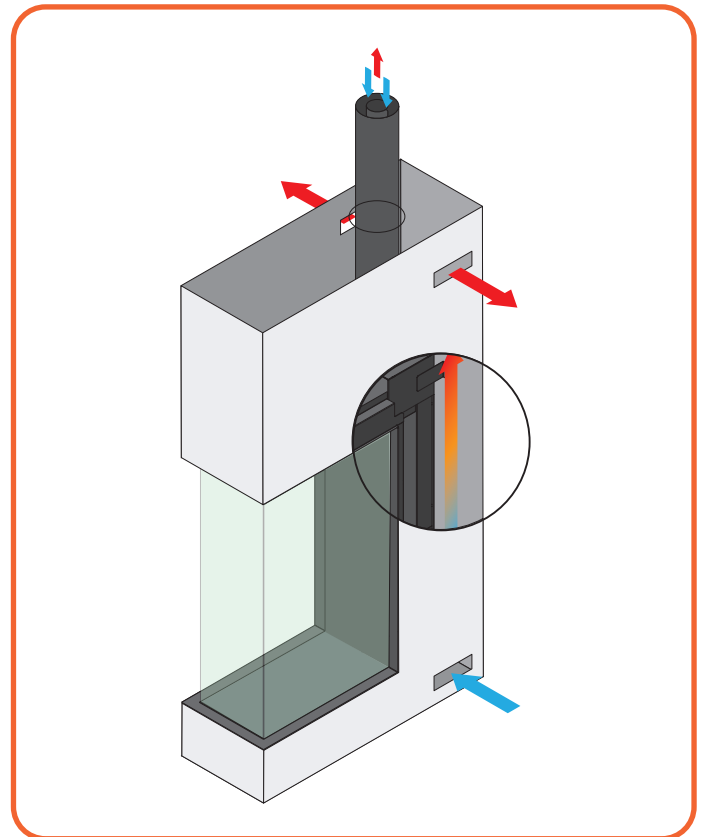

Figure 6.3 - Non combustible material enclosure

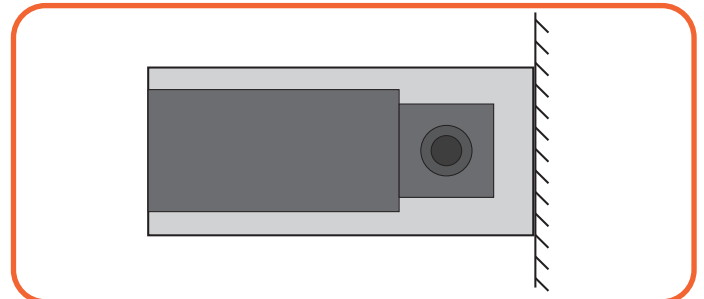

Figure 6.4 - Non combustible material enclosure top view

### Shielding walls

To reduce the clearance between a combustible wall and your fireplace a heat shield of non-combustible material may be used. See **Figure 6.7** for an isometric overview.

- Cover the walls/ceilings with a non-combustible plate at the reduced clearance of 1 inch (2,5cm)
- Keep the fireplace away from the heat shield by a minimum of 2 inches (50mm).
- A wall heat shield must not be placed closer than 1 inch (25mm) from the floor or any intersection walls. Air must be able to continually circulate around all side of the shielding.

### WARNING

Make sure that the heat shield is not attached to the combustible wall by screws or nails. Due to their conductivity these metals can cause problems such as a central heat bridge.

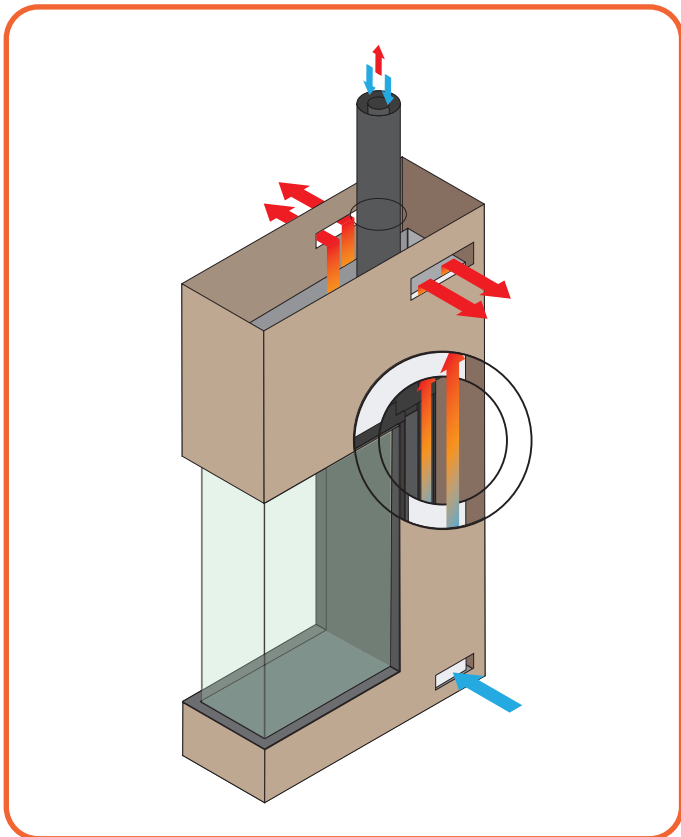

Figure 6.5 - Combustible material enclosure

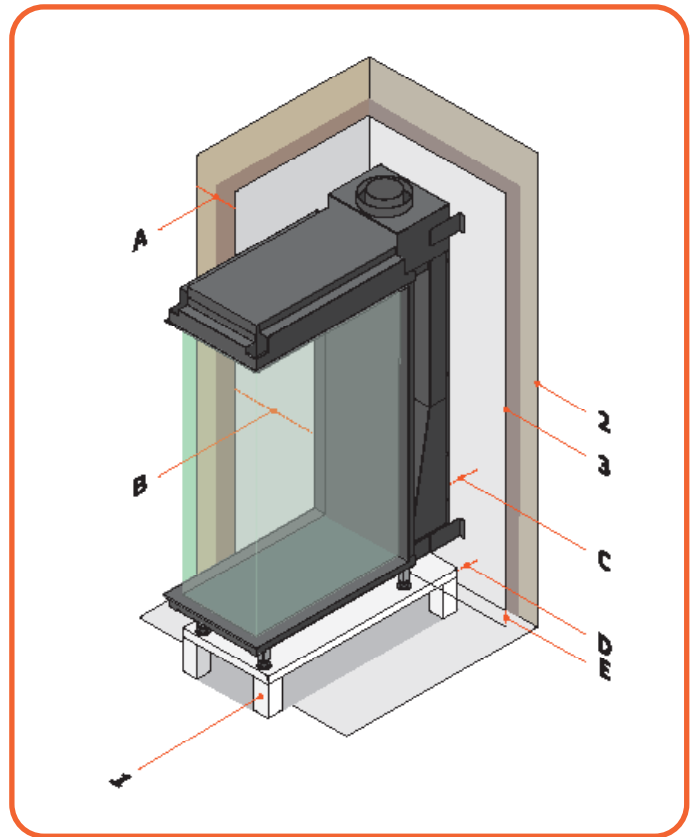

Figure 6.7 - Shielding the enclosure

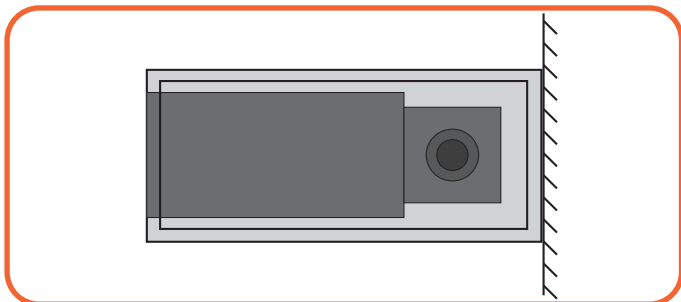

Figure 6.6 - Combustible material enclosure top view

- |          |                                 |
|----------|---------------------------------|
| <b>1</b> | Raised platform                 |
| <b>2</b> | Exterior combustible wall       |
| <b>3</b> | Protective non combustible wall |
| <b>A</b> | 1 inch / 25 mm gap              |
| <b>B</b> | 2 inches / 50 mm gap            |
| <b>C</b> | 2 inches / 50 mm gap            |
| <b>D</b> | 1 inch / 25 mm gap              |
| <b>E</b> | 1 inch / 25 mm gap              |

Table 6.2

#### 6.4.5 Approved non-combustible materials

The following materials are approved to use for the construction of the enclosure

Product		Thickness	
Brand	Type	Imperial	Metric
Skamol	SkamoEnclosure SkamoStove	1.5 Inch	37.5 mm
Promat	PROMAFOUR system	0.5 inch	12.5mm
James Hardie building products	Hardiebacker 500 1/2" cement board	0.5 inch	12.5mm
	Hardiebacker 1/4" cement board	0.25 inch	6.25 mm

Table 6.1

#### 6.4.6 Fresh Air inlet Area by Model

The amount of surface necessary for the fresh air coming into the chase for the fires as per table below.

Model	Square Inches	Square Centimeters
Sky LRD	15	100
Sky MRD	15	100
Sky SRD	15	100

Table 6.3

## 7 ENCLOSING THE FIREPLACE

### 7.1 Hot air outlets and ventilation grilles

As stated in **CHAPTER 6.3.3** the air in the enclosure will be heated by the fireplace. Hot air expands and will rise up. If the proper ventilation of the enclosure is not taken into account, this may cause cracking of the enclosure exterior or heat problems in the long run.

To properly ventilate the enclosure the correct precautions have to be made.

The most common option is the use of combustion air outlets placed in the top and bottom of the enclosure. These outlets are slots through which air can flow freely.

The ventilation grilles are to be placed at a minimal distance of 1 foot (30cm) from the ceiling and 1 foot (30cm) from any built-in furniture from the side, any flammable material or load-bearing concrete parts.

**Pro tip:** To avoid heat accumulation in the enclosure a non-flammable false ceiling (see **Figure 7.2**) is to be placed directly above the outlets to guide the hot air out. The ventilation grilles need to be easy to clean at all times.

#### Please note

If a hot air outlet is placed closer to the ceiling than the aforementioned distances, the sudden change in temperature of the surrounding air, when exiting the enclosure, may cause the solid particles in the convection air to settle on the ceiling, causing a black or brown soot stain. It however, will not be of influence on the air flow in the enclosure.

Another option is to create e.g. a recess in the wall near the ceiling, so air can flow out of enclosure. Both options are shown in **Figure 7.1**.

An installer is free to choose the design of the ventilation openings as long as the prescribed amount of air is taken into account. Ventilation grilles may deviate from standard model.

#### 7.1.1 Electrical pipes

The conversion has to be free of the usual electric installation pipes, if these are not protected against temperatures over 86°F (30°C) by the necessary precautions. Special pipelines with an heightened heat resistance are permitted.

#### 7.1.2 Cold climate installation

For cold climate installations, it is especially important to insulate outside the chase cavity, between studs and under the floor on which appliance rests, if floor is above ground level. Gas line holes and other openings should be filled with approved firestop.

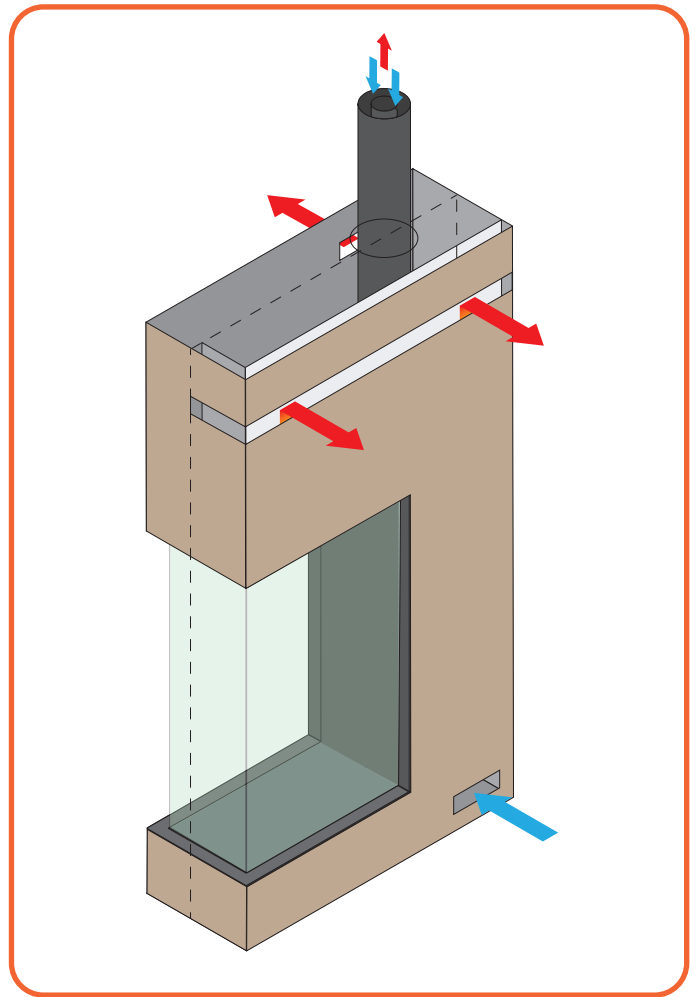

Figure 7.1 - Convection opening in the enclosure top

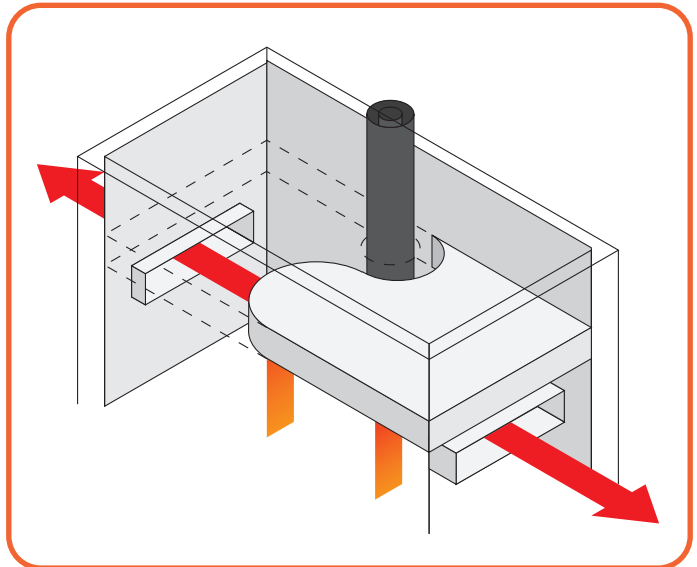

Figure 7.2 - False chimney in the enclosure

If the fireplace is being installed on a cement slab in cold climates, a sheet of plywood or a raised platform can be placed underneath to prevent cold transferring to the fireplace and into the room. It also helps to tape the venting for maximum air tightness and to caulk the firestops.

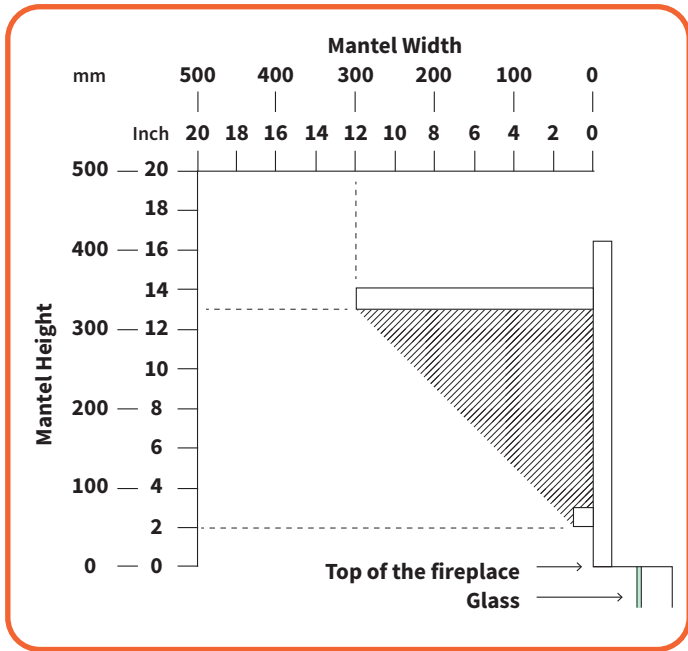

Figure 7.3 - Mantel dimensions above the fireplace

## 7.2 Clearances (overview)

In summary; the minimum clearances (air spaces) to combustible materials must be maintained. It is of the greatest importance that the fireplace and vent system be installed only in accordance with these instructions.

Clearance to combustibles	Inches	Millimeters
Back	11	280
Sides (Non glass)	11	280
Top	26	660
Floor	4	100

Table 7.1

Clearance to non-combustibles	Inches	Millimeters
Back	2	50
Sides (Non glass)	2	50
Top	26	660
Floor	4	100

Table 7.2

### Please note:

The **Floor** dimension above is measured from the bottom of the firebox. When the adjustable feet are in their lowest position the required 4" clearance is achieved.

## 7.3 Decorating the enclosure

Although the main task of the enclosure is to house the fireplace, it is not solely used for that purpose. When properly executed there are many possibilities with the decoration of the enclosure, two of which are elaborated upon below.

### 7.3.1 Mantels

Often a mantel is installed above the fireplace, for the classic look and to put decorations on.

Figure 7.3 shows a range of allowable depths and heights for a combustible mantel installation.

As shown, the minimum allowable mantel height above the fireplace opening is 2" (50 mm) with a 1" (25 mm) deep mantel. The maximum mantel depth is 12" (300 mm) at a minimum height above the fireplace opening of 13" (330 mm). All of the mantel height/depth combinations fall in between these extremes in accordance with the chart on this page.

Mantels made of non-combustible material are allowed inside these dimensions but they will be subjected to elevated temperatures and may become too hot to touch.

### 7.3.2 Televisions

An Element4 fireplace is a perfect furniture piece to connect with a TV, once the necessary precautions are taken. A TV may be placed above the fireplace as long as the hot air cannot influence its functioning.

A wall recess is a good option to accomplish the installation. For more info contact your local dealer.



7.4 Fire specific dimensions

Every fireplace has specific distances for which the right precautions need to be taken into account (Figure 7.4 and Table 7.3).

7.4.1 Minimal chimney dimensions

Product		A	H1	H2	W	D
Sky LRD	"	12	85 13/16	72	17 1/4	43 13/16
	mm	300	2182	1830	438	1113
Sky MRD	"	12	66 1/2	72	17 1/4	43 13/16
	mm	300	1690	1830	438	1113
Sky SRD	"	12	50 3/4	72	17 1/4	43 13/16
	mm	300	1290	1830	438	1113

Table 7.3

- A** Room ceiling to top of Warm Air Outlet
- H1** Minimal internal enclosure height
- H2** Room ceiling to appliance bottom
- W** Minimal enclosure width necessary
- D** Minimal enclosure depth necessary

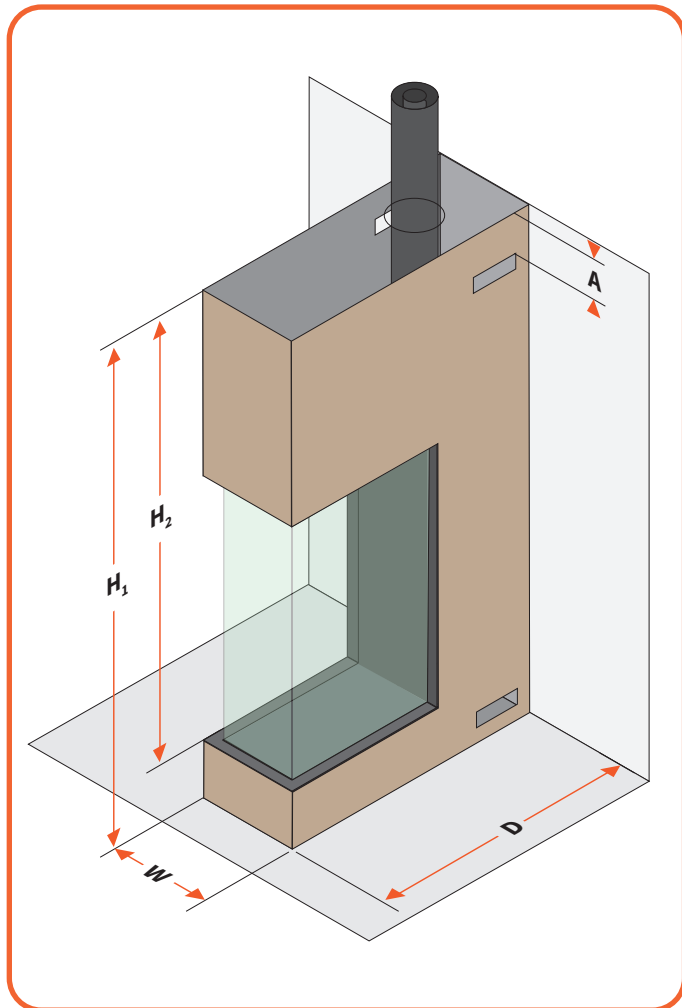

Figure 7.4 - Specific distances

7.4.2 Warm Air Outlet Area by Model

The amount of surface necessary for the hot convections air to flow away properly for the fires as per table below.

Model	Square Inches	Square Centimeters
Sky LRD	50	322
Sky MRD	50	322
Sky SRD	50	322

Table 7.4

7.4.3 Fresh Air inlet Area by Model

The amount of surface necessary for the fresh air coming into the chase for the fires as per table below.

Model	Square Inches	Square Centimeters
Sky LRD	15	100
Sky MRD	15	100
Sky SRD	15	100

Table 7.5

7.5 Roomdivider installation guidelines

The fireplace is supplied with an installation bracket. This bracket should be used instead of the side glass to keep the frame fixed while installing.

In order to prevent the side glass pane from being under too much tension it is strongly recommended to connect the topside of the fireplace to the ceiling or any other support structure. The fireplace has two rod ends installed at the topside and is supplied with 2 turnbuckles that can be used to connect the fireplace to a support structure.

7.5.1 Line set access (see Figure 7.6)

	Front (F)		Side 1 (S1)		Side 2 (S2)		Back (B)	
	(")	(mm)	(")	(mm)	(")	(mm)	(")	(mm)
<b>Sky LRD</b>	54	1372	32	813	32	813	54	1372
<b>Sky MRD</b>	54	1372	32	813	32	813	54	1372
<b>Sky SRD</b>	54	1372	32	813	32	813	54	1372

Table 7.6

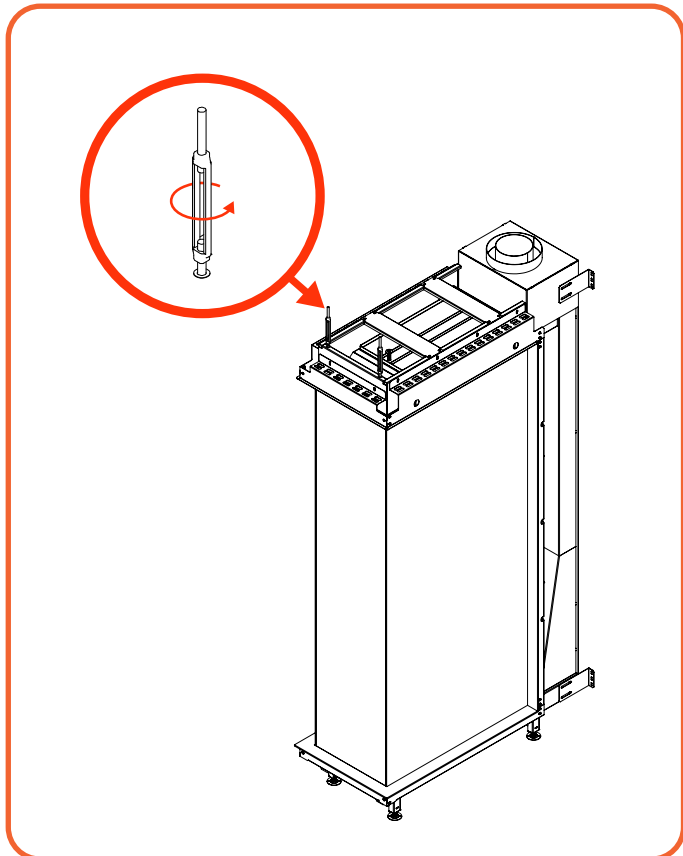

Figure 7.6 - Specific distances

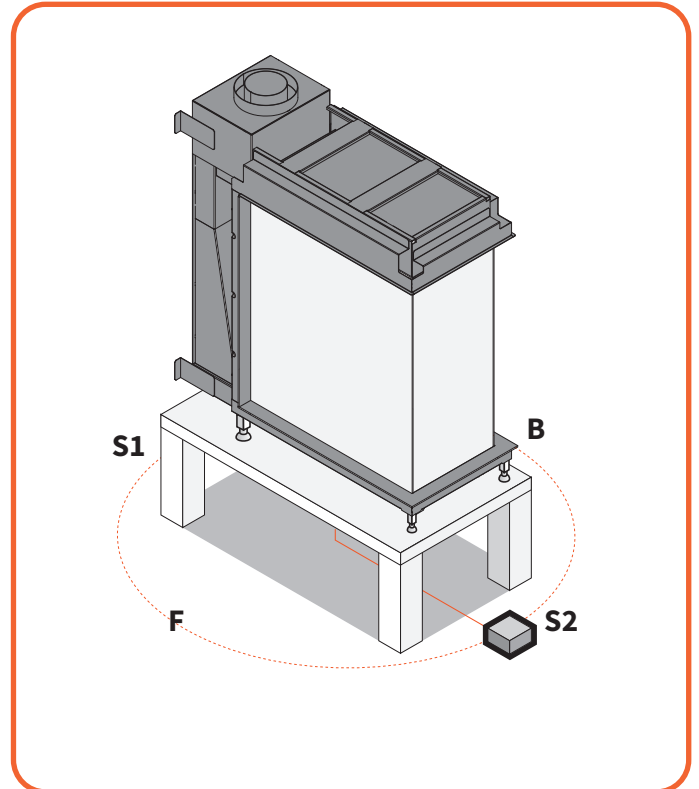

Figure 7.5 - Line set access

**8 VENTING REQUIREMENTS**

To guarantee the fire safety regarding your vent configuration, a vent chase is necessary. For this case non-combustible materials should be used. Make sure to always ventilate a shaft and never to insulate it, to make sure the hot air is able to get away.

Every transit or terminal should be made such, that the warmth-insulation and non-combustability is guaranteed, according to the building regulation.

**8.1 General safety rules regarding venting material**

This unit must be used with a vent system as described in this manual. The usage of other concentric material is only permitted when it has the same technical specifications as the systems mentioned below.

The following table lists brands of vent material that have been approved for the North American market. The device must be installed with the (stainless steel) flue material as specified.

**Vent Manufacturers**

M&G DuraVent, Inc	DirectVent Pro
ICC - Industrial Chimney Company	EXCELDirect
BDM - Bernard Dalsin Manufacturing	Pro-Form
Selkirk Corporation	Direct-Temp
Hart & Cooley Inc.	AmeriVent Direct Vent
Olympia Chimney Supply, Inc.	Ventis Direct Vent

**Table 8.1**

It is only by the use of these brands that a good and safe performance can be promised (given a proper installation.)

The gas fireplace MUST

- be vented directly to outside.
- NEVER be attached to a chimney serving a separate solid fuel burning appliance.
- be a separate vent system. No more than one fireplace is allowed on the same venting system.

The vent may be constructed with either a roof terminal or a wall terminal. The use of flexible venting material to an existing chimney is allowed. Please check whether the desired terminal complies with the regulations in your situation. Local norms and regulations may differ from the general rules in this manual.

**8.2 Installation of venting material**

Follow the following (general) instructions for the installation of venting materials;

- This fireplace is shipped with a North American venting adapter (see **Figure 8.1**). It MUST attach to the vent collar of the fireplace.
- Drill a hole of 6,5 inches (160 mm) for the wall or roof transit with a 6" (150 mm) diameter flue connection, and 8,5 inches (210 mm) with a flue with a diameter of 8 inches (200 mm).
- Provide a (fire) safe transit construction in wall, floor or roof sheeting. Whenever venting passes through a wall, an approved heat shield or 'wall thimble' must be installed.
- A minimum clearance of 3" (75 mm) must be maintained between combustible materials and the top of any horizontal vent pipe surface
- A minimum clearance of 1" (25 mm) must be maintained between combustible materials and any other vent pipe surface.
- The horizontal parts of the venting must be pitched up away from the fireplace. For every 12" (305 mm) of horizontal run, the venting must rise 1/4" (6.5 mm) toward the termination.
- The venting must never run downward unless with the use of a power vent.
- Build up the system from the fireplace.
- Assemble vent pipes in the correct direction! The inner vent pipe goes into - and the outer vent pipe goes over the fireplace connection.
- Make sure the vent pipes are sufficiently braced, so the weight of the vent pipes being supported by the fireplace.
- The concentric pipes could come loose due to expansion and cooling down. It is recommended that a chuck parker be used in places that are inaccessible after installation.
- In colder climate environments, the fireplace can be lowered to STANDBY MODE (Pilot Flame only) (\*). This will help maintain a steady draft within the venting over a period of up to five days.

\* ) Does not apply to fireplaces with a power vent

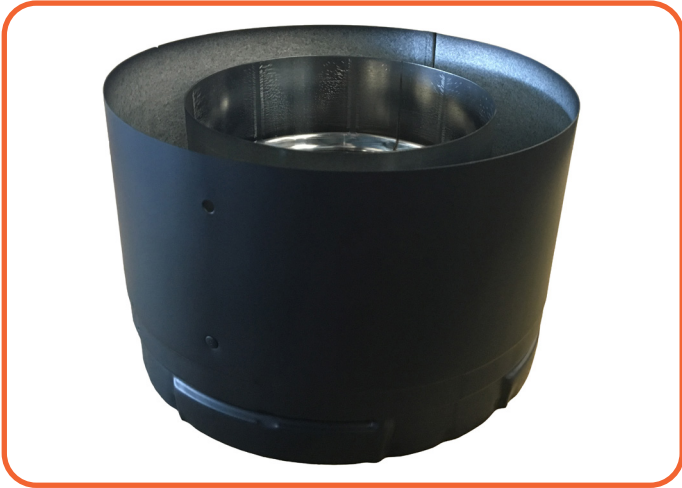

Figure 8.1 - North American vent adapter (5/8")

### 8.2.1 Adapting the length of the chimney

Not all parts can be adjusted! To fit the vent system correctly, you are to use an adjustable fitting. You can use an adjustable concentric / co-axial pipe, wall or roof fitting. To get a sealed vent gas connection, the inner pipe must always be an inch (2 cm) longer than the outer pipe. Always attach adjustable parts with a chuck.

### 8.2.2 Calculate chimney

For proper operation of the fireplace it is important that the flue pipe meets the requirements. To determine this, a calculation chart is prepared which can be found in **CHAPTER 9**.

## 8.3 Determining the vent gas extraction diameter

The fireplace has a vent diameter of 5"/8" (200/130mm.) It is not necessary to start with a vertical length for the Sky Series fireplaces. A bend can be installed directly onto the fireplace. When your vent only graduates vertically, you may taper directly onto the stove, to a diameter of 4"/6" (150/100 mm).

### 8.3.1 Determining maximum vertical length

If you are using a diameter of 5"/8" (200/130mm) then your maximum total length is 72 feet / 22 meters. If you have tapered your vent gas extraction as per the above, to a diameter of 4"/6" (150/100 mm), then the total maximum permitted vertical length of your vent gas extraction is 36 feet / 11 meters.

### 8.3.2 Determining maximum horizontal length

A gas fireplace, in contrast to classic log fires, can have a horizontal flue section. The maximum horizontal section is 17 feet (5m) and is directly dependent on the vertical section.

In order to determine whether your intended vent configuration shall function properly, a venting category is determined, which can be found in **CHAPTER 9**.

Each category refers to a table. Each appendix has two tables:

1. A table for a horizontal terminal.
2. A table for a vertical terminal.

You must use the table applicable to you. You calculate your Total Vertical Section (TVS) as well as your Total Horizontal Section (THS).

### Calculating the Total Vertical Section (TVS)

You calculate the Total Vertical Section by adding up all vertical upward sections in the extraction gradation.

### Calculating the Total Horizontal Section (THS)

You calculate the Total Horizontal Section by adding up all horizontal parts in the extraction gradation.

In the table you will find advice; TVS on the vertical axis and THS on the horizontal axis.

### 8.3.3 Elbows

Be aware of the bends in your vent. They provide extra resistance in the system and must therefore be included in the TVS and THS.

There are 2 bend types:

- 45° and 90° elbows (**Type N**)
  - From vertical to horizontal
  - From horizontal to vertical
- 45° and 90° elbows (**Type Q**)
  - From horizontal to horizontal

The first 3 type N elbows (from vertical to horizontal) do not need to be included in your calculations. The next type N elbows are each calculated as 1 horizontal meter (39 3/8") in the THS.

For a type Q elbow (horizontal to horizontal) the following applies:

- 90° elbow in the horizontal section counts as 2 horizontal meters (78 3/4") in the THS.
- 45° elbow in the horizontal section counts as 1 horizontal meter (39 3/8") in the THS

Extraction sections in a 45° upward pipe:

- 45° upward sections are calculated both vertically and horizontally.

### 8.3.4 Results

Once you have found your total vertical section (TVS) and your total horizontal section (THS) plot the intersection of these two numbers on the appropriate chart, below.

The intersecting block will have one of two entries; V or X:

#### Result Action

V	The installation is allowed
X	The installation is not allowed with this vent configuration. Try adjusting the dimensions.

*Table 8.3*

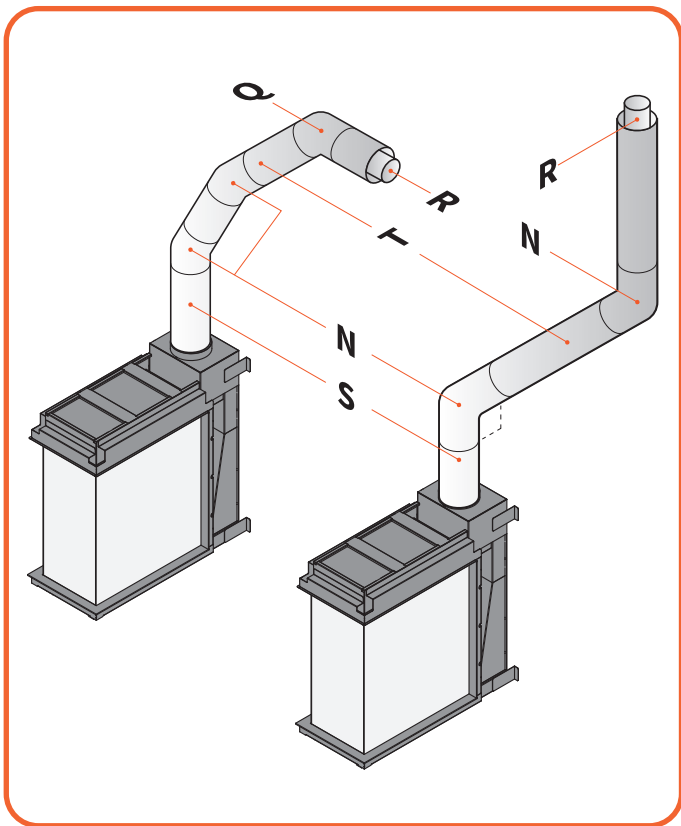

*Figure 8.2 - Vent elbows examples*

<b>R</b>	Horizontal or vertical terminal
<b>N</b>	Elbow 45° & 90° vertical to horizontal and vice versa
<b>Q</b>	Elbow 45° & 90° horizontal to horizontal
<b>T</b>	Vent pipe section horizontal
<b>S</b>	Vent pipe section vertical

*Table 8.2*

## 9 VENT CALCULATION TABLE

The calculation table shows when your installation has the correct vent configuration.

### Result Action

V	The installation is allowed
X	The installation is not allowed with this vent configuration. Try adjusting the dimensions. *

### 9.1 Horizontal termination

#### Imperial

Total vertical Section	36'	V	V	V	V	V	V	V	V	V	V	V
	33'	V	V	V	V	V	V	V	V	V	V	V
	30'	V	V	V	V	V	V	V	V	V	V	V
	27'	V	V	V	V	V	V	V	V	V	V	V
	24'	V	V	V	V	V	V	V	V	V	V	V
	21'	V	V	V	V	V	V	V	V	V	V	V
	18'	V	V	V	V	V	V	V	V	V	V	V
	15'	V	V	V	V	V	V	V	V	V	V	V
	13'6"	V	V	V	V	V	V	V	V	V	V	V
	12'	V	V	V	V	V	V	V	V	V	V	V
	10'6"	V	V	V	V	V	V	V	V	V	V	V
	9'	V	V	V	V	V	V	V	V	V	V	V
	7'6"	V	V	V	V	V	V	V	V	V	V	V
	6'	V	V	V	V	V	V	V	V	V	V	X
	4'6"	V	V	V	V	V	V	V	X	X	X	X
	3'	V	V	V	V	V	X	X	X	X	X	X
20"	V	V	V	X	X	X	X	X	X	X	X	
	20"	3'	4'6"	6'	7'6"	9'	10'6"	12'	13'6"	15'	16'6"	
	Total Horizontal Section											

#### Metric

Total vertical Section	11 m	V	V	V	V	V	V	V	V	V	V	V
	10 m	V	V	V	V	V	V	V	V	V	V	V
	9 m	V	V	V	V	V	V	V	V	V	V	V
	8 m	V	V	V	V	V	V	V	V	V	V	V
	7 m	V	V	V	V	V	V	V	V	V	V	V
	6 m	V	V	V	V	V	V	V	V	V	V	V
	5 m	V	V	V	V	V	V	V	V	V	V	V
	4 m	V	V	V	V	V	V	V	V	V	V	V
	3.5 m	V	V	V	V	V	V	V	V	V	V	V
	3 m	V	V	V	V	V	V	V	V	V	V	V
	2.5 m	V	V	V	V	V	V	V	V	V	V	V
	2 m	V	V	V	V	V	V	V	V	V	V	V
	1.5 m	V	V	V	V	V	V	V	V	V	X	X
	1 m	V	V	V	V	V	V	V	X	X	X	X
	0.5 m	V	V	V	V	X	X	X	X	X	X	X
		0 m	0.5 m	1 m	1.5 m	2 m	2.5 m	3 m	3.5 m	4 m	4.5 m	5 m
	Total Horizontal Section											

\* Please contact your dealer regarding if a power vent will work in your situation

# INSTALLATION MANUAL

## 9.2 Vertical termination vent diameter

For a vertical termination the minimal starting length is **20 inches (or 0.5 meter)** before the first elbow and the minimal vertical section is **3 feet (or 1 meter)**.

### Imperial

Total vertical Section	72'	V	V	X	X	X	X	X	X	X	X	X
	69'	V	V	V	V	X	X	X	X	X	X	X
	66'	V	V	V	V	V	V	X	X	X	X	X
	63'	V	V	V	V	V	V	V	V	X	X	X
	60'	V	V	V	V	V	V	V	V	V	V	X
	57'	V	V	V	V	V	V	V	V	V	V	V
	54'	V	V	V	V	V	V	V	V	V	V	V
	51'	V	V	V	V	V	V	V	V	V	V	V
	48'	V	V	V	V	V	V	V	V	V	V	V
	45'	V	V	V	V	V	V	V	V	V	V	V
	42'	V	V	V	V	V	V	V	V	V	V	V
	39'	V	V	V	V	V	V	V	V	V	V	V
	36'	V	V	V	V	V	V	V	V	V	V	V
	33'	V	V	V	V	V	V	V	V	V	V	V
	30'	V	V	V	V	V	V	V	V	V	V	V
	27'	V	V	V	V	V	V	V	V	V	V	V
	24'	V	V	V	V	V	V	V	V	V	V	V
	21'	V	V	V	V	V	V	V	V	V	V	V
	18'	V	V	V	V	V	V	V	V	V	V	V
	15'	V	V	V	V	V	V	V	V	V	V	V
	13'6"	V	V	V	V	V	V	V	V	V	V	V
	12'	V	V	V	V	V	V	V	V	V	V	V
	10'6"	V	V	V	V	V	V	V	V	V	V	V
	9'	V	V	V	V	V	V	V	V	V	V	V
7'6"	V	V	V	V	V	V	V	V	V	V	V	
6'	V	V	V	V	V	V	V	V	V	V	X	
4'6"	V	V	V	V	V	V	V	X	X	X	X	
3'	V	V	V	V	V	X	X	X	X	X	X	
		0	20"	3'	4'6"	6'	7'6"	9'	10'6"	12'	13'6"	15'
		Total Horizontal Section										

# INSTALLATION MANUAL

## Metric

Total vertical Section	22 m	V	X	X	X	X	X	X	X	X	X	
	21 m	V	V	V	X	X	X	X	X	X	X	
	20 m	V	V	V	V	V	X	X	X	X	X	
	19 m	V	V	V	V	V	V	X	X	X	X	
	18 m	V	V	V	V	V	V	V	V	V	X	
	17 m	V	V	V	V	V	V	V	V	V	V	
	16 m	V	V	V	V	V	V	V	V	V	V	
	15 m	V	V	V	V	V	V	V	V	V	V	
	14 m	V	V	V	V	V	V	V	V	V	V	
	13 m	V	V	V	V	V	V	V	V	V	V	
	12 m	V	V	V	V	V	V	V	V	V	V	
	11 m	V	V	V	V	V	V	V	V	V	V	
	10 m	V	V	V	V	V	V	V	V	V	V	
	9 m	V	V	V	V	V	V	V	V	V	V	
	8 m	V	V	V	V	V	V	V	V	V	V	
	7 m	V	V	V	V	V	V	V	V	V	V	
	6 m	V	V	V	V	V	V	V	V	V	V	
	5 m	V	V	V	V	V	V	V	V	V	V	
	4 m	V	V	V	V	V	V	V	V	V	V	
	3.5 m	V	V	V	V	V	V	V	V	V	V	
	3 m	V	V	V	V	V	V	V	V	V	V	
	2.5 m	V	V	V	V	V	V	V	V	V	X	
2 m	V	V	V	V	V	V	V	V	X	X		
1.5 m	V	V	V	V	V	V	V	X	X	X		
1 m	V	V	V	V	V	V	V	X	X	X		
		0 m	0.5 m	1 m	1.5 m	2 m	2.5 m	3 m	3.5 m	4 m	4.5 m	5 m
		Total Horizontal Section										



10 VENT TERMINATIONS

10.1 Vertical Terminations - clearances and requirements (Figure 10.1 & Figure 10.2)

Important Note for Roof Terminations

These instructions should be used as a guideline and do not supersede local codes in any way. Install venting according to local codes, these instructions, the current National Fuel Gas Code (ANSI Z223.1 in the USA) or the current standard of CAN/CSA-B149.1 in Canada.

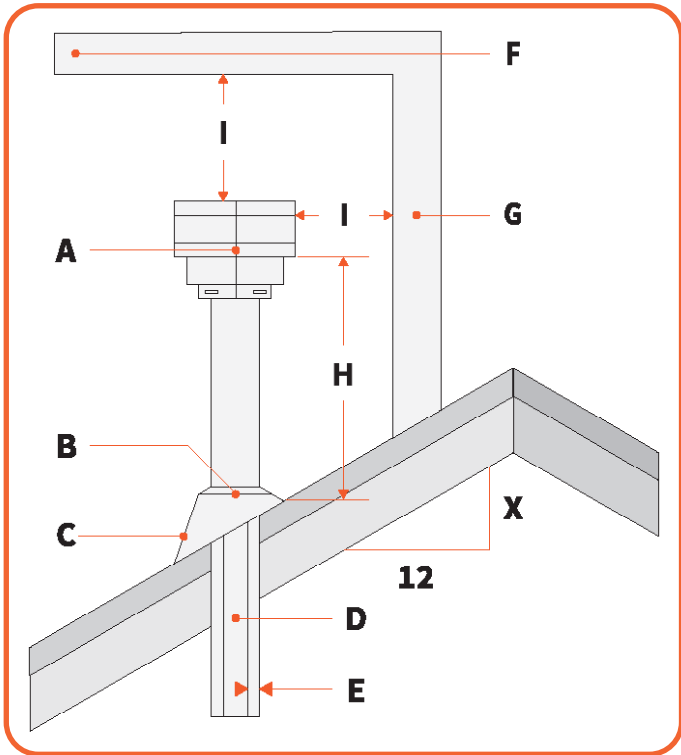

Figure 10.1 - Vertical Vent Termination Clearances

#	Description
A	Vent termination
B	Storm Collar
C	Flashing
D	Concentric vent pipe
E	Minimum clearance to combustibles 1 inch (2.5 cm)
F	Horizontal overhang
G	Vertical wall
H	Minimum height from roof to lowest discharge opening of vent
I	Minimum distance between terminal and vertical wall / horizontal overhang = 2 feet (60 cm)
J	Minimum distance between two roof terminations 12 inches (30 cm)

10.1.1 Termination height for vents above flat or sloped roofs (Ref. NFPA 54 / ANSI Z 223.1)

The vent / air intake termination clearances above the high side of an angled roof (H in the table above) is as shown in the following chart:

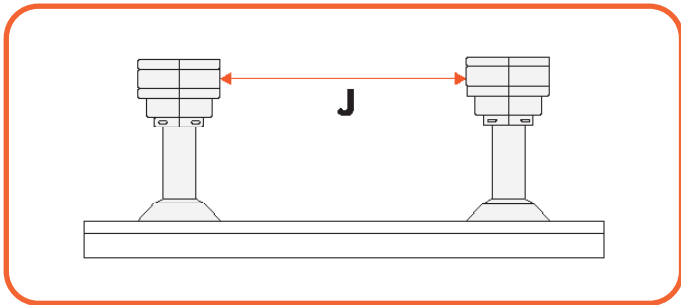

Figure 10.2 - Multiple termination clearance

Roof Pitch (X)	Imperial (Feet)	Metric (meters)
Flat to 6/12	1.00	0.30
6/12 to 7/12	1.25	0.38
7/12 to 8/12	1.50	0.46
8/12 to 9/12	2.00	0.61
9/12 to 10/12	2.50	0.76
10/12 to 11/12	3.25	0.99
11/12 to 12/12	4.00	1.22
12/12 to 14/12	5.00	1.52
14/12 to 16/12	6.00	1.83
16/12 to 18/12	7.00	2.13
18/12 to 20/12	7.50	2.29
20/12 to 21/12	8.00	2.44

Table 10.1

**10.2 Horizontal terminations - clearances and requirements**

Figure 10.3, Figure 10.4 and the table below show a range of distances, that need to be taken into account for the installation of fireplaces with a horizontal vent termination.

	<b>US INSTALLATION**</b> <b>Imperial (Metric)</b>	<b>CANADA INSTALLATION*</b> <b>Imperial (Metric)</b>
<b>A</b>	Clearance above grade, veranda, porch, deck or balcony	• 12 inches* (30 cm)
<b>B</b>	Clearance to window or door that may be opened	• 6 inches (15 cm) for appliances <10k BTUh (3 kWh) • 9 inches / 22.5 kWh for appliances 10k < X <50k BTUh (3 < X <15 kWh) • 12 inches (30 cm) for appliances > 50k BTUh (15 kWh) **
<b>C</b>	Clearance to permanently closed window (Recommended to prevent window condensation).	• 12 inches (30 cm)
<b>D</b>	Vertical clearance to ventilated soffit located above the termination	• 18 inches (45 cm) horizontally from the center line of the termination
<b>E</b>	Clearance to unventilated soffit	• 12 inches (30 cm)
<b>F</b>	Min. clearance to outside corner	• 5 inches (12.5 cm)
<b>G</b>	Min. clearance to inside corner	• 6 inches (15 cm) – SV 4.5 HT-2
<b>H</b>	Clearance to each inside of center line extended above meter / regulator assembly	• 3 feet (90 cm) within a height of 15 feet (4.5 m) above the meter /regulator assembly *
<b>I</b>	Clearance to service regulator vent outlet	• 3 feet (90 cm) **
<b>J</b>	Clearance to nonmechanical air supply inlet to building or the combustion air inlet to any other appliance.	• 6 inches (15 cm) for appliances <10k BTUh (3 kWh) • 9 inches / 22.5 kWh for appliances 10k < X <50k BTUh (3 < X <15 kWh) • 12 inches (30 cm) for appliances > 50k BTUh (15 kWh) **
<b>K</b>	Clearance to a mechanical air supply inlet.	• 3 feet (90 cm) above if within 10 feet (3m) horizontally **
<b>L</b>	Clearance above paved sidewalk or paved driveway located on public property.	• 7 feet (2.1 m) <sup>3</sup>
<b>M</b>	Clearance under veranda porch, deck or balcony	• 12 inches (30 cm) <sup>3</sup>
<b>N</b>	Depth of alcove (Maximum)	• 6 feet (1.8 m)**
<b>O</b>	Clearance to termination (alcove)	• 6 inches (15 cm)**
<b>P</b>	Width of alcove (Minimum)	• 3 feet (90 cm)*
<b>Q</b>	Clearance to combustible above (Alcove)	• 18 inches (45 cm)**
<b>R</b>	Top and bottom clearance from air inlet	• 3 feet (90 cm)
<b>S</b>	Side clearance from air inlet	• 9 inches (22.5 cm)
<b>T</b>	Side distance from ventilated soffit	• 6 inches (15 cm)

**Table 10.2**

<sup>1</sup> In accordance with the current CSA-B149.1 National Gas and propane installation code.

<sup>2</sup> In accordance with the current ANSI SZ223.1/NFPA 54 National fuel gas codes.

<sup>3</sup> A vent shall not terminate directly above a sidewalk or paved driveway which is located between two single family dwellings and serves both dwellings.

<sup>4</sup> Only permitted if veranda, porch, deck or balcony is fully open on a minimum 2 sides beneath the floor.

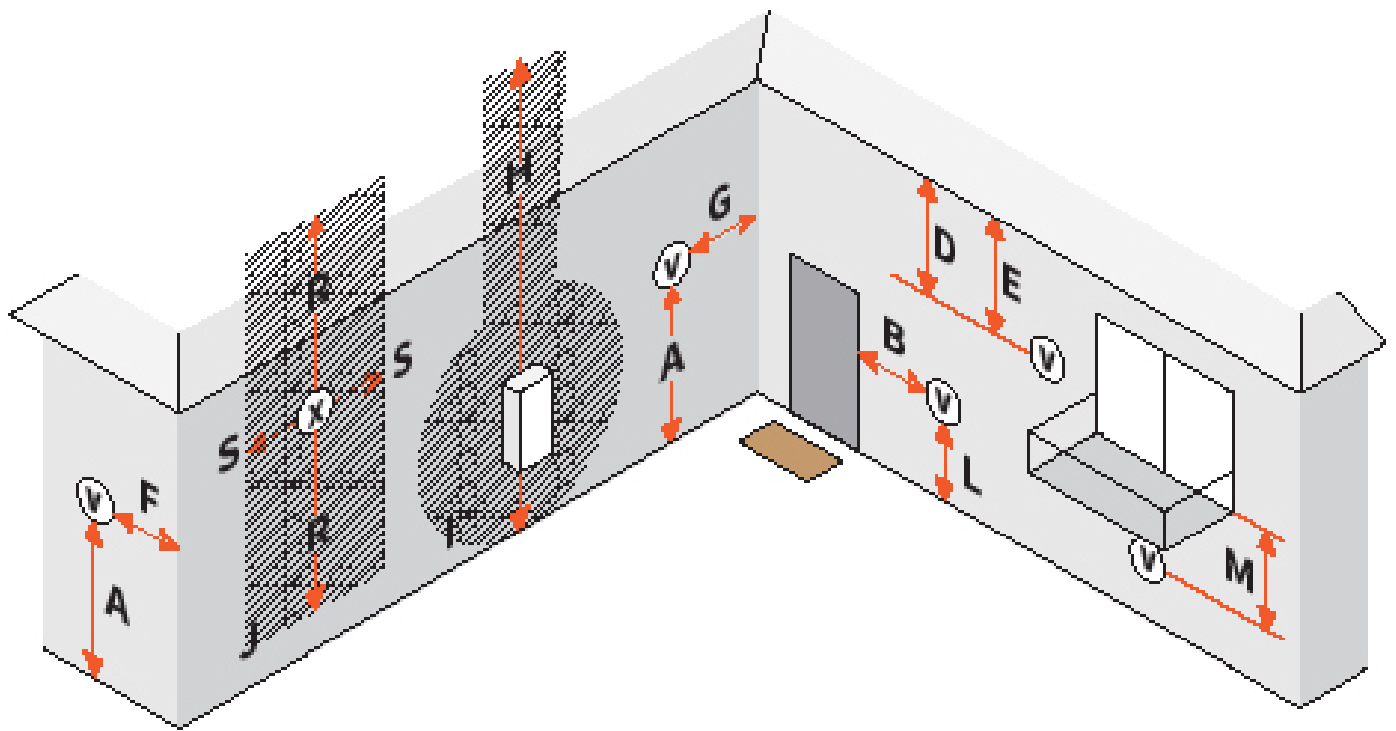

Figure 10.3 - horizontal vent termination I

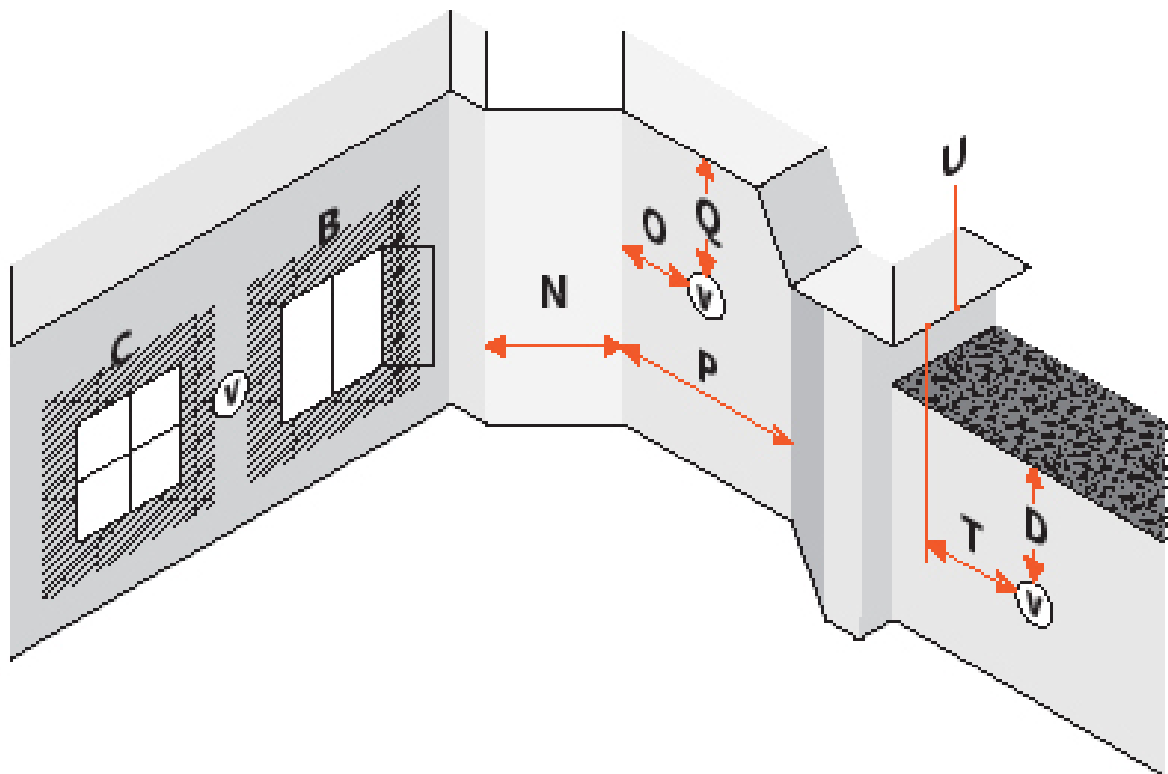

Figure 10.4 - Horizontal vent termination II

**11 MAINTENANCE INSTRUCTION**

This part of the manual focuses on the maintenance of your fireplace.

**Please note** It is recommended that you have the appliance inspected annually by a recognized installer, service agency or gas supplier to ensure safe use and a long service life.

**TURN OFF THE GAS BEFORE SERVICING THE APPLIANCE.**

**11.1 Maintenance in the combustion chamber**

During maintenance the glass windows of the fire need to be removed. To do this follow the following steps:

**11.1.1 Disassembly of the safety screen**

One of the safety features of the fireplace is the safety screen covering the windows. Any safety screen or guard that is removed for servicing must be replaced before operating the fireplace.

The safety screens are disassembled as by following the next steps

- Remove the safety screen(s) from their holders. The safety screens are held by magnets (**Figure 11.3**).
- Remove the lower magnet tabs from between the bottom trim and the front windows (**Figure 11.2** and **Figure 11.4**)
- Remove the upper magnet tabs from the back of the frame, so they are not in the way when removing the window.

To reassemble the safety screens reverse the steps. Make sure the lower tabs are secured properly between the window and trim.

**Safety screens parts**

	Upper Tabs	Lower Tabs	Magnets	Long Screens
<b>Sky LRD</b>	4	12	20	2
<b>Sky MRD</b>	4	12	20	2
<b>Sky SRD</b>	4	12	12	2

Table 11.1

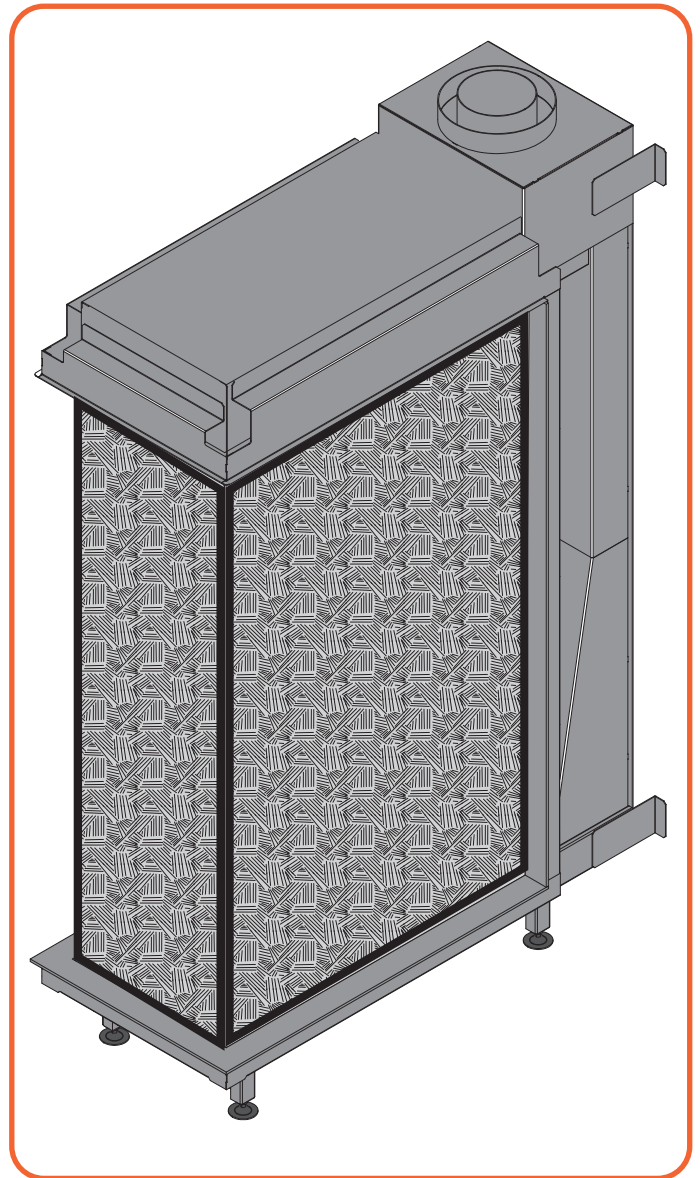

Figure 11.1 - Isometric Illustration

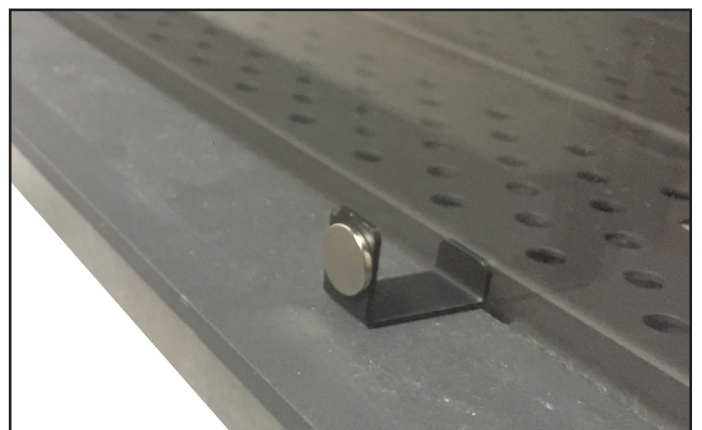

Figure 11.2 - Screen tab installed at the bottom trim

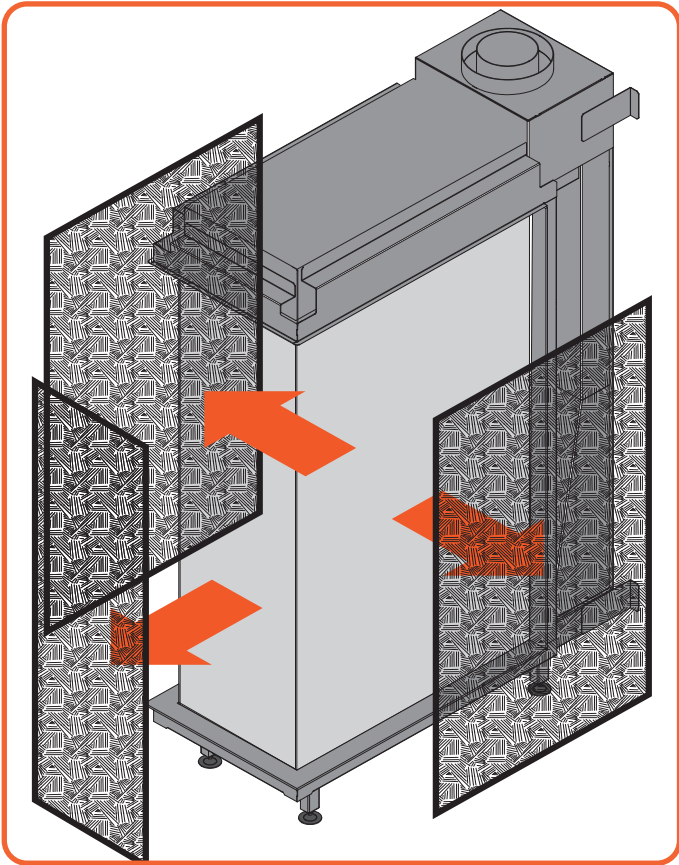

Figure 11.3 - Remove safety screens for tunnel model

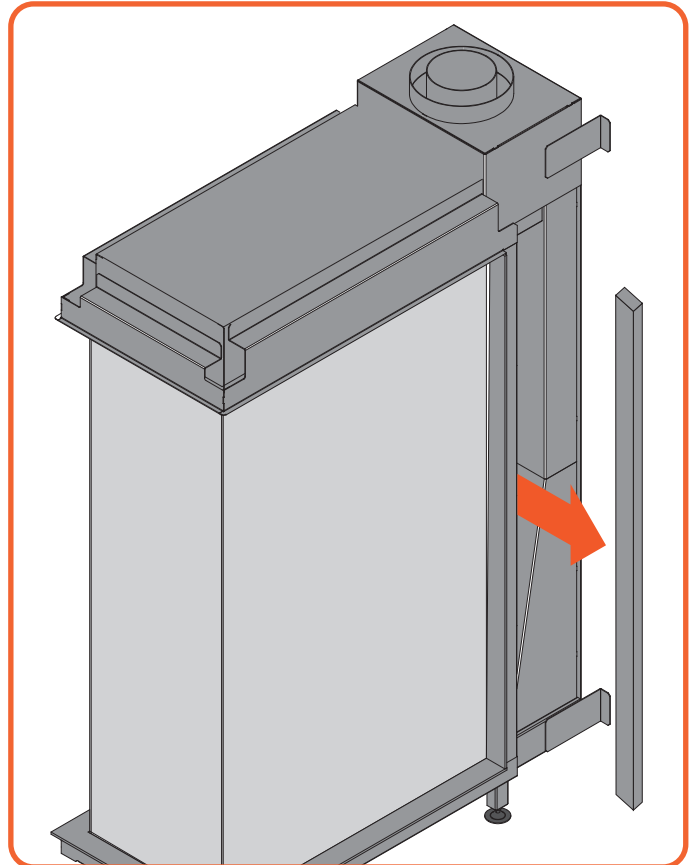

Figure 11.5 - Remove side trims

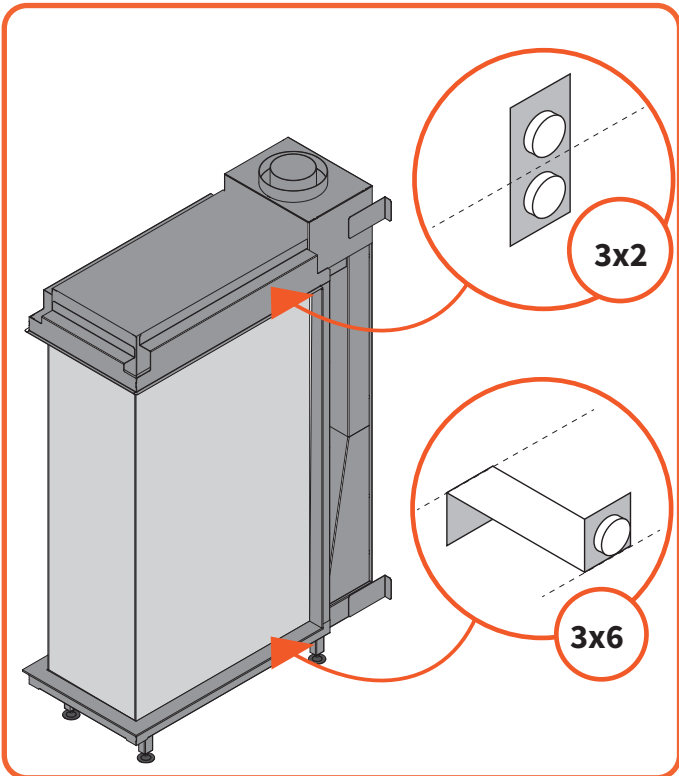

Figure 11.4 - Remove Magnets

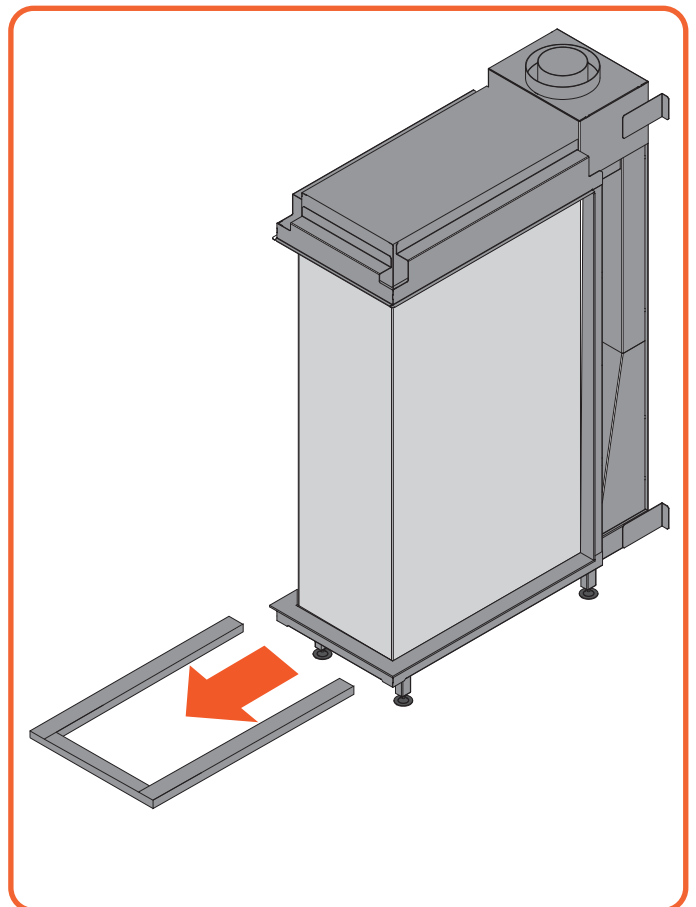

Figure 11.6 - Remove bottom trim

### 11.1.2 (Dis)assembly of the trims

For a tight finish of the fireplace, trims are provided. During maintenance these trims must be removed, before the glass can be removed. Please follow these steps:

#### Disassemble

- Remove both the side trims and bottom trim. They are held by magnets, **Figure 11.5** & **Figure 11.6**.

#### Assembly:

- Put the trims back in reversed order.

### 11.1.3 Remove glass

To be able to clean the glass on the inside, one needs to remove the glass.

#### Warning

The glass must be handled by a qualified person. As a safety precaution gloves should be worn when removing the glass.

To remove the glass follow these steps:

- Check, whether the trims are removed in as in **Chapter 11.1.2**.
- Put the section cup on the glass and make sure it is properly vacuumed, so it will not come off. (See **Figure 11.7**)
- Rotate the glass quick clamps out of the way while supporting the window
- Lift the glass out of the lower glass rail and tilt it out through the opening, as seen in **Figure 11.8**.

**Note:** Put the glass in a safe place when it is not in use to ensure it doesn't get damaged during maintenance. Detach the suction cup after removal to avoid leaving a mark on the glass.

#### Warning

It is important NOT to remove the end piece of glass as this is part of the chassis and integral to the structure and load bearing of the appliance. Only the two larger side pieces of glass should ever be removed.

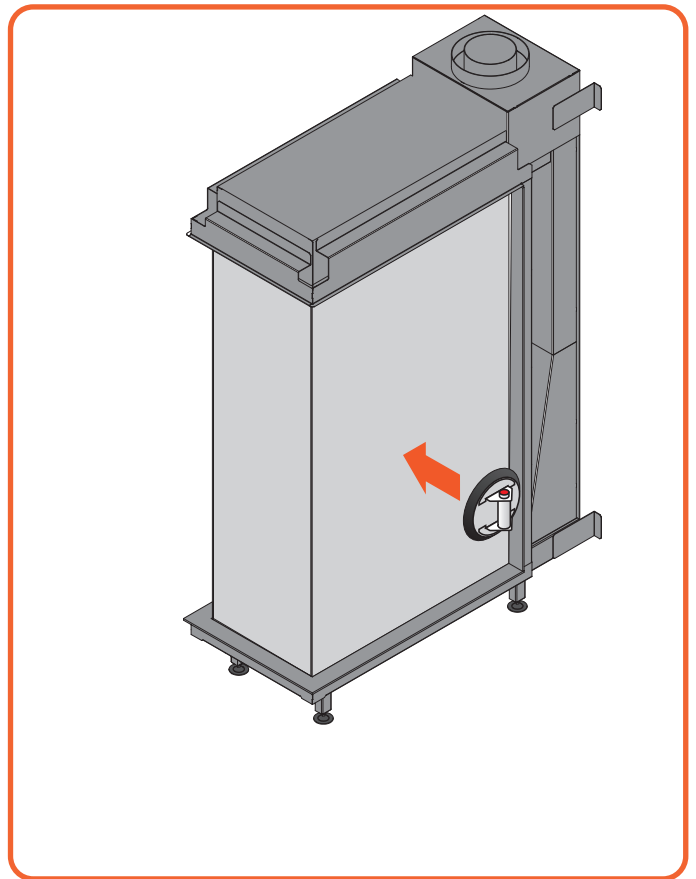

Figure 11.7 - Put on suction cups

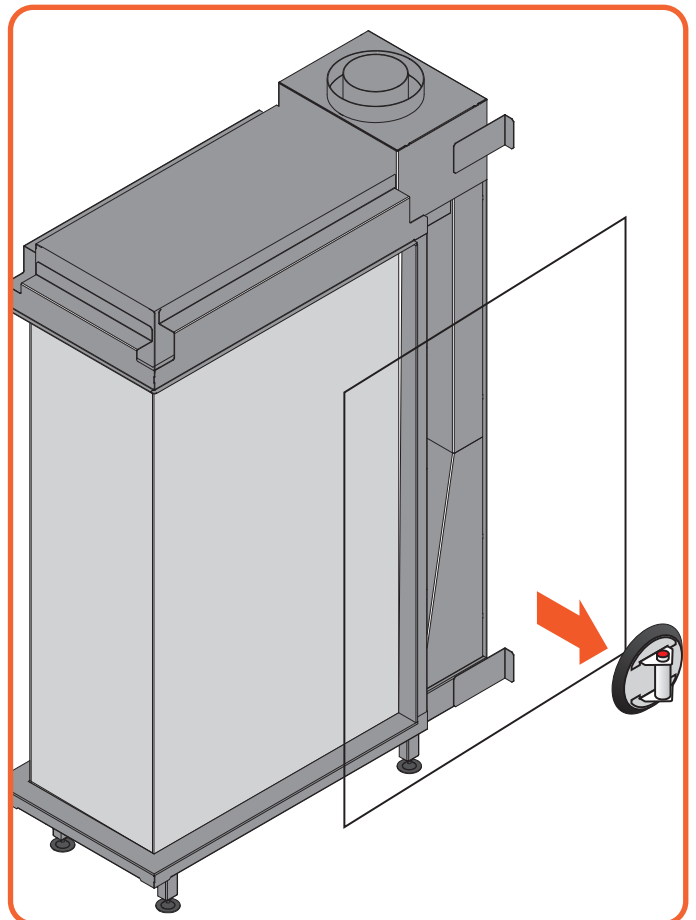

Figure 11.8 - Remove glass

## 11.2 Glass Maintenance

### 11.2.1 Ceramic glass

Burning natural gas (NG) or propane (LP) in this fireplace will always result in some of the gas components being deposited on the glass. Hydrogen sulfides and mercaptans, which are present in the burning gas, condense onto the relatively cooler glass surface and cause white film to build up over time.

The amount of this white film is influenced by a number of factors such as;

- the configuration of the system venting
- thermal efficiency of the fireplace design
- the humidity of combustion air
- frequency of fireplace use
- burner performance
- the fireplace design itself.

Do not use normal (usually ammonia-based) household glass cleaners to clean the glass as these cleaners can leave a permanent stain. Only a gas fireplace glass cleaner should be used. The following products are recommended and proven suitable for use:

Brand	Product
Forrest Technical Coatings	Stove Bright® Gas Appliance Glass Cleaner
Imperial Manufacturing Group	Imperial Gas Fireplace Glass Cleaner
A.W. Perkins Co.	GFC™ Gas Fireplace Glass Cleaner

The fireplace glass should be cleaned before the fireplace is first lit and then after the fireplace has been through its four hour burn-in cycle. This will reduce potential build up on your glass.

Keep in mind the following instructions when cleaning glass:

- Always clean the glass at room temperature. Do not clean the glass when it is hot!
- Use cleaning supplies qualified by Element4 or the product stated above.
- When you clean your Anti-Reflective glass (see the next section), make sure you use this with the special Element4 cleaner, which is available only via Element4.
- Use only a microfibre cloth. Other materials such as kitchen towels, steel wool etcetera can cause scratches or damage the coating on the glass.
- Should there occur stains on the glass, remove them regularly, for they can burn the glass.
- If the glass becomes coated with deposits which cannot be removed the glass must be replaced.

### 11.2.2 Anti-Reflective glass (Additional rules for)

Anti-reflective glass for the gas fireplaces consists of polished ceramic glass on which metal oxide coating layers have been applied. The thickness of the coating is checked down to the nanometer to perfectly control the reflection level. The reflectance level of untreated glass is on average 8%, while an anti-reflective glass provides a reflection of only 0.7%. Thanks to the new coating technology, anti-reflective glass is completely invisible when approached straight ahead. This gives the gas fireplace a super realistic fireplace effect. In this way you use all the advantages of a gas fire, while the atmosphere and warmth nevertheless match the fireplace.

For anti-reflective windows it is of great importance to observe certain maintenance instructions. In order not to damage the coating layers, the use of hard (sanding) sponges, abrasives and cleaning agents with ammonia is prohibited. Only use a neutral cleaning product (neither acidic nor alkaline), such as Element4 window cleaner (Item No. 4500926). The cleaning agents that you normally use should therefore not be used with an anti-reflective glass. Use a soft cloth or sponge (not paper).

Just as with ordinary ceramic glass, the white haze that results from the first combustion must be removed with anti-reflective glass. After that, sporadic maintenance is sufficient. Always rub the window completely dry. Residual water can stain the coating. Fingerprints are more visible on anti-reflective glass, therefore wear (rubber) gloves when grasping the window. If the window is lifted with a suction cup, the rubber of the suction cup must be dry to avoid damage to the coating.

### 11.2.3 Optional black glass installation

As an option for the fires of Element4, a black glass interior is available. To install these glass panels follow the next steps:

1. Remove fireplace trim and exterior glass following instructions shown previously in the manual.
2. Remove fire media from hearth tray so as it is not in the way.
3. Using provided suction cups, remove side panels from unit by lifting up and then swinging out the bottom of the panel first then once it is cleared from the bottom channel it should slide out enough to remove it. If you have a Sky Front the same step is for the back panel of the unit.
4. Replace the removed panels with the black glass panels by inserting the top of the panel in the channel first and then rotating the panel upright to bring the bottom of the panel into the bottom channel. Do this with both side panels and then the back panel if you have a Sky Front unit.
5. Replace the fire media on the hearth tray
6. Replace the glass and fireplace trim.

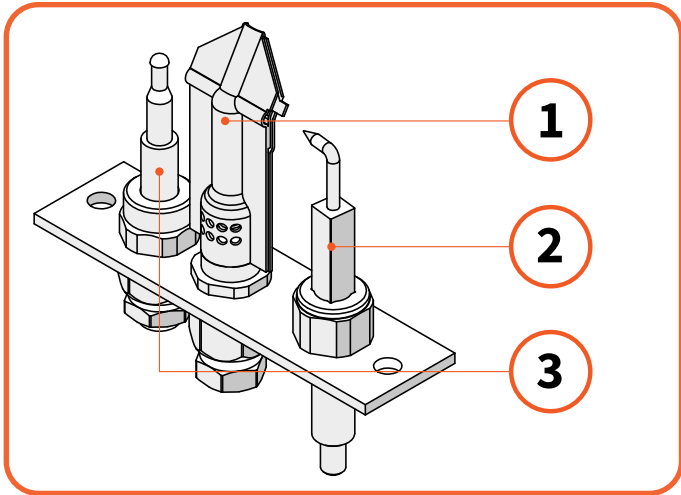

Figure 11.14 - Isometric drawing of the pilot set

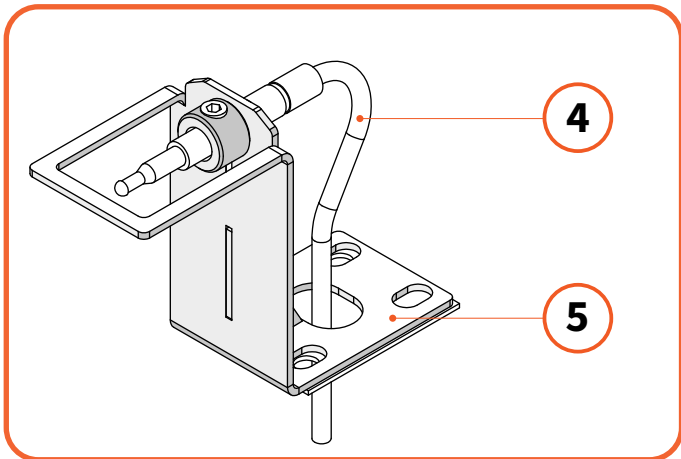

Figure 11.15 - Isometric drawing of second thermocouple

### 11.3 Burner Maintenance

For the maintenance of the burner different parts can be distinguished, all mentioned below. See **Figure 11.14** and **Figure 11.15** and **Table 11.2** for more info.

#	Part
1	Pilot flame
2	Ignitor Rod
3	Primary Thermocouple
4	Second Thermocouple
5	Thermocouple mount

Table 11.2

#### 11.3.1 Burners

The flames from the burners should be visually checked. The flame should have a small blue base and be bright yellow. Too orange flames indicate too little oxygen. Flames that are too blue have too much oxygen. The oxygen in the primary air can be adjusted slightly at the venturi throttles, but this should not be necessary.

Maintenance of the burner should also be unnecessary. If this is the case, check the burner pressure at the inlet to the burner. The instructions of changing the burner pressure and the correct pressure per gastype can be found in **CHAPTER 13.1**.

#### 11.3.2 Pilot

The pilot flame must be visually checked. The pilot flame must always be present when the appliance is in operation and should appear as shown in **Figure 11.14**.

The pilot has two distinct flames, one engulfing the thermocouple on its left, the other reaching across to the burner.

The area around the pilot should be inspected for cleanliness. Lint or foreign material must be removed with a brush or vacuum.

#### 11.3.3 Thermocouples

The Element4 fireplaces have two thermocouples; one next to the pilot and one opposite the pilot side of the burner. The completeness and operation of both must be checked. A qualified installer must confirm that both thermocouples are in place and undamaged. While checking the pilot set, please ensure that the ignitor rod is not cracked as well.



## 12 INSTALLING THE FIRE MEDIA

This appliance is equipped with a ceramic fire bed with heat resistant ceramic fibers. Excessive exposure to this material may cause irritation to the eyes, skin and respiratory tract. It is therefore recommended that the dust emission is reduced as much as possible when handling these materials.

Only the decorative media supplied with this appliance are to be used. The ceramics must be laid only as shown in this chapter. Replacement parts are available from your dealer, but should only be installed by a qualified installation engineer.

Position the decoration media as shown on the images in this chapter.



Figure 12.1 - Log set for the Sky fireplaces

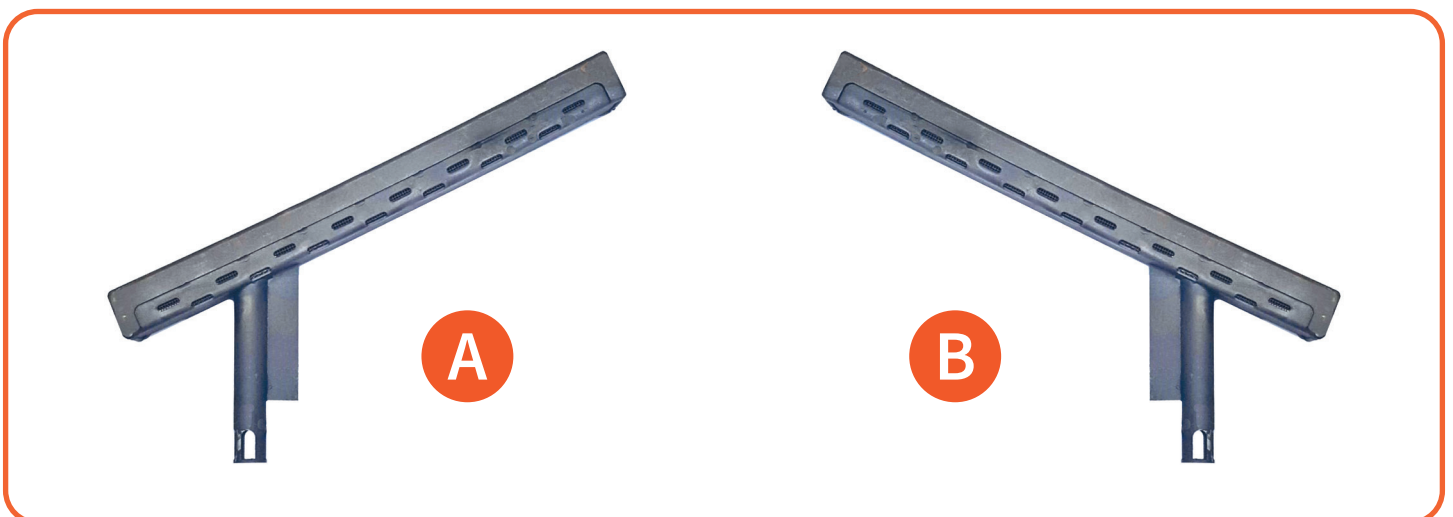

Figure 12.2 - Example of the log burners

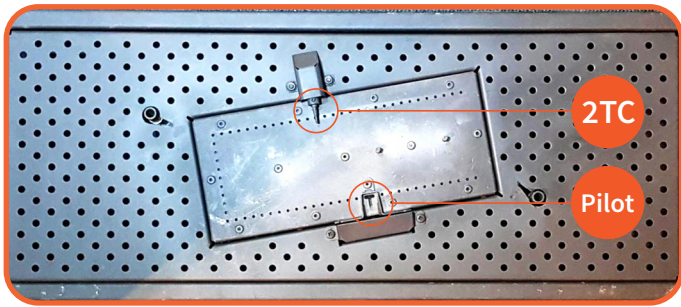

Figure 12.3 - Position of the safety thermocouples

Figure 12.3

Make sure that the pilot flame area and the second thermocouple are always free of any decorative material to make certain that the fire will ignite without problems.

Not doing so may cause a delayed ignition!

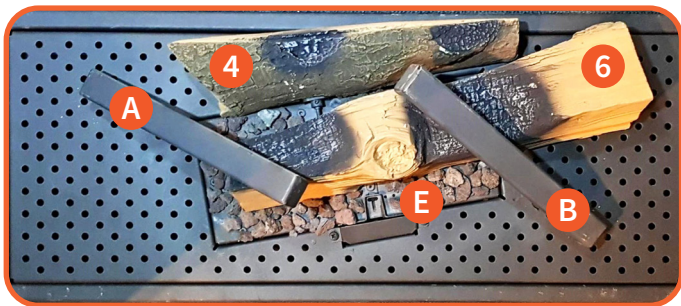

Figure 12.4 - First part of the media installation

Figure 12.4

- Position log number 6 on the flat burner and cover the rest of the flat burner area with the lava stones (E).
- Then place the log burners (A and B) in their respective holes. Ensure the burner is pressed through completely.
- Finally place log number 4 over the second thermocouple cap. The log is provided with a notch to help position it perfectly.



Figure 12.5 - Second part of the media installation

Figure 12.5

- Position logs number 2 and 5 on the log burners. In the bottom of the logs, there is a notch that will keep them in place. Make sure that the logs are completely over the burner.
- Put logs 1 and 3 on the burner grate. For the best look, let them overlap a little.



Figure 12.6 - Top view after media is installed

Figure 12.6

- Cover the burner grate with the rest of the decorative materials (C and D). Place the grey chips around the logs and the black chips on the sides.
- Double check that none of the decorative material is blocking the safety mechanisms (Pilot & thermocouples).

13 TECHNICAL DATA

This product was tested and listed to ANSI Z21.11.50a-2008 and CSA2.22a-2008 “Vented Gas Fireplaces” by Intertek Group (Figure 13.1).

A sample listing label image is shown above. A metal listing label is attached to every Element4 fireplace and contains important certification information e.g. it specifies for which type of gas, gas pressure and for which country this appliance is intended. The nameplate is attached to a chain.

**The listing label must not be removed from the fireplace.**

**Note:** Check whether the appliance is suitable for the gas type and gas pressure on site.

13.1 Gas specifications

<b>Model</b>		Sky LRD, MRD, SRD	
<b>Gas</b>		<b>Natural Gas</b>	<b>Propane</b>
<b>Input Maximum</b>	Btu/hr	54,000	37,500
<b>Input Minimum</b>	Btu/hr	10,000	8,500
<b>Inlet Pressure</b>	in. w.c.	7	10,5
	kpa	1.74	2.62
<b>Manifold Pressure</b>	in. w.c.	6	8
	kpa	1.49	1.99
<b>Main Burner Injector Size</b>		380 (x2) 320 (x1)	140 (x2) 120 (x1)
<b>Pilot Injector Size</b>		32.2	27.1
<b>New Efficiency</b>		90%	

13.2 Electric Specification

AC ADAPTER SPECIFICATIONS

<b>Input Voltage</b>	120V AC
<b>Input Power</b>	9 W
<b>Output Voltage</b>	6V DC
<b>Output Current</b>	500 mA
<b>Size</b>	3.1”H x 2”W x 1.7”D
<b>Output Cord Length</b>	6 Feet
<b>Agency Approvals</b>	UL, CSA

**DO NOT REMOVE LABEL  
NE PAS RETIRER CE LABEL**

**Manufacturer/ Fabricant:**  
Element4 B.V.  
Simon Stevinweg 6A  
NL-8013 NB Zwolle  
The Netherlands / Les Pays-Bas  
Tel / Tél : +31 38 4209020



Approved By / Approuvé par:



**VENTED GAS FIREPLACE - Not for use with solid fuel.**  
This appliance is only for use with the type of gas indicated on the rating plate and may be installed in an aftermarket, permanently located, manufactured home (USA only) or mobile home where not prohibited by local codes. See owner's manual for details. This appliance is not convertible for use with other gases, unless a certified kit is used. For use only with Vent, Glass Panels and Ceramic Logs (or stones) certified and approved for use with this appliance. This appliance must be installed in accordance with local codes, if any; if none, follow ANSI Z223.1/NFPA 54, or CSA B149.1. The appliance must be properly connected to a venting system in accordance with the manufacturer's installation instructions. The system must be installed by a qualified installing agency.

**FOYER AU GAZ À ÉVACUATION - Ne pas utiliser avec un combustible solide**  
Cet appareil est destiné uniquement avec le type de gaz indiqué sur la plaque signalétique et peut être installé dans une habitation en dur, à emplacement fixe (USA uniquement) ou dans une résidence mobile si la législation locale l'autorise. Consultez le manuel du propriétaire pour les détails. Cet appareil ne doit pas être modifié pour une utilisation avec d'autres gaz, sauf à l'aide d'un kit certifié. À utiliser uniquement avec des ventilations, panneaux en verre et poutres (ou pierres) en céramique dont l'utilisation est autorisée avec cet appareil. Cet appareil doit être installé conformément à la législation locale. À défaut d'une telle législation, suivre ANSI Z223.1/NFPA 54, ou CSA B149.1. L'appareil doit être proprement raccordé à un système de ventilation, conformément aux instructions d'installation du fabricant. Le système doit être installé par un installateur qualifié.

<input type="checkbox"/> Natural Gas Gaz naturel	<input type="checkbox"/> Propane Gas Gaz Propane	<b>Clearances to combustible / Dégagements aux combustibles :</b>
54000	37500	Back / Arrière : 11 " 28 cm
10000	8500	Top / Haut : 26 " 66 cm
7	11	Mantel / Linteau : 2 " 5 cm
6	10,5	Sides / Côtés : 11 " 28 cm
4	8	Floor / Sol : 4 " 10 cm
2x380, 1x320	2x140, 1x120	

**Control No. :** 4006611  
**Conforms to / Conforme à:**  
ANSI Z21.50 - Vented Gas Fireplace  
**Certified to / Certifié à:**  
CSA 2.22 - Vented Gas Fireplace  
CAN/CGA 2.17 - M91

**Product name / Nom du produit**  
 Sky LRD  
 Sky MRD  
 Sky SRD

**Fuel Type / Type de combustible**  
Max. Input / Capacité d'entrée maxi (BTU/HR)  
Min. Input / Capacité d'entrée mini (BTU/HR)  
Gas Inlet Pressure ("WC) / Pression d'entrée du gaz (po WC)  
Manifold Pressure ("WC) / Pression d'admission (po WC) | up to / jusqu'à 2000ft/610m  
Manifold Pressure ("WC) / Pression d'admission (po WC) | up to / jusqu'à 4500ft/1370m  
Orifice Size / Taille de l'ouverture

**Equipped only for altitudes / Équipé uniquement pour les altitudes :** 0-4500 ft / 0-1370 m

**Serial No. / N° de série:** \_\_\_\_\_

Figure 13.1 - Example of the data plate

## 14 OPERATING THE FIREPLACE

### 14.1 Before the first fire

1. Make certain that all construction materials have been removed from inside and around the fireplace and the fireplace has been cleaned of any construction dust. Clean the glass BEFORE and AFTER the first fire.
2. Confirm that the gas valve is properly connected and bled by a certified gas technician or plumber.
3. Check the gas supply for leaks and proper pressure. Refer to the table in "Appliance Ratings" section.
4. Check that the venting is unobstructed and in proper working condition.
5. Clean the glass panels on both sides.
6. Properly place, clamp and seal the glass panels.
7. Ensure the receiver is powered with an AC Adapter OR Batteries, but not both!

Place the two (2) AAA batteries into the remote control and confirm that it will communicate with the receiver by pressing the ON/OFF button. Pair the remote and receiver (see **CHAPTER 4.1.1**).

### 14.2 The first fire

When the fireplace is first heated, an odor may be given off by the hot metal. This is normal and is a result of the 'burn off' of the lubricants and sealants used when manufacturing the fireplace.

It is recommended that you open the nearby windows for extra ventilation and then operate the fireplace for at least four hours.

Because a fireplace is a heat source, natural convection will occur around it. Solid particles in the circulating air may burn and settle down on cold surfaces, causing discoloration. Discoloration is an annoying problem and it is difficult to solve.

These particles can come from construction moisture or cigarette smoke, but also they might be volatile components in paint, construction materials or carpeting. For newly constructed chimneys or after a big reconstruction, it is advised to wait a minimum of six weeks before firing a fireplace. After this burn-off period, turn off the fireplace and let it cool completely to room temperature and once again clean both sides of the glass and the interior panels as described in **CHAPTER 11.2**.

When the glass is cold, some condensation may appear on the glass after lighting the fireplace. This is normal and the condensation will disappear as the glass warms.

To ensure as little condensation as possible, the fireplace will start on just the main burner. During the first minute of firing this will ensure your fireplace to evaporate the condensation on the glass and heat up the air in the combustion chamber.

**Please note** During the first minute of firing i.e. the initial start up sequence of lighting the pilot flame and the first 30 seconds until the second thermocouple has given its clear, it is not possible to use the 'double plus'-button to switch between burners.

During this first fire, examine the flame for appearance and quality. Examine the burner media for sooting. Flames may appear blue and will turn yellow after 15 to 20 minutes.

Since it is a metal fireplace, the heat-up and cool-down cycles may produce some noises caused by the expansion and contraction of these metals. The premium materials and build quality of your fireplace will keep these sounds to a minimum.

### 14.3 The first fire - testing

As a continuation of the previous chapter, prior to being placed into (daily) operation, the fireplace should be test-fired in stages to ensure that all components are in good working order.

This fireplace has a 2nd thermocouple which senses the burner flame. The system will turn itself off if the system does not sense the 2nd thermocouple output within 29 seconds after the valve opens.

If 2nd thermocouple is still hot enough to produce electricity at the receiver thus preventing the fireplace from starting, the remote will flash "OFF" to signal this safety lock out. Allow time for the 2nd thermocouple to cool down before attempting a start. The system is ready to start when the flashing "OFF" becomes solid on the remote and pressing the ON/OFF button produces a response from the valve.

1. Start the fireplace with the hearth panel out and with the front glass off. Ensure that the pilot flame both heats the primary thermocouple and lights the burner. For safety, a post-purge delay is built into the system. Subsequent start attempts MUST NOT take place for at least thirty (30) seconds.
2. Start the fireplace with the hearth panel in place and with all of the glass panels fixed correctly in place. Ensure that the main burner flames engulf the 2nd thermocouple and the fireplace stays lit for at least 1 full minute. If the system turns itself off after 29 seconds install the required media (next section) and return here. Installing the fire media will help with the flame around the 2nd thermocouple. Subsequent start attempts MUST NOT take place for at least five (5) minutes.
3. Start the fireplace with the media installed. If the system turns itself off after 29 seconds, rearrange the media to produce a good flame at the 2nd thermocouple. This step may have to be repeated several times before the media is in the best place for consistent operation. A single, long beep indicates that the 2nd thermocouple is still too hot to start the ignition sequence. Allow time for the 2nd thermocouple to cool down. Once the system stays lit for at least one full minute, turn the fireplace off, fix the glass panels in place and operate the fireplace for at least 45 minutes to ensure the system works properly when heated.

If the pilot is extinguished either intentionally or unintentionally no attempt should be made to re-light the gas until at least 3 minutes have elapsed.

15 ELECTRONICS

15.1 Electrical requirements

The Element 4 fireplaces use a receiver and remote control for their burner operation. The remote control comes with two AAA batteries and the receiver is powered by a 120V AC adapter, included. The fireplace MUST be powered by the AC adapter for improved reliability and customer satisfaction.

The installer must provide an approved 120V AC receptacle to be placed within the six foot cord limit of the AC adapter.

The receiver MUST be powered by the AC adapter. Four (4) AA batteries may be used only for on-demand electrical requirement during a power outage. Remove batteries after use to avoid battery corrosion. Battery corrosion will damage the receiver.

**Warning**

Electrical work must be performed by a qualified, licensed electrician. All wiring shall be in compliance with all local, city, and state codes.

15.1.1 Electrical grounding

These direct vent appliances must be electrically grounded in accordance with the local codes or, in the absence of local codes, with National Electric Code, ANSI/NFPA 70 or the Canadian Electric Code, CSA C22.1.

15.2 (Replacement) parts

Figure 15.1 shows a simplified connection circuit for the fireplace. Every fireplace is provided with a main adapter.

#	Description	Qt	Article number
(1)	Gas Valve	1	E4-GS-GV-01
(2)	Receiver	1	E4-GS-CM-Wifi-04
(3)	Main Burner		
(4)	Second Burner		
(5)	Third Burner		
(6)	Pilot assembly	1	E4-GS-PABT-01
(7)	2 <sup>nd</sup> Thermocouple	1	E4-GS-2TC-01
(8)	Wifi-Box (optional)	1	E4-GS-Con-Wifi-02
(9)	Adapter 6V	1	AC Adaptor-03
	Remote Control	1	Repl-E4-GS-RC-10B-02

Table 15.1

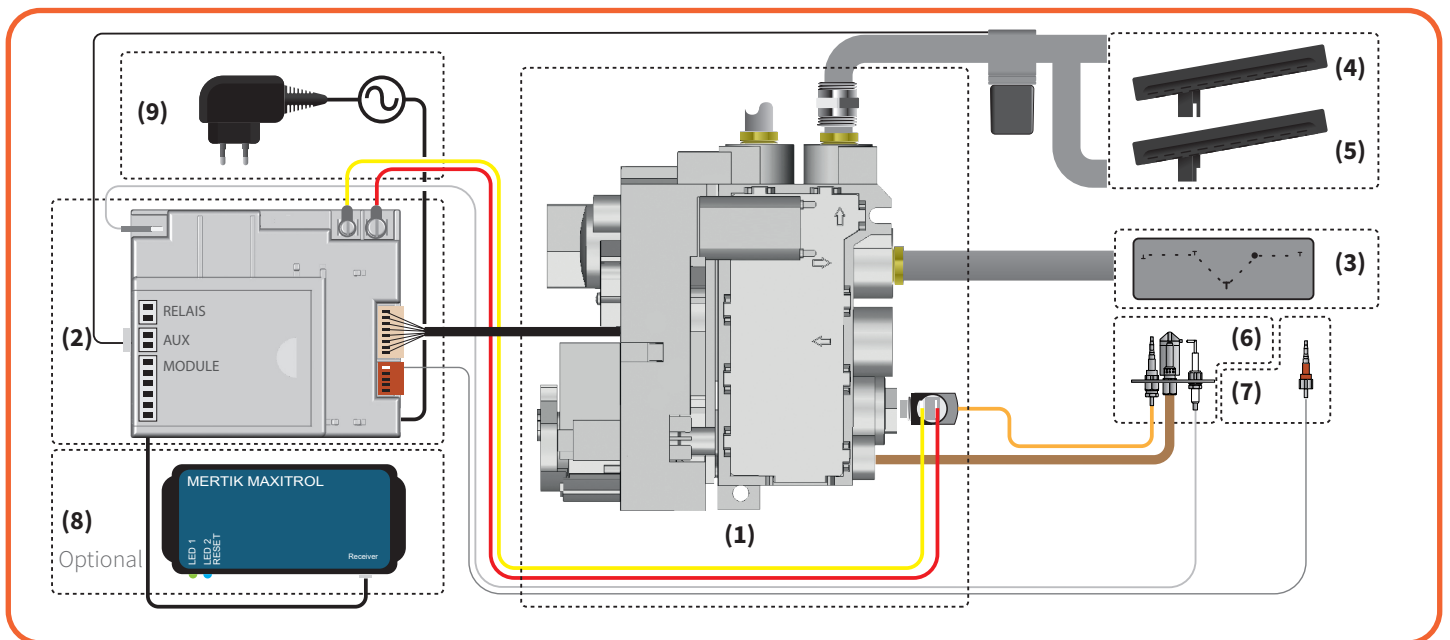



Figure 15.1 - Schematic Electronic Circuit

## 15.3 Remote control

The following pages contain detailed instructions about the functions of the 10 button remote.

Software Version



Press  and  buttons simultaneously. Software version is displayed.

Remote Model Number

Press  and  buttons simultaneously. Remote model number is displayed.

### 15.3.1 Activating/Deactivating Functions

The following functions can be disabled on the remote:

- CHILD PROOF (To activate press  and  buttons simultaneously.  displayed and the remote is rendered inoperable (except for off function).
- PROGRAM MODE
- THERMOSTATIC MODE (also deactivates Program Mode)
- ECO MODE
- LIGHT/DIMMER OPERATION
- CIRCULATING FAN OPERATION
- AUXILIARY FEATURE
- COUNTDOWN TIMER

If a deactivated button is pressed, there is no function, and two horizontal bars are displayed. Deactivation remains in effect after change of batteries.

#### To Deactivate a function:

1. Install batteries. All icons are displayed and flashing.
2. While the icons are flashing, press the relevant function button and hold for 10 sec.
3. The function icon will flash until deactivation is complete. Deactivation is complete when the function icon and two horizontal bars are displayed.

#### To Activate a function:

1. Install batteries. All icons are displayed and flashing.
2. To activate a function, press the relevant button and hold for 10 sec.
3. The function icon will continue to flash until activation is complete. Activation is complete when the function icon is displayed.

### 15.3.2 Automatic Turndown.

In Manual/Temperature/Timer modes, the valve will turn to pilot flame if there is no change in flame height for a six hour period. In Temperature or Timer mode, if the ambient room temperature changes, the flame height will adjust automatically to maintain set temperature and the fire will continue to function normally. The valve will turn to pilot flame if the set temperature and the ambient room temperature remain the same over a six hour period.

2. The valve turns to pilot flame if the temperature in the receiver is higher than 140°F/60°C. The burners comes back on only when the temperature is below 140°F/60°C.

### 15.3.3 Automatic Shut Off.

1. With low battery power in the receiver, the system shuts off the fire completely. This does not happen if the power supply is interrupted.

2. The system shuts off the fire completely if there is no change in flame height for 5 days.

3. The system shuts off the fire if the main burner does not completely ignite approximately 29 seconds after ignition or after pushing the  button.

10 BUTTON REMOTE CONTROL

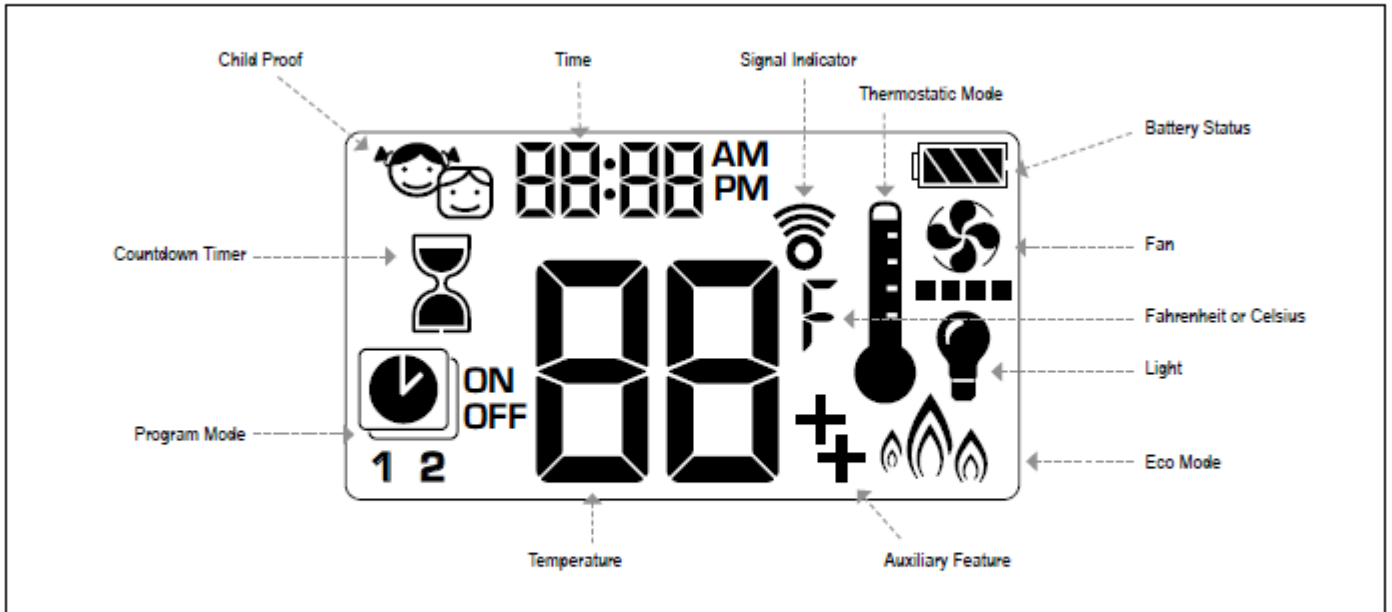

SETTING FAHRENHEIT or CELSIUS



To change between °C and °F, press and buttons simultaneously.

**NOTE:** Choosing °F results in a 12 hour clock. Choosing °C results in a 24 hour clock.

CHILD PROOF



**ON:**  
To activate press and buttons simultaneously. displayed and the handset is rendered inoperable, except for the off function.

**OFF:**  
To deactivate press and buttons simultaneously. disappears.

SETTING the TIME



1. Press and buttons simultaneously. Day flashes.
2. Press or button to select a number to correspond with the day of the week (e.g. 1=Monday, 2=Tuesday, 3=Wednesday, 4=Thursday, 5=Friday, 6=Saturday, 7=Sunday).
3. Press and buttons simultaneously. Hour flashes.
4. To select hour press or button.
5. Press and buttons simultaneously. Minutes flash.
6. To select minutes press or button.
7. To confirm press and buttons simultaneously or wait.

MANUAL MODE (HANDSET)

**NOTICE**

**BEFORE OPERATING**

1. Make sure MANUAL knob on the GV60 valve is in the ON, full counterclockwise position.
2. Place the ON/OFF switch (if equipped) in the I (ON) position.

TO TURN ON FIRE

**▲ WARNING**

When pilot ignition is confirmed, motor turns automatically to maximum flame height.



**Handset One-Button Operation**  
(Default Setting)

- Press **⏻** button until two short beeps and a blinking series of lines confirms the start sequence has begun; release button.
- Main gas flows once pilot ignition is confirmed.
- Handset automatically goes into Manual Mode after main burner ignition.

**NOTICE**

Change from one-button to two-button ignition operation by pressing and holding **⏻** button for 10 sec. immediately after installing batteries. **ON** is displayed and **1** is flashing. When change is complete **1** will change to **2**.



**Handset Two-Button Operation**

- Press **⏻** and **▲** button simultaneously until two short beeps and a blinking series of lines confirms the start sequence has begun; release buttons.
- Main gas flows once pilot ignition is confirmed.
- Handset automatically goes into Manual Mode after main burner ignition.

**NOTICE**

Change from two-button to one-button ignition operation by pressing and holding **⏻** button for 10 sec. immediately after installing batteries. **ON** is displayed and **2** is flashing. When change is complete **2** will change to **1**.

**FLAME HEIGHT ADJUSTMENT**



**Handset**

- To increase flame height press and hold **▲** button.
- To decrease flame height or to set appliance to pilot flame, press and hold **▼** button.

**DESIGNATED LOW FIRE and HIGH FIRE**

**NOTE:** Backlight must be on for high fire and low fire double-click operation.



- To go to low fire, double-click **▼** button. **LO** is displayed.

**NOTE:** Flame goes to high fire first before going to low fire.



- To go to high fire, double-click **▲** button. **HI** is displayed.

**STANDBY MODE (PILOT FLAME)**

**Handset**

- Press and hold **▼** button to set appliance to pilot flame.

**TO TURN OFF FIRE**



**Handset**

- Press **⏻** button to turn off.

**NOTE:** There is a 5 sec delay before the next ignition is possible.

**COUNTDOWN TIMER**



**ON/SETTING:**

1. Press and hold **⏻** button until **⏻** displayed, and hour flashes.
2. To select hour press **▲** or **▼** button.
3. To confirm press **⏻** button. Minutes flash.
4. To select minutes press **▲** or **▼** button.
5. To confirm press **⏻** button or wait.

**OFF:**

Press **⏻** button, **⏻** and countdown time disappear.

**NOTE:** At end of countdown time period, the fire turns off. The Countdown Timer only works in Manual, Thermostatic, and Eco Modes. Maximum countdown time is 9 hours and 50 minutes.



MODES OF OPERATION



**Thermostatic Mode**  
The room temperature is measured and compared to the set temperature. The flame height is then automatically adjusted to achieve the set temperature.



**Program Mode**  
Programs 1 and 2, each can be programmed to go on and off at specific times at a set temperature.



**Eco Mode**  
Flame height modulates between high and low. If the room temperature is lower than the set temperature, the flame height stays on high for a longer period of time. If the room temperature is higher than the set temperature, the flame height stays on low for a longer period of time. One cycle lasts approx. 20min.

THERMOSTATIC MODE



**ON:**  
Press **↓** button. **↓** displayed, preset temperature displayed briefly, and then room temperature displayed.

**OFF:**  
1. Press **↓** button.  
2. Press **▲** or **▼** button to enter Manual Mode.  
3. Press **Ⓜ** button to enter Program Mode.  
4. Press **Ⓜ** button to enter Eco Mode.



**SETTING:**  
1. Press **↓** button and hold until **↓** displayed, temperature flashes.  
2. To adjust set temperature press **▲** or **▼** button.  
3. To confirm press **↓** button or wait.

PROGRAM MODE



**ON:**  
Press **Ⓜ** button. **Ⓜ**, **1** or **2**, **ON** or **OFF** displayed.



**OFF:**  
1. Press **Ⓜ** or **▲** or **▼** button to enter Manual Mode.  
2. Press **↓** button to enter Thermostatic Mode.  
3. Press **Ⓜ** button to enter Eco Mode.

**NOTE:** The set temperature for Thermostatic Mode is the temperature for the on time in Program Mode. Changing the Thermostatic Mode set temperature also changes the on time temperature in Program Mode.

**Default settings:**  
ON TIME (Thermostatic) TEMPERATURE: 21 °C (70 °F)  
OFF TIME TEMPERATURE: "--" (pilot flame only)



**TEMPERATURE SETTING:**  
1. Press **Ⓜ** button and hold until **Ⓜ** flashes. **ON** and set temperature (setting in Thermostatic Mode) displayed.  
2. To continue press **Ⓜ** button or wait. **Ⓜ**, **OFF** displayed, temperature flashes.  
3. Select off temperature by pressing the **▲** or **▼** button.  
4. To confirm press **Ⓜ** button.

**NOTE:** The on (Thermostatic) and off set temperatures are the same for each day.



**DAY SETTING:**  
5. **ALL** flashes. Press **▲** or **▼** button to choose between **ALL**, **SRSU**, **1**, **2**, **3**, **4**, **5**, **6**, **7**.  
6. To confirm press **Ⓜ** button.

**RLL selected**



- ON TIME SETTING (PROGRAM 1):**
7. **ON**, **1 ON** displayed, RLL is displayed shortly, and hour flashes.
  8. To select hour press **▲** or **▼** button.
  9. To confirm press **⊙** button. **ON**, **1** displayed, RLL displayed shortly, and minutes flash.
  10. To select minutes press **▲** or **▼** button.
  11. To confirm press **⊙** button.



- OFF TIME SETTING (PROGRAM 1):**
12. **OFF**, **1 OFF** displayed, RLL is displayed shortly, and hour flashes.
  13. To select hour, press **▲** or **▼** button.
  14. To confirm press **⊙** button. **OFF**, **1** displayed, RLL displayed shortly, and minutes flash.
  15. To select minutes press **▲** or **▼** button.
  16. To confirm press **⊙** button.

**NOTE:** Either continue to PROGRAM 2 and set on and off times or stop programming at this point, and PROGRAM 2 remains deactivated.

**NOTE:** PROGRAM 1 and 2 use the same on (Thermostatic) and off temperatures for RLL, 5R5U and Daily Timer (1, 2, 3, 4, 5, 6, 7). Once a new on (Thermostatic) and/or off temperature has been set, that temperature becomes the new default setting.

**NOTE:** If RLL, 5R5U or Daily Timer are programmed for PROGRAM 1 and PROGRAM 2 on and off times, these become the new default times. The batteries must be removed to clear the PROGRAM 1 and PROGRAM 2 on and off times and temperatures.

**5R5U or Daily Timer (1, 2, 3, 4, 5, 6, 7) selected**

- Set on time and off time using same procedure as "RLL selected" (above).
- 5R5U: Set on time and off time for both Saturday and Sunday.
- Daily Timer: Unique on and off times may be set for a single day of the week, for multiple days of the week, or for every day of the week.
- Wait to finish setting.

**AUXILIARY FEATURE**

Upon ignition burner 1 is on and burner 2 is in the last setting.



- ON:**  
To switch a burner on, press the **⊕** button. **⊕** displayed.
- OFF:**  
To switch the burner off, press the **⊕** button. **⊕** disappears.

**AUTOMATIC TURN DOWN**

**3 Hour No Communication Function**

- The valve will turn to pilot flame if there is no communication between handset and receiver for a 3 hour period. The fire will continue to function normally when communication is restored.

**Receiver Overheating**

(only if module is connected)

- Valve turns to pilot flame if the temperature in the receiver is higher than 140°F (60°C). The main burner turns back on (manually or in Thermostatic Mode) only when the temperature is below 140°F (60°C).

**AUTOMATIC SHUT OFF**

**Countdown Timer**

- At end of countdown time period, the fire turns off. The Countdown Timer only works in Manual, Thermostatic, and Eco Modes. Maximum countdown time is 9 hours and 50 minutes

**Low Battery Receiver**

- With low battery power in the receiver the system shuts off the fire completely. This will not happen if the power supply is interrupted.

**On-Demand Pilot**

- This green feature eliminates gas energy consumption during extended appliance inactivity. When the appliance is inactive for an extended period of time the system automatically extinguishes the pilot. This feature helps the consumer realize cost benefits by automatically eliminating energy consumption during non-heating months and limited use.
- The programmed length of inactivity to activate the system is specified by the appliance manufacturer and cannot be altered in the field.

**2<sup>nd</sup> Thermocouple Shut Off**

- 2<sup>nd</sup> thermocouple Option: The system shuts off the fire if the main burner does not completely ignite approximately 20 seconds after ignition or after pushing **▲** button.

**NOTE:** Before the next ignition there is a 2 minute waiting period. If the thermocouple is then still too hot, you will hear a long beep.

**15.4 Element4 ProControl App.**

It is possible to operate your device via smartphone or tablet with the ProControl App, available in the appstore on iOS and google play on Android.

The app has a user friendly, interactive layout and the design is adjusted for Element4 devices. Up to eight devices can be used with one app, in the situation that multiple fires are installed in the same location.

Another functionality of the app is to pre-set the temperature of you device, for a period of one week, to ensure yourself of an optimal desired room temperature. Also the device can be changed between high and low flames and it features an eco-setting.

The amount of users, that can operate the device is unlimited, so every family member can make use of it, by easily making a personal account. By two-way communication, one can check on the device at any moment.

To use the app, the device needs to be provided with the correct receiver and remote combination.

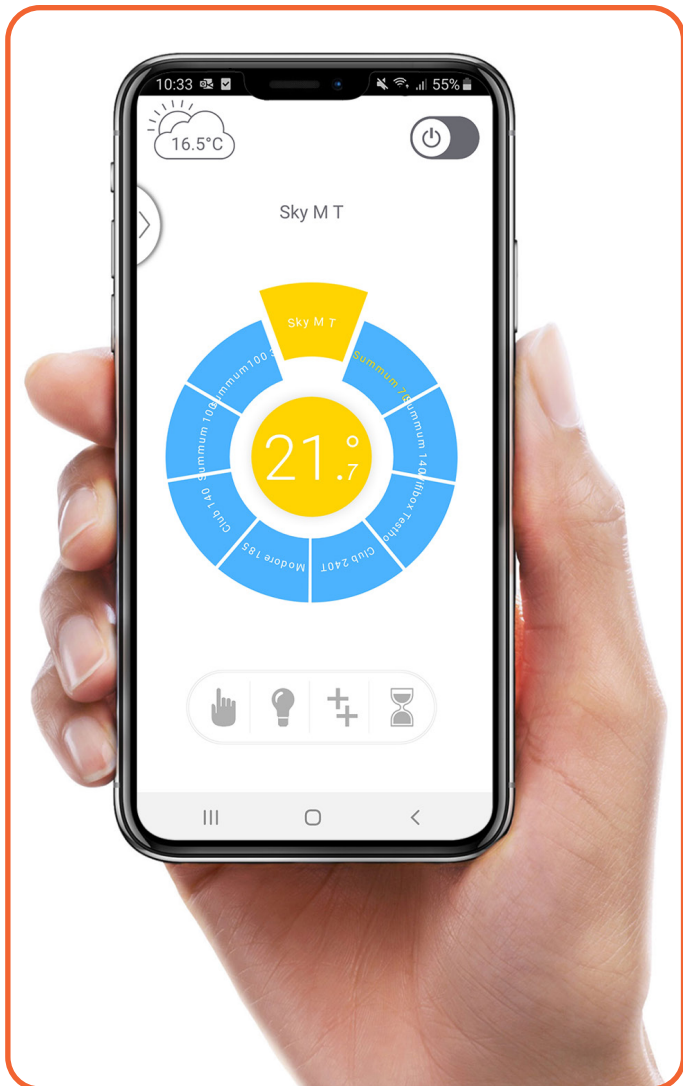

Figure 15.2 - The Pro control app

**15.4.1 Router information**

**Minimum requirements**

- Compatible with IEEE 802.11n / g / b
- WPA2 encryption
- Radio frequency 2.4 GHz band
- Wireless automatic channel: Automated search for WLAN radio channel that is free from interference.
- Support for the User Datagram Protocol (UDP)

Necessities for the installation of the ProControl:

- 220 volt electricity near the fire
- Wi-Fi code of the router
- Smart Phone or tablet
- ProControl manual
- Wifi box (8)

**Wi-Fi Router**

It is important to think carefully about the location of a router. This device spreads the wifi signal in and around your home. Therefore, preferably choose a central position. You prevent long distances from occurring.

Many people put the router in the meter cupboard, because that is where the internet comes in at many households. This however may not be the best choice.

For a powerful WiFi signal, the router needs as much space as possible. Therefore, do not place the device near a wall or on the ground. Some routers have multiple antennas that you can target. Try to spread these antennas so that you increase the range.

**15.4.2 Jammers**

Many devices also emit radio waves just like your router. These include microwave ovens, wireless doorbells, baby monitors, Bluetooth adapters, wireless music systems, DECT telephones and security cameras. These devices can disrupt your wireless network (interference), so the Wi-Fi connection is not optimal. Try to keep jammers as far away as possible from the router. Neighboring wireless networks also play a role in the Wi-Fi area.

**15.4.3 Frequency**

By default, most routers use the 2.4 GHz band to broadcast the Wi-Fi signal. The disadvantage is that this frequency band is very busy, so that there is quickly interference. There are a lot of competing users and jammers using the same radio waves. Since most "older" laptops, smartphones, tablets and other devices can not connect via the 5GHz band, the ProControl module is not suitable for 5GHz band.

Should any problems occur with the ProControl application you can always check **APPENDIX B**.

15.5 Connecting to a smart home system

15.5.1 General notes

The fireplace may be operated through an external source such as a smart home (home automation) system by using the 5-pin connector on the receiver (Smart Home System Cable Type: G60-ZCE).

A required 39" (990 mm) cable, with connector, is available (p/n E4-SA-SHSC-02). The overall cable length should not exceed 26' (7925 mm.)

Signal relays (gold contacts) or opto-couplers are recommended but not supplied. The E4-SA-SHSC-02 cable must be connected to the three smart home system contacts as shown below.

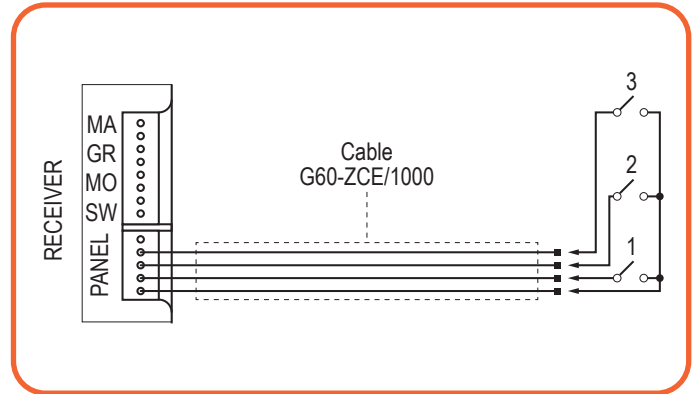

Figure 15.3 - Operation sequence overview

**Warning:** you must ensure that the fireplace is in a safe and secure environment before attempting to operate it from a remote location.

15.5.2 Sequence of operation (Figure 15.3)

Mode	Contact
Ignition of main burner	1 & 3
High flames	1
Pilot	3
Extinguish main burner	1, 2 & 3
Ignite second burner	1 & 2
Extinguish second burner	2 & 3

Table 15.2

15.5.3 Modes of operation

Mode 1

The external source provides "ON" and "OFF" operation only. The remote control provides all other functions.

**Note:** Even if the fire is switched on by the external source, the remote control, in the thermostatic mode, controls the room temperature. The room temperature setting of the remote control will remain the same for the next ON-cycle of the external source as long as the temperature setting of the remote control has not been changed. If the remote control is in manual mode, it will go to High Fire in the next cycle of external operation.

Mode 2

The remote control must be set to the manual mode if the external source is to control the room temperature. If the handset is placed in the thermostatic mode it will override the external source.

**Note:** Frequent ON and OFF cycles will limit life expectancy of the valve and will increase battery consumption. The fireplace should be powered by the AC adapter for improved reliability and customer satisfaction.

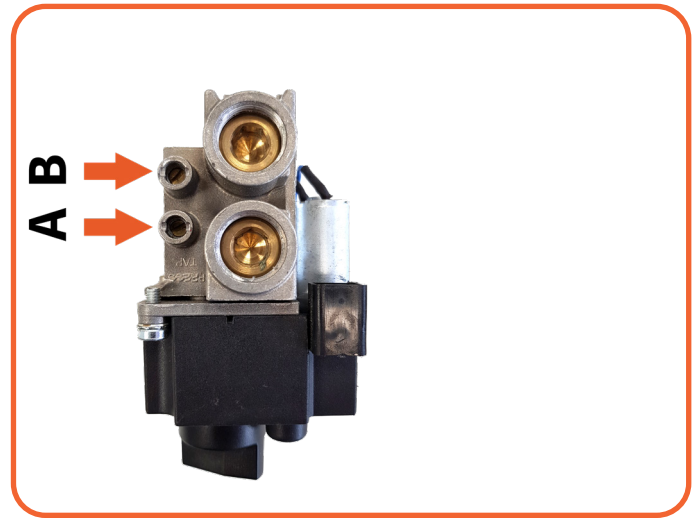

Figure 15.4 - Gas Valve Measuring Points

Schedule black 40 iron pipe

Length		Natural gas		Propane gas	
		Inside diameter			
Imperial	Metric	Imperial	Metric	Imperial	Metric
0 - 10'	0 - 3 m	1/2"	1.275 cm	3/8"	0.9525 cm
10 - 40'	3 - 12 m	1/2"	1.275 cm	1/2"	1.275 cm
40 - 100'	12 - 30 m	1/2"	1.275 cm	1/2"	1.275 cm
100 - 150'	30 - 45 m	3/4"	1.905 cm	1/2"	1.275 cm
150 - 200'	45 - 60 m	3/4"	1.905 cm	1/2"	1.275 cm

Table 15.3

**A MASSACHUSETTS CERTIFICATION**

This appliance is approved for installation in the Commonwealth of Massachusetts. The Board of State Examiners of Plumbers and Gas Fitters has issued approval number Element4 for this appliance.

**THE FOLLOWING MUST BE OBSERVED WHEN INSTALLING THE ELEMENT4 FIREPLACES WITHIN THE COMMONWEALTH OF MASSACHUSETTS:**

(a) For all side wall horizontally vented gas fueled equipment installed in every dwelling, building or structure used in whole or in part for residential purposes, including those owned or operated by the Commonwealth and where the side wall exhaust

vent termination is less than seven (7) feet above finished grade in the area of the venting, including but not limited to decks and porches, the following requirements shall be satisfied:

1. INSTALLATION OF CARBON MONOXIDE DETECTORS. At the time of installation of the side wall horizontal vented gas fueled equipment, the installing plumber or gasfitter shall observe that a hard wired carbon monoxide detector with an alarm

and battery back-up is installed on the floor level where the gas equipment is to be installed. In addition, the installing plumber or gasfitter shall observe that a battery operated or hard wired carbon monoxide detector with an alarm is installed on each additional level of the dwelling, building or structure served by the side wall horizontal vented gas fueled equipment. It shall be the responsibility of the property owner to secure the services of qualified licensed professionals for the installation of hard wired carbon monoxide detectors

a. In the event that the side wall horizontally vented gas fueled equipment is installed in a crawl space or an attic, the hard wired carbon monoxide detector with alarm and battery back-up may be installed on the next adjacent floor level.

b. In the event that the requirements of this subdivision can not be met at the time of completion of installation, the owner shall have a period of thirty (30) days to comply with the above requirements; provided, however, that during said thirty (30) day period, a battery operated carbon monoxide detector with an alarm shall be installed.

2. APPROVED CARBON MONOXIDE DETECTORS. Each carbon monoxide detector as required in accordance with the above provisions shall comply with NFPA 720 and be ANSI/UL 2034 listed and IAS certified.

3. SIGNAGE. A metal or plastic identification plate shall be permanently mounted to the exterior of the building at a minimum height of eight (8) feet above grade directly in line with the exhaust vent terminal for the horizontally vented gas fueled heating appliance or equipment. The sign shall read, in print size no less than one-half (1/2) inch in size, "GAS VENT DIRECTLY BELOW. KEEP CLEAR OF ALL OBSTRUCTIONS".

4. INSPECTION. The state or local gas inspector of the side wall horizontally vented gas fueled equipment shall not approve the installation unless, upon inspection, the inspector observes carbon monoxide detectors and signage installed in accordance

with the provisions of 248 CMR 5.08(2)(a)1 through 4.

(b) EXEMPTIONS: The following equipment is exempt from 248 CMR 5.08(2)(a)1 through 4:

1. The equipment listed in Chapter 10 entitled "Equipment Not Required To Be Vented" in the most current edition of NFPA 54 as adopted by the Board; and

2. Product Approved side wall horizontally vented gas fueled equipment installed in a room or structure separate from the dwelling, building or structure used in whole or in part for residential purposes.

(c) MANUFACTURER REQUIREMENTS - GAS EQUIPMENT VENTING SYSTEM PROVIDED. When the manufacturer of Product Approved side wall horizontally vented gas equipment provides a venting system design or venting system components with the equipment, the instructions provided by the manufacturer for installation of the equipment and the venting system shall include:

1. Detailed instructions for the installation of the venting system design or the venting system components; and

2. A complete parts list for the venting system design or venting system.

(d) MANUFACTURER REQUIREMENTS - GAS EQUIPMENT VENTING SYSTEM NOT PROVIDED. When the manufacturer of a Product Approved side wall horizontally vented gas fueled equipment does not provide the parts for venting the flue gases, but

identifies "special venting systems", the following requirements shall be satisfied by the manufacturer:

1. The referenced "special venting system" instructions shall be included with the appliance or equipment installation instructions; and

2. The "special venting systems" shall be Product Approved by the Board, and the instructions for that system shall include a parts list and detailed installation instructions.

(e) A copy of all installation instructions for all Product Approved side wall horizontally vented gas fueled equipment, all venting instructions, all parts lists for venting instructions, and/or all venting design instructions shall remain with the appliance or equipment at the completion of the installation.

**B TROUBLESHOOTING FLOWCHART**

Function		Possible cause	Remedy
<b>A</b> Press the ON button to start ignition sequence. Beep will occur each second.	<b>No</b>	Transmitter batteries low.	Replace transmitter batteries. Quality alkaline recommended.
		Receiver batteries low.	Test the batteries. replace if necessary. Quality 1.5V AA alkaline recommended. <b>Note:</b> Do NOT connect an AC adapter when using receiver batteries.
		Check that transmitter and receiver are synchronized.	Reset system, see the installation manual or the label on the receiver. One long beep indicates the wiring is incorrect or the code learning sequence has failed.
		Transmitter distance is limited.	Straighten the antenna. Replace the receiver.
		Defective AC adapter	Replace the AC adapter.
		Damaged wiring	Inspect/test all wiring and connections.
		2nd thermocouple is producing electricity.	Wait for 2nd thermocouple to cool down (3-5 minutes)
<b>Yes</b>			
<b>B</b> Magnet unit is energized thus producing an obvious latching sound.	<b>No</b> No beep	Impulse magnet not operating properly.	Replace gas valve.
	<b>No</b> 3 Short beep	Receiver batteries low.	Test the batteries, replace if necessary. Quality 1.5V AA alkaline recommended.
	<b>No</b> 1 long beep	8-wire cable is off or not operating properly.	Confirm proper operation of the 8-wire cable.
		SW-cable disconnected.	Confirm proper connection/operation of the SW-cable.
		Motor not operating properly.	Replace gas valve.
		Micro switch not operating properly.	Replace gas valve.
		2nd thermocouple not connected	Confirm integrity of 2nd thermocouple and connection.
<b>Yes</b>			
<b>C</b> Spark will occur each second.	<b>No</b>	Ignition components not operating properly.	Check connection between ignition cable and ignitor rod.
			Check ignitor rod spark gap.
			Check ignitor rod.
			Check ignition cable for damage.
	<b>No</b>	Ignition sequence stops after one spark	Increase distance between ignition cable and all metal parts.
			Remove ground bolt (T20 Torx) and clean ground lug.
<b>No</b>	Ignition sequence stops, no pilot flame. No reaction to remote control command.	Reset system, see the installation manual or the label on the receiver.	
		Do not coil the ignition cable. Shorten the ignition cable, if possible.	
<b>No</b>	Ignition sequence stops, no pilot flame. Transmitter command is possible.	Test the batteries, replace if necessary. Quality 1.5V AA alkaline recommended.	
<b>Yes (Continued)</b>			

## APPENDICES

Function		Possible cause	Remedy
<div style="border: 1px solid black; padding: 2px; display: inline-block; margin-bottom: 5px;">Yes (Continued)</div>			
<b>D</b> Pilot lit.	<b>No</b>	TC- and SW-cable reversed.	Check cable connection between receiver and interrupter block.
		Magnet unit not operating properly.	Replace gas valve.
		Short between interrupter and SW cable.	Check interrupter block connection.
		No gas (magnet unit drops after 30 second audible count.)	Check gas supply.
		Spark not lighting the pilot.	Check spark is crossing pilot orifice.
		Cracked ignitor rod (spark heard but not seen)	Ensure that ignitor rod does not move within ceramic shield. Check that ceramic shield or ignition wire is not defective.
<div style="border: 1px solid black; padding: 2px; display: inline-block; margin-bottom: 5px;">Yes</div>			
<b>E</b> Sparking stops after pilot is lit.	<b>No</b>	Short between interrupter block and TC-cable.	Check connection to interrupter block.
		Electronic measuring amplifier defective.	Replace the receiver.
<div style="border: 1px solid black; padding: 2px; display: inline-block; margin-bottom: 5px;">Yes</div>			
<b>F</b> Motor turns to main gas and pilot stays lit.	<b>No</b>	Magnet unit drop (audible sound)	Resistance in thermocouple circuit too high. Not enough heat on thermocouple.
		Low voltage from thermocouple.	Check thermocouple circuit. <ul style="list-style-type: none"> <li>Check position of pilot to thermocouple.</li> <li>Check the stability and intensity of pilot flame.</li> <li>Ensure the proper restrictor is installed.</li> <li>Ensure that the pilot flame is properly adjusted.</li> </ul> Possible cold start. Wait one minute and retry.
		No gas (magnet unit drops after 30 second audible count.)	Replace thermocouple. Do not over tighten - hand tight plus 1/4 turn maximum.
		Check gas supply.	
	<b>No</b>	Broken receiver	Ensure powered/unpowered receiver allows manual operation.
		<b>No</b>	Ignition sequence stops. No reaction to remote control command.
	“140” models ONLY: Pilot flame under hearth panel not establishing.		Remove glass and hearth panel then check for proper pilot operation. If pilot establishes with panel off then install panel and glass and adjust pilot flame (hi/lo) for best operation.
	<div style="border: 1px solid black; padding: 2px; display: inline-block; margin-bottom: 5px;">Yes</div>		

## APPENDICES

Function			Possible cause	Remedy
<b>G</b> Main burner is lit.	<b>No</b>		Manual knob is in the “MAN” position.	Turn the control knob to “ON” position, a positive latch is required.
	<b>No</b>		Pilot flame is too low.	Confirm correct gas pressure. Increase pilot flame if necessary.
<b>Yes (Continued)</b>				
<b>H</b> Main burner stays lit.	<b>No</b>	Systems drops out - all flames go out instantly	Too much draft at pilot flame (poor flame impingement of primary thermocouple.)	Check venting installation. Use restrictor as required.
			Pilot assembly out of order.	Inspect pilot assembly for correct operation and thermocouple impingement.
			5 day shut off.	The system shuts off the fire and pilot if there is no change in the flame height for 5 days.
	<b>No</b>	Main burner remains lit while flame are lowered	2nd thermocouple is not heated.	Ensure 2nd thermocouple is heated by a robust flame. The fireplace media may be interfering with proper flame. Check 2nd thermocouple wiring.
			2nd thermocouple shut off.	The system shuts off the fire when the main burner flame is not sensed within 29 seconds of ignition or not sensed after pressing the large flame button. Note: If the system fails to light due to the 2nd thermocouple voltage not being sensed a two minute lockout period begins. This lockout time allows the gas to dissipate.
	<b>No</b>	System goes to pilot flame	6 hours of no motor movement.	In Manual/Temperature/Timer modes the valve turns down to pilot only if the flame height does not change for a 6 hour period. In Temperature/Timer modes if the ambient room temperature changes, the flame height will adjust automatically to maintain the set temperature and the fire will continue to function normally. The valve will turn to pilot flame if the set temperature and the ambient temperature remain the same over a 6 hour period.
<b>Yes</b>				
<b>I</b> Magnet unit drops while motor turns. Receiver makes 3 beeps.	<b>Yes</b>		Receiver batteries low.	Test the batteries, replace if necessary. Quality 1.5V AA alkaline recommended.
			Ensure magnet unit is operating normally.	Test the receiver output to the magnet unit.
<b>No</b>				
<b>J</b> Flames become thin, blue, wispy then go out.	<b>Yes</b>		Exhaust is contaminating the fresh air.	Inspect venting for damage and/or incorrect installation.
	<b>Yes</b>		Flow of fresh air and/or exhaust is blocked.	Ensure that vent configuration is within the vent chart requirements.
				Check termination for blockage and/or appropriate type.
<b>Yes</b>		LP gas being used with NG orifice(s).	Ensure the gas type is correct for the installed orifices.	
<b>No (continued)</b>				



## APPENDICES

Function		Possible cause	Remedy
<b>No (Continued)</b>			
<b>K</b> Flames are very yellow with dark, sooty tips.	<b>Yes</b>	The air shutter is closed when using LPG.	When using LPG the air shutter must be fully open. See conversion instructions.
		Flow of fresh air and/or exhaust is blocked.	Ensure that vent configuration is within the vent chart requirements. Check termination for blockage and/or appropriate type.
<b>No</b>			
<b>L</b> Flames are very busy and blowing in an abnormal direction.	<b>Yes</b>		Check unit for leaks at glass corners or at gaskets.
			Check unit for positive relief door seal.
			Check venting for complete integrity.
<b>Yes</b>			
<b>M</b> Flames are stable but too small and blue.	<b>Yes</b>	Too much primary air.	Reduce the primary air opening until flames have blue base and yellow upper two-thirds.
<b>No</b>			
<b>Normal operation (?)</b>		If the fireplace still is not functioning normally, contact your dealer.	

## APPENDICES

### C ERRORS CODES PROCONTROL APP

#### C.1 Messages shown in app

Error code	Message in App	Description	Possible cause
<b>F02</b>	Contact Service.	<ul style="list-style-type: none"> <li>5 sec. beep from Receiver</li> <li>Fire is not responding; no ignition</li> </ul>	<ul style="list-style-type: none"> <li>Microswitch not making contact with cam on motor knob</li> <li>Motor wiring is incorrect</li> <li>Reversed polarity or faulty Microswitch</li> <li>Bent Motor Knob</li> </ul>
<b>F03</b>	Contact Service.	<ul style="list-style-type: none"> <li>5 sec. beep from Receiver</li> <li>Ignition process is interrupted</li> <li>Fire is not responding; no ignition</li> </ul>	<ul style="list-style-type: none"> <li>Thermocouple wiring is incorrect</li> <li>Thermocouple wiring is not connected</li> <li>ON / OFF switch in O (OFF) position</li> </ul>
<b>F04</b>	Ignition Sequence Malfunction. Wait 1 minute. Retry ignition.	<ul style="list-style-type: none"> <li>No pilot flame within 30 sec.</li> <li>NOTE: After 3 failed ignition sequences F06 shown</li> </ul>	<ul style="list-style-type: none"> <li>No gas supply</li> <li>Air in pilot supply line</li> <li>No spark</li> <li>Reversed polarity in thermocouple wiring</li> <li>Check for correct pilot orifice (LPG to NG or vice versa)</li> </ul>
<b>F05</b>	Contact Service.	<ul style="list-style-type: none"> <li>Pilot burner fails to ignite or shuts off</li> <li>Motor stays in pilot position</li> </ul>	<ul style="list-style-type: none"> <li>Not enough thermo-voltage</li> <li>Air in the pilot supply line</li> <li>Low inlet pressure</li> <li>Bad thermocouple</li> </ul>
<b>F06</b>	Contact Service.	<ul style="list-style-type: none"> <li>3 failed ignition sequences within 5 minutes</li> <li>Fire is not responding; no pilot flame</li> </ul>	<ul style="list-style-type: none"> <li>No gas supply</li> <li>Air in pilot supply line</li> <li>No spark</li> <li>Reversed polarity in thermocouple wiring</li> <li>Check for correct pilot orifice (LPG to NG or vice versa)</li> </ul>
<b>F07</b>	Replace Handset Batteries.	<ul style="list-style-type: none"> <li>Battery icon flashes on handset display</li> </ul>	<ul style="list-style-type: none"> <li>Low battery power in handset</li> </ul>
<b>F08</b>	Contact Service.	<ul style="list-style-type: none"> <li>Low Receiver battery power supply</li> <li>Short beeps for 3 sec. during motor turn</li> </ul>	<ul style="list-style-type: none"> <li>Low Receiver battery power supply</li> </ul>
<b>F10</b>	Contact Service.	<ul style="list-style-type: none"> <li>Pilot lit</li> <li>Main burner fails to ignite and pilot shuts off</li> <li>Ignition is blocked for 2 minutes</li> </ul>	<ul style="list-style-type: none"> <li>2nd thermocouple is out of position</li> <li>2nd thermocouple wiring is incorrect</li> <li>Gas logs out of position</li> <li>Gas ports for burner are blocked</li> </ul>
<b>F12</b>	Contact Service.	<ul style="list-style-type: none"> <li>Motor turns to pilot position</li> </ul>	<ul style="list-style-type: none"> <li>Receiver powered by batteries and Receiver temperature exceeds 60 °C</li> <li>Check air circulation and heat shield</li> </ul>
<b>F13</b>	Contact Service.	<ul style="list-style-type: none"> <li>Motor turns to pilot position</li> <li>Fan at level 4 for 10 minutes (T &gt; 80 °C)</li> </ul>	<ul style="list-style-type: none"> <li>Receiver temperature exceeds 80°C</li> <li>Check air circulation and heat shield</li> </ul>
<b>F14</b>	Contact Service.	<ul style="list-style-type: none"> <li>5 sec. beep from Receiver</li> <li>Fire is not responding; no ignition</li> </ul>	<ul style="list-style-type: none"> <li>Receiver software doesn't support a 2nd thermocouple</li> <li>Wrong Receiver</li> </ul>
<b>F15</b>	Contact Service.	<ul style="list-style-type: none"> <li>5 sec. beep from Receiver</li> <li>Fire is not responding; no ignition</li> </ul>	<ul style="list-style-type: none"> <li>2nd thermocouple wiring is incorrect</li> <li>2nd thermocouple wiring is not connected</li> </ul>
<b>F16</b>	Handset out of range.	<ul style="list-style-type: none"> <li>No temperature shown in App</li> </ul>	<ul style="list-style-type: none"> <li>Handset out of range for more than 1.5 h</li> <li>Electrical interference</li> </ul>
<b>F17</b>	Contact Service.	<ul style="list-style-type: none"> <li>Fire is not responding; no ignition</li> </ul>	<ul style="list-style-type: none"> <li>Inlet voltage exceeds 7.25 V</li> <li>Malfunction of Mains Adapter</li> </ul>
<b>F18</b>	Contact Service.	<ul style="list-style-type: none"> <li>Switch panel / touch pad not functioning</li> </ul>	<ul style="list-style-type: none"> <li>Switch panel / touch pad is locked</li> <li>Short in cable or button</li> </ul>
<b>F19</b>	Contact Service.	<ul style="list-style-type: none"> <li>Pilot drops when Motor opens main gas</li> </ul>	<ul style="list-style-type: none"> <li>Insufficient thermo-voltage</li> <li>Thermocouple malfunction</li> <li>Low inlet gas pressure</li> <li>Improper thermocouple flame impingement</li> <li>Carbon build-up on thermocouple</li> <li>Valve malfunction</li> <li>Resistance in thermocurrent circuit</li> </ul>
<b>F26</b>	Contact Service.	<ul style="list-style-type: none"> <li>It is not possible to increase flame height after ignition</li> <li>Fan at level 4 for 10 minutes (T &gt; 80 °C)</li> </ul>	<ul style="list-style-type: none"> <li>Receiver powered by batteries and Receiver temperature exceeds 60°C</li> <li>Receiver powered by mains power and Receiver temperature exceeds 80°C</li> </ul>
<b>F27</b>	Contact Service.	<ul style="list-style-type: none"> <li>Fire is not responding</li> <li>No electronic control of fire</li> </ul>	<ul style="list-style-type: none"> <li>No handset or Wi-Fi Box connected to Receiver for more than 3 hours</li> </ul>
<b>F28</b>	On-Demand Pilot	<ul style="list-style-type: none"> <li>Pilot shuts off after a predefined time</li> </ul>	<ul style="list-style-type: none"> <li>Pilot shuts off after no motor movement for a predetermined time</li> </ul>

## APPENDICES

Error code	Message in App	Description	Possible cause
<b>F31</b>	Contact Service.	<ul style="list-style-type: none"> <li>Fire is not responding</li> <li>No electronic control of fire</li> </ul>	<ul style="list-style-type: none"> <li>Receiver or Wi-Fi Box malfunction</li> <li>Connection cable from Receiver to Wi-Fi Box defective</li> </ul>
<b>F41</b>	Check Wi-Fi	<ul style="list-style-type: none"> <li>Fire is not responding</li> <li>No electronic control of fire</li> </ul>	<ul style="list-style-type: none"> <li>No Wi-Fi connection to myfire Wi-Fi Box, router and / or smart device</li> <li>Wi-Fi in smart device is deactivated</li> </ul>
<b>F42</b>	Check Wi-Fi	<ul style="list-style-type: none"> <li>Fire is not responding</li> <li>No electronic control of fire</li> </ul>	<ul style="list-style-type: none"> <li>No power to router</li> <li>No Wi-Fi connection to router and / or smart device</li> <li>Smart device not in the correct home network</li> </ul>
<b>F43</b>	No Receiver Connected. Contact Service.	<ul style="list-style-type: none"> <li>Fire is not responding</li> <li>No electronic control of fire</li> </ul>	<ul style="list-style-type: none"> <li>No communication between Receiver and myfire Wi-Fi Box</li> </ul>
<b>F44</b>	Contact Service.	<ul style="list-style-type: none"> <li>No temperature shown in App</li> <li>N.a. (not applicable) displayed in App</li> </ul>	<ul style="list-style-type: none"> <li>Handset not within range</li> <li>Low battery power in handset</li> </ul>
<b>F49</b>	Contact Service.	<ul style="list-style-type: none"> <li>No electronic control of fire</li> </ul>	<ul style="list-style-type: none"> <li>Receiver software &lt; 8.32 is not supported by myfire Wi-Fi Box Version 2</li> </ul>
<b>F50</b>	Contact Service.	<ul style="list-style-type: none"> <li>No electronic control of fire</li> </ul>	<ul style="list-style-type: none"> <li>Handset software &lt; SW 231 is not supported by the myfire Wi-Fi Box Version 2</li> </ul>

### C.2 Messages shown in remote

Error code	App Message	Time	Description	Possible Cause
<b>F04</b>	F04	4 sec.	<ul style="list-style-type: none"> <li>No pilot flame within 30 sec.</li> <li>NOTE: After 3 failed ignition sequences F06 shown</li> </ul>	<ul style="list-style-type: none"> <li>No gas supply</li> <li>Air in pilot supply line</li> <li>No spark</li> <li>Reversed polarity in thermocouple wiring</li> </ul>
<b>F06</b>	F06	4 sec.	<ul style="list-style-type: none"> <li>3 failed ignition sequences within 5 minutes</li> <li>Fire is not responding; no pilot flame</li> </ul>	<ul style="list-style-type: none"> <li>No gas supply</li> <li>Air in pilot supply line</li> <li>No spark</li> <li>Reversed polarity in thermocouple wiring</li> <li>Check for correct pilot orifice (LPG to NG or vice versa)</li> </ul>
<b>F07</b>	F07	Until batteries replaced	<ul style="list-style-type: none"> <li>Battery icon flashes on handset display</li> </ul>	<ul style="list-style-type: none"> <li>Low battery power in handset</li> </ul>
<b>F09</b>	F09	4 sec.	<ul style="list-style-type: none"> <li>Fire is not responding</li> <li>No electronic control of fire</li> </ul>	<ul style="list-style-type: none"> <li>Down arrow button was not pressed during pairing</li> <li>Receiver and handset are not synced</li> </ul>
<b>F46</b>	F46	4 sec.	<ul style="list-style-type: none"> <li>Fire is not responding</li> <li>Intermittent response</li> <li>No electronic control of fire</li> </ul>	<ul style="list-style-type: none"> <li>No or bad connection between receiver and handset</li> <li>No power at Receiver (batteries low)</li> <li>Mains adapter faulty, set not communicating with Receiver)</li> </ul>

D DIMENSIONAL DRAWINGS

On this page and the following ones you will find dimensional drawings of the Sky RD series with some of the important dimensions that you have to take into account when installing and installing your fireplace.

DWG files for design specific dimensions not listed are available for download at [www.element4fires.com](http://www.element4fires.com)

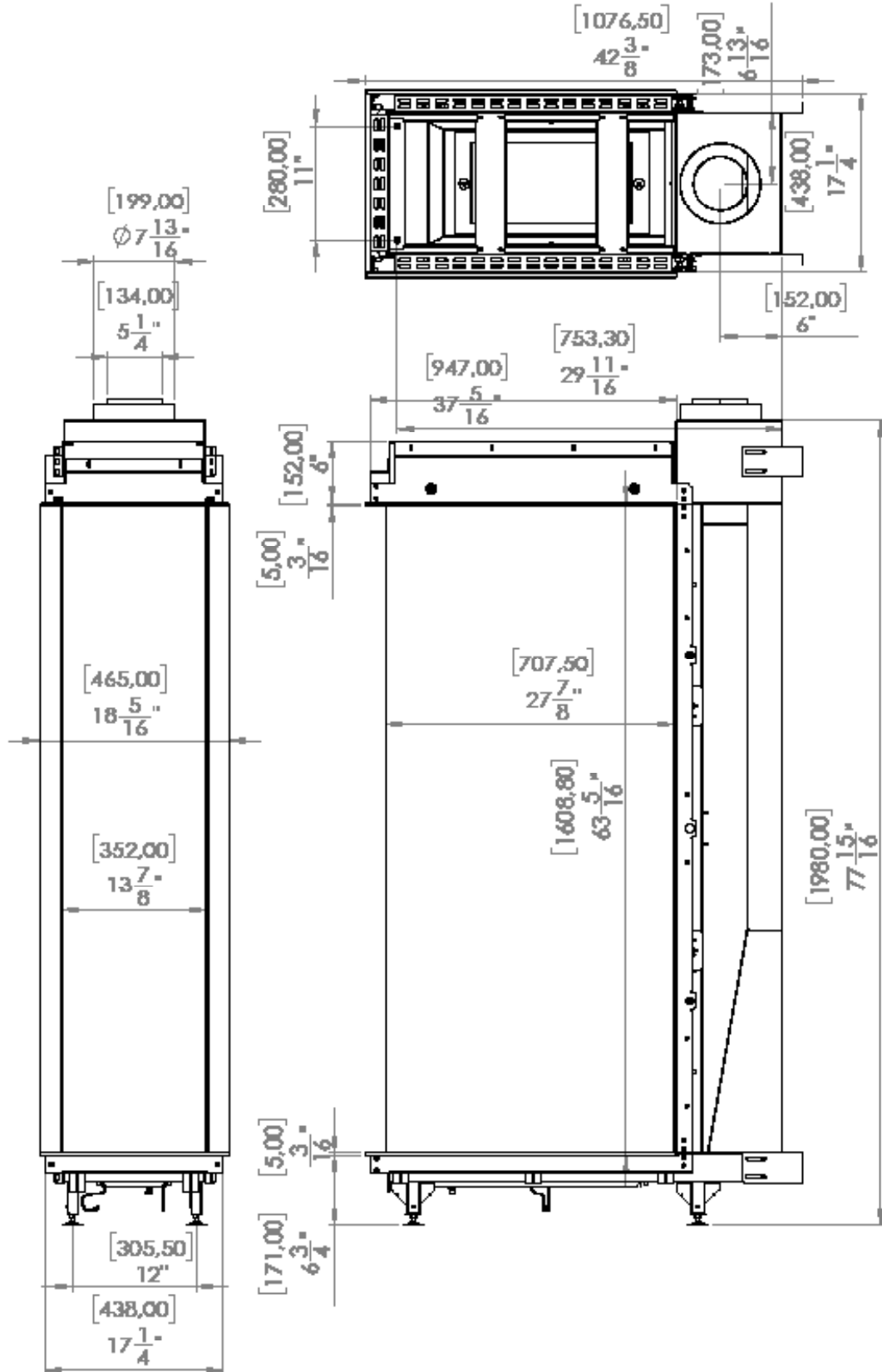

Figure D.A - Technical drawing of Sky LRD

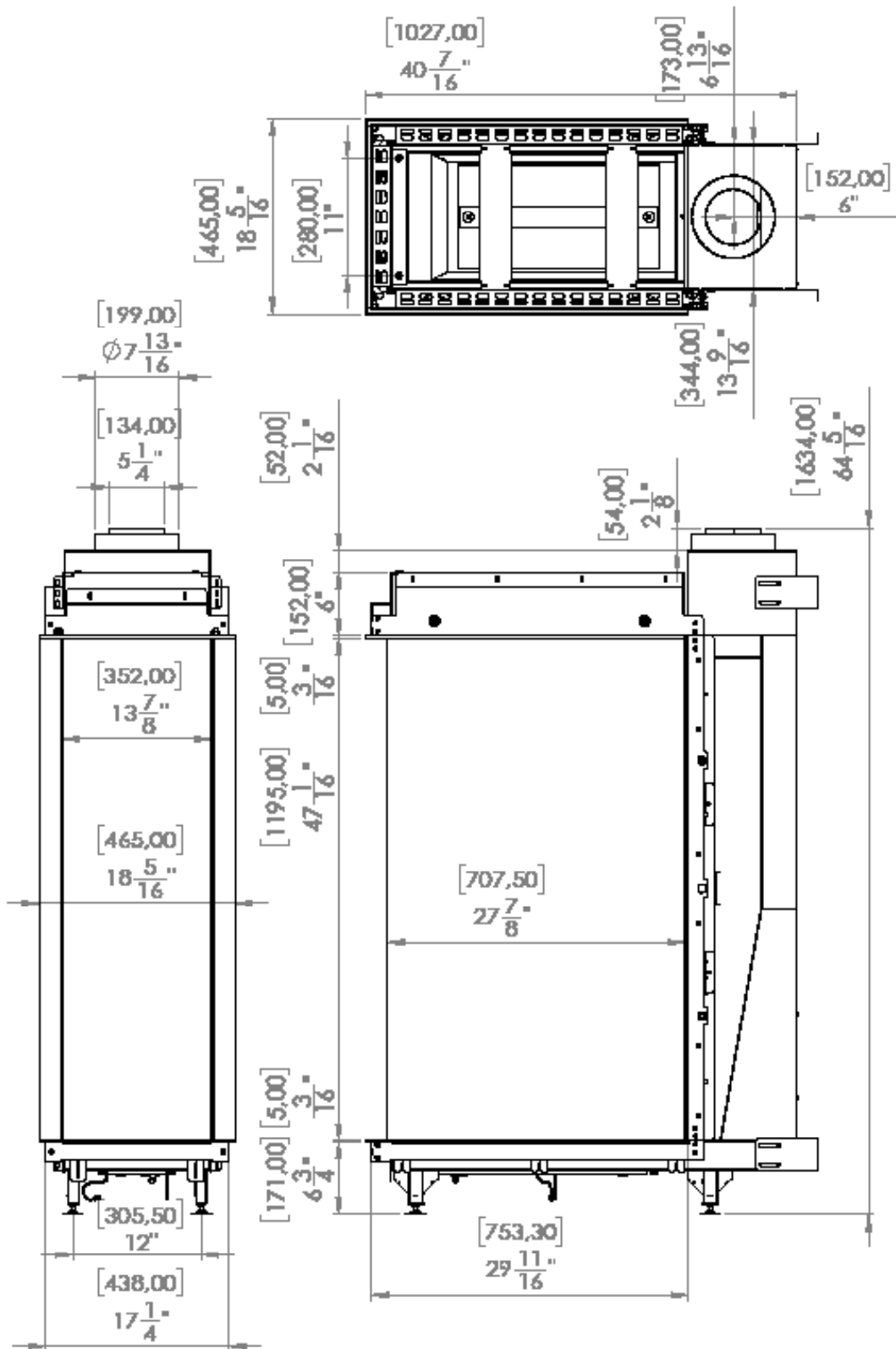

Figure D.B - Technical drawing of Sky MRD

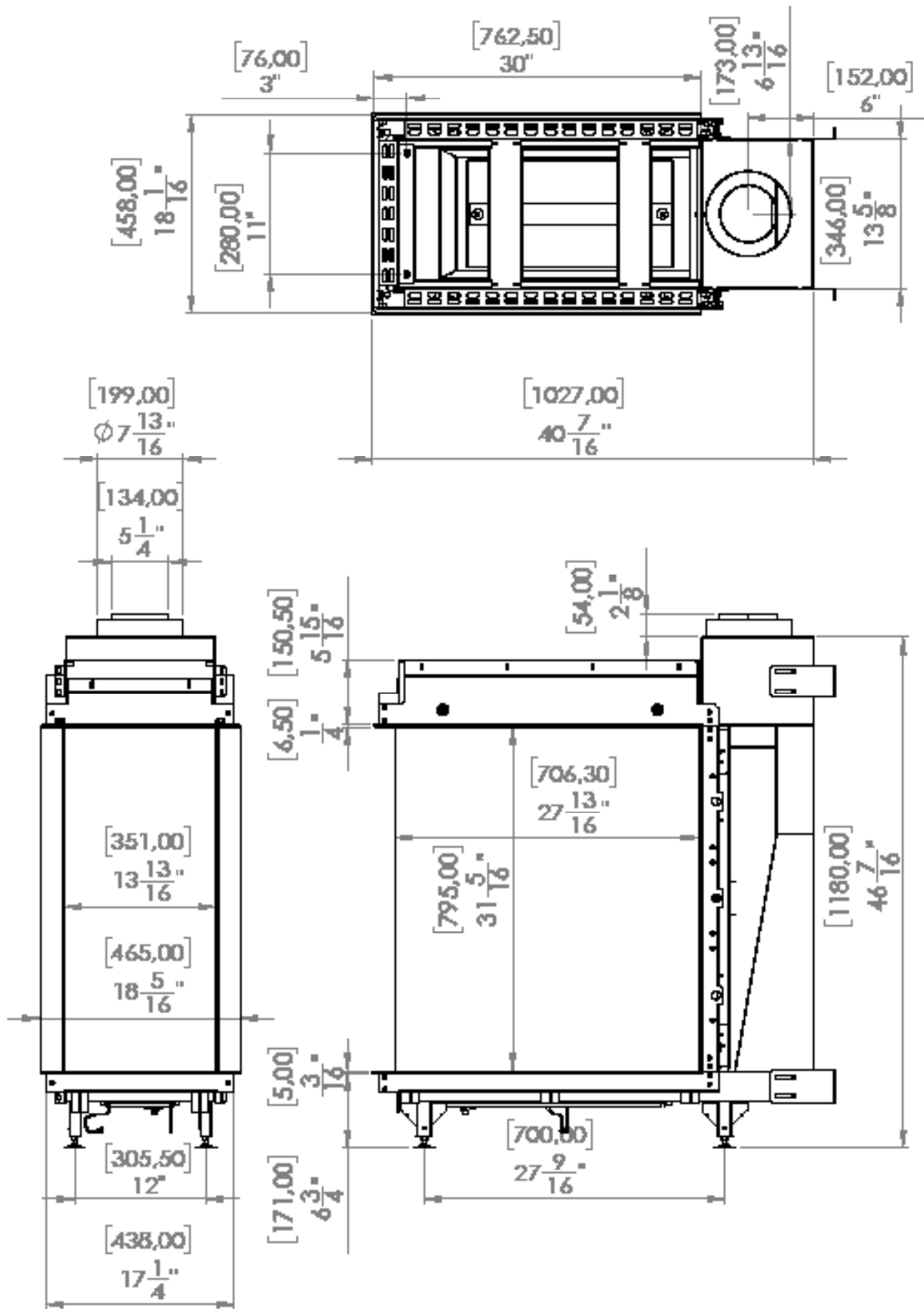

Figure D.C - Technical drawing of Sky SRD

## APPENDICES

### E SPARE PARTS

Many different parts can be distinguished for the Sky RD models. In this appendix an overview is given of several parts in the fireplace chassis, frame and accessories.

Please refer to article description in **Table D.A** in your correspondance in case a part is damaged or broken or is otherwise in need of replacement.

Part #	Description	Additional Comments
1	Firebox weldment	The main body of the fireplace.
2	Spigot 5/8 "(200/130mm)	Where the vent is attached to.
3	Relief door	Part of the safety system on overpressure in the combustion chamber. Do NOT block.
4	Window Trim (side)	Decorative trims to cover the glass clamps (6).
5	Front frame	surrounds the glass panel(s) and limits the non-combustible wall board.
6	Front window panel	The (antireflective) glass panel.
7	Side Window pane	The window pane on the short side. DO NOT remove this one
8	Fresh air duct	The duct providing the fresh air to the burner
9	Side Panel	Insert panel to cover the side of the fire.
10	Pilot assembly and cover shield	The pilot ignites the main burner (12) and is also functioning as a carbon monoxide safety mechanism for when fire is suffocating.
11	Log Burner (2x)	Rectangular metal burner over which decorative media is placed for realistic fire effect.
12	Second thermocouple and cover	Safety mechanism for the fireplace that senses whether burner is active.
13	Flat burner	Main burner in the bottom of the fire, that ignites log burners (11).
14	Burner grate	Admits air and is covered in decorative media.
15	Bottom trim	Decorative trim to cover the bottom opening in the frame.
16	Adjustable feet	Gives the installer the ability to level the fireplace.

*Table E.A*

# APPENDICES

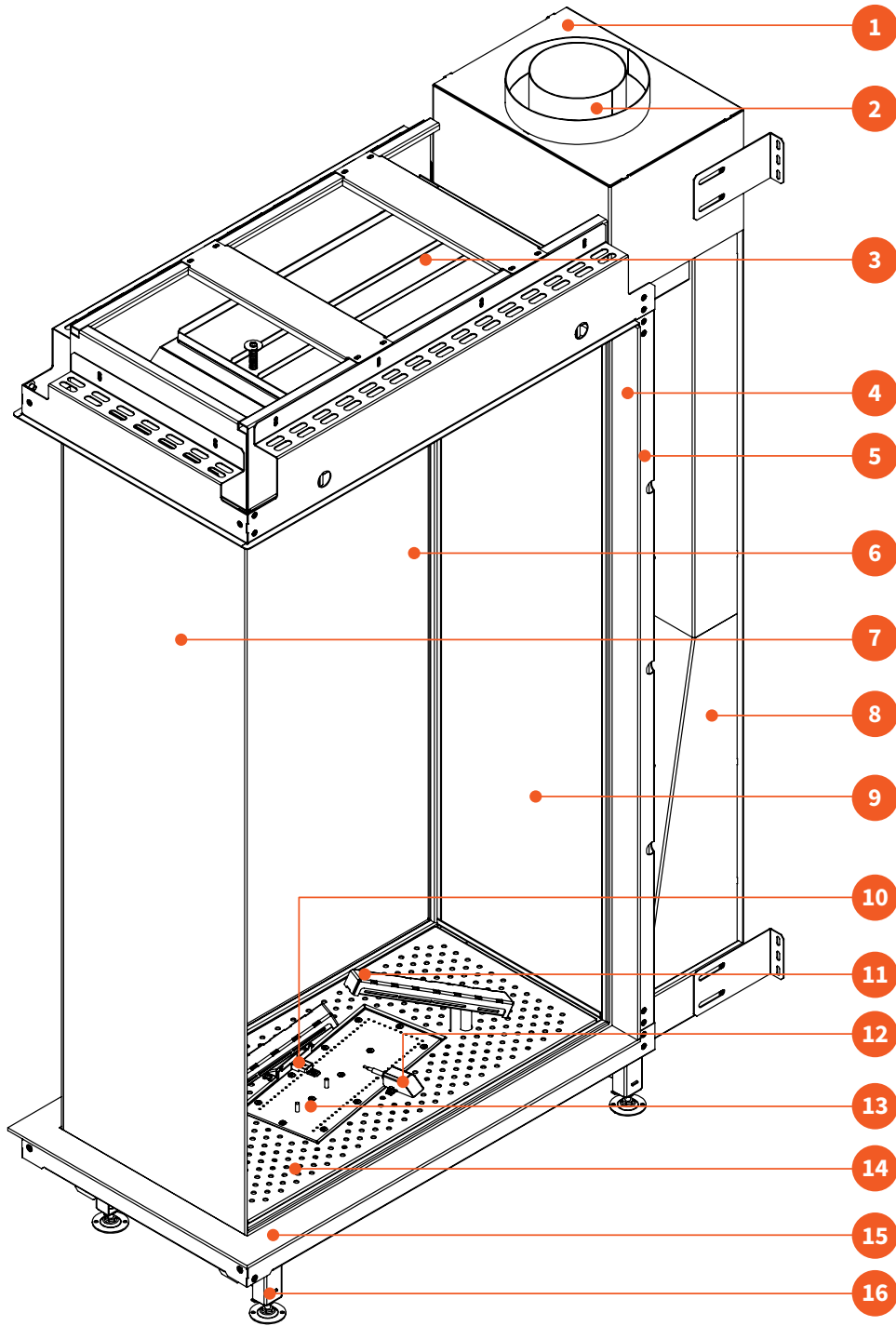

Figure E.A - Sky Spare parts

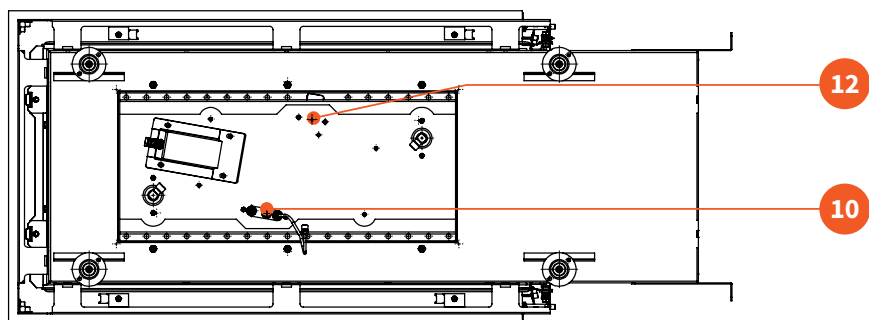

Figure E.B - Sky Spare parts 2



**F ELEMENT4 WARRANTY**

Element4 Gas Fireplace

Element4 warrants these gas fireplaces against defects in materials and workmanship for a period of TWO (2) YEARS from the date of original retail purchase. Glass is expressly NOT covered by this warranty.

If a defect exists, Element4 will, at its option, either (1) provide needed components using new or refurbished replacement parts or (2) exchange the product with one which is new or which has been manufactured from new or serviceable used parts and is at least functionally equivalent to the original product. A replacement product/part assumes the remaining warranty of the original product or ninety (90) days from the date of replacement or repair, whichever provides longer coverage for you.

When a product or part is exchanged, any replacement item becomes your property and the replaced item becomes the property of Element4. All warranty claims must be submitted through the dealer from which you purchased the product. Check with your dealer in advance for any costs to you when arranging a warranty call. Shipping and/or delivery charges for parts are not covered by this warranty.

Nothing in the above shall be deemed to imply that this warranty shall apply to work which has been abused or neglected or shows evidence of changes or modifications by others with or without permit, damages caused by the acts of God, building settlement or moving, fire or vandalism. In addition, installation of this product that varies from the requirements stated in the instruction manual will void the warranty.

**PRODUCT INSTALLATION RECORD**

**Installer:** Please complete this form.

**Customer:** Please retain this information.

<b>Model (Check one)</b>	<input type="checkbox"/> Sky LRD	<input type="checkbox"/> Sky MRD	<input type="checkbox"/> Sky SRD
<b>Purchased from</b>			
<b>Installed by</b>			
<b>Date of installation</b>			
<b>Fireplace serial number</b>			
<b>Fuel Type</b>	<input type="checkbox"/> Naturel Gas		
	<input type="checkbox"/> LPG		
<b>Total horizontal section (venting)</b>			
<b>Total vertical section (venting)</b>			





Manufactured by:

**ELEMENT 4 B.V.**

Simon Stevinweg 6A  
8013 NB Zwolle  
The Netherlands  
Info@element4.nl  
www.element4.nl/en

---

**RELEASE DATE | 04/01/24**

