

## SPECIFICATIONS

<b>Model No.</b>	938401 (HPV) or 938402 (VPV)
<b>Power Requirement</b>	110/120V mains power supplied by Appliance
<b>Installation Compliance</b>	ANSI Z223.1/NFPA 54 CSA B149.1
<b>Vent System</b>	Power direct-vent with 4" x 6 5/8" vent pipe
<b>Vent Termination Locations</b>	Roof or Wall mounted Terminations
<b>Minimum Vent Length</b>	24"
<b>Maximum Vent Length</b>	50' (600")
<b>Vent Clearances to Combustibles</b>	3" above vent, 1" to sides/below vent

<b>Bends Allowed</b>	6 @ 90° and 12 @45°
<b>Max. Vent drop below Fireplace</b>	60"
<b>Max. Flue Path Vent Pipe Drop</b>	144"
<b>Vent Pipe Support</b>	Horizontal Run - 1x support bracket every 3' Vertical run - 1x support bracket every 4'

This information sheet is intended as a guide only. It does not replace any, or substitute for, the requirements of any local, state or federal building codes and regulations. It is the responsibility of the fireplace specifier, installer, or owner to ensure compliance with any local, state or federal building codes and regulations.

## HORIZONTAL POWER VENT INSTALLATION

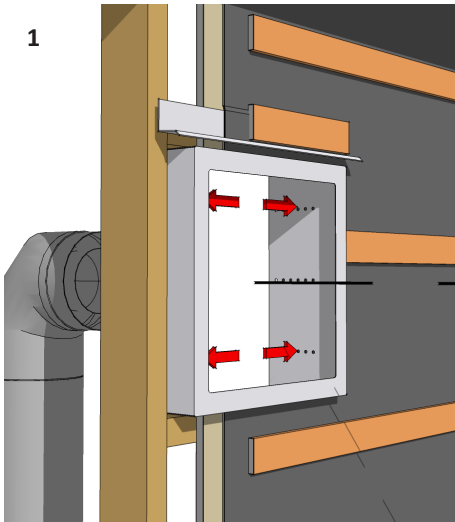

1 Establish the vent pipe centerline for the Horizontal Power Vent terminal, ensuring external clearances are met. Construct a 14 1/2" framework inside the wall, following minimum combustible clearance guidelines. Install the wall thimble into the wall to align with the siding.

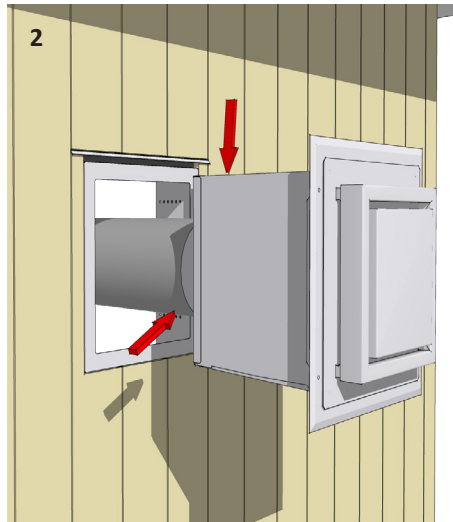

2 Attach the 4" x 6 5/8" vent pipe to the Vertical Power Vent Terminal. Connect the supplied power cable to the fireplace, with all wiring performed by a qualified electrician. Complete the wall siding installation, ensuring weathertightness in accordance with local building codes.

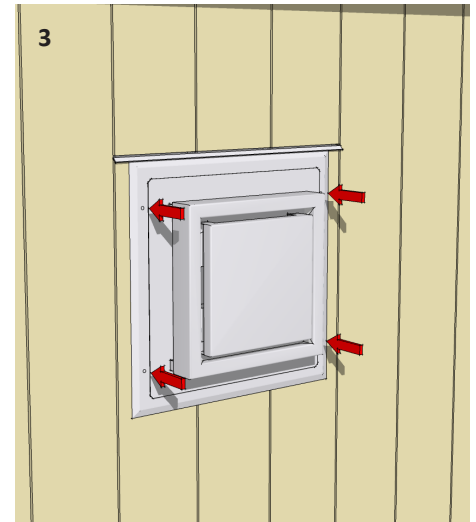

3 Install the Horizontal Power Vent Terminal onto the wall thimble, securely sealing and screwing it into place.

## VERTICAL POWER VENT INSTALLATION

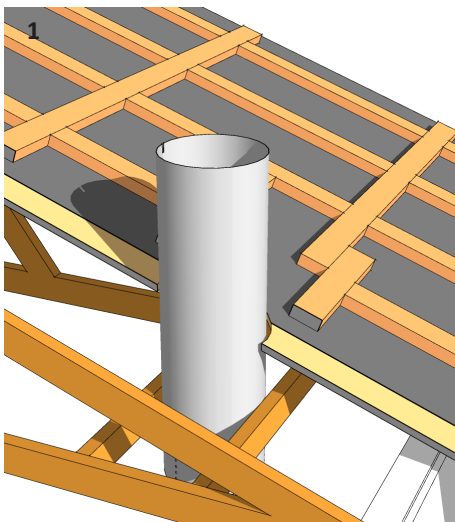

1 Locate and clear the vent pipe centerline. Create a 12" roof hole for the 11" vent liner, ensuring proper combustible material clearances and heights are met, as required.

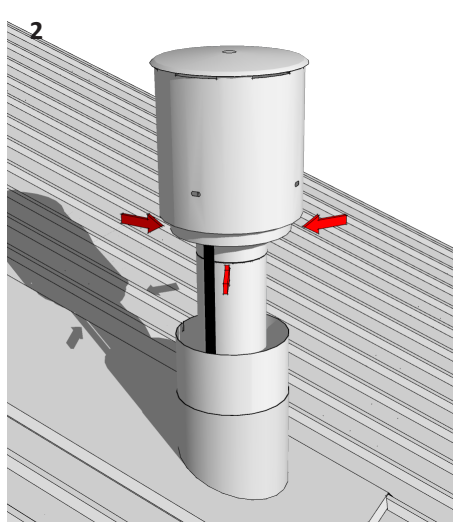

2 Install roof penetration flashing per local regulations. Attach 4" x 6 5/8" vent pipe to Power Vent Terminal. Connect Power Cable to fireplace, ensuring wiring by qualified electrician.

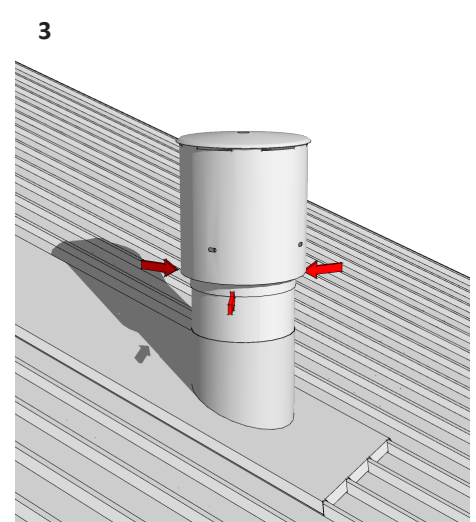

3 Fit the Vertical Power Vent Terminal onto the 11" Vent Liner and, seal and secure in place.

# Escea KS Series Vertical Vent Information Sheet

Information Sheet for Builders and Architects

## HORIZONTAL POWER VENT DIMENSIONS

Horizontal Power Vent Outer Height and Width (A)	15"
Exhaust Port Height and Width (B)	10 1/8"
Exhaust Port Depth off Wall (C)	2 7/32"
Horizontal Power Vent Fan Unit (D)	12 1/8"
4" x 6 3/8" Vent Pipe Adapter (E)	3 7/8"
Wall Thimble Depth (F)	6 1/32"
Wall Thimble Height and Width (G)	14 3/32"

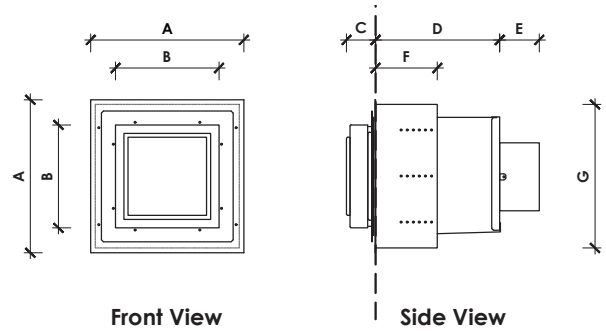

## VERTICAL POWER VENT DIMENSIONS

Terminal Outer Diameter	13 15/16"
Terminal Height (B)	14 17/32"
Terminal Inner Diameter (C)	13 1/8"
Vent Pipe Adapter Height (D)	1 1/2"
Vent Pipe Adapter Diameter (E)	11 7/32"

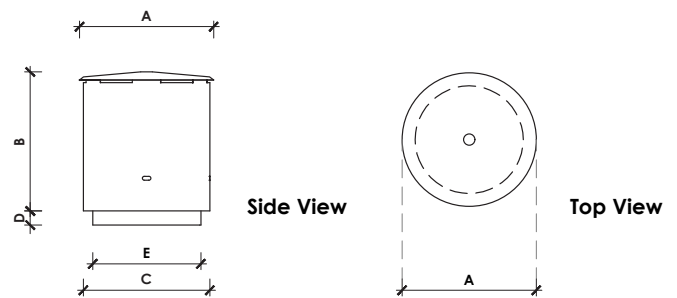

## VENT TERMINATION

The Vertical or Horizontal Power Vent Terminal includes an intake and exhaust port with a vent fan that actively removes combustion gas, creating negative pressure in the vent pipe. This termination must stay accessible for fireplace servicing throughout its lifespan. Confirm that clearances from building openings align with the manufacturer's instructions, by referring to the Fireplace Installation Manual for specifics on vent termination clearances.

## VENT LINER

Mount the Vertical Power Vent Terminal on the supplied 11" Dia. 24 gauge, 36" long Aluminum liner. The liner is to be secured to the roof's structural framework and extend at least 12" above the roof surface from its highest penetration point.

## JOINTS AND CONNECTIONS

Seal the Vertical Power Vent liner to the Vertical Power Vent Terminal, ensuring a weather-tight connection to the roof per local Building Regulations. Utilize sealant rated for 300°F continuous exposure. No requirement to seal each joint of the 4" x 6 5/8" vent pipe.

## VENT PATHWAY

Escea Gas Fireplaces use a Powered Direct Vent system with a fan-controlled vent terminal and co-axial 4" x 6 5/8" vent pipe. This vent path can run vertically, horizontally, or a combination of both, through various building elements such as a chase, walls, floors, roofs, to the side or below the fireplace.

Adhere to safety guidelines, vent specifications, and installation instructions in the Fireplace Installation Manual and local Building Regulations.

Note: a Carbon Monoxide detector is not necessary for room-sealed fireplaces.

## VENT SYSTEM IN A CHASE

A chase is a vertical box-like structure, enclosing the fireplace and vent system. Ensure the chase accommodates minimum vent pipe clearances from combustibles. In colder regions, insulate the chase as per standard home insulation practices. Construct wooden framework in compliance with local, state, or federal building codes. If two vertical terminations share a chase and are placed closely, keep them at least 12" apart and at the same height.

## VENT FIRE-STOPS

Fire-stops enhance safety for vent systems, where the vent system passes through an interior wall, an exterior wall, or a ceiling. For horizontal runs through walls, use wall fire-stops on both sides. For vertical runs through roofs or floors, use a ceiling fire-stop above. If it's an attic, secure it above the framed hole.

## VENT PIPE SUPPORT

**Horizontal Pipe Support:** Install non-combustible support every 36" with 1" clearance from sides/base, and 3" from the top to combustibles.

**Vertical Pipe Support:** Use non-combustible wall brackets every 48", securing them to structural framing with 1" clearance from vent pipe sides.

## Determine the effective vent length by completing the fields below:

(Note: the fireplace height is always included in the calculation)

Fireplace Height	=	42"
Total Vertical Run Upwards	=	
Total Vertical Run Downwards	=	
Total Horizontal Run	=	
Max. Number of 90° Bends (multiply No. By 3)	=	
Max. Number of 45° Bends (multiply No. By 1.5)	=	
<b>Total Effective Length</b>	=	