



Models
OLF46-AM
OLF66-AM
OLF86-AM

Installation and User's Guide



We value your feedback!

Your input helps to create even better products and experiences.

Share the warmth and leave a review.

dimplex.com/sharethewarmth

 [YouTube/Dimplex](https://www.youtube.com/Dimplex) 

IMPORTANT SAFETY INFORMATION:

Read this manual first before attempting to install or use this electric fireplace. Always comply with the warnings and safety instructions contained in this manual to prevent personal injury or property damage.

To view the full line of Dimplex products, visit www.dimplex.com



Table of Contents

Welcome	3
⚠ IMPORTANT INSTRUCTIONS	4
Technical Specifications	6
Electrical Rating	6
Product Dimensions	6
Package Contents	7
Installation	9
Placement	9
Preparing the Firebox for Installation	10
Fresh Air Inlets	10
Framing	11
Installation Instructions	12
Water Supply Connection	13
Electrical Installation	14
Heater Hardware Disconnect	16
Flame Baffles	17
Media Arrangement	17
Front Glass Installation	18
Operation	19
General Operation	19
Resetting the Temperature Cutoff Switch	21
Factory Reset	22
Priming the Unit	22
Maintenance	23
Remote Control Battery Replacement	23
Cleaning	23
Transducer Replacement	23
Servicing	23
Troubleshooting	24
Wiring Diagrams	26
Warranty	28

Welcome

Thank you and congratulations for choosing to purchase a Dimplex fireplace.

Please carefully read and save these instructions.

⚠ WARNING: Read all instructions and warnings carefully before starting installation. Failure to follow these instructions may result in a possible electric shock, fire hazard and will void the warranty.

Please record your model and serial numbers for future reference. Model and serial numbers can be found on the label located at the top right corner inside the fireplace.

Model _____ MOD _____
Serial Number _____

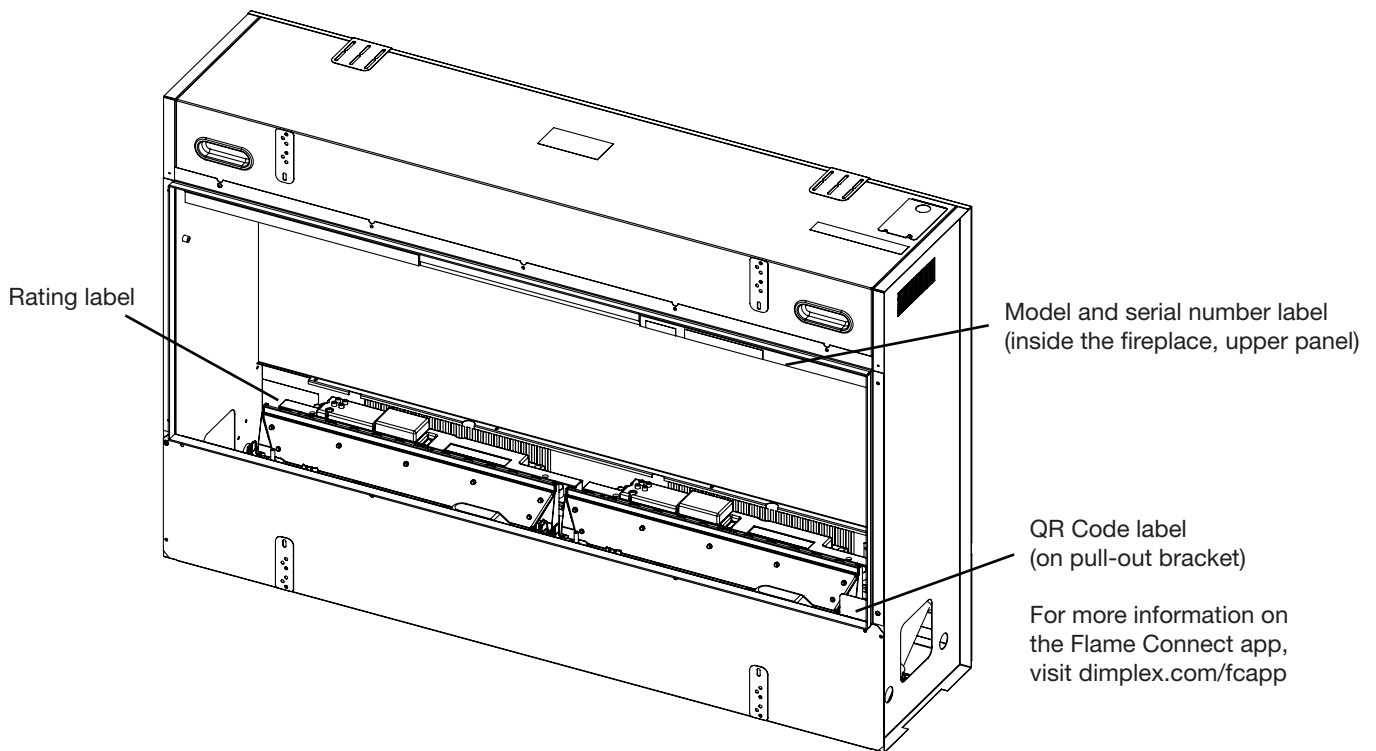

STOP NO NEED TO RETURN TO THE STORE

If you have questions regarding the operation of this product or if you require service, before returning this product to the place of purchase,

Contact us at:  www.dimplex.com/support

For Troubleshooting and Technical Support

OR  **Toll-Free 1-888-346-7539**

Please have your model number and product serial number ready.

IMPORTANT INSTRUCTIONS

When using any electrical appliance, basic precautions should always be followed to reduce the risk of fire, electric shock, and injury to persons. These precautions include:

- ① Read all instructions before using this electric fireplace.
- ② This fireplace is hot when in use. To avoid burns, do not let bare skin touch hot surfaces. The trim around the heater outlet becomes hot during heater operation.
-  **DANGER:** High temperatures may be generated under certain abnormal conditions. Do not partially or fully cover or obstruct the front of the fireplace.
- ③ Extreme caution is necessary when the fireplace is used by or near children or people with disabilities and whenever the fireplace is left operating and unattended.
- ④ Always turn off the fireplace when it is not in use.
- ⑤ Do not operate the fireplace after it malfunctions, has been dropped, or damaged in any manner. Disconnect power at the service panel and have the fireplace inspected by a reputable electrician before using.
- ⑥ Do not operate any unit with a damaged cord or if the heater has malfunctioned, or if the heater has been dropped or damaged in any manner, contact Glen Dimplex Americas Technical Service at 1-888-346-7539.
- ⑦ Do not use this fireplace outdoors.
- ⑧ Never locate the fireplace where it may fall into a bathtub or other water container.

- ⑨ To disconnect the heater, turn the unit off with the controls and turn off the power to the heater circuit at the main disconnect panel.
- ⑩ Do not insert or allow foreign objects to enter any ventilation or exhaust opening as this may cause an electric shock, fire, or damage to the fireplace.
- ⑪ To prevent a possible fire, do not block air intakes or exhaust in any manner.
- ⑫ All electrical heaters have hot and arcing or sparking parts inside. Do not use it in areas where gasoline, paint, or flammable liquids are used or stored.
- ⑬ Do not modify this fireplace. Use it only as described in this manual. Any other use may cause fire, electric shock, or injury to persons.
- ⑭ Always use a certified electrician should new circuits or outlets be required.
- ⑮ Always use properly grounded, fused and polarized outlets.
- ⑯ Disconnect all power coming to the fireplace at the main service panel before performing any cleaning, maintenance, or relocation of the unit.
- ⑰ When transporting or storing the fireplace, keep it in a dry place, free from excessive vibration, and store to avoid damage.
- ⑱ Regular cleaning and maintenance is required to ensure safe and correct operation.

! NOTE: Changes or modifications not expressly approved by the party responsible for compliance could void user's authority to operate the equipment.

SAVE THESE INSTRUCTIONS



CAUTION
RISK OF ELECTRIC SHOCK
DO NOT OPEN
NO USER-SERVICEABLE PARTS INSIDE



IMPORTANT INSTRUCTIONS

FCC Compliance

 **CAUTION:** This unit has been tested and found to comply with the limits for Class B digital device, pursuant to part 15 of the FCC Rules. These limits are designed to provide reasonable protection against harmful interference in a residential installation. This unit generates, uses and can radiate radio frequency energy and, if not installed and used in accordance with the instructions, may cause harmful interference to radio or television reception, which can be determined by turning the unit OFF and ON, the user is encouraged to try to correct the interference by one or more of the following measures:

Reorient or relocate the receiving antenna.

Increase the separation between the unit and the receiver.

Connect the unit into an outlet on a circuit different from that to which the receiver is connected.

Consult the dealer or an experienced radio/TV technician for help.

This unit complies with Part 15 of the FCC Rules. Operation is subject to the following two conditions: (1) This unit may not cause harmful interference, and (2) this unit must accept any interference received, including interference that may cause undesired operation.

 **FCC CAUTION:** Any changes or modifications not expressly approved by the party responsible for compliance could void the user's authority to operate this equipment.

 **WARNING:** This product can expose you to chemicals including nickel which is known to the State of California to cause cancer. For more information, visit www.P65Warnings.ca.gov

Conventions used in this manual:

 **NOTE:** Procedures and techniques that are considered important enough to emphasize.

 **CAUTION:** Procedures and techniques which, if not carefully followed, will result in damage to the equipment.

 **WARNING:** Procedures and techniques which, if not carefully followed, will expose the user to the risk of fire, serious injury, or death.

Technical Specifications

Electrical Rating

Voltage: 120 V (3-Wire) or 240 V (4-Wire)

Power:

Model	120 V	240 V	No heat (120 V)
OLF46-AM	1220 W	1920 W	520 W
OLF66-AM	1480 W	2180 W	760 W
OLF86-AM	1020 W (see note)	2400 W	1020 W

! NOTE: For OLF86-AM, when connected to 120 V, there will be no heat output, but heat functions will be active on the controls with only fans operating.

UL Listing

File Number: E71416



Model Reference	
OLF46-AM	6911540100
OLF66-AM	6911540200
OLF86-AM	6911540300



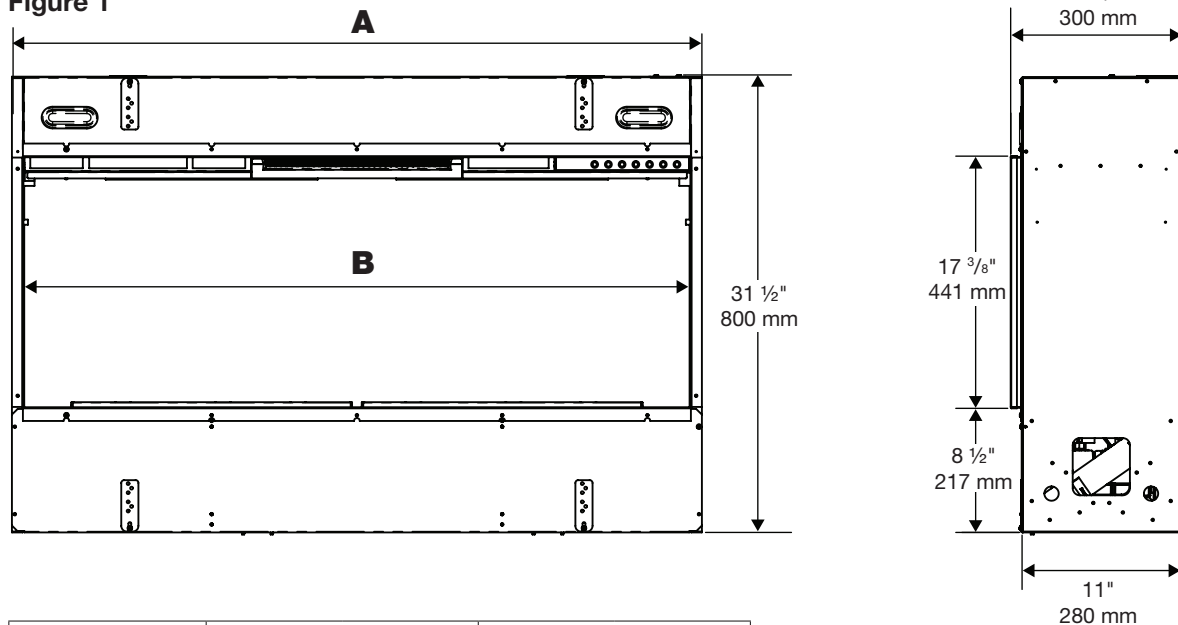

Product Dimensions

Figure 1



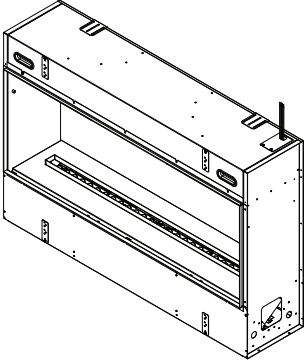
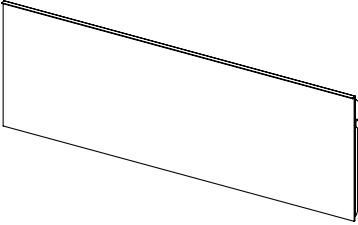

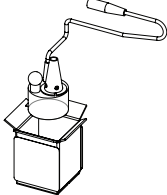
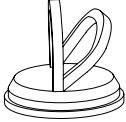

Model	A		B	
OLF46-AM	47 1/2"	1206 mm	46 1/8"	1170 mm
OLF66-AM	67 1/2"	1714 mm	66 1/8"	1678 mm
OLF86-AM	87 1/2"	2222 mm	86 1/8"	2186 mm

Package Contents

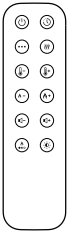
Image	Description	Quantity		
		OLF46-AM	OLF66-AM	OLF86-AM
	Firebox	1	1	1
	Front Glass	1	1	1
	Bag of Small Acrylic Crystals	2	3	4
	Bag of Large Acrylic Crystals	1	1	2
	Bag of Extra-Large Acrylic Crystals	1	1	1
	Driftwood	8	12	15
	Spare Transducer <i>Keep it in a secure location for future use.</i>	2	3	4
	Suction Cup <i>Do not dispose of the suction cup after installation. Keep it in a secure location as it will be helpful for maintenance and service of the unit.</i>	2	2	2

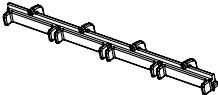
Package Contents

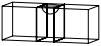
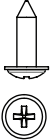
	<p>Remote Control <i>Includes two 3 V batteries</i></p>	1	1	1
	<p>User's and Installation Guide</p>	1	1	1
	<p>Breakable Flame Baffles</p>	4	6	8
	<p>Slotted Flame Baffles</p>	6	9	12
	<p>Bubble Level</p>	1	1	1
	<p>1 1/2" Wood Screws</p>	4	4	4

*Package contents are subject to change

Optional Accessories

Description	Model Number		
	OLF46-AM	OLF66-AM	OLF88-AM
Quantity	2	3	4
Air Intake Grille <i>Accessory Air Intake Grille for fresh air inlets.</i>	X-00275	X-00275	X-00275

*Please contact your local Dimplex dealer for inquiries.

Installation

Placement

! **NOTE:** For optimized viewing angle of the flame, it is recommended that the bottom of the unit be mounted between 5" (13 cm) and 50" (127 cm) from the ground. (Figure 2)

Installation in a Bathroom

If this unit is installed in a bathroom, it must be protected by a GFCI receptacle or circuit. If a receptacle is used, it must be readily accessible.

This electrical appliance is NOT watertight. To prevent electric shock, it must be installed as to prevent water from entering unit, or installed away from showers, tubs, etc. Never locate fireplace where it may fall into a bathtub or other water container.

Installation Recommendations for Overhanging Objects

For overhanging temperature-sensitive objects, such as a television, a mantel, or artwork, always follow the recommendations provided by its manufacturer for installation over a heater.

Figure 2

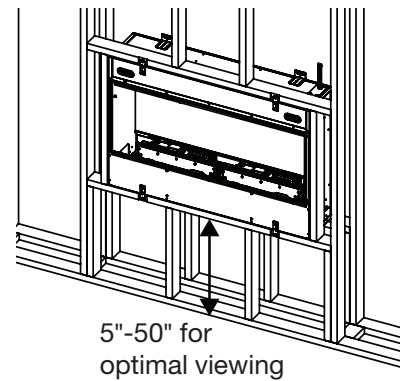

Installation

Fresh Air Inlets

⚠ CAUTION: Failure to include a fresh air inlet will result in poor flame performance and damage to the fireplace.

A fresh air inlet is required. The air inlet must allow for the air path to reach the underside of the unit. This will have to be accounted for in the framing and drywall installation. See the table below for air inlet requirements for each model. See **Figure 3** for examples on incorporating fresh air inlets in the installation.

If the air inlet is concealed using a grille, the covered area must be compensated for by having a larger opening.

Model	Air inlet area required	
OLF46-AM	80 in ²	516 cm ²
OLF66-AM	120 in ²	774 cm ²
OLF86-AM	160 in ²	1032 cm ²

Figure 3

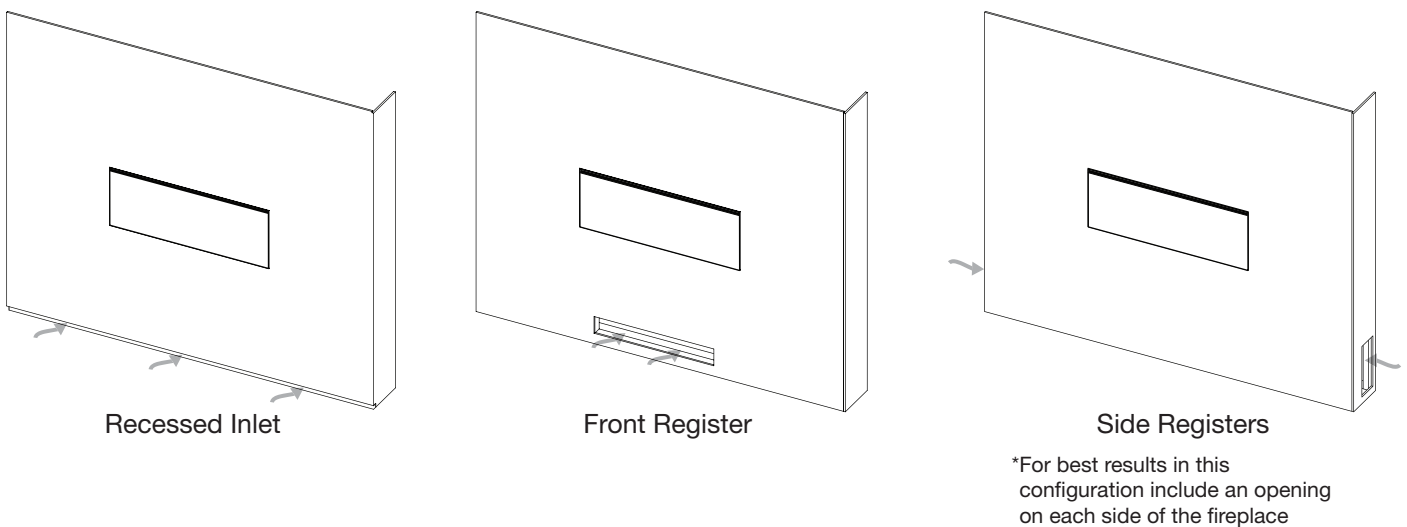

Preparing the Firebox for Installation

1. The unit is provided with mounting brackets attached (**Figure 4**). Remove the mounting brackets before installation. They will need to be reinstalled during installation once the firebox is placed into the framing.
2. If using the plug accessory kit (OLFPLUG, sold separately), wire it following the instructions for the plug kit in the *Electrical Installation* section (page 14).
3. For permanent heat disable only: follow the instructions for disconnecting the heat function in the section *Heater Hardware Disconnect* (page 16).

Figure 4

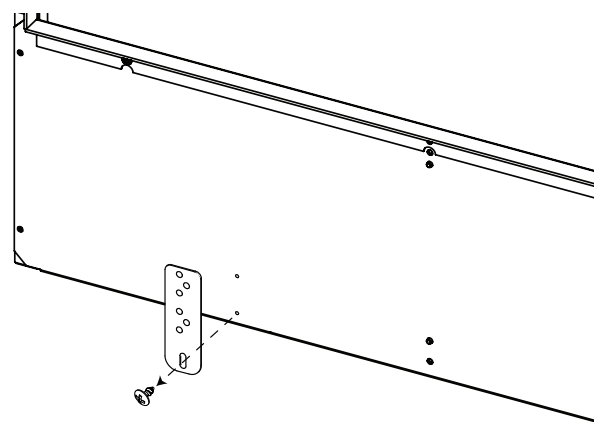

Installation

Framing

1. Prepare a wall with a framed opening, following the dimensions in the table below. Openings beneath the unit are required in order to allow for airflow to reach the underside of the unit. (Figure 6)

Model	Framing Dimensions			Drywall Opening	
	Width (minimum) A	Height B	Depth (minimum) C	Width D*	Height E*
OLF46-AM	48" 1219 mm	32 1/2" 826 mm	12" 305 mm	46 3/16" 1174 mm	17 1/2" 445 mm
OLF66-AM	68" 1727 mm			66 3/16" 1682 mm	
OLF86-AM	88" 2235 mm			86 3/16" 2190 mm	

* Allows for a 2 mm clearance all around

⚠ CAUTION: This fireplace is NOT load-bearing. Ensure the opening for the fireplace is framed in such a way that the weight of the building materials will not create pressure on the top of the fireplace.

! NOTE: Field wiring is located at the top right back corner of the firebox. The connection to water supply is located at the bottom left back corner of the firebox. Plan the framing to allow routing the electrical power cable and the cold-water line to this location.

! NOTE: Ensure the unit is level and flush with the framing.

Figure 5

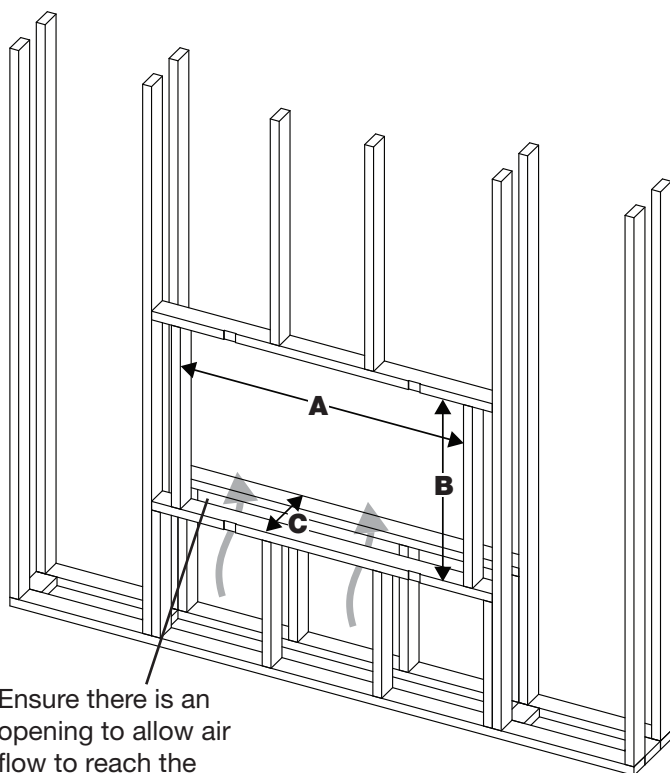

Ensure there is an opening to allow air flow to reach the underside of the unit

Figure 6

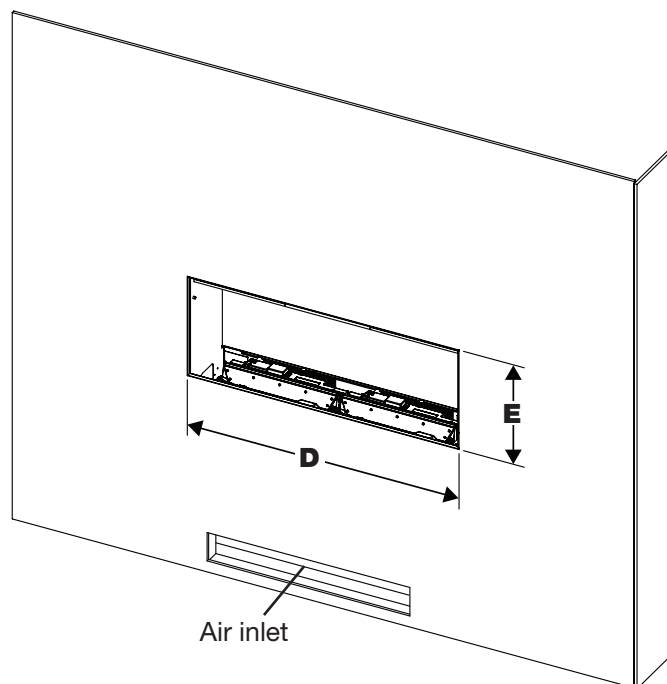

Installation Instructions

! **NOTE:** Two people are recommended for installation.

1. Follow the instructions in the section *Preparing the Firebox for Installation* (page 10) before beginning.
2. Prepare a wall with a framed opening, following the dimensions in the *Framing* section (page 11).

⚠ **CAUTION:** Ensure there is an air inlet with a path for air flow to reach the underside of the unit.

3. Place the firebox into the framed opening. Ensure the unit is level. A bubble level is included in the hardware kit provided.
4. Secure the firebox to the frame using the previously removed mounting brackets. The unit must be secured to the frame with the mounting brackets.

! **NOTE:** To avoid bulging of the finished surface, notch the framing to allow the mounting brackets to be flush with the framing. (Figure 7)

5. Connect the unit to the water supply, following the instructions in the section *Water Supply Connection* (page 13).
6. Locate the connector plate in the top right back corner of the unit. Remove the connector plate by removing the 2 securing screws. (Figure 8)
7. Install a cable connector (not included), suitable for installing in a $\frac{7}{8}$ " (22 mm) hole, to the plate and feed the supply cable through the cable connector.
8. Complete the wiring according to instructions in the *Electrical Installation* section (pages 14–15). Reinstall the connector plate after completing wiring.
9. Finish surrounding wall up to the trim if a permanent installation is desired. A removable trim can be used instead to cover the framing opening to allow the fireplace to be removed without damaging the finished wall.

⚠ **CAUTION:** Ensure air inlets are present in final installation (see *Fresh Air Inlets*, page 10).

! **NOTE:** It is recommended that all drywall installation and finishing be completed after unit is fully installed, inspected, and operational.

10. Finish the installation using the finishing materials of your choice.
11. Place the media as desired and install the front glass.
12. Press the standby button on the remote to initialize the remote.

Figure 7

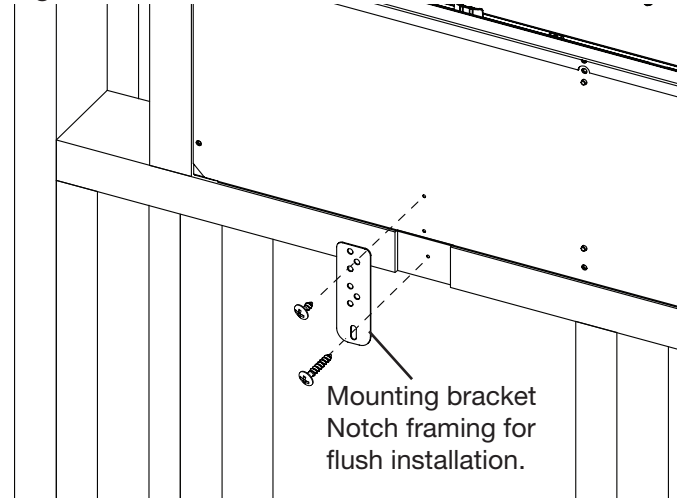
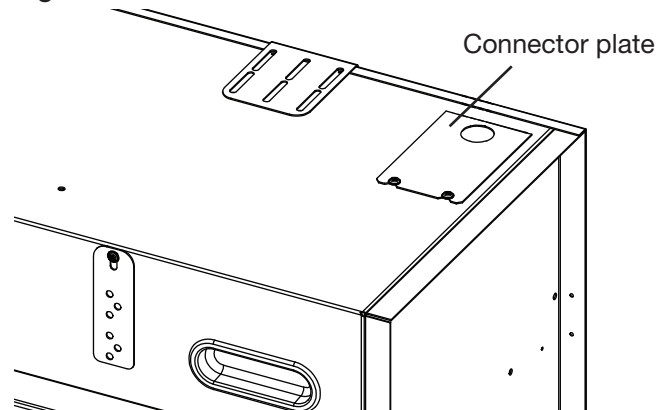

Figure 8



Installation

Water Supply Connection

⚠ CAUTION: Ensure that all plumbing connections meet local plumbing code requirements. Ensure that the location of the plumbing connection allows for easy access to allow for shutoff during scheduled maintenance.

Water Quality

Normal tap water can be used in the Opti-myst®. In areas with hard water, a water softener is recommended and more frequent cleaning and maintenance may be required. Unfiltered water supplied from a well or another unmonitored supply is not recommended. The product is provided with an in-line mesh filter to help remove contaminants and extend the life of the product.

Plumbing Instructions

The units are designed to be hard plumbed by connecting to a water source using standard ¼" (6.4 mm) O.D. tubing. A plumbing accessory kit CDFIPLUMB-KIT, designed for use with copper piping, is available from your Dimplex dealer.

1. Prepare a cold-water line in the vicinity of the desired installation location of the fireplace. Ensure that the location of the plumbing connection allows for easy access to allow for shutoff during scheduled maintenance.

! NOTE: Once the new plumbing connections are complete ensure that the lines are flushed to prevent any debris from going into the unit.

2. Lift the media tray out of the unit and set it aside.

3. Connect the water line, reduced to ¼" tubing, to the main valve located in the bottom left side of the unit. (Figure 6)

⚠ CAUTION: Ensure that the end of the tubing is cut square to prevent leaking.

4. Connect the water supply tubing to the main water valve by removing the locking ring and inserting the tubing so that it is fully inserted (approximately ½" [12 mm]). Reinstall the locking ring.

5. Complete electrical installation steps before opening the main water valve.

6. Priming (pre-filling with water) is required. See *Priming the Unit* on page 22.

Figure 9

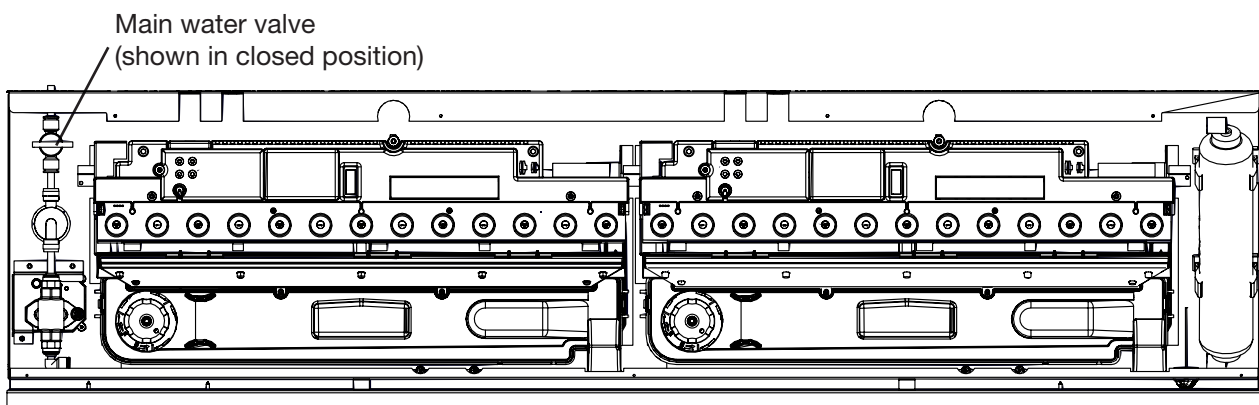

Refillable Water Containers

! NOTE: Not recommended for applications with frequent use.

If direct connection to a water supply is not possible, the reservoir can be manually filled using an Opti-Myst refillable container (9601350100RP) (not provided) which can be purchased at www.dimplex.com/replacement_parts. One container will be needed for each flame module in the fireplace. One refill will provide up to 6 hours of flame operation. The front glass and media tray will need to be removed each time the containers need to be refilled.

Installation

Electrical Installation

⚠ WARNING:

The installation of the electric fireplace must comply with the applicable Local and/or National Electrical Codes and utility requirements.

Use the appropriate wire to meet local and national electrical codes for rated power consumption.

⚠ CAUTION: A dedicated, properly fused 15 Amp circuit is recommended, rated for the appropriate voltage (120 V, 240 V). A dedicated circuit will be required if, after installation, the circuit breaker trips or fuse blows on a regular basis when the heater is operating. Additional appliances on the same circuit may exceed the current rating of the circuit breaker.

120 V Hardwire Installation

! NOTE: For OLF86-AM, when connected to 120 V, there will be no heat output, but heat functions will be active on the controls with only fans operating.

1. Connect the black L1 wire from the unit to the live wire from the power supply with a wire connector.
2. Connect the white N wire from the unit to the neutral wire from the power supply with a wire connector.
3. Connect the green G wire from the unit to the ground wire from the power supply with a wire connector or attach the grounding wire to the cover with the provided grounding screw, by placing the wire in between screw and lock washer and tighten.
4. Ensure all wire connections are tight.

Figure 10

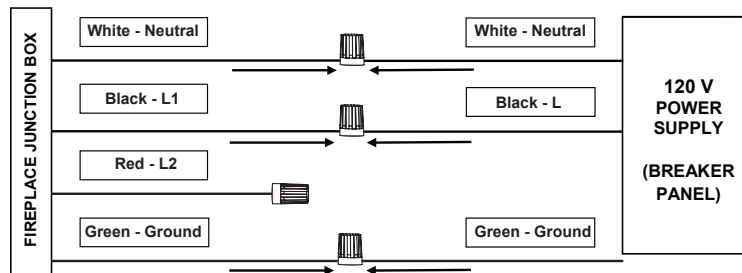

Installation

240 V Hardwire Installation

You will need a 4-wire 240 V supply (L1, L2, Neutral, and Ground).

1. Connect the black L1 wire from the unit to the L1 wire from the power supply with a wire connector.
2. Connect the red L2 wire from the unit to the L2 wire from the power supply with a wire connector.
3. Connect the white N wire from the unit to the neutral wire from the power supply.
4. Connect the green G wire from the unit to the ground wire from the power supply with a wire connector or attach the grounding wire.
5. Ensure all wire connections are tight.

Figure 11

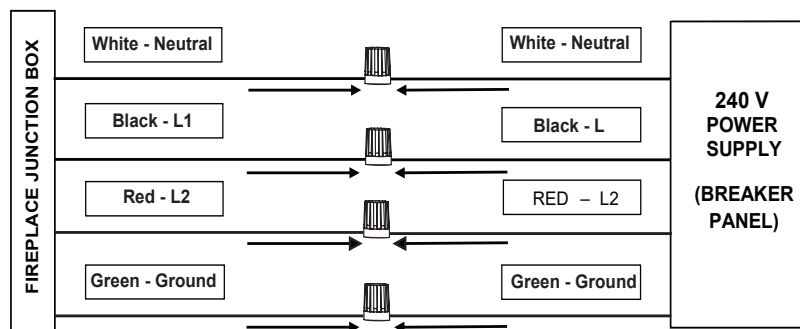

Optional Plug Kit (OLFPLUG, sold separately)

⚠ WARNING: Power cord option is only suitable for 120 V installations.

1. Remove the 3 screws that hold the connector plate.
2. Connect the black L1 wire from the unit to the black wire of the plug kit.
3. Connect the white N wire from the fireplace to the white wire from the plug kit.
4. Connect green G wire from the fireplace to the green wire from the plug kit.
5. Ensure all wire connections are tight.
6. Secure the power cord's pre-installed cover plate using the screws removed when removing the connector plate. The previously removed connector plate can be disposed of.

⚠ WARNING: This heater is not intended for use with an extension cord. Plug the cord directly into an appropriate wall receptacle.

Figure 12

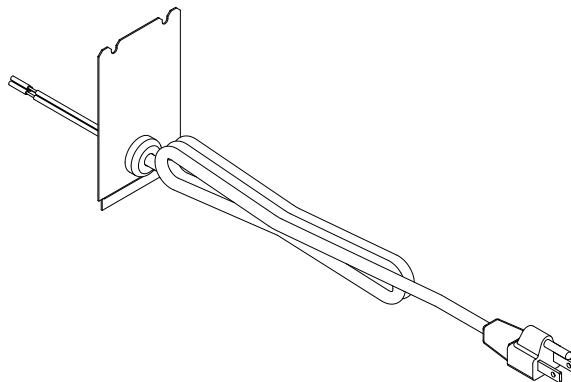

Heater Hardware Disconnect

The fireplace heater can be permanently disabled by removing the electronic jumper on the main control board.

Heater hardware disconnect will permanently disable the heater and fan function. Follow these instructions **ONLY** when an installation without heat is required. Temporary disabling of the heater can be achieved through the hidden touch controls. See “Heat Disable” in *Operation* section (page 20) for instructions.

The recirculating fan and the element in the flame module will not be disabled.

To disconnect the heater and fan permanently:

1. Remove the screws that secure the right-side upper LED lights and disconnect the wire.
2. Remove the screws that secure the right-side upper panel. Carefully lower the upper panel, which is held by hinges to the housing.
3. Locate the main control board. The heater hardware disconnect jumper location is labeled “J2”. (Figure 13)
4. Remove the heater hardware disconnect jumper.
5. Secure the upper panel back in its original position.
6. Reconnect the wire for the upper LED lights, and secure in place.

Figure 13

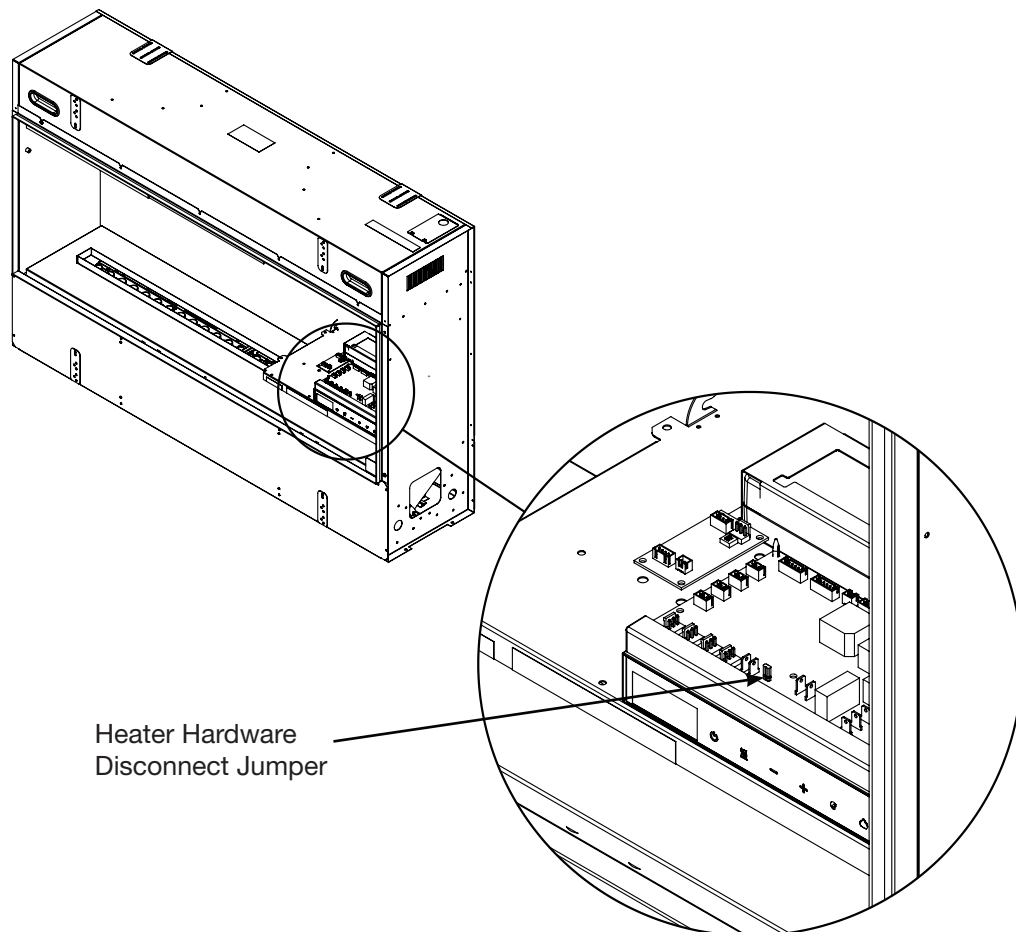

Installation

Flame Baffles

The unit comes with breakable and slotted baffles to create a customized flame. The unit can be operated with or without the baffles. The baffles will create spacing to customize a unique flame appearance.

Separate the **breakable baffles** by bending the strip until it breaks into 4 single baffles. (Figure 15) The **slotted baffles** are not breakable. (Figure 16)

To insert the baffles, use a screwdriver to carefully pry open the flame output slot on the top cover. (Figure 14) Install the baffle by putting the side with the two tabs down, and inserting it so that the lip on the top cover goes over the baffle.

Place the breakable baffles across the flame output slot as desired to create the desired flame appearance.

Three slotted baffles are required to cover each flame output slot.

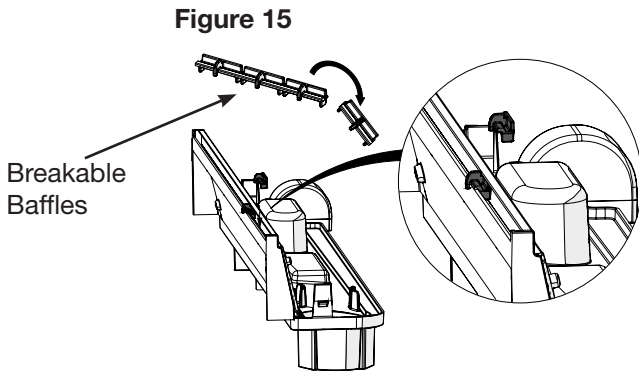
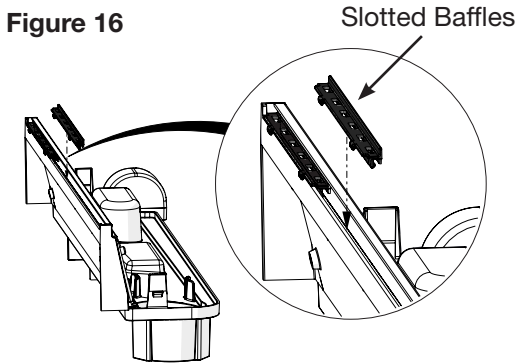
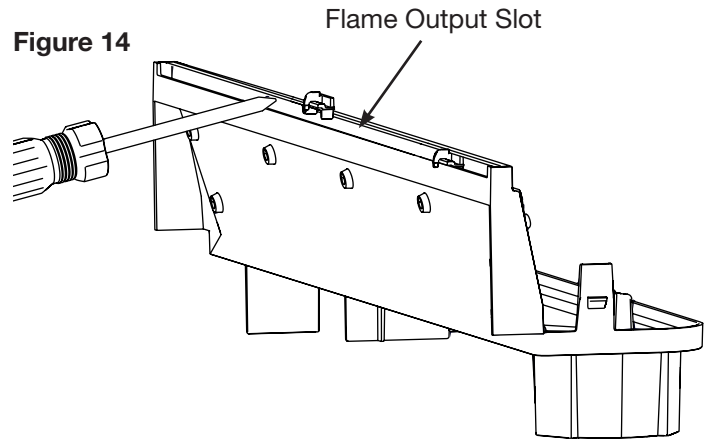

Media Arrangement

1. Install media bed with the angled side of the slot toward the back of the fireplace. (Figure 17)
2. Evenly disperse the small crystals to entirely cover the media bed.
3. Place the driftwood pieces across the crystals.
4. Place the large and extra-large crystals as desired over the smaller crystals and beside the driftwood.

! NOTE: It is not recommended to position the driftwood pieces across the flame output slot. If this configuration is desired, use the provided baffles to block the mist beneath the log(s) to prevent condensation.

It is possible to use custom media ornaments to decorate your fireplace. The custom media must fit easily without scratching the glass or bowing the media bed, and must not be composed of sand or liquid, which could interfere with the safety of the fireplace.

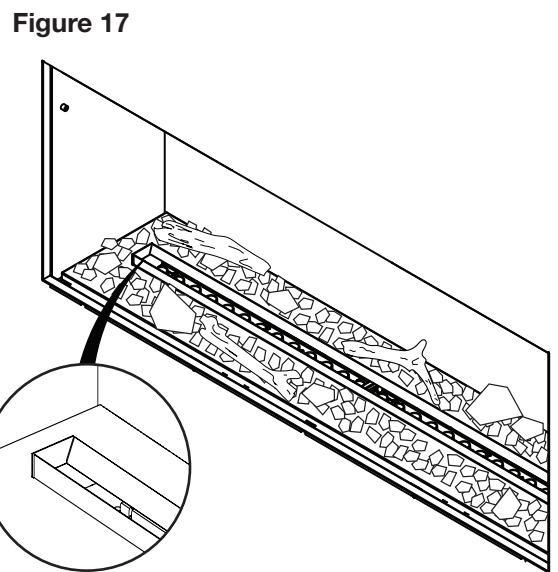

Front Glass Installation

! **NOTE:** Two people are required for installation of the front glass.

! **NOTE:** Turn on the power switch before installing the front glass. The power switch is located in the upper right corner inside the firebox.

1. Ensure there are no debris or finger prints on the inner side of the front glass before you begin.
2. Attach the provided suction cups to the outer side of the front glass. Ensure the suction cups are securely attached.
3. Using the suction cups to assist, lift the glass and place it directly in front of the media bed at a slight angle.
4. Lift the front glass slightly to hook the front glass onto the posts on each side of the fireplace. (**Figure 18**)

! **NOTE:** When installed correctly, the front glass should not obstruct the hidden touch controls.

5. Remove the suction cups and clean any fingerprints or debris off the glass with a nonabrasive glass cleaner.

! **NOTE:** Do not dispose of the suction cups! Keep them in a secure location, as they may be needed for maintenance and service on this fireplace.

Figure 18

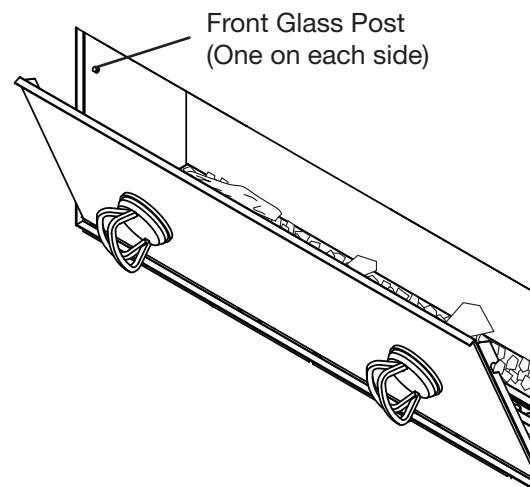

Operation

General Operation

⚠ WARNING: This electric firebox must be properly installed before it is used.

This firebox operates with ComfortSaver™ technology, which automatically adjusts the fan speed and heater wattage to safely and precisely match the requirements of the room based on the thermostat setting.

! NOTE: The element retains heat after shutdown. When the heat is turned off, there is a 30-second cool down period before the fan shuts off completely.

! NOTE: After a power interruption the fireplace will return to Standby mode and retain the previously used settings.

Power Switch

The main power (On/Off) switch is located behind the front glass in the upper right corner inside the fireplace.

Hidden Touch Controls

The hidden touch controls are located on the upper right of the fireplace. (Figure 19) To activate the controls touch the area next to the display. After 20 seconds of inactivity, the controls return to the hidden state.

! NOTE: When in standby mode, the  remains illuminated.

Remote Operation

The fireplace is supplied with a multifunction Bluetooth remote control. (Figure 20)

App

The fireplace is capable of being controlled using the Flame Connect app for mobile devices. For up-to-date information about the app, please visit www.dimplex.com/fcapp.

! NOTE: The fireplace will not operate using the provided remote control when the app is open on a paired mobile device. A blue LED indicator will illuminate on the fireplace display when the app is in use.

Figure 19

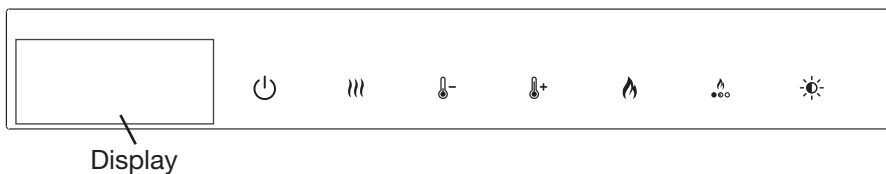
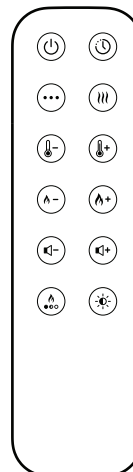

Figure 20



Operation

! NOTE: The touch screen display needs to be touched once before activating any functions below.

	Standby	<p>Press to turn on the unit or to put it in standby mode. There is a brief delay after pressing before the unit turns on.</p> <p>When the unit is turned on, there is a 3-minute warm-up sequence before the flame effect starts.</p>
	Heat	<p>Press to turn the heat on or off.</p> <p>When the heat is turned on, the display briefly indicates the set temperature (<i>##5T</i>), followed by the ambient room temperature.</p> <p>When the heat is turned off, the fan continues to operate for a further 30 seconds to dissipate residual heat.</p>
	Heat Disable	<p>Press and hold and at the same time for 3 seconds to disable or enable the heat function. This action must be performed on the hidden touch controls.</p> <p>When the heat is disabled and is pressed, <i>LOSD</i> appears on the display.</p>
	Increase Temperature	<p>Press to increase the temperature setting.</p> <p>The temperature can be set from 15° C to 30° C (59° F to 86° F).</p>
	Decrease Temperature	<p>Press to decrease the temperature setting.</p>
	Temperature Display (°C ↔ °F)	<p>Press and hold and at the same time for 3 seconds to change the displayed temperature unit. This action must be performed on the hidden touch controls.</p>
	Flame Intensity	<p>Press repeatedly to adjust the flame intensity setting. The display indicates <i>LOW</i>, <i>MED</i> (medium), or <i>HIGH</i>.</p> <p>! NOTE: Allow 15 minutes of operation before adjusting the flame intensity.</p>
	Extractor Fan Boost	<p>The extractor fan boost clears any excess fogging that may appear in the fireplace.</p> <p>Press and hold for 5 seconds to turn on the extractor fan boost. Once finished, the flame will resume on the low setting. This action must be performed on the hidden touch controls.</p>
	Ambient & Flame Theme	<p>Press repeatedly to cycle the 8 different Ambient & flame color themes:</p> <ul style="list-style-type: none"> 1 - Natural Flame 2 - Blue 3 - Violet 4 - Red 5 - Aquamarine 6 - Prism Mode - media and overhead lights cycle through colors 7 - Kaleidoscope Mode - media and overhead lights cycle through colors at different rates. 8 - Custom (app required)
	Brightness	<p>Press repeatedly to cycle the top light brightness settings:</p> <ul style="list-style-type: none"> 1 - Brightness level 1 2 - Brightness level 2 3 - Brightness level 3 4 - Brightness level 4 5 - Brightness level 5 6 - Pulsating effect

Operation

Additional Functions to be Performed from the Remote Control



Timer

Press  repeatedly to set the duration of the timer. The fireplace goes into standby after the time has elapsed. The timer can be set from 30 minutes (display shows *0.5HR*) to 8 hours in intervals of 30 minutes.

To turn the timer off, press  after 8 and the display indicates *OFF*.

While the timer is active, press the timer button to see the time remaining.



Heat Mode Selection

Press  repeatedly to cycle through the different heat modes:

Normal: The heater automatically adjusts to achieve and maintain the set temperature.

Eco: The heater will work at reduced power to save energy.

Heat Boost: The heat is on at maximum power for a preset amount of time before reverting to normal heat mode. Select *BST1* for 5 minutes, *BST2* for 10 minutes, or *BST3* for 15 minutes.

Frost Protection: The heater maintains the ambient temperature at 7° C (45° F). To indicate this mode, overhead lights are blue and the display indicates *-FP-* continually. The flame effect cannot be turned on in this mode.

Fan: The fan runs without heat to circulate the air in the room.



Increase Flame Intensity

Press  to increase the flame intensity setting to *MED* (medium) or *HIGH*.



Decrease Flame Intensity

Press  to decrease the flame intensity setting to *LOW* or *MED* (medium).



Increase Volume

Press  repeatedly (or press and hold) to decrease the volume level of the crackling sound effect.



Decrease Volume

Press  repeatedly (or press and hold) to increase the volume level of the crackling sound effect.

The volume of the crackling sound effect can be set from OFF to level 6.

Press  or  to briefly display the current volume setting.

Resetting the Temperature Cutoff Switch



Should the heater overheat, a manual limit cut-out will turn the unit off and it will not come back on without being reset. It can be reset by turning the unit off from the main ON/OFF switch or at the main disconnect panel and waiting 10 minutes before turning the unit back on.

⚠ CAUTION: If you need to continuously reset the heater, turn the unit off at the main disconnect panel and call technical support at: 1-888-346-7539.

Factory Reset

Performing a factory reset will restore all settings to default, disconnect the unit from the mobile app if connected, and remove any primary and guest users. This can also help resolve issues connecting to the Flame Connect App.





To reset all the settings to factory default:

1. Turn the power off for 10 seconds at the main power switch.
2. Turn the power back on. The unit will start the warm-up sequence.
3. Once the warm-up sequence is complete, press and hold  and  at the same time for 10 seconds. This action must be performed on the **hidden touch controls**.

Priming the Unit

The unit will need to be primed with water prior to the first use and whenever the sumps are fully emptied (such as after cleaning or maintenance).

Once the unit is connected to water and electrical supply, prime the unit using the hidden touch controls (**Figure 19**) by following these steps:

1. Ensure the water valve is open. (**Figure 9, page 13**)
2. Put the power switch in the “on” position.
3. While the unit is in standby mode, press and hold  for 5 seconds. The unit will remain in standby and the flame intensity icon () will illuminate.
4. Press and hold  for 3 seconds. “*FILLING*” will scroll across the display for the duration of the priming. Once the filling is complete, the display will show “*FULL*”, the  icon will disappear, and 4 beeps will follow. The unit will return in standby mode.
5. To start the unit press  once. The warm up sequence will start.

Remote Control Battery Replacement

To replace the batteries:

1. Remove battery cover of the remote control using a Philips screwdriver.
2. Correctly install two 3 Volt (CR2032 or similar) battery in the battery holder with the + side facing up.
3. Secure the battery cover using the previously removed screw.



Batteries must be recycled or disposed of properly. Check with your Local Authority or Retailer for recycling advice in your area.

Figure 21

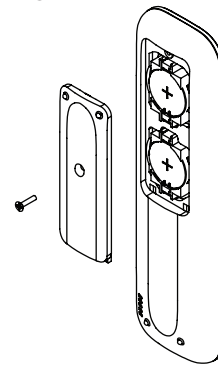

Cleaning

⚠ WARNING: Disconnect power and allow heater to cool before attempting any maintenance or cleaning to reduce the risk of fire, electric shock or damage to persons.

⚠ CAUTION: The heater should not be operated with an accumulation of dust or dirt on or in the unit, as this can cause a build-up of heat and eventual damage. For this reason the heater must be inspected regularly, depending upon conditions and at a minimum yearly intervals.

Fireplace Surface Cleaning

Use only a damp cloth to clean the glass and painted surfaces of the fireplace. The inner side of the glass may occasionally get cloudy and require cleaning. Do not use abrasive cleaners.

Component Cleaning

It is required that the top cover, sump, water bottle (if used), and transducers are cleaned with soap and water on a regular basis, **at a minimum once per month**. More frequent cleaning may be required depending on water quality.

⚠ CAUTION: Do not put plastic components in the dishwasher.

The air filters can be removed and gently rinsed with water to clean and dried on a towel before reinstalling. Reinstall the filter so that the coarse black side of the filter is facing the back of the unit.

Figure 22

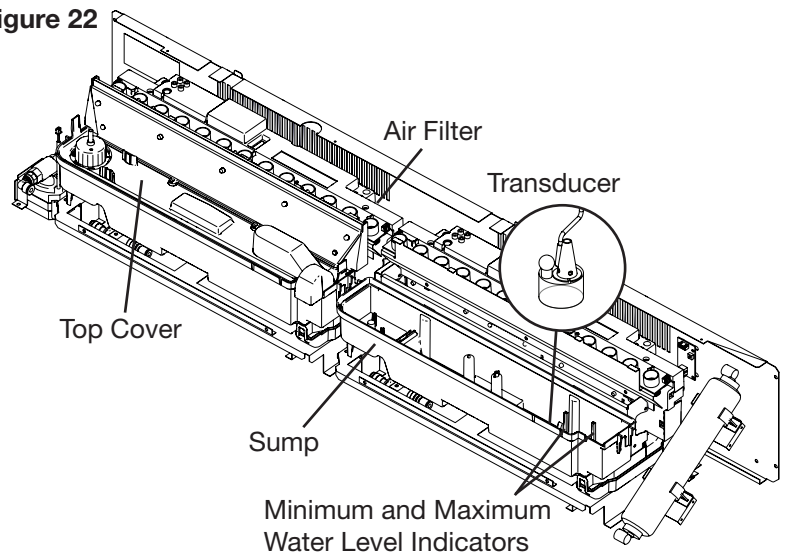

Transducer Replacement

After prolonged use, the ability for the unit to produce mist may become reduced. If cleaning does not improve the performance of the flame effect, replacement of the transducer may be required. This unit comes with replacement transducers. Additional transducers may be purchased at www.dimplex.com/replacement_parts (9601210100RP).



! NOTE: To remove the transducer, release the retaining tab in the sump and remove transducer.

Servicing



Except for installation and cleaning described in this manual, an authorized service representative should perform any other servicing.

Troubleshooting

For more troubleshooting, consult the OLF Service Manual which can be found at www.dimplex.com/customer_support/technical_and_troubleshooting

Problem	Display	Cause	Solution
Fireplace does not turn on with the manual touch controls	N/A	Normal operation	There is a brief delay after pressing  .
		No incoming power	Ensure the power switch is on. Ensure unit is wired correctly. Check main disconnect panel.
	 40	Hidden touch controls error	See service manual.
Fireplace does not respond to commands given from the remote control	N/A	The batteries in the remote control are dead or installed incorrectly.	Replace remote control batteries. Ensure batteries are installed with + facing up.
	Blue LED	The Flame Connect app is open on a mobile device.	Close the Flame Connect app on all mobile devices to enable use of the remote control.
	N/A	Remote control not synced to fireplace.	Restart the unit by turning the power off from the power switch or breaker for 10 seconds before turning it back on. Press any button on the remote control.
Heater is on, but there is no heat	-##5T-	The temperature setpoint is below the ambient temperature.	Increase the temperature setting, so that it is above the ambient temperature.
Circuit breaker trips or fuse blows when unit is turned on	N/A	Improper circuit current rating	Install unit on a dedicated minimum 15 amp circuit.
The glass is fogging	N/A	Excess humidity	Use the Extractor Fan Boost as needed to clear excess humidity within the unit. (See page 20) If fogging persists, reduce the flame intensity.
The flame effect is not uniform across all modules	N/A	Normal operation; a slight variation in the thickness and height of the flame effect from one module to the other is expected.	No action required.
		Normal operation upon startup.	Allow the unit to warm up for 10 to 15 minutes for the height of flame effect to stabilize.
		Transducer is not operating optimally.	Clean module components, including transducer. If problem persists, replace transducer.

Troubleshooting

Problem	Display	Cause	Solution
Heat does not turn on	E152	Heater is disabled.	Press and hold  and  at the same time on the hidden touch controls for 3 seconds to disable or enable the heat function.
	E143	Heater has been permanently disabled.	If installation with heat is desired, reinstall jumper wire on main board if available or purchase new main board.
	E120	Ambient temperature NTC error	See service manual.
	E123	Onboard NTC error	Turn unit off from power switch. Check for heater exhaust blockage. Allow the unit to cool for 30 minutes. If error persists, see service manual.
	E133	Main PCB overheat detected	Turn unit off from power switch. Allow the unit to cool for 30 minutes. If error persists, see service manual.
Flame effect does not turn on In some cases, the display an error code followed by an # to indicate which sump(s) registered the error. For example, where there are three flame modules and the middle one is affected, the display will flash the error code, followed by _#_.	E134	Heater fan error	See service manual.
	E144	Extractor fan(s) error	See service manual.
	E145	Incorrect number of modules detected.	See service manual.
	E151	Low water level in one of the sumps.	Restart the unit by turning the power off from the power switch or breaker for 10 seconds before turning it back on. Check plumbing connections. If error persists, see service manual.
	E15b	The timing for filling the sump has been maxed out.	Restart the unit by turning the power off from the power switch or breaker for 10 seconds before turning it back on. Check water pressure and plumbing connections. If error persists, see service manual.
	E157	Possible leak in the unit.	Inspect the modules for any leaks. If error persists, replace reed switch.
Flame Connect App-related error	E158	Overflow has been detected.	Inspect the modules and carefully remove excess water. See service manual.
	E153	Fireplace settings are out of sync with the app.	Open the app on your mobile device to synchronize settings.

Wiring Diagrams

OLF46-AM

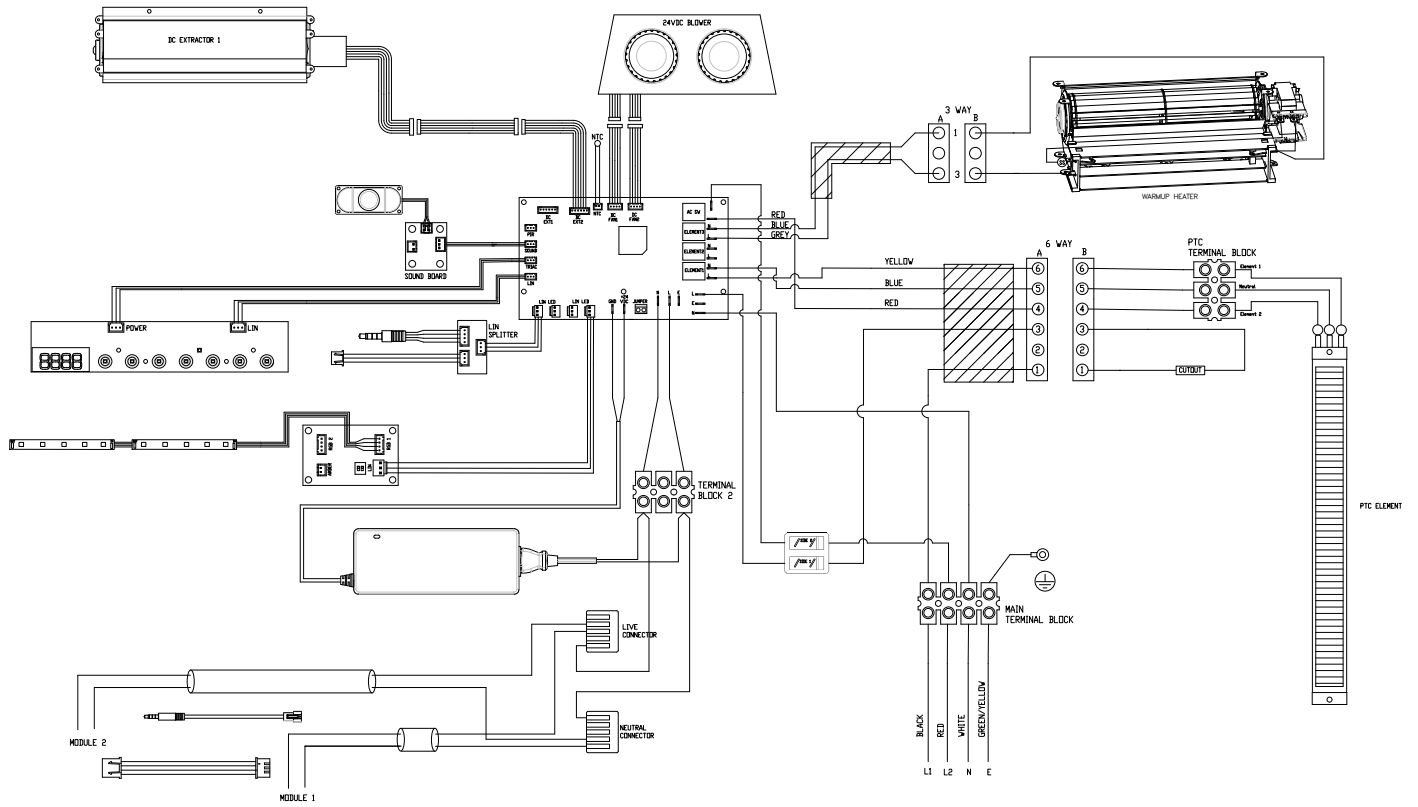

OLF66-AM

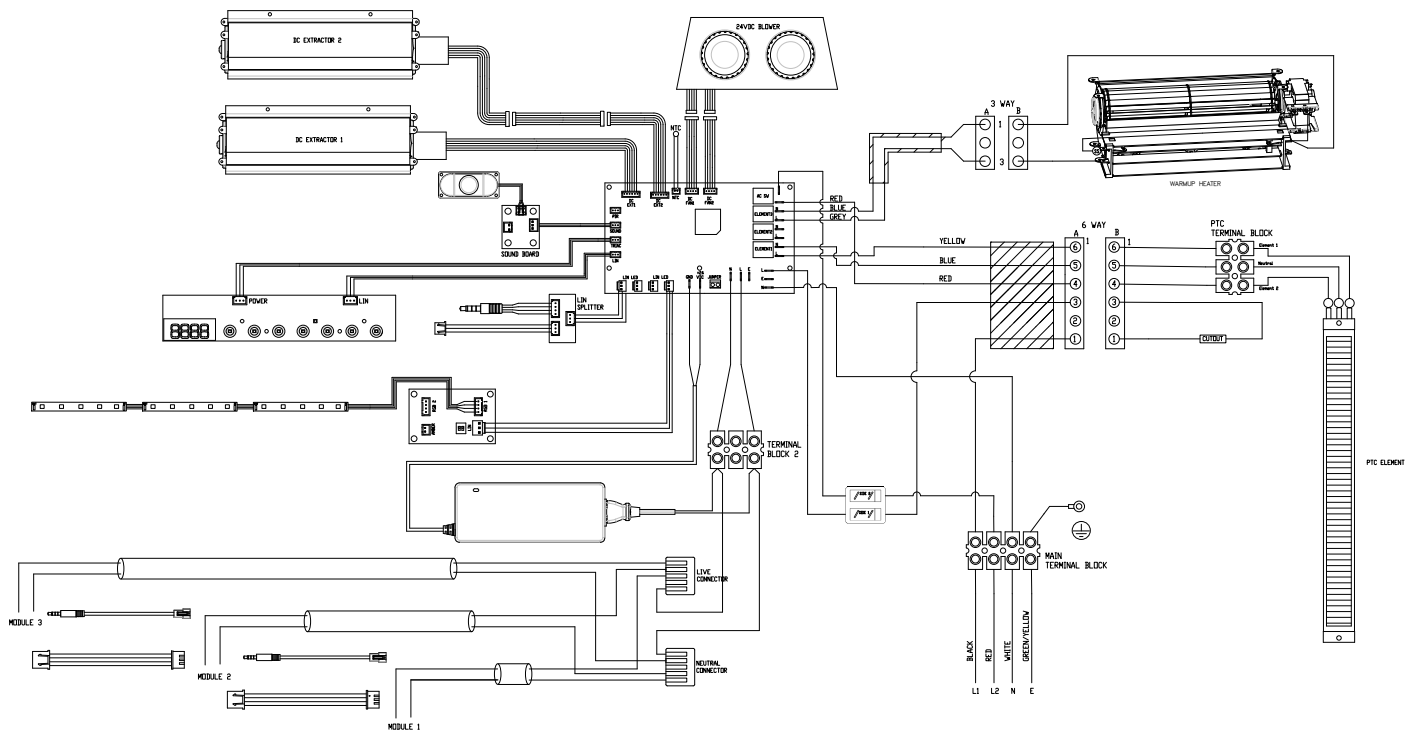

Wiring Diagrams

OLF86-AM

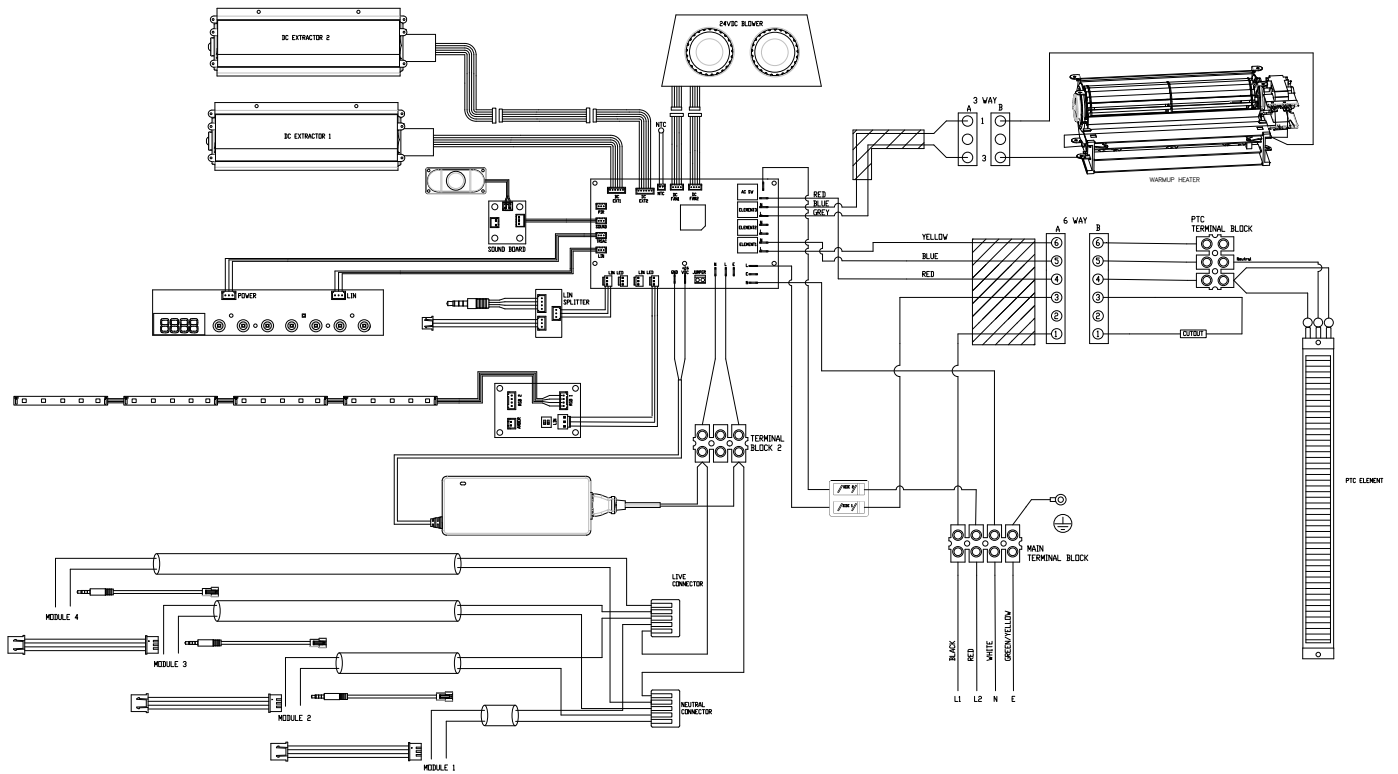

Warranty

OPTI-MYST LINEAR™ 2-YEAR LIMITED WARRANTY

Section 1 Products to which this Limited Warranty Applies

This Limited Warranty applies to your newly purchased Dimplex electric fireplace with model numbers OLF46-AM, OLF66-AM, and OLF86-AM.

This Limited Warranty applies only to purchases made in any province of Canada except for Yukon Territory, Nunavut, or Northwest Territories or in any of the 50 States of the USA and the District of Columbia except for Hawaii and Alaska. This Limited Warranty applies to the original purchaser of the product only and is not transferable.

Section 2 Products excluded from this Limited Warranty

Products purchased in Yukon Territory, Nunavut, Northwest Territories, Hawaii, or Alaska are not covered by this Limited Warranty. Products purchased in these States, Provinces, or Territories are sold AS IS without Warranty or condition of any kind including, without limitation, any implied warranties or conditions of merchantability or fitness for a particular purpose. The entire risk of as to the quality and performance of the products is with the purchaser. In the event of a defect, the purchaser assumes the entire cost of all necessary servicing or repair.

Section 3 What this Limited Warranty covers and for How Long

Opti-Myst Linear™ products OLF46-AM, OLF66-AM, and OLF86-AM excluding trims and accessory packages are covered by this Limited Warranty, have been tested and inspected prior to shipment and, subject to the provisions of this Warranty, Glen Dimplex Americas Ltd. (herein called Glen Dimplex Americas) warrants such products to be free from defects in material and workmanship for a period of 5 years from the date of the first purchase of such products. The 5-year Limited Warranty entitles the purchaser to On-site or In-home Warranty Services. Accordingly, Glen Dimplex Americas will be responsible for all labor and transportation associated with repairing or replacing the product or part. Exceptions to this are outlined in Section 5. Some jurisdictions do not allow limitations on how long an implied Warranty lasts, so the above limitation may not apply to the purchaser.

Section 4 What this Limited Warranty Does Not Cover

This Limited Warranty does not apply to products that have been repaired (except by Glen Dimplex Americas or its authorized service representatives) or otherwise altered. This Limited Warranty does further not apply to defects resulting from misuse, abuse, accident, neglect, incorrect installation, improper maintenance or handling, or operation with an incorrect power source.

Section 5 How to notify us of a Warranty Concern

Defects must be brought to the attention of Dimplex Customer Service online at dimplex.com/en/contact_us or by telephone at 1-888-346-7539. Please have proof of purchase, catalogue/model and serial numbers available for representatives to assist. **Limited In-home Warranty Services require proof of purchase.

In the event a product or part covered by this Limited Warranty is proven to be defective in material or workmanship during (i) the 2-year Limited Warranty period for products outlined in Section 1, you have the following rights:

- Glen Dimplex Americas will in its sole discretion either repair or replace such defective product or part without charge. If Glen Dimplex Americas is unable to repair or replace such product or part, or if repair or replacement is not commercially practicable or cannot be timely made, Glen Dimplex Americas may, in lieu of repair or replacement, choose to refund the purchase price for such product or part.
- Limited Warranty service will be performed solely by dealers or service agents of Glen Dimplex Americas authorized to provide Limited Warranty services.
- This 2-year Limited Warranty entitles the purchaser to On-site or In-home Warranty services. Accordingly, Glen Dimplex Americas will be responsible for all labor and transportation associated with repairing or replacing the product or part except as follows: (i) charges which may be levied for travel costs incurred to travel to the purchaser's site where the product is located if the purchaser's site is beyond 30 miles (48 km) from the closest service depot of Glen Dimplex Americas dealer or service agent; and (ii) the purchaser is solely responsible for providing clear access to all serviceable parts of the product.
- Glen Dimplex Americas will not be responsible for, and this Limited Warranty shall not include, any expense incurred for installation or removal of the surrounds (mantels) or trims or any part thereof (or any replacement product or part) including, without limitation, all shipping costs and transportation costs to and from the authorized dealer's or service agent's place of business and all labor costs. Such costs shall be the purchaser's sole responsibility.

Section 6 When Glen Dimplex Americas and its Dealers and Service Agents are not Liable

IN NO EVENT WILL GLEN DIMPLEX AMERICAS, OR ITS DIRECTORS, OFFICERS, OR AGENTS, BE LIABLE TO THE PURCHASER OR ANY THIRD PARTY. WHETHER IN CONTRACT, IN TORT, OR ON ANY OTHER BASIS, FOR ANY INDIRECT, SPECIAL, PUNITIVE, EXEMPLARY, CONSEQUENTIAL, OR INCIDENTAL LOSS, COST, OR DAMAGE ARISING OUT OF OR IN CONNECTION WITH THE SALE, MAINTENANCE, USE, OR INABILITY TO USE THE PRODUCT, EVEN IF GLEN DIMPLEX AMERICAS OR ITS DIRECTORS, OFFICERS, OR AGENTS HAVE BEEN ADVISED OF THE POSSIBILITY OF SUCH LOSSES, COSTS OR DAMAGES, OR IF SUCH LOSSES, COSTS, OR DAMAGES ARE FORESEEABLE. IN NO EVENT WILL GLEN DIMPLEX AMERICAS, OR ITS OFFICERS, DIRECTORS, OR AGENTS BE LIABLE FOR ANY DIRECT LOSSES, COSTS, OR DAMAGES THAT EXCEED THE PURCHASE PRICE OF THE PRODUCT. SOME JURISDICTIONS DO NOT ALLOW THE EXCLUSION OR LIMITATION OF INCIDENTAL OR CONSEQUENTIAL DAMAGES, SO THE ABOVE LIMITATION OR EXCLUSION MAY NOT APPLY TO THE PURCHASER.

How State and Provincial law(s) apply

This Limited Warranty gives you specific legal rights, and you may also have other rights which vary from jurisdiction to jurisdiction. The provisions of the United Nations Convention on Contracts for the Sale of Goods shall not apply to this Limited Warranty or the sale of products covered by this Limited Warranty.

We value your feedback!

Your input helps to create even better products and experiences.

Share the warmth and leave a review.

dimplex.com/sharethewarmth

 **YouTube/Dimplex** 



For more information on the Flame Connect app, visit dimplex.com/fcapp



1-888-346-7539 | www.dimplex.com

In keeping with our policy of continuous product improvement, we reserve the right to make changes without notice.

© 2023 Glen Dimplex Americas

 **A BRAND OF GLEN DIMPLEX AMERICAS**