

# URBANA

LUXURY FIREPLACES

## U33I

## U33I-ST

INSTALLATION MANUAL



Intertek  
C#4001609

**WARNING:** If the information in this manual is not followed exactly, a fire or explosion may result causing property damage, personal injury or loss of life. Installation and service must be performed by a qualified installer, service agency or the gas supplier.

CERTIFIED TO: ANSI Z21.88 / CSA 2.33 VENTED GAS FIREPLACE HEATERS  
CSA 2.17 GAS FIRED APPLIANCES FOR HIGH ALTITUDES

C-16923

Retain this manual for future reference.

**WARNING:**

**FIRE OR EXPLOSION HAZARD**

Failure to follow safety warnings exactly could result in serious injury, death, or property damage.

Do not store or use gasoline or other flammable vapours and liquids in the vicinity of this or any other appliance.

**WHAT TO DO IF YOU SMELL GAS**

- Do not try to light any appliance.
- Do not touch any electrical switch; do not use any phone in your building.
- Leave the building immediately.
- Immediately call your gas supplier from a neighbour's phone. Follow the gas supplier's instructions.
- If you cannot reach your gas supplier, call the fire department.

Installation and service must be performed by a qualified Installer, service agency or the gas supplier.

This appliance is only for use with the type of gas indicated on the rating plate. This appliance is not convertible for use with other gases.

Massachusetts installations (Warning): This product must be installed by a licensed plumber or gas fitter when installed within the Commonwealth of Massachusetts. Other Massachusetts code requirements: Flexible connector must not be longer than 36in., A shut off valve must be installed; only direct vent sealed combustion products are approved for bedrooms/bathrooms. A carbon monoxide detector is required in all rooms containing gas fired direct vent appliances. The fireplace damper must be removed or welded in the open position prior to installation of a fireplace insert.

- All Urbana gas-fired appliances must be installed in accordance with their instructions. Carefully read all the instructions in this manual first. Consult the building authority having jurisdiction to determine the need for a permit prior to commencing the installation.
- **WARNING:** Failure to follow these instructions could cause a malfunction of the fireplace, which could result in death, serious bodily injury, and/or property damage.
- Failure to follow these instructions may also void your fire insurance and/or warranty.
- Installation and repair should be done by a qualified service person. The appliance should be inspected before the first use and, at least, annually by a qualified service person. More frequent cleaning may be required due to excessive lint from carpeting, bedding material, etc. It is imperative that the control compartments, burners and circulating air passageways of the appliance be kept clean.
- Due to high temperatures, the appliance should be located out of high traffic areas and away from furniture and draperies.
- Children and adults should be alerted to the hazards of high surface temperatures and should stay away to avoid injury.
- Young children should be carefully supervised when in the same room as the appliance. Toddlers, young children and others may be susceptible to accidental contact burns. A physical barrier is required if there is a risk for individuals in the house. To restrict access to a fireplace or stove, install an adjustable safety gate to keep toddlers, young children and other at risk individuals out of the room and away from hot surfaces. Any safety screen, guard, or barrier removed for servicing an appliance must be replaced prior to operating the appliance.
- Clothing or other flammable materials should not be placed on or near the appliance.
- A barrier designed to reduce the risk of burns from the hot viewing glass is provided with this appliance and shall be installed for the protection of children and other at-risk individuals. If the barrier becomes damaged, the barrier shall be replaced with the manufacturer's barrier for this appliance.

## FOR YOUR SAFETY

- Installation and service must be performed by a qualified installer, service agency, or gas supplier.
- This installation must conform to local codes or, in the absence of local codes, with the National Fuel Gas Code, ANSI Z223.1/NFPA 54, or the Natural Gas and Propane Installation Code, CSA B149.1.
- To prevent injury, do not allow anyone who is unfamiliar with the fireplace to operate it.
- To prevent injury, if the pilot or pilot and burners have gone out on their own, wait 5 minutes to air out before attempting to re-light the appliance.
- Always keep the area around these appliances clear of combustible material, gasoline and other flammable liquids or vapors.
- These appliances should not be used as a drying rack for clothing or for hanging Christmas stockings/decorations.
- Due to the paint curing on the unit, a faint odor and slight smoking will likely be noticed when the stove is first used. Open some windows until the smoking stops.
- Always connect this gas appliance to a vent system and vent to the outside of the building envelope. Never vent to another room or inside the building. Make sure the specified vent pipe is used, properly sized and of adequate height to provide sufficient draft. Inspect the venting system annually for blockage and signs of deterioration.
- **WARNING:** Failure to position the parts in accordance with the diagrams in this booklet, or failure to use only parts specifically approved with this appliance, may result in property damage or personal injury.
- **WARNING:** Do not operate with the glass front removed, cracked, or broken. Replacement of the glass should be done by a licensed or qualified service person.
- Never use solid fuels such as wood, paper, cardboard, coal, or any flammable liquids, etc., in this appliance.
- Do not use this appliance if any part has been under water. Immediately call a qualified service technician to inspect the appliance and to replace any part of the control system or any gas control which has been under water.
- Do not abuse the glass by striking it or slamming the door shut. If the Urbana unit is pulled out of its installation, and the vent-air intake system is disconnected for any reason, ensure that the vent-air intake pipes are reconnected and re-sealed in accordance to the instructions noted in Initial Installation - Direct Vent
- Any safety screen, guard, or barrier removed for servicing an appliance, must be replaced prior to operating the appliance.



# DANGER



HOT GLASS WILL  
CAUSE BURNS

DO NOT TOUCH GLASS  
UNTIL COOLED.

NEVER ALLOW CHILDREN  
TO TOUCH GLASS.

A barrier designed to reduce the risk of burns from the hot viewing glass is provided with this appliance and must be installed for the protection of children and other at-risk individuals.

**DIRECT VENT ONLY:** This type is identified by the suffix DV. This appliance draws all of its air for combustion from outside the dwelling, through a specially designed vent pipe system.

**In the USA:** The appliance may be installed at higher altitudes. Please refer to your American Gas Association guidelines which state: the sea level rated input of Gas Designed Appliances installed at elevations above 2000 (610 m) feet is to be reduced 4% for each 1000 feet (305 m) above sea level. Refer also to local authorities or codes which have jurisdiction in your area regarding the de-rate guidelines.

**In Canada:** When the appliance is installed at elevations above 4500 feet (1372 m), the certified high altitude rating shall be reduced at the rate of 4% for each additional 1000 feet (305 m).

- This appliance has been tested by INTERTEK and found to comply with the established VENTED GAS FIREPLACE HEATER standards in CANADA and the USA as follows:

### VENTED GAS FIREPLACE HEATER (U33I-T NATURAL GAS, PROPANE GAS)

CERTIFIED TO: ANSI Z21.88 / CSA 2.33 VENTED GAS FIREPLACE HEATERS  
CSA 2.17 GAS FIRED APPLIANCES FOR HIGH ALTITUDES

#### This Urbana Fireplace:

- Has been certified for use with either natural gas or propane (see rating label).
- Is not for use with solid fuels.
- Is approved for a bedroom or bed sitting room. (**IN CANADA:** must be installed with a listed wall thermostat. **IN USA:** see current ANSI Z223.1 for installation instructions.)
- Must be installed in accordance with local codes. If none exist, use current installation code CAN/CGA B149.1 in Canada or ANSI Z223.1/NFPA 54 in the USA.
- Must be properly connected to an approved venting system and not connected to a chimney flue serving a separate solid-fuel burning appliance.

**IMPORTANT NOTICE (Regarding first fire up):** When the unit is turned on for the first time, it should be turned onto high for the first 4 hours. This will cure the paint, logs, gasket material and other products used in the manufacturing process. It is advisable to open a window or door, as the unit will start to smoke and can irritate some people. After the unit has gone through the first burn, turn the unit off including the pilot, let the unit get cold then remove the glass door and clean it with a good gas fireplace glass cleaner, available at your local URBANA dealer.

NATIONAL  
FIREPLACE  
INSTITUTE



CERTIFIED

[www.nficertified.org](http://www.nficertified.org)

We recommend that our gas hearth products be installed and serviced by professionals who are certified in the U.S. by the National Fireplace Institute® (NFI) as NFI Gas Specialists.

# Contents

Unit Dimensions.....	6
Rating Label Location.....	6

## Unpacking & Initial Setup 8

Crate Unpacking .....	8
Pallet Bracket Removal .....	9
Lifting Handles .....	9
Fireplace Leveling .....	9
Framing Standoff.....	9
Framing Standoff (Continued) .....	10
Electrical Connection .....	10
Powervent .....	11
Double Sided Glass Option .....	11
Gas Supply Hookup.....	12
Gas Supply Verification .....	12

## Maintenance and Service 13

Screen Removal .....	13
Screen Install.....	13
Glass Removal.....	14
Glass Installation .....	15
Remote Syncing .....	16
Air Shutter (Venturi) .....	16
Electrical, IFC & Valve Access.....	17
Pilot Light.....	17
Baffle Install.....	18
Baffle Removal .....	18
Burner Removal .....	18
Removing Horizontal liners .....	19
Orifice change (Fuel Conversion) .....	20
Fuel Conversion:.....	20
Maintenance and Service .....	21
Activating CSS .....	24
Double Sided Minimum Framing Clearances ...	25
Facing Material & Trim .....	26
Facing Material & Trim .....	26
Corner Install (CSS ONLY) .....	26
Floor Protection.....	26
Initial Startup (Rheostat voltage setting).....	37

## Framing and Installation 27

Outdoor Install: .....	27
Exhaust Restrictor Settings:.....	30
Fully Closed .....	30
Fully Open .....	30
Venting Introduction:.....	30
Allowable Snorkel Installation .....	31
Vertical Termination .....	33
Horizontal Termination: .....	34
Wall / Ceiling Thimble.....	35
Minimum Vent Clearances .....	35
Venting Clearances .....	35
Power vent Unit Connection.....	36
Venting Chart .....	37

## Initial startup & Venting 37

## Parts List 42

## Troubleshooting 45

## Wiring Diagram 46

## Installation Reference Guide 47

## Warranty 48

# URBANA

## LUXURY FIREPLACES

### Unit Dimensions

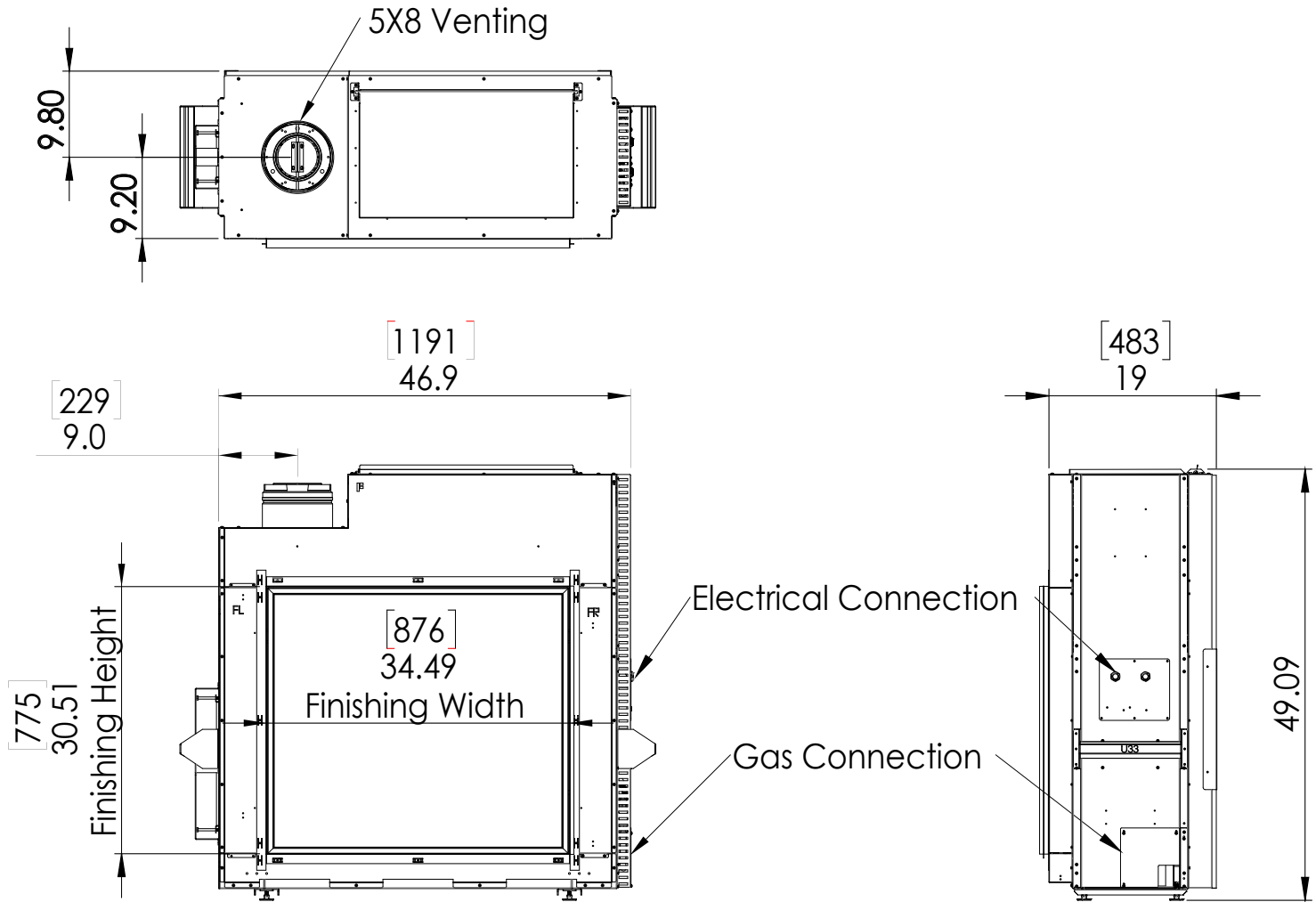

### Rating Label Location

Remove the screen barrier to access the rating label and lighting instructions. The label is attached to a length of wire and is never to be tampered with or removed. All important information for your fireplace is on this label such as the model specific serial number which you will need for warranty information. The label is located inside the front left corner of the cabinet.

**For Your Safety, Read Safety Precautions And  
Lighting Instructions Before Operating**

**WARNING: IF YOU DO NOT FOLLOW THESE INSTRUCTIONS EXACTLY THEN A  
FIRE OR EXPLOSION MAY RESULT, CAUSING PROPERTY DAMAGE, PERSONAL  
INJURY OR LOSS OF LIFE.**

**FOR YOUR SAFETY READ BEFORE OPERATING**

**WARNING: IF YOU DO NOT FOLLOW THESE INSTRUCTIONS EXACTLY, A FIRE OR EXPLOSION  
MAY RESULT CAUSING PROPERTY DAMAGE, PERSONAL INJURY OR LOSS OF LIFE.**

- A. This appliance is equipped with an ignition device which automatically lights the pilot. Do not try to light the pilot by hand.
- B. BEFORE OPERATING smell all around the appliance area for gas. Be sure to smell next to the floor because some gas is heavier than air and will settle on the floor.
- WHAT TO DO IF YOU SMELL GAS:
- Do not try to light any appliance.
  - Do not touch any electrical switch; do not use any phone in your building.
  - Immediately call your gas supplier from a neighbor's phone. Follow the gas supplier's instructions.
  - If you cannot reach your gas supplier, call the fire department.
- C. Use only your hand to push in or turn the gas control knob. Never use tools. If the knob will not push in or turn by hand, don't try to repair it, call a qualified service technician. Force or attempted repair may result in a fire or explosion.
- D. Do not use this appliance if any part has been under water. Immediately call a qualified service technician to inspect the appliance and to replace any part of the control system and any gas control which has been under water.

**OPERATING INSTRUCTIONS**

1. STOP! Read the safety information above on this label.
2. Read the owner's manual including the section on "Remote Control" operation.
3. Set the thermostat to the lowest setting.
4. Turn off all electric power to the appliance.
5. Do not attempt to light the pilot by hand.
6. Wait five (5) minutes to clear out any gas. Then smell for gas, including near the floor. If you smell gas, STOP! Follow "B" in the safety information above on this label. If you don't smell gas, go to the next step.
7. Turn on all electric power to the appliance.
8. Using the remote control, set thermostat to desired setting, or press the ON/OFF key on the remote. "ON" will be indicated on the display of the remote and an audible "beep" will be heard at the unit to indicate the command has been received.
9. This appliance is equipped with a completely automatic ignition and lighting control. The control will attempt to light the pilot several times if necessary. If it is unsuccessful, it will discontinue operations. If the appliance will not operate, follow the instructions "To Turn Off Gas To Appliance" and call your service technician or gas supplier.

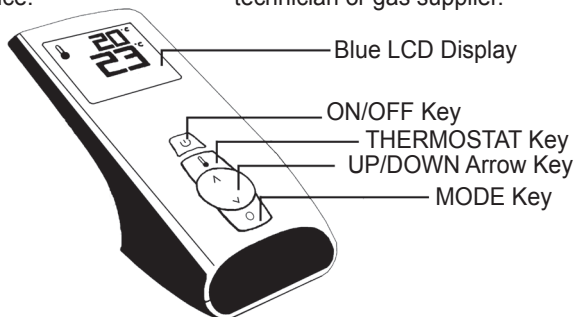

**TO TURN OFF GAS TO APPLIANCE**

1. Set thermostat to lowest setting, or press the ON/OFF Key. "OFF" will be indicated on the display and an audible "Beep" will be heard at the unit to indicate the command has been received.
2. Turn off all electric power to the appliance if service is to be performed.

C-12455

#### Crate Unpacking

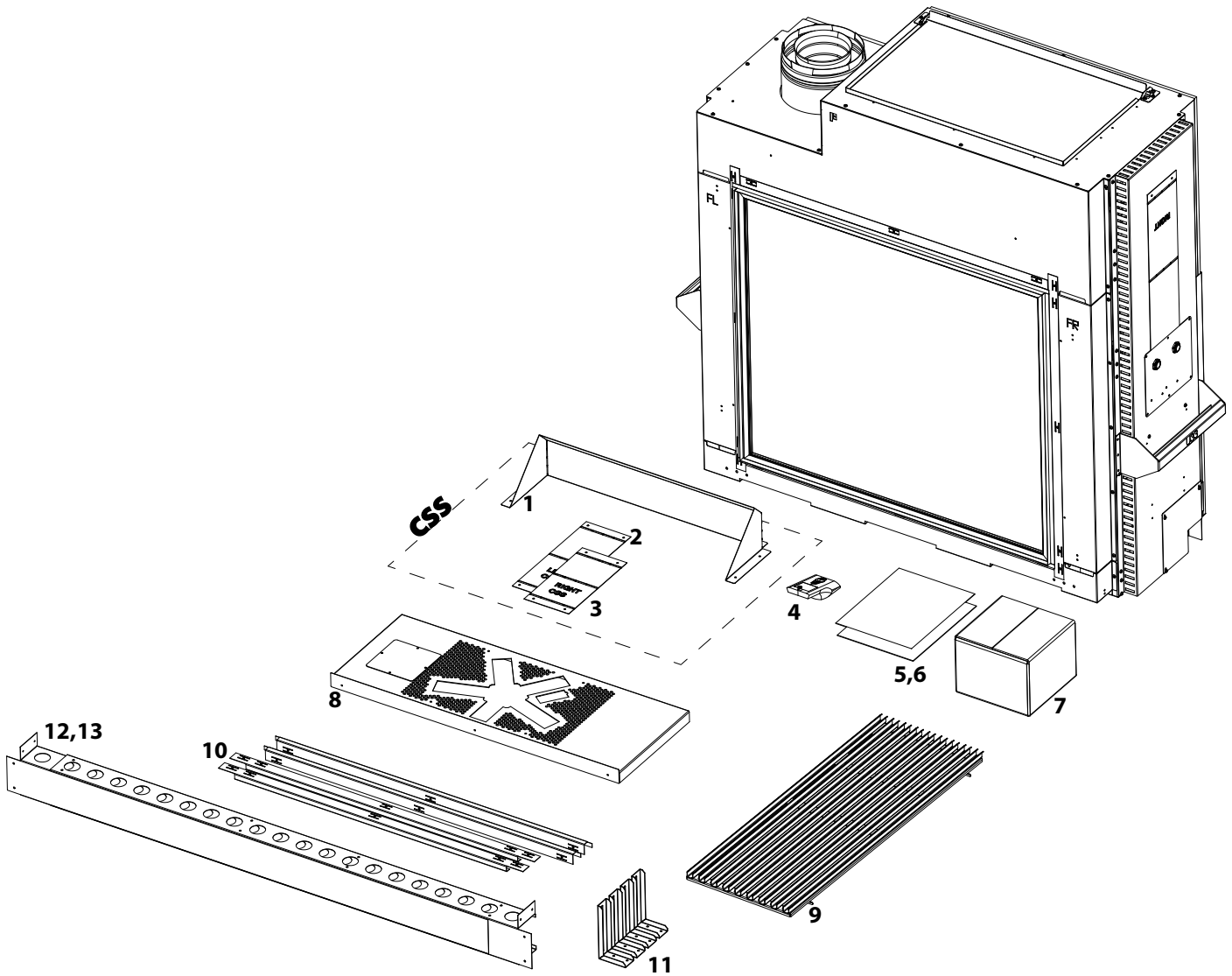

Packing Items							
1) CSS Heat Shield	4) Fireplace Remote	8) Media Tray	11) Floor Bracket				
2) Left Standoff	5,6) Owner & Installation Manual	9) Baffle	12,13) Steel Stud				
3) Right Standoff	7) Fireplace Media	10) Tiling Trim					



## Pallet Bracket Removal

Unscrew the brackets from the pallet. Do not discard. These brackets will be used to secure the unit to the floor when correctly located.

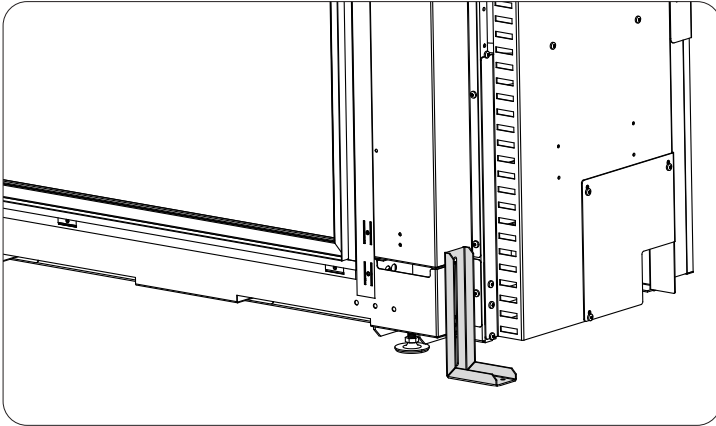

## Lifting Handles

After positioning the unit in place. Remove the lifting handles.

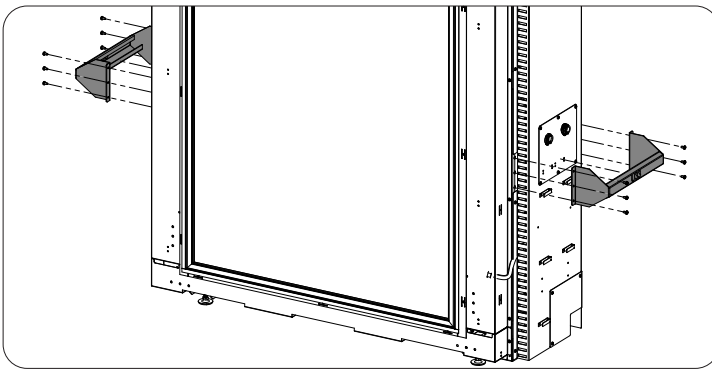

## Fireplace Leveling

### NOTES:

**It is essential to level the unit from proper operation.**

All Urbana units come with leveling feet to accommodate uneven surfaces. The leveling feet can also be used to raise the height of the fireplace up an additional 1" (25 mm). Ensure the fireplace is in its final position before proceeding.

Leveling feet come fully inserted; you will need to unscrew the feet to see any adjustment (no lock nut used). Adjust as follows:

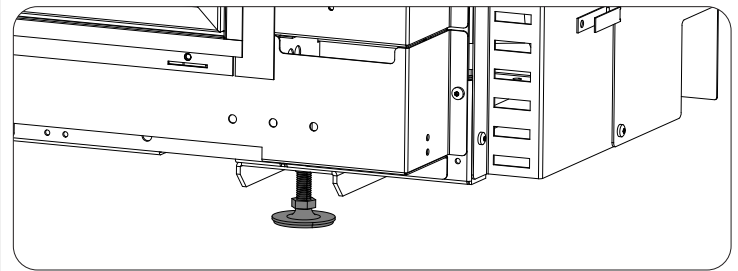

1. Use a level on the top of the unit to determine which feet need adjustment.
2. Use a 9/16 wrench to unscrew the feet to make the necessary adjustments.
3. Verify fireplace is level in all 3 planes.

## Framing Standoff

Framing Standoffs are attached to the unit in their flat position.

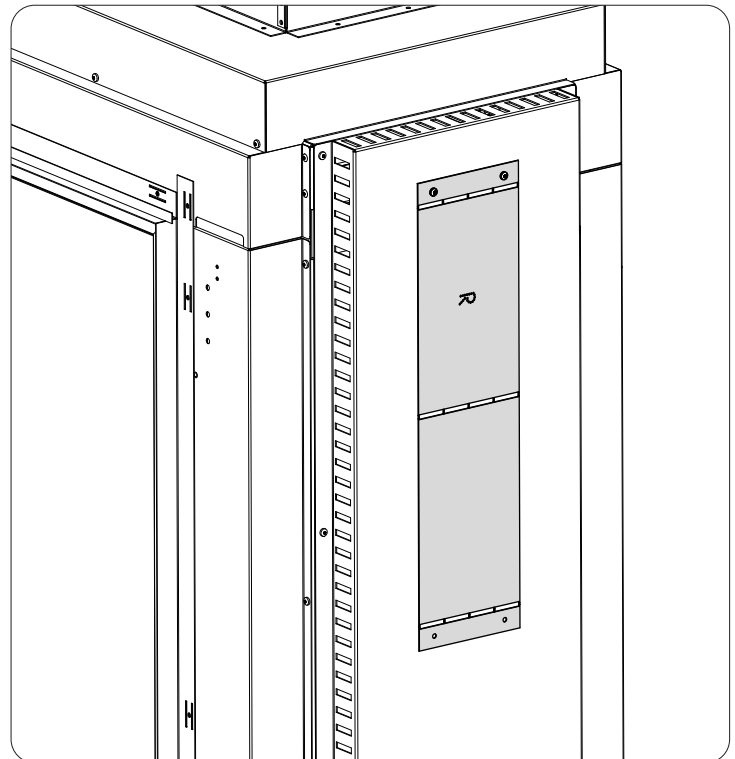

#### Framing Standoff (Continued)

If using the CSS for the installation of this unit you will need to switch the standoffs to the CSS standoff. See Page 24 for more Information Regarding CSS installation.

1. Fold Standoffs into triangles as shown below. The screws are installed into the cabinet. Remove screws and use for the standoff.
2. Repeat for the other side

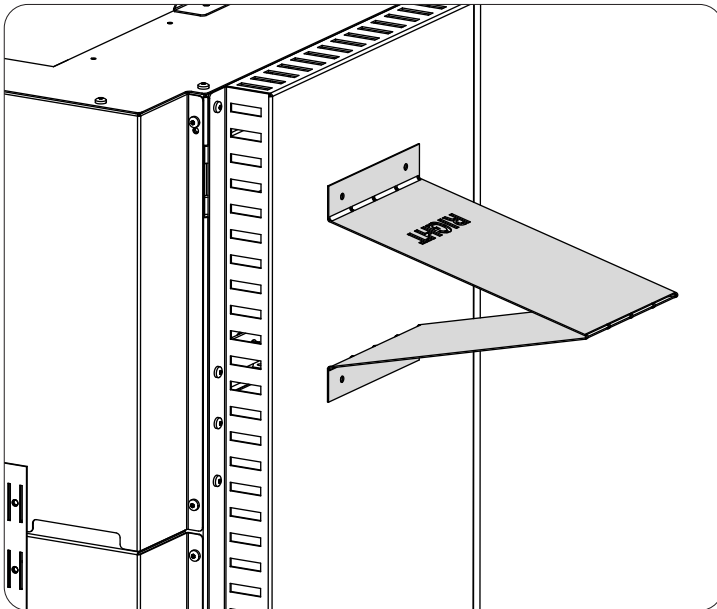

#### Electrical Connection

**WARNING: This fireplace must be electrically connected and grounded in accordance with local codes or, in the absence of local codes, with the current CSA C22.1 Canadian Electrical Code Part 1, Safety Standards For Electrical Installations, or The National Electrical Code ANSI / NFPA 70 in the US.**

Electrical Requirements:

120 VAC. Appliance receptacle must be hard wired with coated 14/2 AWG (minimum) copper electrical wire such as Lumex or Romex. Consult your electrical code for further details. Wire your unit as follows:

1. Run wire to right of unit (see below); be sure wire is NOT live.
2. Remove the cover plate box from the control panel.
3. 120 VAC coming into the unit is passed through into the junction box attached to the cover plate

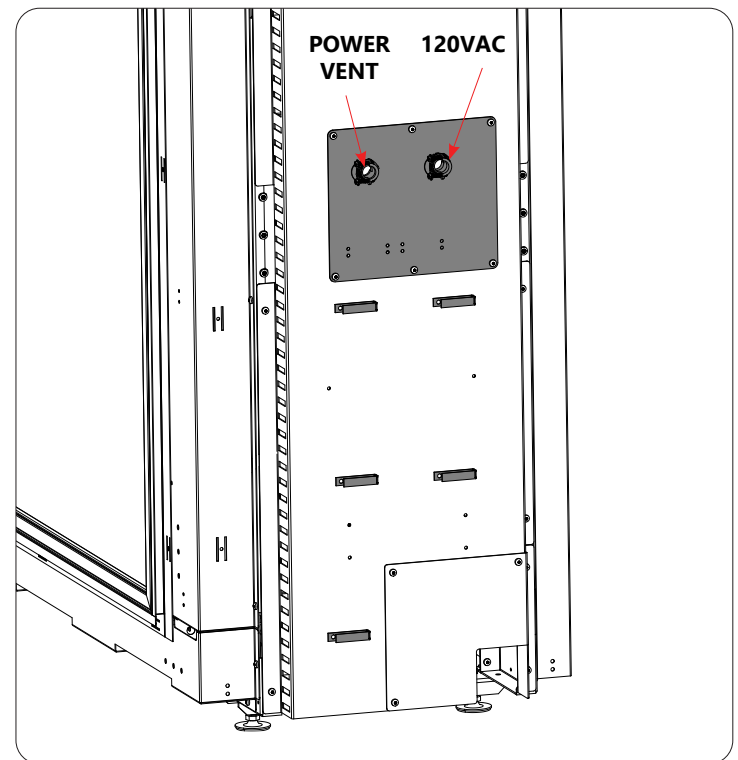

## 4. Use strain relief to secure incoming 120V wire

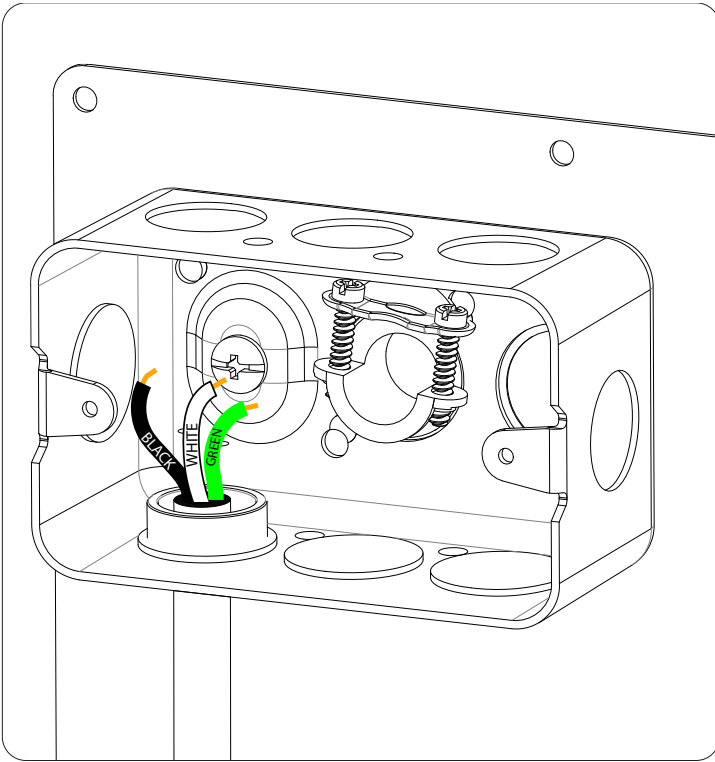

5. Connect the incoming 120 VAC power to the wires inside the junction box, use twist on connector.

6. Replace junction box cover.

## Power vent

The U33I Is Power vent ready, and is only necessary when the venting requirements fall outside of the venting graph on page 28 & 29th.

The U33 can be used with either;

**(50-3883 ) Horizontal Power Vent**

or

**(50-4375 ) Vertical Power vent**

(Both sold separately)

See Page 36 for more information

## Double Sided Glass Option

The U33I can be converted to a see through unit, with glass on both sides. (Sold Separately (50-XXXX)

When converted to see through, the U33i uses all the same framing and venting information as a standard single sided unit.

Instructions on how to install the kit are found in the kit itself.

**NOTE:** Do not spray leak-testing liquid in pressure taps or results will not be accurate.

### Gas Supply Hookup

1. The gas inlet is located on the right hand side of the unit. Remove the cover plate on the bottom of the control panel to gain access to the inlet pipe.
2. After installing gas line, test all gas connections for leaks with soapy water.
3. Replace cover.

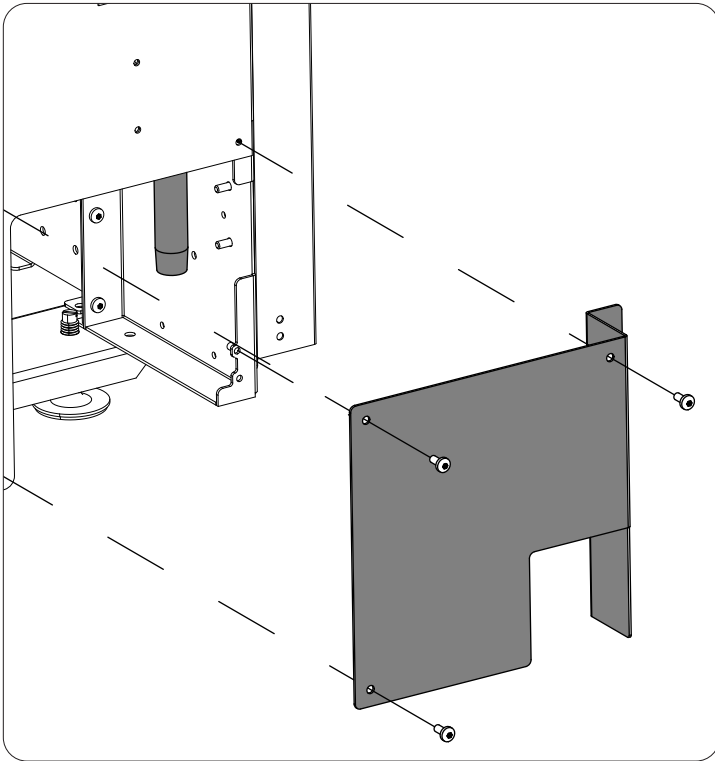

### Gas Supply Verification

Ensure the appliance is seeing correct gas pressures and inputs. Verify the following information matches that of the rating label. Pressure taps are located on the right hand side of unit behind the screen. Remove the screen to access the test taps. A 5/16 (8mm) I.D. hose is required to make the connections. Check gas pressures as follows:

1. Open inlet pressure tap (half turn) and use a manometer to verify inlet pressure with unit running on HI. Pressure cannot exceed 1/2 PSIG (14" W.C.) or valve damage may occur. Adjust inlet pressure as needed and shut pressure tap.

2. Open pressure tap labelled "OUTLET" (half turn) and connect manometer. Verify gas pressures are within range while unit is running on HI and LO. Release manometer and shut pressure tap. **Contact your dealer if proper pressures cannot be achieved.**

**Note** - The fireplace must be isolated from the gas supply piping system by closing its equipment shut-off valve during any pressure testing of that system at test pressures in excess of 1/2 psi (3.5 kPa).

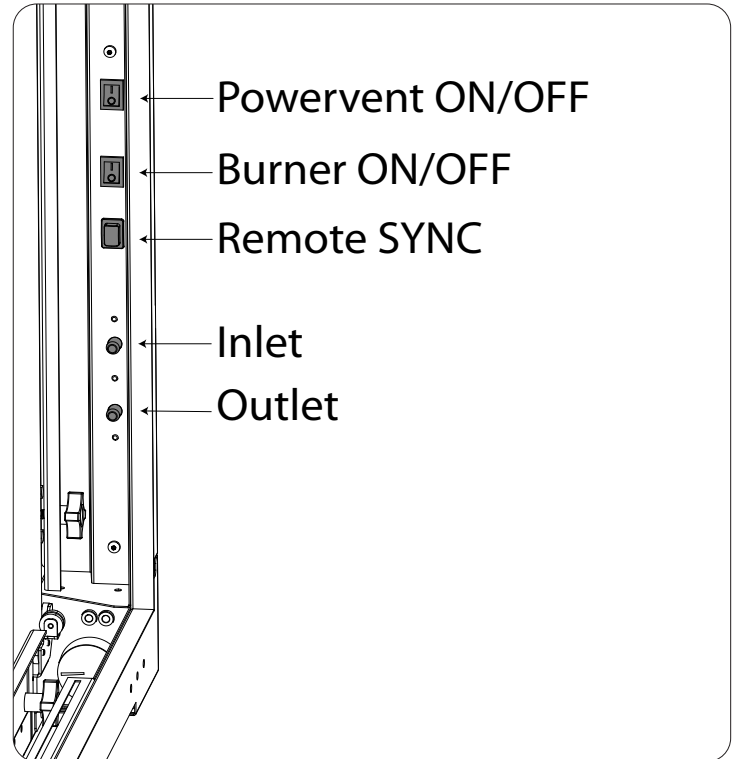

Natural Gas	
Main Orifice	#29
Manifold Pressure	3.5" W.C. (0.89 KPa)
Min. Manifold Pressure	1.6" W.C. (0.39 KPa)
Max Supply Pressure	7.0" W.C. (1.74 KPa)
Min. Supply Pressure	4.5" W.C. (1.12 KPa)
U33I	45,000 BTU/hr (13.2KW/hr)

Propane	
Main Orifice	#45
Manifold Pressure	10.0" W.C. (2.49 KPa)
Min. Manifold Pressure	6.4" W.C. (1.59 KPa)
Max Supply Pressure	11.0" W.C. (2.74 KPa)
Min. Supply Pressure	10.4" W.C. (2.59 KPa)
U33I	45,000 BTU/hr (13.2KW/hr)

## Screen Removal

1. The Screen is secured to the unit with two hooks towards the top of the screen.
2. Lift up the frame of the screen and pull the screen towards you.
3. When the top of the frame has past the front of the unit lift the frame up and out to clear the locating tab at the bottom of the screen.

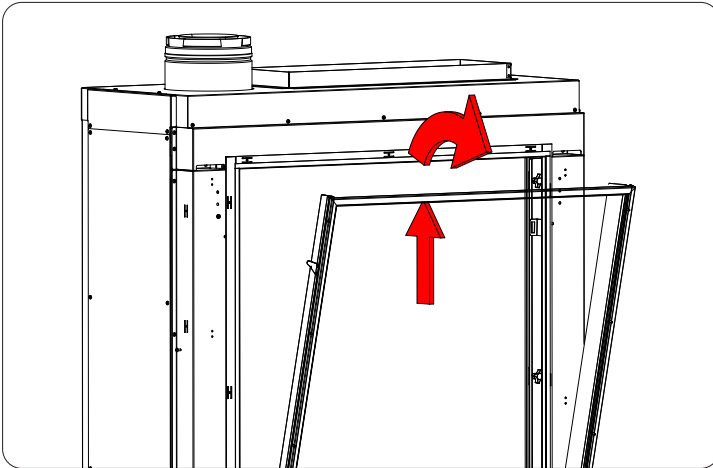

## Screen Install

1. Rotate screen hooks on the inside of the cabinet into place. Do this on both sides.

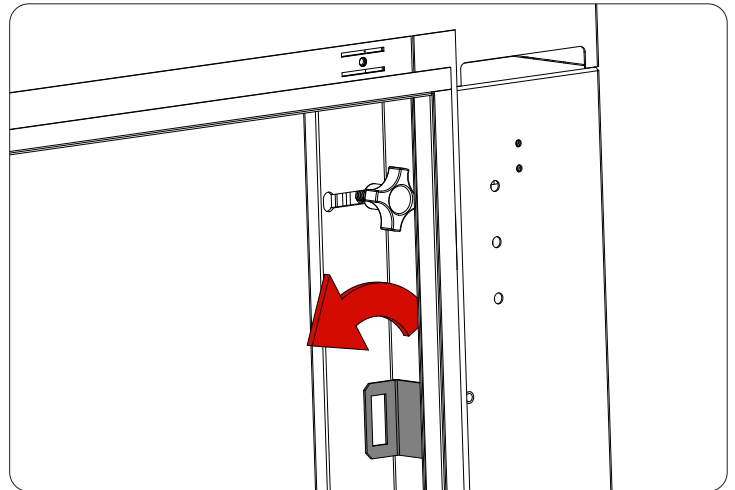

2. Locate the bottom of the screen into the open slot in the bottom of the cabinet.

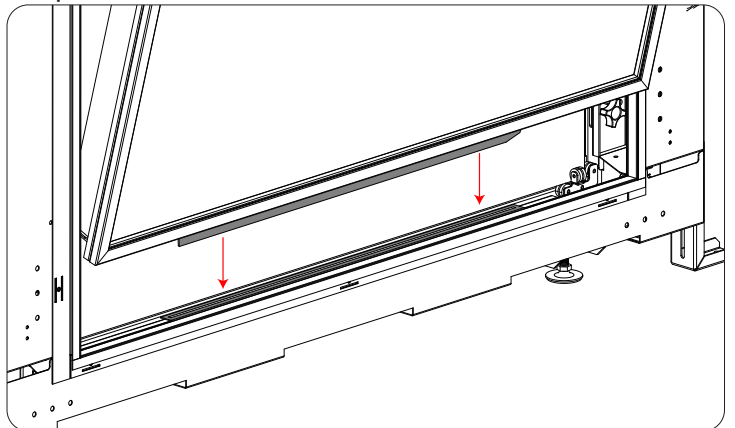

3. Rotate the top of the screen back towards the fireplace until the screen is hooked into place.

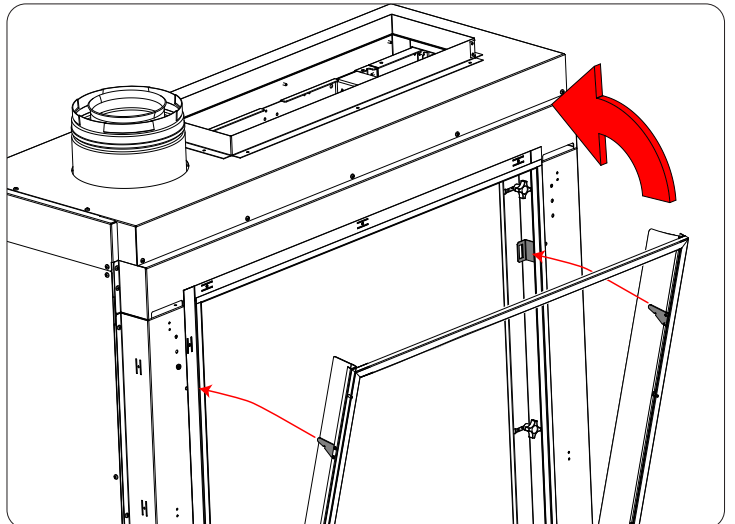

#### Glass Barrier

**YOU WILL NEED SUCTION CUPS TO REMOVE THE GLASS FROM THIS UNIT.**

Initial paint curing of the appliance can leave a slight film on the glass. The glass will need cleaning after the fireplace has cooled off from the first burn and about two weeks after first burn.

Use a mild glass cleaner and a soft cloth. Depending on the amount of use, the glass should require cleaning no more than two or three times a season.

**CAUTION:** Abrasive cleaners will damage the glass and painted surfaces. **Do not clean the glass when it is hot.**

The Glass is heavy and should be handled with care. When handling, make sure to place down gently onto a soft surface when servicing the unit. Breaking the Glass will result in a dangerous mess. Use a shop vacuum to clean if a break occurs. All glass should be handled with quality suction cups such as 50-4164. Two suction cups must be used for larger glass segments. If the Glass Needs to be Replaced. The Replacement can only be purchased from an Urbana Dealer. (PN 50-4404) Failure to do so may result in an unsafe unit and a voided warranty.

#### Glass Removal

**YOU WILL NEED SUCTION CUPS TO REMOVE THE GLASS FROM THIS UNIT.**

**1.** Attach 2 suction cups to the glass as shown in the image below.

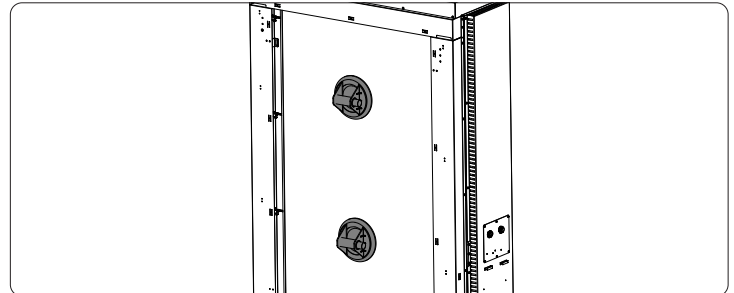

**2.** Rotate the screen catches out of the way. (You may need to loosen the wing nuts to help rotate the catches.)

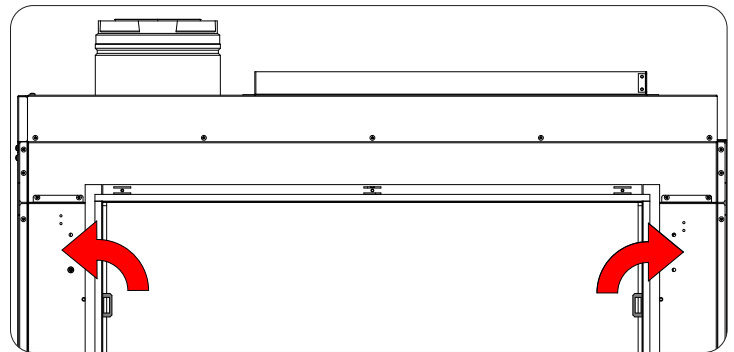

**3.** Unscrew hand knobs on the glass clamps, these are situated around each edge of the glass.

**4.** Slide glass clamps out of the way of the glass.

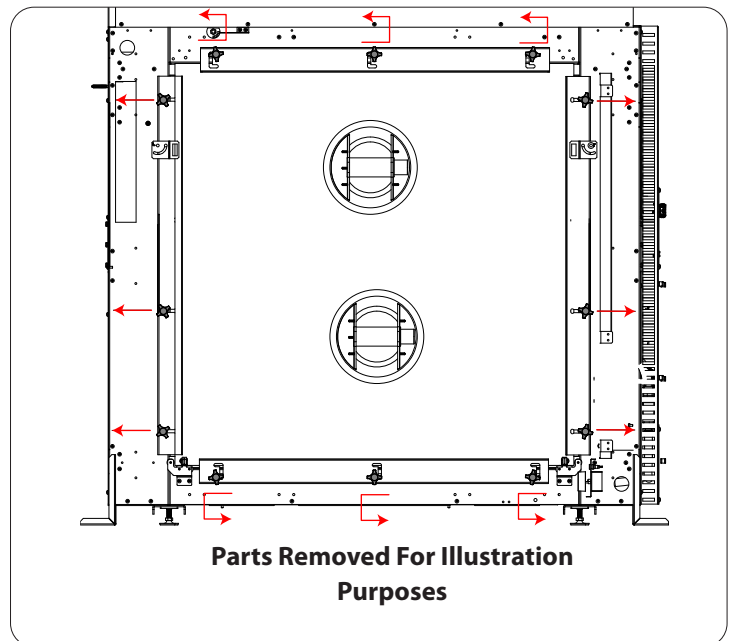

## Glass Installation

The Installation of the glass barrier is integral to the safe and optimal running of this fireplace, The glass must be securely fastened to the fireplace, before the unit is turned on. The Unit has Clamps situated around the outside of the firebox that hold the Glass in place.

The Clamps are secured in place with 12 Hand knobs. All hand knobs must be done up tightly. to ensure a good seal between the glass and the firebox is made. to install the glass follow the steps below.

1. Ensuring that the suction cups are securely engaged, lift up the glass and lead the top edge of the glass inside the cabinet. Make sure not to hit the glass clamps.

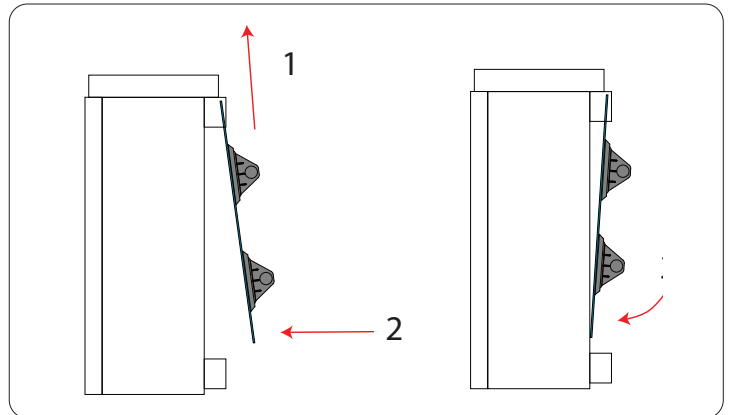

2. Lift the glass high enough so the bottom of the glass will pass over the edge of the cabinet, then swing the glass towards the unit.

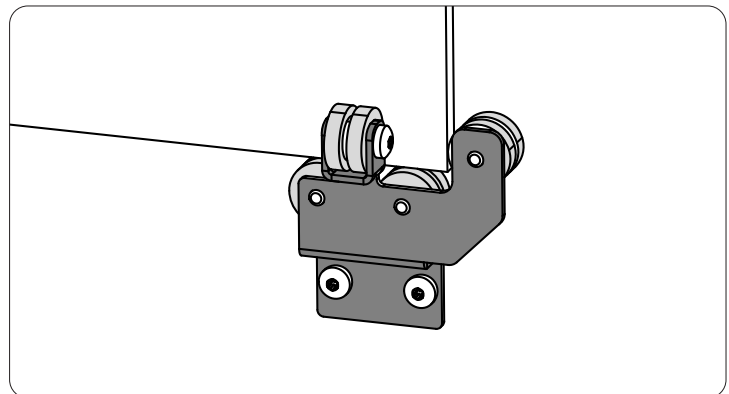

3. The glass sits on rubber bumpers that hold each corner of the glass. Lift the glass up and over the front of the clamp, then ensure that the glass sits flush to the firebox and against the braided gasket.

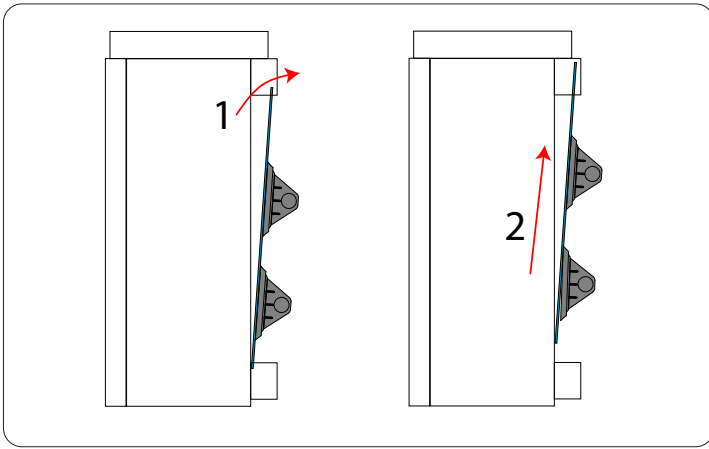

5. With the clamps undone, pull the top of glass towards you.

6. Angled towards you. Lift up the glass up into the cabinet pocket at the top of the unit. Make sure the bottom edge clears the edge of the cabinet.

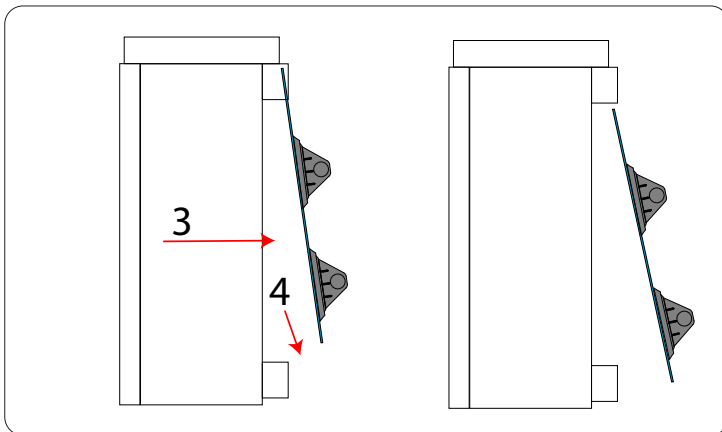

7. Move the glass down and out so the top edge clears the cabinet.

8. Set the glass down carefully, making sure to protect vulnerable corners.

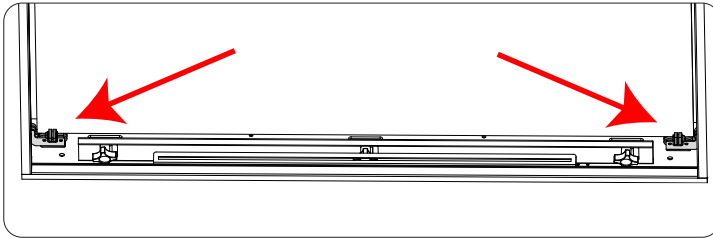

4. After lowering the glass into the bumpers. Position the glass clamps over the glass. Tighten all of the hand knobs. **IT IS VITAL THAT THE GLASS IS SEALED PROPERLY MAKE SURE THE HAND KNOBS ARE AS TIGHT AS POSSIBLE.**

If the clamps are loose this can affect flame appearance, and the safety of the unit.

### Remote Syncing

To Sync the Remote to the unit.

1. Remove the screen (See page 13)
2. On the right hand side, locate the reset switch panel mounted on the inner fireplace cabinet.
3. Press the bottom button that says SYNC. You will hear 3 beeps from the IFC.
4. On hearing the 3 beeps, press the ON/OFF key on your remote; you will hear 3 more beeps to acknowledge successful remote syncing.
5. Press the ON/OFF key again to turn off the remote. The remote is now ready to use.

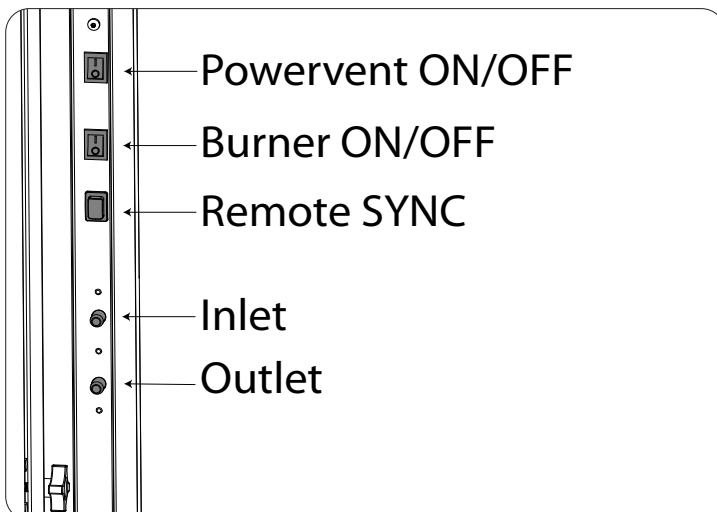

### Air Shutter (Venturi)

The air shutter plays a very important role in flame appearance and combustion quality. The shutter adjusts how much air gets mixed with the gas before it ignites. The air shutter is set from the factory, however it may be necessary to adjust depending on your elevation or vent run.

1. Remove screen (see page 13).
2. Remove Glass (see Page 14)
3. Remove burner Tray Access panel

To add more primary air, (cleaner bluer flame) rotate knob clockwise.

To close off primary air: Rotate knob anti clockwise (yellow and tall flame)

NOTE: Too little primary air will create excessive sooting and will require more cleaning of the glass.

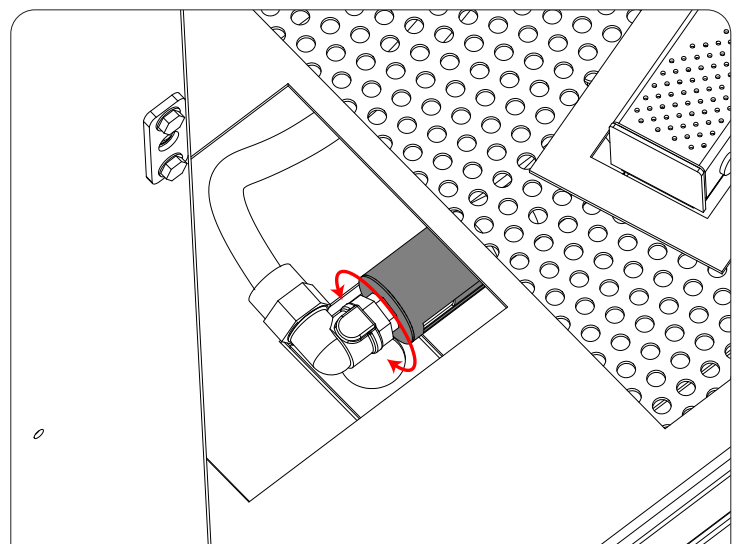
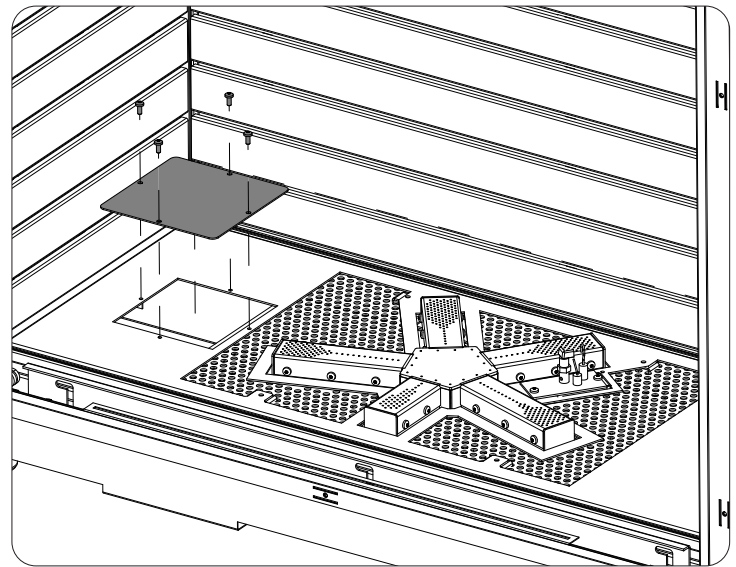



## Electrical, IFC & Valve Access

The valve, IFC, and all electrical connections may need to be accessed for installation, service or maintenance. To access these items, follow these steps.

1. Remove screen (see page 13).
2. Remove glass (see page 14).
3. Remove Right Hand Side Liner (see page 19)
4. Unscrew control panel access panel to access components.

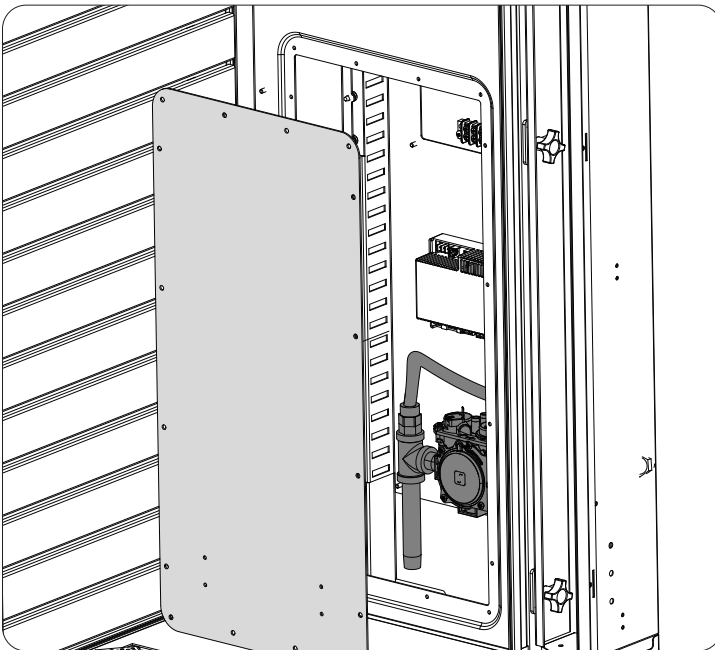

**Caution:** Label all wires prior to disconnection when servicing controls. Wiring errors can cause improper and dangerous operation. Verify operation after servicing.

### WARNING

Failure to reposition parts in accordance with this manual, or failure to use only parts specifically approved with this appliance may result in property damage or personal injury.

## Pilot Light

The pilot flame should cover 1/4" to 1/2" (7 to 13mm) of the flame sensor (see photo). The pilot flow adjustment is set to maximum from the factory and should not need adjustment. However, should the need arise, adjust pilot flame as follows:

1. Remove screen (see page 13).
2. Remove glass (see page 14)
3. Remove right side liner (See Page 19)
4. Locate the pilot adjustment screw on the valve (see below).
5. Turn the adjustment screw to alter the pilot gas flow as needed.

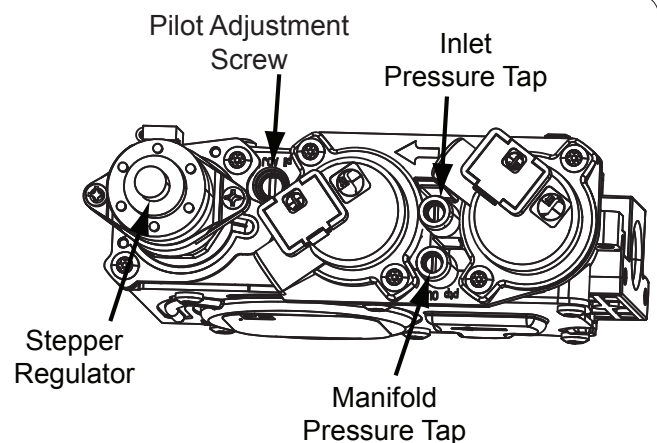
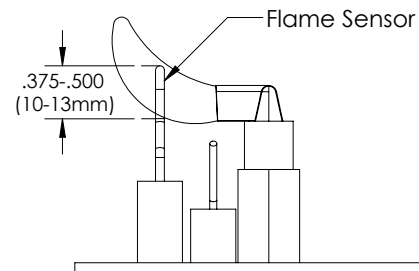

### Baffle Install

The unit comes with a baffle to hide the top of the firebox. The baffle is hooked onto the top of the firebox and does not require fasteners.

1. Remove screen (see page 13)
2. Remove Glass (see Page 14)
3. With the hooks facing the back of the unit, position the baffle in the centre of the unit.
4. Lift baffle up to the top of the firebox and slide it forwards towards the rear of the unit. The baffle should now be hooked in place.

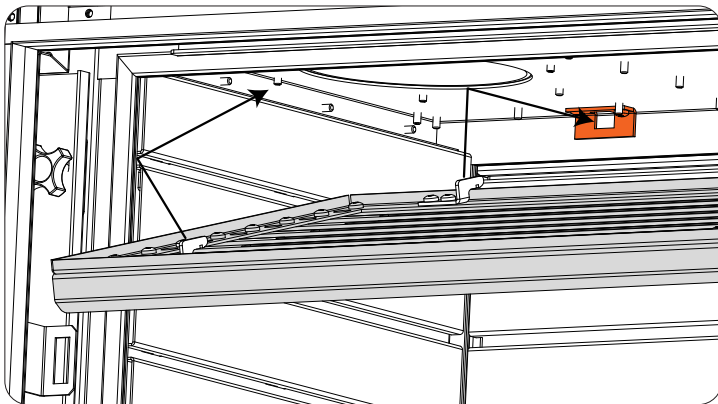

### Baffle Removal

1. Push baffle up and pull towards yourself.
2. Then lower baffle down and out of the firebox.

### Burner Removal

The burner may need to be replaced if defective or damaged, It also must be removed for fuel conversion. Replace burner as follows:

1. Remove screens (see page 13).
2. Remove glass (see page 14).

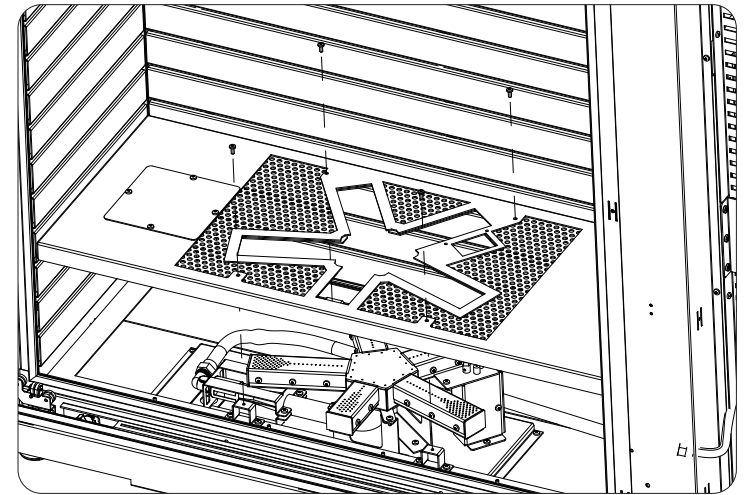

3. Remove burner media.
4. Using T20 driver bit remove screws holding burner tray in place.
5. Lift out media tray.

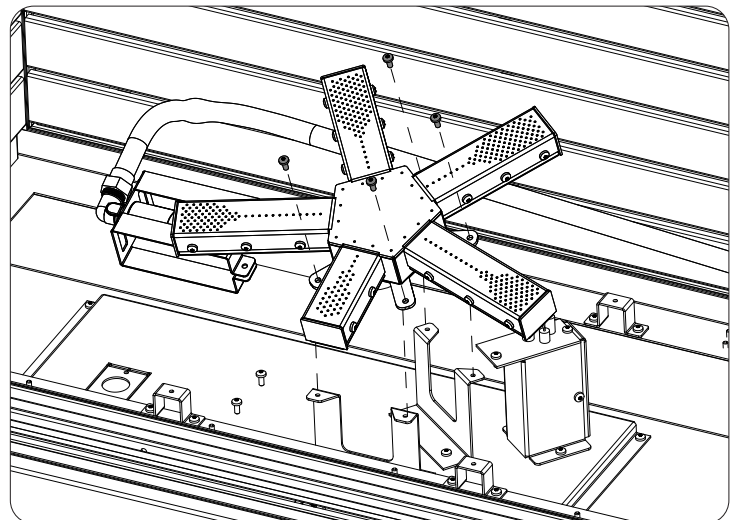

6. Unscrew the 4 screws on the burner mounting plate.
7. Unscrew the two screws securing the orifice clamp to the burner tube.
8. Bend up the orifice clamp to remove the burner assembly.
9. Reverse procedure to install burner.

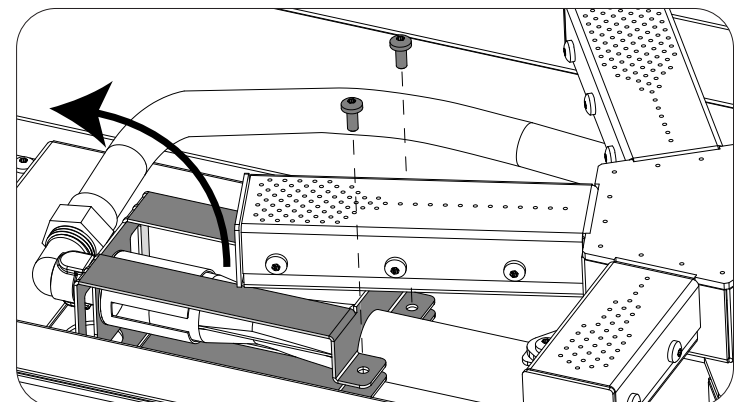

## Removing Horizontal Liners

The horizontal liners that is standard in your U33T has removable panels.

**You will need to remove the right hand side liner to access the valve and IFC**

1. The side liners have 3 removable pieces the Rear liner has 4 removable panels.
2. The below image shows which panels are removable.

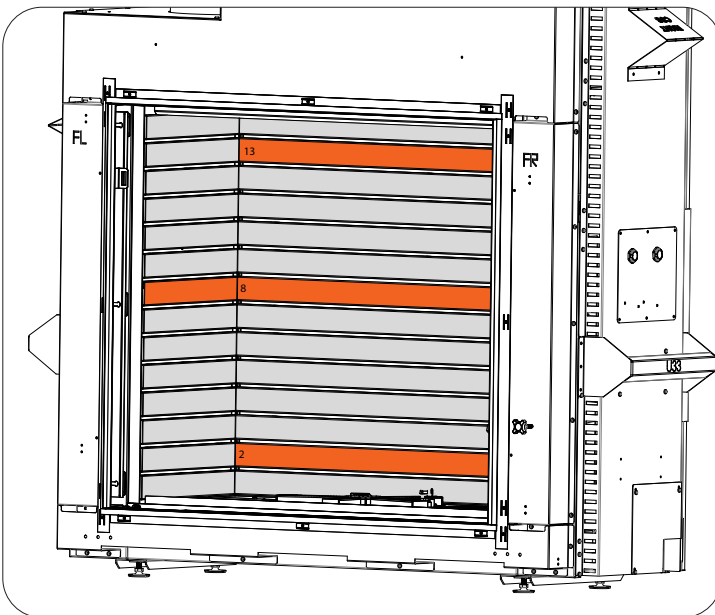

**The right hand side panel not shown in this image, also has the same removable panels as the opposite side liner.**

3. The removable liners are held on with hooks. To remove, locate the correct panel, slide the liner up and then remove from firebox. A screwdriver may be required to gently slide the panel up.

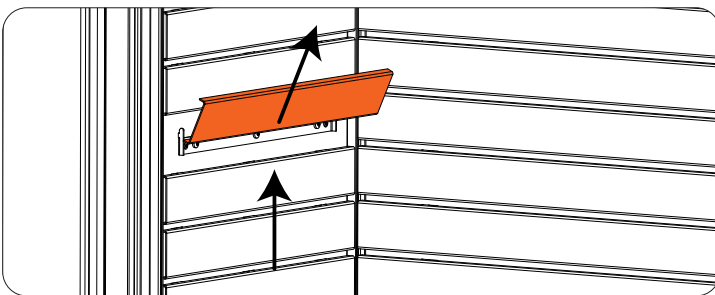

4. Behind the removable panel you will see T20 fasteners, remove these screw to release the liner from the firebox. You will need to do this at each removable panel location.

5. To remove the side liners from the firebox you will need to remove the Baffle (see page 18). The side liners are a 1 piece construction and can be lifted out.

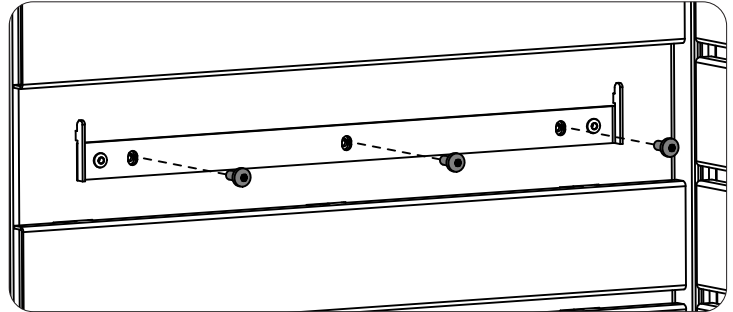

6. The rear liner is constructed from 2 pieces an upper and a lower. After removing the individual removable panels, remove the T20 screws holding in the top liner panel. Then top panel can then be removed.

7. Repeat removal of screws for the lower panel.

8. Reverse the process for installation of the horizontal panel.

#### Orifice change (Fuel Conversion)

When converting the unit to LP you will need to follow the burner removal instructions

1. Using a 1/2" wrench unscrew the orifice
2. Replace the orifice with the LP orifice provided with your unit.
3. Reverse burner removal instructions.
4. Open air shutter to adjust for different fuel.

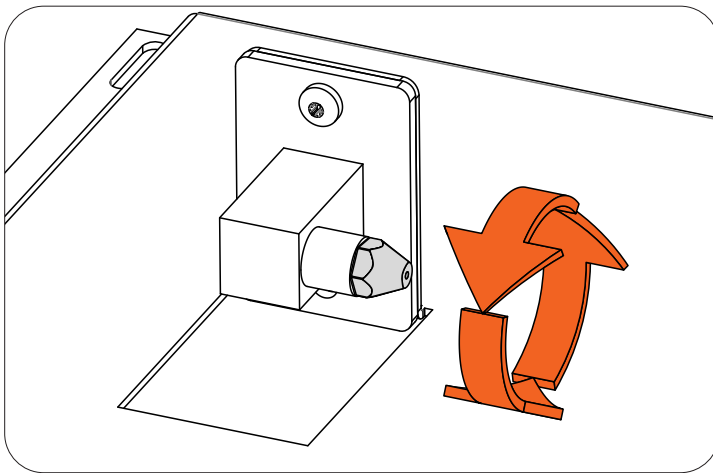

#### Fuel Conversion:

**TO BE INSTALLED BY A QUALIFIED SERVICE AGENCY ONLY**

Please read and understand these instructions before installing.

**Warning: This conversion kit shall be installed by a qualified service agency in accordance with the manufacturer's instructions and all applicable codes and requirements of the authority having jurisdiction. If the information in these instructions is not followed exactly, a fire, explosion or production of carbon monoxide may result causing property damage, personal injury or loss of life. The qualified service agency is responsible for the proper installation of this kit. The installation is not proper or complete until the operation of the converted appliance is checked as specified in the manufacturer's instructions supplied with the kit.**

#### Kit Parts List for U33T:

- 1 - LP Stepper Motor w/ Hardware
- 1 - Burner Orifices (LP: #45)
- 1 - Pilot Orifice (NG: 0.2) or (LP: 0.14)
- 2 - Conversion Labels [included with unit]

Carefully inspect all parts supplied with this conversion kit. If any parts have been damaged or are missing, contact your dealer, distributor or courier company to have them replaced before starting this installation.

**1. Disconnect the gas supply completely as well as any electrical power source before proceeding.**

**2. Remove safety screen, glass, and burner media tray & burner**

**3. Convert the existing burner orifice with the ones provided in this kit using a 1/2 inch socket.**

**4. Convert the existing pilot orifice using a 7/16 inch wrench. Loosen the pilot head, rotate counter clockwise and fully remove. Remove the existing orifice and replace with the one supplied in the kit. Re-install the pilot head and tighten back to its original position.**



To Convert the gas valve:

**5. Remove right hand side liner (see Page19)**

**6. Remove control panel cover.**

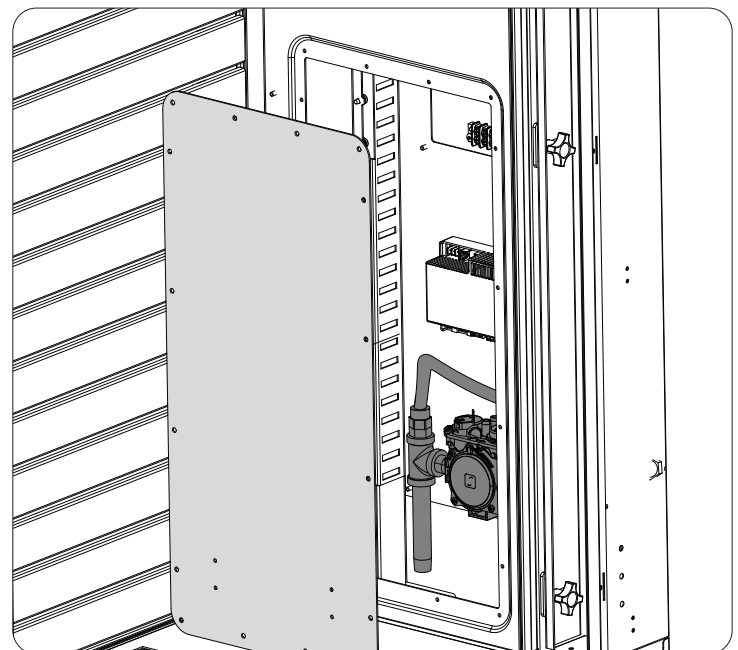

7. a) Remove the existing stepper motor using a T-20 screwdriver.
- b) Remove the rubber diaphragm and spring within; do not reuse.
- c) Install the new stepper motor with integrated diaphragm assembly using longer hardware.
- d) Plug new motor into existing wiring harness.

8. Adjust the burner shutter cap to the proper setting. Roughly an opening of 1/4" is a good place to start. Increase the amount of air required as necessary. The media tray has an access panel to allow for adjustment of the air shutter with the logs in place.

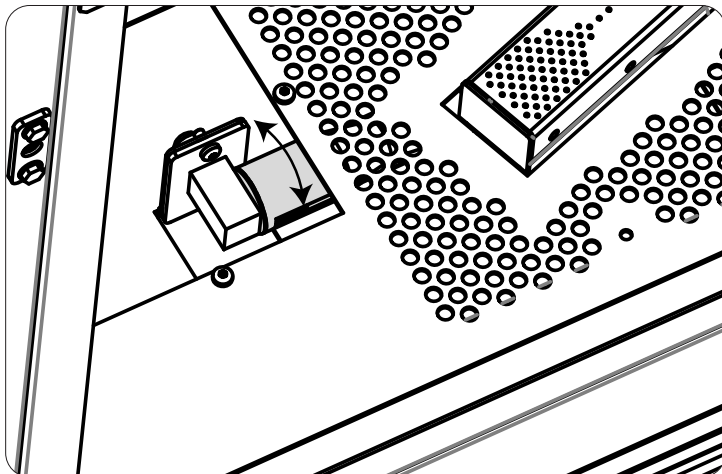

9. Reinstall burners, burner media, logs, and glass
10. Purge any air from gas line and reconnect to unit.
11. Use a small brush and apply a warm soapy water solution to all gas connections. If a gas leak is present, bubbling will occur. Gas leaks can be repaired by using a gas approved pipe thread sealant. **WARNING: NEVER USE AN OPEN FLAME WHEN TESTING FOR GAS LEAKS.**
12. Reconnect electrical power to the unit.
13. Light the pilot and recheck for leaks in the aluminum pilot line. If a leak is evident, contact your Urbana dealer for a pilot line replacement. **WARNING: DO NOT ATTEMPT TO FIX THIS LINE, IT MUST BE REPLACED IF DAMAGED.** The pilot should properly cover the flame sensor. If adjustment is necessary, turn the adjustment screw in the valve clockwise to decrease and counter-clockwise to increase until the correct flame is achieved.
14. Start the main burner and verify full range of adjustment using the UP/DOWN key. Confirm the inlet and manifold gas pressures are within the acceptable range using a manometer ( If this unit has been installed at an altitude higher than 2000ft (610m) it is required to de-rate the unit accordingly. **In the USA:** The appliance may be installed at higher altitudes.

15. Please refer to your American Gas Association guidelines which state: the sea level rated input of Gas Designed Appliances installed at elevations above 2000 (610 m) feet is to be reduced 4% for each 1000 feet (305 m) above sea level. Refer also to local authorities or codes which have jurisdiction in your area regarding the de-rate guidelines.

**In Canada:** When the appliance is installed at elevations above 4500 feet (1372 m), the certified high altitude rating shall be reduced at the rate of 4% for each additional 1000 feet (305 m).

**16. MAKE SURE** that the conversion labels provided are installed on or close to the rating label to signify that the unit has been converted to a different fuel type.

## Maintenance and Service

Run through the procedures in this section to ensure the fireplace system is clean and working properly at least once a year.

Inspect the following:

- Check the burner to see if all the ports are clear and clean.
- Check the pilot to make sure it is not blocked by anything. (The pilot flame should be blue with little or no yellow tips.)
- Clean glass (see page 14 for removal instructions). Use a soft, lint free cloth with a mild glass cleaner to ensure no residue is left behind.

## Burner Maintenance

It is recommended to service this fireplace yearly by a qualified professional.

At this time, the Ceramic logs and media should be removed from the unit and carefully set aside for re-installation.

The media tray should be removed.

Use a vacuum cleaner to remove all Remaining media dust around the firebox.

Remove the Burner From the Mounting Stands and carefully visually inspect the burner for cracks. Once satisfied that the burner is intact, and undamaged install the burner and replace the media as per the instructions found on page 40.

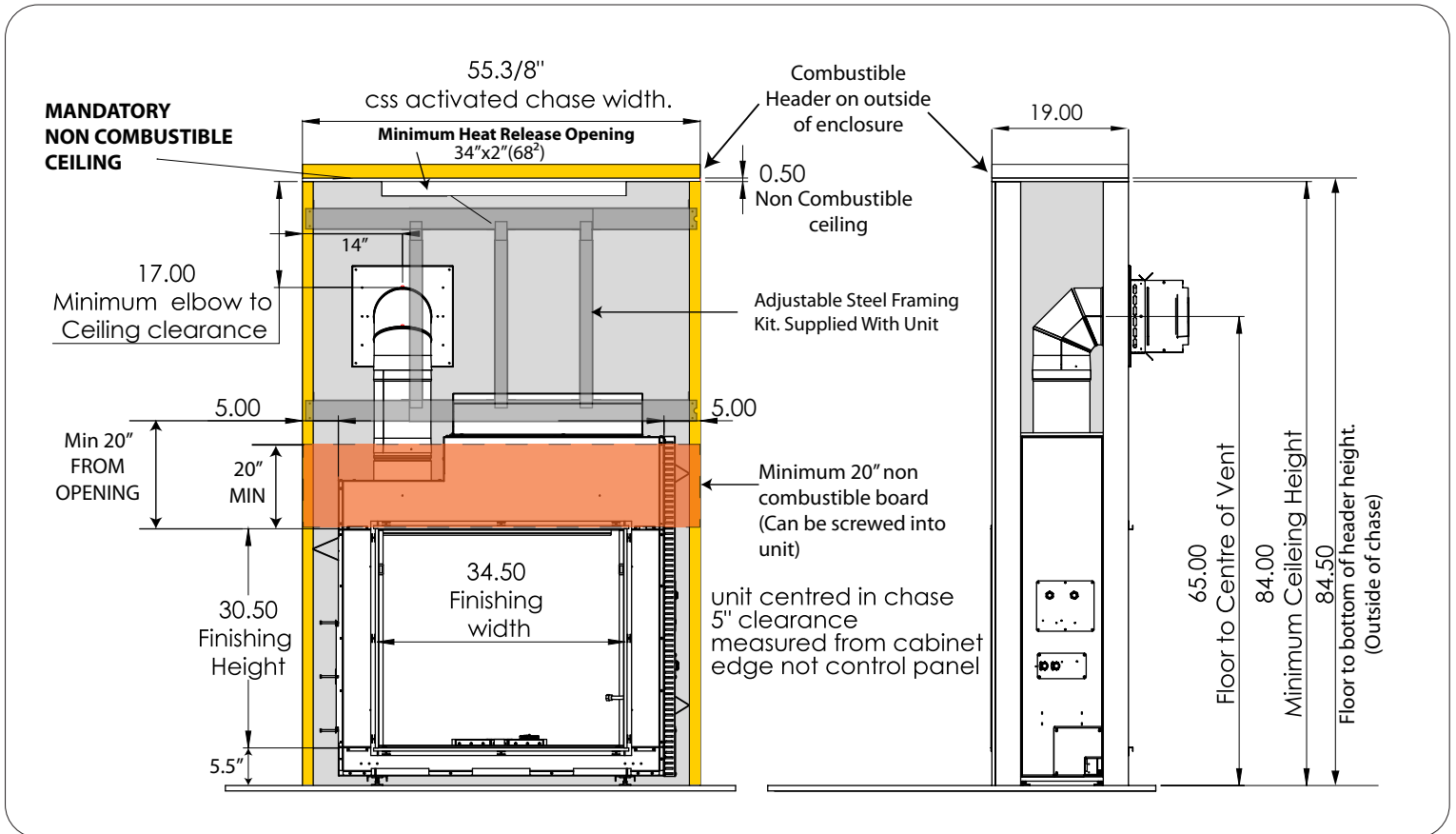

**The U33 can be used with or without a cool surface system. When activated the cool surface system allows for the minimum chase width to be reduced.**

**NON CSS minimum width 70.5"  
CSS activated minimum width 55 3/8"  
Plan your Installation accordingly.**

**NOTES:**

- An opening of 68" is required. for use with the CSS. A typical front opening size of 34"x2"
- **Non combustible ceiling is required.**
- Chase may be framed beyond minimum framing for taller ceilings, overhangs etc.
- Non combustible board is required 20"(min) above the opening of the fireplace. (Construction maybe simpler to run the non combustible board from the top of the opening to the ceiling.)
- Chase cannot be open to joists or rafters above.
- Chase heat release(s) must be at least 60" (152 cm) away from the nearest fire sprinkler head.
- The fireplace is not load bearing so the chase must be constructed to fully support finishing materials.
- **A larger chase will always breathe more efficiently maintaining cooler surface temperatures.**
- No intake air gap is required.
- U33I is not permitted for a recess in the chase.
- Steel Stud To be positioned where needed to support the facing material. Facing material can be attached to the steel stud.

## Valance

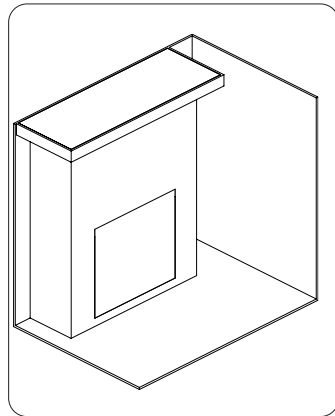
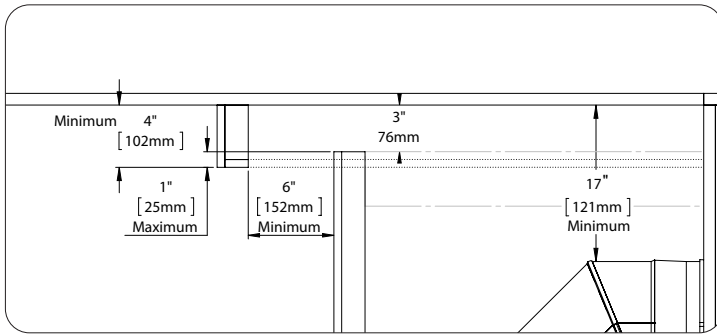

A valance may be desired to accentuate or hide the outlet. This is an optional decorative feature that covers up the CSS outlet gap. Minimum opening and valance dimensions must be followed to ensure safe heat dissipation. Combustible material is acceptable when constructing the valance. It is acceptable to wrap the

valance around the three sides of a built out chase.

## False Ceiling

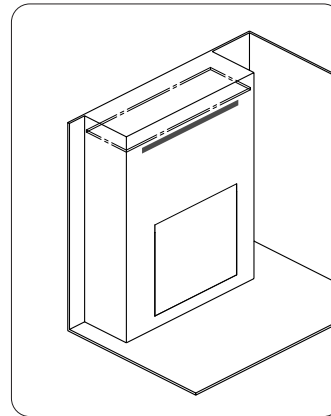
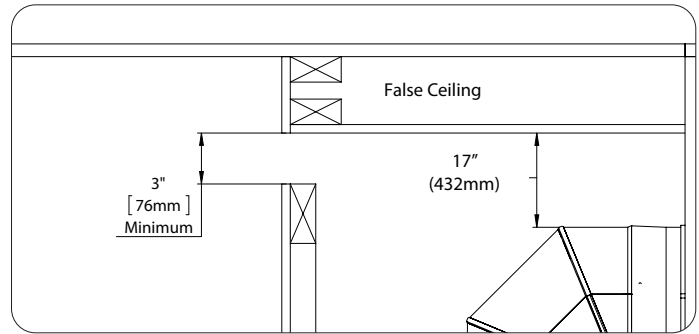

If your ceiling dimension is greater than the minimum You may want the heat discharge lower on the wall. To do this a false ceiling is required to properly evacuate the heat from the chase.

## Side Discharge

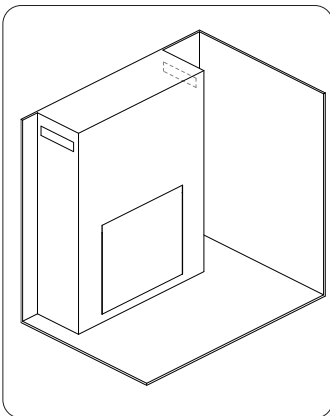
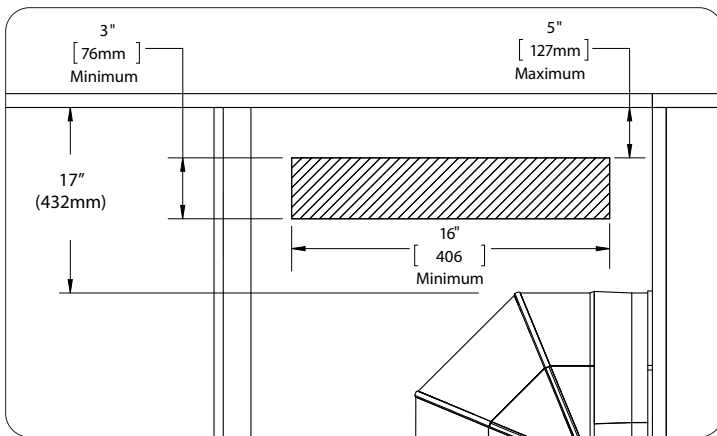

Construct the framing in a way that provides two gaps, one on each side of the chase as shown in. Each gap should be a minimum of 21 inch (533mm) by 3 inch (76mm). It is essential that these dimensions are followed and not to deviated from them when using combustible materials inside the chase.

## Open Chase (built-out installations) -

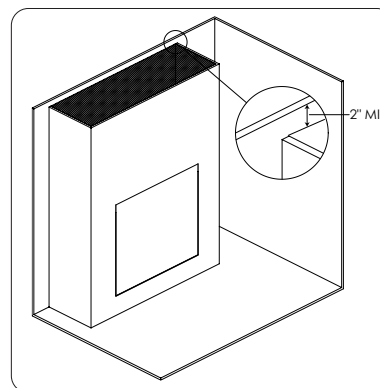
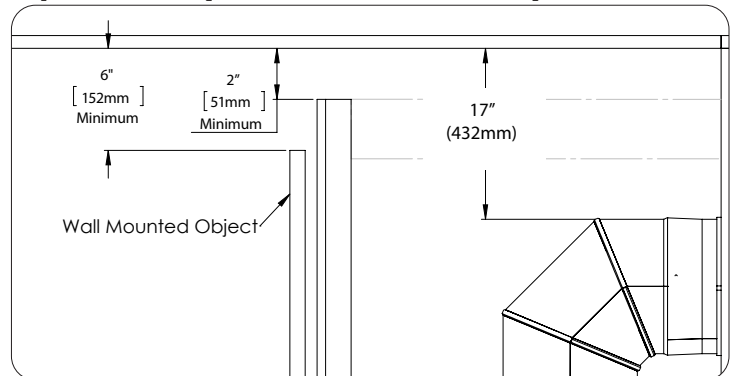

This could be considered the most discreet option The chase must be constructed in a way that stops short of the ceiling, leaving it totally vented above. Minimum framing dimensions must be followed when constructing this option and not to deviated from them when using

combustible materials. Consider a Valance to work in conjunction with this option.

#### Activating CSS

The U33 comes from the Factory in NON CSS configuration. to convert your unit to CSS Ready you need to.

1. Attach the Right and Left CSS standoffs to your unit they are marked L CSS & R CSS Use the screws provided.

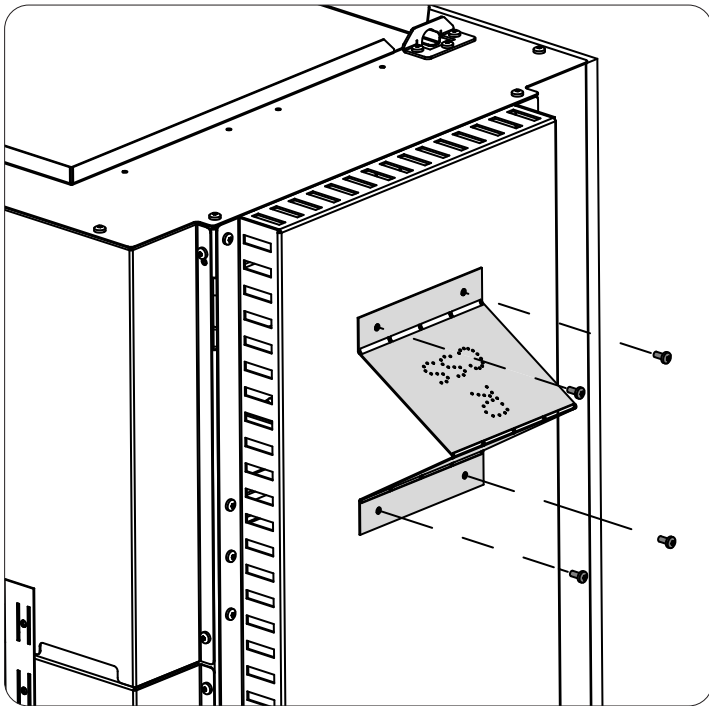

2. remove the cabinet top door and the pivots holding the door in place.

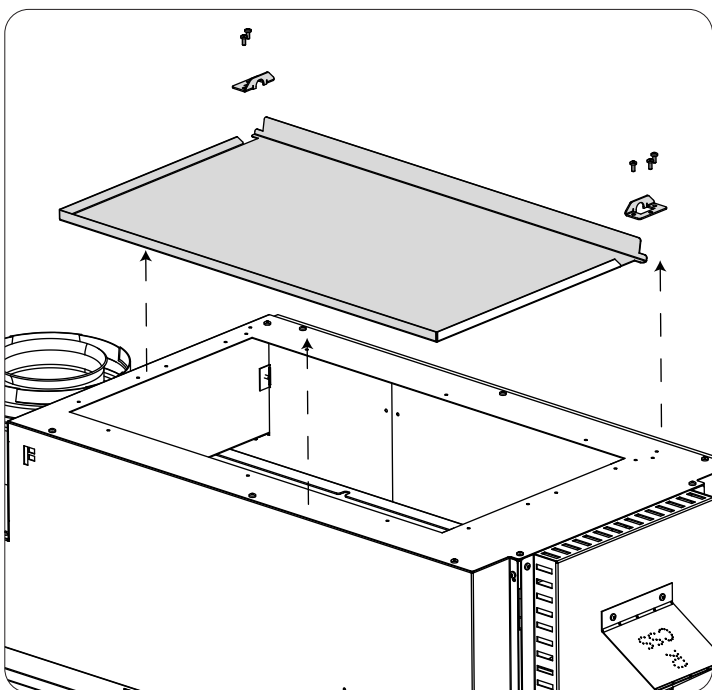

3. Attach the heat shield to the top of the cabinet. face the heat shield to the wall you will have the opening (This is relevant when the unit has been converted to double sided installation).

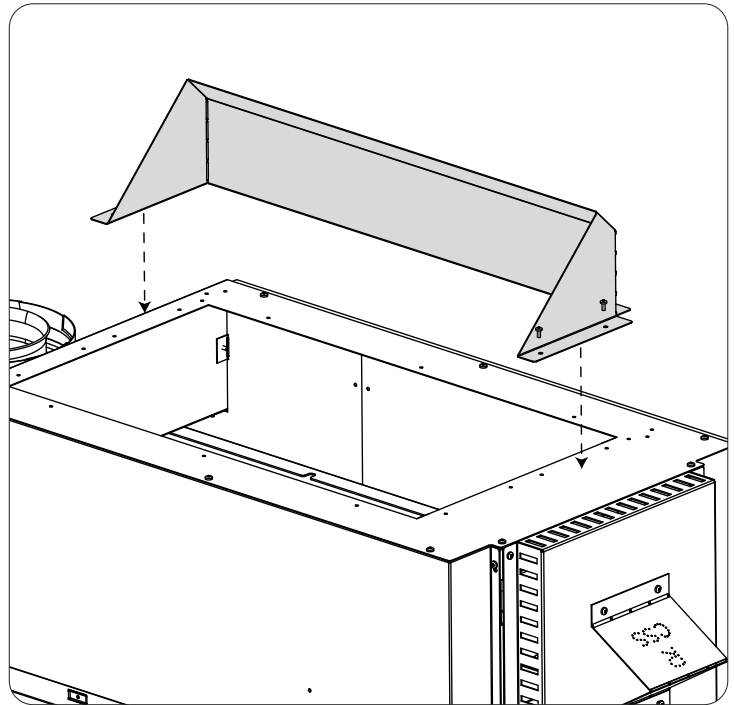

4. the unit is now in CSS mode and can be installed into the chase.

#### Non Combustible Framing Kit

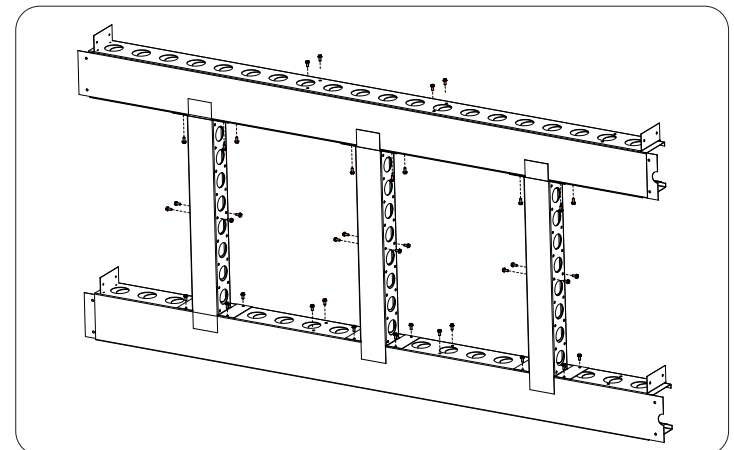

The unit comes with a non-combustible framing kit that should be installed above the unit. The kit can be installed at a minimum of 20 inches above the opening and must not block the heat opening at the top of the chase.

The kit's height and width are adjustable, ranging from 52 inches wide by 25 inches tall to 96 inches wide by 39 inches tall. The fully extended dimensions allow for construction beyond the minimum framing specifications. Use parts of the kit as and where required. Not all pieces are necessary for every installation.

The framing kit includes self-tapping screws for installing the vertical studs where desired. Additional framing kits can be purchased if needed. (50-4502) For the U33I-ST & U33I-TST models, a framing kit is included for each side of the installation.



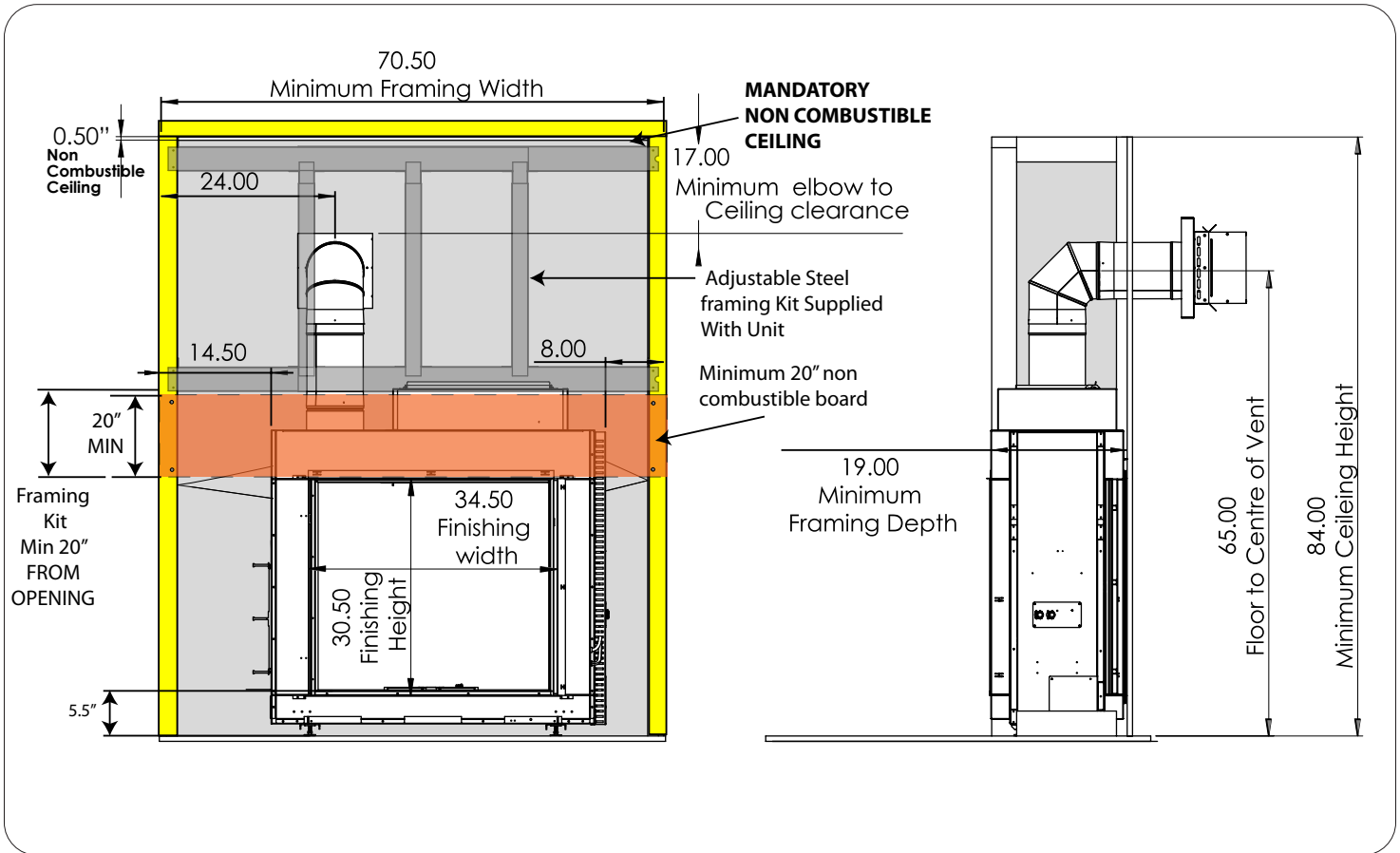

## Double Sided Minimum Framing Clearances

The above dimensions represent the minimum size required for the safe operation of the unit. Please note that these dimensions mean that the unit would not be centred within the chase.

To centre the unit within the chase, an additional 5" width on the right hand side would be required.

This brings the minimum width of the chase to 75.5"

### NOTES:

- **Non combustible ceiling is required.**
- Chase may be framed beyond minimum framing for taller ceilings, overhangs etc.
- Non combustible board is required 20"(min) above the opening of the fireplace. (Construction maybe simpler to run the non combustible board from the top of the opening to the ceiling.)
- Chase cannot be open to joists or rafters above.
- The fireplace is not load bearing so the chase must be constructed to fully support finishing materials.
- **A larger chase will always breathe more efficiently maintaining cooler surface temperatures.**
- No intake air gap is required.
- U33I is not permitted for a recess in the chase.
- Steel Stud To be positioned where needed to support the facing material. Facing material can be attached to the steel stud.

#### Facing Material & Trim

##### NOTES:

- Chase may be framed beyond minimum framing for taller ceilings, overhangs etc.
- Chase cannot be open to joists or rafters above.
- The fireplace is not load bearing so the chase must be constructed to fully support finishing materials.

The unit comes with the clean face trim installed on the unit. They allow up to 1" of facing material. This can be achieved in a few different ways

- Up to 1" facing material can be used if the material is non combustibile rated.
- 1/2" non combustibile board can be used on its own with 1/2" of the trim protruding.
- 1 layer of non combustibile material covered by a layer of combustibile facing material.

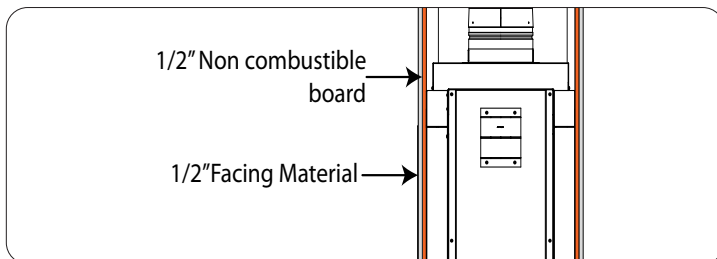

#### Facing Material & Trim

- The unit also ships with a tiling flange that allows for 1/2" drywall or 1/2" tiles to be hidden behind a thin bezel. You can switch out the clean face trim for the tiling edge by unscrewing the T20 Fasteners and replacing the clean face with the trim found in your packaging.

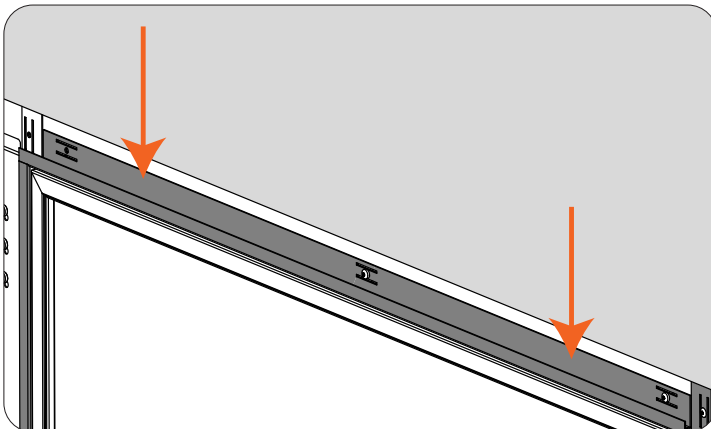

#### Corner Install (CSS ONLY)

These are the minimum allowable framing dimensions required to safely operate the appliance in a corner install

**This Install can only be used with the CSS activated.**

Plan your entire installation before proceeding.

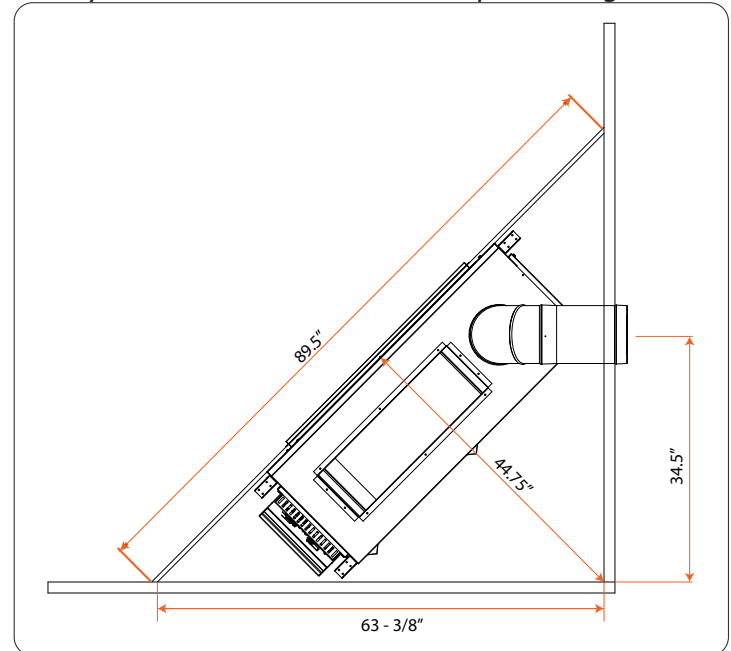

#### Floor Protection

A protective hearth is not required but highly recommended for the longevity of sensitive flooring materials in front of the appliance.

If masonry is to be used, prepare the necessary foundation for the masonry load. When masonry construction is being used, a lintel must be used over top of the appliance to support the added weight.

Consider the height of hearth finish material (stone, brick, etc.) when building a appliance platform. The bottom of the fireplace must be level with finished hearth.

## Outdoor Install:

**CAUTION** – Installation of an indoor gas fireplace with an outdoor exposure is not covered under the (ANSI Z21.88 – CSA 2.22 or ANSI Z21.50 – CSA 2.33) standard(s) used to certify the indoor gas-fired fireplace. The Intertek safety certification will not apply to this installation method. This installation method must be deemed acceptable by the Authority Having Jurisdiction (AHJ) prior to the indoor gas fireplace being installed.

The U33I fireplace may be installed in a covered outdoor area when following the requirements stated below: Fireplace must be installed in a weather proof enclosure while still following all clearance to combustibles as outlined in the fireplace's manual.

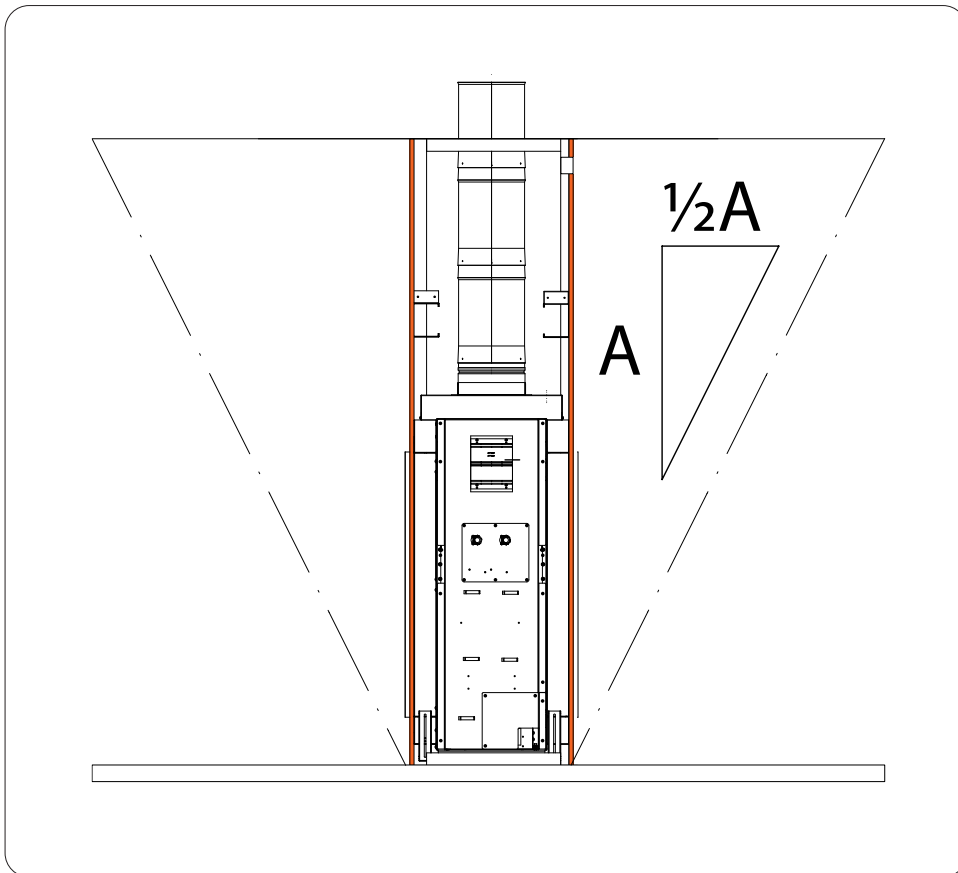

**Outdoor Statements apply to both Single Sided and Double sided install. (Double sided install shown above)**

The fireplace cannot serve as part of the building's insulation or weatherproofing barrier. The U33I cannot be installed on an outside wall as a see double sided unit. The building must be properly insulated and sealed from the outside prior to installation of the fireplace. The fireplace must be protected by an overhang with a depth that is at least equal to half of its height from the base of the fireplace.

**Example - If the overhang height = 8ft (2.4m) then the required overhang depth must be at least 4ft (1.2m)**

The width of the covered overhang on each side of the fireplace must also be at least equal to half of its height

Example - If the overhang height = 8ft (2.4m) then the overhang must extend at least 4ft (1.2m) past each side of the fireplace opening  
Fireplace has to have a heat release. When the covered overhang is flat with no pitch in front or to the side of the fireplace.

- For models equipped with remote control, neither "Smart Mode" nor Thermostat is permitted for use. The fireplace may not be wired to an external thermostat.
- Any outdoor furnishings must be kept a minimum of 3ft (0.9m) away from the front of the fireplace.
- Electrical and gas connections must follow applicable codes and standards pertaining to outdoor installations.
- Horizontal Power vent must not discharge into the same space shared by the front of the fireplace. Vertical Power Vents are recommended.

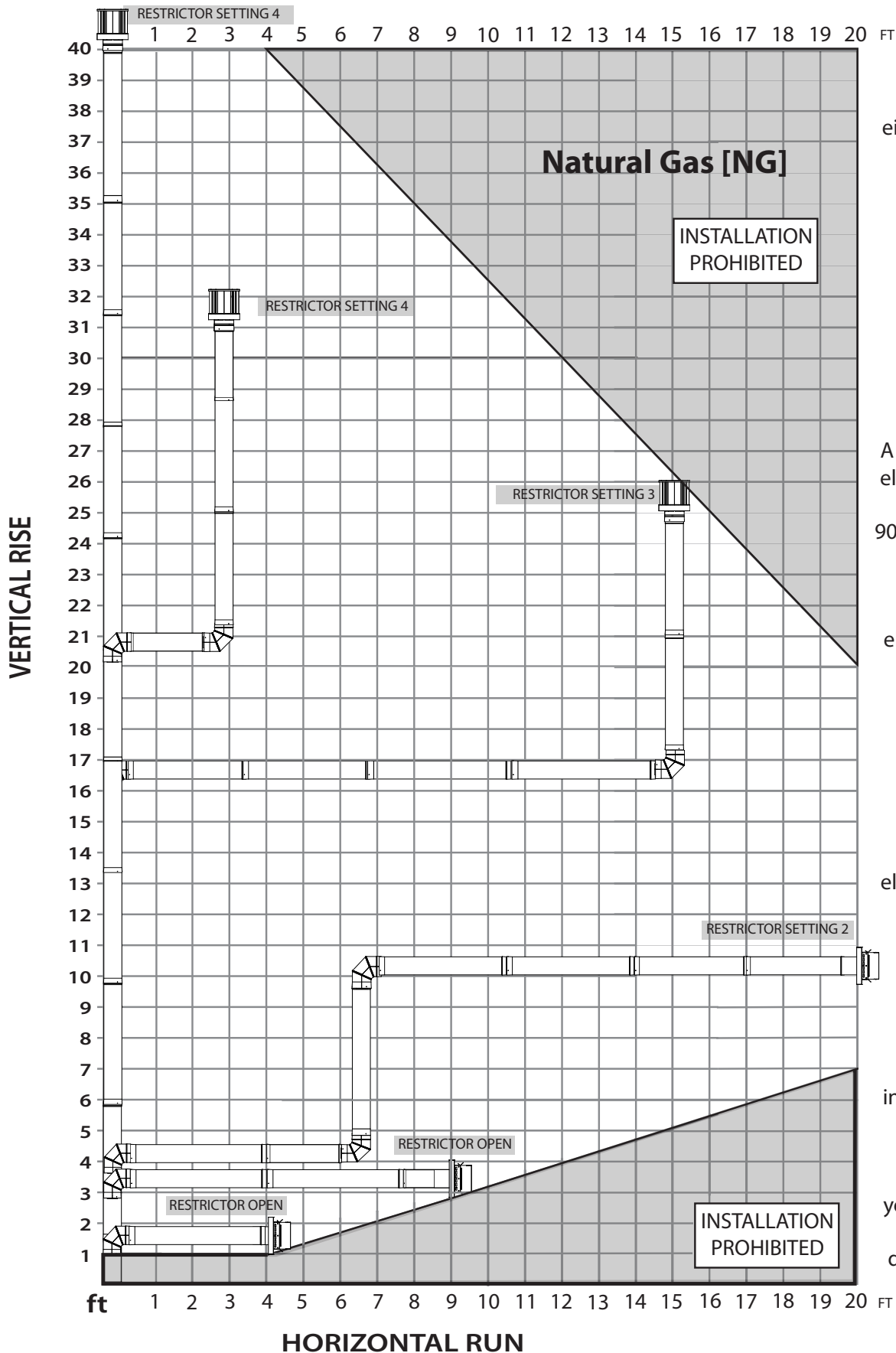

This shows the range of venting options using either vertical or horizontal terminations; any layout that remains within the non shaded area is acceptable. Having the fewest number of elbows is ideal as they restrict air movement. Any combination of rise and run can be used as long as it lays within the non shaded area. A maximum of three (3) 90° elbows or six (6) 45° elbows can be used. 90° elbows in the horizontal plane account for 3 horizontal feet (91.4cm) to your venting run. 45° elbows account for 1½ feet (45.7cm).

**Restrictor Setting:**  
Find the point on the graph where your vent configuration will terminate. Remember to consider elbows in the HORIZONTAL plane account for horizontal distance as stated above. Use the corresponding exhaust restrictor setting indicated on the graph. See the following section in this manual for restrictor details. Your climate and altitude may alter what restrictor is required for your particular application. Adjust as needed for desired flame appearance.

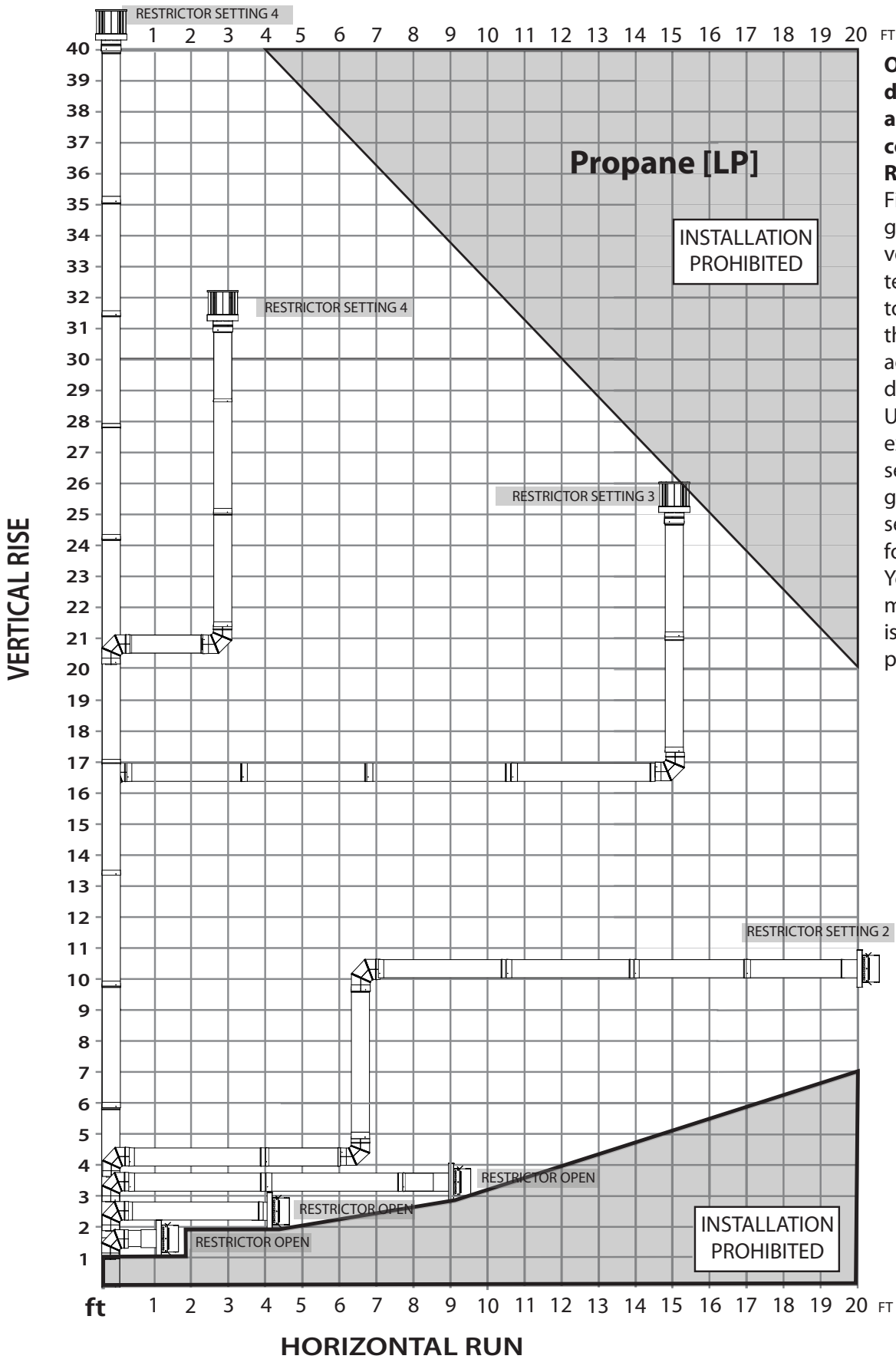

**ONLY use this venting diagram if your appliance has been converted to LP.**

**Restrictor Setting:** Find the point on the graph where your vent configuration will terminate. Remember to consider elbows in the HORIZONTAL plane account for horizontal distance as stated above. Use the corresponding exhaust restrictor setting indicated on the graph. See the following section in this manual for restrictor details. Your climate and altitude may alter what restrictor is required for your particular application.

### Exhaust Restrictor Settings:

The exhaust Restrictor is used on this unit to fine tune and adjust the flame appearance. Climate, altitude, fuel-type, and vent configuration will depict which restrictor setting should be used. Its usage will be dependant on individual installations, but not always required.

Adjustments should be made after running for 15-20 minutes. Consider that the flame will continue to grow as more time passes.

**Note: The air shutter (venturi) can also be adjusted in conjunction with restrictor.**

The restrictor is located at the top left of the glass Above the glass clamp.

To adjust the Restrictor you will need a 7/16" wrench on the nut. It may be easier to access the restrictor nut with the glass hand knob Removed.

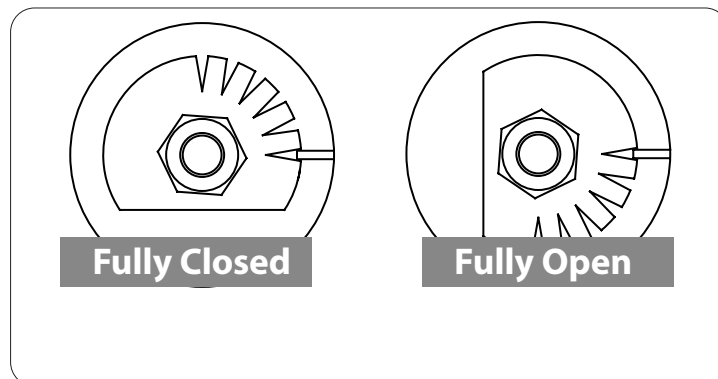
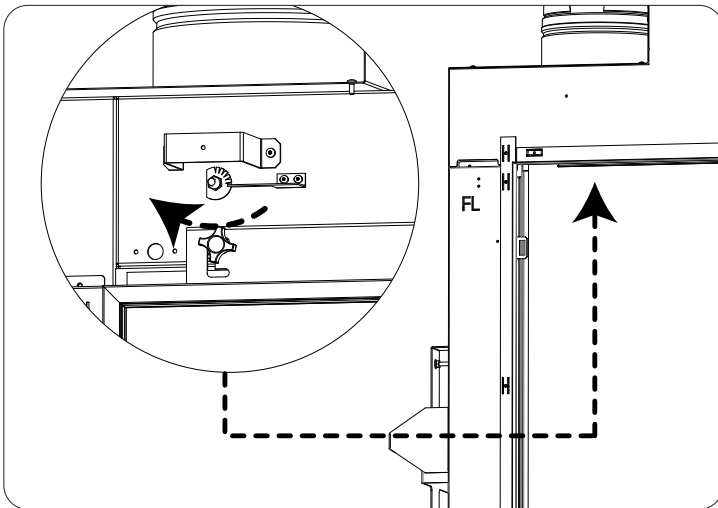

The flat edge of the restrictor disk represents the position of the restrictor.

### Venting Introduction:

Your fireplaces can operate using a natural vent or power vent system (50-3883).

Natural Vent (Rigid): 5" X 8" venting system

Power Vent: 4" x 6 5/8" rigid vent (a reducer will be required) See power vent kit for further information.

Follow the venting instructions for safe and proper operation of the appliance. Deviation from the minimum vertical length can create difficulty in burner start-up and sooting.

Allow several minutes for the flame to stabilize after ignition under extreme vent configurations. It is recommended for vent lengths that pass through unheated spaces (garages, attics, crawl spaces) be insulated to minimize condensation. Use at least 3 screws at each vent connection. Check periodically that the vents are unrestricted, especially the exterior vent cap.

#### Venting Considerations:

1. A power vent system should be considered for extreme weather areas (wind, cold).
2. 36" minimum vertical rise before an elbow does not apply to power vent units.
3. Flex venting is intended for use with simple vent configurations.
4. Use a snorkle termination for more draft (if needed).

**Check periodically that the vents are unrestricted, especially the exterior Venting Termination. Check for obstructions that would impede airflow.**

#### WARNING:

- Follow venting instructions exactly for safe and proper appliance operation.
- Use aluminum tape for all venting connections.
- Risk of fire, explosion, or asphyxiation if improper venting setup.
- Risk of fire, do not allow loose materials or insulation to contact vent pipe. Remove insulation to allow installation of thimble and maintain clearances to combustible materials.

## Allowable Snorkel Installation

A snorkel is permitted for use on installations where additional vertical rise is required on the exterior of the building. Refer to the table for the approved models.

Note - The use of a snorkel does not reduce the minimum required venting or termination clearances.

Note - If there is a soffit above the snorkel termination the supplied heat deflector must be installed. Trimming the length may be required to fit correctly.

Manufacturer	Trade Name	Model #
ICC	EXCELDirect	ST14 ST36
M&G Dura-Vent	Direct Vent Pro	58DVA-SNK14 58DVA-SNK36
Selkirk	DIRECT-TEMP	5DT-ST14

## Mantel Clearance

First determine what mantel height or depth you would like and use the graph to determine the minimum corresponding dimension. Mantel graph dimensions are measured from the opening of the appliance.

It is acceptable to install a combustible mantel over top of the non-combustible board.



## TV Clearances

**Use of the Cool Surface System is highly recommended when mounting a TV or delicate artwork above the appliance.** If the system is not desired, some considerations must be made to ensure above objects are protected from the heat. A mantel is recommended for heat protection.

There is no guarantee that the temperature will not harm the longevity of your TV. Make sure to consult your TV manufactures specifications to find the maximum allowable operating temperature. Since every home and installation is unique, temperatures should be verified at the time of install. A TV should not be installed if temperatures exceed the manufacturers maximum allowable temperature.

### Important Note

While not strictly necessary,

it is **STRONGLY RECOMMENDED** to install a mantel when installing a TV above the Fireplace. Always maintain minimum mantel clearances. (As seen above.)

At a minimum, the mantel depth should be equal to the total depth of the TV including the wall mount.

it is recommended to exceed the minimum mantel depth by 1-2 inches.

## Vent Termination Restrictions & Clearances

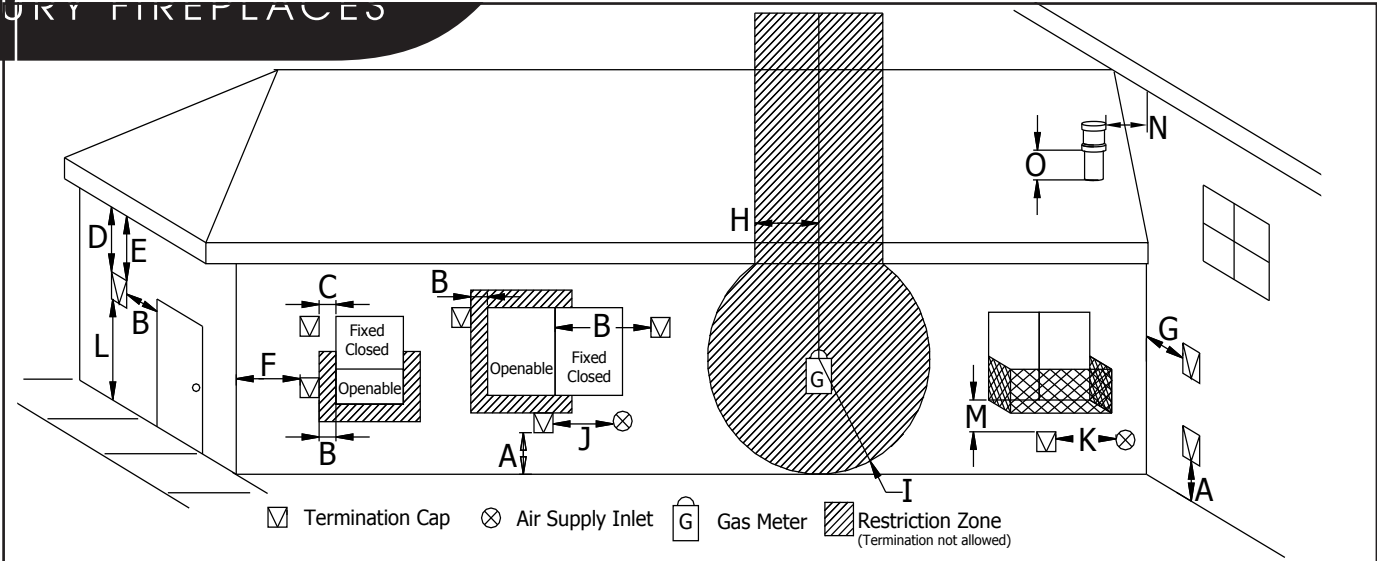

Letter	Canadian Installation <sup>1</sup>	US Installation <sup>2</sup>	Description
A	12 in (30 cm)		Clearance above grade, verandah, porch, deck, or balcony.
B	12 in (30 cm)	9 in (23 cm)	Clearance from window or door that may be opened.
C	12 in (30 cm)*		Clearance from permanently closed window (to prevent condensation).
D	24 in (61 cm)		Vertical clearance to ventilated soffit located above the terminal, within a horizontal distance of 2 ft (60 cm) from center line of terminal.
E	24 in (61 cm)		Clearance to unventilated soffit.
F	12 in (30 cm)*		Clearance to outside corner.
G	4 in (10.2 cm)		Clearance to inside corner.
H	3 ft (91 cm) within a height of 15 ft (4.5 m) above the meter/regulator assembly	3 ft (91 cm) within a height of 15 ft (4.5 m) above the meter/regulator assembly*	Clearance to each side of center line extended above meter/regulator assembly.
I	3 ft (91 cm)	3 ft (91 cm)*	Radial clearance around service regulator vent outlet.
J	12 in (30 cm)	9 in (23 cm)	Clearance to non-mechanical air supply inlet to building, or the combustion air inlet to any other appliance.
K	6 ft (1.83 m)	3 ft (91 cm) above if within 10 ft (3 m) horizontally	Clearance to mechanical air supply inlet.
L	7 ft (2.13 m) <sup>t</sup>	7 ft (2.13 m) <sup>*t</sup>	Clearance above paved sidewalk or paved driveway located on public property.
M	24 in (61 cm) <sup>+</sup>		Clearance under verandah, porch, deck, or balcony.
N	12 in (30 cm)*		Clearance horizontally to any surface (such as an exterior wall) for vertical terminations.
O	12 in (30 cm)		Clearance above roof line for vertical terminations.

<sup>1</sup> In accordance with the current CSA B149, Natural Gas and Propane Installation Code.

<sup>2</sup> In accordance with the current ANSI Z223.1 NFPA 54, National Fuel Gas Code.

\* These numbers are only estimates.

<sup>t</sup> A vent shall not terminate directly above a side walk or paved driveway that is located between two single family dwellings and it serves both dwellings.

<sup>+</sup> Permitted only if verandah, porch, deck, or balcony is fully open on a minimum of two sides beneath the floor.

Clearances are in accordance with local installation codes and the requirements of the gas supplier.



## Vertical Termination

**1.** Check venting clearances and termination restrictions for required clearances to combustibles when passing through ceilings, walls, roofs, enclosures, attic rafters, or other nearby combustible surfaces. Do not pack air spaces with insulation.

**2.** Set the fireplace in the desired location. Drop a plumb bob down from the ceiling to the fireplace flue exit and mark the location where the vent will penetrate the ceiling. Drill a small hole at this point. Next, drop a plumb bob from the roof to the hole and mark the spot where the vent will penetrate the roof. Determine if ceiling joists, roof rafters, or other framing will obstruct the venting system. Relocate the fireplace or offset the venting to avoid cutting load bearing members.

**3.** To determine the length of pipe required, measure room height, ceiling thickness, and vertical rise in an attic or second story. Firestops are required at each floor level beyond the first floor ceiling support/wall thimble cover or cathedral ceiling support box. If an offset is required to avoid obstructions, use a pair of 45 degree elbows. For proper support, use elbow straps with offsets. Use wall straps for long vertical runs. Attic insulation shield is required in attic.

**4.** Measure roof pitch. Select the proper flashing and storm collar and determine the height above the roof (see Table). A non-corrosive pipe material must be used for all exterior pipe lengths. Seal nail heads with silicone.

Roof Pitch	Minimum Height (H)	
	Feet	Meters
Flat to 7/12	1	0.3
Over 7/12 to 8/12	1.5	0.46
Over 8/12 to 9/12	2	0.61
Over 9/12 to 10/12	2.5	0.76
Over 10/12 to 11/12	3.25	0.99
Over 11/12 to 12/12	4	1.22
Over 12/12 to 14/12	5	1.52
Over 14/12 to 16/12	6	1.83
Over 16/12 to 18/12	7	2.13
Over 18/12 to 20/12	7.5	2.29
Over 20/12 to 21/12	8	2.44

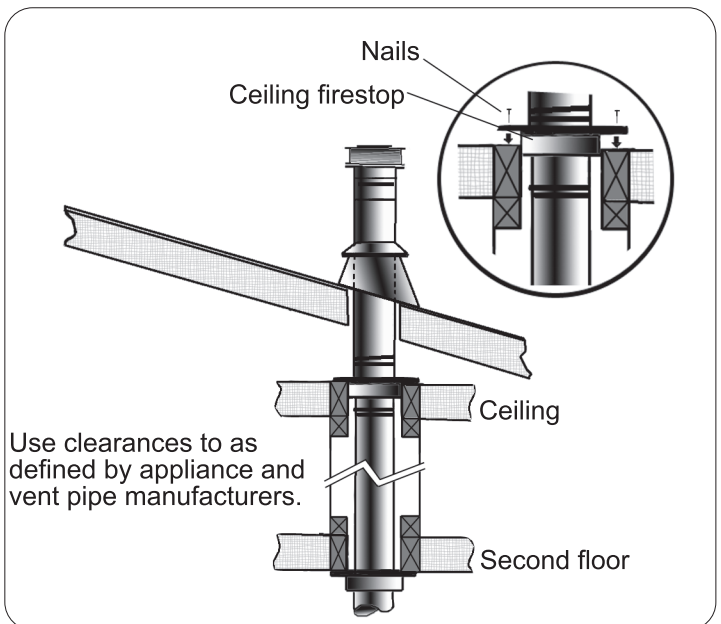
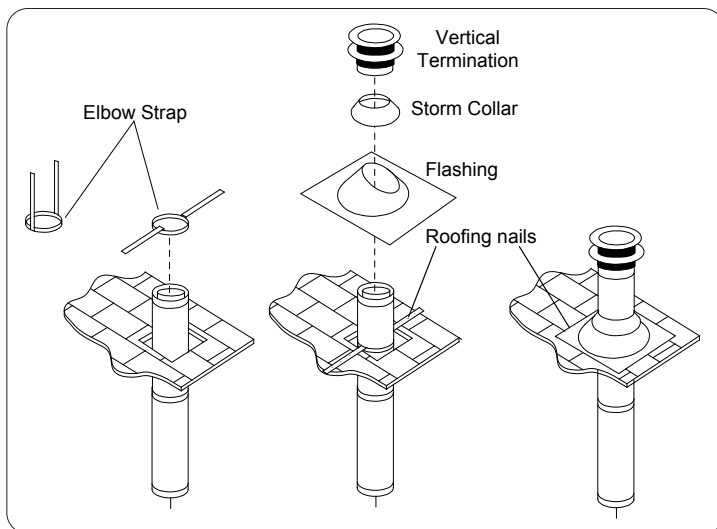
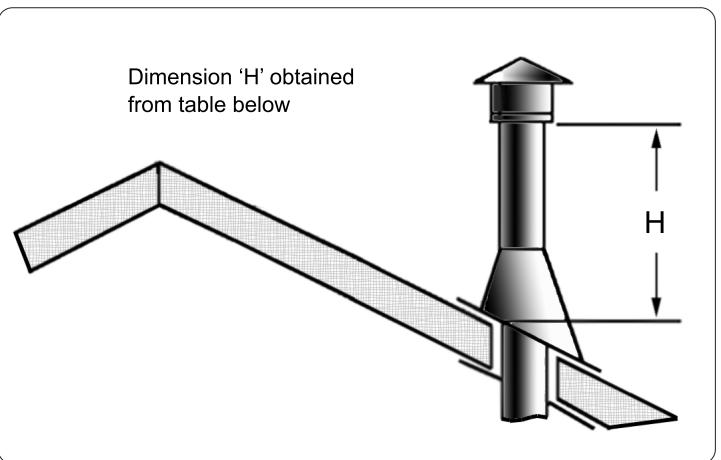

1. If an offset is necessary in the attic to avoid obstructions, it is important to support the vent pipe every **3' (914 mm)** using wall straps to avoid excessive stress on the elbows.
2. Use 45° degree elbows instead of 90° degree elbows when ever possible. The 45° degree elbow offers less restriction to the flow of flue gases and intake air.

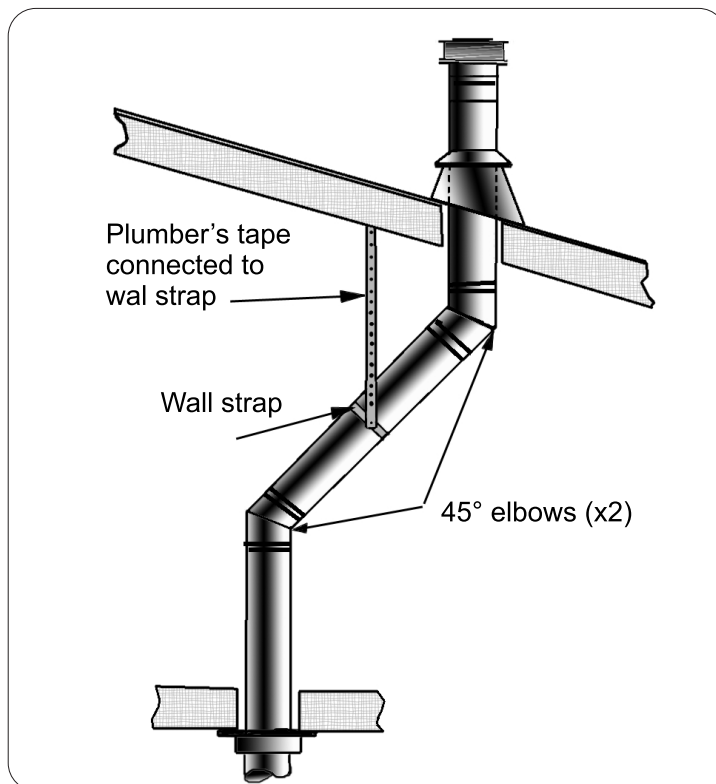

### Horizontal Termination:

**1. A minimum 1ft vertical section before an elbow is required when horizontally terminating with an approved venting cap.**

**2. Horizontal pipes must not be level. For every 12" (305 mm) of horizontal travel there should be at least 1/4" (6.4 mm) of vertical rise. Never allow the vent to run downward, as this could cause high temperatures or even present the possibility of a fire.**

**3. The exterior of the horizontal vent termination must not be blocked or obstructed.**

**4. If the vent termination is not being attached to wood, the four wood screws provided should be replaced with material appropriate fasteners.**

**5. For buildings with vinyl siding, a vinyl standoff should be installed between the vent cap and the exterior wall. Attach the vinyl siding standoff to the horizontal termination. The termination attaches to the flat portion of the standoff which provides an air space between the wall and the vent termination. The air gap prevents excessive heat from possibly melting the vinyl siding.**

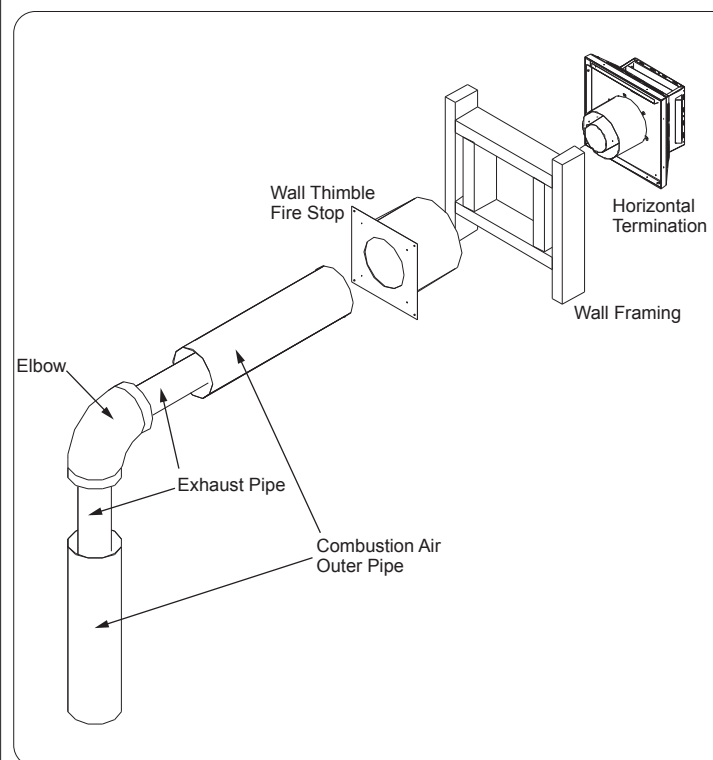

**6. Horizontal pipes must be supported every 3' (914 mm). Plumber's "all round" strap will suffice.**

**7. Clearances to combustibles must be maintained when running horizontal pipe. 1" (25 mm) sides, 1" (25 mm) bottom, 3" (76 mm) top, and 3" (76 mm) above elbows outside the immediate chase.**

**8. Set the fireplace in the desired location. Check to determine if wall studs will be in the way when the venting system is attached. If this is the case, the location of the fireplace may have to be adjusted or the venting may have to be offset.**

**9. Many direct vent pipe sections are designed with special twist-lock connections. Dry fit the desired combination of pipe**

## Wall / Ceiling Thimble

Use a OFFSET wall thimble when passing through an exterior wall or ceiling. Typically the framing hole will be 10 1/2" x 10 1/2" but each thimble manufacturer may vary. Installations in Canada require a wall thimble be used but they are recommended for all installations. All sealing and vapour barriers must comply with local building codes.

Use a fire stop when passing through interior joints of subsequent floors.

Manufacturer	Trade Name	Nominal Sizes
ICC	EXCELDirect	5"x8"&4"x6-5/8"
M&G Dura-Vent	Direct Vent Pro	5"x8"&4"x6-5/8"
Selkirk	DIRECT-TEMP	5"x8"&4"x6-5/8"
Sekirk	AMP DV	5"x8"&4"x6-5/8"
Metal-Fab	Sure-Seal	5"x8"&4"x6-5/8"

Refer to the table (next page) for part numbers of commonly used parts for approved venting systems. Please visit the respective manufacturers' website for more information.

Minimum Vent Clearances	
Vertical Pipe to Studs	1" (25mm) all around
Above Horizontal Pipe	3" (76 mm)
Horizontal Pipe Sides & Bottom	1" (25 mm)
Above First Elbow	See right image
Above Additional Elbows	3" (76 mm)

## Venting Clearances

**Clearances must be in accordance with local installation codes and requirements of the gas supplier.**

**WARNING: Do not mix parts from different vent manufacturers' systems.**

### EXCEPTION TO WARNING:

This product has been evaluated by Intertek using a DirectVent Pro starting collar in conjunction with other venting manufacturers. Using the DirectVent Pro starting collar is deemed acceptable and does not affect the Intertek listing of the appliance.

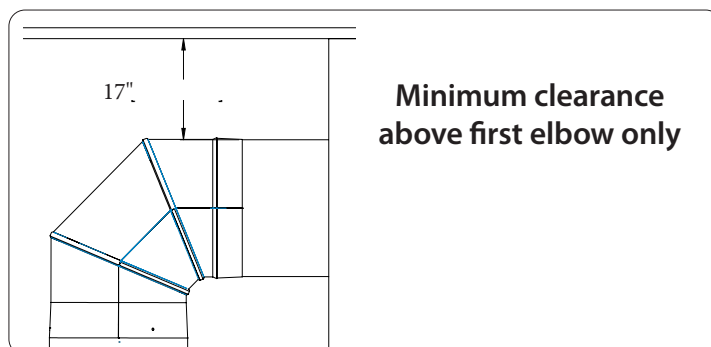
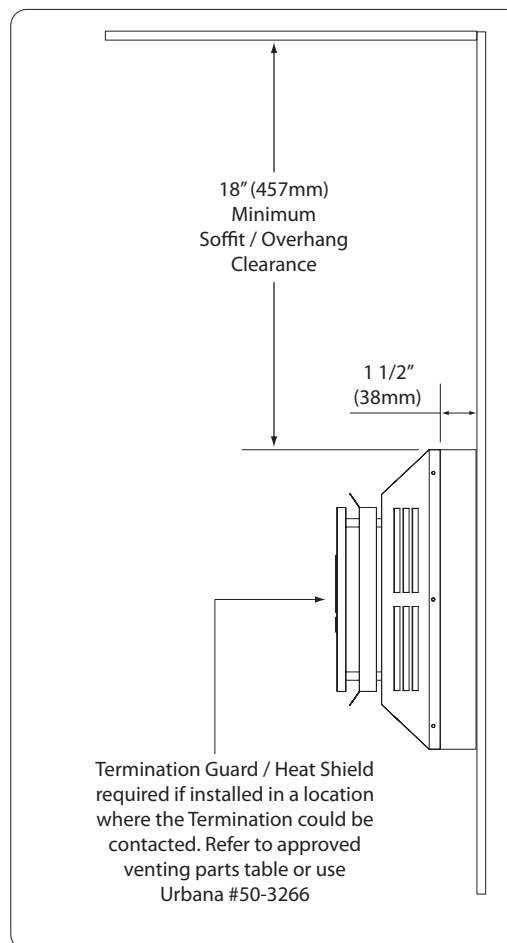

**Note - The Power vent electrical connection is accessible from the outside of the unit via the cover plate. It can also be accessed from inside the unit via the Removable control panel shown on page 17**

Power vent allows for venting installations that falls outside of the venting chart on page 28 & 29. If this is required for your installation, you will need to purchase the powervent kit.

**50-3883 (Horizontal Power vent)**

or

**50-4375 (Vertical Power Vent)**

**(use the installation manual with the power vent kit for instruction on how to install the unit in the wall.)**

### Power vent Unit Connection

To connect the Powervent to your unit follow the following steps.

**1.** Remove Yellow Jumper on the right hand connector block.

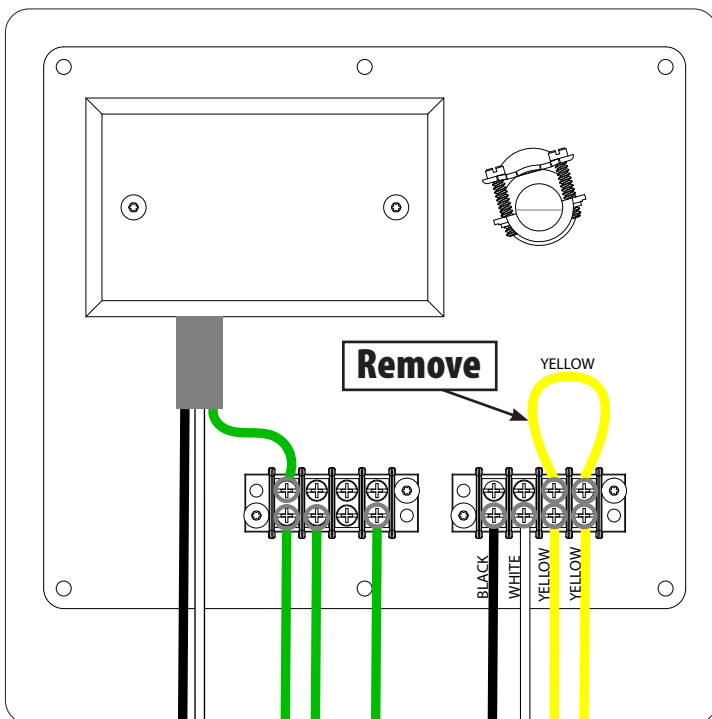

**2.** Bring in the 5 wire cable from the power Vent

**3.** Secure the incoming cable with the strain relief above the right hand side connector bar mounted on the plate.

**4.** Remove the cover plate over the connector block on the left hand side to expose the ground terminals. (Cover plate not shown in image below)

**5.** Using the diagram below connect the 5 wires from the power head to the connector block. (The power vent kit is used in multiple units. You may need to cut off existing quick connects on the wires coming into the unit.)

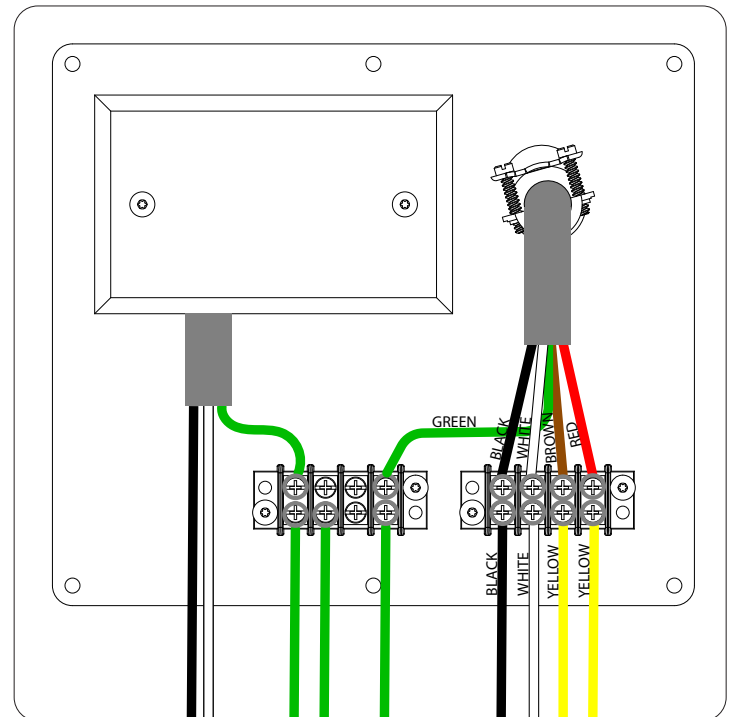

**6.** Replace the cover plate for the ground connector block.

**7.** Reattach plate to outside of cabinet.

## Venting Chart

The Power vent allows the unit to be used with up to 95ft of venting. On shorter vent runs the fan voltage should be reduced. This will restrict the combustion air leading to a better flame quality and appearance.

Use the chart below to set the rheostat based on your vent run. This Chart is for both NG & LP Fuel Types

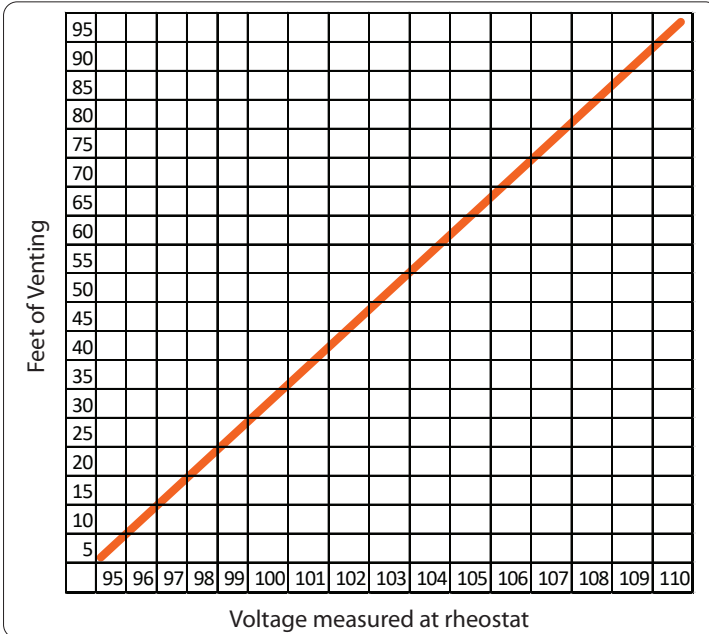

## Initial Startup (Rheostat voltage setting)

The unit comes with test ports to allow you to use a multi meter to see the voltage going to the power vent fan. You will need to set the rheostat voltage on your first initial firing of the unit.

To access the test ports, remove the screen.

(see page 13) Underneath the control panel on the right hand side. You will see the rheostat. The test ports are

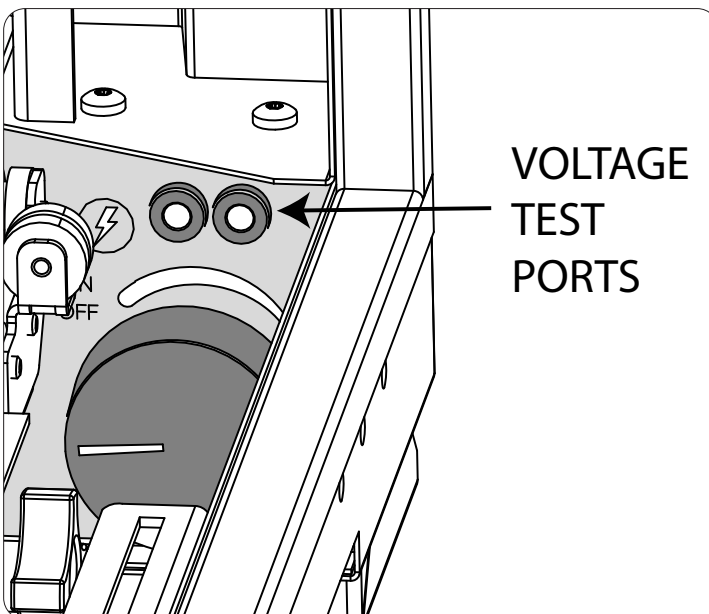

situated above the rheostat.

Initial startup assumes you have completed the previous installation sections of this manual.

1. Verify burner switch on the side control panel is set to the ON position  
1 = on 0 = Off -

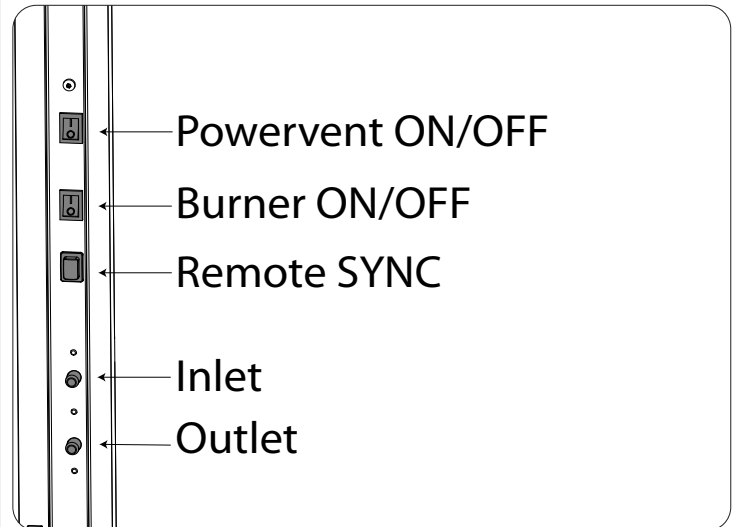

2. Switch top switch to the POWERVENT Position
3. Ensure rheostat is set to Maximum for initial startup. To do that rotate rheostat all the way anti-clockwise until a "click" is heard (that is now in the off position.) Now rotate clockwise. Just after the "click" It is at its maximum voltage.
4. Use your remote to turn on the unit. This can take up to 30 Seconds When using the Power vent. Refer to trouble shooting section of this manual on page 44 if the unit does not start)
5. When the unit is running insert your probes into the test ports dial down the voltage based on the venting chart. Once the voltage is set, you will not need to adjust the voltage again.

### IMPORTANT NOTE

**Do not set the Rheostat below 95 volts. The pressure switch in the power vent will not activate, and your unit will not turn on.**

M&G Duravent Direct Vent Pro	ICC EXCELDirect	Selkirk DIRECT-TEMP	Amerivent AMV DV	Metal-Fab Sure-Seal DV	Description
58DVA-06	5DL6	5DT-06		5D6	6" pipe length
			5D7		7" pipe length
58DVA-09	5DL9	5DT-09			9" pipe length
58DVA-12	5DL1	5DT-12	5D12	5D12	12" pipe length
58DVA-18		5DT-18		5D18	18" pipe length
58DVA-24	5DL2	5DT-24	5D2	5D24	24" pipe length
58DVA-36	5DL3	5DT-36	5D3	5D36	36" pipe length
58DVA-48	5DL4	5DT-48	5D4	5D48	48" pipe length
58DVA-60					60" pipe length
58DVA-E30					30° elbow
58DVA-E45	5DE45	5DT-EL45	5D45L	5D45L	45° elbow
58DVA-E90	5DE90	5DT-EL90	5D90L	5D90A, 5D90L	90° elbow
58DVA-VSS, DVA-BVS	VSS	5DT-VS/VSK	5DHVS, DVSK	5DVS	Vinyl siding standoff/sheild
58DVA-WT3, 58DVA-WTU3	5WT	5DT-WT	5DWT	5DWT, 5DWT11	Wall thimble
58DVA-SC	SQSC, SC	5DT-SC	5DSC	5DSC	Storm collar
58DVA-WFS		5DT-FS		5DFSH	Wall Fire stop
58DVA-FS	5CS	5DT-FS	5DFSP	5DFS, 5DSPFS	Ceiling Fire stop
58DVA-IS	5AS	5DT-AIS	5DAIS12, AIS36	5DIS	Attic Insulation Shield
58DVA-WS	5WS	5DT-WS/B	5DWS	5DWS	Wall strap/support/band
58DVA-VCH	5SVT			5DVT	High wind vertical termination
58DVA-HC	5HT	5DT-HC	5DHCS	5DHT	High wind horizontal termination
46DVA-WG	HTS		4DHWS	8DVTS	Wind / Heat Shield
				5DAL	3" to 10" pipe, adjustable
58DVA-17TA					11" to 17" pipe, adjustable
58DVA-24TA					17" to 24" pipe, adjustable
	5DLA30				16.5" to 29" pipe , adjustable
	5DLS1				1 7/8" to 9" slip length pipe
	5DLS2				1 7/8" to 21" slip length pipe
58DVA-F6	6EFA	5DT-AF6	5DF	5DF	Flashing, 0/12 to 6/12 roof pitch
58DVA-F12	6EFB	5DT-AF12	5DF12	5DF-12	Flashing, 7/12 to 12/12 roof pitch
58DVA-FF	6EF			5DFT	Flat Roof Flashings
58DVA-CFK	4MF				Masonry Flashing

M&G Duravent Direct Vent Pro	ICC EXCELDirect	Selkirk DIRECT-TEMP	Amerivent AMV DV	Metal-Fab Sure-Seal DV*	Description
46DVA-06	4DL6	4DT-06		4D6	6" pipe length
			4D7		7" pipe length
46DVA-09	4DL9	4DT-09			9" pipe length
46DVA-12	4DL1	4DT-12	4D12	4D12	12" pipe length
46DVA-18		4DT-18		4D18	18" pipe length
46DVA-24	4DL2	4DT-24	4D2	4D24	24" pipe length
46DVA-36	4DL3	4DT-36	4D3	4D36	36" pipe length
46DVA-48	4DL4	4DT-48	4D4	4D48	48" pipe length
46DVA-60					60" pipe length
46DVA-E30					30° elbow
46DVA-E45	4DE45	4DT-EL45	4D45L	4D45L	45° elbow
46DVA-E90	4DE90	4DT-EL90	4D90L	4D90A, 4D90L	90° elbow
46DVA-VSS, DVA-BVS	VSS	4DT-VS/VSK	4DHVS, DVSK	4DVS	Vinyl siding standoff/sheild
46DVA-WT, 46DVA-WTU	4WT	4DT-WT	4DWT	4DWT, 4DWT11	Wall thimble
46DVA-SC	SQSC, SC	4DT-SC	4DSC	4DSC	Storm collar
46DVA-WFS		4DT-FS		4DFSH	Wall Fire stop
46DVA-FS	4CS	4DT-FS	4DFSP	4DFS, 4DSPFS	Ceiling Fire stop
46DVA-IS	4AS	4DT-AIS	4DAIS12, AIS36	4DIS	Attic Insulation Shield
46DVA-WS	4WS	4DT-WS/B	4DWS	4DWS	Wall strap/support/band
46DVA-VCH	4SVT			4DVT	High wind vertical termination
46DVA-HC	4HT	4DT-HC	4DHCS	4DHT	High wind horizontal termination
46DVA-WG	4HTS		4DHWS	8DVTS	Horizontal Wind / Heat Guard
46DVA-VWG	4SVTS				Vertical Wind Guard
				5DAL	3" to 10" pipe, adjustable
46DVA-17TA					11" to 17" pipe, adjustable
46DVA-24TA					17" to 24" pipe, adjustable
	4DLA30				16.5" to 29" pipe , adjustable
	4DLS1				1 7/8" to 9" slip length pipe
	4DLS2				1 7/8" to 21" slip length pipe
46DVA-F6	6EFA	4DT-AF6	4DF	5DF	Flashing, 0/12 to 6/12 roof pitch
46DVA-F12	6EFB	4DT-AF12	4DF12	5DF-12	Flashing, 7/12 to 12/12 roof pitch
46DVA-FF	6EF			5DFT	Flat Roof Flashings
46DVA-CFK	4MF				Masonry Flashing
46DVA-KCA	4CA6	4DT-CCKA	4DRCKA		Chimney Conversion Kit A [USA only]
46DVA-KCB	4CA7	4DT-CCKB			Chimney Conversion Kit B [USA only]
46DVA-KCC	4CA8				Chimney Conversion Kit C [USA only]

\*When using Metal-Fab Sure Seal a Duravent Appliance Adaptor, part #4DDA, is required



Step 1

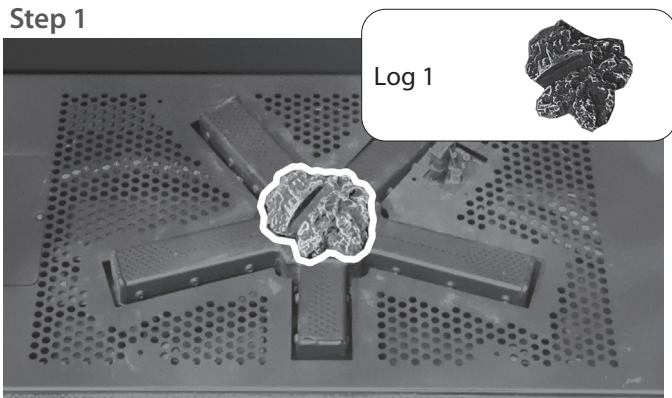

Step 2

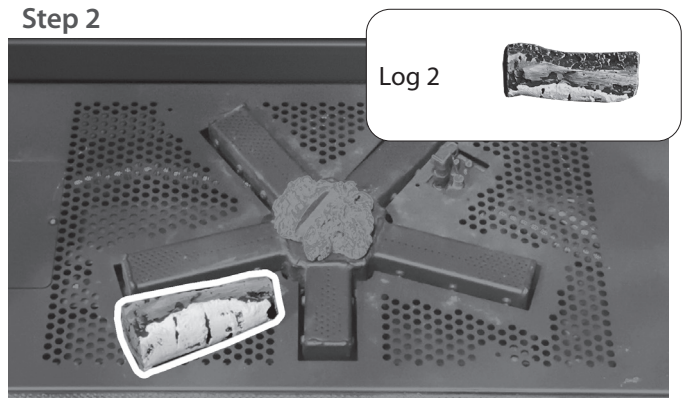

Step 3

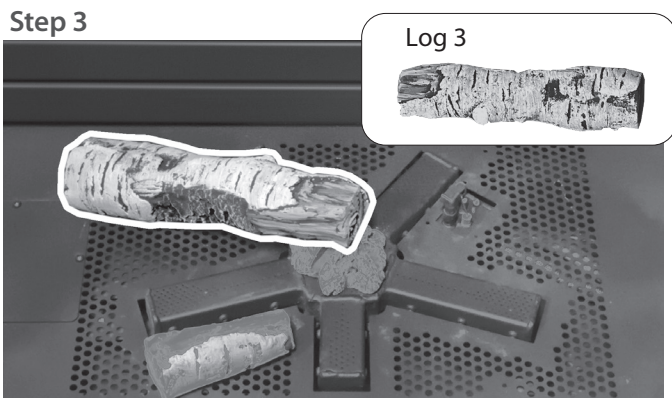

Step 4

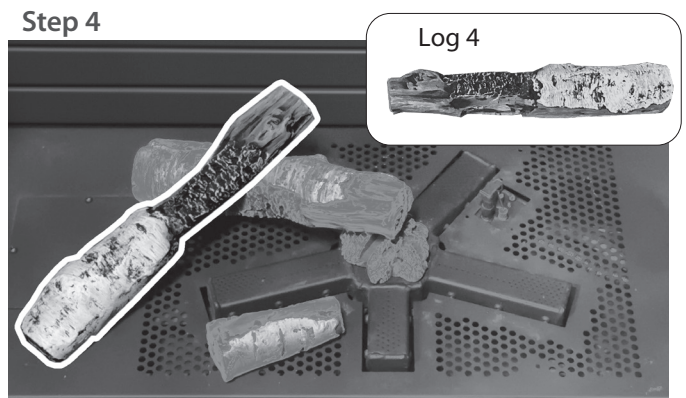

Step 5



Step 6

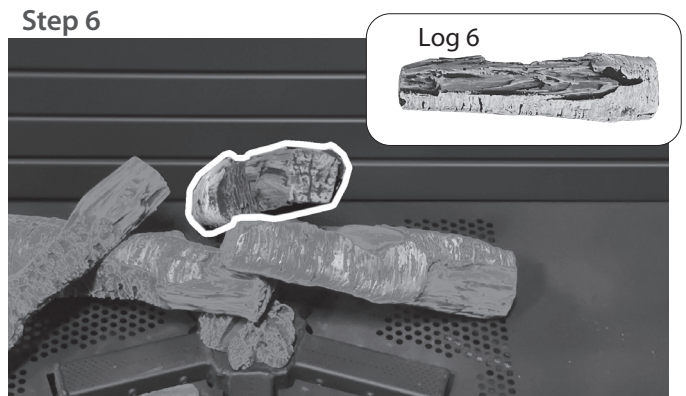



## Step 7

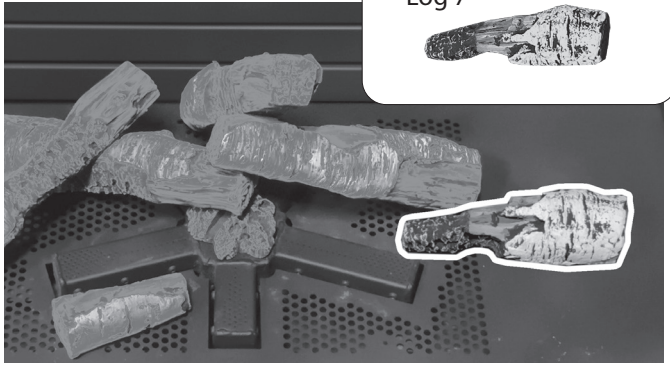

## Step 8



## Step 9

Cover the perforated area with ember wool.



Ember Wool



## Step 10

Fill remaining space with vermiculite keeping clear of the venturi adjustment hatch.



Vermiculite



## Step 11

Test the burner and adjust venturi as needed. Afterwards cover the hatch with vermiculite.



## Step 12

Disperse coals to your preference.



Coals



## Step 13

Press glass intermittently along the perimeter of the ember wool.

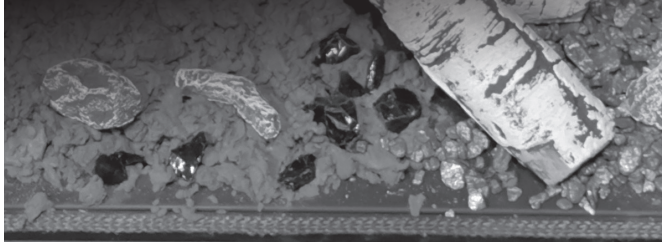

Glass



## Completed Log Set



## Flame Appearance



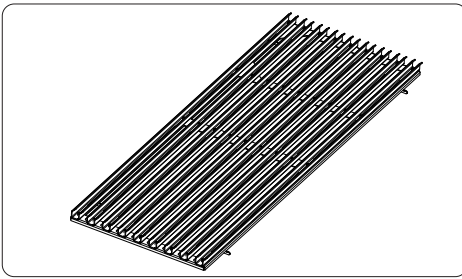

50-4399 U33T Baffle

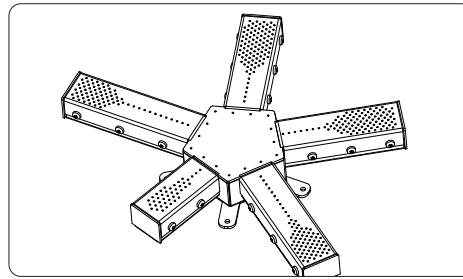

50-4400 U33/U33T Burner only

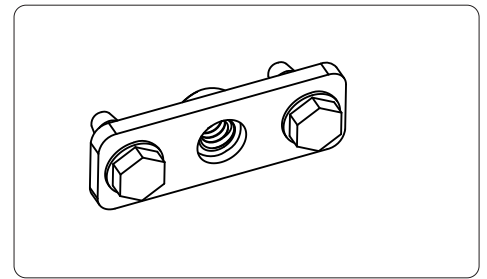

50-4401 U33/U33T PEM bracket

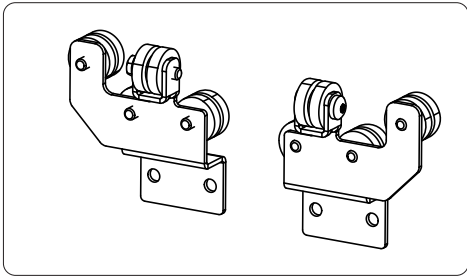

50-4402 U33/U33T Glass Bumper Set (L & r)

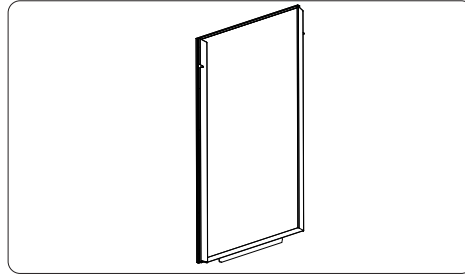

50-4319 U33T Safety Screen

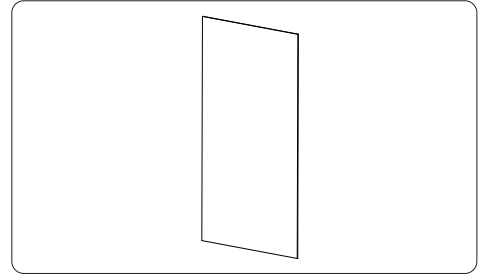

50-4164 U33 Glass

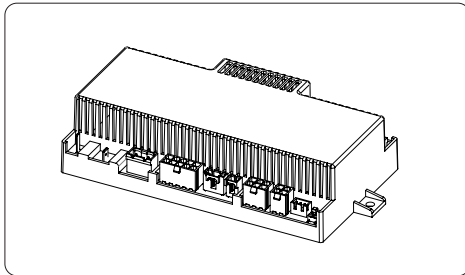

# 50-3887 IFC Urbana

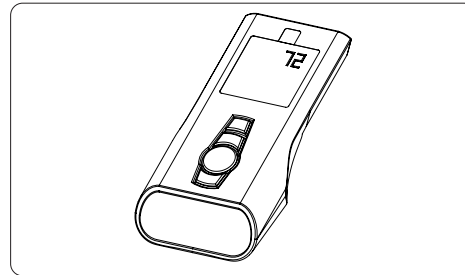

#50-3888 - PF2 WiFi Ready Transmitter

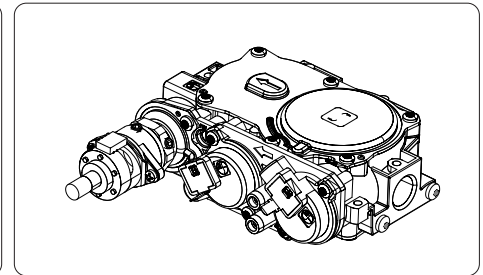

#50-2682 - SIT 885 VALVE W/ STEPPER MOTOR (NG)

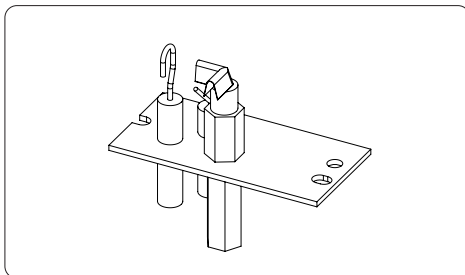

#50-4056 Urbana ipi pilot assembly

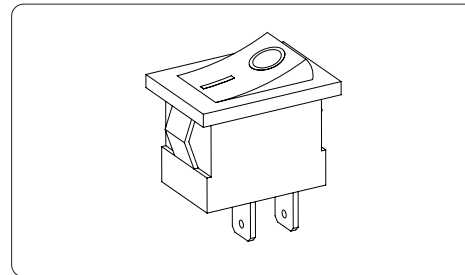

#50-3892 - Urbana Rocker Switch

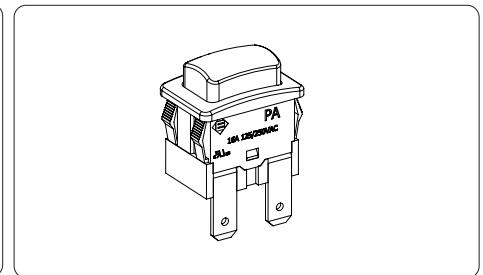

#50-3518 ifc reset switch

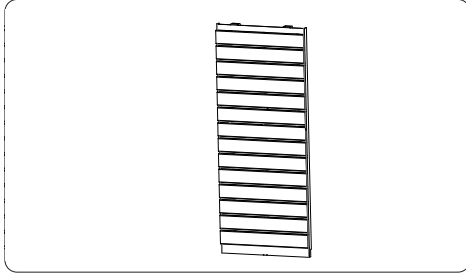

**50-4463 Horizontal liner - side**

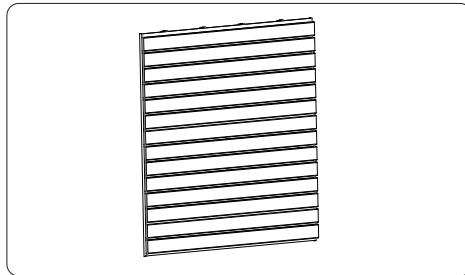

**50-4464- Horizontal Liner - Rear**

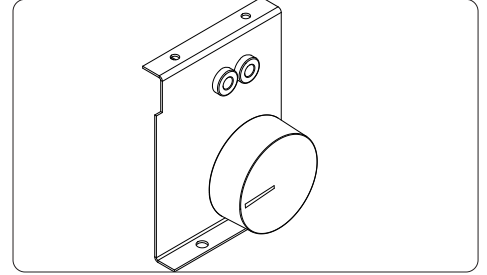

**50-4408- Power vent Rheostat Assembly**

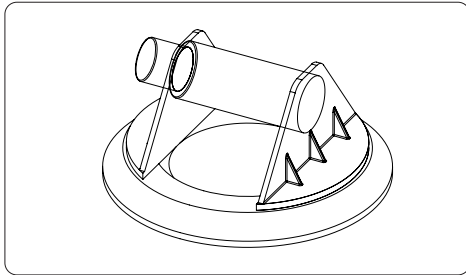

**#50-3837 - SUCTION cup HANDLE (1 PC)**

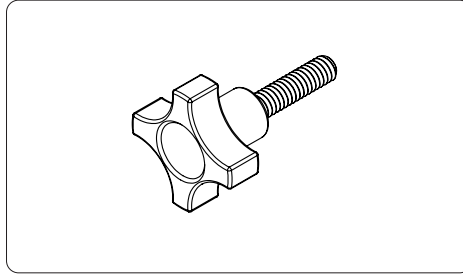

**#50-4279 - Glass hand knob (metal)**

Gaskets	Part numbers
U33T Firebox Braided Gasket single side	#50-4409
U33/U33T Control panel Gasket	#50-4410
U33/U33T Bulkhead Gasket	#50-4411

Wire Harnesses	Part Numbers
ProFlame 2 IFC Wire Harness	#50-3030

Problem	Cause	Solution	Check (In order of likeliness)
Burner doesn't turn on	IFC ON/OFF circuit is OPEN	Ensure ON/OFF circuit is complete (check with multimeter)	Check the ON/OFF switch, confirm "-" symbol is pressed down Check for continuity across burner switch Check for continuity across timing relay terminal A and B (see "Safety Circuit System")
	Remote signal not being received	Ensure IFC is receiving remote commands (audible beeps) **Remote commands may need to be repeated	Re-sync remote Weak or dead remote batteries Check receiver antenna is in correct location (see "Fireplace Control Panel") Check for red blinking light on IFC (see "IFC Locked out" below)
	No call for heat	Ensure heat has been called for	Check thermostat setting is below set point Check third party fireplace control
	Unresponsive IFC	Ensure IFC is working correctly *audible beeps confirms IFC is getting power	Check circuit breaker Check for 120VAC at IFC Check IFC fuse Check for red blinking light on IFC (see "IFC error" troubleshooting section)
	Problem with pilot	Ensure pilot flame is operational	See "Pilot flame not lighting.." below
Pilot not attempting to spark	No call for heat	Ensure heat has been called for	Check thermostat setting is below set point Check third party fireplace control
	Locked out IFC	Reset IFC	See "Unresponsive fireplace" below
	Power vent (PV) circuit is CLOSED	Ensure PV system is working	See "Fireplace unresponsive" below
	Spark signal interrupted	Ensure complete sparker circuit	Check electrode rod not shorting out on burner platform - adjust rod only if necessary Check electrode wire not shorting out (especially at aluminum pilot line) Check orange electrode wire has firm connection at IFC Check pilot electrode orientation to pilot hood - should be no more than 1/4" away
	Problem with pilot	Ensure pilot flame is operational	See "Pilot flame not lighting.." below
Pilot flame not lighting or weak flame (has spark at hood)	Air in pilot gas line	Purge pilot gas line	May take a few ignition cycles for gas to self-purge (may need to hard reset IFC after cycles)
	Not enough gas pressure	Ensure gas is reaching pilot	Check gas inlet supply and pressure (see "Gas Connections") Check for complete wiring connections at valve (look for faux connections) Check pilot is set-up for correct fuel-type Check for pilot flame obstructions (typically burner media) Check for debris in pilot line at pilot head (typically propane units) Check pilot flame adjustment screw on valve Check for pilot line leak - do you smell gas?
Pilot flame not staying lit	7 continuous days with no burner operation	Re-start fireplace using remote	This is normal
	Problem with flame sensor circuit	Ensure healthy flame rectification	Ensure sensor hook is glowing bright red Check for healthy pilot; ensure sensor hook is fully engulfed in flame Check sensor hook is not touching pilot hood Check white sensor wire has firm connection with IFC Check sensor hook for corrosion, film, or debris Check pilot for healthy ground (check pilot hood continuity)
	Exhaust Restrictor Setting	Ensure correct exhaust restriction setting	See "Venting Configuration"
Flame dropping out (visual flame problems)	Improper fireplace settings	Ensure proper fireplace settings	Check exhaust restrictor setting; see "Venting Configuration" Check venting configuration is approved Check for venting obstructions (including at termination cap) Check primary air setting; see "Primary Air Adjustment"
	Weak or erratic pilot flame	Ensure pilot flame is healthy	Check flame sensor circuit; see "Pilot flame not staying lit"
	Environmental conditions (windy)	Fireplace adjustment may be necessary	Check for approved high-wind termination cap Check for proper fireplace settings (see above) Adjust exhaust restrictor only if necessary
	Environmental conditions (extreme cold)	Use "Continuous Pilot" mode (CPI)	This will help the fireplace establish draft when freshly turned on
Flame dropping out (no visual flame problems)	Problem with safety circuit	Ensure safety system is functioning correctly	Review safety system; see "Safety Circuit System" Check monitored fan(s) are functioning at a decent speed Check for complete sail switch operation Check for continuity across sail switch terminals A and B (see "Safety Circuit System") Check monitored fan(s) are functioning at a decent speed Check for complete sail switch operation

	Not enough gas supply	Ensure proper gas flow and pressure Ensure pilot is operational	Check for continuity across sail switch terminals A and B (see "Safety Circuit System") Check fuel supply and gas test ports (see "Gas Connections") See "Pilot flame not staying lit"
Flame cycling on/off (irritating clicking)	Sail switch(s) fluttering	Ensure proper sail switch operation	Check for weak fan (monitored) - See above Ensure sail paddle is in direct air flow Ensure cooling fan is properly mounted on isolators; fan must be level Ensure sail switch body is secured in proper position
Flame lifting	Too much primary air	Decrease primary air by closing air shutter (venturi)	See "Adjusting Primary Air Setting"
	Exhaust restrictor setting	Improper exhaust restrictor setting	See "Venting Configuration"; adjust only if necessary
	Problem with venting system	Ensure venting system is properly set-up	Check for approved high-wind termination cap Check venting configuration is approved Check for leaks in venting system
	Input rate too high	Ensure correct gas orifice size and manifold pressure	See rating label for details
	Trouble establishing draft (weather related)	Use "Continuous Pilot" mode (CPI)	This will help the fireplace establish draft when freshly turned on
Flame weaving, bending or uneven (some is normal)	Poor firebox seal	Ensure complete seal at glass braided gasket  Ensure firebox sealed	Ensure all hand knobs are tight - ensure upper clamps are in correct slot location Check for dirt or particles sticking to strips; use denatured alcohol to clean Check for damaged fiberglass perimeter tape
	Uneven secondary air distribution	Ensure burner platform is secured  Ensure even air slot height around burner Back and forth warping of diffuser mesh (U70 NG models)	Check for missing or stripped screws Check for warping in burner platform (when installed) Check for unsettled burner platform (sitting on a screw, liner clip, or weld build up) This is normal
	Incorrect media placement	position logs around arms of burner	Check for logs/rocks covering air slots  Check for foreign burner media
	Leaking burner	Ensure burner is sealed	Visually inspect burner for leaks; replace if necessary - DO NOT TEST WITH OPEN FLAME
Blue flames (excessive)	Fireplace is warming up	Flames will yellow as fireplace heats up	This is normal
	Too much primary air	Decrease primary air by closing air shutter (venturi)	See "Adjusting Primary Air Setting" Poor air shutter seal on venturi box
Rich flames (excessive)	Exhaust restrictor setting	Improper exhaust restrictor setting	See "Venting Configuration"; adjust only if necessary
	Not enough primary air	Increase primary air by opening air shutter (venturi) Remove venturi box covers for even more primary air (NG)	See "Adjusting Primary Air Setting" Check that the venturi box covers are removed (LP)
	Improper exhaust restrictor setting	Adjust exhaust restrictor setting	See "Venting Configuration"; adjust only if necessary
	Problem with venting system	Ensure venting system is properly set-up	Check for approved high-wind termination cap Check venting configuration is approved Check venting system for leaks
	Incorrect media placement	Adjust burner media	Check log positioning Check burner media quantity (should be one layer deep) Check for obstructed secondary air slots around burner
	Incorrect gas input rate	Ensure gas input spec's match rating label	Check gas inlet pressure Check gas manifold pressure (with unit running) Check gas orifice matches rating label for correct fuel type
Glass fogs on start-up	Condensation is formed on start up	Use "Continuous Pilot" mode (CPI)	This is normal, more so in damper climates
Glass gets hazy over time	Additives in gas accumulates on glass	Use "Continuous Pilot" mode (CPI)	This will reduce the build-up rate; clean as necessary
Fireplace gets excessively hot	Chase construction obstruction	Ensure all installation spec's are met Ensure no air flow obstructions Ensure all appropriate heat shields are installed	Ensure air intake and heat release areas are at or above minimum spec Check for foreign objects blocking air intake and heat release (even a relaxing pet) Check installation section for further details
	Material encroaching on minimum clearances	Ensure all installation spec's are met	Check installation section for further details Ensure there're no foreign objects on or above the unit within the chase
	Problem with venting system	Ensure venting system is properly set-up	Check venting configuration is approved Check for venting obstructions
	Exhaust restrictor setting	Exhaust restrictor setting too high	Reduce exhaust restriction
	Incorrect gas input rate	Ensure gas input spec's match rating label	Check gas inlet pressure Check gas manifold pressure (with unit running) Check gas orifice matches rating label for correct fuel type
IFC locked out (flashing red light)	Pilot ignition sequence timed out	Ensure healthy pilot operation	See "Pilot not lighting.."
	Fireplace lost gas supply	Ensure proper gas flow and pressure	Check gas inlet supply and pressure
	Problem with safety circuit system (flame shuts off after 10-20 minutes)	Ensure safety system is functioning correctly	Check monitored fan(s) are functioning at a decent speed
	IFC confused	Soft reset IFC Hard reset IFC	Press reset button on fireplace switch panel and re-sync remote (tool may be required) Cut power to IFC (could use circuit breaker) and reconnect
Fireplace unresponsive	No power to fireplace	Ensure the fireplace is seeing 120VAC	Check circuit breaker Do any fireplace features work? If so, fireplace has power Check for 120VAC at the IFC
	Blown IFC fuse	Replace IFC fuse with exact replacement	Check for bare electrical connections Check for electrical short in top light box Was there a recent power surge?
	IFC locked out	Reset IFC	See "IFC locked out" for possible causes

#### U33 WIRING DIAGRAM SCHÉMA DE CÂBLAGE

Circuit only used with either  
50-3883 Horizontal Power Vent  
50-4375 Vertical Power Vent

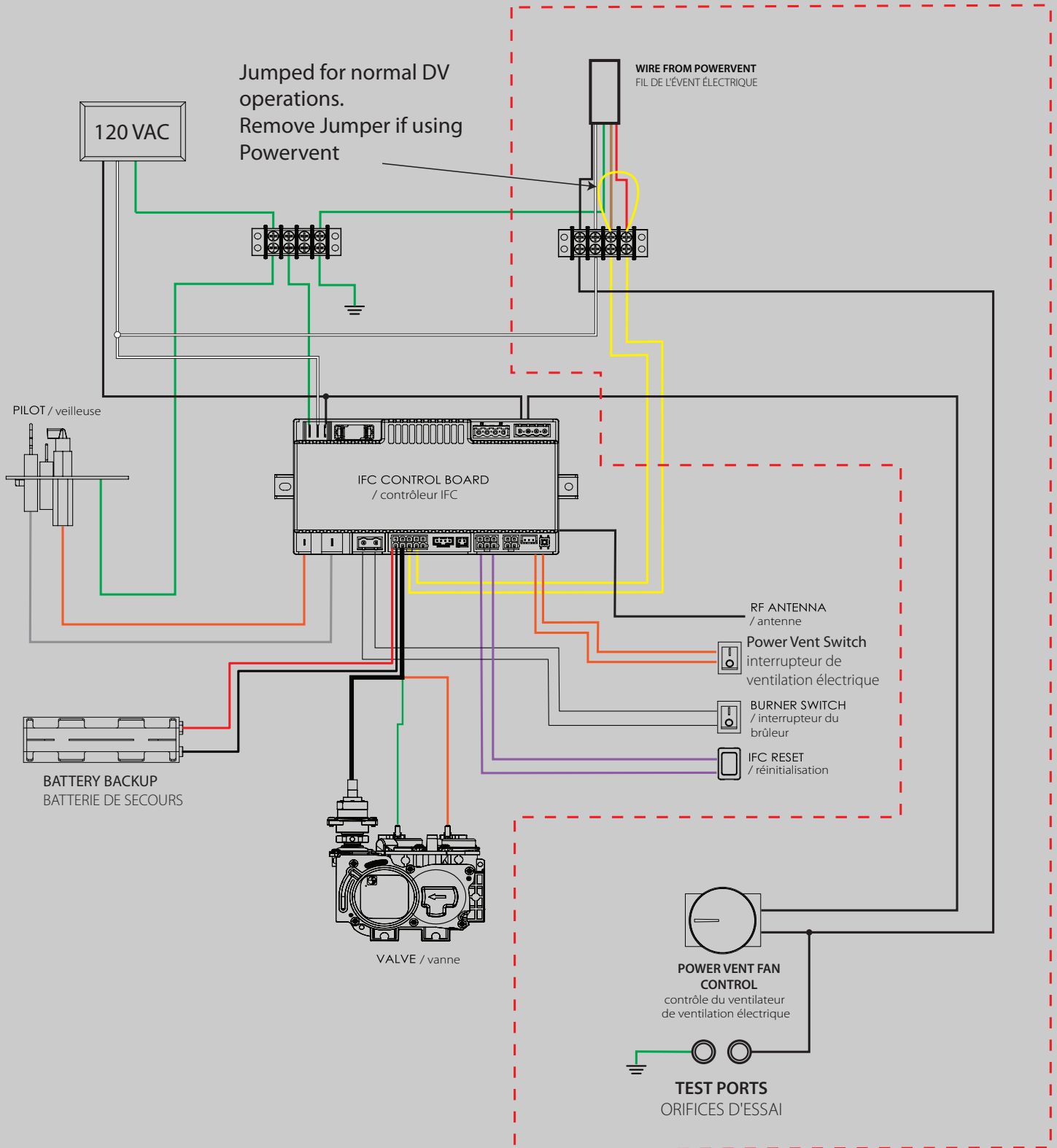

**Please fill in and retain this information card for your future reference.**

Go to [www.urbanafireplaces.com/warranty](http://www.urbanafireplaces.com/warranty) to fill in your warranty registration card.

**NAME OF DEALER:**

\_\_\_\_\_

**ADDRESS:**

\_\_\_\_\_

\_\_\_\_\_

\_\_\_\_\_

**PHONE:** \_\_\_\_\_

**NAME OF INSTALLER:**

\_\_\_\_\_

**ADDRESS:**

\_\_\_\_\_

\_\_\_\_\_

\_\_\_\_\_

**PHONE:** \_\_\_\_\_

**MODEL:** \_\_\_\_\_

**SERIAL NUMBER:** \_\_\_\_\_

**DATE OF PURCHASE:** \_\_\_\_\_ (dd/mm/yyyy)

**DATE OF INSTALLATION:** \_\_\_\_\_ (dd/mm/yyyy)

NATURAL GAS (NAT)       PROPANE(LPG)

**INLET GAS PRESSURE:** \_\_\_\_\_ in wc

**MAIN BURNER ORIFICE:** \_\_\_\_\_ # DMS

**PILOT ORIFICE #** \_\_\_\_\_ **OR** \_\_\_\_\_ in diam.

**INSTALLER'S SIGNATURE:**

\_\_\_\_\_



Sherwood Industries Ltd. ("Sherwood") hereby warrants, subject to the terms and conditions herein set forth, this product against defects in material and workmanship during the specified warranty period starting from the date of original purchase at retail. In the event of a defect of material or workmanship during the specified warranty period, Sherwood reserves the right to make repairs or to assess the replacement of a defective product at Sherwood's factory. The shipping costs are to be paid by the consumer. All warranties by Sherwood are set forth herein and no claim shall be made against Sherwood on any oral warranty or representation.

**Conditions**

- A completed warranty registration must be submitted to Sherwood within 90 days of original purchase via the online warranty registration page or via the mail-in warranty registration card provided. Have the installer fill in the installation data sheet in the back of the manual for warranty and future reference.
- This warranty applies only to the original owner in the original location from date of install.
- The unit must have been properly installed by a qualified technician or installer, and must meet all local and national building code requirements.
- The warranty does not cover removal and re-installation costs.
- Sherwood Industries Ltd. reserves the right to make changes without notice.
- Sherwood Industries Ltd. and its employees or representatives will not assume any damages, either directly or indirectly caused by improper usage, operation, installation, servicing or maintenance of this appliance.
- A proof of original purchase must be provided by you or the dealer including serial number.

▪ **Exclusions**

An expanded list of exclusions is available at [www.urbanafireplaces.com/warranty.html](http://www.urbanafireplaces.com/warranty.html)

This warranty does not cover:

- Damage as a result of improper usage or abuse.
- Damage caused from over-firing due to incorrect setup or tampering.
- Damage caused by incorrect installation.
- Any discoloration of the safety screen mesh.

**To the Dealer**

- Provide name, address and telephone number of purchaser and date of purchase.
- Provide date of purchase. Name of installer and dealer. Serial number of the appliance. Nature of complaint, defects or malfunction, description and part # of any parts replaced.
- Pictures or return of damaged or defective product may be required.

**To the Distributor**

- Sign and verify that work and information are correct.

**Sherwood Industries Ltd.**

6782 Oldfield Road, Victoria, BC . Canada V8M 2A3

Online warranty registration: [www.urbanafireplaces.com/product-registration/](http://www.urbanafireplaces.com/product-registration/)

Category	One Year	Two Year	Limited Lifetime (7yr)
Parts <sup>1</sup> (unit serial number required)		✓	
Firebox Liner Panels <sup>2</sup>		✓	
Firebox			✓
Burner			✓
Ceramic Logs <sup>3</sup>			✓
Ceramic Glass <sup>4</sup>	✓		
Door Assembly			✓
Exterior Panels (excluding finish) <sup>5</sup>			Up to 5 years
Electrical Components		✓	
Labour	✓		

<sup>1</sup> Whereas warranty has expired, replacement parts will be warrantied for 90 days from part purchase date. Labour not included. Unit serial # required.

<sup>2</sup> Excluding damage to the finish caused by improper setup of the appliance, or color changes.

<sup>3</sup> Log set and panels excludes wear and tear or breakage caused by cleaning or service.

<sup>4</sup> Glass is covered for thermal breakage. Photos of box, inside of door, and unit serial # must be supplied for breakage due to shipping.

<sup>5</sup> Exterior Surface finishing covers plating, enamel or paint and excludes colour changes, chipping, and fingerprints. Travel costs not included.

MANUFACTURED BY:  
SHERWOOD INDUSTRIES LTD.  
6782 OLDFIELD RD. SAANICHTON, BC, CANADA V8M 2A3  
[www.urbanfireplaces.com](http://www.urbanfireplaces.com)  
NOV 2023  
C-16923