

ITEM NO.	PART NUMBER	DESCRIPTION	QTY.	REVISION	MATERIAL
1	DRSQT38002-20	BOTTOM TRIM	1	A	SATIN/22
2	DRSQT38001-20	TOP TRIM	1	B	SATIN/22
3	DRSQT002-20	SIDE TRIM	2	B	SATIN/22

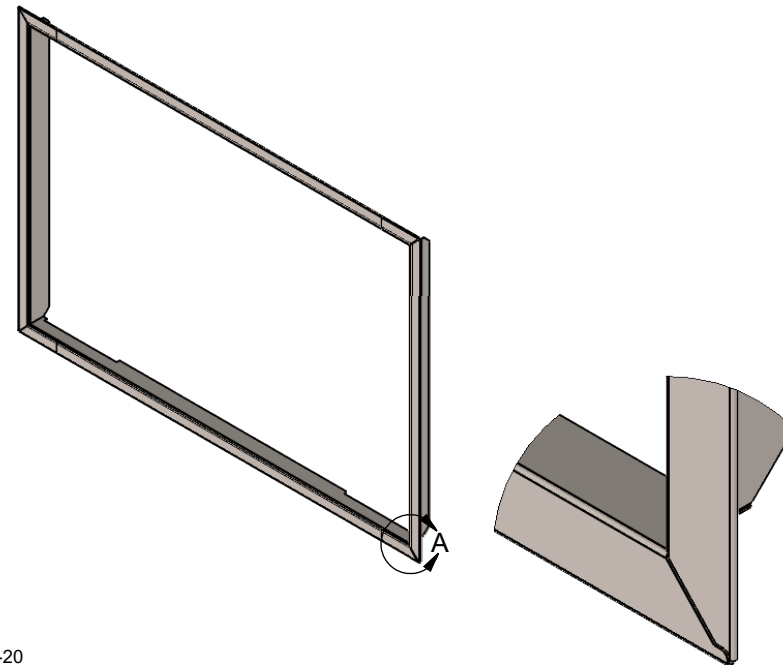

DETAIL A  
SCALE 1 : 2

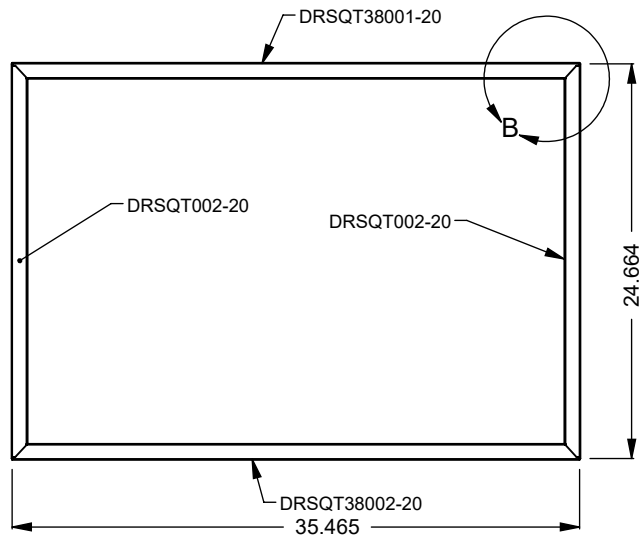
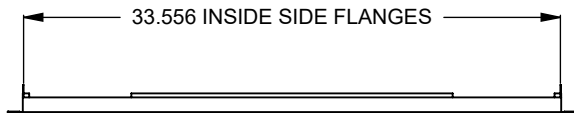
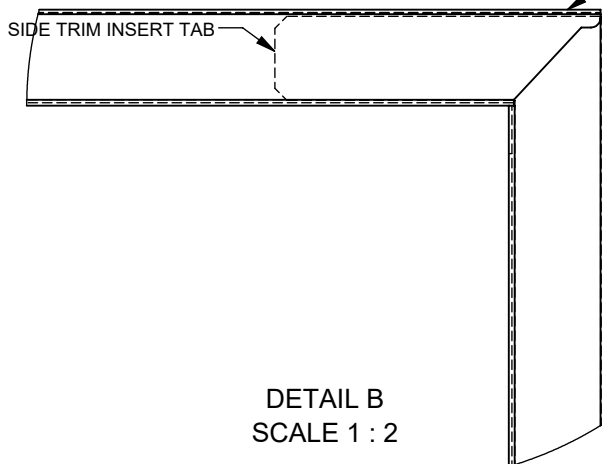

DETAIL B  
SCALE 1 : 2

DIMENSIONS ARE IN INCHES  
TOLERANCES:  
FRACTIONAL  $\pm 1/32"$   
TWO PLACE DECIMAL  $\pm .015"$   
THREE PLACE DECIMAL  $\pm .005"$   
ALL BENDS ARE ASSUMED TO BE 90° UNLESS NOTED OTHERWISE.

	NAME	DATE
DRAWN BY	DB	3/23/2020
CHECKED BY		
MATERIAL	MTK	
K-FACTOR		

DRSQ38 0-.6875in TRIM FRAME ASSY  
DRSQ38 0-.6875in TRIM FRAME ASSY

**MONTIGO**  
the art of fireplaces

SIZE	DWG. NO.	REV.
A	DRSQ38 .6875in TRIM FRAME ASSY	A
SCALE 1:12	WEIGHT:	SHEET 1 OF 2