

E40 ELECTRIC FIREPLACE



European Home

Manufacturer and Importer of high-end Gas, Wood and Electric Fireplaces

evonicfires

Award-winning designs
imported from the UK



SPECIFICATIONS

FUEL TYPE	Powered by Electricity
POWER SUPPLY	15 Amp, 120 Volt Circuit
FLAME EFFECT	EvoFlame UltraHD
VIEWABLE OPENING	39 ½" W x 13 ¼" H
HEAT OUTPUT	3,400 - 6,800 BTU/hr
CONFIGURATIONS	3-Sided Corner Style Single-Sided
WEIGHT	74 lbs.
VENTING	N/A
INTERIOR	Mirrored Glass
REMOTE CONTROL	E-touch App Control
CERTIFICATION	UL E54813, UL E228455, UL E140692

PRODUCT OPTIONS & ACCESSORIES

evoflame[®]
ULTRAHD

- An LED flame animation projected onto a mirrored background.
- Along the front is a flickering light that is projected across the logs.
- There are lights projected down from the top of the unit to further illuminate the logs.
- The bed is made of chrome with vermiculite glued to it. This surface reflects the flickering lights to give the illusion that it is coming from under the logs.
- Models have an anti-reflective glass front.
- This surface is 70% less reflective and gives the illusion that there is no front glass.
- Can connect to your device through Bluetooth.
- Each unit has a heater with an adjustable thermostat.

ALL E SERIES ELECTRIC FIREPLACES SHIP AS A 3-SIDED MODEL WITH A CONVERSION KIT TO EASILY TRANSFORM IT INTO A CORNER STYLE OR SINGLE-SIDED UNIT.

FIREPLACE MODEL

PRODUCT	ITEM CODE
E40	EV-FP-ESER-40

OPTIONAL ACCESSORIES

PRODUCT	ITEM CODE
E TABLET	EV-ES-TAB

FIRE MEDIA



WOODLAND

PRODUCT	ITEM CODE
WOODLAND LOG SET	MDL-FM-WD-01

CUT SHEET

E40 3-SIDED

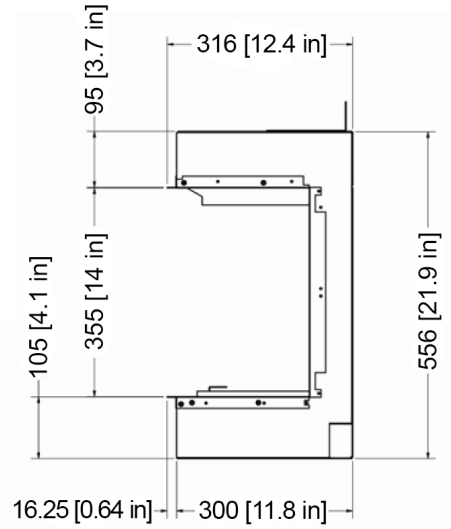
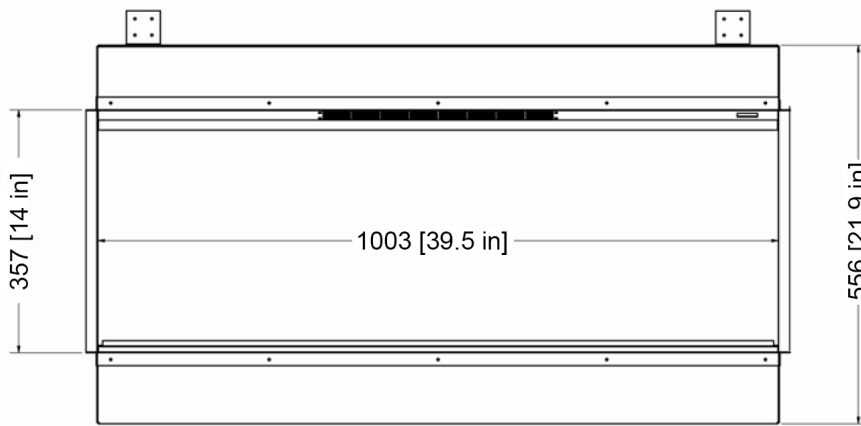
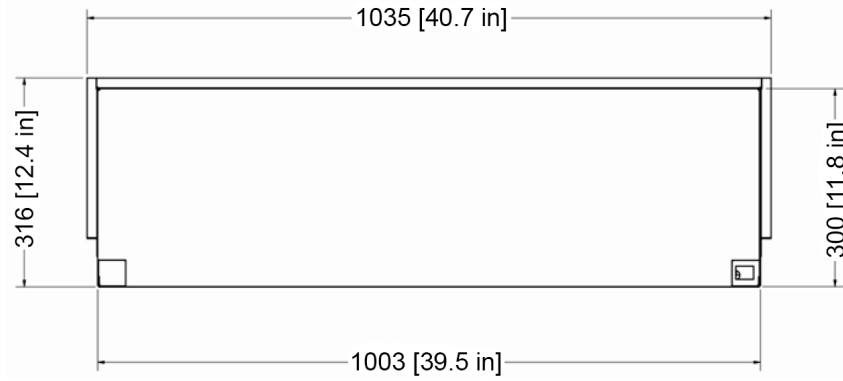

MODEL	HEIGHT	WIDTH	DEPTH
E40	21 7/8"	39 9/16"	11 13/16"
	556mm	1005mm	300mm

BOXED WEIGHT	UNBOXED WEIGHT
44KG (97lbs)	33.55KG (74lbs)

CUT SHEET

E40 CORNER STYLE

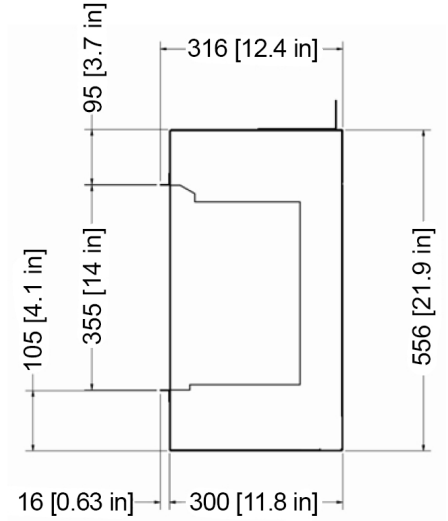
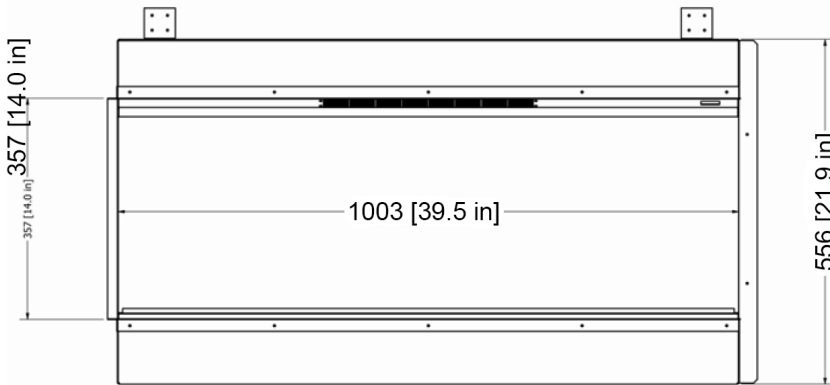
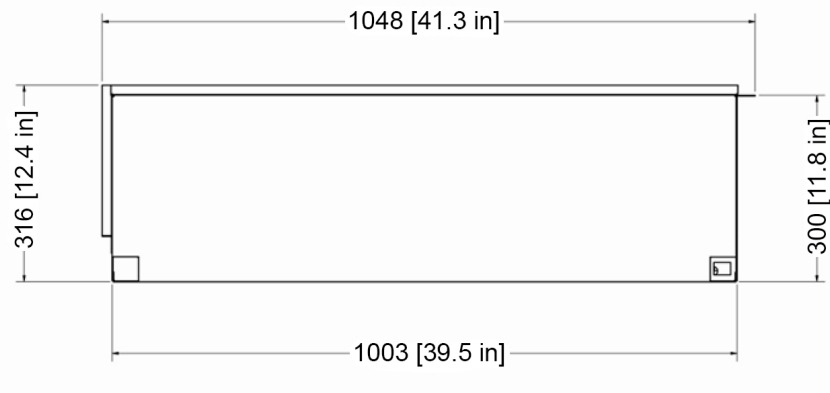

MODEL	HEIGHT	WIDTH	DEPTH
E40	21 7/8"	39 9/16"	11 13/16"
	556mm	1005mm	300mm

BOXED WEIGHT	UNBOXED WEIGHT
44KG (97lbs)	33.55KG (74lbs)

CUT SHEET

E40 SINGLE-SIDED

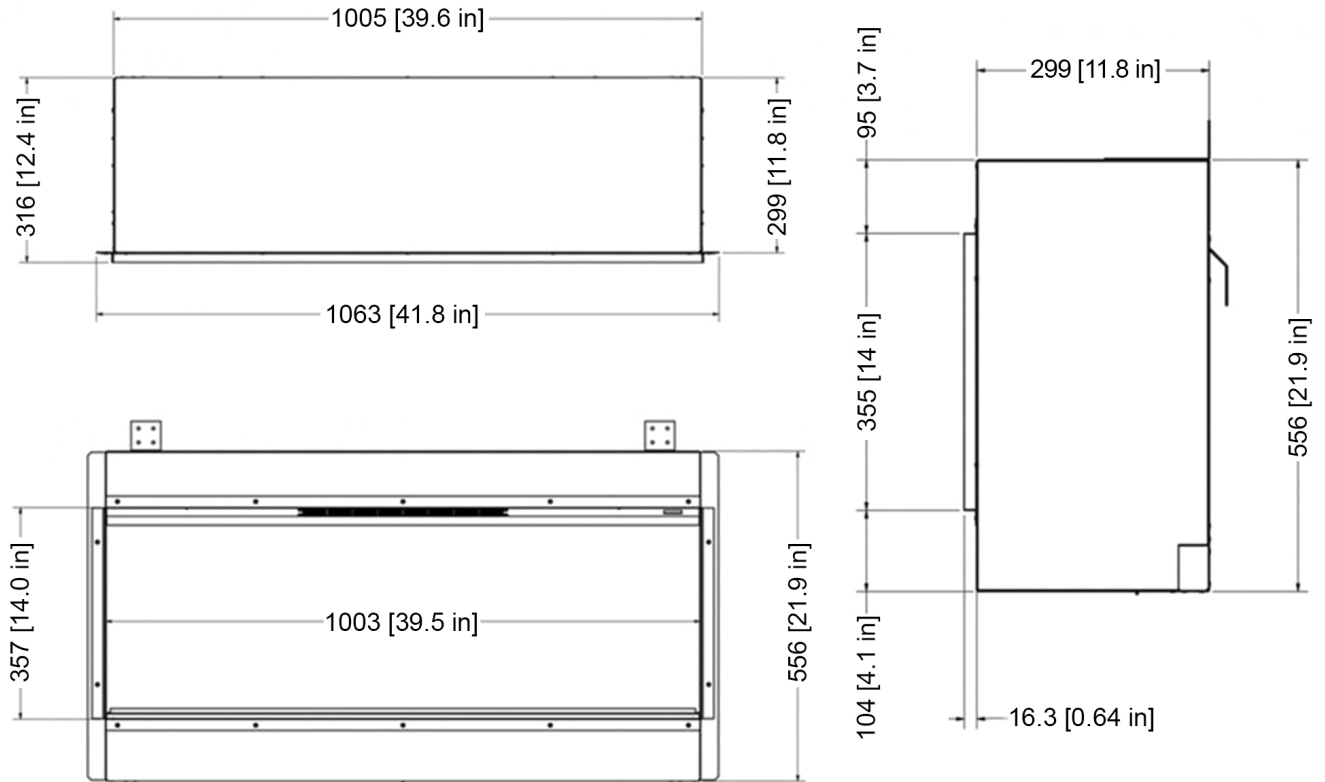

MODEL	HEIGHT	WIDTH	DEPTH
E40	21 7/8"	39 9/16"	11 13/16"
	556mm	1005mm	300mm

BOXED WEIGHT	UNBOXED WEIGHT
44KG (97lbs)	33.55KG (74lbs)