

# URBANA

LUXURY FIREPLACES

## U50 / U70

INSTALLATION MANUAL

For Models: U50I-LP / U50I-LP-LED / U50I-NG / U50I-NG-LED / U70I-LP / U70I-LP-LED / U70I-NG / U70I-NG-LED

**WARNING:** If the information in this manual is not followed exactly, a fire or explosion may result causing property damage, personal injury or loss of life. Installation and service must be performed by a qualified installer, service agency or the gas supplier.

CERTIFIED TO: ANSI Z21.88 / CSA 2.33 VENTED GAS FIREPLACE HEATERS  
CSA 2.17 GAS FIRED APPLIANCES FOR HIGH ALTITUDES

C-15883



**Intertek**  
C#4001609

Retain this manual for future reference.

**WARNING:**

**FIRE OR EXPLOSION HAZARD**

Failure to follow safety warnings exactly could result in serious injury, death, or property damage.

- Do not store or use gasoline or other flammable vapours and liquids in the vicinity of this or any other appliance.
- **WHAT TO DO IF YOU SMELL GAS**
  - Do not try to light any appliance.
  - Do not touch any electrical switch; do not use any phone in your building.
  - Leave the building immediately.
  - Immediately call your gas supplier from a neighbor's phone. Follow the gas supplier's instructions.
  - If you cannot reach your gas supplier, call the fire department.
- Installation and service must be performed by a qualified installer, service agency or the gas supplier.

This appliance is only for use with the type of gas indicated on the rating plate. This appliance is not convertible for use with other gases.

Massachusetts installations (Warning): This product must be installed by a licensed plumber or gas fitter when installed within the Commonwealth of Massachusetts. Other Massachusetts code requirements: Flexible connector must not be longer than 36in., a shut off valve must be installed; only direct vent sealed combustion products are approved for bedrooms/bathrooms. A carbon monoxide detector is required in all rooms containing gas fired direct vent appliances. The fireplace damper must be removed or welded in the open position prior to installation of a fireplace insert.

- All Urbana gas-fired appliances must be installed in accordance with their instructions. Carefully read all the instructions in this manual first. Consult the building authority having jurisdiction to determine the need for a permit prior to commencing the installation.
- **WARNING:** Failure to follow these instructions could cause a malfunction of the fireplace, which could result in death, serious bodily injury, and/or property damage.
- Failure to follow these instructions may also void your fire insurance and/or warranty.
- Installation and repair should be done by a qualified service person. The appliance should be inspected before the first use and, at least, annually by a qualified service person. More frequent cleaning may be required due to excessive lint from carpeting, bedding material, etc. It is imperative that the control compartments, burners and circulating air passageways of the appliance be kept clean.
- Due to high temperatures, the appliance should be located out of high traffic areas and away from furniture and draperies.
- Children and adults should be alerted to the hazards of high surface temperatures and should stay away to avoid injury.
- Young children should be carefully supervised when in the same room as the appliance. Toddlers, young children and others may be susceptible to accidental contact burns. A physical barrier is required if there is a risk for individuals in the house. To restrict access to a fireplace or stove, install an adjustable safety gate to keep toddlers, young children and other at risk individuals out of the room and away from hot surfaces. Any safety screen, guard, or barrier removed for servicing an appliance must be replaced prior to operating the appliance.
- Clothing or other flammable materials should not be placed on or near the appliance.
- A barrier designed to reduce the risk of burns from the hot viewing glass is provided with this appliance and shall be installed for the protection of children and other at-risk individuals. If the barrier becomes damaged, the barrier shall be replaced with the manufacturer's barrier for this appliance.

## FOR YOUR SAFETY

- Installation and service must be performed by a qualified installer, service agency, or gas supplier.
- This installation must conform to local codes or, in the absence of local codes, with the National Fuel Gas Code, ANSI Z223.1/NFPA 54, or the Natural Gas and Propane Installation Code, CSA B149.1.
- To prevent injury, do not allow anyone who is unfamiliar with the fireplace to operate it.
- To prevent injury, if the pilot or pilot and burners have gone out on their own, wait 5 minutes to air out before attempting to re-light the appliance.
- Always keep the area around these appliances clear of combustible material, gasoline and other flammable liquids or vapours.
- These appliances should not be used as a drying rack for clothing or for hanging Christmas stockings/decorations.
- Due to the paint curing on the unit, a faint odor and slight smoking will likely be noticed when the stove is first used. Open some windows until the smoking stops.
- Always connect this gas appliance to a vent system and vent to the outside of the building envelope. Never vent to another room or inside the building. Make sure the specified vent pipe is used, properly sized and of adequate height to provide sufficient draft. Inspect the venting system annually for blockage and signs of deterioration.
- **WARNING:** Failure to position the parts in accordance with the diagrams in this booklet, or failure to use only parts specifically approved with this appliance, may result in property damage or personal injury.
- **WARNING:** Do not operate with the glass front removed, cracked, or broken. Replacement of the glass should be done by a licensed or qualified service person.
- Never use solid fuels such as wood, paper, cardboard, coal, or any flammable liquids, etc., in this appliance.
- Do not use this appliance if any part has been under water. Immediately call a qualified service technician to inspect the appliance and to replace any part of the control system or any gas control which has been under water.
- Do not abuse the glass by striking it or slamming the door shut. If the Urbana unit is pulled out of its installation, and the vent-air intake system is disconnected for any reason, ensure that the vent-air intake pipes are reconnected and re-sealed in accordance to the instructions noted in Initial Installation - Direct Vent

DANGER



**HOT GLASS WILL  
CAUSE BURNS**

**DO NOT TOUCH GLASS  
UNTIL COOLED.**

**NEVER ALLOW CHILDREN  
TO TOUCH GLASS.**

A barrier designed to reduce the risk of burns from the hot viewing glass is provided with this appliance and shall be installed for the protection of children and other at-risk individuals.

**DIRECT VENT ONLY:** This type is identified by the suffix DV. This appliance draws all of its air for combustion from outside the dwelling, through a specially designed vent pipe system.

This appliance has been tested and approved for installations from 0 feet to 4500 feet (1372 m) above sea level.

**In the USA:** The appliance may be installed at higher altitudes. Please refer to your American Gas Association guidelines which state: the sea level rated input of Gas Designed Appliances installed at elevations above 2000 (610 m) feet is to be reduced 4% for each 1000 feet (305 m) above sea level. Refer also to local authorities or codes which have jurisdiction in your area regarding the de-rate guidelines.

**In Canada:** When the appliance is installed at elevations above 4500 feet (1372 m), the certified high altitude rating shall be reduced at the rate of 4% for each additional 1000 feet (305 m).

- This appliance has been tested by INTERTEK and found to comply with the established VENTED GAS FIREPLACE HEATER standards in CANADA and the USA as follows:

### **VENTED GAS FIREPLACE HEATER (U50 & U70; NATURAL GAS, PROPANE GAS)**

CERTIFIED TO: ANSI Z21.88 / CSA 2.33 VENTED GAS FIREPLACE HEATERS

CSA 2.17 GAS FIRED APPLIANCES FOR HIGH ALTITUDES

#### **This Urbana Fireplace:**

- Has been certified for use with either natural gas or propane (see rating label).
- Is not for use with solid fuels.
- Is approved for a bedroom or bed sitting room. (**IN CANADA:** must be installed with a listed wall thermostat.  
**IN USA:** see current ANSI Z223.1 for installation instructions.)
- Must be installed in accordance with local codes. If none exist, use current installation code CAN/CGA B149.1 in Canada or ANSI Z223.1/NFPA 54 in the USA.
- Must be properly connected to an approved venting system and not connected to a chimney flue serving a separate solid-fuel burning appliance.

**IMPORTANT NOTICE (Regarding first fire up):** When the unit is turned on for the first time, it should be turned onto high for the first 4 hours. This will cure the paint, logs, gasket material and other products used in the manufacturing process. It is advisable to open a window or door, as the unit will start to smoke and can irritate some people. After the unit has gone through the first burn, turn the unit off including the pilot, let the unit get cold then remove the glass door and clean it with a good gas fireplace glass cleaner, available at your local URBANA dealer.

**NATIONAL  
FIREPLACE  
INSTITUTE**



**CERTIFIED**

[www.nficertified.org](http://www.nficertified.org)

We recommend that our gas hearth products be installed and serviced by professionals who are certified in the U.S. by the National Fireplace Institute® (NFI) as NFI Gas Specialists.

**Unpacking and Initial Setup 9**

Crate Unpacking ..... 8  
Glass Shipping Brace Removal..... 9  
Pallet Bracket Removal ..... 9  
Lift Handle Assembly ..... 9  
Heat Shield Installation ..... 10  
Leg Height Adjustment ..... 10  
Fireplace Leveling ..... 11  
Electrical Connection ..... 11  
Gas Connection ..... 12  
Gas Supply Varification ..... 14  
Valve Access ..... 14

**Maintenance and Service 15**

Fan Removal and Maintenance ..... 15  
Sail Switch Removal and Maintenance ..... 16  
Component Tray Map ..... 17  
Replacing Fuses - Fan and Top Light ..... 17  
Snap Disc ..... 17  
Pilot Light ..... 18  
Air Shutter (Venturi) ..... 18  
Remote Syncing ..... 19  
Power Vent (PV) Switch ..... 19  
Top Light Replacement ..... 20  
Burner Removal ..... 20  
Safety Circuit System ..... 21  
Safety Circuit Components ..... 21  
Outer Glass Removal ..... 22  
Louver Removal ..... 23  
Inner Glass Removal ..... 24  
Media Placement ..... 25  
Final Firebox Sealing ..... 26

**Framing and Installation 27**

Chase Framing ..... 27  
Framing Air Gaps ..... 27  
Framing Options ..... 27  
Minimum Framing Clearances ..... 28  
Framing Pedestal ..... 32  
Framing Valance ..... 32  
Framing Corner and Extension ..... 34  
Crawl Space / Basement Intake ..... 35  
HDTV and Recess Clearances ..... 36  
Finishing Fascia (Optional) ..... 37

**Venting 38**

Venting Introduction ..... 38  
Vent Termination Restrictions ..... 39

Vertical Termination ..... 40  
Venting Clearances ..... 42  
Approved Rigid Venting ..... 43  
Flex Venting ..... 44  
Approved Venting Configurations ..... 45  
Exhaust Restrictor Setting: ..... 47

**Parts List 48**  
**Troubleshooting 51**  
**Wiring Diagram 53**  
**Warranty 54**

# URBANA

## LUXURY FIREPLACES

### Unit Dimensions

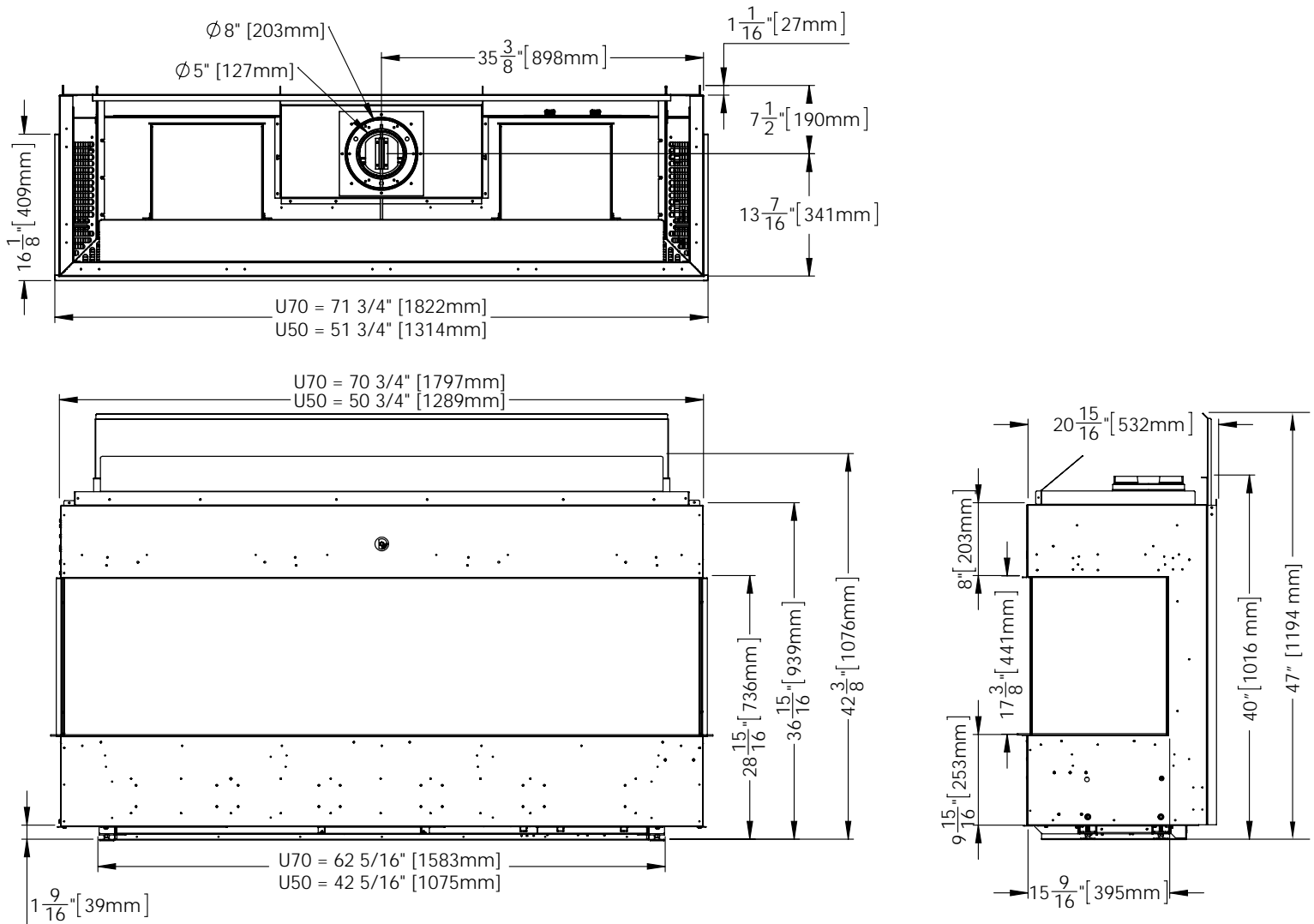

### Rating Label Location

Remove the outer glass barrier to access the rating label and lighting instructions. The label is attached to a length of wire and is never to be tampered with or removed. All important information for your fireplace is on this label such as the model specific serial number which you will need for warranty information. The label is located inside the front right corner of the cabinet behind the cooling fan.

**For Your Safety, Read Safety Precautions And  
Lighting Instructions Before Operating**

**WARNING: IF YOU DO NOT FOLLOW THESE INSTRUCTIONS EXACTLY THEN A  
FIRE OR EXPLOSION MAY RESULT, CAUSING PROPERTY DAMAGE, PERSONAL  
INJURY OR LOSS OF LIFE.**

**FOR YOUR SAFETY READ BEFORE OPERATING**

**WARNING: IF YOU DO NOT FOLLOW THESE INSTRUCTIONS EXACTLY, A FIRE OR EXPLOSION  
MAY RESULT CAUSING PROPERTY DAMAGE, PERSONAL INJURY OR LOSS OF LIFE.**

- A. This appliance is equipped with an ignition device which automatically lights the pilot. Do not try to light the pilot by hand.
- B. BEFORE OPERATING smell all around the appliance area for gas. Be sure to smell next to the floor because some gas is heavier than air and will settle on the floor.
- WHAT TO DO IF YOU SMELL GAS:
- Do not try to light any appliance.
  - Do not touch any electrical switch; do not use any phone in your building.
  - Immediately call your gas supplier from a neighbor's phone. Follow the gas supplier's instructions.
  - If you cannot reach your gas supplier, call the fire department.
- C. Use only your hand to push in or turn the gas control knob. Never use tools. If the knob will not push in or turn by hand, don't try to repair it, call a qualified service technician. Force or attempted repair may result in a fire or explosion.
- D. Do not use this appliance if any part has been under water. Immediately call a qualified service technician to inspect the appliance and to replace any part of the control system and any gas control which has been under water.

**OPERATING INSTRUCTIONS**

1. STOP! Read the safety information above on this label.
2. Read the owner's manual including the section on "Remote Control" operation.
3. Set the thermostat to the lowest setting.
4. Turn off all electric power to the appliance.
5. Do not attempt to light the pilot by hand.
6. Wait five (5) minutes to clear out any gas. Then smell for gas, including near the floor. If you smell gas, STOP! Follow "B" in the safety information above on this label. If you don't smell gas, go to the next step.
7. Turn on all electric power to the appliance.
8. Using the remote control, set thermostat to desired setting, or press the ON/OFF key on the remote. "ON" will be indicated on the display of the remote and an audible "beep" will be heard at the unit to indicate the command has been received.
9. This appliance is equipped with a completely automatic ignition and lighting control. The control will attempt to light the pilot several times if necessary. If it is unsuccessful, it will discontinue operations. If the appliance will not operate, follow the instructions "To Turn Off Gas To Appliance" and call your service technician or gas supplier.

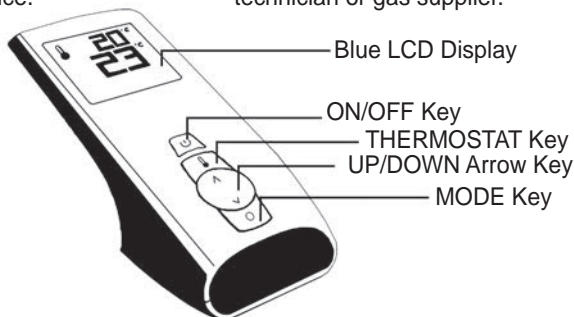

**TO TURN OFF GAS TO APPLIANCE**

1. Set thermostat to lowest setting, or press the ON/OFF Key. "OFF" will be indicated on the display and an audible "Beep" will be heard at the unit to indicate the command has been received.
2. Turn off all electric power to the appliance if service is to be performed.

C-12455

#### Crate Unpacking

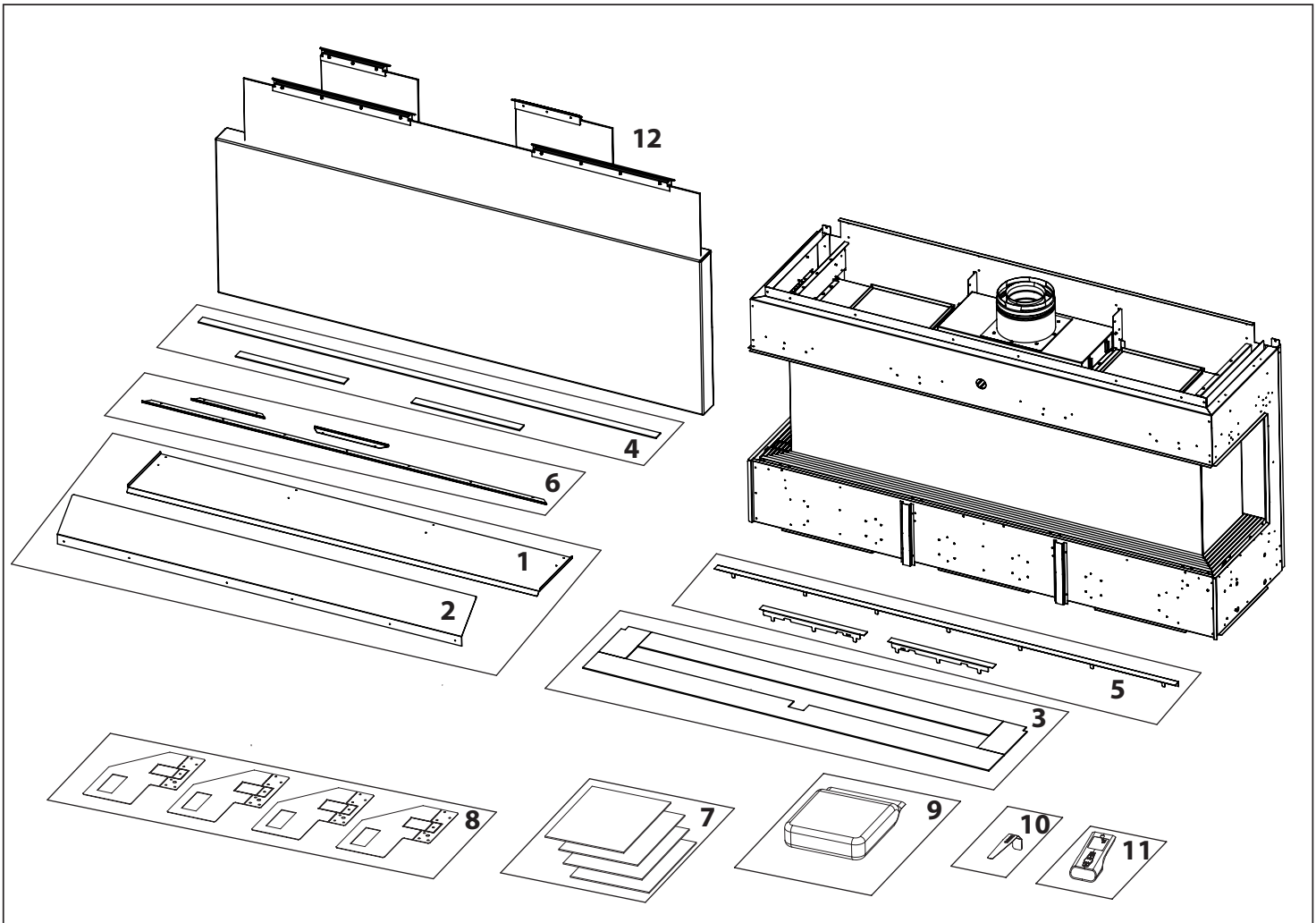

#### Unpacking parts

|   |   |   |  |    |  |                                       |
|---|---|---|--|----|--|---------------------------------------|
| 1 | Back Heat Deflector                               | 5 | Finishing Edges  | 9  | Vermiculite Media <sup>2</sup><br>(Non-LED units only) | Clear Glass Media<br>(LED units only) |
| 2 | Front Heat Deflector                              | 6 | Media stops <sup>1</sup><br>(Optional for Non-LED units) | 10 | Switch tool  |                                       |
| 3 | Painted Steel bezel set<br>(Non-LED units only)   | 7 | Documentation  | 11 | WIFI Enabled Remote Control                            |                                       |
| 4 | Steel Fascia <sup>3</sup> (Installation optional) | 8 | Carrying handles   | 12 | Outside Glass  |                                       |

1 - Media stops only required on Non-LED units if an optional media is used instead of the painted steel bezel set. Media stops come pre-installed on LED units.

2 - U50 Non-LED units supplied with 3 bags of vermiculite. U70 Non-LED models supplied with 4 bags of vermiculite.

3 - Optional 3 piece fascia for the perimeter of the outer glass. Refer to page 37 for more details.



## Glass Shipping Brace Removal

The unit comes with glass shipping brackets to protect the glass while in transit. The brackets need to be removed before installation.

Use a 1/4 socket to remove the fasteners holding brackets on and discard.

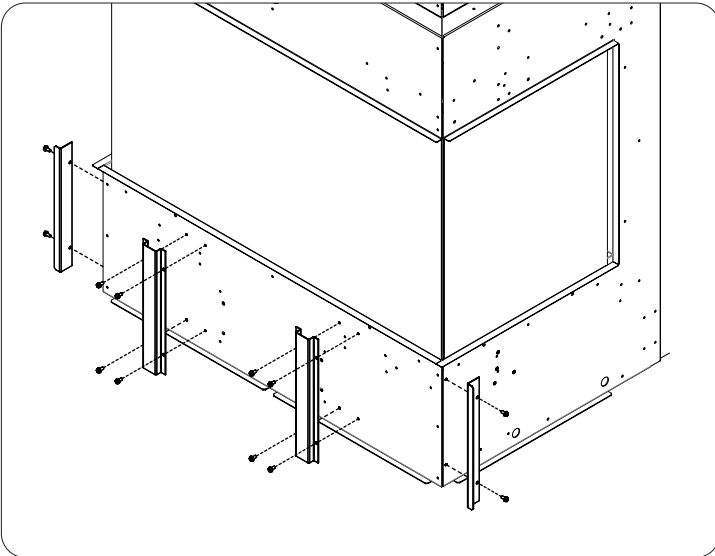

## Pallet Bracket Removal

Use a 5/16" socket to remove the pallet brackets on both sides of the unit. These can be discarded.

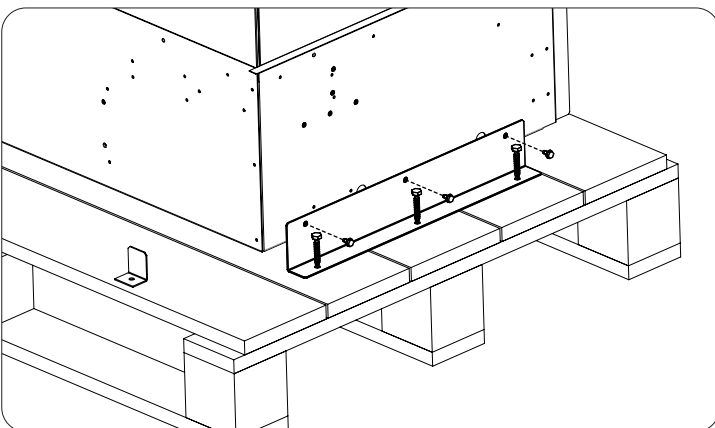

## Lift Handle Assembly

The lifting handles come attached to the unit. You will need to assemble the brackets using the bend tabs in order to lift the unit into place. The handles have been designed to be used with 2X4 lumber. Assemble as follows:

1. Cut two 2X4 no shorter than 18" (this is the minimum distance needed to safely span both handles).
2. Bend support leg into position (**labelled A**).

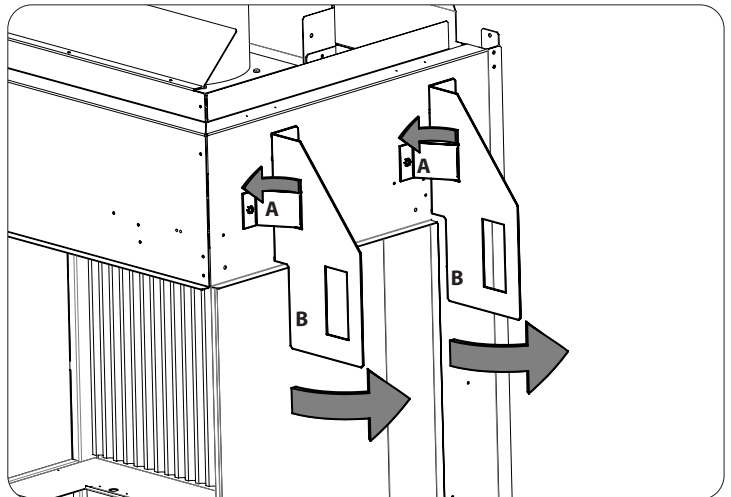

3. Bend handles perpendicular to fireplace as shown in image above (**labelled B**)
4. Use a 5/16 socket to remove lone fastener
5. Line up the support leg hole and secure with lone fastener (**Labelled A**).

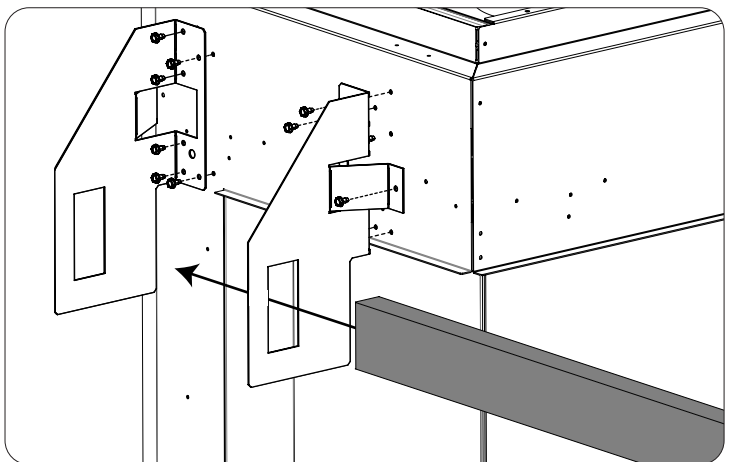

6. Slide 2X4 through handles on each side to create a strong lifting point.
7. Move U30 into position. Remove handles and discard.

### Heat Shield Installation

The fireplace comes with two heat shields that are necessary for the safe functioning of the fireplace. **Both heat shields must be attached to the cabinet of the fireplace prior to installation. These heat shields are MANDATORY.**

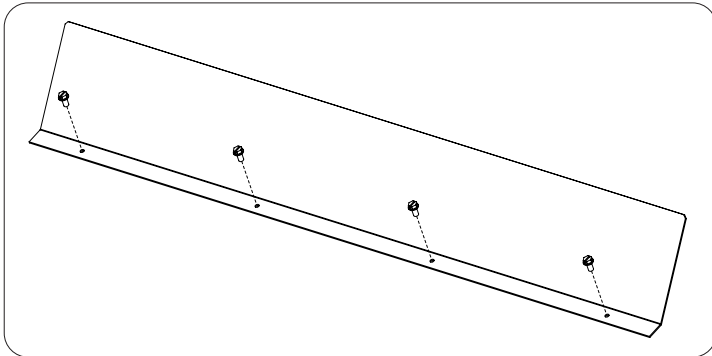

**1.** The fasteners (6 total) needed to install the front heat shield come installed on the shield itself; use a 1/4" socket to remove the fasteners.

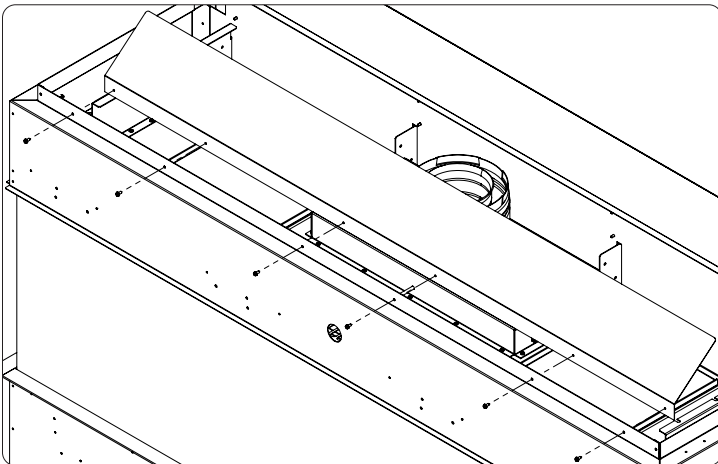

**2.** The front heat shield installs behind the top lip of the cabinet. Use the fasteners to screw through the cabinet and into the heat shield as shown.

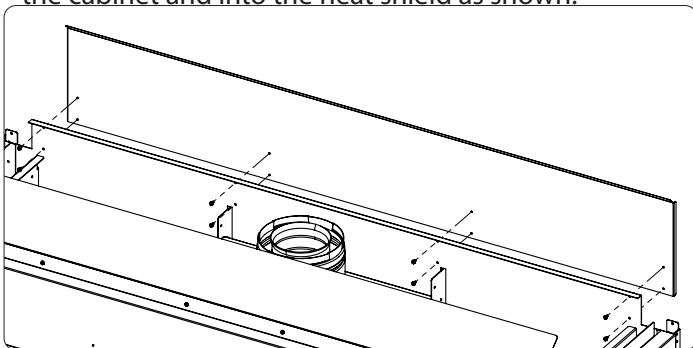

**3.** The rear heat shield installs on the cabinet back using 8 pre-installed screws. Use a 1/4" socket to remove the fasteners from the shield and mount the heat shield onto the back as shown.

### Leg Height Adjustment

(Optional) Urbana units have adjustable legs that can raise the height, in 1/2" increments, up to an additional 3" (76mm). This may be desired depending on the install configuration. Adjust as follows:

**1.** With help, gently lay the unit on its

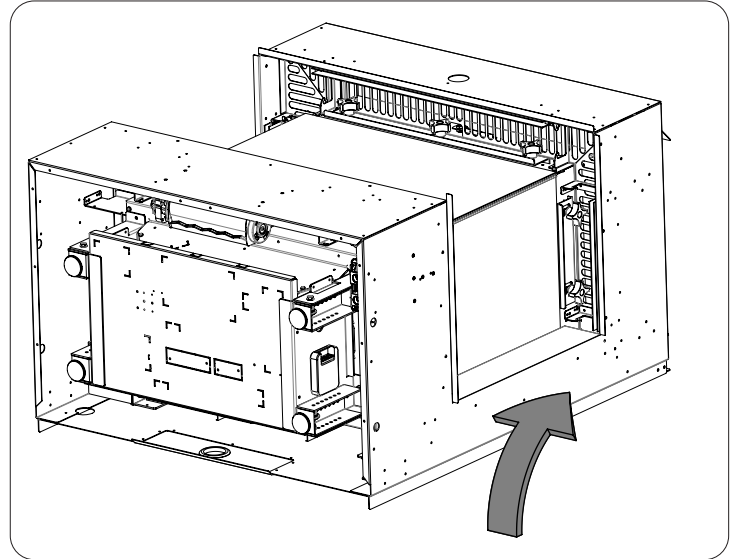

back to access the adjustable legs.

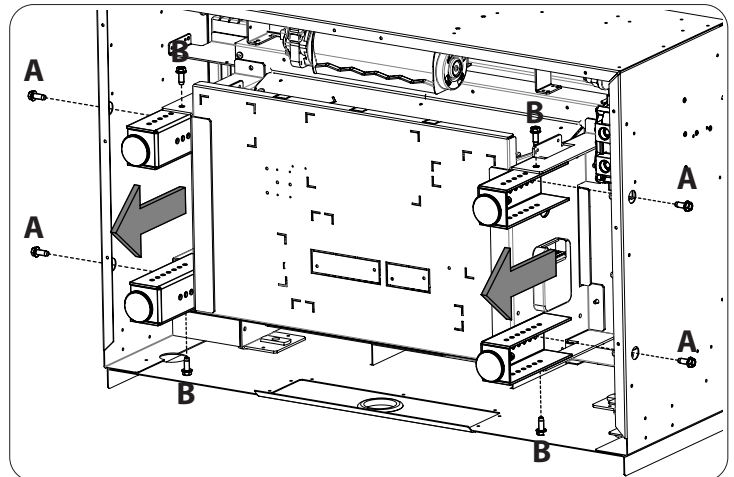

**2.** Use a 3/8 socket with 6" extension (minimum) to access fasteners. Remove side fasteners (Labelled A).

**3.** Remove end fasteners (Labeled B)

**4.** Adjust legs to desired height ensuring all 4 legs are equal. Legs adjust in 1/2" increments.

**5.** Reinstall fasteners and bring unit to its feet.

## Fireplace Leveling

### NOTES:

- 1: It is essential to level the unit from proper operation.
- 2: This step is not necessary when wall mounting unit.

All Urbana units come with leveling feet to accommodate uneven surfaces. The leveling feet can also be used to raise the height of the fireplace up an additional 1" (25 mm). Ensure the fireplace is in its final position before proceeding.

Leveling feet come fully inserted; you will need to unscrew the feet to see any adjustment (no lock nut used). Adjust as follows:

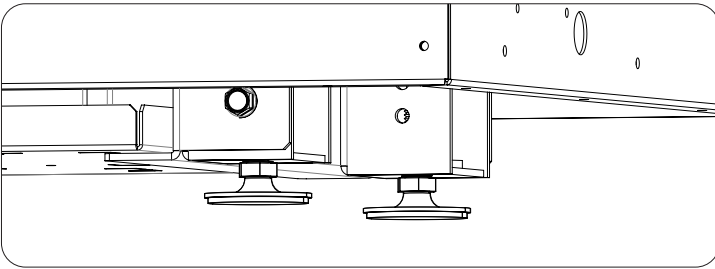

1. Use a level on the top of the unit to determine which feet need adjustment.
2. Use a 9/16 wrench to unscrew the feet to make the necessary adjustments.
3. Verify fireplace is level in all 3 planes.

## Electrical Connection

**WARNING: This fireplace must be electrically connected and grounded in accordance with local codes or, in the absence of local codes, with the current CSA C22.1 Canadian Electrical Code Part 1, Safety Standards For Electrical Installations, or The National Electrical Code ANSI / NFPA 70 in the US.**

### Electrical Requirements:

120VAC 15A (dedicated circuit recommended). Appliance receptacle must be hardwired with coated 14/2 AWG (minimum) copper electrical wire such as Lumex or Romex. Consult your electrical code for further details. Wire your unit as follows:

1. Run wire to left rear of unit (see below); be sure wire is NOT live.

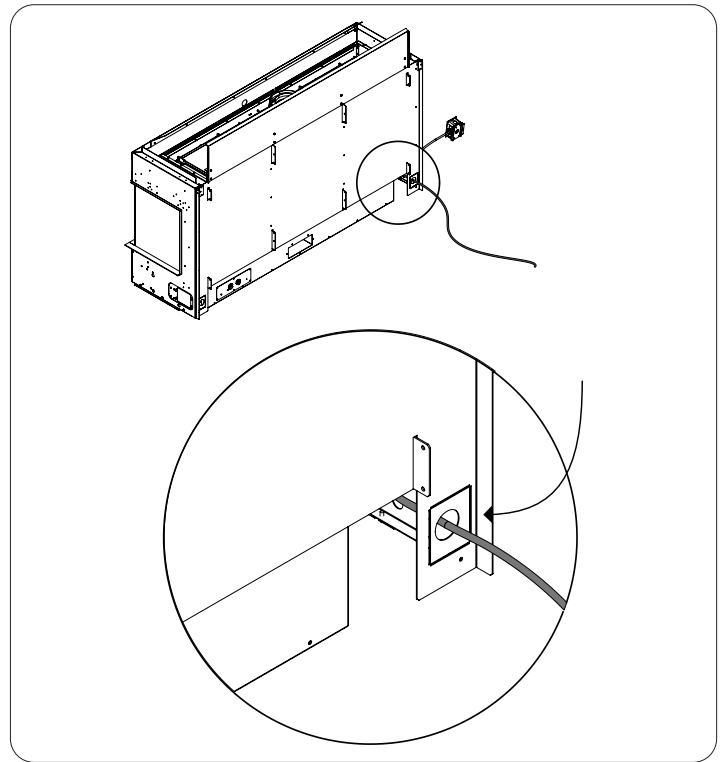

2. Remove the outer glass and left side louver (pages 22-23) and locate the electrical junction box.

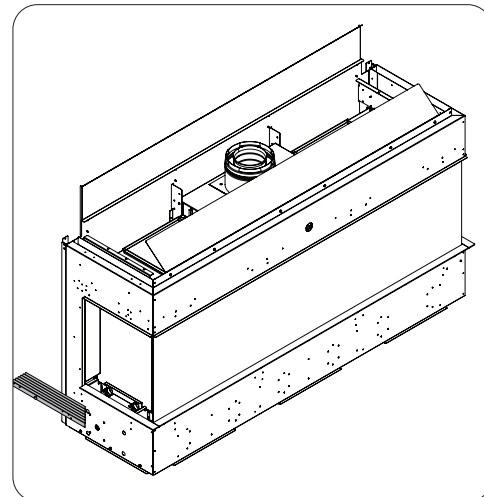
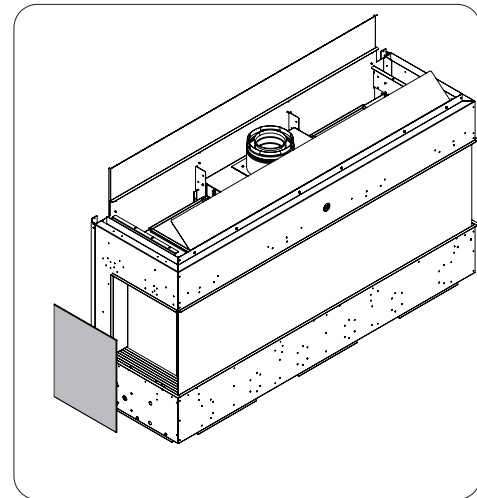

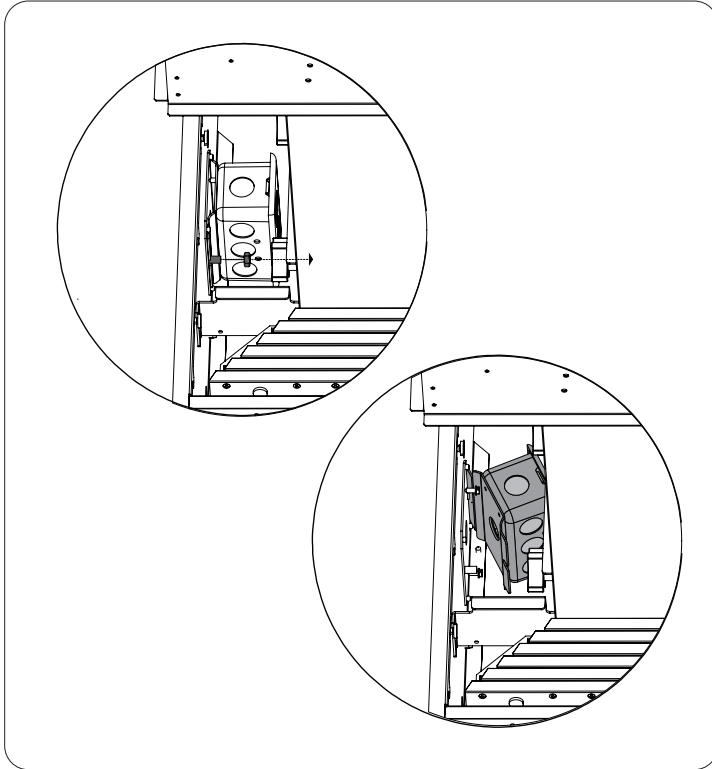

**3.** Use a 7/16" socket to remove the two 1/4-20 nuts retaining the electrical junction box and unplug the fireplace power cord from the receptacle.

**4.** Remove the junction box from the fireplace and run the incoming power wire through the desired knock-out and into the box.

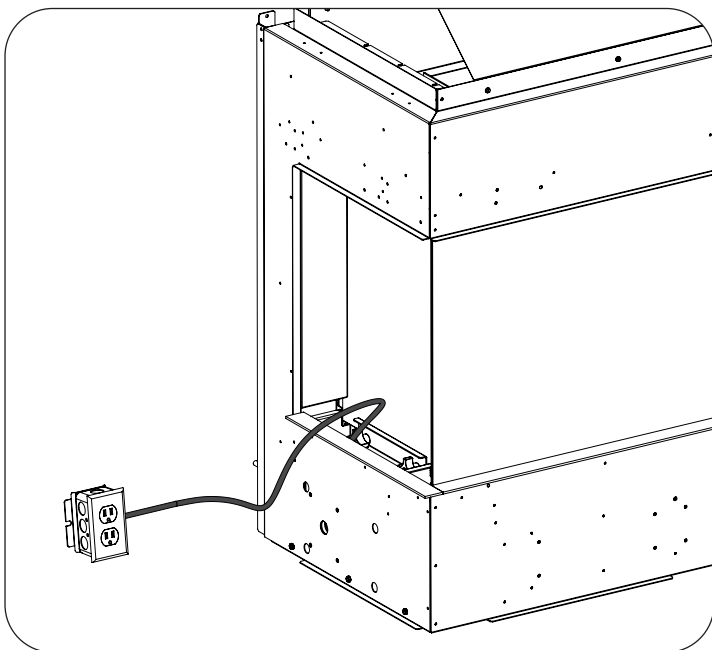

**5.** Wire the receptacle including ground wire.

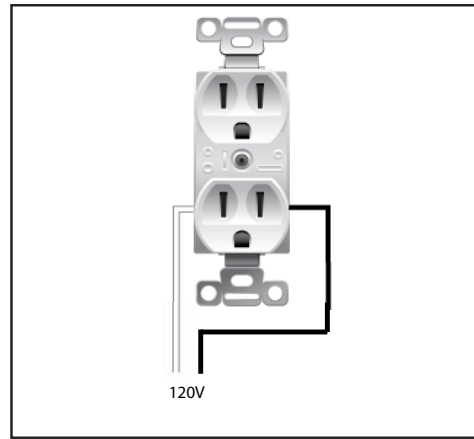

**6.** Plug the fireplace power cord back into the receptacle and re-install the junction box.

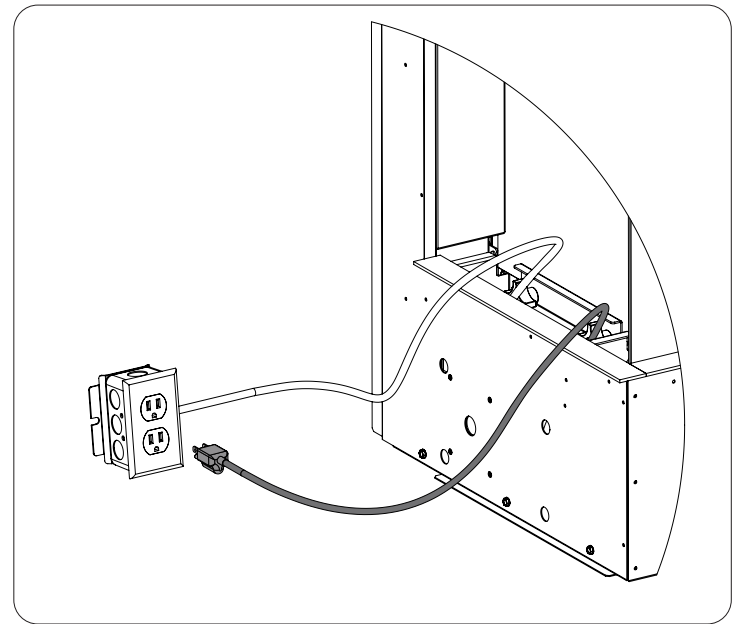

**7.** Apply power and ensure connection was made successfully.

### Gas Connection

**WARNING:**  
**ONLY PERSONS LICENSED TO WORK WITH GAS PIPING MAY MAKE THE NECESSARY GAS CONNECTIONS TO THIS APPLIANCE.**

**NOTE:**  
Consult your local authorities codes or the CAN/CGA B 149 (1 or 2) installation code in Canada, or in the USA gas installations follow either local codes or the current edition of the National Fuel Gas Code ANSI Z223.1.

1. Remove outer glass (see page 22).
2. Remove the right louver (see page 23) and locate the gas shut-off valve.
3. Ensure the valve is closed.

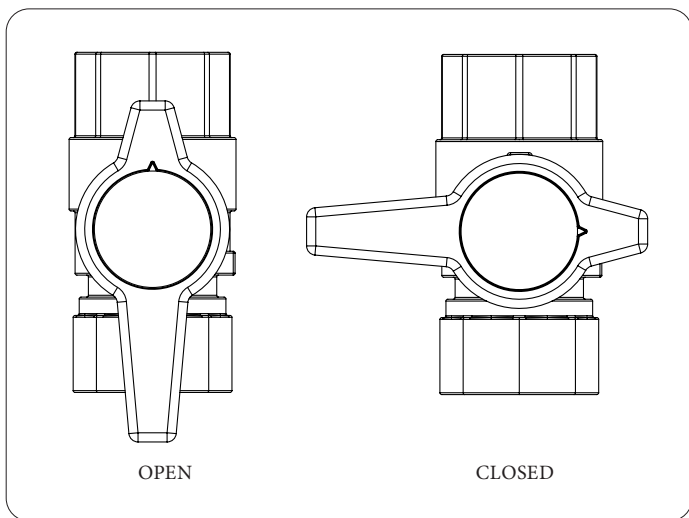
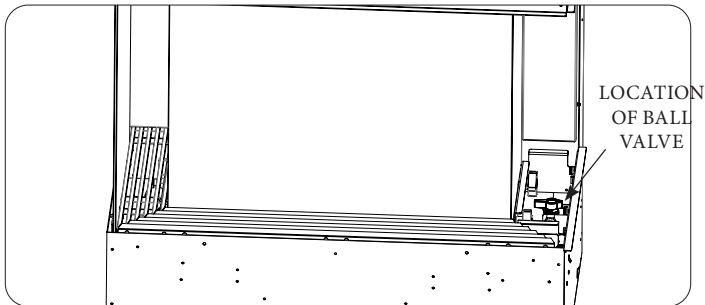

4. Next, locate the recessed access plate near the bottom of the right cabinet side and loosen the 4 screws using a T20 screwdriver.

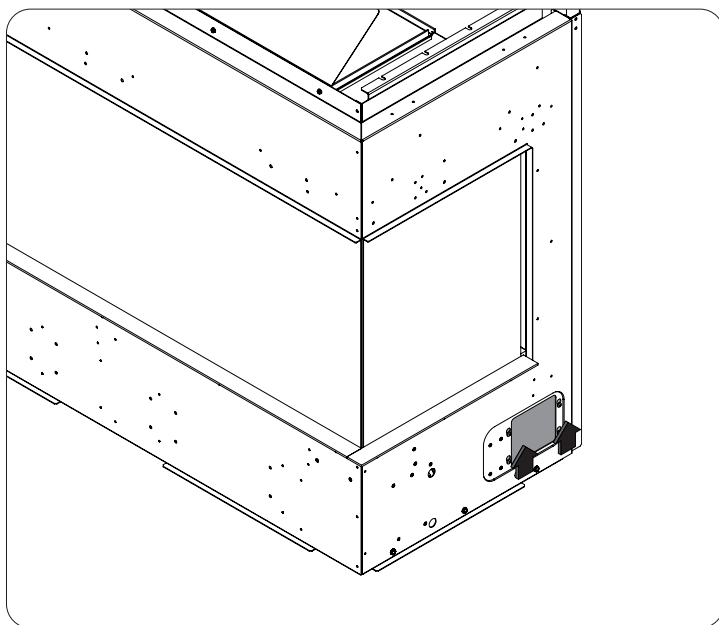

5. To remove the plate, lift it up off the key slots and tilt it inward and out through the opening.
6. Route the incoming gas line as desired and connect to the 1/2" NPT female fitting of the shut-off valve; use gas approved pipe sealant. Note, the access plate may be left off to allow for side entry of the incoming gas line.

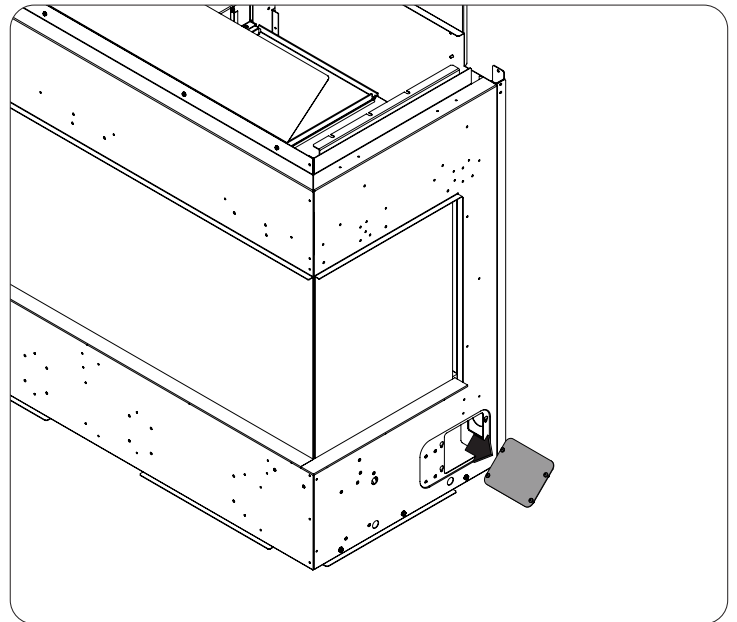

7. If use of a regulator is required the square knockout on the back of the fireplace may be removed for routing purposes and extra room.

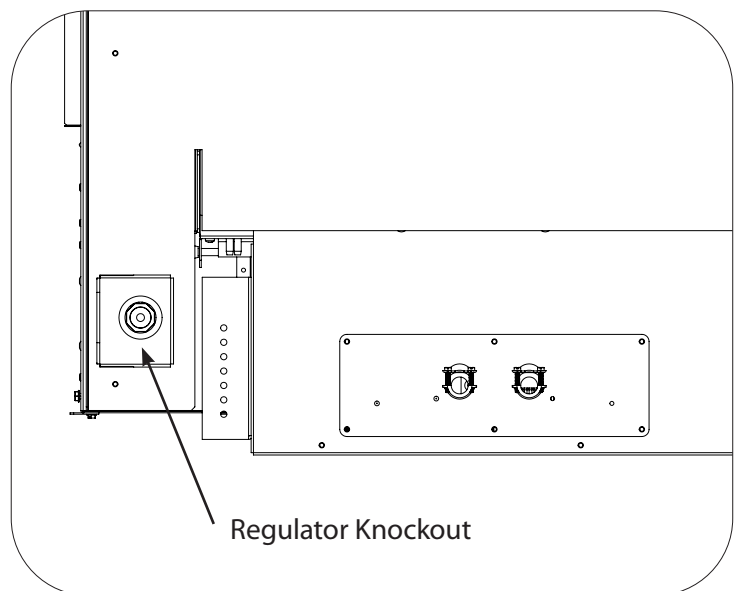

8. Open shut-off valve and check for leaks - NEVER USE AN OPEN FLAME!

### Gas Supply Verification

**NOTE:** Do not spray leak-testing liquid in pressure taps or results will not be accurate.

Ensure the appliance is seeing correct gas pressures and inputs. Verify the following information matches that of the rating label. Pressure taps are located on the valve (see image). A 5/16 (8mm) I.D. hose is required to make the connections. Check gas pressures as follows:

1. Open inlet pressure tap (half turn) and use a manometer to verify inlet pressure with unit running on HI. Pressure cannot exceed 1/2 PSIG (14" W.C.) or valve damage may occur. Adjust inlet pressure as needed and shut pressure tap.
2. Open manifold pressure tap (half turn) and connect manometer. Verify gas pressures are within range while unit is running on HI and LO. Release manometer and shut pressure tap. **Contact your dealer if proper pressures cannot be achieved.**

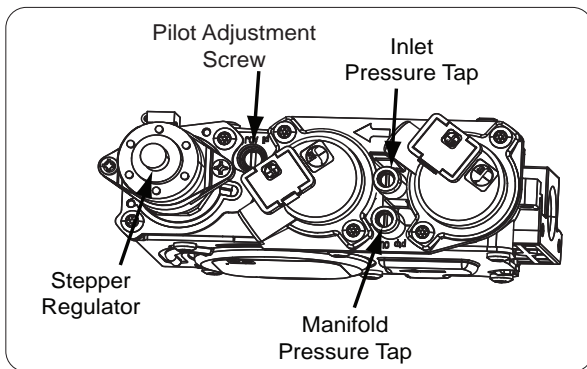

**Note** - The fireplace must be isolated from the gas supply piping system by closing its equipment shut-off valve during any pressure testing of that system at test pressures in excess of 1/2 psi (3.5 kPa).

| Natural Gas            |                         |
|------------------------|-------------------------|
| Main Orifice           | #32 (U50) / #28 (U70)   |
| Manifold Pressure      | 3.5" W.C. (0.89 KPa)    |
| Min. Manifold Pressure | 1.6" W.C. (0.39 KPa)    |
| Max Supply Pressure    | 7.0" W.C. (1.74 KPa)    |
| Min. Supply Pressure   | 4.5" W.C. (1.12 KPa)    |
| U50 Max BTU/hr Input   | 38,000 BTU/hr (11.1 kW) |
| U50 Min BTU/hr Input   | 25,000 BTU/hr (7.33 kW) |
| U70 Max BTU/hr Input   | 52,500 BTU/hr (15.3 kW) |
| U70 Min BTU/hr Input   | 39,000 BTU/hr (11.4 kW) |

| Propane                |                         |
|------------------------|-------------------------|
| Main Orifice           | #49 (U50) / #44 (U70)   |
| Manifold Pressure      | 10.0" W.C. (2.49 KPa)   |
| Min. Manifold Pressure | 6.4" W.C. (1.59 KPa)    |
| Max Supply Pressure    | 11.0" W.C. (2.74 KPa)   |
| Min. Supply Pressure   | 10.4" W.C. (2.59 KPa)   |
| U50 Max BTU/hr Input   | 38,000 BTU/hr (11.1 kW) |
| U50 Min BTU/hr Input   | 32,000 BTU/hr (9.38 kW) |
| U70 Max BTU/hr Input   | 52,500 BTU/hr (15.3 kW) |
| U70 Min BTU/hr Input   | 43,000 BTU/hr (12.6 kW) |

### Valve Access

The valve may need to be accessed for service or maintenance. Access valve as follows:

1. Remove outer glass (see page 22).
2. Remove right louver (see page 23).
3. Remove the thumb screws (X2) to release the support bracket and gain valve access.
4. Replace support bracket securely when finished.

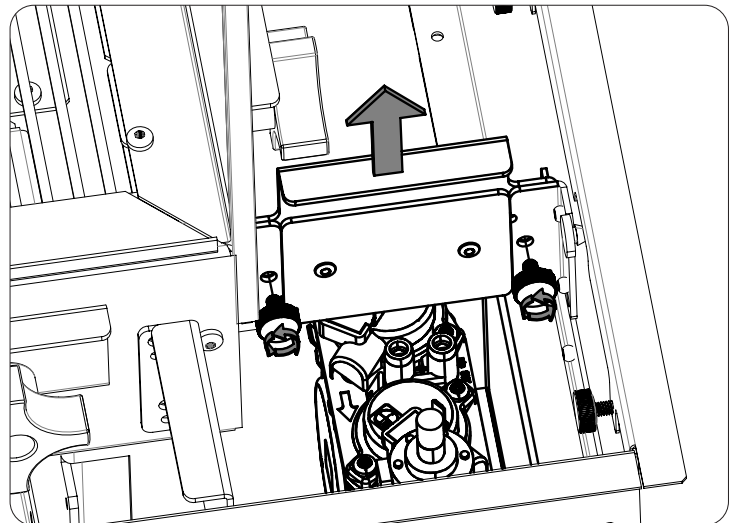

## Maintenance and Service

Run through the procedures in this section to ensure the fireplace system is clean and working properly at least once a year.

Inspect the following:

- Check the burner to see if all the ports are clear and clean.
- Check the pilot to make sure it is not blocked by anything. (The pilot flame should be blue with little or no yellow tips.)
- Visually check pressure relief gasket for damage or deterioration (replace if necessary).
- Check fan for debris such as hair, dirt or pet hair (anything that could impede fan performance).
- Clean inner and outer glass (see page 20 for removal instructions). Use a soft, lint free cloth with a mild glass cleaner to ensure no residue is left behind.

**Caution:** Label all wires prior to disconnection when servicing controls. Wiring errors can cause improper and dangerous operation. Verify operation after servicing.

### WARNING

Failure to reposition parts in accordance with this manual, or failure to use only parts specifically approved with this appliance may result in property damage or personal injury.

## Fan Removal and Maintenance

Remove fan assembly/assemblies as follows:

1. Turn power off at breaker.
2. Remove outer glass (see page 22).
3. Remove louvers (see page 23).
4. Disconnect BLACK and WHITE power leads, pull wires out from under the bent metal fingers on the fan housing
5. If removing the center fan disconnect the PURPLE sail switch wires; take note of which terminals are used.
6. Fan assembly is mounted on a keyslot bracket; lift up and out.
7. Clean any debris from fan blades or axle. Ensure proper keyslot engagement upon reinstallation.

WIRE HARNESS  
RETAINING FINGERS

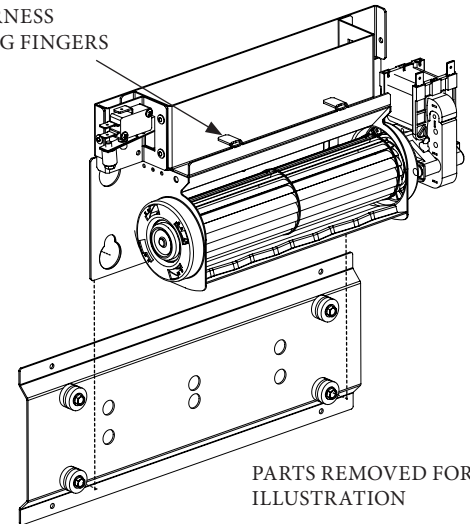

Bench Test (120VAC): If fan operates very slow, not at all, or has abnormally high resistance replace with P/N 50-3901.

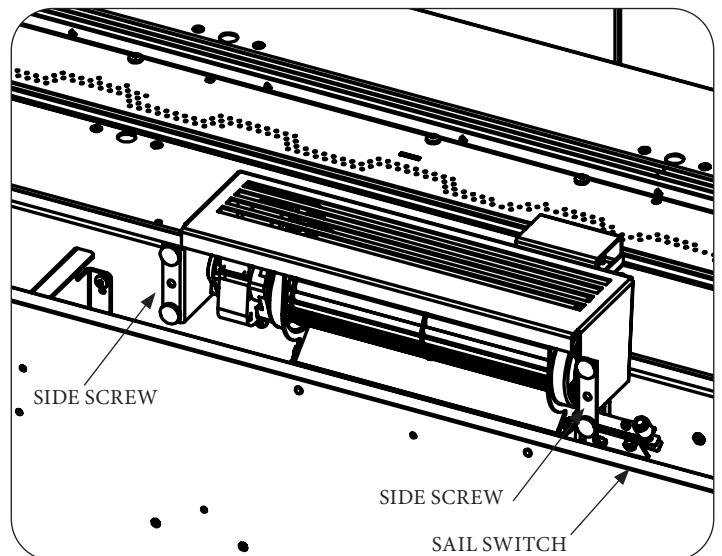

8. To remove the lower chase fan the center fan must first be removed (steps 1-6). The next fan on the right may also need to be unhooked and shifted over.

9. Remove both hand knobs and the glass retainer bracket directly above the chase fan (see page 22).

10. Use a ratchet with a Torx T20 bit to remove the 2 lower side screws and 1 top screw from the chase fan.

11. Disconnect the BLACK and WHITE power leads from the fan as well as the 2 PURPLE wires from the sail switch. Take note of the terminals used.

12. Pull the chase fan forward, rotate it vertically and then lift it up out of the fireplace.

13. Bench Test (120VAC): If fan operates very slow, not at all, or has abnormally high resistance replace with P/N 50-3929.

### Sail Switch Removal and Maintenance

The sail switch is integral to the safety circuit system; it detects sufficient air flow is produced from the cooling fan (see page 19 for detailed information). There is a sail switch located on the center fan as well as the chase fan assembly. Inspect the sail switch(es) as follows:

1. Remove outer glass (see page 2).
2. Remove front louver (see page 23).
3. Remove center fan assembly (see page 13).
4. Check sail paddle for full motion range by activating with your finger; it should return to its fallen position when released.

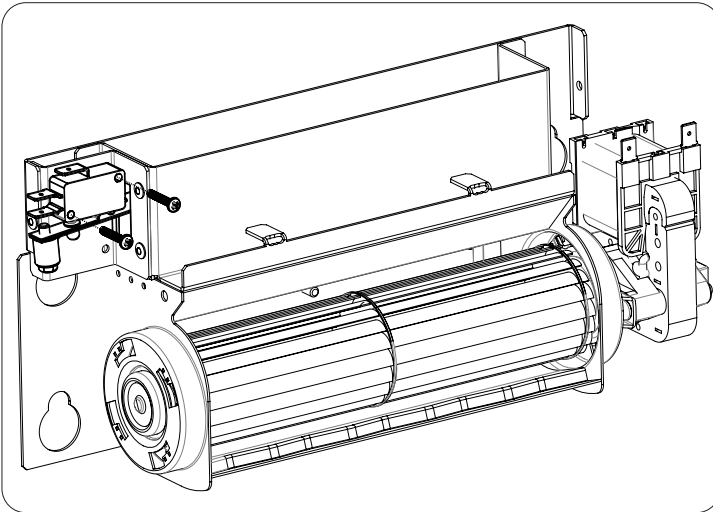

If not, check for binding sail arm or counterweight; adjust as needed. Activate the switch several times to work the internal grease if they fireplace isnt used often. The paddle may need further adjustment if it does not return to the lowest position upon release. Press slightly on paddle while supporting at counterweight to adjust sensor. Be gentle, sensor is delicate and could damage easily.

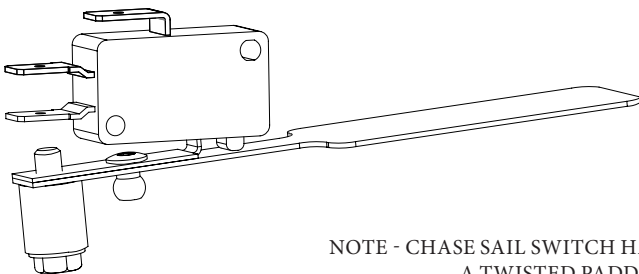

NOTE - CHASE SAIL SWITCH HAS  
A TWISTED PADDLE

5. Bench test sail switch by checking continuity across AB terminals. Switch should read normally open, and closed when switch is depressed.

6. If the center fan sail switch tests normally remove the chase fan assembly (see page 13). Repeat the same inspection and bench test procedure.

Sail switch assembly replacement P/N 50-3898

Chase switch assembly replacement P/N 50-3928



## Component Tray Map

The component tray is fixed underneath the firebox. All components are affixed to the tray using velcro for servicing ease. Remove cooling fan assembly to gain access.

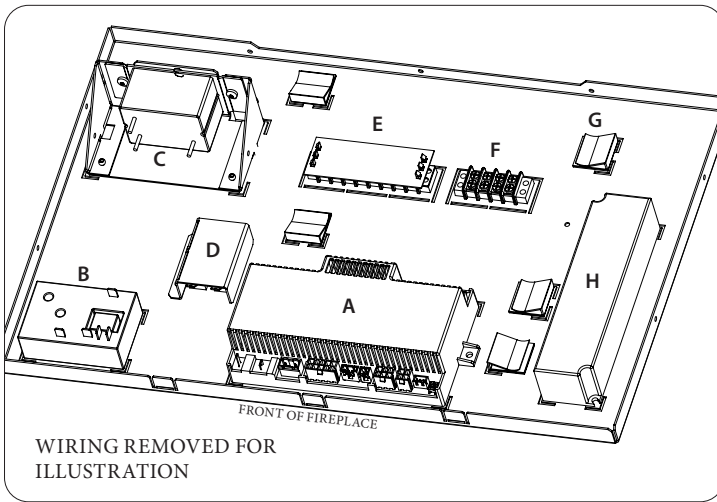

**WARNING**  
**ELECTRIC SHOCK RISK!**

**DISCONNECT POWER FROM BREAKER BEFORE ACCESSING COMPONENT TRAY**

- A** - Proflame 2 IFC Control Board #50-3887
- B** - Timing Relay #50-3899
- C** - Fan Rheostat (Fixed) #50-3900
- D** - Fuse Cover
  - Left 4A Fuse - Fan Circuit #50-2076
  - Right 4A Fuse - Top Light #50-2076
- E** - Power Terminal Bar (Covered) TILT UP FOR ACCESS
- F** - Ground Terminal Bar TILT UP FOR ACCESS
- G** - Wiring Clip
- H** - LED Driver (If equipped) - #50-3890

## Fuse Replacement - Fan and Top Light

Determine what caused fuse to blow before replacement. Replace fuse as follows:

1. Disconnect power at circuit breaker.
2. Remove outer glass (see page 22).
3. Remove louvers (see page 23).
4. Remove fan assembly (see page 13).

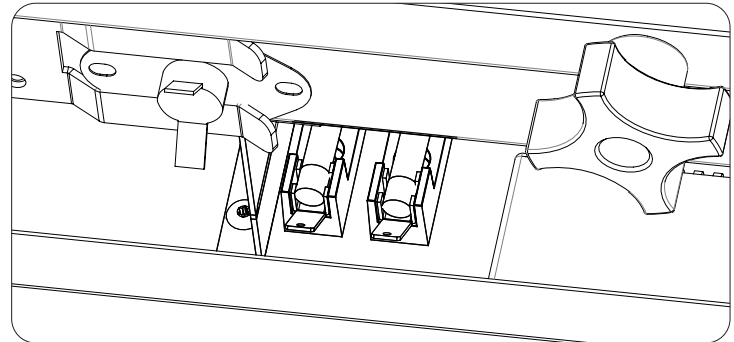
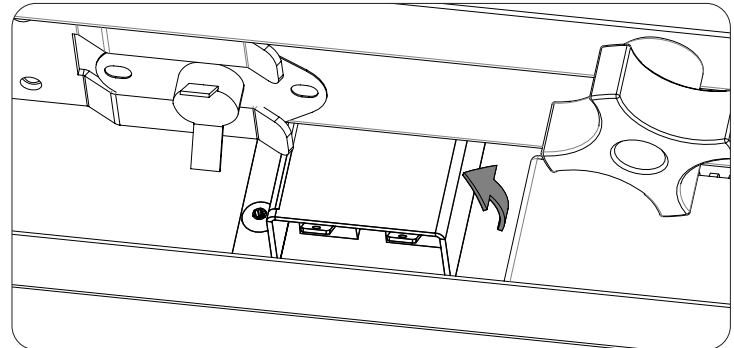

5. Lift cover up for fuse access

- Left - Cooling Fan Circuit
- Right - Top Light Circuit

## Snap Disc

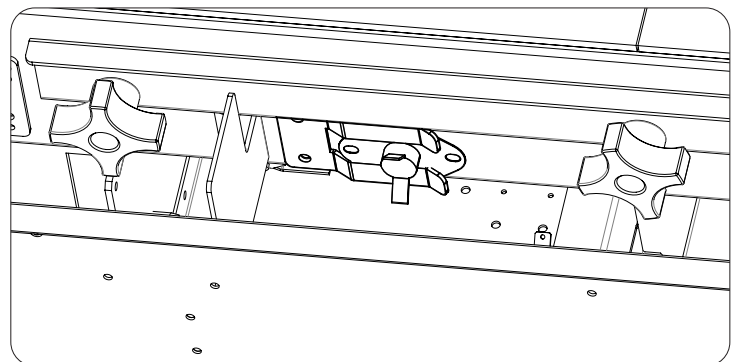

The snap disc is part of the safety circuit system; see page 19 for more details. The sensor is located on the lower firebox face. Disconnect unit power at the circuit breaker before handling.

### Pilot Light

The pilot flame should cover 1/4" to 1/2" (7 to 13mm) of the flame sensor (see photo). The pilot flow adjustment is set to maximum from the factory and should not need adjustment. However, should the need arise, adjust pilot flame as follows:

1. Remove outer right glass (see page 22).
2. Remove right louver (see page 23).
3. Locate the pilot adjustment screw on the valve (see photo).
4. Turn the adjustment screw to alter the pilot gas flow as needed.

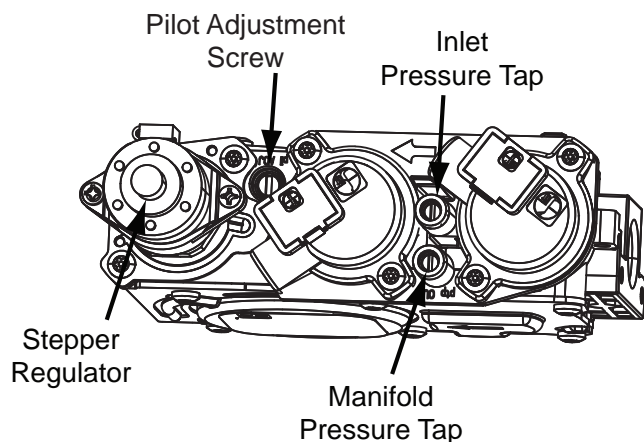
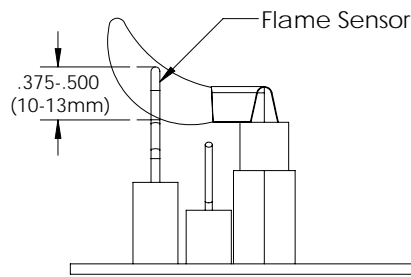

### Air Shutter (Venturi)

The air shutter plays a very important role in flame appearance and combustion quality. The shutter adjusts how much air gets mixed with the gas before it ignites. We recommend starting the fireplace and allowing it to heat up for 15 minutes before making final adjustments. Adjust the shutter as follows:

1. Remove outer right glass (see page 22).
2. Remove right louver (see page 23).
3. Locate air shutter linkage knob (see photo) and adjust as needed.

Lean (more primary air): Pull knob outward to make flame appear more blue and low.

Rich (less primary air): Push knob inward to make flame appear more yellow and tall. Flame will continue to richen up during operation creating a potential for gradual soot build-up.

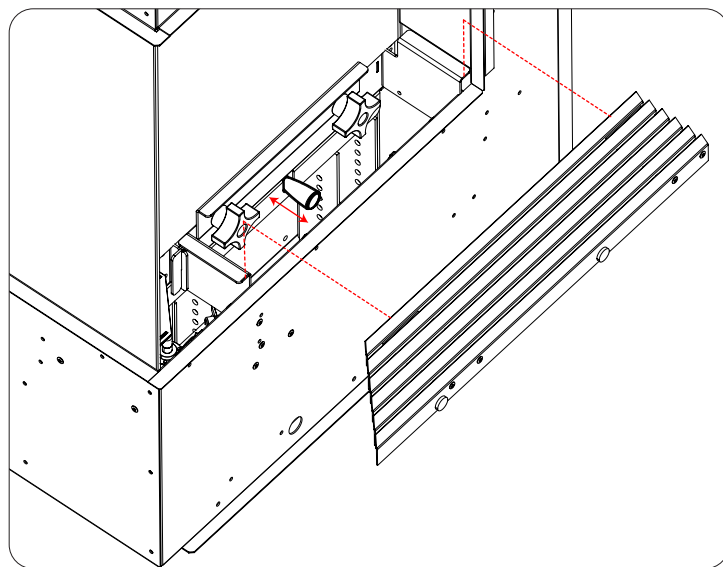

#### Notes:

- If you cannot attain a healthy flame by making air shutter adjustments, you may have the incorrect restrictor setting or a venting problem.
- Propane units have very little to no adjustment.
- More details can be found in the venting section of this manual.
- Caution: Wear heat resistant gloves when making adjustments to the air shutter. Perform final adjustments after 15 minutes.

## Remote Syncing

The remote should be synced to your fireplace by your installer during installation.

Your remote may gradually lose its RF connection strength over time. Resync the remote if this happens or if the batteries have been changed. Resync remote as follows:

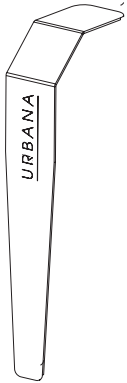

1. Locate the switch tool supplied with your fireplace (see photo).
2. Locate the hidden switch panel mounted on inner fireplace cabinet.
3. Slip the tool in between the front glass and cabinet and press the middle switch. You will hear 3 beeps from the IFC.

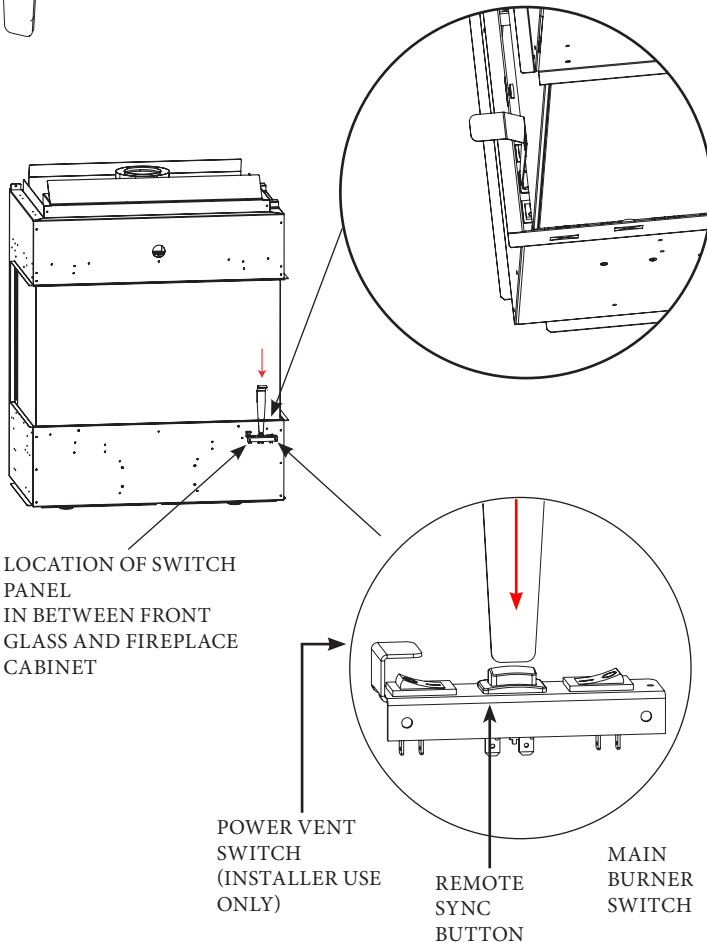

4. On hearing the 3 beeps, press the ON/OFF key on your remote; you will hear 3 more beeps to acknowledge successful remote syncing.

5. Press the ON/OFF key again to turn off the remote. The remote is now ready to use.

## Power Vent (PV) Switch

For convenience, the fireplace comes pre-wired for power vent applications. If needed, to switch into power vent (PV) mode locate the PV switch next to the Remote Sync Button. The far left rocker switch with the cover above it controls the mode setting of the fireplace's IFC. From the factory the - symbol is down, press the rocker switch so that the O symbol is down. To clarify:

- symbol down = Direct Vent (DV) mode
- O symbol down = Power Vent (PV) mode

If for some reason the IFC needs to be switched back to DV mode simply press the switch again **with main power disconnected**.

**IMPORTANT** - Main power **must not** be connected to the fireplace prior to switching between DV and PV modes. If power is connected the IFC will remain in the previous mode until power is removed. Turning the fireplace on and off via the remote will not correct this.

**Quick Tip** - A typical symptom of the fireplace being inadvertently switched to PV mode is a responsive remote with full control of the Light and AUX circuits but no pilot ignition sequence.

### Top Light Replacement

Occasionally the top light bulb(s) good will need to be replaced.

Replace the top light as follows:

1. Disconnect electrical power to the unit.
2. Remove outer glass (see page 22).
3. Remove inner glass (see page 24).
4. Use a 5/16 socket to remove the 4 fasteners securing top light assembly; let assembly drop slowly.
5. Grab connectors firmly at the base and disconnect from bulb assembly; remove assembly from unit.
6. Use a T20 screwdriver to remove light

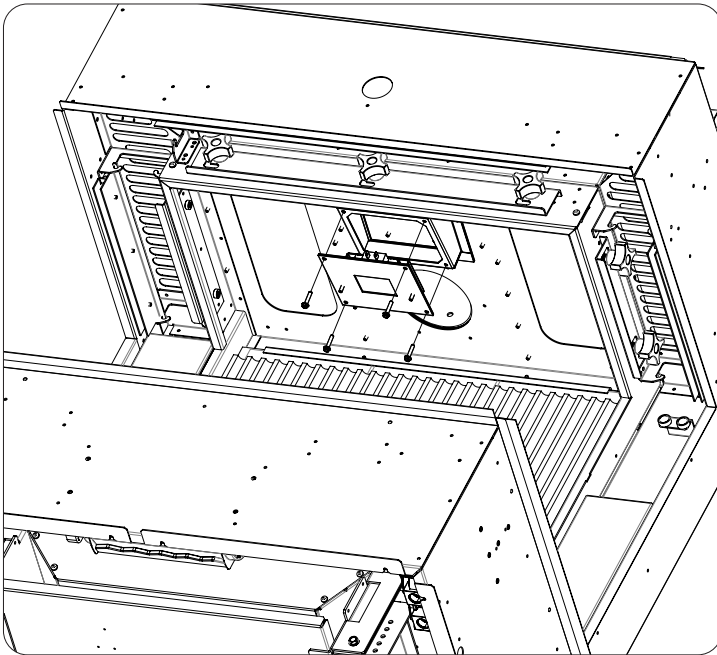

cover. Replace light gasket if damaged.

7. Replace light assembly (50-1516) or replace bulb with 120V, Halogen G9, 25W and assemble back into unit.
8. Reconnect electrical power.

### Burner Removal

The burner may need to be replaced if defected or damaged. Replace burner as follows:

1. Remove outer glass (see page 22).
2. Remove louvers (see page 23).
3. Remove inner front glass (see page 24).
4. Remove all media from burner platform.

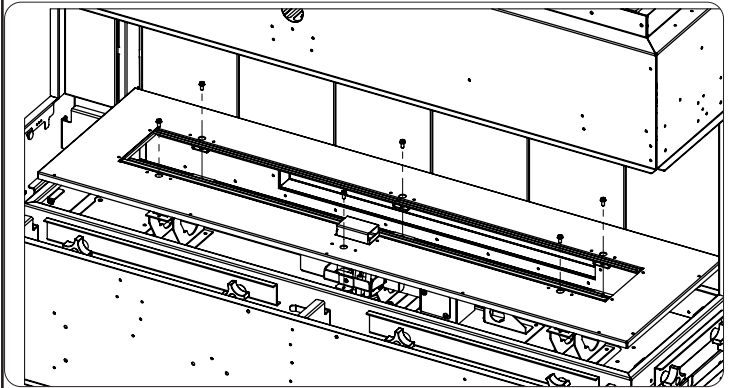

5. Use a 1/4 socket (magnetized) to remove the fasteners (U50 = 6, U70=10) securing burner platform.

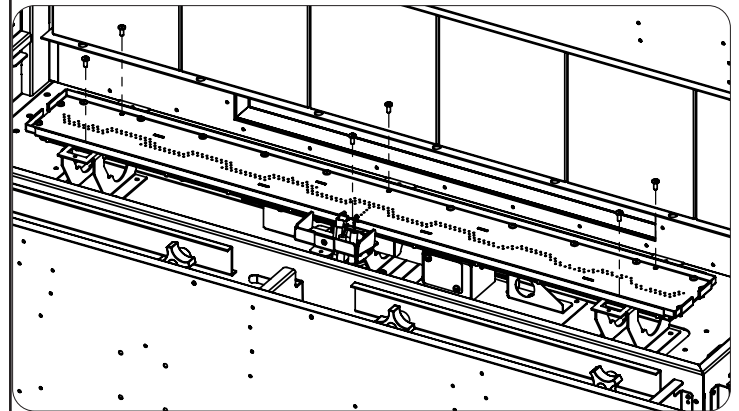

6. Use a T20 screwdriver to remove the fasteners (U50 = 6, U70 = 10) securing the burner.

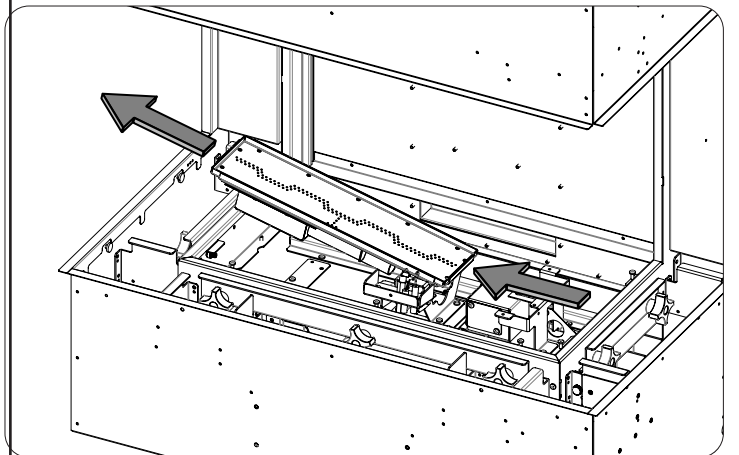

DO NOT remove remaining burner screws.

## Safety Circuit System

Your fireplace has a safety circuit system designed to protect you and your home from damage due to unmanaged heat. This section outlines the safety components, how they work, and how to test them in the event of malfunction.

The safety system is activated after 15-20 minutes.

The safety system is integrated with the IFC ON/OFF circuit. The burner will not operate unless the circuit is satisfied (also a closed burner switch).

Start-up mode: Safety system is not activated yet; circuit is in bypass mode through the timing relay (normally closed).

Operating mode: Snap disc (normally open) will close when it reaches operating temperature (120F); this will send 120VAC to the cooling fan system (see below) and timing relay.

Cooling fan system rheostat resists the input to 98-103VAC; this is a set input and should be confirmed during installation via the open center terminals in the fan harness. The rheostat has a limited range of adjustment, DO NOT attempt to adjust it lower when resistance on the knob is felt.

The timing relay switches safety system out of bypass mode and the circuit is now dependant on the sail switch circuit. There is a 5 second delay to allow cooling fans to reach operating speed.

The sail switch (normally open) senses the monitored fans are operating with optimal air flow. The flow will active the sail paddle and close the circuit when satisfied.

Power will continue to run through the cooling fan system with the fireplace turned off. Only when the snap disc falls below its set temperature will the fans turn off.

## Safety Circuit Components

**Snap Disc:** Activates safety system when fireplace is sufficiently hot.

Testing:  
 AB (cool): NO continuity  
 AB (hot 120F+): YES continuity

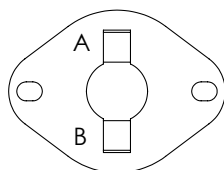

**Timing Relay:** Switches system from bypass mode to operating mode when powered via snap disc. There is a 5 second delay to give fans time to build speed.

Testing:  
 CE (no power at AB): YES continuity  
 CE (120VAC at AB): NO continuity  
 Terminal D is irrelevant

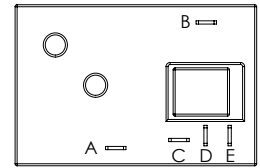

**Cooling Fan Rheostat:** Resists input power to cooling fans for optimal speed and noise reduction.

Testing:  
 AB: 70-75VAC on lowest setting

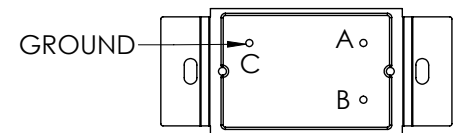

**Cooling Fans:** Draw air from the lower framing gap to create an airwash through the inner and outer glass barrier; the heat is released at upper framing gap.

\*U50/U70 models also use a chase fan to cool the rear framing cavity.

Testing:  
 AB: 14-15 ohms is good  
 AB: 105-110V when running is optimal



**Sail Switches:** Two sail switches monitor select cooling fans to sense proper air flow in being achieved.

Testing:  
 AB: NO continuity (no air flow)  
 AB: YES continuity (with air flow)  
 Terminal C is irrelevant

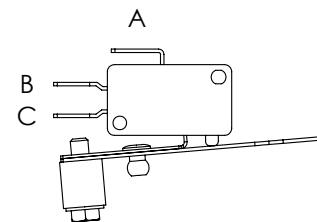

**Breathable Framing:** Provides the air wash needed for the cooling fans to do their job. Framing must be constructed in accordance with this manual; failure to do so will result in property damage or personal injury.

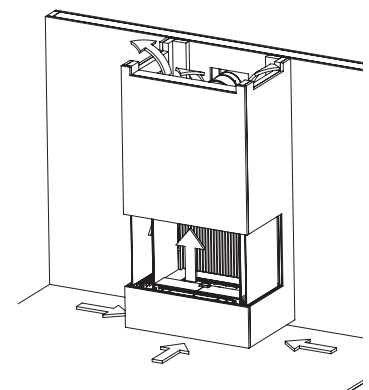

### Outer Glass Removal

Initial paint curing of the appliance can leave a slight film on the glass. The glass will need cleaning after the fireplace has cooled off from the first burn and about two weeks after first burn. Use a mild glass cleaner and a soft cloth. Depending on the amount of use, the glass should require cleaning no more than two or three times a season.

**CAUTION:** Abrasive cleaners will damage the glass and painted surfaces. **Do not clean the glass when it is hot.**

The 5mm thick outer glass is tempered. Handle glass with care; breaking will result in a dangerous mess. Use a shop vacuum to clean if a break occurs. All glass should be handled with quality suction cups such as 50-3837. Two suction cups must be used for larger glass segments. Remove outer glass as follows:

1. Familiarize yourself with the glass hooking method in the following steps before proceeding.

**NOTE:**

**Left and right side glass must be removed before front glass.**

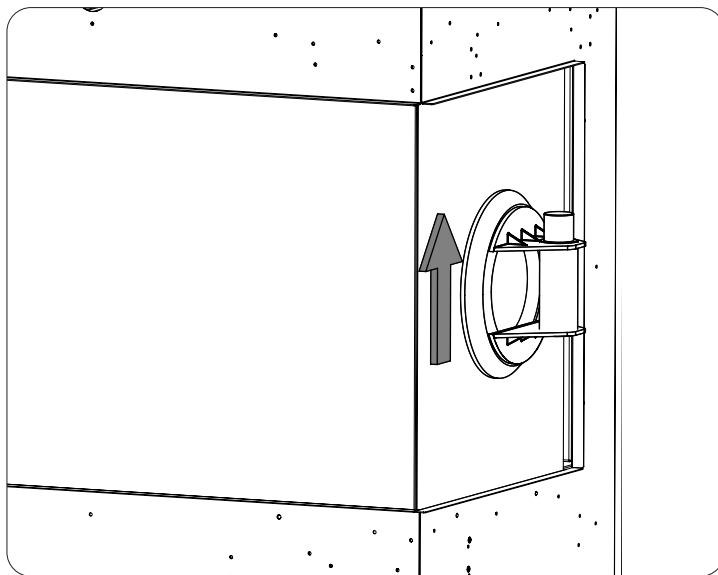

2. Attach suction cup to center of either side glass. Pump plunger to build suction; a disappearing red line will indicate if airtight seal is made.
3. Lift glass up, tip top inward and pull bottom outward until hook disengaged. Lower glass and continue to remove leading with bottom. Be sure to clear lower cabinet.

DO NOT force the glass if binding. Uneven glass pressure can cause breakage. Use a helper for larger glass segments to distribute weight.

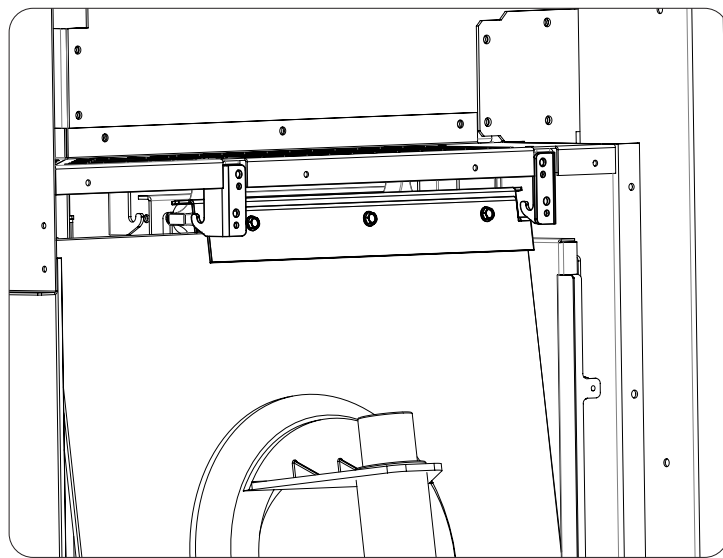

PARTS REMOVED FOR ILLUSTRATION PURPOSE

## Louver Removal

Louver assemblies will need to be removed to access components and firebox. There are two side louver assemblies and one front; the sides need to be removed first. Remove louvers as follows:

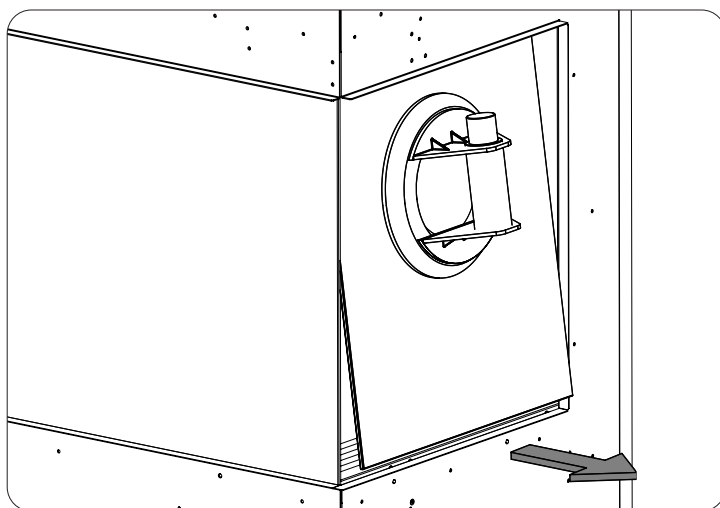

**4.** Remove front glass using same method after both side glass sections have been removed.

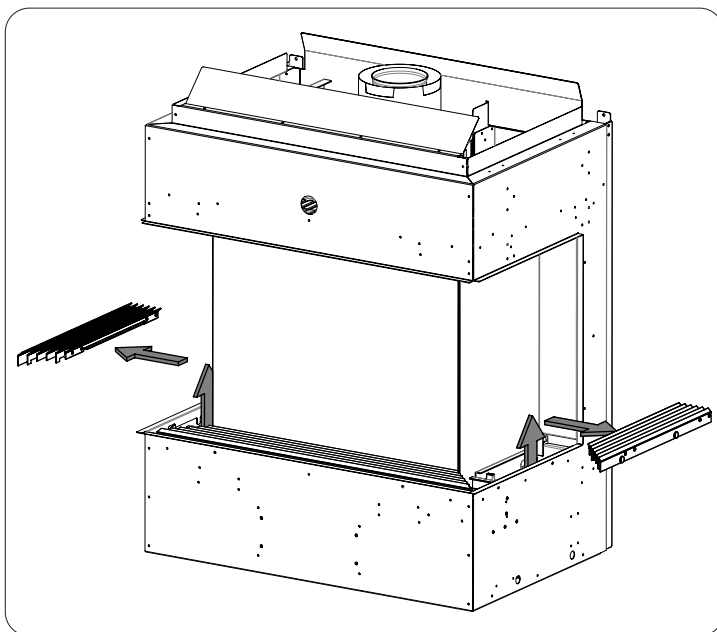
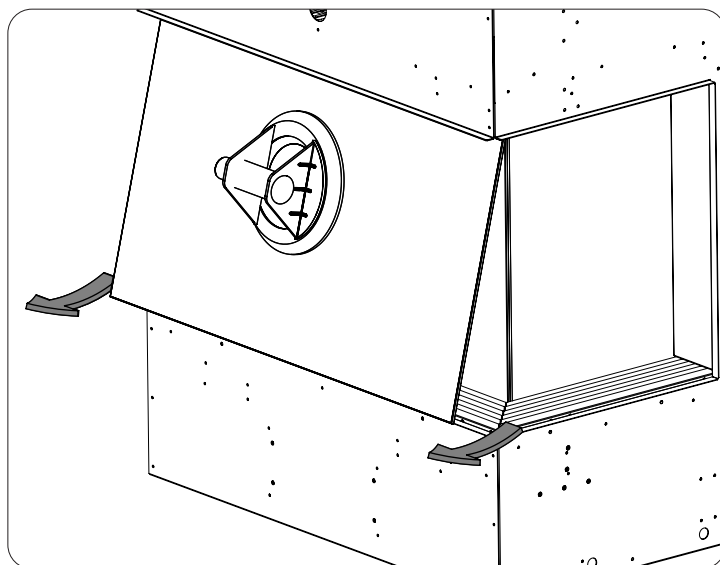

**1.** Remove outer glass as needed (see page 20).

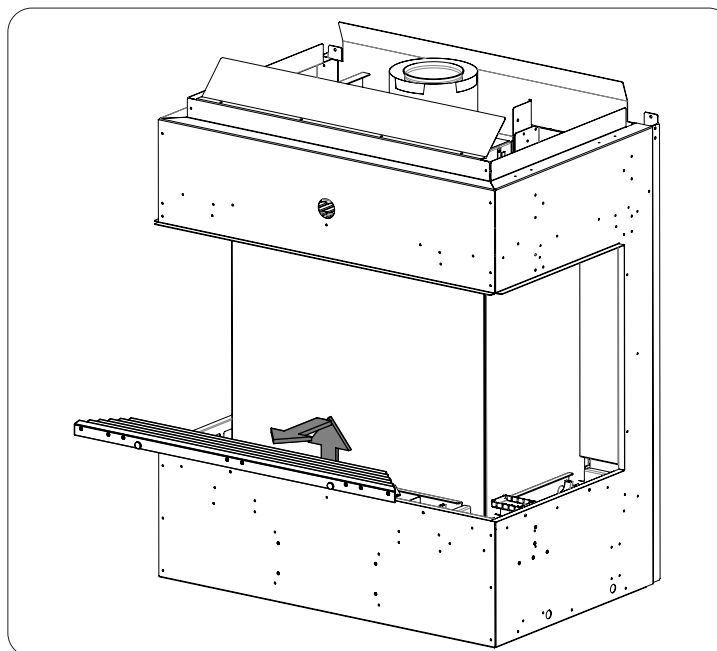

**2.** The louvers are not secured into place, simply lift up and out. Remove side louvers first (as needed).

Reverse to this procedure by lining up tabs and slots when reinstalling.

### Inner Glass Removal

The 5mm thick inner glass is ceramic. Handle glass with care; breaking will result in a dangerous mess. Use a shop vacuum to clean if a break occurs. All glass should be handled with quality suction cups such as 50-3837. Two suction cups must be used for larger glass segments.

**ONLY** the front inner glass needs to be removed for firebox access. Remove side glass only if necessary. Side glass uses adjustable back stops to maintain seal on front glass. If side glass is removed be sure back stops are adjusted correctly. Remove the front inner glass as follows:

**1. Remove outer glass (see page 22).**

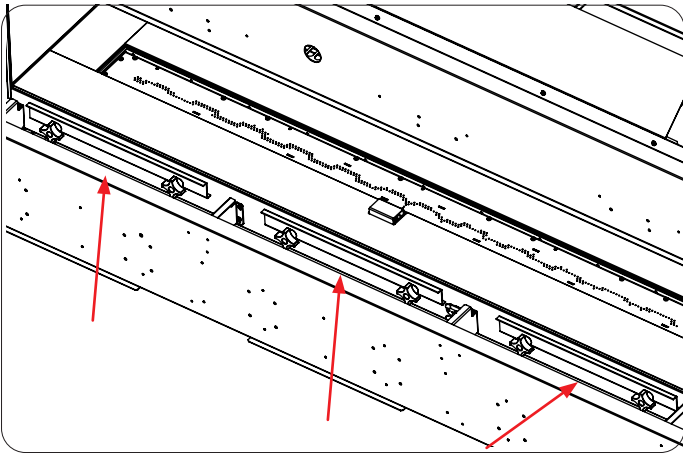

**2. Remove louvers (see page 23).**

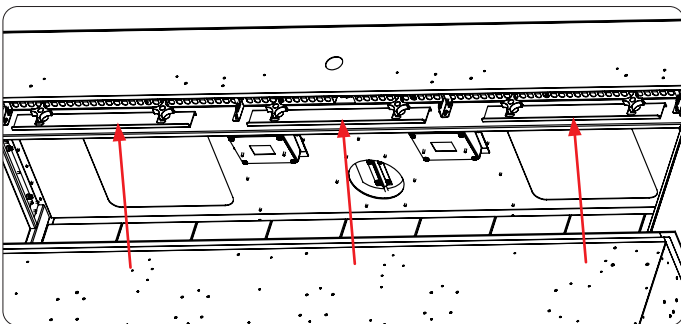

**3. Loosen the 3 sets of knobs at the bottom of the glass.**

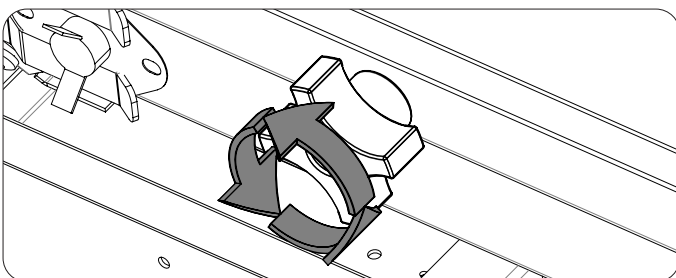

**4. Loosen the 3 sets of knobs at the top of the glass. Each retainer has a slotted "dog-leg" profile, shift each retainer right-up-left to clear the glass.**

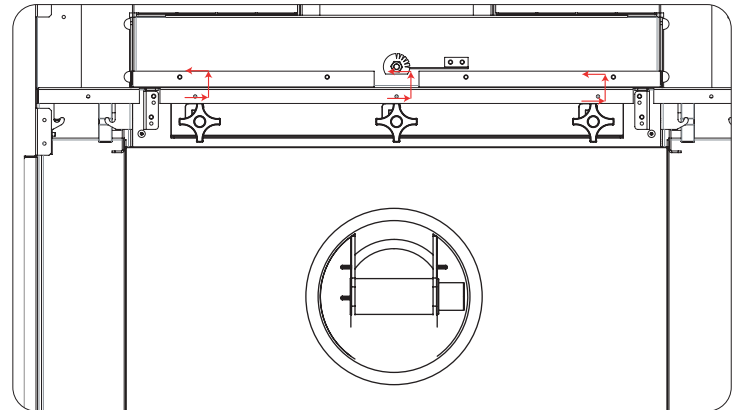

**MAKE SURE** all three retainer brackets are in final position during assembly for even sealing pressure.

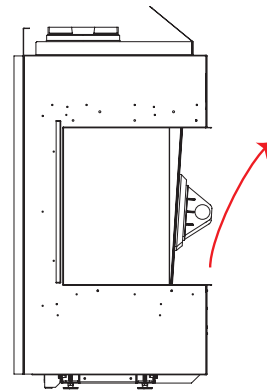

**5. Attach suction cup to the glass ensuring**

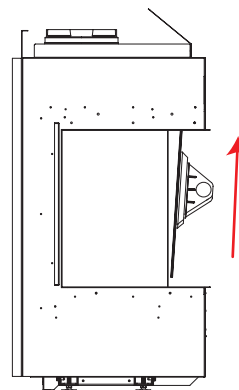

strong engagement.

**6. Allow glass to fall forward some.**

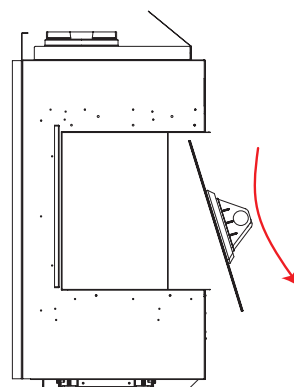

**7. Lift glass up until bottom is higher than fireplace edge.**

**8. Swing glass bottom outward, removing it from the unit.**



## Media Placement (LED Unit)

The unit comes with a measured amount of clear diamond glass to cover the burner and the burner platform. Install media as follows:

1. Remove outer glass (see page 22).
2. Remove louvers (see page 23).
3. Remove front inner glass (see page 24).
4. Evenly spread out clear diamond glass onto burner and burner platform.
5. Pat down media to create 1 even layer.  
**DO NOT block air flow to burner.**

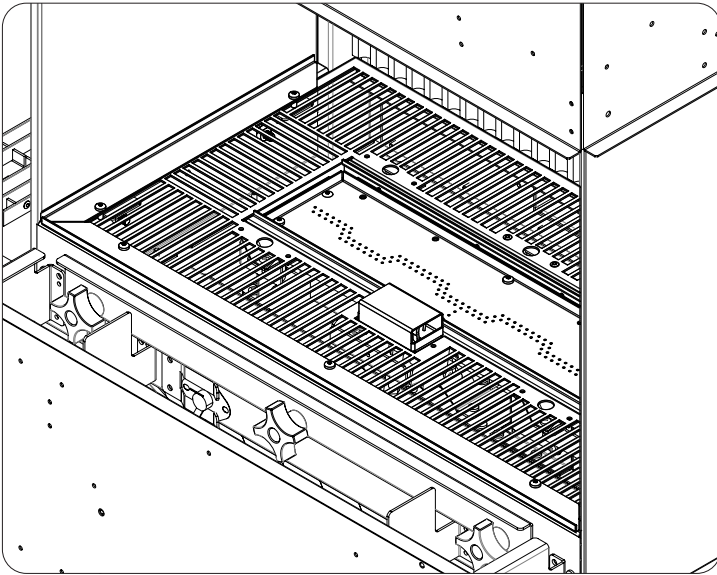

**CAUTION:**  
**DO NOT BLOCK AIR SLOTS AROUND BURNER PERIMETER;**  
**POOR FLAME WILL RESULT.**

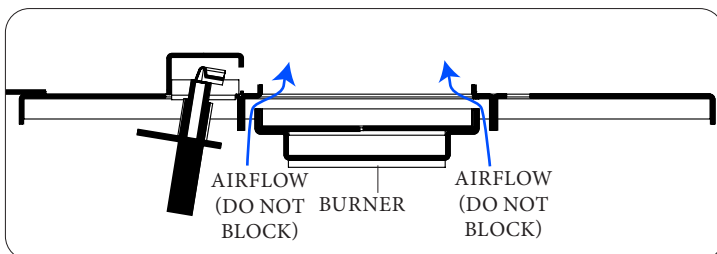

## Media Placement (Standard Unit)

The unit comes with a painted steel bezel set and a measured amount of vermiculite to cover the burner. Install media as follows:

1. Remove outer glass (see page 22).
2. Remove louvers (see page 23).
3. Remove front inner glass (see page 24).
4. Evenly spread out vermiculite onto burner.
5. Insert the steel bezel onto the burner platform; make sure it's sitting flat.

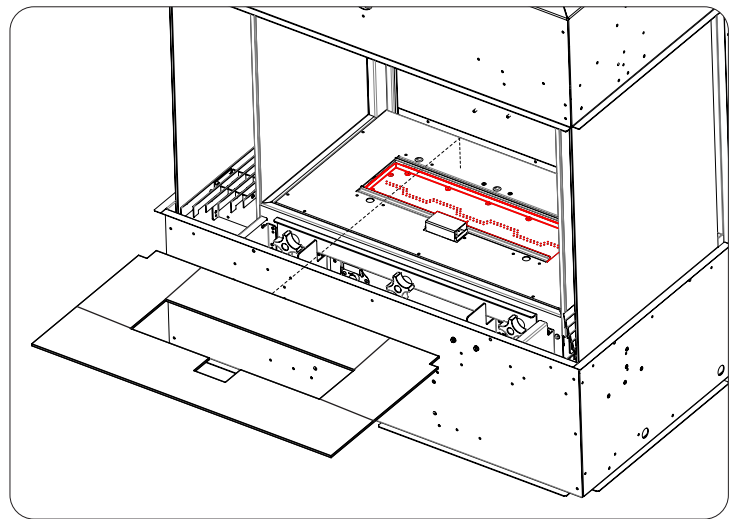

6. Add any additional options such as rocks or logs and reassemble unit.

### Final Firebox Sealing

**Sealing the firebox is essential** for safety and proper flame characteristics. **The firebox requires liquid silicone at the top and bottom inner glass corners after initial set up is complete.** Make sure all log and media placement is satisfied before proceeding. Seal the firebox as follows:

1. Confirm fireplace log (if used) and media placement (see page 23).
2. Reinstall front inner glass, ensure glass is sealed at the corner edging. If not, massage silicone strip gasket - inner side glass should not need adjustment. Test fire for 15 minutes for an established flame and make adjustments if necessary.

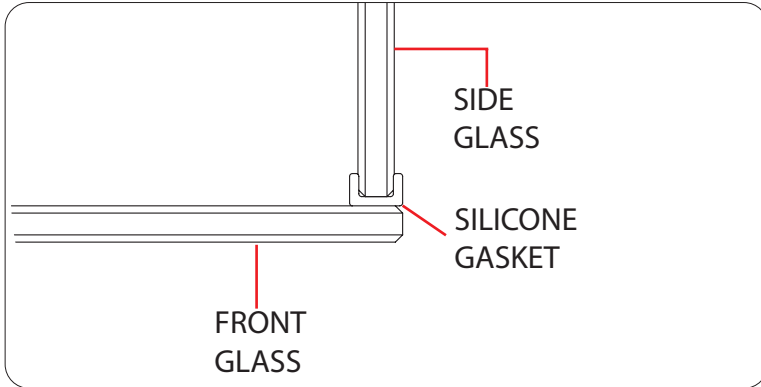

3. When unit has cooled, blob some clear high-temp silicone (not included) around the 4 corners of the front glass. Make sure you fill up any space between the glass and firebox.

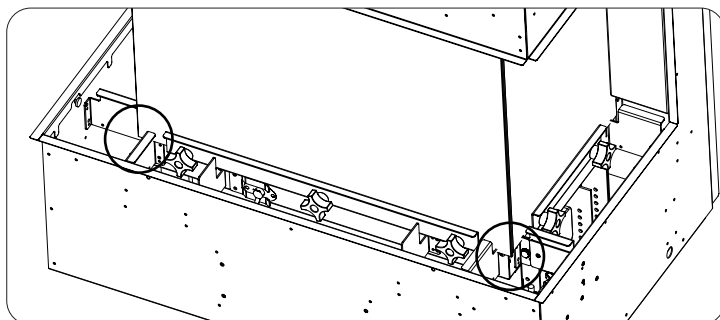
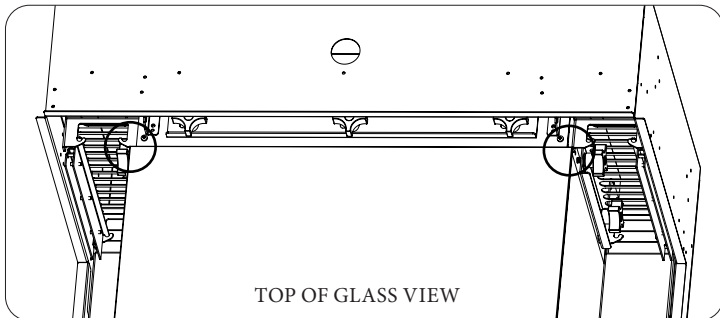

## Chase Framing

### WARNING

**IT IS ESSENTIAL THAT THE CHASE IS VENTED IN A MANNER THAT RELIEVES THE ADDITIONAL HEAT ENTERING THE CHASE. ENSURE ONE OF THE AVAILABLE FRAMING OPTIONS HAVE BEEN CONSTRUCTED IN ACCORDANCE WITH THIS MANUAL. FAILURE TO DO SO CAN CREATE AN OVERHEATING SITUATION THAT COULD LEAD TO BUILDING FIRE.**

Ensure your chase has been constructed in a manner that vents the chase into the same room. It is not permitted to vent the chase into an adjoining room. The fireplace cooling system bleeds heat into the chase as opposed to climbing up the front face. This dramatically lowers the front wall temperatures allowing the placement of delicate objects above the fireplace. Review the following guidelines to ensure your install is in accordance with the framing specifications.

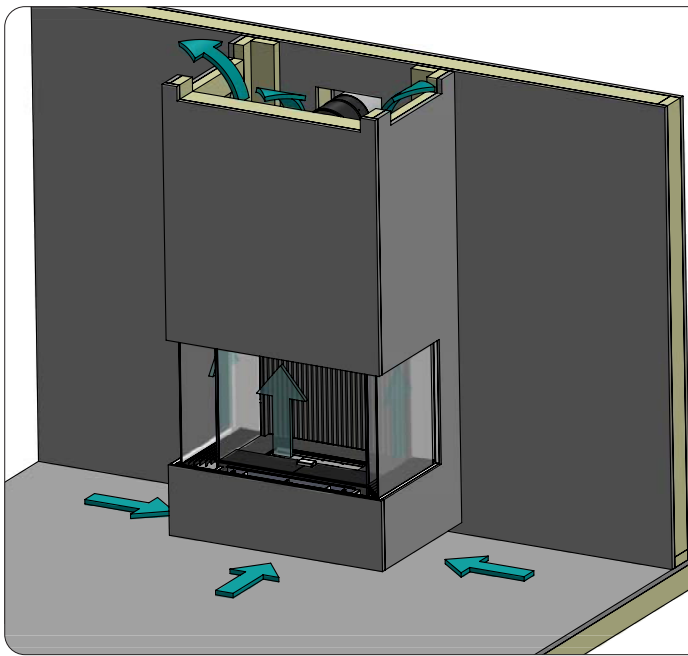

### Framing Air Gaps

Your fireplace uses an air wash to cool the outer glass and maintain safe temperatures inside the chase. This air wash runs through the two layers of glass and is powered by a cooling fan that requires an inlet and outlet for air to flow. These air gaps must be created in framing and the minimum areas must be adhered to.

The air gap needed for the air inlet and outlet are based on minimum open area requirements:

**U50 Air Inlet (Minimum): 135<sup>2</sup> (871 cm<sup>2</sup>)**  
**U70 Air Inlet (Minimum): 165<sup>2</sup> (1064 cm<sup>2</sup>)**  
**Gap Height Minimum: 1 1/2in (38mm)**

**U50 Air Outlet (Minimum): 170in<sup>2</sup> (1097 cm<sup>2</sup>)**  
**U70 Air Outlet (Minimum): 210in<sup>2</sup> (1355 cm<sup>2</sup>)**  
**Gap Height Minimum: 2in (51mm)**

**Ex. 1" x 170" is not permitted.**

There is no maximum air gap surface area.

## Framing Options

All framing may be wood 2X4 construction or the like, no steel stud or concrete board required.

The following diagrams are common ways to frame your fireplace. Other forms can also be used as long as minimum clearances and air gaps are maintained.

### NOTES:

- Chase may be framed beyond minimum framing for taller ceilings, overhangs etc.
- Chase cannot be open to joists or rafters above.
- The fireplace is not load bearing so the chase must be constructed to fully support finishing materials.

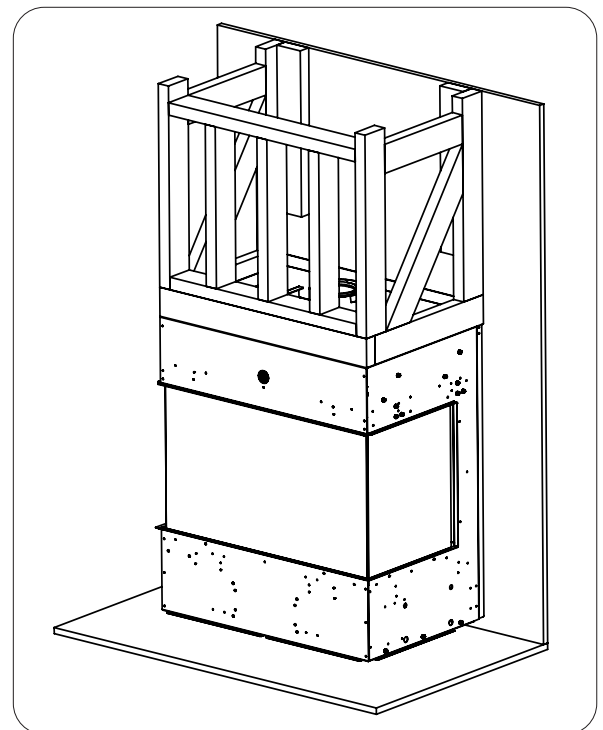

**IMPORTANT NOTE: Framing above the fireplace CANNOT be constructed prior to fireplace installation, the fireplace and it's required shielding WILL NOT FIT!**

### Minimum Framing Clearances

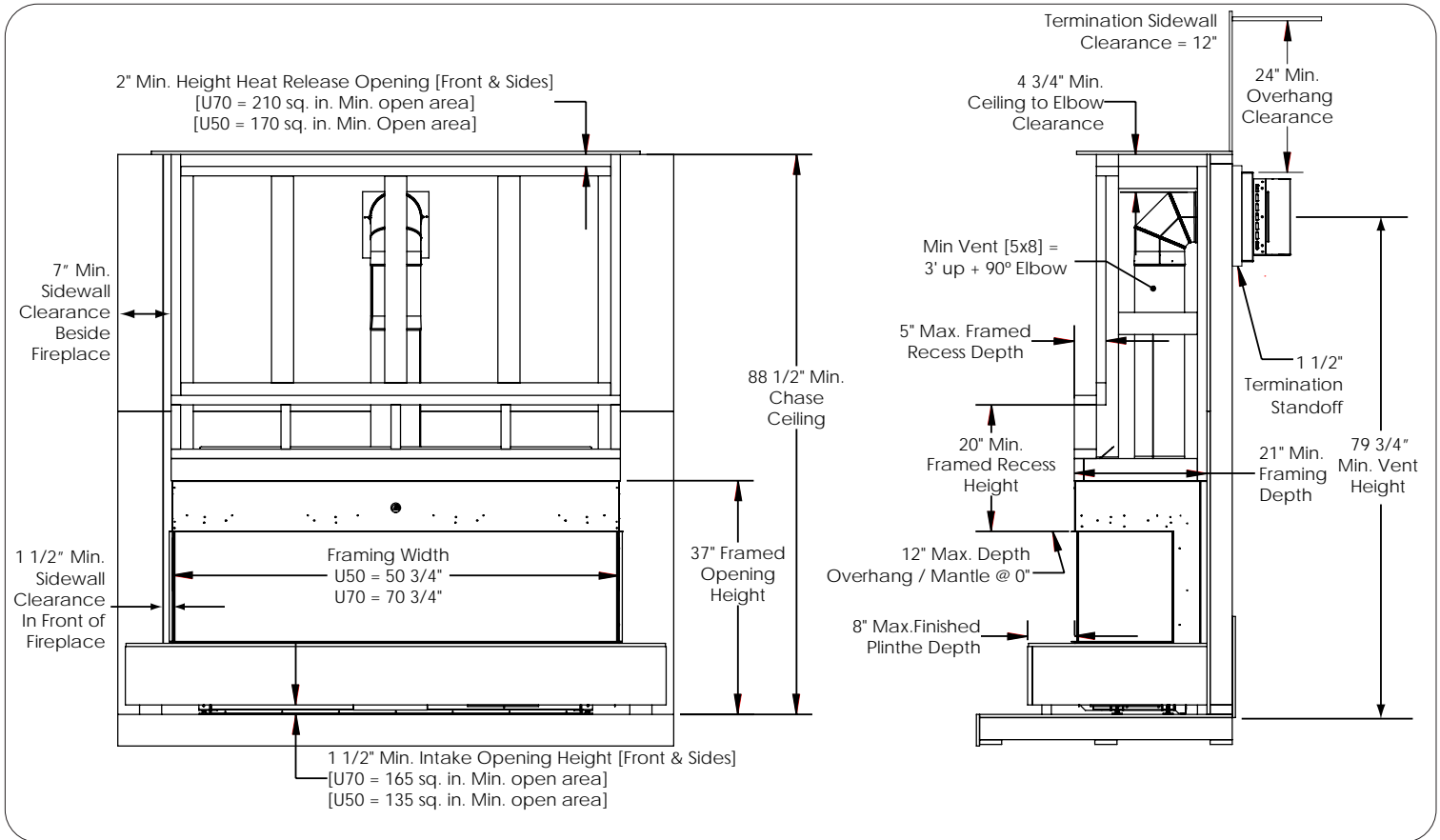

### Minimum Framing Clearances

All framing may be wood 2X4 construction or the like, no steel stud or concrete board required.

Using wood framing is a result of meticulous design and testing practices. We ask that the restrictions be followed in order for the fireplace to be enjoyed safely.

#### NOTES:

- Chase may be framed beyond minimum framing for taller ceilings, overhangs etc.
- Chase cannot be open to joists or rafters above.
- Chase heat release(s) must be at least 60" (152 cm) away from the nearest fire sprinkler head.
- The fireplace is not load bearing so the chase must be constructed to fully support finishing materials.
- Minimum intake dimensions must be taken at the fireplace cabinet, not the end of the hearth/plinth.
- Less restricted air flow will always breathe more efficiently maintaining cooler surface temperatures.

The following diagrams are common ways to frame your fireplace. Other forms can also be used as long as minimum clearances and air gaps are maintained. Use the diagrams and table on the following page as a baseline to design your enclosure. Framing illustrations are for example only and are not necessarily meant to be followed exactly.

| LETTER         | DIMENSION              |
|----------------|------------------------|
| <b>A</b>       | 86 1/2" (2197 mm)      |
| <b>B</b>       | 21" (533 mm)           |
| <b>C (U50)</b> | 50 3/4" (1289 mm)      |
| <b>C (U70)</b> | 70 3/4" (1797 mm)      |
| <b>D</b>       | 9 15/16" (253 mm)      |
| <b>E</b>       | Minimum 1 1/2" (38 mm) |

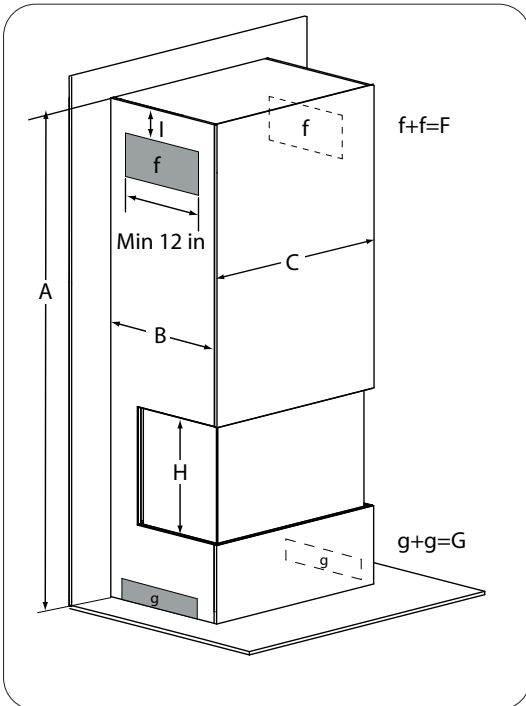
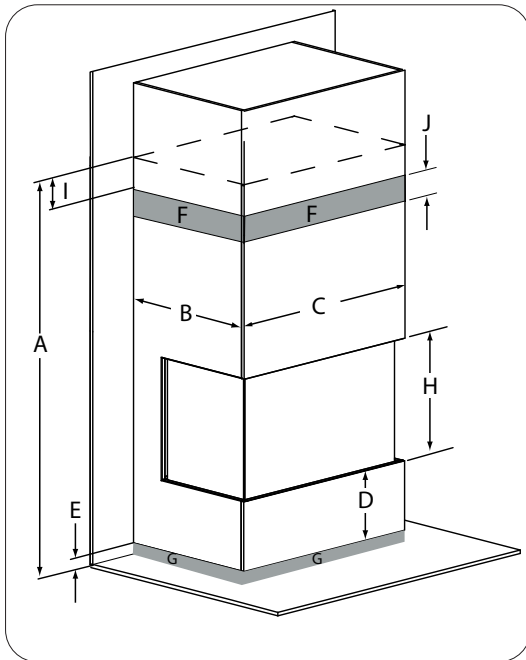
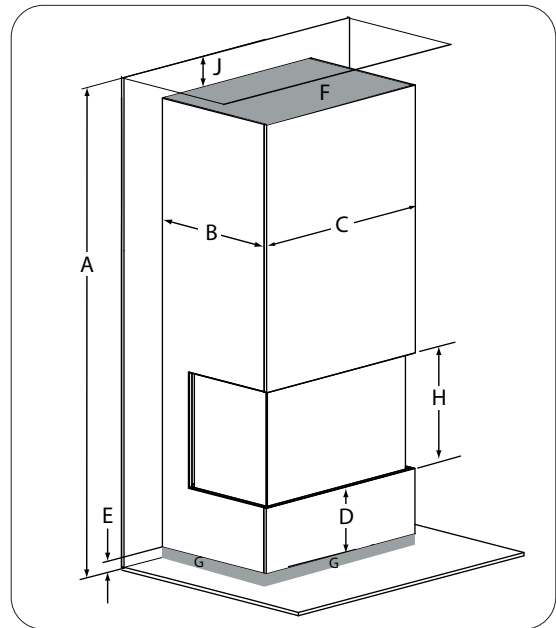

|                |   |
|----------------|---|
| <b>F (U50)</b> | Minimum 170 in <sup>2</sup> (1097 cm <sup>2</sup> ) |
| <b>F (U70)</b> | Minimum 210 in <sup>2</sup> (1355 cm <sup>2</sup> ) |
| <b>G (U50)</b> | Minimum 135 in <sup>2</sup> (871 cm <sup>2</sup> )  |
| <b>G (U70)</b> | Minimum 165 in <sup>2</sup> (1064 cm <sup>2</sup> ) |
| <b>H</b>       | 17 3/8" (441 mm)                                    |
| <b>I</b>       | 0 - 1 1/2" (0-38 mm) Maximum                        |
| <b>J</b>       | Minimum 2" (51 mm)                                  |

A = Height from unit base to enclosure ceiling

B = 2X4 framing depth (doesnt include facing material) - Additional framing can be attached for wider enclosures

C = 2X4 framing width (doesnt include facing material) - Additional framing can be attached for wider enclosures

D = Distance spanning both finishing edges

E = Surface area calculations do not apply to dimensions less than min.

F = Total required surface area for heat release (min. 12" [305mm] wide)

G = Total required surface area for air intake

H = Distance spanning both finishing edges

I = Distance Heat release must be from enclosure ceiling or a false ceiling will be required

J (Open Top) = Height from open enclosure heat release to ceiling

J (Closed Top) = Surface area calculations do not apply to dimensions less than min.

**Minimum intake dimensions must be taken at the fireplace cabinet, not the end of the hearth/plinth.**

\*Framing illustrations are for example only and are not necessarily meant to be followed exactly.

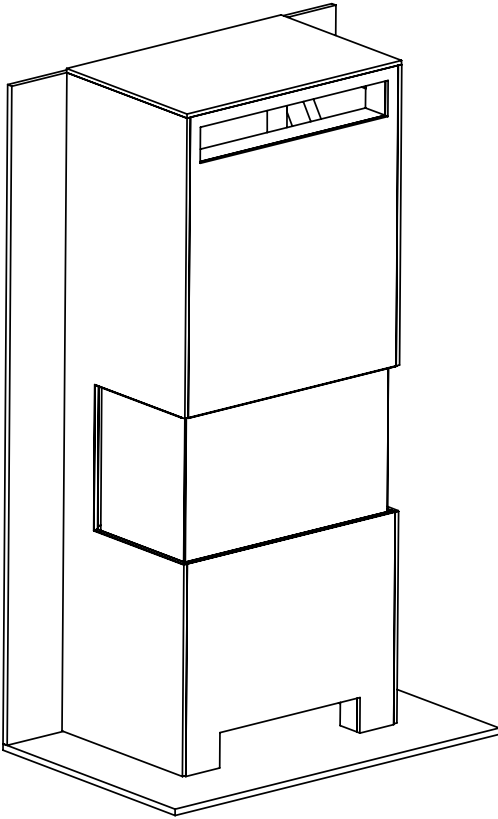

HEAT RELEASE: FRONT  
AIR INTAKE: FRONT  
WITH PEDESTAL

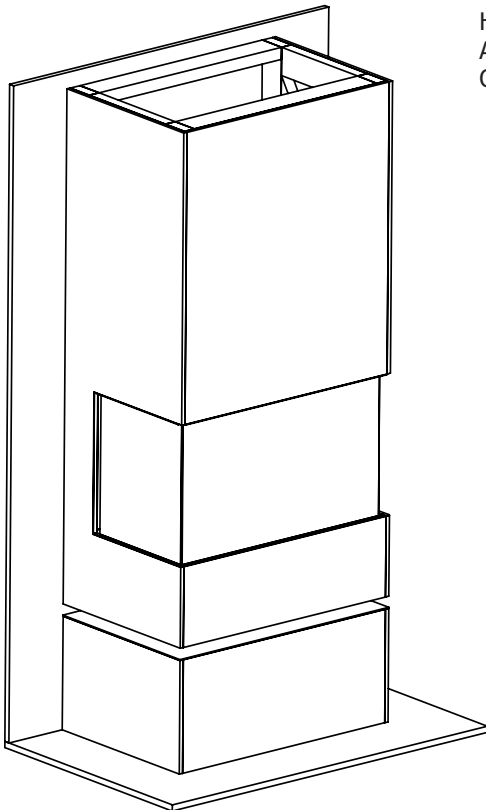
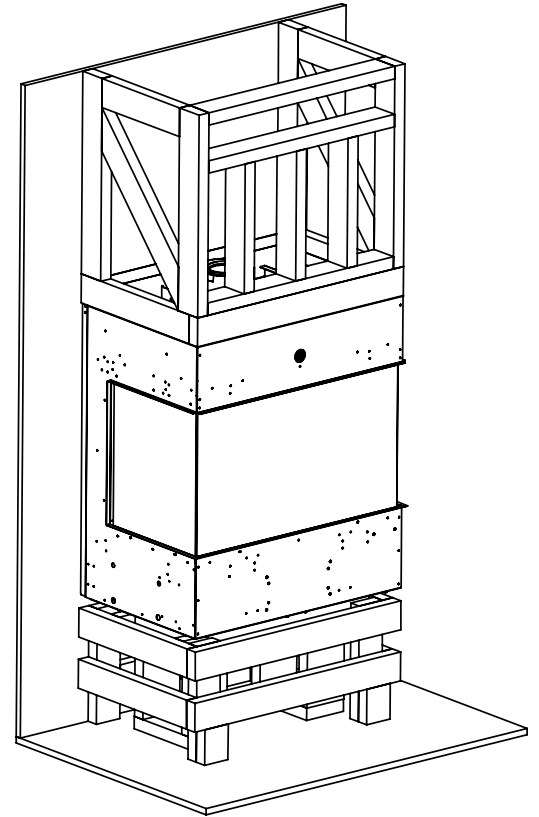

HEAT RELEASE: OPEN  
AIR INTAKE: TRADITIONAL  
ON PEDESTAL

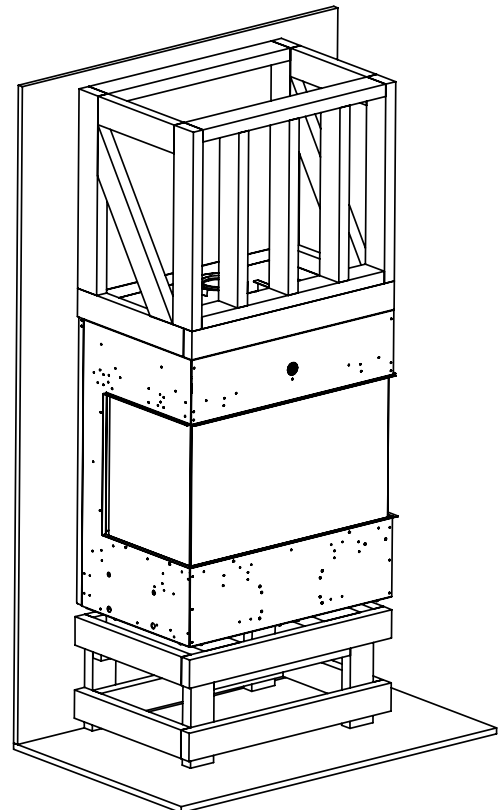

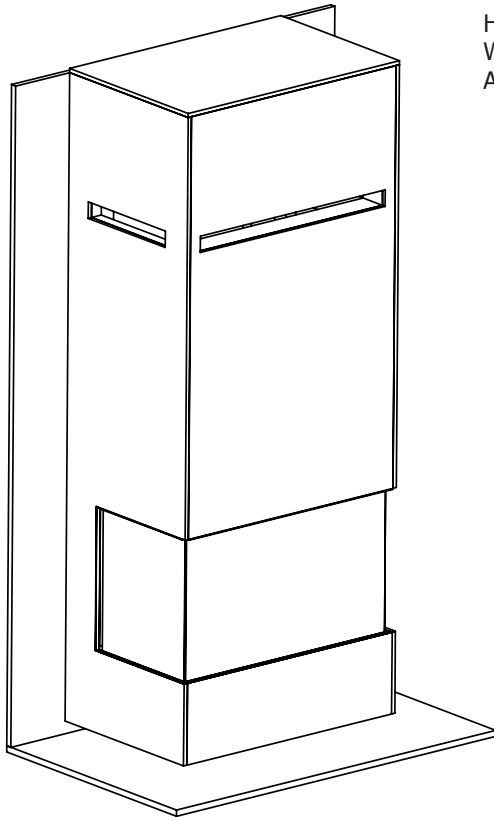

HEAT RELEASE: TRADITIONAL  
WITH FALSE CEILING  
AIR INTAKE: TRADITIONAL

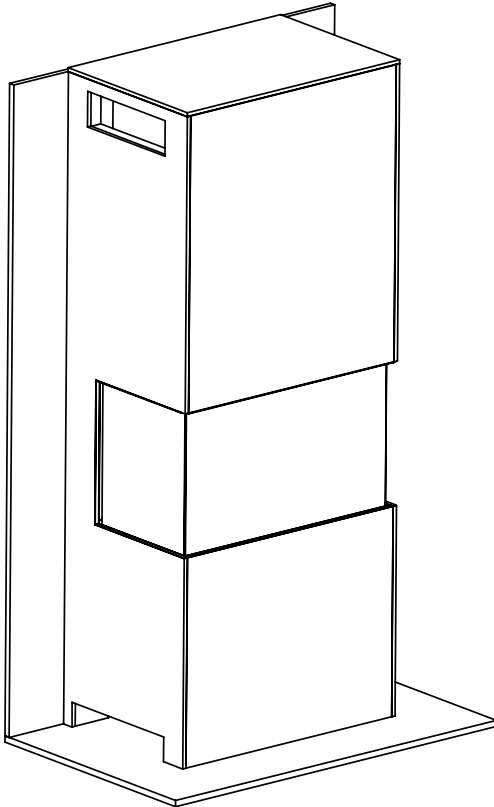
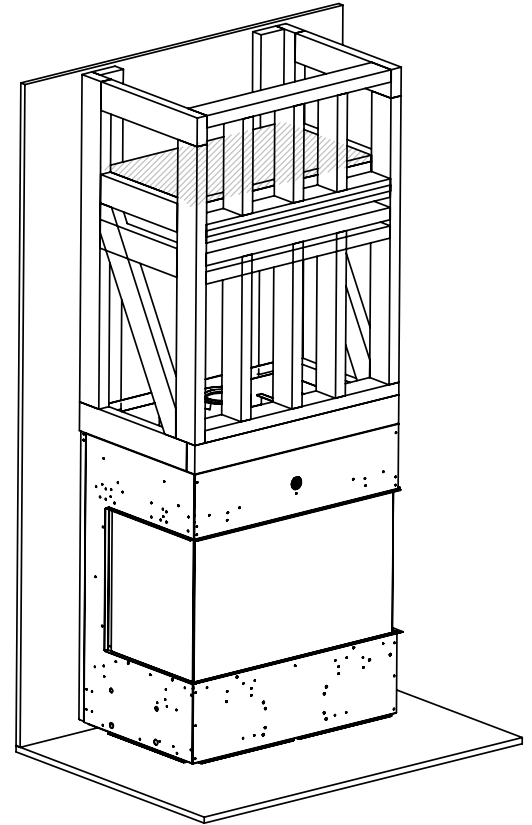

HEAT RELEASE: SIDES ONLY  
AIR INTAKE: SIDES ONLY  
WITH PEDESTAL

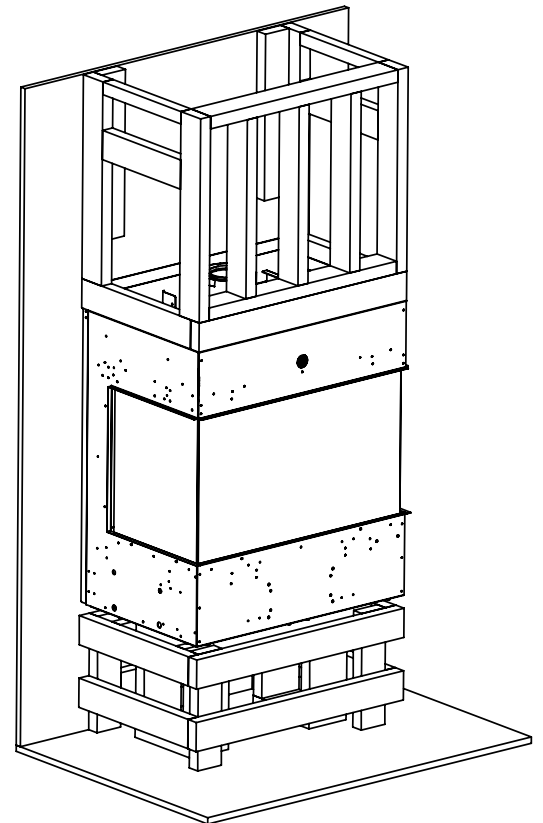

\*Framing illustrations are for example only and are not necessarily meant to be followed exactly.

#### Framing Pedestal

An optional pedestal can be added to any installation to raise the unit further off the floor. Minimum opening and pedestal dimensions must be followed to ensure safe heat dissipation. Combustible material is acceptable when constructing the pedestal.

The hatched area(s) must be left unobstructed in order for proper unit cooling. Do not cover these areas for any reason. Unit must sit on center blocks to hold the weight. The center portion can be a solid block, the space within the fireplace footprint can be used for support. Air cannot be drawn from the center area directly underneath. Hatched area(s) must add up to minimum required open area:

U50 = 135 sq. in.

U70 = 165 sq. in.

Framing shown is an example and can be constructed differently.

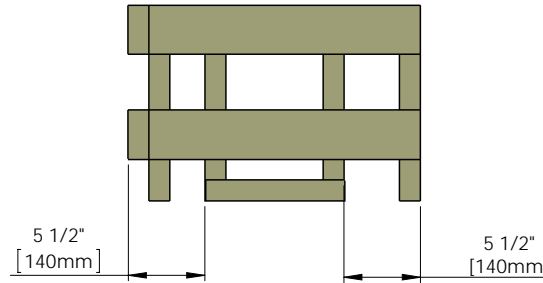
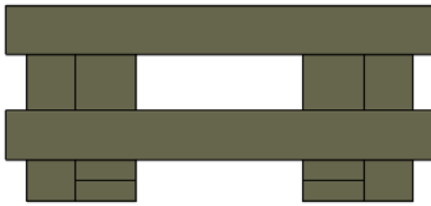
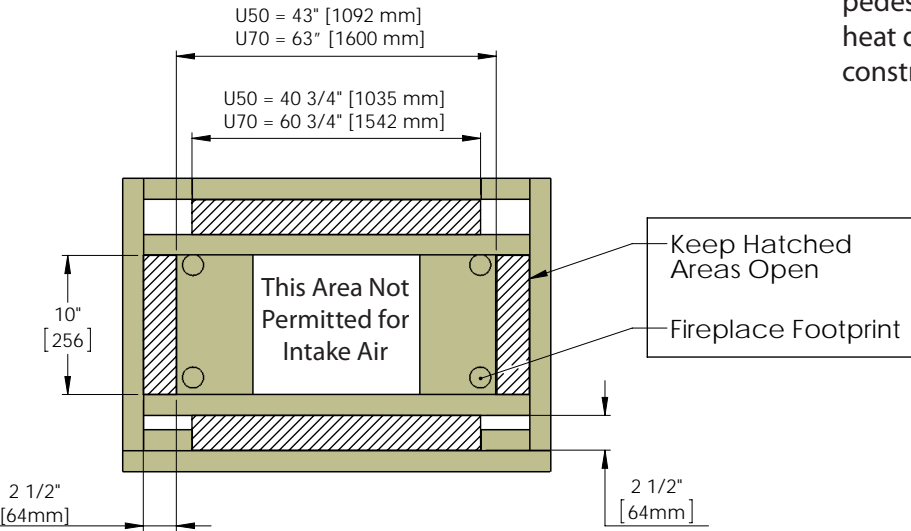

#### Framing Valance

An optional valance can be added to any installation to help conceal the heat release gap. Minimum opening and valance dimensions must be followed to ensure safe heat dissipation. Combustible material is acceptable when constructing the valance. Follow the minimum dimensions below

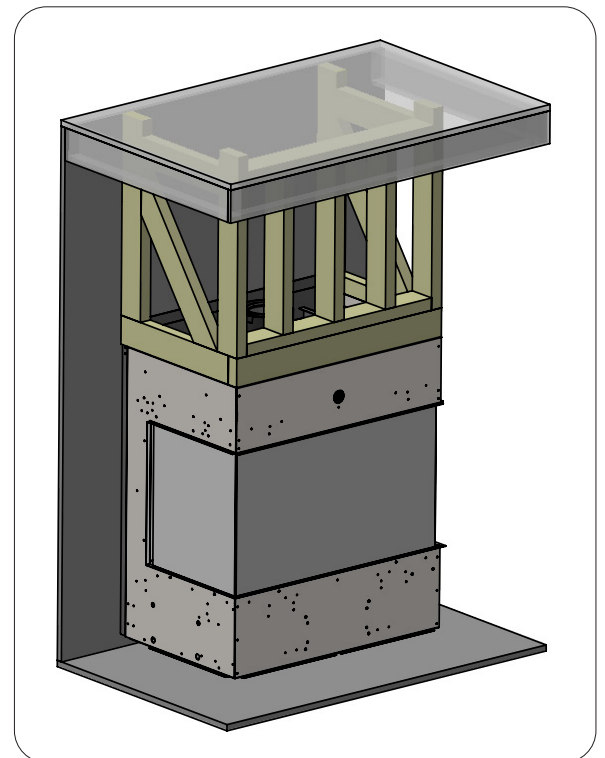
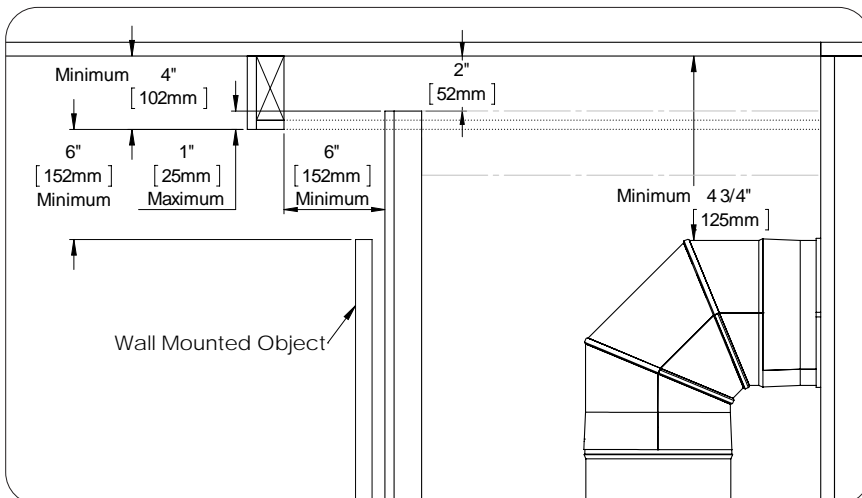



\*Framing illustrations are for example only and are not necessarily meant to be followed exactly.

Minimum intake dimensions must be taken at the fireplace cabinet, not the end of the hearth/plinth.

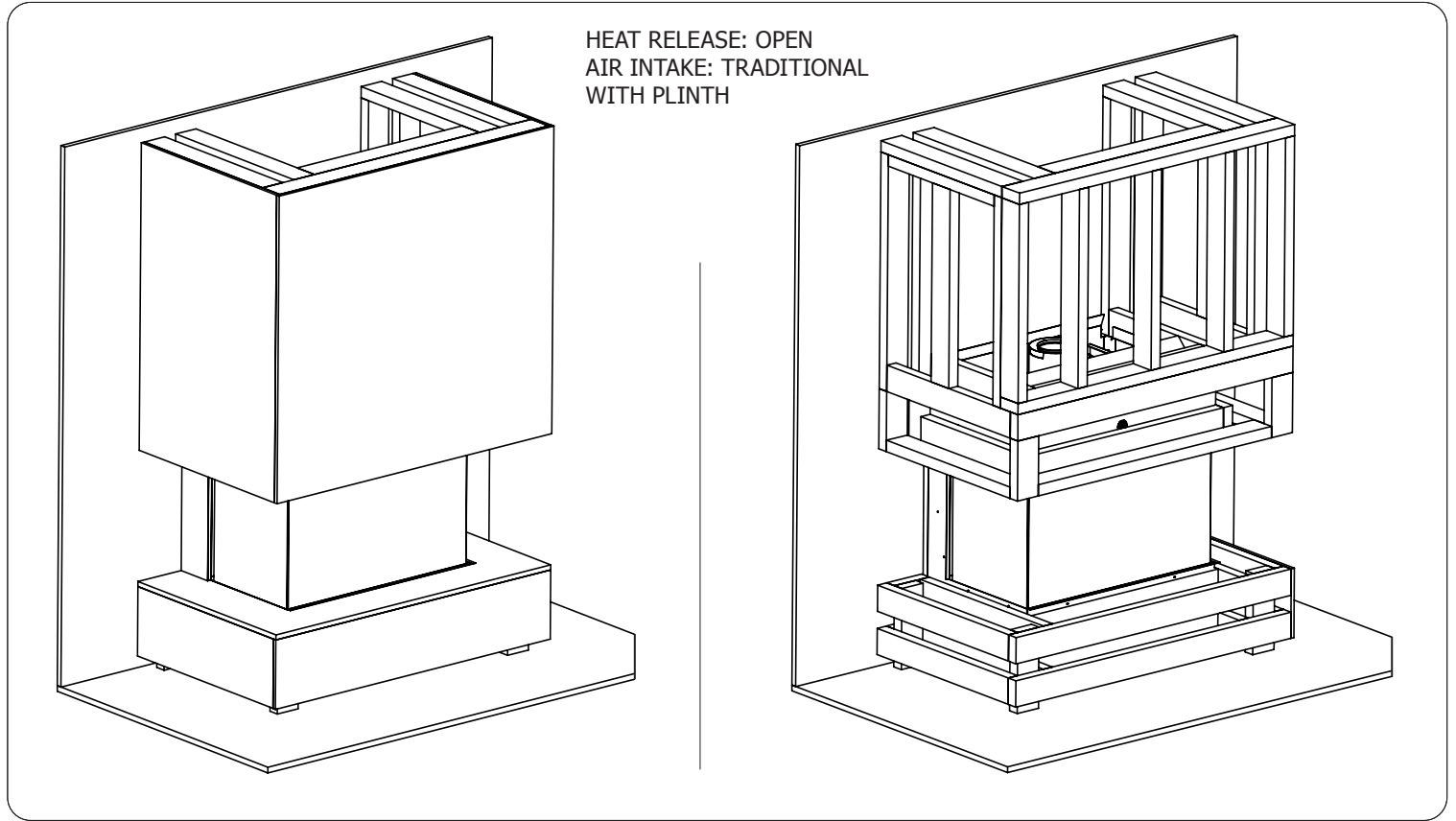

#### Framing Corner and Extension

Your fireplace can be framed into a corner using an optional kit. The kit will block off the side corresponding to the designation. Ex. left corner kit will block off the

left side of fireplace (shown below). The framed side wall can be adjacent to the unit, or it can extend indefinitely. If an extension is desired, an internal "false wall" must be constructed beside the unit within the enclosure to maintain chase draft geometry. All minimum air gaps must be adhered to. Air gaps that extend past the unit are NOT counted. This same logic applies to a hearth/plinth extended past the fireplace for a shelf or sitting area.

Corner kit has mandatory standoffs that must be installed. See corner kit instructions for further information.

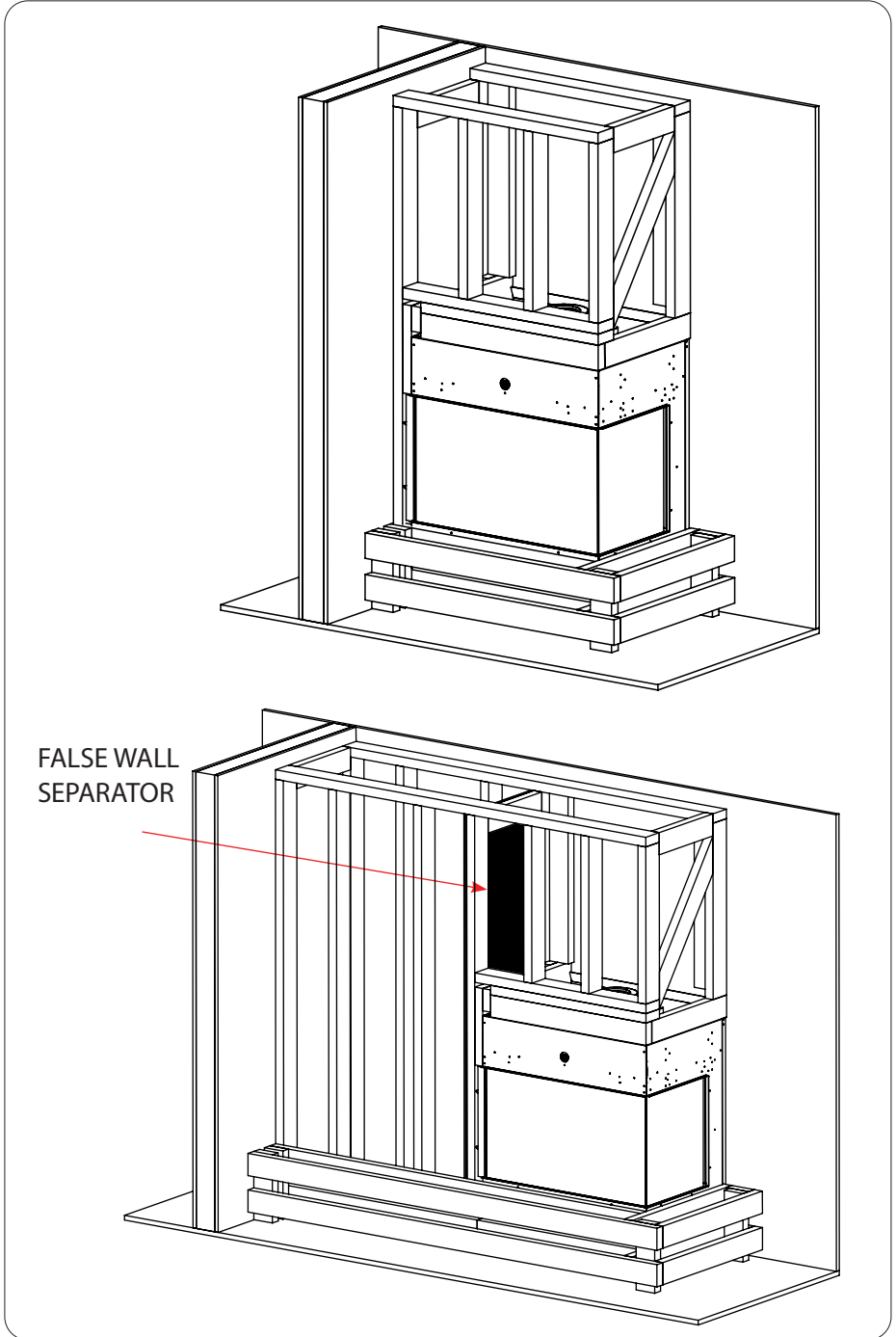
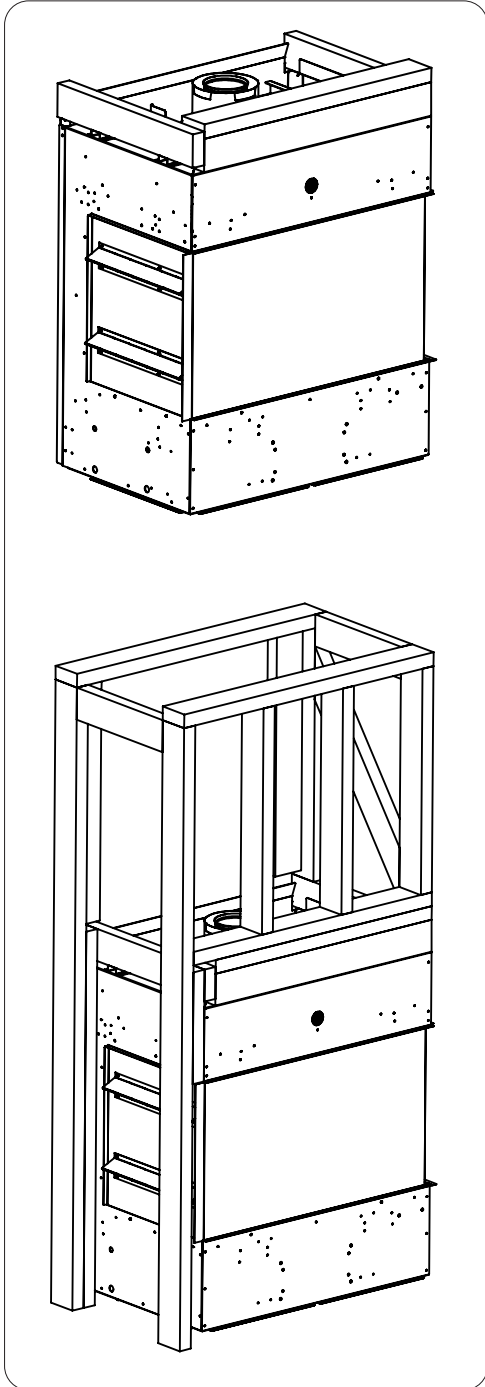

## Crawl Space / Basement Intake

Where approved by local codes and the house's HVAC supplier, the chase intake air may be supplied from a basement or conditioned crawl space below to achieve a hidden intake at the bottom of the chase.

- The basement or crawl space must be sealed from the outside and serviced by the house's HVAC system.
- No other appliances or fans within the house can be vented to the basement or crawl space.
- All direct vent appliances must be vented outside
- Floor cut out size must be at least minimum required open area.
- Floor cut out cannot be less than 1 1/2" (38mm) in width
- Floor cut out must be located directly below front fans. Two equally sized side cut outs are **not permitted**.
- The intake air must be directly supplied from the cut out below.
- Intake air **cannot** be supplied using venting and **cannot** be connected to existing HVAC ducting
- This installation **is not permitted** if a B-Vent or solid fuel appliance/fireplace is installed in the same area the intake is drawing air from.
- This installation **is not permitted** for non-conditioned crawl spaces or basements vented to the outside.

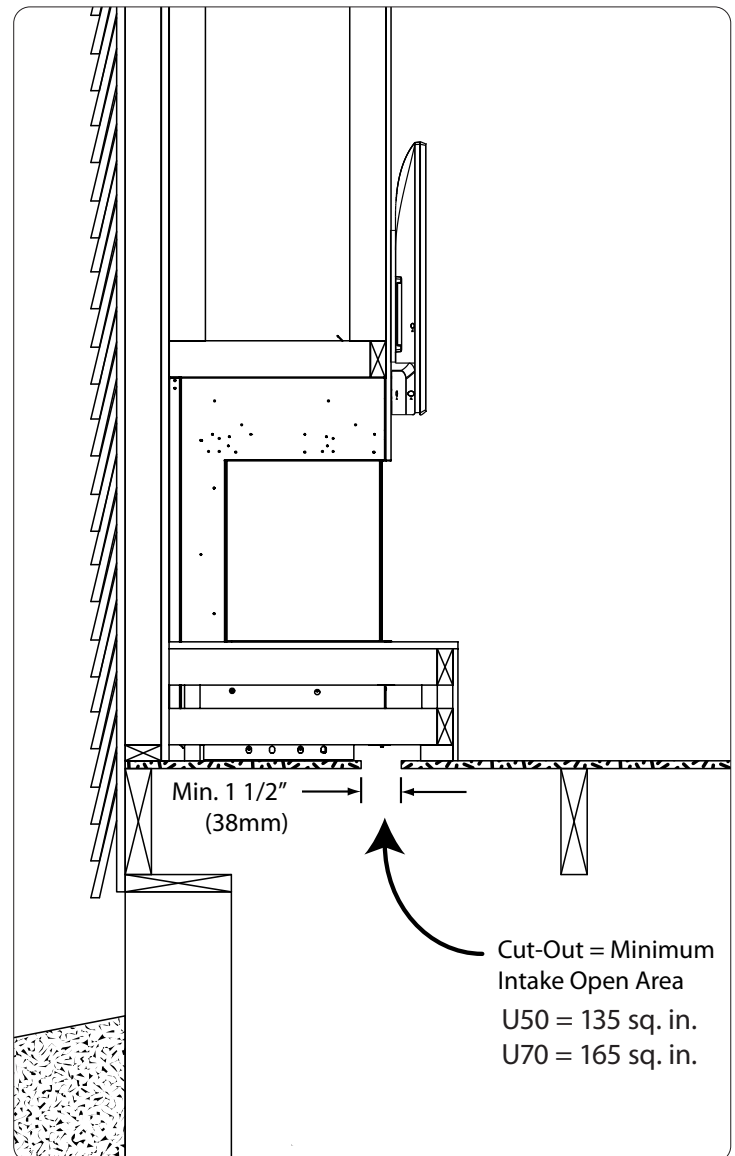
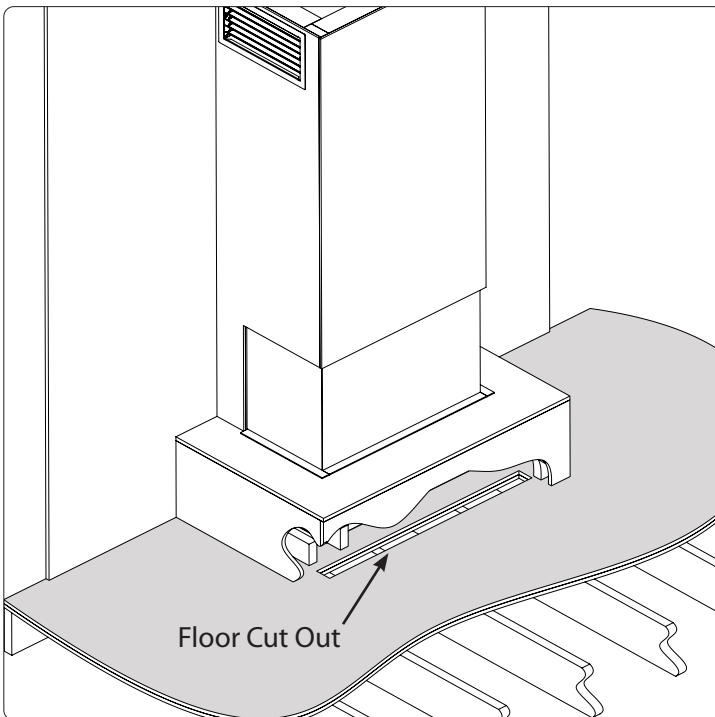

#### HDTV and Recess Clearances

If you're planning to mount a TV or artwork above the fireplace than some considerations must be made to ensure delicate objects are protected from heat. During testing temperatures did not exceed 50°F over ambient on the front exterior wall. There is no guarantee that these temperatures will not harm the longevity of your TV. Make sure to consult your TV manufacture's specifications to find the maximum allowable operating temperature. Since every home and installation is unique, temperatures should be verified at the time of install. The minimum permitted TV height may need to be increased to prevent the mounting screws from penetrating the fireplace cabinet.

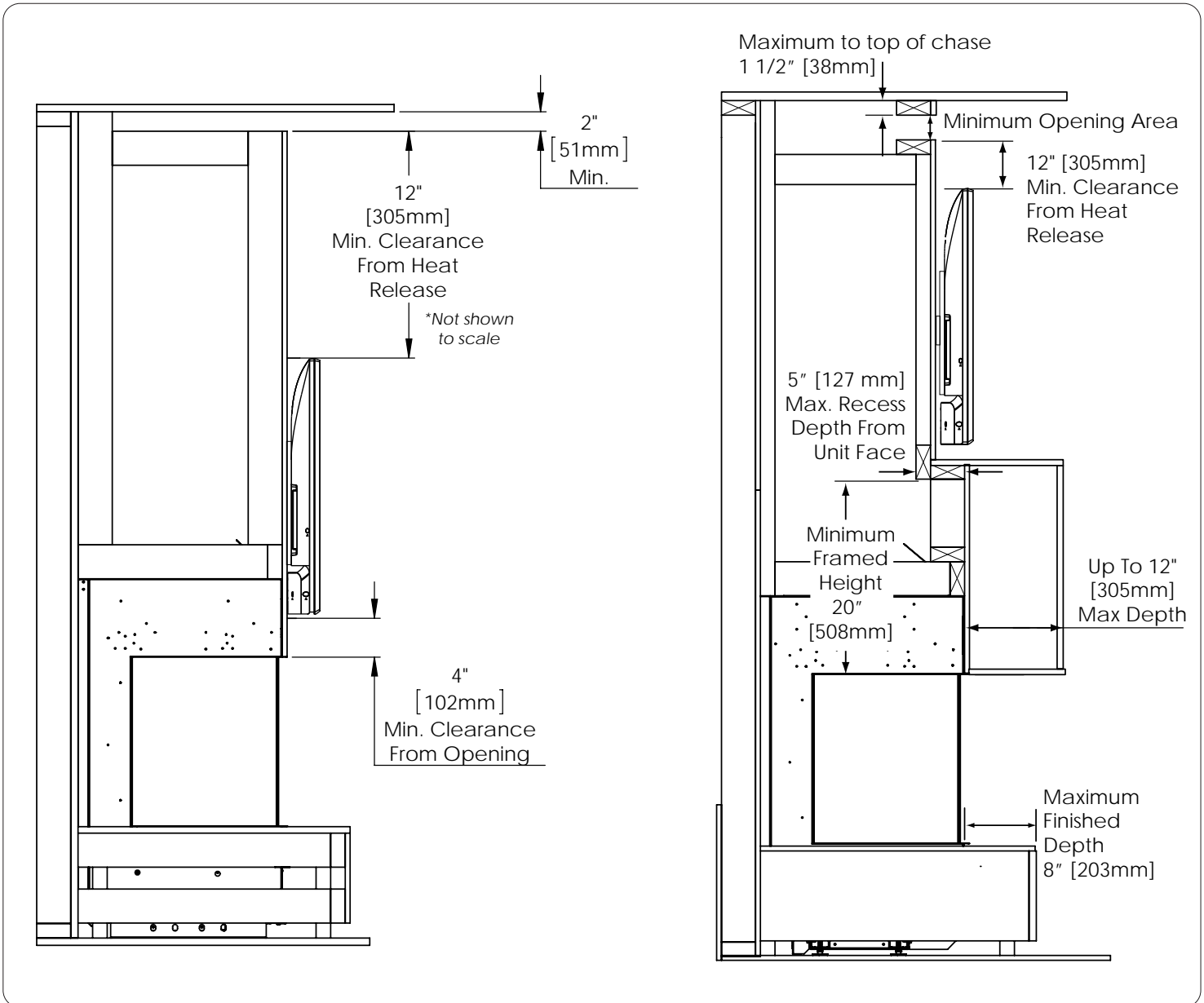

**Note on Media Cable Routing** - All wiring and cables should be routed along the inside front and side walls of the chase, well clear of venting or any part of the fireplace. During testing internal side and front wall surface temperatures, at least 20" above the top of the fireplace opening, did not exceed the rated temperature limits of rigid PVC conduit or System 636® CPVC.

## Finishing Fascia (Optional)

The fireplace is supplied with an optional 3-piece steel finishing fascia (item #9, page 8) that installs around the perimeter of the outer glass for a cleaner finish. To install the fascia pieces simply place them on top of the bottom tiling edges and glue them to the hearth surface using construction adhesive. Confirm the front corners are flush and square prior to the adhesive setting. If desired, the fascia pieces may also be painted to colour match the hearth. High temperature paint is not required.

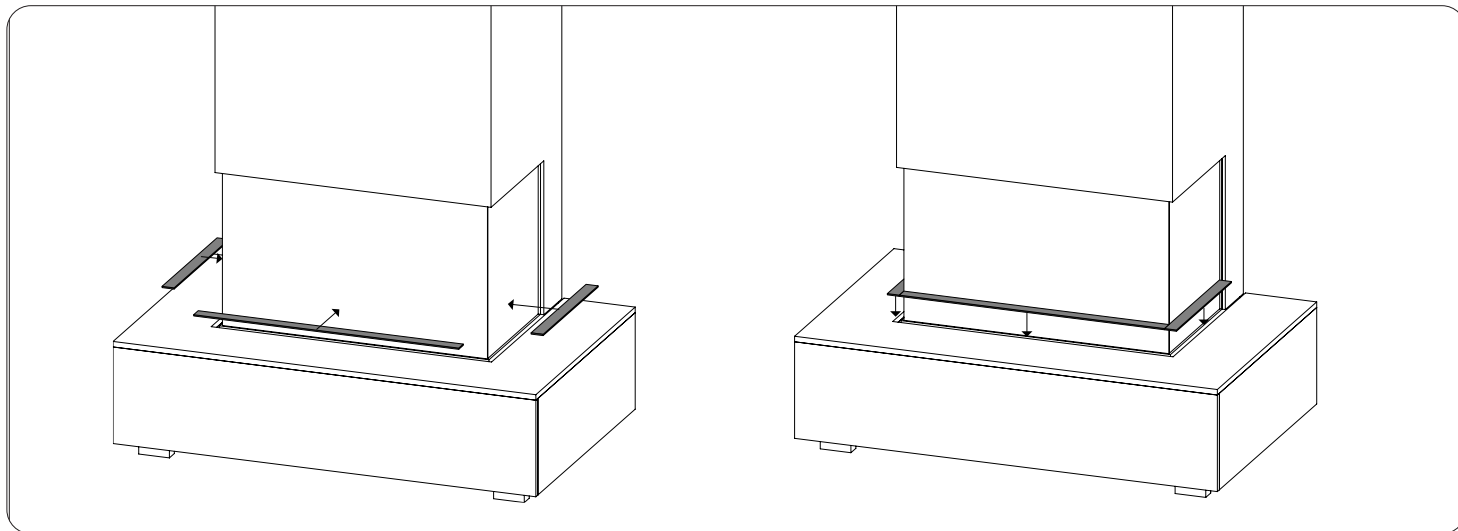

### Venting Introduction:

Your fireplaces can operate using a natural vent or power vent system (50-3883).

Natural Vent (Rigid): 5" X 8" venting system

Natural Vent (Flex): 5" X 8" aluminum flex venting system

Power Vent: 4" x 6 5/8" rigid vent or 3" x 5" Duravent CVS

See power vent kit for further information.

Follow the venting instructions for safe and proper operation of the appliance. Deviation from the minimum vertical length can create difficulty in burner start-up and sooting.

Allow several minutes for the flame to stabilize after ignition under extreme vent configurations. It is recommended for vent lengths that pass through unheated spaces (garages, attics, crawl spaces) be insulated to minimize condensation. Use at least 3 screws at each vent connection. Check periodically that the vents are unrestricted, especially the exterior vent cap.

Venting Considerations:

1. A power vent system should be considered for extreme weather areas (wind, cold).
2. 36" minimum vertical rise before an elbow does not apply to power vent units.
3. Flex venting is intended for use with simple vent configurations.
4. Use a snorkle termination for more draft (if needed).

**WARNING:**

- **Follow venting instructions exactly for safe and proper appliance operation.**
- **Use aluminum tape for all venting connections.**
- **Risk of fire, explosion, or asphyxiation if improper venting setup.**
- **Risk of fire, do not allow loose materials or insulation to contact vent pipe. Remove insulation to allow installation of thimble and maintain clearances to combustible materials.**

## Vent Termination Restrictions

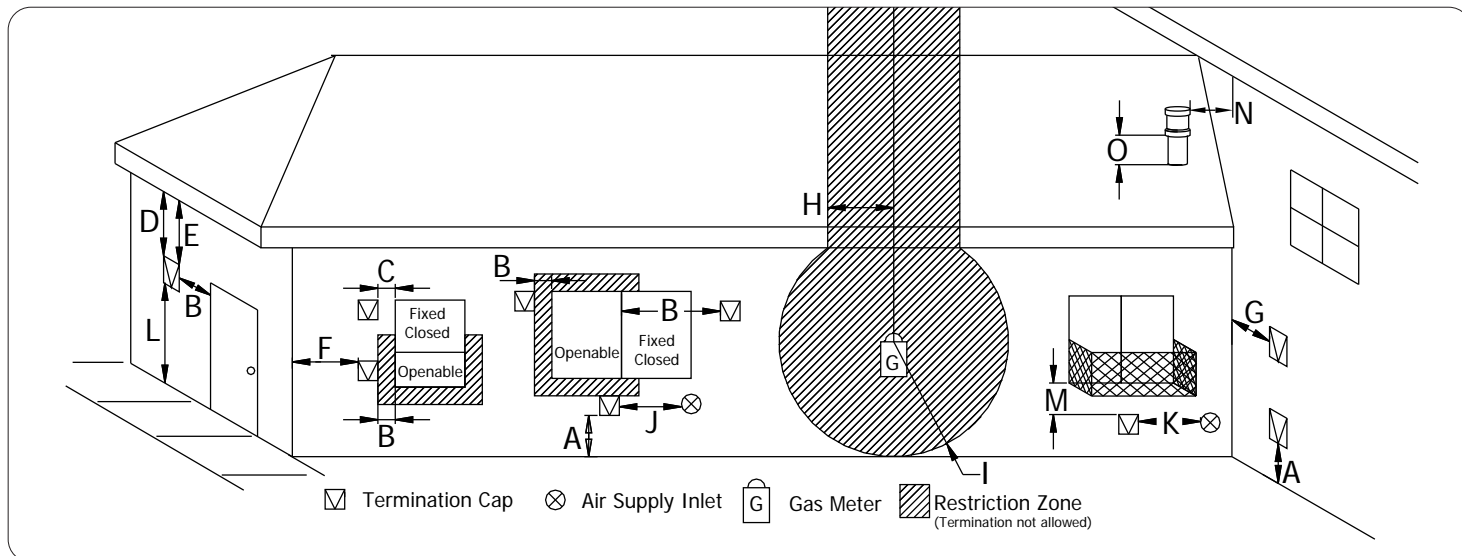

|   | Canadian Installation <sup>1</sup>   | US Installation <sup>2</sup>  | Description  |
|---|--|---|--|
| A | 12 in (30 cm)  |   | Clearance above grade, verandah, porch, deck, or balcony.  |
| B | 12 in (30 cm)  | 9 in (23 cm)  | Clearance from window or door that may be opened.  |
| C | 12 in (30 cm)*   |   | Clearance from permanently closed window (to prevent condensation).  |
| D | 24 in (60 cm)  |   | Vertical clearance to ventilated soffit located above the terminal, within a horizontal distance of 2 ft (60 cm) from center line of terminal. |
| E | 24 in (60 cm)  |   | Clearance to unventilated soffit.  |
| F | 12 in (30 cm)*   |   | Clearance to outside corner.   |
| G | 12 in (30 cm)  |   | Clearance to inside corner.  |
| H | 3 ft (91 cm) within a height of 15 ft (4.5 m) above the meter/regulator assembly | 3 ft (91 cm) within a height of 15 ft (4.5 m) above the meter/regulator assembly* | Clearance to each side of center line extended above meter/regulator assembly.   |
| I | 3 ft (91 cm)   | 3 ft (91 cm)*   | Radial clearance around service regulator vent outlet.   |
| J | 12 in (30 cm)  | 9 in (23 cm)  | Clearance to non-mechanical air supply inlet to building, or the combustion air inlet to any other appliance.                                  |
| K | 6 ft (1.83 m)  | 3 ft (91 cm) above if within 10 ft (3 m) horizontally                             | Clearance to mechanical air supply inlet.  |
| L | 7 ft (2.13 m) <sup>t</sup>   | 7 ft (2.13 m) <sup>*t</sup>   | Clearance above paved sidewalk or paved driveway located on public property.   |
| M | 24 in (60 cm) <sup>+</sup>   |   | Clearance under verandah, porch, deck, or balcony.   |
| N | 12 in (30 cm)*   |   | Clearance horizontally to any surface (such as an exterior wall) for vertical terminations.  |
| O | 12 in (30 cm)  |   | Clearance above roof line for vertical terminations.   |

<sup>1</sup> In accordance with the current CSA B149.1, Natural Gas and Propane Installation Code.

<sup>2</sup> In accordance with the current ANSI Z223.1 NFPA 54, National Fuel Gas Code.

\* These numbers are only estimates.

<sup>t</sup> A vent shall not terminate directly above a side walk or paved driveway that is located between two single family dwellings and it serves both dwellings.

<sup>+</sup> Permitted only if verandah, porch, deck, or balcony is fully open on a minimum of two sides beneath the floor.

| Roof Pitch          | Minimum Height (H) |        |
|---------------------|--------------------|--------|
|                     | Feet               | Meters |
| Flat to 7/12        | 1                  | 0.3    |
| Over 7/12 to 8/12   | 1.5                | 0.46   |
| Over 8/12 to 9/12   | 2                  | 0.61   |
| Over 9/12 to 10/12  | 2.5                | 0.76   |
| Over 10/12 to 11/12 | 3.25               | 0.99   |
| Over 11/12 to 12/12 | 4                  | 1.22   |
| Over 12/12 to 14/12 | 5                  | 1.52   |
| Over 14/12 to 16/12 | 6                  | 1.83   |
| Over 16/12 to 18/12 | 7                  | 2.13   |
| Over 18/12 to 20/12 | 7.5                | 2.29   |
| Over 20/12 to 21/12 | 8                  | 2.44   |

### Vertical Termination

1. Check venting clearances and termination restrictions for required clearances to combustibles when passing through ceilings, walls, roofs, enclosures, attic rafters, or other nearby combustible surfaces. Do not pack air spaces with insulation.
2. Set the fireplace in the desired location. Drop a plumb bob down from the ceiling to the fireplace flue exit and mark the location where the vent will penetrate the ceiling. Drill a small hole at this point. Next, drop a plumb bob from the roof to the hole and mark the spot where the vent will penetrate the roof. Determine if ceiling joists, roof rafters, or other framing will obstruct the venting system. Relocate the fireplace or offset the venting to avoid cutting load bearing members.
3. To determine the length of pipe required, measure room height, ceiling thickness, and vertical rise in an attic or second story. Firestops are required at each floor level beyond the first floor ceiling support/wall thimble cover or cathedral ceiling support box. If an offset is required to avoid obstructions, use a pair of 45 degree elbows. For proper support, use elbow straps with offsets. Use wall straps for long vertical runs. Attic insulation shield is required in attic.
4. Measure roof pitch. Select the proper flashing and storm collar and determine the height above the roof (see Table). A non-corrosive pipe material must be used for all exterior pipe lengths. Seal nail heads with silicone.

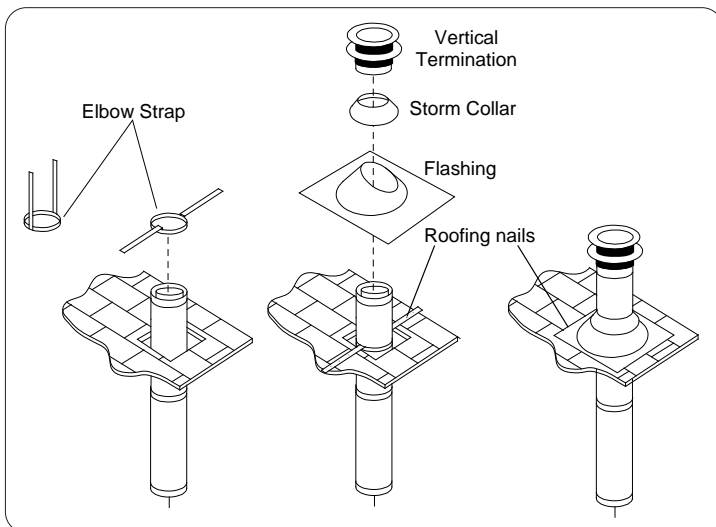
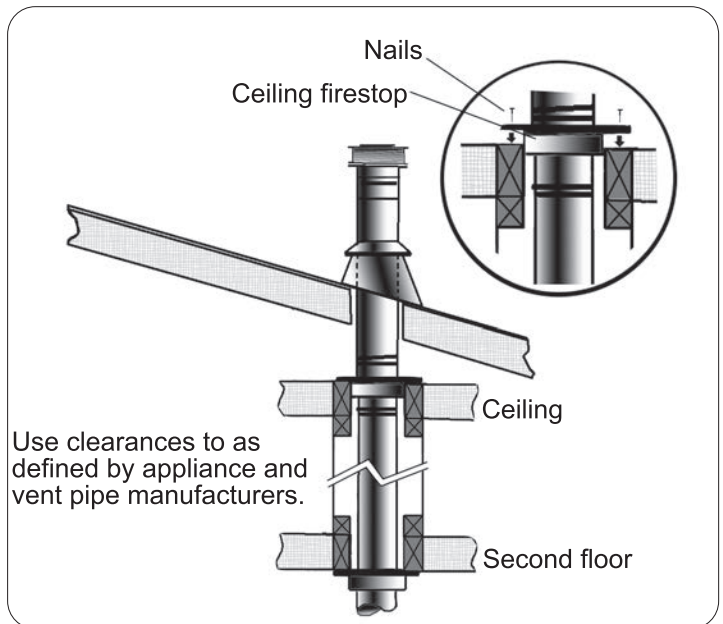
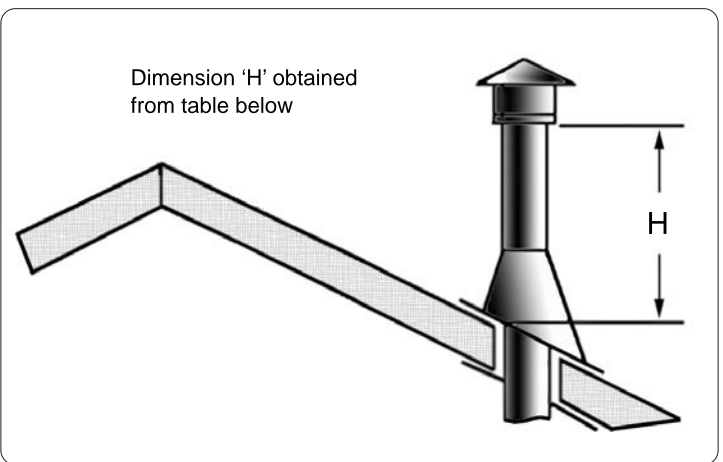



**NOTES:**

1. If an offset is necessary in the attic to avoid obstructions, it is important to support the vent pipe every 3' (914 mm) using wall straps to avoid excessive stress on the elbows.
2. Use 45° degree elbows instead of 90° degree elbows when ever possible. The 45° degree elbow offers less restriction to the flow of flue gases and intake air.

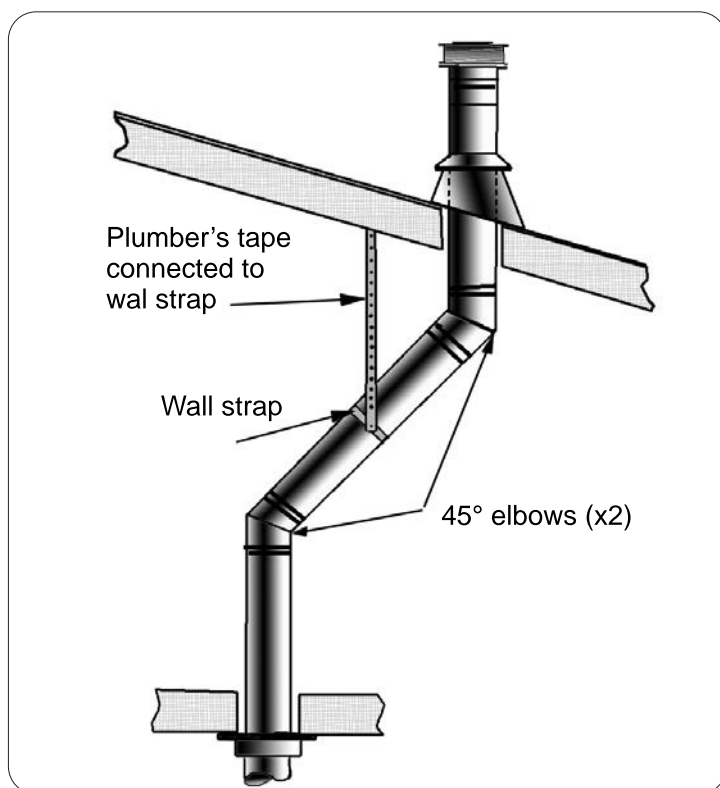
**Horizontal Termination:**

**1. A minimum 3ft vertical section before an elbow is required when horizontally terminating with an approved venting cap.**

**2. Horizontal pipes must not be level. For every 12" (305 mm) of horizontal travel there should be at least 1/4" (6.4 mm) of vertical rise. Never allow the vent to run downward, as this could cause high temperatures or even present the possibility of a fire.**

**3. The exterior of the horizontal vent termination must not be blocked or obstructed.**

**4. If the vent termination is not being attached to wood, the four wood screws provided should be replaced with material appropriate fasteners.**

**5. For buildings with vinyl siding, a vinyl standoff should be installed between the vent cap and**

the exterior wall. Attach the vinyl siding standoff to the horizontal termination. The termination attaches to the flat portion of the standoff which provides an air space between the wall and the vent termination. The air gap prevents excessive heat from possibly melting the vinyl siding.

**6. Horizontal pipes must be supported every 3' (914 mm). Plumber's "all round" strap will suffice.**

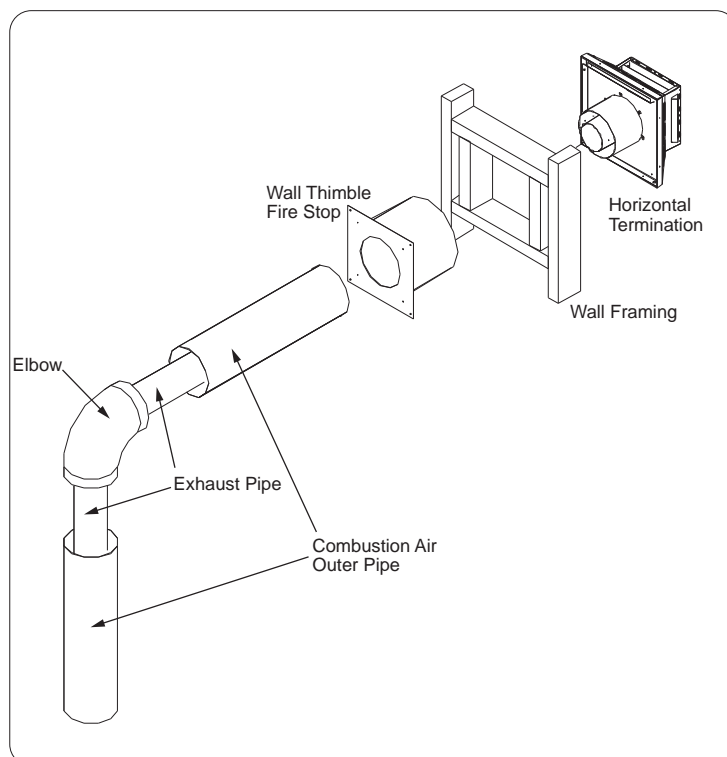

**7. Clearances to combustibles must be maintained when running horizontal pipe. 1" (25 mm) sides, 1" (25 mm) bottom, 3" (76 mm) top, and 3" (76 mm) above elbows outside the immediate chase.**

**8. Set the fireplace in the desired location. Check to determine if wall studs will be in the way when the venting system is attached. If this is the case, the location of the fireplace may have to be adjusted or the venting may have to be offset.**

**9. Many direct vent pipe sections are designed with special twist-lock connections. Dry fit the desired combination of pipe and elbows to the appliance adaptor.**

**10. With the pipe in the correct position and attached to the fireplace, mark the wall for a hole as directed by specified wall thimble dimensions. Cut and frame the hole in the exterior wall where the vent will be terminated. If the wall being penetrated is made of a non-combustible material (i.e. masonry or concrete) a minimum 7 1/2" (191mm) hole is acceptable.**

### Venting Clearances

Clearances must be in accordance with local installation codes and requirements of the gas supplier.

**NOTE: Venting terminals shall not be recessed into walls or siding. Horizontal venting terminals, other than ICC EXCELDirect 5HT, must have a 1 1/2" (38 mm) clearance from the finished exterior wall surface. Use M&G Duravent Part #58DVA-VSS. This clearance DOES NOT apply to non-cumbustible building finishes such as stone, brick and cement fiber siding i.e. HardiePlank®.**

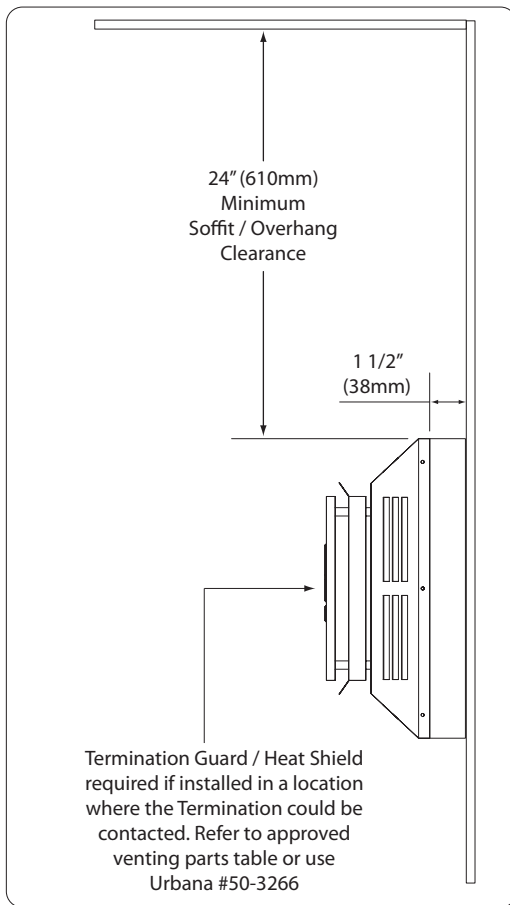

**HORIZONTAL TERMINATIONS FOR LED MODELS** - For optimum performance Duravent Direct Vent Pro and Selkirk Direct-Temp models are recommended.

**Termination restrictions and clearances do not apply when power venting. Refer to power vent installation manual.**

**-This gas appliance must be direct vented and can't be connected to a chimney flue serving a separate solid-burning appliances.**

**Clearances to combustibles must be maintained around all vent pipes.**

| Minimum Vent Clearances           |                         |
|-----------------------------------|-------------------------|
| Vertical Pipe to Studs            | 1" (25mm)<br>all around |
| Above Horizontal Pipe             | 3"<br>(76 mm)           |
| Horizontal Pipe<br>Sides & Bottom | 1"<br>(25 mm)           |
| Above First Elbow                 | See below               |
| Above Additional Elbows           | 3"<br>(76 mm)           |

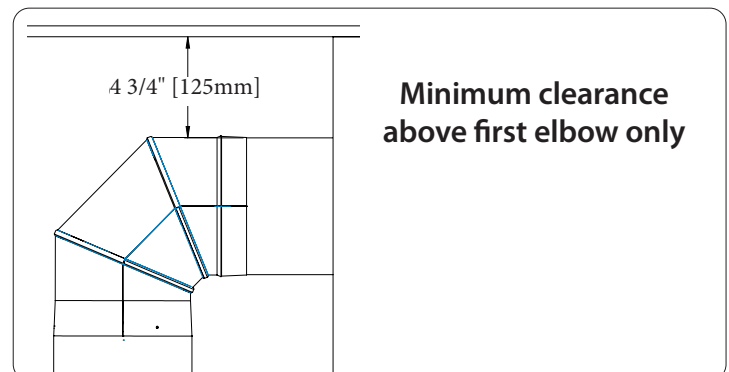
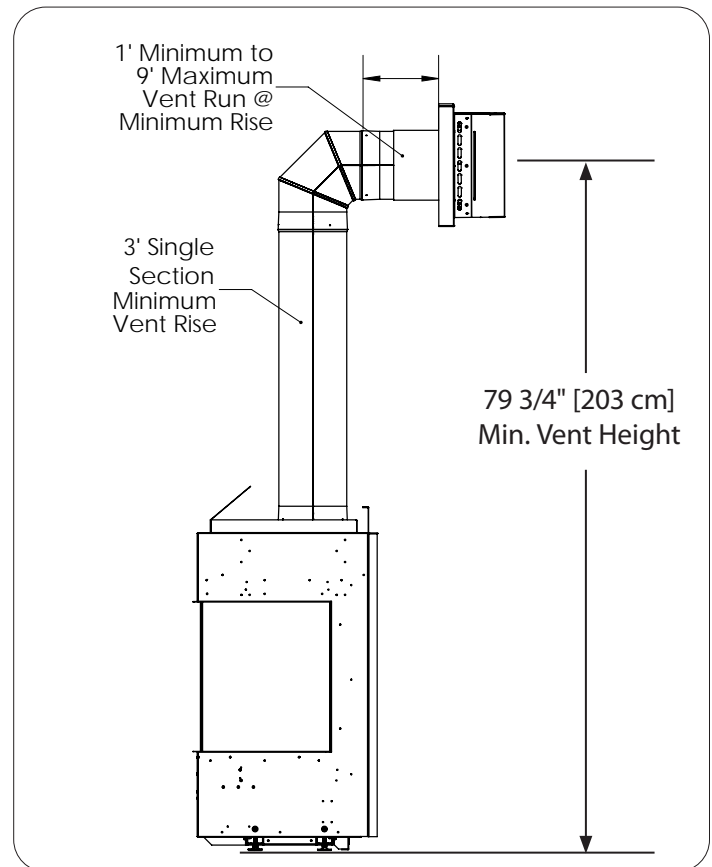

## Wall / Ceiling Thimble

Use a wall thimble when passing through an exterior wall or ceiling. Typically the framing hole will be 10 1/2" x 10 1/2" but each thimble manufacturer may vary. Installations in Canada require a wall thimble be used but they are recommended for all installations. All sealing and vapour barriers must comply with local building codes.

Use a firestop when passing through interior joints of subsequent floors.

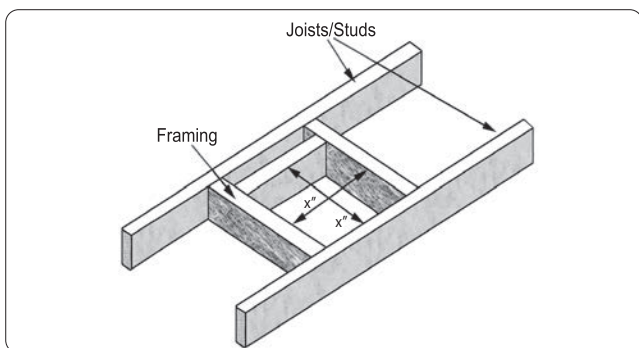

## Approved Rigid Venting

| Manufacturer  | Trade Name      | Nominal Sizes |
|---------------|-----------------|---------------|
| ICC           | EXCELDirect     | 5" x 8"       |
| M&G Dura-Vent | Direct Vent Pro | 5" x 8"       |
| Selkirk       | DIRECT-TEMP     | 5" x 8"       |
| Selkirk       | AMP DV          | 5" x 8"       |

Refer to the table below for part numbers of commonly used parts for approved venting systems. Please visit the respective manufacturers' website for more information.

**WARNING: Do not mix parts from different vent manufacturers' systems.**

**EXCEPTION TO WARNING:** This product has been evaluated by Intertek using a DirectVent Pro starting collar in conjunction with other venting manufacturers. Using the DirectVent Pro starting collar is deemed acceptable and does not affect the Intertek listing of the appliance.

| Direct Vent Pro       | EXCELDirect | DIRECT-TEMP | AMV DV         | Description                        |
|-----------------------|-------------|-------------|----------------|------------------------------------|
| 58DVA-06              | 5DL6        | 5DT-06      |                | 6" pipe length                     |
|                       |             |             | 5D7            | 7" pipe length                     |
| 58DVA-09              | 5DL9        | 5DT-09      |                | 9" pipe length                     |
| 58DVA-12              | 5DL1        | 5DT-12      | 5D12           | 12" pipe length                    |
| 58DVA-18              |             | 5DT-18      |                | 18" pipe length                    |
| 58DVA-24              | 5DL2        | 5DT-24      | 5D2            | 24" pipe length                    |
| 58DVA-36              | 5DL3        | 5DT-36      | 5D3            | 36" pipe length                    |
| 58DVA-48              | 5DL4        | 5DT-48      | 5D4            | 48" pipe length                    |
| 58DVA-60              |             |             |                | 60" pipe length                    |
| 58DVA-E30             |             |             |                | 30° elbow, black                   |
| 58DVA-E45             | 5DE45       | 5DT-EL45    | 5D45L          | 45° elbow, black                   |
| 58DVA-E90             | 5DE90       | 5DT-EL90    | 5D90L          | 90° elbow, black                   |
| 58DVA-VSS, DVA-BVS    | VSS         | 5DT-VS/VSK  | 5DHVS, DVSK    | Vinyl siding standoff/shield       |
| 58DVA-WT3, 58DVA-WTU3 | 5WT         | 5DT-WT      | 5DWT           | Wall thimble                       |
| 58DVA-SC              | SQSC, SC    | 5DT-SC      | 5DSC           | Storm collar                       |
| 58DVA-WFS             |             | 5DT-FS      |                | Wall Fire stop                     |
| 58DVA-FS              | 5CS         | 5DT-FS      | 5DFSP          | Ceiling Fire stop                  |
| 58DVA-IS              | 5AS         | 5DT-AIS     | 5DAIS12, AIS36 | Attic Insulation Shield            |
| 58DVA-WS              | 5WS         | 5DT-WS/B    | 5DWS           | Wall strap/support/band            |
| 58DVA-VCH             | 5SVT        |             |                | High wind vertical termination     |
| 58DVA-HC              | 5HT         | 5DT-HC      | 5DHCS          | High wind horizontal termination   |
| 46DVA-WG              | HTS         |             | 4DHW           | Wind / Heat Shield                 |
| 58DVA-17TA            |             |             |                | 11" to 17" pipe, adjustable        |
| 58DVA-24TA            |             |             |                | 17" to 24" pipe, adjustable        |
|                       | 5DLA30      |             |                | 16.5" to 29" pipe, adjustable      |
|                       | 5DLS1       |             |                | 1 7/8" to 9" slip length pipe      |
|                       | 5DLS2       |             |                | 1 7/8" to 21" slip length pipe     |
| 58DVA-F6              | 6EFA        | 5DT-AF6     | 5DF            | Flashing, 0/12 to 6/12 roof pitch  |
| 58DVA-F12             | 6EFB        | 5DT-AF12    | 5DF12          | Flashing, 7/12 to 12/12 roof pitch |
| 58DVA-FF              | 6EF         |             |                | Flat Roof Flashings                |
| 58DVA-CFK             | 4MF         |             |                | Masonry Flashing                   |

A snorkel is permitted for use on installations where additional vertical rise is required on the exterior of the building. Refer to the table below for the approved models. Note, the use of a snorkel does not reduce the minimum required venting or termination clearances.

| Manufacturer  | Trade Name      | Model #                    |
|---------------|-----------------|----------------------------|
| ICC           | EXCELDirect     | ST14<br>ST36               |
| M&G Dura-Vent | Direct Vent Pro | 58DVA-SNK14<br>58DVA-SNK36 |
| Selkirk       | DIRECT-TEMP     | 5DT-ST14<br>5DT-ST36       |

### Flex Venting:

This fireplace is certified to work with aluminium co-axial flex venting. Flex venting can be used in the same configurations as rigid pipe, see venting diagram for details. Flex venting is only to be used for the run, it must be adapted to rigid piping for exterior wall penetration and termination. **Note: Adhere to all rigid venting safety measures and clearances.**

Use 5X8 Flex Adapter Kit [50-3789]: This kit will allow you to adapt co-axial flex to the fireplace, make your vent run, then adapt back to rigid venting (**flex not included**).

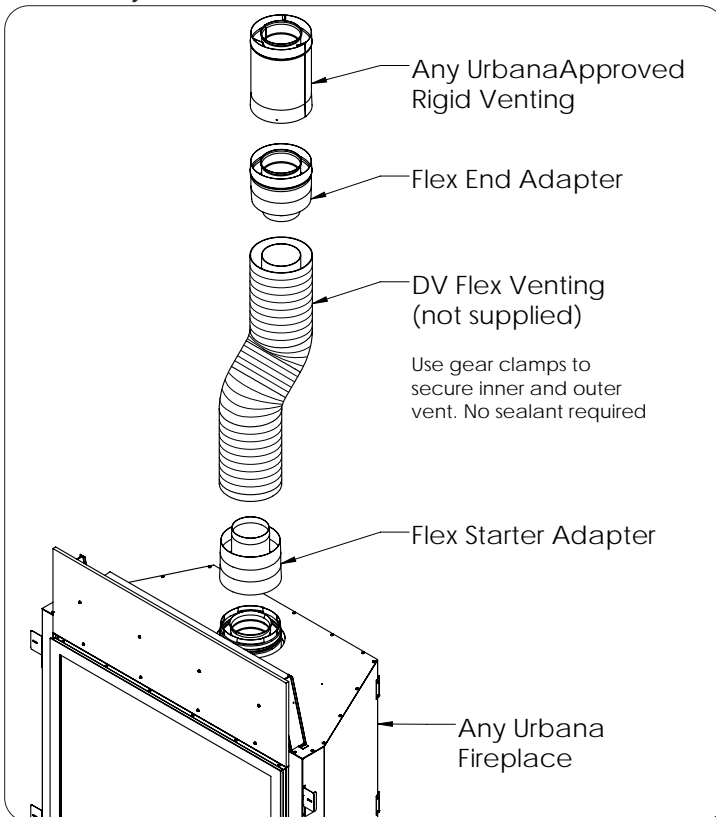

### NOTES:

- Do not bend flex vent over 90 degrees.
- All horizontal runs should have a minimum 1/4" (6mm) rise per foot for optimal performance.
- Do not allow the inner flex pipe to contact the outer pipe, keep it pulled tight and use spacer springs.
- Spacers are required at the start, middle, and end of each elbow to ensure gap is maintained.
- Do not add any extensions to the preset kits, if more length is required, use rigid pipe.
- No need for liquid sealant; secure flex venting with aluminum vent tape and apply sufficient self-tapping screws.

### Approved Flex Venting:

Any 5X8 CSA or UL flue gas certified aluminum or stainless steel flex is acceptable. Proper spacers must be used to keep pipes from contacting each other. Proper venting spacers must be used. Nothing makeshift. Examples of allowable flex pipe brands include: but are not limited to the following:

- M&G Duravent
- Selkirk Corp
- ICC
- Z-Flex
- Flexmaster
- Chim Flex
- Olympia
- BDM
- Metal-Fab

**Only the flex venting and spacers are needed. You must use the flex adapter kit and a certified rigid pipe termination cap.**

## Approved Venting Configurations (NG) :

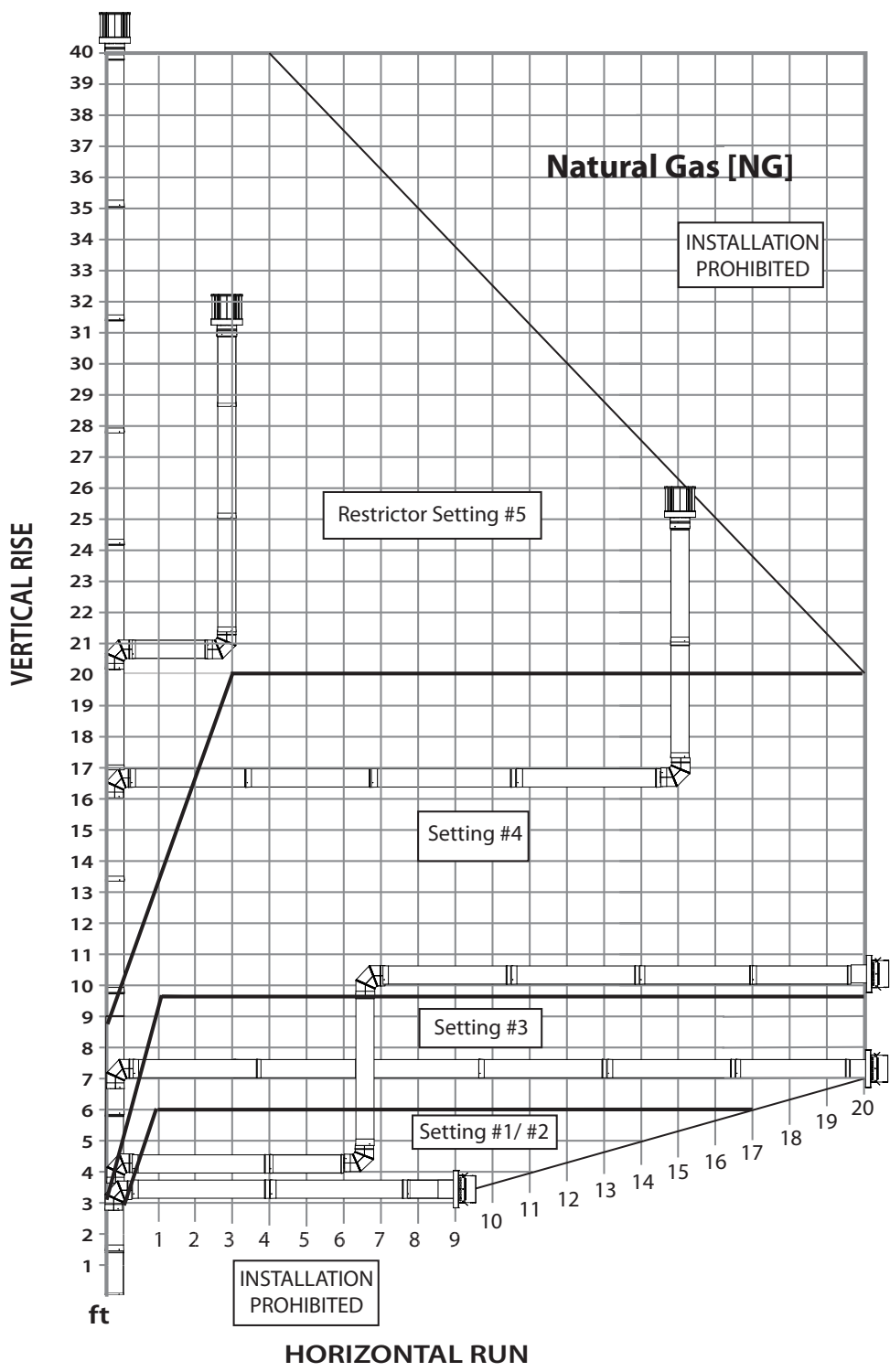

This shows the range of venting options using either vertical or horizontal terminations; any layout that remains within the shaded area is acceptable. Having the fewest number of elbows is ideal as they restrict air movement.

Any combination of rise and run can be used as long as it lays within the shaded area.

A maximum of three (3) 90° elbows or six (6) 45° elbows can be used.

90° elbows in the horizontal plane account for 3 horizontal feet (91.4cm) to your venting run. 45° elbows account for 1½ feet (45.7cm).

**Restrictor Setting:** Find the point on the graph where your vent configuration will terminate.

Remember to consider elbows in the HORIZONTAL plane account for horizontal distance as stated above.

Use the corresponding exhaust restrictor setting indicated on the graph. See the following section in this manual for restrictor details. Your climate and altitude may alter what restrictor is required for your particular application.

Note - LED models may require a lower restrictor setting than what is shown on the vent graph. Adjust as needed for desired flame appearance.

**Does your vent configuration fall outside the limits?** Use our power vent kit (50-3883) for a much broader venting range.

### Approved Venting Configurations (LP) :

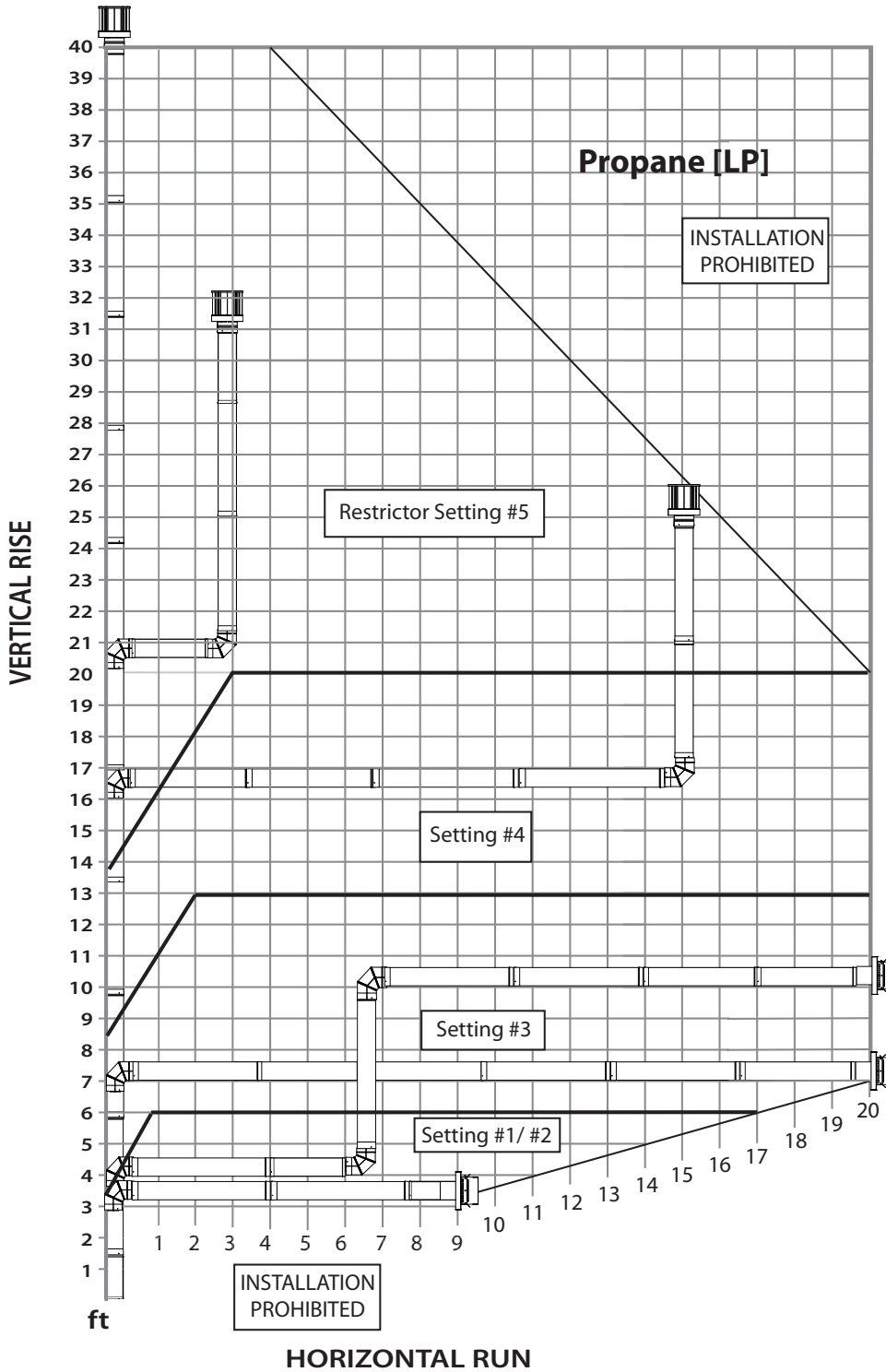

This shows the range of venting options using either vertical or horizontal terminations; any layout that remains within the shaded area is acceptable. Having the fewest number of elbows is ideal as they restrict air movement.

Any combination of rise and run can be used as long as it lays within the shaded area.

A maximum of three (3) 90° elbows or six (6) 45° elbows can be used.

90° elbows in the horizontal plane account for 3 horizontal feet (91.4cm) to your venting run. 45° elbows account for 1½ feet (45.7cm).

**Restrictor Setting:** Find the point on the graph where your vent configuration will terminate.

Remember to consider elbows in the HORIZONTAL plane account for horizontal distance as stated above.

Use the corresponding exhaust restrictor setting indicated on the graph. See the following section in this manual for restrictor details. Your climate and altitude may alter what restrictor is required for your particular application.

Note - LED models may require a lower restrictor setting than what is shown on the vent graph. Adjust as needed for desired flame appearance.

**Does your vent configuration fall outside the limits?** Use our power vent kit (50-3883) for a much broader venting range.

## Exhaust Restrictor Settings:

The restrictor disk is used to regulate draft and combustion air that leads to proper flame quality and appearance.

Climate, altitude, fuel-type, and vent configuration will depict which restrictor setting should be used. Use the vent graph to establish a starting point and adjust as necessary. The proper setting is crucial for an efficient burn and best possible flame appearance. Final adjustments should be made after running for 15-20 minutes. Consider that the flame will continue to grow as more time passes. Tune the air shutter (venturi) in conjunction with restrictor.

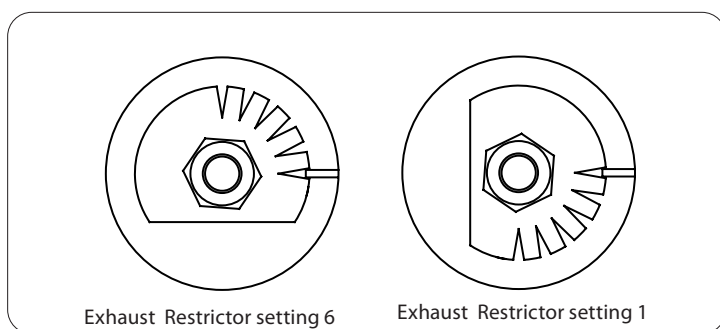

Rotate the dial counter-clockwise to increase the restriction level successively until the appropriate setting is achieved. When the flat edge is horizontal the restrictor level is at its maximum.

**WARNING: Improperly set restrictor setting can cause overheating issues which can lead to building fire.**

## Exhaust Restrictor Adjustment:

To adjust the exhaust restrictor, locate the access hole on the front of the unit.

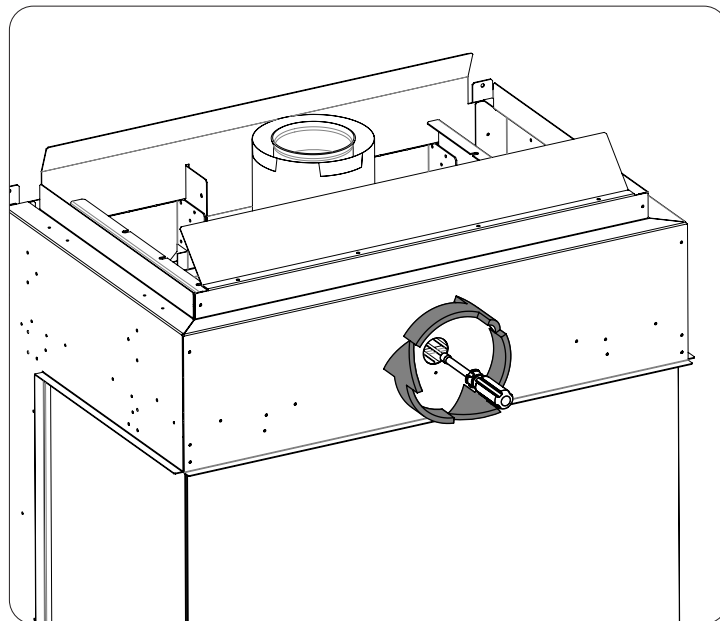

Use a 7/16 " socket with long extension to adjust the restrictor dial to desired setting.

Allow unit to warm up sufficiently and make adjustment as needed.

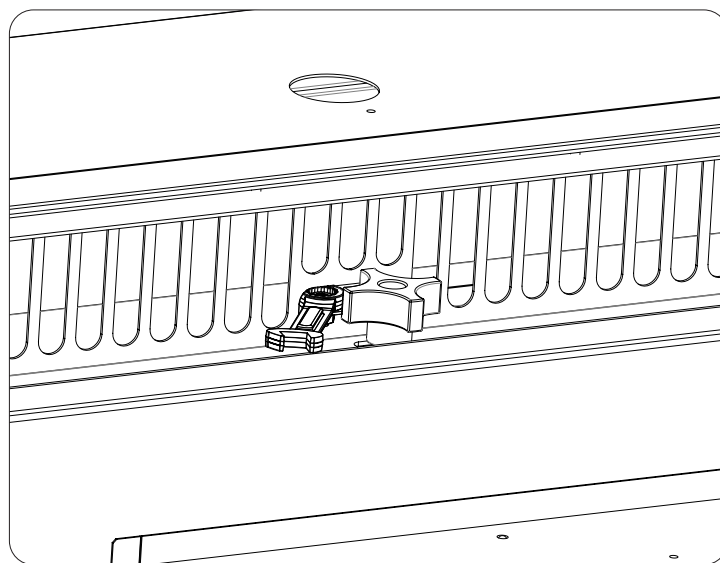

The restrictor dial can be accessed by removing the outer glass if the unit has already been finished into the wall.

1. Remove outer glass (see page 22).
2. Look up to see the cut-out in the steel to access the nut above the top glass clamp. Use a 7/16 wrench to make adjustments.

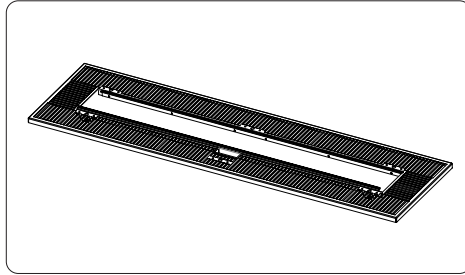
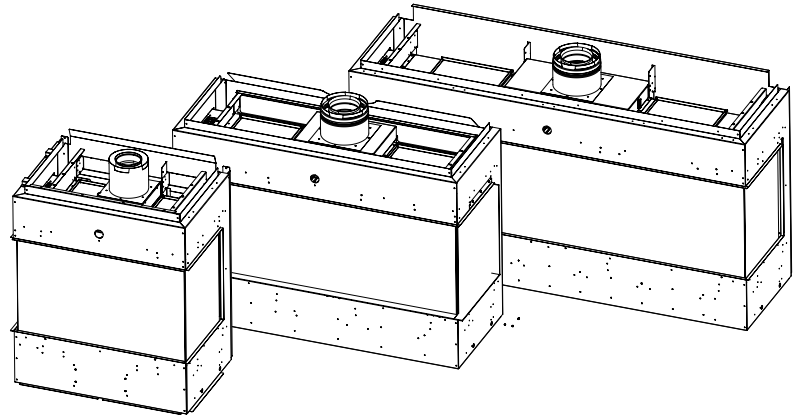

#50-3920 - U50 BURNER PLATFORM - LED

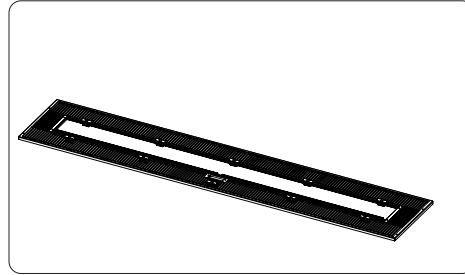

#50-3934 - U70 BURNER PLATFORM - LED

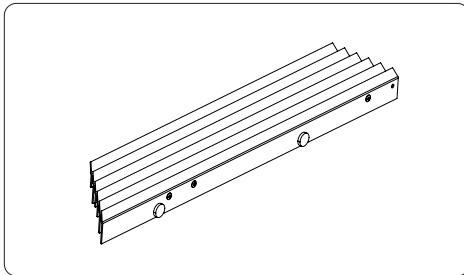

#50-3903 - RIGHT LOUVER ASSEMBLY  
PART USED IN ALL UNITS

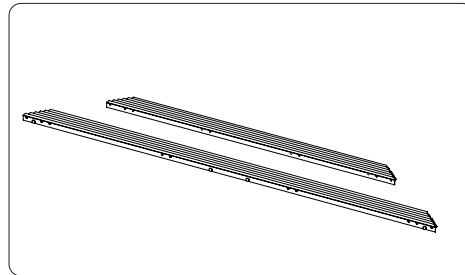

#50-3926 - U50 FRONT LOUVER ASSEMBLY  
#50-3940 - U70 FRONT LOUVER ASSEMBLY

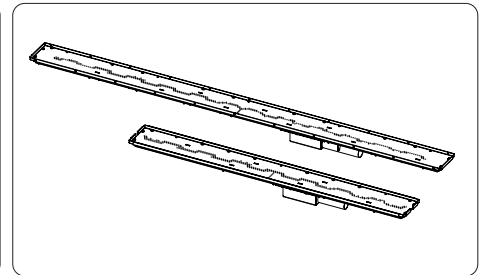

#50-3917 U50 BURNER (NG) / #50-3918 U50 (LP)  
#50-3931 U70 BURNER (NG) / #50-3932 U70 (LP)

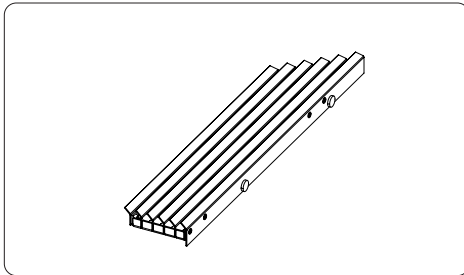

#50-3902 - LEFT LOUVER ASSEMBLY  
PART USED IN ALL UNITS

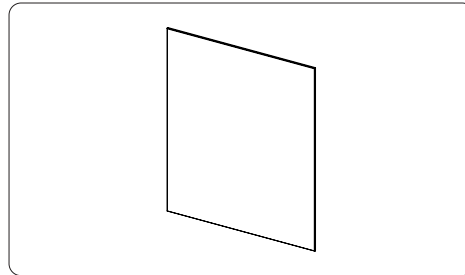

#50-3895 - URBANA OUTER SIDE GLASS  
PART USED IN ALL UNITS

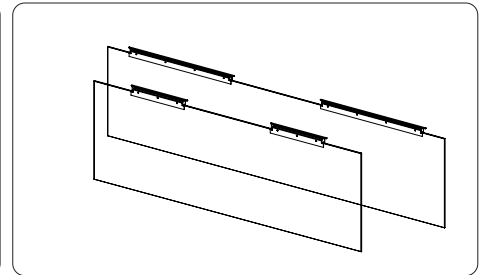

#50-3925 - U50 OUTER GLASS ASSEMBLY  
#50-3939 - U70 OUTER GLASS ASSEMBLY

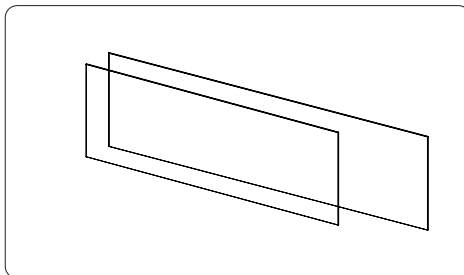

#50-3924 - U50 INNER FRONT GLASS  
#50-3938 - U70 INNER FRONT GLASS

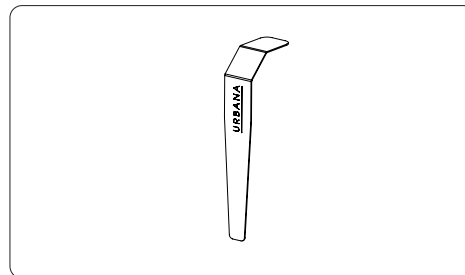

#50-3535 SWITCH TOOL  
PART USED IN ALL UNITS

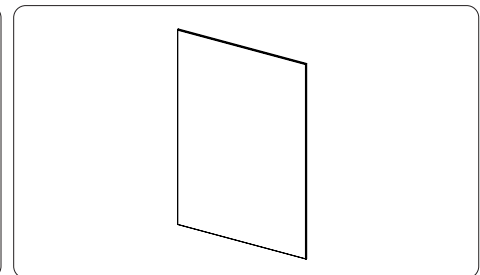

#50-3894 - URBANA INNER SIDE GLASS  
PART USED IN ALL UNITS



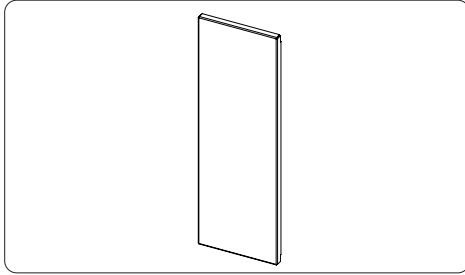

#50-3905 - STEEL SEGMENTED LINER (1 PCE.)  
PART USED IN ALL UNITS

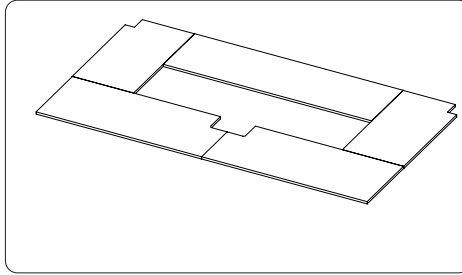

#50-3820 U50 INFINITY GLASS BEZEL- BLACK  
#50-3827 U70 INFINITY GLASS BEZEL - BLACK

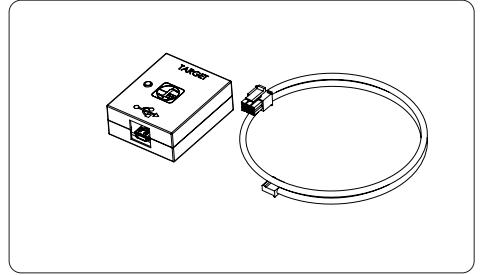

#50-3805 URBANA WIFI MODULE  
PART USED IN ALL UNITS

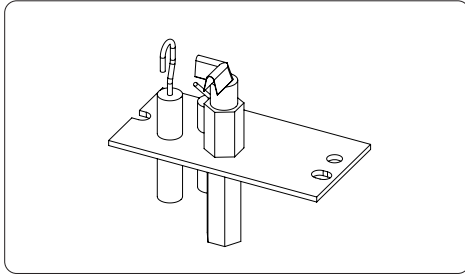

#50-3947 - U30 - IPI PILOT ASSEMBLY  
#50-3946 - U50/U70 - PILOT ASSEMBLY W/  
4FT LINE

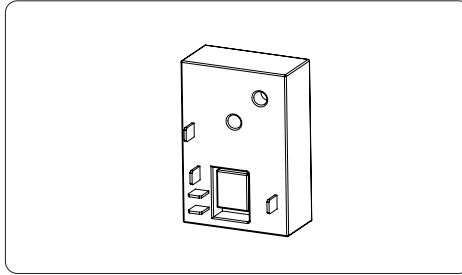

#50-3899 - TIMING RELAY  
PART USED IN ALL UNITS

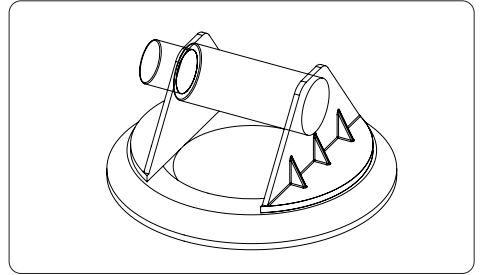

#50-3837 - SUCTION CUP HANDLE (1 PC)  
PART USED IN ALL UNITS

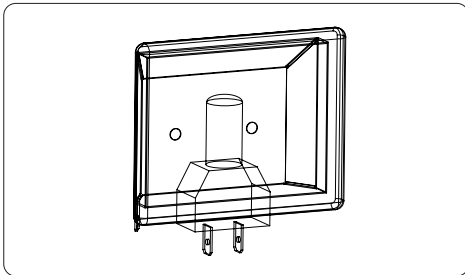

#50-3516 - EX/G/U SERIES TOP LIGHT  
ASSEMBLY  
PART USED IN ALL UNITS

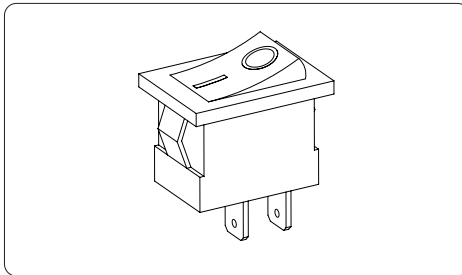

#50-3892 - URBANA ROCKER SWITCH  
PART USED IN ALL UNITS

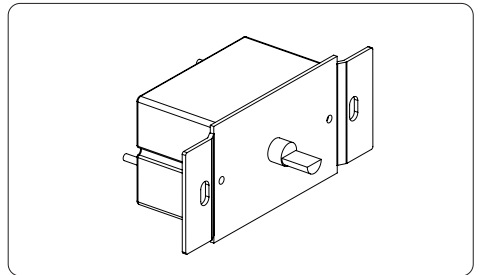

#50-3900 - FAN CONTROL RHEOSTAT  
PART USED IN ALL UNITS

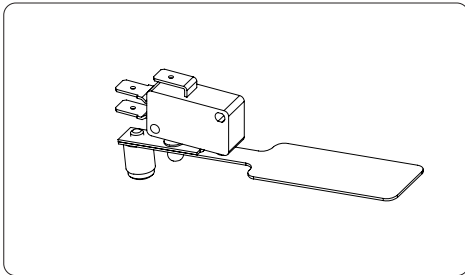

#50-3898 SAIL SWITCH ASSEMBLY  
PART USED IN ALL UNITS

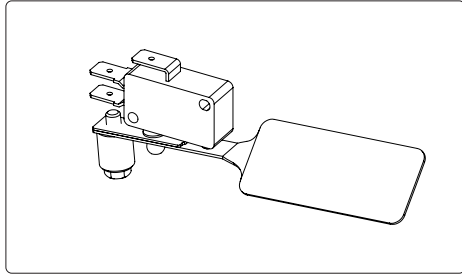

#50-3928 - U50/U70 CHASE SAIL SWITCH  
ASSEMBLY  
PART USED IN U50 U70

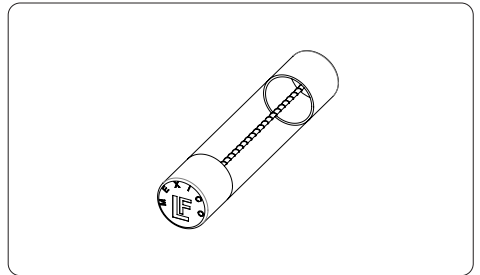

#50-2076 - 4 AMP FUSE  
PART USED IN ALL UNITS

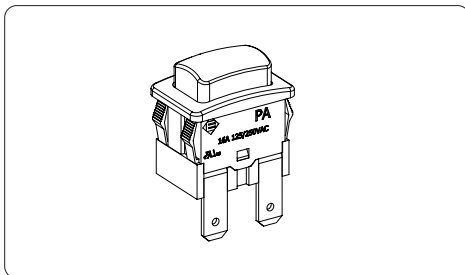

#50-3518 URBANA RESET BUTTON  
PART USED IN ALL UNITS

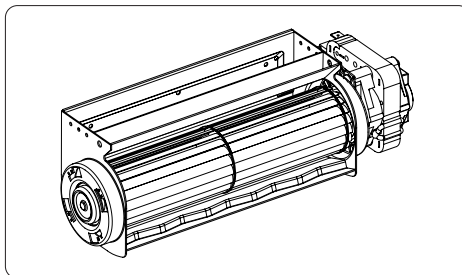

50-3901 - URBANA FAN  
PART USED IN ALL UNITS

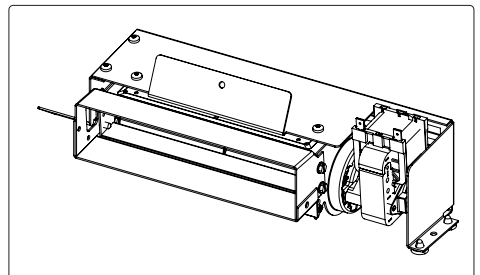

#50-3929 - U50/U70 CHASE FAN W/ MOUNT  
PART USED IN U50 U70

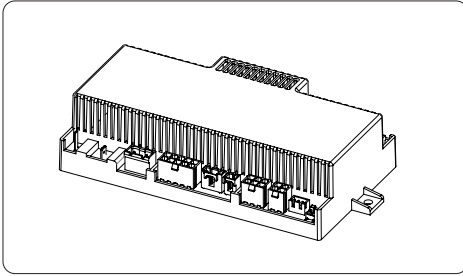

#50-3887 - PF2 WIFI READY IFC  
PART USED IN ALL UNITS

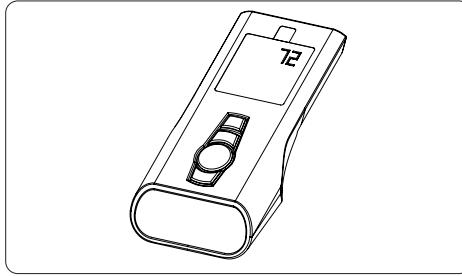

#50-3888 - PF2 WIFI READY TRANSMITTER  
PART USED IN ALL UNITS

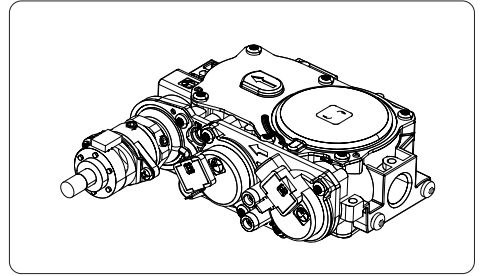

#50-2682 - SIT 885 VALVE W/ STEPPER MOTOR  
(NG)  
PART USED IN ALL UNITS

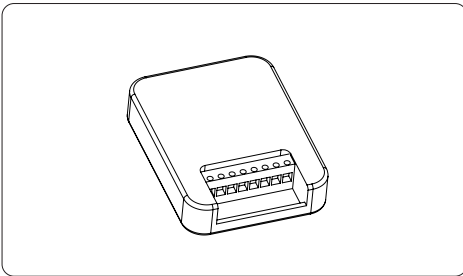

#50-3889 - LED WIFI CONTROLLER  
PART USED IN ALL LED UNITS

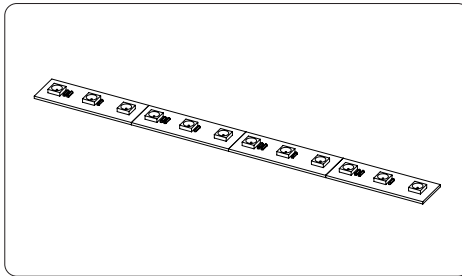

#50-3891 - LED LIGHTING STRIP  
PART USED IN ALL LED UNITS

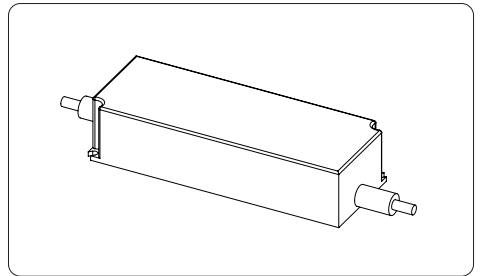

#50-3890 - LED DRIVER  
PART USED IN ALL LED UNITS

| Gaskets                              | Part numbers |
|--------------------------------------|--------------|
| U Series Firebox Glass Gasket (20ft) | 50-3896      |
| U Series Silicone Glass Gasket (4ft) | 50-3897      |
| U50 & U70 Relief Gasket (2 pcs)      | 50-3921      |

| Wire Harnesses                 | Part Numbers |
|--------------------------------|--------------|
| ProFlame 2 IFC Wire Harness    | 50-3030      |
| U Series On/Off Switch Harness | 50-3893      |
| U50/U70 Fan Wire Harness       | 50-3927      |

## Troubleshooting:

| Problem  | Cause  | Solution  | Check   |
|--|--|---|---|
| Burner doesn't turn on                                     | IFC ON/OFF circuit is OPEN                   | Ensure ON/OFF circuit is complete (check with multimeter)   | Check the ON/OFF switch, confirm "-" symbol is pressed down<br>Check for continuity across burner switch<br>Check for continuity across timing relay terminal A and B (see "Safety Circuit System")   |
|  | Remote signal not being received             | Ensure IFC is receiving remote commands (beeping)<br>**Remote commands may need to be repeated  | Re-sync remote<br>Weak or dead remote batteries<br>Check receiver antenna is in correct location (see "Fireplace Control Panel")<br>Check for red blinking light on IFC (see "IFC locked out" below)  |
|  | No call for heat                             | Ensure heat has been called for   | Check thermostat setting is below set point<br>Check third party fireplace control  |
|  | Unresponsive IFC                             | Ensure IFC is working correctly<br>*audible beeps confirms IFC is getting power   | Check circuit breaker<br>Check for 120VAC at IFC<br>Check IFC fuse<br>Check for red blinking light on IFC (see "IFC error" troubleshooting section)   |
|  | Problem with pilot                           | Ensure pilot flame is operational   | See "Pilot flame not lighting," below   |
| Pilot not attempting to spark                              | No call for heat                             | Ensure heat has been called for   | Check thermostat setting is below set point<br>Check third party fireplace control  |
|  | Locked out IFC                               | Reset IFC   | See "Unresponsive fireplace" below  |
|  | Spark signal interrupted                     | Ensure complete sparkler circuit  | Check electrode rod not shorting out on burner platform - adjust rod only if necessary<br>Check electrode wire not shorting out (especially at aluminum pilot line)<br>Check orange electrode wire has firm connection at IFC<br>Check pilot electrode orientation to pilot hood - should be no more than 1/4" away   |
| <i>Natural vent</i>  | Power vent (PV) circuit is OPEN              | Ensure PV circuit is closed (check with multimeter)   | Check the PV switch, confirm "-" symbol is pressed down (see "Fireplace Control Panel")<br>Ensure the IFC PV jumper hasn't come loose inside the IFC (orange wires)   |
|  | Power vent (PV) circuit is CLOSED            | Ensure PV system is working   | See "Fireplace unresponsive" below  |
| <i>Power vent</i>  | Power vent (PV) circuit is OPEN              | Ensure PV circuit is closed (check with multimeter)   | Check the PV switch, confirm "-" symbol is pressed down (see "Fireplace Control Panel")<br>Ensure the IFC PV jumper hasn't come loose inside the IFC (orange wires)   |
|  | Power vent (PV) circuit is CLOSED            | Ensure PV system is working   | See "Fireplace unresponsive" below  |
| Pilot flame not lighting or weak flame (has spark at hood) | Air in pilot gas line                        | Purge pilot gas line  | May take a few ignition cycles for gas to self-purge (may need to hard reset IFC after cycles)  |
|  | Not enough gas pressure                      | Ensure gas is reaching pilot  | Check gas inlet supply and pressure (see "Gas Connections")<br>Check for complete wiring connections at valve (look for faux connections)<br>Check pilot is set-up for correct fuel-type<br>Check for pilot flame obstructions (typically burner media)<br>Check for debris in pilot line at pilot head (typically propane units)<br>Check pilot flame adjustment screw on valve<br>Check for pilot line leak - do you smell gas?   |
|  |  |   |   |
| Pilot flame not staying lit                                | 7 continuous days with no burner operation   | Re-start fireplace using remote   | This is normal  |
|  | Problem with flame sensor circuit            | Ensure healthy flame rectification  | Ensure sensor hook is glowing bright red<br>Check for healthy pilot; ensure sensor hook is fully engulfed in flame<br>Check sensor hook is not touching pilot hood<br>Check white sensor wire has firm connection with IFC<br>Check sensor hook for corrosion, film, or debris<br>Check pilot for healthy ground (check pilot hood continuity)  |
|  | Exhaust Restrictor Setting                   | Ensure correct exhaust restriction setting  | See "Venting Configuration"   |
| Flame dropping out (visual flame problems)                 | Improper fireplace settings                  | Ensure proper fireplace settings  | Check exhaust restrictor setting; see "Venting Configuration"<br>Check venting configuration is approved<br>Check for venting obstructions (including at termination cap)<br>Check primary air setting; see "Primary Air Adjustment"  |
|  | Weak or erratic pilot flame                  | Ensure pilot flame is healthy   | Check flame sensor circuit; see "Pilot flame not staying lit"   |
|  | Environmental conditions (windy)             | Fireplace adjustment may be necessary   | Check for approved high-wind termination cap<br>Check for proper fireplace settings (see above)<br>Adjust exhaust restrictor only if necessary  |
| Flame dropping out (no visual flame problems)              | Environmental conditions (extreme cold)      | Use "Continuous Pilot" mode (CPI)   | This will help the fireplace establish draft when freshly turned on   |
|  | Problem with safety circuit                  | Ensure safety system is functioning correctly   | Review safety system; see "Safety Circuit System"<br>Check monitored fan(s) are functioning at a decent speed<br>Check for complete sail switch operation<br>Check for continuity across sail switch terminals A and B (see "Safety Circuit System")<br>Check monitored fan(s) are functioning at a decent speed<br>Check for complete sail switch operation<br>Check for continuity across sail switch terminals A and B (see "Safety Circuit System")   |
| Flame cycling on/off (15-20 min)                           | Not enough gas supply                        | Ensure proper gas flow and pressure<br>Ensure pilot is operational  | Check fuel supply and gas test ports (see "Gas Connections")<br>See "Pilot flame not staying lit"   |
|  | No sail switch signal                        | Ensure proper sail switch operation   | Ensure all sail switches are activating when cooling fans turn on (approx 15-20min)<br>There should be continuity across sail switch terminals when fan operating<br>Ensure cooling fan is properly mounted on isolators; fan must be level<br>Check for binding sail switch counterweight<br>Ensure sail switch body is secured in proper position   |
| Flame cycling on/off (irritating clicking)                 | Dead or weak fan (monitored)                 | Ensure monitored fan(s) are running at a decent speed<br><br>Ensure all fans are seeing at least 100VAC                                       | Check for blown fan fuse<br>Check for dust, debris, or pet hair at fan axles<br>There should be continuity across fan terminals (check when off)<br>If fan is weak but free of debris then replace<br>If all fans are weak, check for voltage output across fan rheostat  |
|  | Sail switch(s) fluttering                    | Ensure proper sail switch operation   | Check for weak fan (monitored) - See above<br>Ensure sail paddle is in direct air flow<br>Ensure cooling fan is properly mounted on isolators; fan must be level<br>Ensure sail switch body is secured in proper position   |
| Flame lifting  | Too much primary air                         | Decrease primary air by closing air shutter (venturi)   | See "Adjusting Primary Air Setting"   |
|  | Exhaust restrictor setting                   | Improper exhaust restrictor setting   | See "Venting Configuration"; adjust only if necessary   |
|  | Problem with venting system                  | Ensure venting system is properly set-up  | Check for approved high-wind termination cap<br>Check venting configuration is approved<br>Check for leaks in venting system  |
| Flame weaving, bending or uneven (some is normal)          | Input rate too high                          | Ensure correct gas orifice size and manifold pressure   | See rating label for details  |
|  | Trouble establishing draft (weather related) | Use "Continuous Pilot" mode (CPI)   | This will help the fireplace establish draft when freshly turned on   |
| Flame weaving, bending or uneven (some is normal)          | Poor firebox seal                            | Ensure complete seal at glass silicone strips<br><br>Ensure firebox sealed  | Massage silicone strips to fill in sliver gaps and voids<br>Ensure all hand knobs are tight - ensure upper clamps are in correct slot location<br>Check for dirt or particles sticking to strips; use denatured alcohol to clean<br>Side glass may need adjustment (see "Inner Glass Installation")<br>Ensure top and bottom glass corners are sealed with liquid silicone (not included)<br>Check for damaged fiberglass perimeter tape<br>Check for damaged or misalignment of pressure relief door gaskets |
|  | Uneven secondary air distribution            | Ensure burner platform is secured<br><br>Ensure even air slot height around burner<br>(U70 NG models) Back and forth warping of diffuser mesh | Check for missing or stripped screws<br>Check for warping in burner platform (when installed)<br>Check for unsettled burner platform (sitting on a screw, liner clip, or weld build up)<br>This is normal   |

|                                     |   |   |   |   |
|-------------------------------------|---|---|---|---|
|                                     | Incorrect media placement   | Ensure secondary air slots are cleared  | Check for piled up burner media covering air slots (vermiculite/glass media)<br>Check for logs/rocks covering air slots<br>Check for excessive burner media (no more than 1 layer thick)<br>Check for foreign burner media  |   |
|                                     | Leaking burner  | Ensure burner is sealed   | Visually inspect burner for leaks; replace if necessary - DO NOT TEST WITH OPEN FLAME   |   |
| Blue flames (excessive)             | Fireplace is warming up   | Flames will yellow as fireplace heats up  | This is normal  |   |
|                                     | Too much primary air  | Decrease primary air by closing air shutter (venturi)   | See "Adjusting Primary Air Setting"<br>Poor air shutter seal on venturi box   |   |
|                                     | Exhaust restrictor setting  | Improper exhaust restrictor setting   | See "Venting Configuration"; adjust only if necessary   |   |
| Rich flames (excessive)             | Not enough primary air  | Increase primary air by opening air shutter (venturi)<br>(NG) Remove venturi box covers for even more primary air   | See "Adjusting Primary Air Setting"<br>Check that the venturi box covers are removed (LP)   |   |
|                                     | Improper exhaust restrictor setting   | Adjust exhaust restrictor setting   | See "Venting Configuration"; adjust only if necessary   |   |
|                                     | Problem with venting system   | Ensure venting system is properly set-up  | Check for approved high-wind termination cap<br>Check venting configuration is approved<br>Check venting system for leaks   |   |
|                                     | Incorrect media placement   | Adjust burner media   | Check log positioning<br>Check burner media quantity (should be one layer deep)<br>Check for obstructed secondary air slots around burner   |   |
|                                     | Incorrect gas input rate  | Ensure gas input spec's match rating label  | Check gas inlet pressure<br>Check gas manifold pressure (with unit running)<br>Check gas orifice matches rating label for correct fuel type   |   |
| Glass fogs on start-up              | Condensation is formed on start up  | Use "Continuous Pilot" mode (CPI)   | This is normal, more so in damper climates  |   |
| Glass gets hazy over time           | Additives in gas accumulates on glass                                       | Use "Continuous Pilot" mode (CPI)   | This will reduce the build-up rate; clean as necessary  |   |
| Fireplace gets excessively hot      | Temp sensor is faulty   | Ensure temp sensor is working   | Sensor terminals should be opened when switch is cool (under 100F)<br>Sensor terminals should be closed when switch is cool (over 120F)   |   |
|                                     | Timing relay is faulty  | Ensure timing relay is working  | There should be no power at relay when temp sensor is open (cool)<br>There should be continuity across purple wires only when temp sensor is closed (5s delay)<br>There should be 120VAC at timing relay only when temp sensor is closed  |   |
|                                     | Dead or weak fan(s)   | Ensure all fans are running at a decent speed   | Check for blown fan fuse<br>Check for dust, debris, or pet hair at fan axles<br>There should be continuity across fan terminals (disconnect from circuit)<br>If fan is weak but free of debris then replace<br>If all fans are weak, check for voltage output across fan rheostat                             |   |
|                                     | Sticking sail switch(s)<br>(coupled with weak/dead fan)                     | Ensure proper sail switch operation   | There shouldn't be continuity across sail switch without fan operating<br>Check for binding sail switch counterweight   |   |
|                                     | Chase construction obstruction  | Ensure all installation spec's are met<br>Ensure no air flow obstructions<br>Ensure all appropriate heat shields are installed  | Ensure air intake and heat release areas are at or above minimum spec<br>Check for foreign objects blocking air intake and heat release (even a relaxing pet)<br>Check installation section for further details   |   |
|                                     | Material encroaching on minimum clearances                                  | Ensure all installation spec's are met  | Check installation section for further details<br>Ensure there're no foreign objects on or above the unit within the chase  |   |
|                                     | Problem with venting system   | Ensure venting system is properly set-up  | Check venting configuration is approved<br>Check for venting obstructions   |   |
|                                     | Exhaust restrictor setting  | Exhaust restrictor setting too high   | Reduce exhaust restriction  |   |
|                                     | Incorrect gas input rate  | Ensure gas input spec's match rating label  | Check gas inlet pressure<br>Check gas manifold pressure (with unit running)<br>Check gas orifice matches rating label for correct fuel type   |   |
|                                     | Top light not working   | Burnt out light bulb  | Replace light bulb assembly (50-3516)   | Visually inspect bulb for signs of damage, confirm continuity with multimeter |
|                                     |   | Blown top light fuse  | Replace top light fuse (50-2076)  | Visually inspect bulb for signs of damage, confirm continuity with multimeter |
| Faulty wiring                       |   | Ensure complete top light circuit   | Check for wire chaffing inside light box<br>Check top light circuit with multimeter   |   |
| LEDs not working (if equipped)      | Faulty LED wiring   | Ensure all LED wiring connections are secured<br><br><i>If red operating light is on LED controller</i>   | Use wiring diagram for details<br>Ensure "AUX" feature is activated on remote transmitter<br>LED controller input wires may have come disconnected (red and black wires)<br>Wiring at LED strip may have come disconnected (access from under burner)<br>Check for "AUX" circuit operation using a multimeter |   |
|                                     | Faulty LED components   | Ensure LED controller is working<br>Ensure LED driver is working<br>*LED driver is working if LED controller operating light is on<br>(Discolouring is OK) Ensure LED strip is not visually damaged | Check for red operating light on LED controller<br>Check for 12-24VDC at LED controller input<br>Check for 120VAC at LED driver input (blue and brown wires)<br>Wiring at LED strip may have come disconnected (access from under burner)   |   |
| LED dead section                    | Damaged LED in section  | Replace LED strip (access from under burner)  | LEDs sections are 8" long; one damaged LED will kill the whole section  |   |
| LEDs work but not responding        | No command signal to LED controller   | Ensure commanding device is linked to LED controller<br>Reset LED controller with supplied pin (or paper clip)  | Check that mobile device (or third party system) is pair to LED controller<br>Check for red operating light on LED controller   |   |
| IFC locked out (flashing red light) | Flame sensor signal lost during burner operation                            | Ensure healthy burner operation   | See "Flame dropping out."   |   |
|                                     | Pilot ignition sequence timed out   | Ensure healthy pilot operation  | See "Pilot not lighting."   |   |
|                                     | Fireplace lost gas supply   | Ensure proper gas flow and pressure   | Check gas inlet supply and pressure   |   |
|                                     | Problem with safety circuit system<br>(flame shuts off after 10-20 minutes) | Ensure safety system is functioning correctly   | Check monitored fan(s) are functioning at a decent speed<br>Check for complete sail switch operation (U50/U70 models have 2)<br>Check for continuity across sail switch terminals (see "Safety Circuit System")<br>Check for correct timing relay switch operation (see "Safety Circuit System")              |   |
|                                     | IFC confused  | Soft reset IFC<br>Hard reset IFC  | Press reset button on fireplace switch panel and re-sync remote (tool may be required)<br>Cut power to IFC (could use circuit breaker) and reconnect  |   |
| Fireplace unresponsive              | No power to fireplace   | Ensure the fireplace is seeing 120VAC   | Check circuit breaker<br>Do any fireplace features work? If so, fireplace has power<br>Check for 120VAC at the IFC  |   |
|                                     | Blown IFC fuse  | Replace IFC fuse with exact replacement   | Check for bare electrical connections<br>Check for electrical short in top light box<br>Was there a recent power surge?   |   |
|                                     | IFC locked out  | Reset IFC   | See "IFC locked out" for possible causes  |   |
|                                     | Natural vent<br>Power vent mode activated                                   | PV switch in incorrect position<br>PV jumper came lose inside IFC   | Check the position of PV switch - the "-" should be down if operating with natural vent<br>Ensure the IFC PV jumper hasn't come lose inside the IFC (orange wires)  |   |
|                                     | Power vent<br>Natural vent mode activated                                   | PV switch in incorrect position   | Check the position of PV switch - the "o" should be down if operating with power vent   |   |
|                                     | IFC not receiving vacuum switch signal                                      | Ensure vacuum switch signal reaching IFC  | Ensure secure wiring interceptor connections at IFC (yellow wires)<br>Check for continuity across vacuum signal while in start-up mode<br>Check for PV fan operation during start-up mode (can you hear it?)<br>If the sparkler is activating then PV start-up mode is functioning, problem lies elsewhere    |   |

## Wiring Diagram:

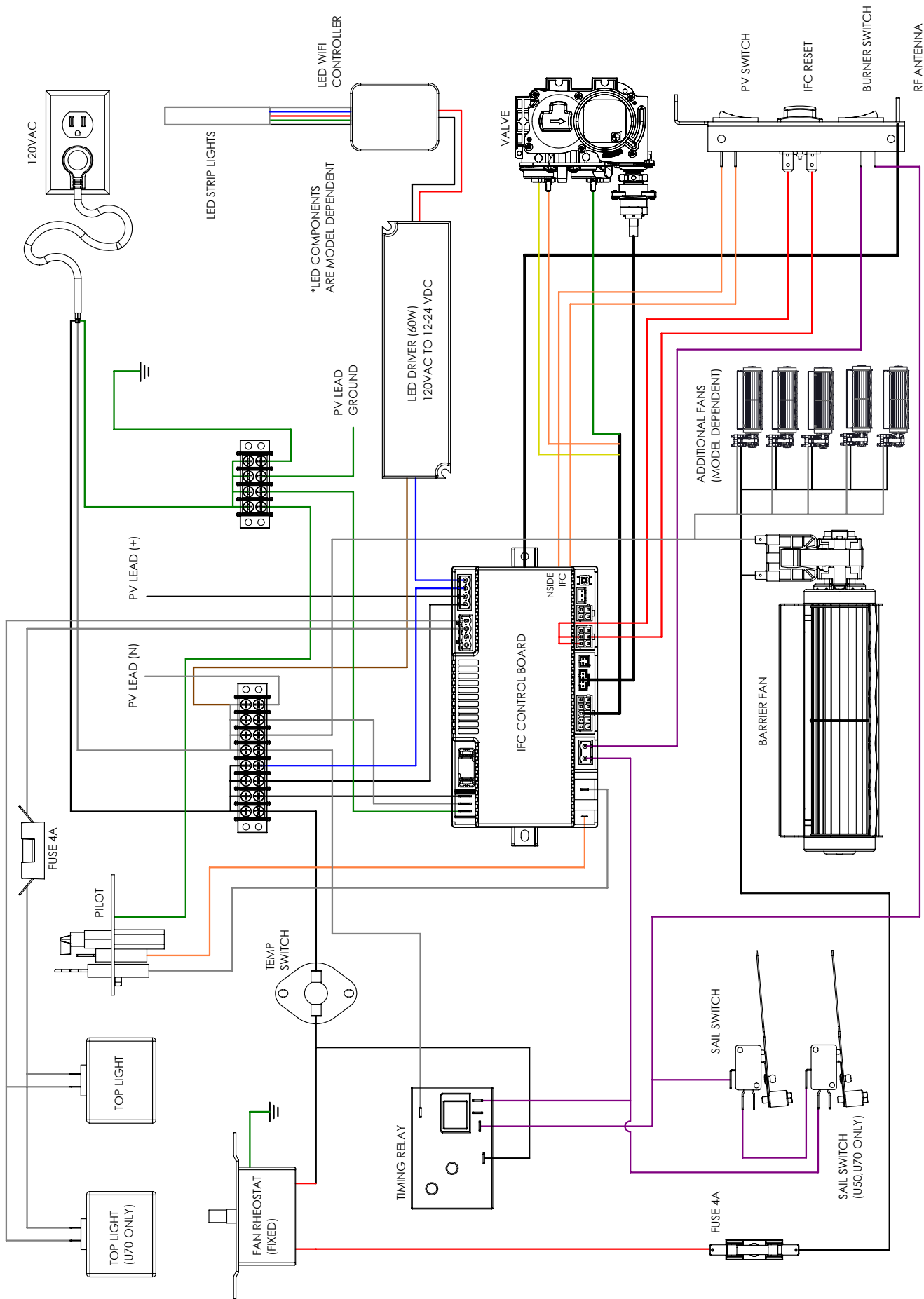

**Please fill in and retain this information card for your future reference.**

Go to [www.urbanafireplaces.com/warranty](http://www.urbanafireplaces.com/warranty) to fill in your warranty registration card.

**NAME OF DEALER:**

\_\_\_\_\_

**ADDRESS:**

\_\_\_\_\_

\_\_\_\_\_

\_\_\_\_\_

**PHONE:** \_\_\_\_\_

**NAME OF INSTALLER:**

\_\_\_\_\_

**ADDRESS:**

\_\_\_\_\_

\_\_\_\_\_

\_\_\_\_\_

**PHONE:** \_\_\_\_\_

**MODEL:** \_\_\_\_\_

**SERIAL NUMBER:** \_\_\_\_\_

**DATE OF PURCHASE:** \_\_\_\_\_ (dd/mm/yyyy)

**DATE OF INSTALLATION:** \_\_\_\_\_ (dd/mm/yyyy)

NATURAL GAS (NAT)       PROPANE(LPG)

**INLET GAS PRESSURE:** \_\_\_\_\_ in wc

**MAIN BURNER ORIFICE:** \_\_\_\_\_ # DMS

**PILOT ORIFICE #** \_\_\_\_\_ **OR** \_\_\_\_\_ in diam.

**INSTALLER'S SIGNATURE:**

\_\_\_\_\_

## URBANA LUXURY FIREPLACES

## WARRANTY INFORMATION

Sherwood Industries Ltd. ("Sherwood") hereby warrants, subject to the terms and conditions herein set forth, this product against defects in material and workmanship during the specified warranty period starting from the date of original purchase at retail. In the event of a defect of material or workmanship during the specified warranty period, Sherwood reserves the right to make repairs or to assess the replacement of a defective product at Sherwood's factory. The shipping costs are to be paid by the consumer. All warranties by Sherwood are set forth herein and no claim shall be made against Sherwood on any oral warranty or representation.

### Conditions

- ☞ A completed warranty registration must be submitted to Sherwood within 90 days of original purchase via the online warranty registration page or via the mail-in warranty registration card provided. Have the installer fill in the installation data sheet in the back of the manual for warranty and future reference.
- ☞ This warranty applies only to the original owner in the original location from date of install.
- ☞ The unit must have been properly installed by a qualified technician or installer, and must meet all local and national building code requirements.
- ☞ The warranty does not cover removal and re-installation costs.
- ☞ Sherwood Industries Ltd. reserves the right to make changes without notice.
- ☞ Sherwood Industries Ltd. and its employees or representatives will not assume any damages, either directly or indirectly caused by improper usage, operation, installation, servicing or maintenance of this appliance.
- ☞ A proof of original purchase must be provided by you or the dealer including serial number.

### Exclusions

An expanded list of exclusions is available at [www.urbanafireplaces.com/warranty.html](http://www.urbanafireplaces.com/warranty.html)

This warranty does not cover:

- ☞ Damage as a result of improper usage or abuse.
- ☞ Damage caused from over-firing due to incorrect setup or tampering.
- ☞ Damage caused by incorrect installation.

### To the Dealer

- ☞ Provide name, address and telephone number of purchaser and date of purchase.
- ☞ Provide date of purchase. Name of installer and dealer. Serial number of the appliance. Nature of complaint, defects or malfunction, description and part # of any parts replaced.
- ☞ Pictures or return of damaged or defective product may be required.

### To the Distributor

- ☞ Sign and verify that work and information are correct.

### Sherwood Industries Ltd.

6782 Oldfield Road, Victoria, BC . Canada V8M 2A3  
 Online warranty registration: [www.urbanafireplaces.com/warranty/](http://www.urbanafireplaces.com/warranty/)

| Category   | One Year | Two Year | Limited Lifetime (7yr) |
|--|----------|----------|------------------------|
| Parts <sup>1</sup> (unit serial number required) |          | ✓        |                        |
| Firebox Liner Panels <sup>2</sup>                |          | ✓        |                        |
| Firebox  |          |          | ✓                      |
| Burner   |          |          | ✓                      |
| Ceramic Logs <sup>3</sup>                        |          |          | ✓                      |
| Ceramic Glass <sup>4</sup>                       | ✓        |          |                        |
| Door Assembly                                    |          |          | ✓                      |
| Exterior Panels (excluding finish) <sup>5</sup>  |          |          | Up to 5 years          |
| Electrical Components                            |          | ✓        |                        |
| Labour   | ✓        |          |                        |

<sup>1</sup> Whereas warranty has expired, replacement parts will be warranted for 90 days from part purchase date. Labour not included. Unit serial # required.

<sup>2</sup> Excluding damage to the finish caused by improper setup of the appliance, or color changes.

<sup>3</sup> Log set and panels excludes wear and tear or breakage caused by cleaning or service.

<sup>4</sup> Glass is covered for thermal breakage. Photos of box, inside of door, and unit serial # must be supplied for breakage due to shipping.

<sup>5</sup> Exterior Surface finishing covers plating, enamel or paint and excludes colour changes, chipping, and fingerprints. Travel costs not included.

MANUFACTURED BY:  
SHERWOOD INDUSTRIES LTD.  
6782 OLDFIELD RD. SAANICHTON, BC, CANADA V8M 2A3  
[www.urbanafireplaces.com](http://www.urbanafireplaces.com)  
Summer 2020  
C-15883