

Jøtul F 3 CB

Jøtul F 3 CB

Installation and Operating Instructions for the USA and Canada	2
Exploded view	20



Kindly save these instructions for future reference.

USA/Canada

Table of Contents

Standards and Safety Notices	3
1.0 Installations	4
2.0 Chimney Requirements	
Masonry Chimney	6
Prefabricated Chimney	7
Chimney height	7
Wall pass-throughs.....	7
3.0 Connecting to the Chimney	
Masonry chimneys.....	8
Hearthmount/Fireplaces.....	8
Prefabricated Chimney	9
4.0 Clearances	
Floor requirements	10
Wall shields.....	11
Stove Clearances.....	12
Alcove Installations.....	13
5.0 Operation	
Controls.....	14
Breaking in your new Stove	14
Starting/Maintaining	15
Formation of Creosote	15
6.0 Maintenance	
Ash Removal	16
Glass Care.....	16
7.0 General Maintenance	
Gaskets.....	17
8.0 Accessories	
Firescreen	18
Floor Bracket Kit.....	18
Stove -Top Thermometer	18
9.0 Appendix A	
Alternate Floor Protecion	19
Parts Diagram	20
Part list.....	21

Save these instructions and make them available to anyone using or servicing the stove.

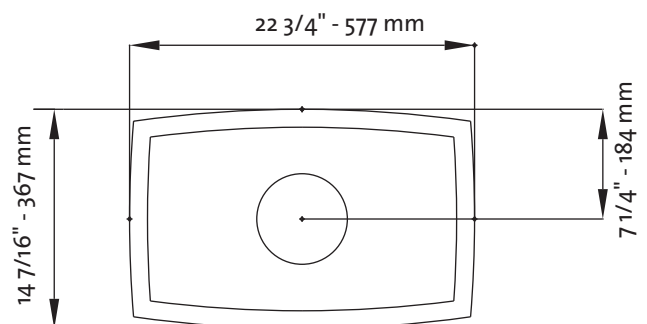
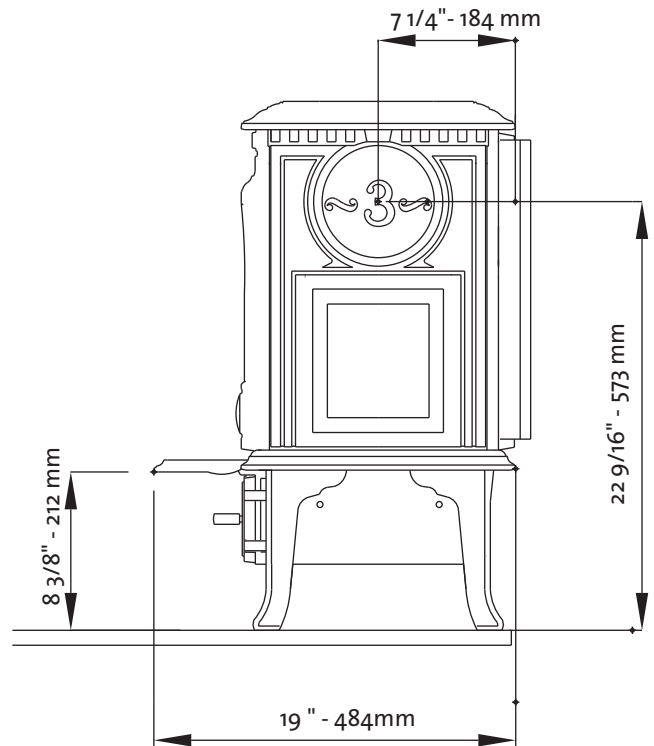
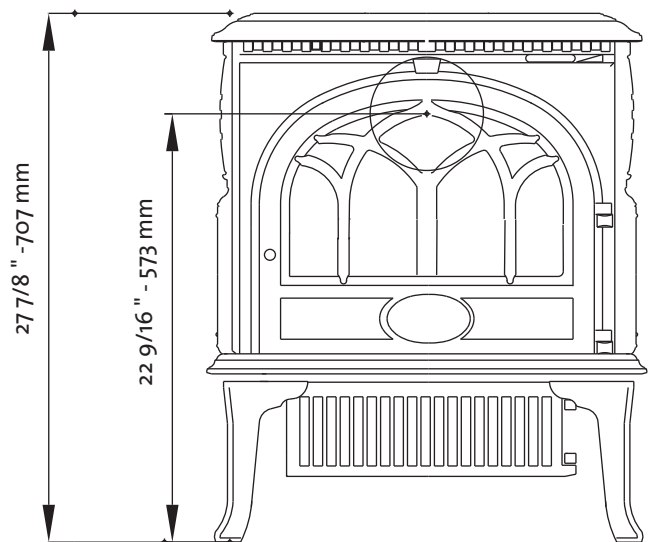

Installation and Operation Instructions for USA/Canada

Installation et fonctionnement pour Canada

Safety notice: If this solid fuel room heater is not properly installed, a house fire may result. For your safety, follow the installation directions. Contact local building or fire officials about restrictions and installation inspection requirements in your area. Save these instructions for future reference.

Avis de sécurité: Une installation non appropriée de ce poêle de chauffage risque de provoquer un incendie. Assurez votre sécurité en respectant les directives d'installation suivantes. Consultez les autorités locales du bâtiment ou de la prévention des incendies au sujet des restrictions et exigences relatives aux inspections d'installations dans votre région.

Tested and listed by ITS, Intertek Testing Services, Middleton, Wisconsin.
Tested to U.S. Standards: ANSI/UL 737 and ANSI/UL 1482
Canadian Standards: CAN/ULC-S627-M93 and CAN/ULC-S628-M93



Standards

The Jøtul F 3 CB woodstove has been tested and listed to:
 U.S. Standards: ANSI/UL 737 and ANSI/UL 1482
 Canada: CAN/ULC-S627-M93 and CAN/ULC-S628-M93

Tests performed by:
 ITS, Intertek Testing Services, Middleton, WI

Manufactured by:
 Jøtul AS., P.O. Box 1411, Fredrikstad, Norway

Distributed by:
 Jøtul North America Inc, 55 Hutcherson Drive,
 Gorham, Maine 04038, USA

This heater meets the U.S. Environment Protection Agency's Emissions limits for wood heaters manufactured and sold after July 1, 1990.

Under specific test conditions, this heater has shown heat output at rates ranging from 11,500 to 43,500 BTU's per hour.

The Jøtul F 3 CB woodstove is only listed to burn wood. Do not burn any other fuels.

Read this entire manual before you install and use your new room heater.

Save these instructions and make them available to anyone using or servicing the stove.

Check Building Codes

When installing, operating and maintaining your Jøtul F 3 CB woodstove, follow the guidelines presented in these instructions, and make them available to anyone using or servicing the stove.

Your city, town, county or province may require a building permit to install a solid fuel burning appliance.

In the U.S., the National Fire Protection Association's Code, NFPA 211, *Standards for Chimneys, Fireplaces, Vents and Solid Fuel Burning Appliances*, or similar regulations, may apply to the installation of a solid fuel burning appliance in your area.

In Canada, the guideline is established by the CSA Standard, CAN/CSA-B365-M93, *Installation Code for Solid-Fuel-Burning Appliances and Equipment*.

Always consult your local building inspector or authority having jurisdiction to determine what regulations apply in your area.



We suggest that our woodburning hearth products be installed and serviced by professionals who are certified in the U.S. by the National Fireplace Institute® (NFI) as NFI Woodburning Specialists or who are certified in Canada by Wood Energy Technical Training (WETT).



USA/Canada

Notices

- Be sure to read this entire manual before you install or use your new Jøtul F 3 CB.
- If this room heater is not properly installed, a house fire may result. To reduce the risk of fire, follow the installation instructions. Failure to follow these instructions may result in property damage, bodily injury, or even death.
- Jøtul recommends that you have your new Jøtul F 3 installed by a professional installer of solid fuel burning appliances.
- Extremely hot while in operation! Keep children, clothing and furniture away. Contact may cause skin burns.
- Avoid creating a low pressure condition in the room where the stove is operating. Be aware that operation of an exhaust fan or clothes dryer can create a low pressure area and consequently promote flow reversal through the stove and chimney system. The chimney and building, however, always work together as a system - provision of outside air, directly or indirectly to an atmospherically vented appliance will not guarantee proper chimney performance. Consult your local Jøtul authorized dealer regarding specific installation/performance issues.
- Do not use chemicals or fluids to start the fire. Some fuels will, during combustion, separate carbon monoxide and generate it in the burn chamber. Carbon monoxide is toxic, so please follow the guidelines in this manual for proper operation of your Jøtul F 3.
- If you for some reason experience smoke “roll-out” from the stove, it may activate smoke detectors if installed in the house.

Do not connect this stove to any air distribution duct or system.

1.0 Installation

If this solid fuel room heater is not properly installed a house fire may result. For your safety, follow the installation directions. Contact the local building or fire officials about restrictions and installation inspection requirements in your area.

–
NOTE:

Your local officials have final authority in determining if a proposed installation is acceptable. Any requirement that is not specifically addressed in this manual defaults to NFPA 211, and local codes in the U.S. or in Canada, CAN/CSA-B365-M and local codes.

Installing the Venting

The Jøtul F 3 can be vented from the top, the rear or from either the right or left side. Follow the instructions below for the desired venting location.

Top-exit Venting

When top exit venting is desired, use a 3mm allen wrench to remove the two set screws that secure the top casting to the sides of the stove and lift off the top casting. Lay the top casting upside-down on a flat surface. Remove the 10mm bolt from the cross bar and remove the smoke outlet cover. See figure 1.

NOTE: Ivory and Majolica toves are built for rear-exit flue connection - the rear outlet is left open. THE SMOKE OUTLET COVER PLATE MUST BE REINSTALLED OVER THE REAR OPENING BEFORE REPLACING THE TOP PLATE.

Secure the top plate to the stove body by tightening the set screws previously loosened.

Rear-exit Venting

When rear exit venting is desired it will be necessary to “knock-out” the vent hole from the rear casting on Matte Black and Blue Black stoves. Ivory and Brown Majolica enamel stoves are built with the rear outlet open. Remove the top casting of the stove by removing the two 3mm set screws that secure the top to the sides. The set screws are located on the outside of the stove on the top of each side panel. Use a 10mm wrench to remove the double rear heatshields from the back of the stove. Remove the front door to avoid damage to the glass. **NOTE:** Loss of the hinge washer will result in improper door alignment when reinstalling the door.

Fig. 1

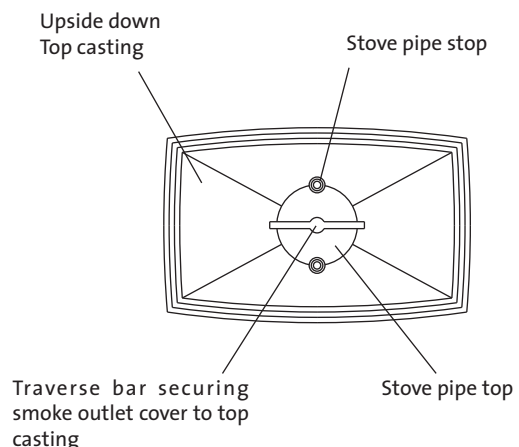

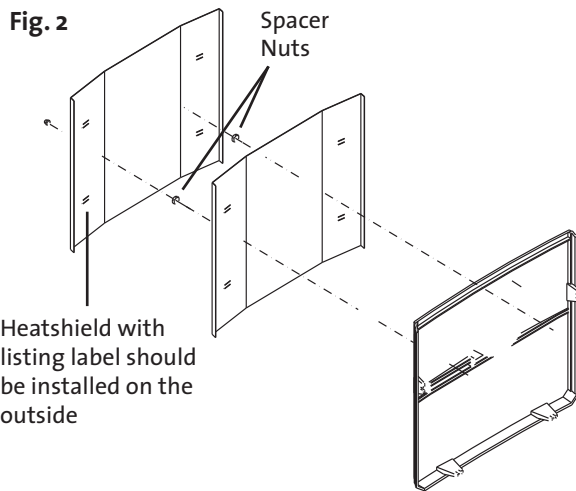

Use a hammer to strike the center of the 6" "knock-out" disc from the outside of the stove. The "knock-out" disc will break into four wedges and may need to be tapped out. Touch up any remaining sharp edges with a file or hand grinder.

Reinstall the top casting and front door with hinge washer. Replace the rear heatshields and shield spacer nuts. Remove the metal cover plates from the heatshields and reinstall. **Reminder:** Reinstall the small nuts used as spacers between the two heatshields. See **fig 2**.

Side-exit Venting

If venting through the side is desired it will be necessary to remove the top casting. Using a 3mm allen wrench remove the two set screws that secure to the top to the side panels. Remove the front door to avoid damage to the glass. **Reminder:** Loss of the door washer will result in improper door alignment when reinstalling the door.

Using a claw hammer or a small sledge hammer strike the center of the 6" "knock-out" disc from the inside of the stove. The "knock-out" disc will break into four wedges and may need to be tapped out. Touch up any remaining sharp edges with a file or hand grinder. Reinstall the front door, remembering the washer and the top casting.

Installing the flue collar

Place the self-adhesive gasket (**Fig.3A**) on the underside of the smoke outlet (**Fig. 3B**). Mount the smoke outlet with use of the supplied screws and cross bar (**Fig. 3C**)

Secure the first section of stove pipe to the flue collar using two sheet metal screws.

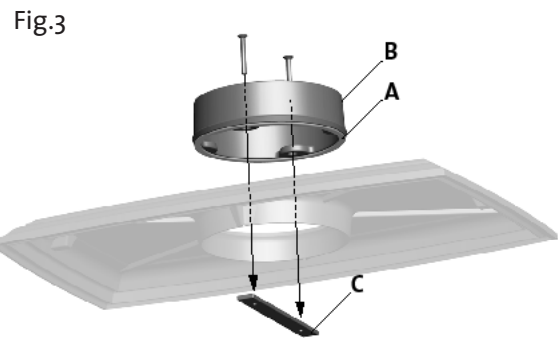

Stove pipe - chimney connector

The chimney connector is a single walled pipe used to connect the stove to the chimney. For use with the Jøtul F3 CB the chimney connector must be 6" in diameter, with a minimum thickness of 24 gauge black steel.

Aluminum and galvanized steel pipe is not acceptable for use with the Jøtul F3 CB. These materials cannot withstand the extreme temperatures of a wood fire and can give off toxic fumes when heated.

Each chimney connector or stove pipe section must be installed to the stove flue collar and to each other with the male (crimped) end toward the stove. See **figure 4**.

Fig. 4

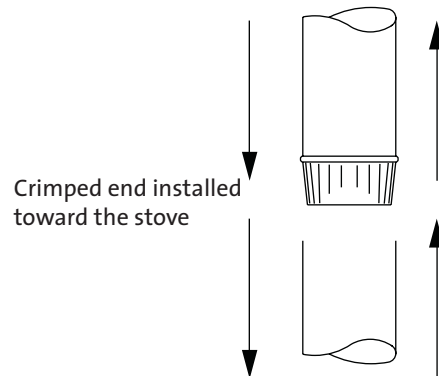

This prevents any amount of condensed or liquid creosote from running down the outside of the pipe or the stove top. All joints must be secured with three sheet metal screws to ensure that the sections do not separate.

For the best performance the chimney connector should be as short and direct as possible, with no more than two 90° elbows. The maximum horizontal run is 36" and a recommended total length of stove pipe should not exceed 10 feet. Always slope horizontal runs upward 1/4" per foot toward the chimney.

No part of the chimney connector may pass through an attic or roof space, closet or other concealed space, or through a floor or ceiling. All sections of the chimney connectors must be accessible for cleaning.

USA/Canada

Where passage through a wall or partition of combustible construction is desired, the installation must conform with NFPA 211 or CAN/CSA-B365, and is also addressed in this manual.

Do not connect this unit to a chimney flue servicing another appliance.

Do not use the connector pipe as a chimney.

2.0 Chimney requirements

There are two types of chimneys suitable for the Jøtul F3:

1. A code-approved masonry chimney with a flue liner.
2. A prefabricated chimney complying with the requirements for type HT (2100°F) chimneys per UL 103 or ULC S629.

The chimney size should not be less than the cross-sectional area of the flue collar, and not more than three times greater than the cross-sectional area of the flue collar.

When selecting a chimney type and the location for the chimney, as well as the proximity of surrounding trees or buildings.

As a result, a short masonry chimney on the exterior of a house will give the poorest performance. This is because it can be very difficult to warm the chimney thereby creating inadequate draft. In extremely cold northern areas it may be necessary to reline the chimney or extend its height to help establish draft.

Oppositely, a tall masonry chimney inside the house is easier to keep warm and will perform the best.

The following guidelines give the necessary chimney requirements based on the national code (ANSI-NFPA 211 for the us. And CSA CAN-B365 for Canada). However, many local codes differ from the national code to take into account climate, altitude, or other factors. It is important that you check with your local building officials to find out what codes apply in your area before installing your new Jøtul F3 CB.

CHIMNEY INSPECTION: A Level II (camera) inspection of an existing chimney system must be conducted by a qualified technician as specified by NFPA 211 when verification of the suitability of the chimney for new or changed conditions of service is needed or when a Level I inspection is not sufficient to determine serviceability of the chimney.

Masonry chimneys

When installing the Jøtul F3 into a masonry chimney you must conform to all of the following guidelines:

- The chimney flue size should not be less than the cross sectional area of the stove flue collar.
- The cross-sectional area of the flue of a chimney with no walls exposed to the outside below the roofline shall not be more than three times the cross-sectional area of the stove flue collar.
- The cross-sectional area of the flue of a chimney with one or more walls exposed to the outside below the roofline shall not be more than two times the cross-sectional area of the stove flue collar.
- Larger chimney flues should be relined with a listed or code approved liner.
- The masonry chimney must have a fireclay liner or equivalent, with a minimum thickness of 5/8" and must be installed with refractory mortar. There must be at least 1/2" air space between the flue liner and chimney wall.
- The fireclay flue liner must have a nominal size of 8" x 8", and should not be larger than 8" x 12". If a round fireclay liner is to be used it must have a minimum inside diameter of 6" and not larger than 8" in diameter. If a chimney with larger dimensions is to be used, it should be relined with an appropriate liner that is code approved.
- The masonry wall of the chimney, if brick or modular block, must be a minimum of 4" nominal thickness. A mountain or rubble stone wall must be at least 12" thick.
- A newly-built chimney must conform to local codes and in their absence must recognize national regulations.
- When using an existing chimney, it must be inspected by a professional licensed chimney sweep, fire official, or code officer, to ensure that the chimney is in proper working order.
- No other appliance can be vented into the same flue.
- An airtight clean-out door should be located at the base of the chimney.

Prefabricated chimneys

If a prefabricated metal chimney is to be used it must be a chimney type that is tested and listed for use with solid fuel burning appliances. High temperature (ht) chimney standard UL103 for the U.S. And high temperature standard ULC S-629 for Canada.

The manufacturer's installation instructions must be followed precisely. Always maintain the proper clearance to combustibles as established by the pipe manufacturer. This clearance is usually a minimum of 2", although it may vary by manufacturer or for certain chimney components.

Chimney height

Whether a masonry chimney or prefabricated metal chimney is used it must be the required height above the roof line.

The requirement is:

The chimney must be at least 3 feet higher than the highest point where it passes through the roof and at least 2 feet higher than the highest part of the roof or structure that is within 10 feet of the chimney, measured horizontally. See **figure 6**.

Fig. 6

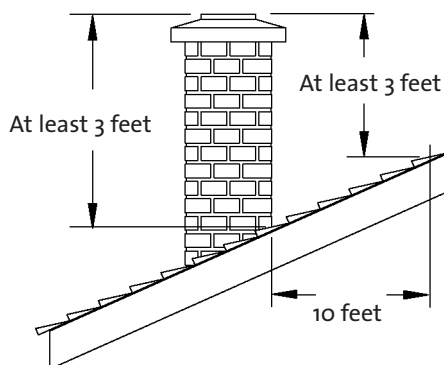

Chimneys shorter than 14 feet may not provide adequate draft. This could result in smoke spilling into the room from the stove when loading the stove, or when the door is open. In addition, inadequate draft can cause back puffing, which is a build up of gases inside the firebox.

Other times, chimney height can create excessive draft which can cause high stove temperatures and short burn times. Excessive drafts can be corrected by installing a butterfly damper. If you suspect you have a draft problem, consult your dealer.

Wall pass-throughs

When your installation unavoidably requires the chimney connector to pass through a combustible wall to reach the chimney, always consult your local building officials, and be sure any materials to be used have been tested and listed for wall pass-throughs.

In the U.S.

The national fire protection association's publication, NFPA 211, standard for chimneys, fireplaces, vents and solid fuel burning appliances permits four methods for passing through a combustible wall. Before proceeding with any method be sure to consult with your local building officials to discuss any local code requirements.

Common method

When passing through a combustible wall to a masonry chimney this method requires the removal of all combustible materials from at least 12" around the chimney connectors proposed location. With a 6" round liner the minimum area required would be 31" x 31" square.

The space is then filled with at least 12" of brick around a fireclay liner. Remember, the liner must be ASTM C35 or equivalent, with a minimum wall thickness of 5/8".

It is important to remember to locate the pass-through at least 18" from the ceiling for proper clearance to combustibles.

It will be necessary to cut wall studs, install headers, and construct a sill frame to maintain the proper dimensions and to support the weight of the brick.

The bricks must be solid brick with a minimum of 3 1/2" thick (4" nominal).

Refractory mortar must be used at the junction of the chimney and the pass-through liner. The pass-through liner must not penetrate the chimney liner beyond the inner surface of the chimney liner. Use extreme care when constructing the hole in the chimney liner, the tiles can shatter easily. See **figure 7**.

Fig. 7

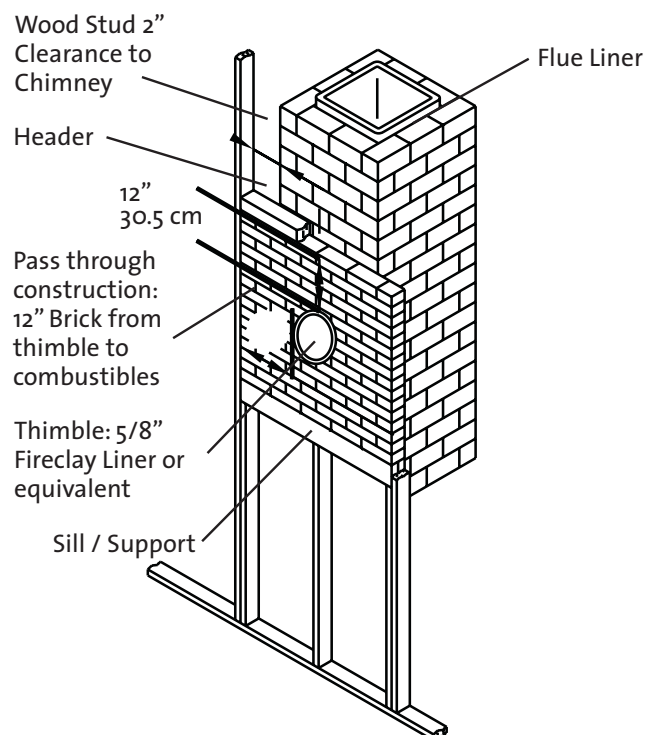

USA/Canada

In Canada

In Canada the standard has been established by the Canadian standard association. The installation must conform to CAN/CSA-B365, installation code for solid fuel burning appliances and equipment. Before proceeding be sure to consult your local building inspector.

Common method

This method requires the removal of all combustible materials from at least 18" (457mm) around the chimney connector's proposed location. With a 6" round liner the minimum area required would be 43" x 43" square.

It is important to remember to locate the pass-through at least 25" from the ceiling to maintain the proper clearance to combustibles.

The space that is cleared of combustible materials must then remain empty. Sheet metal panels can then be used to cover the area. However, when using a panel on both sides of the wall each cover must be installed on noncombustible spacers at least 1" from the wall. If one panel of sheet metal is to be used it may be installed flush to the wall.

See section 5.3.1 and 5.3.2 of CAN/CSA - B365-m91.

Consult your local building inspector, authorized Jøtul Dealer, NFPA 211 in the U.S. or CAN/CSA-B635 in Canada for other approved wall pass-through methods.

3.0 Connecting to the chimney

Masonry chimney

When installing a Jøtul F 3 into a masonry chimney through a "thimble" (the opening through the chimney wall to the flue), the thimble must be lined with ceramic tile or metal and be securely cemented in place.

The chimney connector/stove pipe must slide completely inside the thimble to the inner surface or the flue liner. It may be necessary to make use of a thimble sleeve (a pipe with a slightly smaller diameter than standard stove pipe). This special pipe can be easily installed into a thimble. See **Figure 8**.

Fig. 8

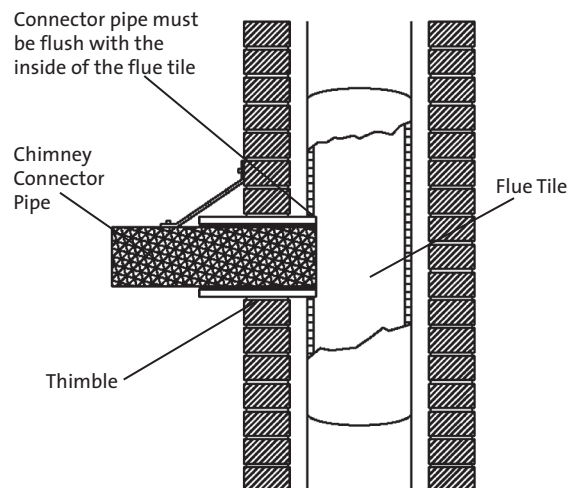

Make sure the connector pipe or thimble sleeve does not protrude into the flue liner, thereby restricting the area the smoke has to flow through. This bottle-neck will have a negative affect on the chimney system.

The chimney connector should be sealed at the thimble with refractory cement and the stove pipe leading to the stove should have a minimum of three screws.

Do not connect this stove to a chimney flue servicing another appliance of any kind.

Hearth-mount into a masonry fireplace

The Jøtul F 3 may be installed into a masonry fireplace provided the opening is a minimum of 28 1/2" high. The short leg package reduces the stove's height by 2 1/4".

When installing the Jøtul F 3 CB into a masonry fireplace, code requires that the fireplace damper plate be removed or securely fixed in the open position. A connector pipe must then extend from the stove's flue exit through the damper area of the fireplace and into the chimney tile liner. See **figure 9**.

Fig. 9

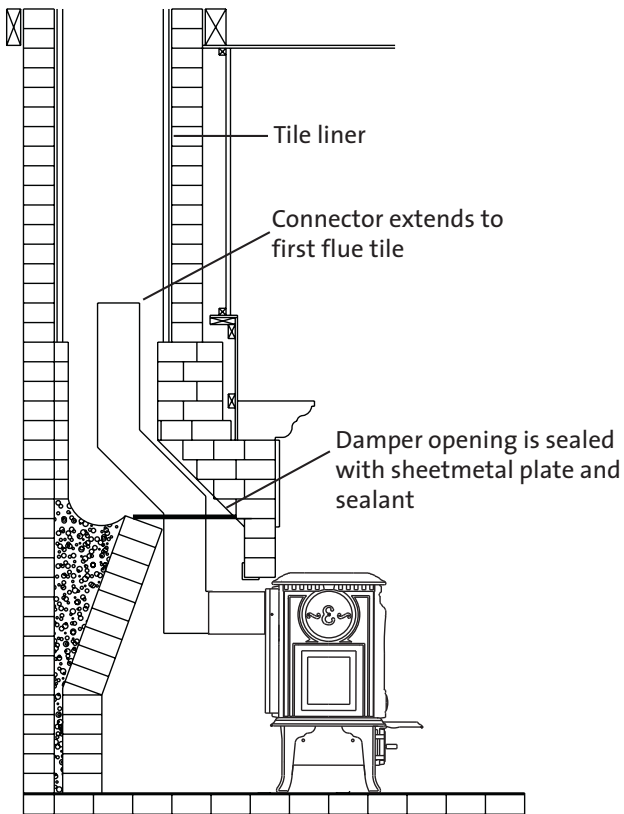

Fig. 10

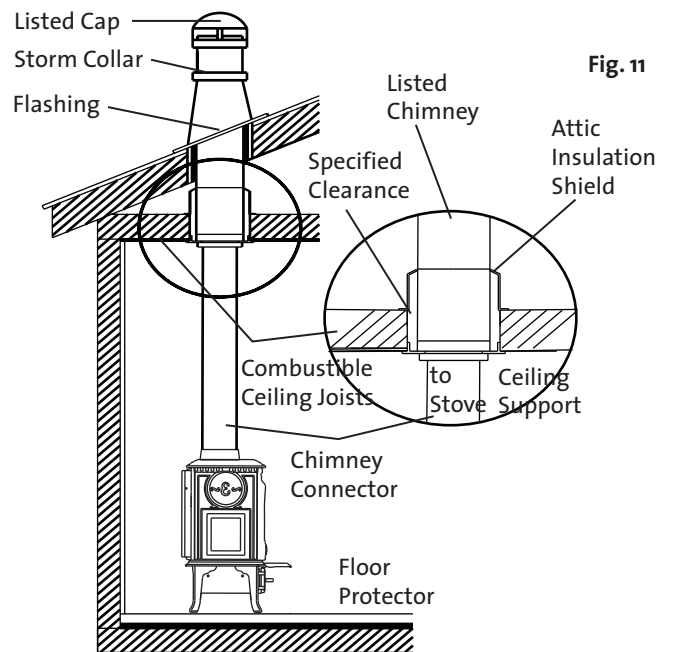

Fig. 11

The inside area of the flue liner must not be less than the area of the stove's flue exit, and cannot be more than three times greater than the cross sectional area of the stove's flue exit.

If the chimney liner is too large to accommodate the stove, an approved relining system must be installed to resize the flue.

A new sheet metal damper block-off plate must be installed around the connector pipe at the damper frame and sealed with the proper sealant (usually high-temp silicone).

Fireplace installation must also observe the proper clearances to surrounding trim and mantels (addressed in clearance section of this manual). In addition, fireplace installations must also adhere to the floor protection guidelines specified in the following section.

Prefabricated chimneys

When installing the Jøtul F 3 to a prefabricated metal chimney always follow the pipe manufacture's instructions and be sure to use the components that are required. This usually includes some type of "smoke pipe adapter" that is secured to the bottom section of the metal chimney and allows the chimney pipe to be secured to it with three sheet metal screws. See **figures 10 and 11**.

4.0 Clearances to combustibles

Floor protection

Floor protection under the Jøtul F 3 CB, must be one of the following:

1. Any non combustible material with an insulative R value of 1.1.
2. Any UL, ULC or WH hearth board or prefabricated non-combustible material.

The bottom heatshield (standard equipment) is required in all installations.

Individual sections of floor protection must be mortared together to prevent sparks from falling through to combustible materials. Any carpeting must be removed from under the floor protection.

In the U.S. and Canada

The Jøtul F 3 CB must be installed on a non-combustible surface extending a minimum of 16" for U.S. (46 cm for Canada) in front of the stove and 8" (20 cm) on the remaining sides of the stove (measured from side and back panels).

This will result in a minimum floor protection of 39 cm D x 39 cm W for U.S., and 104 cm D x 99 cm W for Canada. See figure 12.

In a rear vent installation the floor protection must also extend under the stove pipe a minimum of 2" (5 cm) beyond either side of the pipe.

Fig. 12

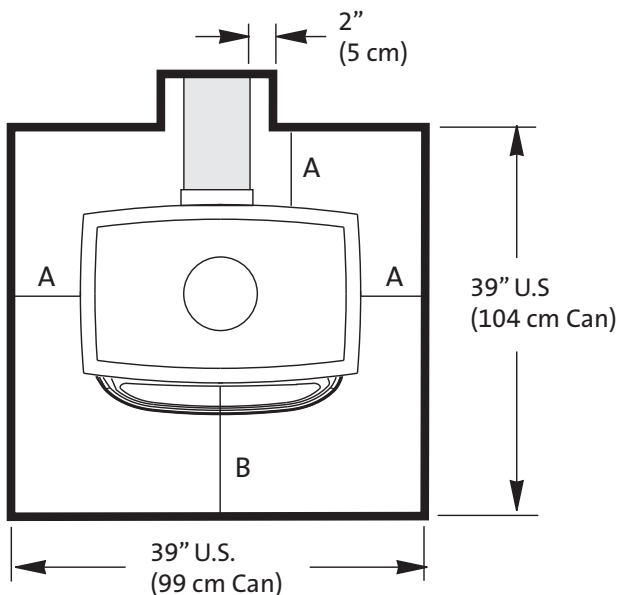

Hearth Protection

A: 8" (20 cm)

B: 16" for U.S. (46 cm for Canada)

Clearances to walls and ceilings

The following clearances have been tested to UL and ULC standards and are the minimum clearances specifically established for the Jøtul F 3 CB. (See next page)

The following charts and diagrams give the required clearances you must maintain when installing the Jøtul F 3 CB near combustible surfaces.

A combustible surface is anything that can burn (i.e. Sheet rock, wall paper, wood, fabrics etc.). These surfaces are not limited to those that are visible and also include materials that are behind non-combustible materials.

If you are not sure of the combustible nature of a material, consult your local fire officials.

Remember: "Fire resistant" materials are considered combustible; they are difficult to ignite, but will burn. Also "fire-rated" sheet rock is also considered combustible. Contact your local building officials about restrictions and installation requirements in your area.

Using shields to reduce clearances

Pipe shields: When using listed pipe shields to reduce the connector clearance to combustibles, it must start 1" above the lowest exposed point of the connect pipe and extend vertically a minimum of 25" above the top surface of the stove.

Double wall pipe: Listed double wall pipe is an acceptable alternative to connector pipe heatshields.

Wall-mounted protection: When reducing clearances through the use of wall mounted protection:

In the U.S. Refer to NFPA 211, standard for chimneys, fireplaces, vents and solid fuel burning appliances, for acceptable materials, proper sizing and construction guidelines.

In Canada, refer to CAN/CSA-B365, installation code for solid-fuel burning appliances and equipment, also for acceptable materials, proper sizing and construction guidelines.

Stove mounted rear heatshield is standard equipment on all Jøtul F 3 CB's. **No other stove-mounted heat shield may be used.**

Wall Shield for close clearance

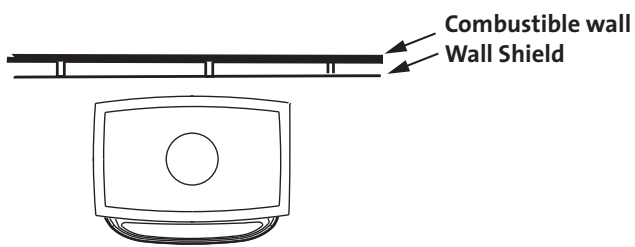

Must be 30" wide and centred behind the stove.
 Must be 1" off the wall and 1" off the floor.
 With standard legs, the shield must be 32" high.
 With optional short legs, the shield must be 30" high.

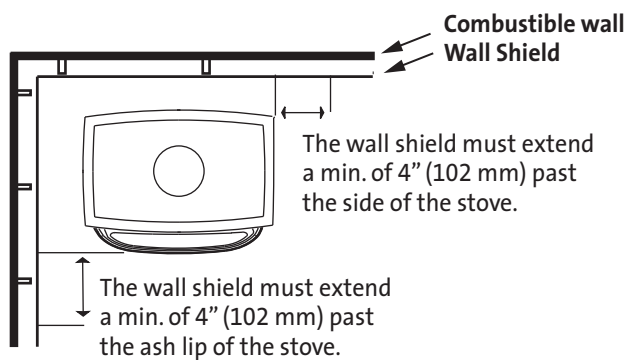

Must be 1" off the wall and 1" off the floor.
 With standard legs, the shield must be 40" high.
 With optional short legs, the shield must be 38" high.
 Both shields must extend and join in the corner.

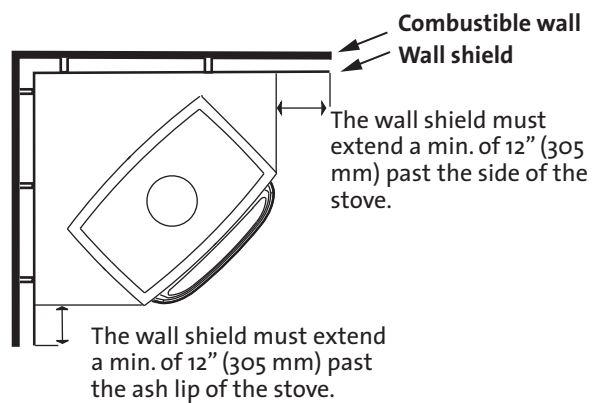

Must be 1" off the wall and 1" off the floor.
 With standard legs, the shield must be 40" high.
 With optional short legs, the shield must be 38" high.
 Both shields must extend and join in the corner.

USA/Canada

Jøtul F 3 CB Clearances

Stove Clearances Top vent/vertical	Unprotected Surfaces			Protected Surfaces per NFPA 211 or CAN/CSA-B365-M		
	Side	Rear	Corner	Side	Rear	Corner
Rear heatshield with Single wall pipe	24" 610mm	25" 635mm	18" 460mm	10" 255mm	14" 355mm	10" 255mm
Rear heatshield with Double wall pipe or shields	18" 460mm	10" 255mm	14" 355mm	6" 150mm	6" 150mm	6" 150mm

Stove Clearances Rear Vent/Horizontal	Unprotected Surfaces			Protected Surfaces per NFPA 211 or CAN/CSA-B365-M		
	Side	Rear	Corner	Side	Rear	Corner
Rear heatshield with Single wall pipe	24" 610mm	25" 635mm	20" 510mm	10" 255mm	25" 635mm	18" 460mm
Rear heatshield with Double wall pipe or shields	18" 460mm	14" 355mm	17" 430mm	6" 150mm	6" 150mm	6" 150mm

Connector Clearances	Unprotected Surface	Protected Surface per NFPA 211 or CAN/CSA-B365-M
	Singlewall pipe -vertical installations	18" (460mm)
Double wall pipe-vertical installations	pipe mfg. listing	pipe mfg. listing
Single wall pipe -horizontal installations	18" (460mm)	9" (230mm)
Double wall pipe-horizontal installations	pipe mfg. listing	pipe mfg. listing

Dimensions in Inches represent U.S. requirements.
Dimensions in Millimeters represent Canadian requirements.

Wall protection is discussed in further detail on page 10 of this manual.

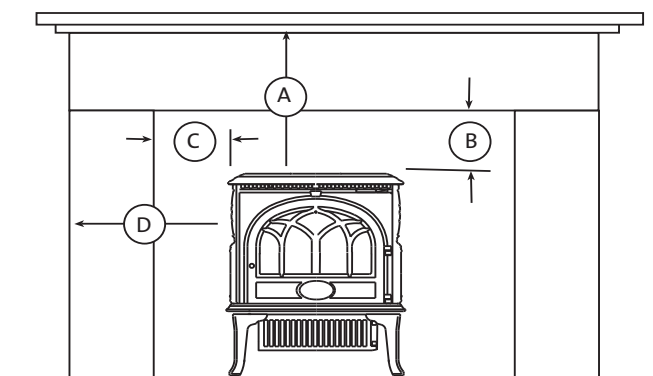

A: Top to Mantel	34"	860 mm
B: Top to Top Trim	20"	510 mm
C: Side to Side trim	13"	330 mm
D: Side to Side Wall	24"	610 mm

Maximum Mantel Depth:	11 1/2"	292 mm
Maximum Top and Side Trim Depth:	1 1/2"	38 mm

Notice

Accessories for woodstoves for clearance reduction have been developed by many manufacturers. If not following the methods of the installation codes, be sure that any accessory you choose has been tested by an independent laboratory and carries the laboratory's testing mark. Make sure to follow all of the manufacturer's instructions.

Always contact your local building inspector or fire officials about restriction and requirements in your area. Reminder, it is the local officials who have final authority in the installations approval.

Alcove

The Jøtul F 3 CB is approved for installations in an unprotected and protected alcove provided the following guidelines are followed: Stoves must be positioned as shown in figures 13 or 14.

Alcove floor protection must be: A UL/ULC or WHI listed hearth board or a non combustible material with a minimum r value of 1.1.

Minimum unprotected alcove:

Assumes-
Top exit, single wall pipe, and stove's rear heatshield.

Minimum alcove width = 71" (1805mm)
Maximum alcove depth = 40" (1015mm)
Height above the top of the stove = 68" (1730mm)

Top vent/vertical - assumes the connector pipe is exiting off the top of the stove and traveling vertically. If top vented to any horizontal runs – the stove's position is dictated by the connector pipe clearances.

Fig. 13

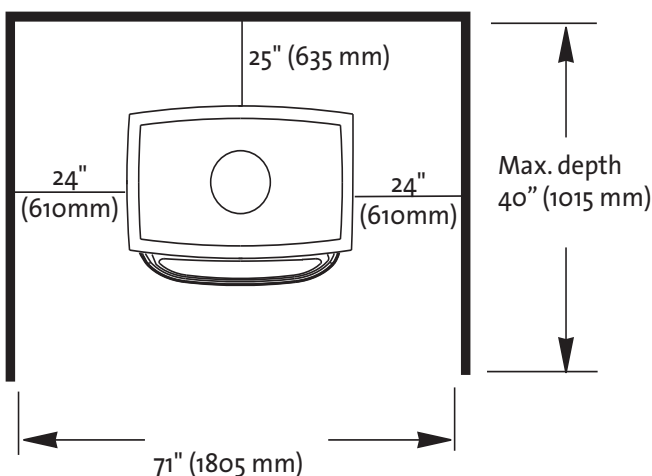

Minimum protected alcove:

Assumes-
Top exit, double wall pipe, and stove's rear heatshield.
Minimum alcove width = 35" (890mm)
Maximum alcove depth = 24" (610mm)
Height above the top of the stove = 40" (1015mm)

In a **protected** alcove installation both side walls and rear wall must be protected per NFPA 211 or CAN/CSA-B365. The wall protection must be elevated 1" from the floor and at least 1" off the combustible wall to allow for an air-flow.

Rear exit alcove installations:

Unprotected alcove: Assumes single wall pipe and stove's rear heatshield.

Fig. 14

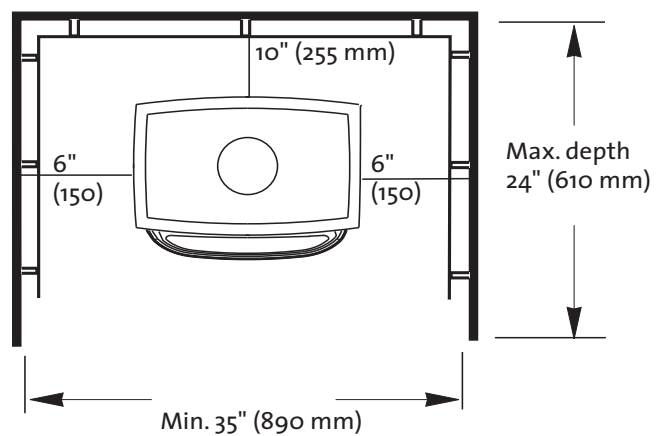

Minimum alcove width = 71" (1805 mm)
Maximum alcove depth = 40" (1015mm)
Alcove ceiling above top of stove = 68" (1730mm)

Protected alcove: Assumes double wall pipe and stove's rear heatshield.

Minimum alcove width = 35" (890mm)
Maximum alcove depth = 30" (760mm)
Alcove ceiling above top of stove = 40" (1015mm)

5.0 Operation

Before building a fire in your new Jøtul F 3 CB, please read the following section carefully and completely.

Do not burn

First this stove is designed to burn natural wood **only**, wood that has been air-dried for a period of 6 to 14 months will provide the cleanest most efficient heat.

Do not burn:

- *Coal
- *treated or painted wood
- *Garbage
- *chemical chimney cleaners
- *Cardboard
- *colored paper
- *Solvents
- *any synthetic fuel or logs

The burning of any of these materials can result in the release of toxic fumes. Never use gasoline, gasoline-type lantern fuel, kerosene, charcoal lighter fluid, or similar liquids to start or “freshen-up” the fire. Always keep such liquids away from the heater at all times.

Important

Never build or allow the fire to rest directly on the glass. The logs should always be spaced at least one inch from the glass to allow for proper air flow within the stove.

Controls on the Jøtul F 3 CB

There are two air controls on the Jøtul F 3.

The primary air control lever (**A**) is located on the front of the stove in the top right corner. The primary air lever controls the amount of air that enters the stove for combustion.

The start-up air control lever (**B**) is located below the glass in the center of the front door. This control is for “start-up” air only and should not be used to freshen an existing fire or during refueling. Never leave the stove unattended while this control is open, overfiring could result, which can damage the appliance. See **figure 15**.

Fig. 15

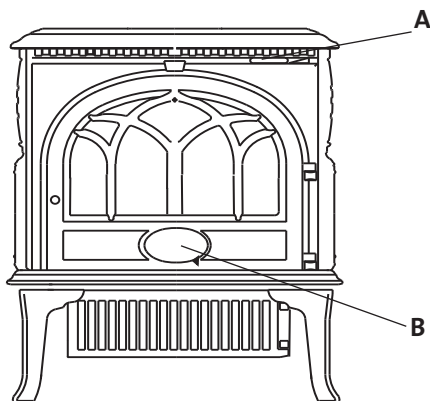

When first starting a fire: The primary control lever should be at the far right position, and the start-up air lever should be in the far right position. This will allow for the maximum amount of air to enter the stove and assist in starting the fire quickly and most effectively.

Once the fire is established the start-up air lever should be closed and the primary air lever should be adjusted according to the amount of heat desired.

Remember: The more air entering the stove the hotter the fire the shorter the burn time. Moving the primary air lever to the left reduces the air-flow into the stove which prolongs the fire at a lower heat output. See figure 15.

Breaking in your new stove

Your new Jøtul F 3 CB is constructed of cast iron and stove furnace cement. This type of construction requires the stove to be “broken-in” gradually so that heat expansion does not occur too quickly and cause damage.

To monitor the stove’s temperature, Jøtul recommends the use of a magnetic stove-top thermometer, placed directly on the corner of the stove’s top plate.

Complete the following steps for the proper break-in procedure for the Jøtul F 3 CB:

1. Light a small fire, newspaper and kindling only, only allow the stove to reach a maximum surface temperature of 200°. Burn for approximately 1 hour.
2. Allow stove to cool to room temperature.
3. Light a second fire, allowing the stove to reach a maximum temperature of 300° for 1 hour.
4. Cool the stove to room temperature.
5. Light a third fire and gradually allow the stove to reach a surface temperature of 400°
6. Cool stove to room temperature. This completes the “break-in” procedure.

Never allow the stove to exceed a 400° surface temperature during any “break-in fire” with the exception of the last “break-in” fire.

Note: It is normal for a new painted stove to emit an odor and even smoke during its first several fires. This is caused by the seasoning of the high temperature paint and will diminish with each fire and will eventually disappear. Opening a window or door to provide additional ventilation will reduce the odor as this process takes its course.

Never overfire the stove

If any part of the stove or chimney glows, you are overfiring, and a house fire or serious damage to the stove or chimney could result. Immediately close down the air control if you notice this condition.

Starting and maintaining a fire

Burn only solid wood directly on the bottom grate of the stove, do not elevate the fire in any way.

The ash pan door on the stove must always be securely closed when the stove is in operation.

Burning the stove with the ashpan open will over-fire the stove and cause interior damage.

With the primary air control lever and the start-up air control lever in the full open position (far right), start with several sheets of crumpled newspaper placed directly on the grate. On top of the newspaper, place several pieces of small dry kindling (approx. 1" in diameter) with two to three larger logs (approx. 3" to 5" in diameter) on top.

Light the fire and close the door, slowly building the fire by adding larger and larger logs. Close the start-up air control lever after the fire is established and new fuel lights easily. Be sure to follow the break-in procedure before creating a fire that will damage the stove.

Once the stove has reached a surface temperature range of between 400° and 600°, adjust the primary air control lever as necessary to generate the heat output and burn time desired.

Jøtul recommends the use of a magnetic stove top thermometer to monitor the surface temperature of the stove. The optimum surface temperature range for the most efficient burn is between 400° and 600°.

See **figure 16** below for the optimum locations of a stove-top thermometer.

Fig. 16

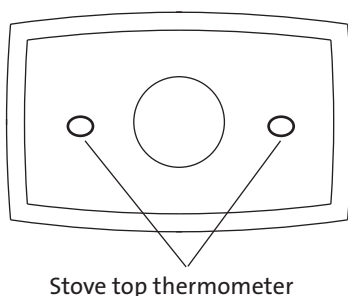

Adding fuel

When reloading the stove while it is still hot and a bed of hot embers still exist, follow this reloading procedure:

- Always wear gloves when tending to the stove.
- Push the air control lever to the full open position (far right).
- Wait a few seconds before opening the door.
- Use a stove tool or poker to distribute the hot embers equally around the firebox.
- Load the fuel, usually with smaller logs first.
- Close the door, be sure to latch the door tightly.
- Wait 5 – 10 minutes before adjusting the primary air to the desired heat output setting.

(If you have at least a 2" thick ember bed when reloading, it may be possible to close the door and immediately adjust the air control setting).

Creosote and Soot Formation and the Need for Removal

When wood is burned slowly, it produces tar and other organic vapors which combine with expelled moisture to form creosote. These creosote vapors condense in the relatively cool chimney flue of a slow burning fire. The creosote that accumulates in the flue is highly flammable and is the fuel of chimney fires. To prevent a chimney fire, the creosote needs to be removed by sweeping the chimney and flue connector. The frequency of sweeping will depend on how you operate your stove, but it is important to inspect the flue after every two months of use. An accumulation of 1/4" or more on the sides of the flue or connector is considered hazardous and should be removed.

In the event that creosote in your chimney or flue connector ignites, the resulting fire is often accompanied by a roaring noise and a crackling sound as flakes of burned creosote break loose. If you suspect you are having a chimney fire, immediately close the draft regulator and make sure the stove door is closed. Call the fire department and get everyone safely out of the house.

Trying to extinguish the fire in the stove will not help. In fact it can make the matter worse by allowing oxygen through the door, which then supports the fire in the chimney. When the roaring and crackling has stopped, you should resist the temptation to open the door and look at the fire. The fire may have suffocated, but could rekindle when you open the door. After a chimney fire, do not use your stove until the chimney and the flue connector has been cleaned and inspected to ensure that no damage has been sustained.

6.0 Maintenance

Ash removal: Of course, for your protection always wear safety gloves when handling the ash pan.

Ash removal will be required periodically depending on how frequently the stove is used. Conveniently, the Jøtul F 3 is equipped with an ash pan assembly for easy ash removal, without the need for opening the front doors.

The ash pan door is located under the front ashlip of the stove. To open the ash door rotate the door knob counterclockwise to unlatch the door and clockwise to latch the door.

Remove the ash pan. When the stove is in operation always close the ash pan door before leaving to dispose of the ashes.

The ashes should be placed in a metal container equipped with a tight sealing lid. The container should be placed on a noncombustible floor or on the ground, well away from all combustible materials, pending final disposal. If the ashes are disposed of by burial in soil or otherwise locally dispersed, they should be retained in the closed container until all cinders have thoroughly cooled.

Glass care

Cleaning: On occasion it will be necessary to clean the carbon deposits and fly ash off of the glass. If the carbon and fly ash are allowed to remain on the glass for an extended period of time it could eventually cause the glass to become etched and cloudy. Any creosote, which might deposit on the glass, will burn off during the next hot fire.

The proper cleaning procedure is as follows:

1. Glass needs to be **completely cool**.
2. Only use a cleaner that is specifically designed for this purpose. The use of abrasives will damage the glass and ultimately leave the glass frosted.
3. Rinse and dry glass completely, before burning your stove.

Important:

Replace glass only with a ceramic glass panel specifically designed for the Jøtul F 3 CB. Do not use substitutes. Replacement glass panels can be ordered through your Jøtul dealer.

Glass removal: Always operate the doors slowly and cautiously to avoid cracking or breaking the glass. Never use the door to push wood into the firebox. If the glass becomes cracked or broken follow this procedure for replacement:

Never operate the stove with a cracked or broken glass panel.

1. Remove the door from the stove and place on a flat surface.
2. Carefully remove all of the glass clips from the inside of the door.
3. Gently remove all pieces of the glass panel and gasketing.
4. Remove all remaining debris from the glass area using a wire brush.
5. Apply a small bead of gasket/stove cement and the new gasket. Do not overlap the ends of the gasket rope.
6. Center the new glass panel over the gasket and reinstall the glass clips. See **figure 17**.
Important: The side of the glass treated with an infrared coating (marked on the perimeter) should always be facing outward. It is extremely important to tighten the glass clips slowly and in a repeating pattern, like tightening the lugs on an automobile wheel.
7. It may be necessary to retighten the glass clips after the stove has been burned and the gasketing has been seated.

Chimney System

The Jøtul F 3 CB is designed to burn cleanly and efficiently when used according to the guidelines in this manual. In order to maintain proper performance, you should inspect the chimney and chimney connector at the beginning of each heating season and then, every other month during the heating season. Clean the chimney whenever creosote and fly ash accumulation exceeds 1/4 inch in any part of the system.

Chimney brushes are available from your local Jøtul dealer or hardware supply store. Your dealer can also refer you to a reputable, professional chimney sweep who will have all the equipment to ensure a complete and proper job. Failure to keep the chimney system free of creosote and build up

could result in a serious chimney fire.

7.0 General Maintenance

As with your car, regular maintenance will prolong the life of your stove and ensure satisfactory performance.

The following procedures do not take long and are generally inexpensive, but when done consistently, increase the life of your appliance and in turn, increase your years of enjoyment.

Enamel Care

- DO NOT ATTEMPT TO CLEAN HOT ENAMEL SURFACES. Clean only cold enamel surfaces with a soft damp cloth and polish with a clean dry cloth. DO NOT USE SOAPY OR ABRASIVE SOLUTIONS. These can cause stains. Coffee, tea, and fruit juices will also cause stains.
- Avoid contact with metal objects. Trivets, kettles, or pots, can damage the enamel.
- Empty stove of all soot and ashes. Only use a vacuum for this job if the vacuum is specifically designed for ashes.
- Inspect the stove seams. Use a utility light to inspect the stove inside and out for cracks or leaks. Replace all cracked parts and repair any cement leaks with furnace cement.

Gasket list for the Jøtul F 3 CB

Description	Order #	Size	Length
Top plate gasket	100038	3/8" Id	6'
Ash housing gasket	128213	sheet gasket	
Ash door gasket	200024	1/4" Id	3'
Glass gasket	200028	1/4" Id	3'6"
Door gasket	200024	11/32" Id	5'
Air manifold Gasket	200028	3/16"	16"

Fig. 17

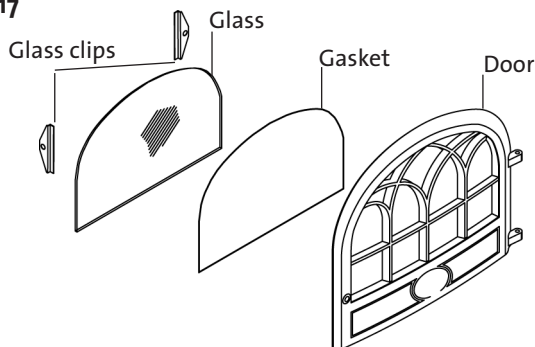

Gaskets

Check door and window gaskets for tightness. To check the seal of the front doors, close and latch the doors on a dollar bill and slowly try to pull the dollar bill free. If it can be easily removed then the seal is too loose. Check several spots around the door, and repeat the procedure on the ash pan door as well.

If gaskets need to be replaced, scrape out the old gasket and cement and clean the area with a wire brush. Apply a small bead of cement and push in the new gasket. After closing and latching the doors wipe clean, any excessive cement that has come from beneath the gasketing.

8.0 Accessories

Only use accessories that are specifically designed for the Jøtul F 3 CB.

Firescreen (part # 350168)

The Jøtul F 3 CB has been approved for use as an open fireplace, with front door open. This feature is especially nice when the ambience of a fire is desired. Some care should be taken when operating the stove as a fireplace.

- Always have the firescreen in place, attached to the stove front.
- Never over load the stove, for the best appearance burn in the traditional three log configuration.
- Reminder, when burning the stove with the screen in place, you are sacrificing efficiency for aesthetics, and you will be consuming wood at a much faster rate.

Warning: Operate your Jøtul F 3 CB with the front door fully open and the firescreen in place or fully closed. A partially opened door may result in overfiring. Also, if the door is left partly open, gas and flame may be drawn out of the stove opening, creating risks from both fire and smoke.

Floor bracket kit (part # 750304)

The optional floor bracket kit can be used in the event the stove needs to be secured to the floor. Complete installation instructions and diagrams are supplied with each floor bracket kit.

Stove-top thermometer (part # 5002)

Jøtul recommends the use of a magnetic stove-top thermometer to monitor the surface temperature of the stove. The optimum surface temperature range for the most efficient, clean burn is between 400° and 600°.

Appendix A:

Alternate floor protection

All floor protection materials must be non-combustible (ie. Metal, brick, stone, mineral fiber boards). Any combustible material may not be used.

The easiest means of determining if a proposed alternate floor material meets requirements listed in this manual is to follow this procedure.

R-value = thermal resistance
K-value = thermal conductivity
C-value = thermal conductance

1. Convert the specification to r-value;
 - a. If r-value is given, no conversion is needed.
 - b. If k-value is given with a required thickness (t) in inches:
 $R=1/k \times T$.
 - c. If c-value is given: $R=1/C$.
2. Determine the r-value of the proposed alternate floor protector.
 - a. Use the formula in step 1 to convert values not expressed as "R".
 - b. For multiple layers, add r-values of each layer to determine overall r-value.
3. If the overall R-value of the system is greater than the R-value of the specified floor protector, the alternate is acceptable.

Example:

The specified floor protector should be 3/4" thick material with a k-factor of 0.84. The proposed alternate is 4" brick with a c-factor of 1.25 over 1/8" mineral board with a k-factor of 0.29.

Step A. Use formula above to convert specifications to R-value. $R=1/k \times t= 1/.84 \times .75 = .893$

Step B. Calculate r of proposed system.

4" brick of c-1.25, therefore

$R \text{ brick} = 1/c = 1/1.25 = 0.80$

1/8" mineral board of $K = 0.29$ therefore

$R \text{ mineral board} = 1/.29 \times 0.125 = 0.431$

Total $R = R \text{ brick} + R \text{ mineral board} = 0.8 + 0.431 = 1.231$

Step C. Compare proposed system $R = 1.231$ to specified R of 0.893. Since R is greater than required, the system is acceptable.

Definitions:

Thermal conductance =

$$C = \frac{\text{btu}}{(\text{Hr})(\text{ft}^2)(\text{f})} = \frac{W}{(\text{m}^2)(\text{k})}$$

Thermal conductivity =

$$K = \frac{\text{btu}}{(\text{Hr})(\text{ft}^2)(\text{f})} = \frac{W}{(\text{m}^2)(\text{k})} = \frac{(\text{btu})}{(\text{hr})(\text{ft})(\text{f})}$$

Thermal resistance =

$$R = \frac{\text{btu}}{(\text{Hr})(\text{ft}^2)(\text{f})} = \frac{(\text{m}^2)(\text{k})}{W} = \frac{(\text{btu})(\text{inch})}{(\text{hr})(\text{ft}^2)(\text{f})}$$

For the Jøtul F 3 CB requires floor protection with a **minimum insulating R-value of 1.1.**

Alcove installation require a minimum R-value of 1.1. (If a UL/ULC or WHI listed hearth pad is not used.)

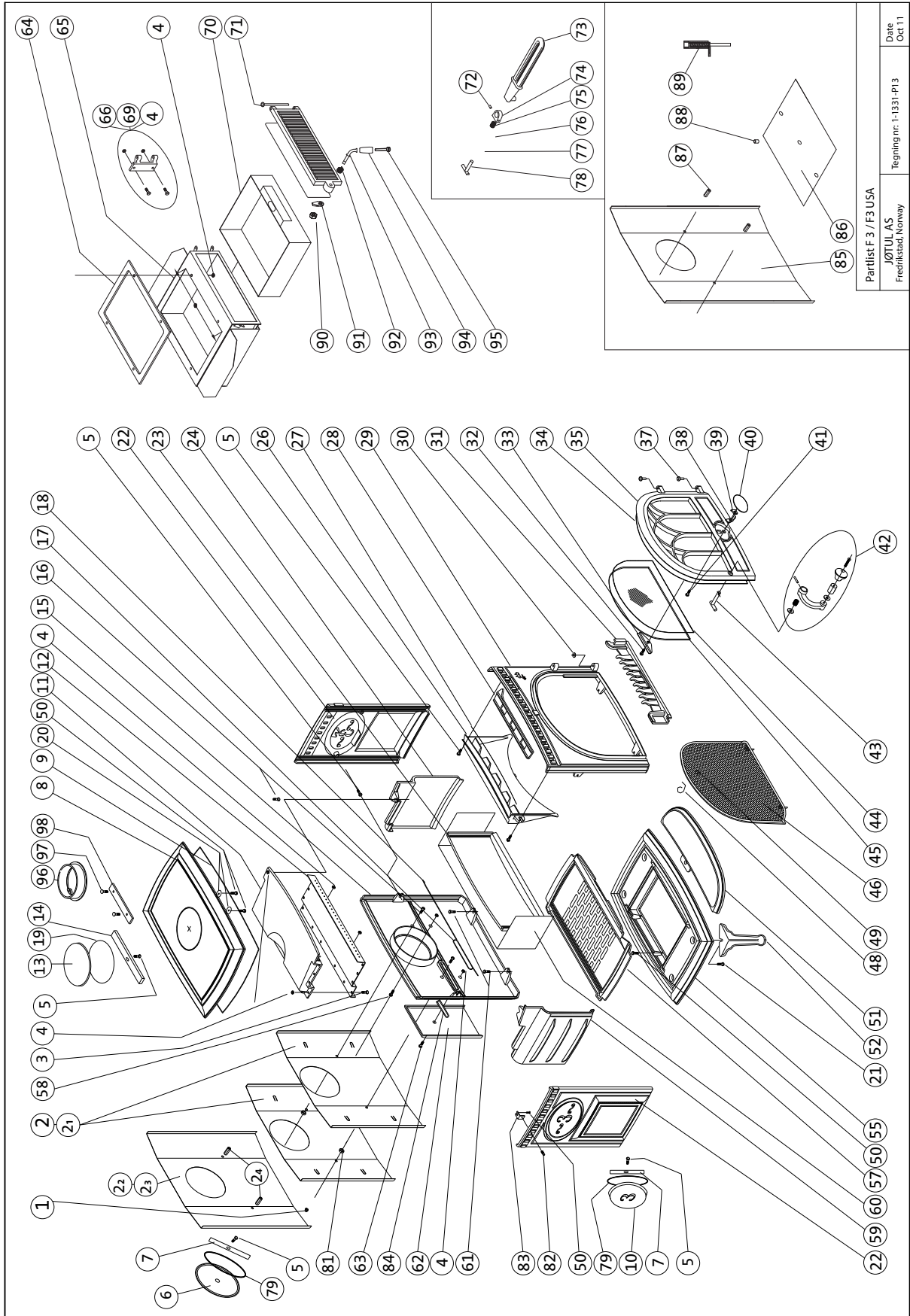

Partlist F 3 / F3 USA	Date
JØTUL AS	Oct 11
Fredrikstad, Norway	
Tegning nr: 1-1331-PI3	

Part list for Jøtul F 3 CB

No Description, Dim./Spec.

- | | |
|--|---|
| 1 Nut brass, M6x20 DIN 1587 | 59 Burn plate left |
| 2 Heat shield aluz. f/ivory en. | 60 Insulation, Firemaster blanket (after X-607) |
| 2 b Heat shield | 61 Screw , M8x25 st.8.8 |
| 3 Screw, M6x16 DIN 965 | 62 Cover/sec. air inlet, |
| 4 Nut , M6 DIN 934 | 63 Screw sinkhead, M6x40 poz DIN 965 |
| 5 Screw collar, M6x16 st.5.6 ubeh. | 64 Gasket-flat |
| 6 Cover smoke outlet rear | 65 Ash house w\ heat shield and hinge (after 1998) |
| 7 Traverse bar to cover smoke outlet rear | 66 Hinge, ash house (before 1998) |
| 8 Top plate compl. w/ cover smoke outlet | 69 Screw sh Pozid, M6x10 DIN 965 (before 1998) |
| 9 Gasket, LD 375-2 9.5x1800 | 70 Ash box, 1mm steel plate |
| 10 Cover smoke outlet side | 71 Hinge pin, Ø6x100 |
| 11 Baffle plate | 72 Locking screw, M6x10 DIN915 |
| 12 Air distributor USA | 73 Handle for ashdoor |
| 13 Cover smoke outlet top | 74 Handle stub |
| 14 Traverse/cover smoke outlet top | 75 Spring |
| 15 Back plate | 76 Door ashroom complete, |
| 16 Screw, M6x35 st.5.6 ubeh | 77 Gasket, LD 250-2 Ø6.4x730 |
| 17 Gasket, LD 360 M/L Ø8.7x150 | 78 Door latch |
| 18 Gasket, LD 360 M/L Ø8.7x560 | 79 Gasket, LD 250 m\l Ø6,4x600 |
| 19 Gasket, LD 250-2 M/L Ø6,4x540 | 81 Hexagon nut, M8 DIN 934 |
| 20 Cast iron washer | 82 Locking pin, M6x20 DIN 914 |
| 21 Screw, M8x20 st.8.8 | 83 Fixing bracket |
| 22 Side plate | 84 Air blocker (for USA) |
| 23 Burn plate, back | 85 Heat shield rear (for Germany) |
| 24 Burn plate right | 86 Heat shield under (for Germany) |
| 26 Air deflektor | 87 Extention nut for heat shield, rear (for Germany)
M6x18mm |
| 27 Gasket, LD 187-1 M/L 4.8x410 | 88 Distance sleeve for heatshield, under (for Germany)
Ø10xØ6,2x15mm |
| 28 Sliding vent | 89 Self closing mechanism (for Germany) |
| 29 Front plate | 90 Nut , M10 DIN 934 |
| 30 Washer, Ø12x6x0.5 | 91 Door latch, 3mm stainless steel |
| 31 Log retainer. | 92 Spring Ø10 inside, 2mm stainless steel |
| 32 Screw, M6x8 poz | 93 latch bolt ash door, Steel |
| 33 Glass clip w\ gasket | 94 Wooden knob, Hard wood |
| 34 Gasket, LD 360 Ø8.7x1480 | 95 Skrew, M6x60 DIN 84 |
| 35 Door compl. w/o glass | 96 Cast iron flue collar |
| 37 Hinge pin, Ø0,6x33 | 97 Screw, M6 x 40 mm hex hd |
| 38 Ignition vent | 98 Flue Collar Cross Bar |
| 39 Washer, D nr. 531241 | |
| 40 Cover/ign. vent | |
| 41 Screw/collar, M6x12 st. 8.8 ubeh. | |
| 42 Handle compl., nickel-plated | |
| 43 Locking bar | |
| 44 Gasket, LD 187 m\l Ø4,8x1800 | |
| 45 Glass , 358 x 233 mm | |
| 46 Spark screen | |
| 48 Spring | |
| 49 Knob, plastic, 0,30mm M6 | |
| 50 Screw collar, M6x16 st. 5.6 | |
| 51 Ash lip | |
| 52 Leg | |
| 53 Skrew M6x20 ST 8,8 ubeh. | |
| 54 Washer, Ø18x0,6, 4x1 | |
| 55 Bottom plate, | |
| 57 Inner bottom plate | |
| 58 Screw sink head, M6x25 sortkrom.poz. (black-poz.) | |

1-1331-P23

Only use replacements parts provided through your authorized Jøtul dealer.

USA/Canada

9.0 JØTUL N.A. WOOD-BURNING PRODUCT LIMITED LIFETIME WARRANTY

Effective January 1, 2013

This warranty policy applies to wood-burning products identified by Jøtul and Scan trade names, as set forth below.

A. LIMITED LIFETIME WARRANTY, parts only:

Jøtul North America Inc. (JØTUL) warrants, to the original retail purchaser, that those baffle and air manifold components of the Jøtul or Scan Stove or Fireplace Insert specified above will be free of defects in material and workmanship for the life of the product. This warranty is subject to the terms, exclusions and limitations set forth below.

B. LIMITED FIVE YEAR WARRANTY - Cast Iron and Steel Components:

JØTUL warrants, to the original retail purchaser, that those components of the Jøtul or Scan Stove or Fireplace Insert specified above will be free of defects in material and workmanship for a period of five (5) years from the date of purchase. This warranty is subject to the terms, exclusions and limitations set forth below.

C. LIMITED TWO YEAR WARRANTY - Enamel Finish:

JØTUL warrants, to the original retail purchaser, the enamel finish on cast iron components of the Jøtul Stove or Fireplace Insert specified above against peeling or fading for a period of two (2) years from the date of purchase. This warranty is subject to the terms, exclusions and limitations set forth below.

D. LIMITED ONE YEAR WARRANTY - Electrical Components (blowers, thermostatic switches):

JØTUL warrants, to the original retail purchaser, that those components of the Jøtul or Scan Stove or Fireplace Insert specified above will be free of defects in material and workmanship for a period of one (1) year from the date of purchase. This warranty is subject to the terms, exclusions, and limitations set forth below:

JØTUL will repair or replace, at its option, any of the above components determined by JØTUL to be covered by this warranty. You must, at your own expense, arrange to deliver or ship the component to an authorized Jøtul or Scan dealer and arrange for pickup or delivery of the component after repairs have been made. If, upon inspection, JØTUL determines that the component is covered by this warranty, the repair or replacement will be made as set forth above. This warranty is not transferable and is extended only to, and is solely for the benefit of, the original retail purchaser of the Jøtul or Scan Stove or Fireplace Insert. This paragraph sets forth the sole remedy available under this warranty in the event of any defect in the Jøtul Scan Stove or Fireplace Insert.

The warranty period for any replaced component will be the remaining unexpired portion of the warranty period for the original component.

Please retain your dated sales receipt in your records as proof of purchase.

EXCLUSIONS AND LIMITATIONS

NOTICE: This warranty is void if installation or service is performed by someone other than an authorized installer or service agency, or if installation is not in conformance with the installation and operating instructions contained in this owner's manual or local and/or national fire and building regulations. A listing of local authorized installers, service agencies and gas suppliers can be obtained from the National Fireplace Institute at <http://www.nficertified.org/>.

This warranty does not cover the following:

1. Repair or replacement of parts that are subject to normal wear and tear during the warranty period or to parts that may require replacement in connection with normal maintenance. These parts include paint, gaskets, burn plates, ceramic insulation blankets, skamol baffles and panels, firebricks, fire grates, or glass (Ceramic glass is warranted against thermal breakage only).
2. Damage due to incorrect installations not in conformance with the installation instructions contained in this owner's manual or local and/or national fire and building regulations.
3. Damage, including damage to enamel surfaces, caused by improper operation, over-firing, and/or misuse. Improper operation, such as burning the stove with the ash door open, can damage the stove. Over-firing occurs when any part of the stove glows red. Over-firing can also be identified by warped plates, rust-colored cast iron, paint pigment that has turned dusty white, or bubbling, cracking and discoloration of the enamel finish. Misuse includes, without limitation, use that is not in conformance with the operating instructions contained in this owner's manual.

4. Damage to enamel finish including chipping, mechanical or chemical abrasion, crazing, staining, or rust caused by high humidity or salt air environments.
5. Damage from or repair of rust. Use of a stove-top steamer can cause rust.
6. Damage due to service performed by an installer or service agency, unless otherwise agreed to in writing by JØTUL.
7. Damage caused by unauthorized modification, use or repair.
8. Costs incurred by travel time and/or loss of service.
9. Labor or other costs associated with the repair of components beyond the warranty period.
10. Damage incurred while the Jøtul or Scan Stove or Fireplace is in transit.

IN NO EVENT SHALL JØTUL, ITS PARENT COMPANY, SHAREHOLDERS, AFFILIATES, OFFICERS, EMPLOYEES, AGENTS OR REPRESENTATIVES BE LIABLE OR RESPONSIBLE TO YOU FOR ANY SPECIAL, INDIRECT, INCIDENTAL, CONSEQUENTIAL, PUNITIVE OR OTHER SIMILAR DAMAGES, INCLUDING, BUT NOT LIMITED TO, LOST PROFITS, LOST SALES, INJURY TO PERSON OR PROPERTY, OR DAMAGES TO A STRUCTURE OR ITS CONTENTS, ARISING UNDER ANY THEORY OF LAW WHATSOEVER. ALL IMPLIED WARRANTIES, INCLUDING THE IMPLIED WARRANTIES OF MERCHANTABILITY AND FITNESS FOR A PARTICULAR PURPOSE, OR OTHERWISE, ARE LIMITED IN DURATION TO THE LENGTH OF THIS WRITTEN WARRANTY. EXCEPT AS EXPRESSLY SET FORTH HEREIN, JØTUL MAKES NO ORAL, WRITTEN OR OTHER WARRANTY WITH RESPECT TO JØTUL OR SCAN STOVES OR FIREPLACES.

Some states do not allow the exclusion or limitation of incidental or consequential damages, or limitations on the length of implied warranties. Therefore, the above exclusions or limitations may not apply to you. This warranty gives you specific legal rights, and you may have other rights, which vary from state to state.

JØTUL reserves the right to discontinue, modify or change the materials used to produce the Jøtul or Scan Stove or Fireplace Insert. JØTUL shall have the right to replace any defective component with substitute components determined by JØTUL to be of substantially equal quality and price.

The dollar value of JØTUL's liability for breach of this warranty shall be limited exclusively to the cost of furnishing a replacement component. JØTUL may at its discretion discharge all obligations by refunding the wholesale price of any defective part or appliance. JØTUL shall in no event be liable for any special, indirect or consequential damage of any nature which is in excess of the original wholesale purchase price of the product. JØTUL shall not in any event be liable for the cost of labor expended by others in connection with any defective component. Any costs or expenses beyond those expressly assumed by JØTUL under the terms of this warranty shall be the sole responsibility of the owner(s) of the Jøtul Stove or Fireplace.

No dealer, distributor, or other person is authorized to modify, augment, or extend this limited warranty on behalf of JØTUL. **NO MODIFICATION OR CHANGE TO THIS WARRANTY WILL BE EFFECTIVE UNLESS IT IS MADE IN A WRITTEN DOCUMENT MANUALLY SIGNED BY AN AUTHORIZED OFFICER OF JØTUL.**

An authorized installer may have been provided with certain information related particularly to the Jøtul or Scan Stove or Fireplace; however, no authorized installer or other person who may service the appliance is an agent of JØTUL. No inference should be made that JØTUL has tested, certified, or otherwise pronounced any person as qualified to install or service the appliance. JØTUL shall not be liable or otherwise responsible for any error or omission by a person installing or servicing a Jøtul or Scan Stove or Fireplace Insert.

If you believe your Jøtul or Scan Stove or Fireplace Insert is defective, you should contact your nearest authorized Jøtul dealer, who will process a warranty claim. **IN ORDER TO QUALIFY FOR WARRANTY COVERAGE, JØTUL MUST RECEIVE NOTICE OF A POSSIBLE DEFECT WITHIN SIXTY (60) DAYS OF THE DATE THE DEFECT IS FIRST DISCOVERED, OR REASONABLY COULD HAVE BEEN DISCOVERED.**

*This warranty is given by Jøtul North America, Inc.,
55 Hutcherson Drive, Gorham, Maine 04038 USA*

139676_R00
January 2015

Jøtul pursues a policy of continuous product development. Products supplied may therefore differ in specification, colour and type of accessories from those illustrated and described in the brochure.

J



Jøtul North America Inc
55 Hutcherson Drive
Gorham, Maine 04038, USA

Jøtul AS,
P.o. box 1411
N-1602 Fredrikstad,
Norway
www.jotul.com