

**Jøtul GF 500 DV
Portland**
Direct Vent Gas Stove

Standing Pilot Ignition

Installation and Operation Instructions



INSTALLER: Leave this manual with the appliance.
CONSUMER: Retain this manual for future reference.

WARNING: If the information in these instructions is not followed exactly, a fire or explosion may result causing property damage, personal injury or loss of life.

- Do not store or use gasoline or other flammable vapors and liquids in the vicinity of this or any other appliance.
- **WHAT TO DO IF YOU SMELL GAS**
 - Do not try to light any appliance.
 - Do not touch any electrical switch; do not use any phone in your building.
 - Immediately call your gas supplier from a neighbor's phone. Follow the gas supplier's instructions.
 - If you cannot reach your gas supplier, call the fire department.
- Installation and service must be performed by a qualified installer, service agency or the gas supplier.
- In the Commonwealth of Massachusetts, a carbon monoxide (CO) detector shall be installed in the same room as the appliance.

This appliance may be installed in an aftermarket, permanently located, manufactured home or mobile home, where not prohibited by local codes.

This appliance is only for use with the types of gas indicated on the rating plate. A conversion kit is supplied with the appliance.

⚠ DANGER

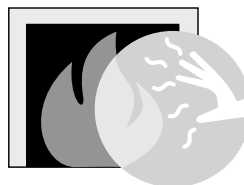

**HOT GLASS WILL
CAUSE BURNS.
DO NOT TOUCH GLASS
UNTIL COOLED.
NEVER ALLOW CHILDREN
TO TOUCH GLASS.**

A barrier designed to reduce the burn hazard from the glass viewing area is provided with this appliance and shall be installed for the protection of children and other at-risk individuals.

THIS OWNER'S MANUAL PROVIDES INFORMATION TO ENSURE SAFE INSTALLATION AND EFFICIENT, DEPENDABLE OPERATION OF THIS APPLIANCE. PLEASE READ THESE INSTRUCTIONS IN THEIR ENTIRETY AND MAKE THEM AVAILABLE TO ANYONE USING OR SERVICING THIS GAS STOVE.

DO NOT ATTEMPT TO ALTER OR MODIFY THE CONSTRUCTION OF THIS APPLIANCE OR ITS COMPONENTS. ANY MODIFICATION OR ALTERATION WILL VOID THE WARRANTY, CERTIFICATION AND LISTING OF THIS APPLIANCE.

THIS APPLIANCE MUST BE INSTALLED AND MAINTAINED BY A QUALIFIED SERVICE TECHNICIAN OR AGENCY.

Suggested Tools for Installation and Service

- External regulator (for Propane only)
- Piping which complies with local code
- Manual shut-off valve - T-Handle required in Massachusetts
- Sediment trap - if required by code
- Tee joint
- Pipe wrench
- Pipe sealant
- 10 mm open end wrench
- 1/2", 7/16" open end wrench
- Phillips head screwdriver
- Flat head screwdriver
- 1/4" nut driver
- Gloves
- Safety glasses
- Torx T-20 screwdriver
- Tin snips

PLEASE NOTE:

It is normal for smoke and odor to occur during the initial stages of operation, depending upon temperatures generated over time. This "curing" condition can be alleviated by promoting fresh air circulation within the immediate vicinity of the appliance.

Installation Requirements for the Commonwealth of Massachusetts

THIS PRODUCT MUST BE INSTALLED BY A LICENSED MASTER OR JOURNEYMAN PLUMBER OR GAS-FITTER WHEN INSTALLED IN THE COMMONWEALTH OF MASSACHUSETTS.

1. If there is not one already present, on each floor level where there are bedroom(s), a carbon monoxide detector and alarm shall be placed in the living area outside the bedroom(s). The carbon monoxide detector shall comply with NFPA 720 (2005 Edition).
2. A carbon monoxide detector shall:
 - a) Be located in the room that houses the appliance or equipment;
 - b) Be either hard-wired or battery powered or both; and
 - c) Shall comply with NFPA 720 (2005 Edition).
3. A Product-approved vent terminal must be used, and if applicable, a Product-approved air intake must be used. Installation shall be in strict compliance with the manufacturer's instructions. A copy of the installation instructions must remain with the appliance or equipment at the completion of the installation.

**NATIONAL
FIREPLACE
INSTITUTE**



CERTIFIED
www.nficertified.org

We recommend that our gas products be installed and serviced by professionals who are certified in the U.S. by the National Fireplace Institute® (NFI) as NFI Gas Specialists.

Canada

ENERGUIDE

Gas Fireplace Energy Efficiency Rating

Natural Gas / 74.57%
Propane / 75.31%

Based on CSA P4.1-02

Model No. Jøtul GF 500 DV



Table of Contents

Service Tools	2
Specifications	4
Initial Assembly	5
Rear Exit Vent Conversion	6
General Information.....	7
Safety Information	7
Installation Requirements	8
Location	8
Floor Protection	8
Clearances	8
Alcove	8
Mantel & Trim	9
Venting Requirements.....	10
Vent Restriction.....	10
Termination Matrix	11
Vertical Termination.....	12
Horizontal Termination.....	14
Vent Terminal Clearances	16
Fuel Conversion.....	17
Gas Connection.....	20
Gas Pressure	21
High Altitude Adjustment	21
Optional Wall Thermostat.....	22
Optional Brick Panel Installation	22
Optional Blower Installation	23
Log Set Installation	25
System Check	26
Flame Picture Adjustment	27
Operation Guidelines	28
Maintenance	29
Appendix	30
Mobile Home Requirements	30
Accessory Listing	30
Illustrated Parts Lists	31
Warranty Statement.....	35
Lighting Instructions	39

Jøtul GF 500 DV Portland

Direct Vent Gas Heater

Manufactured and Distributed by:
Jøtul North America
55 Hutcherson Dr.
Gorham, Maine 04038

Certified Test Standards

This appliance complies with National Safety standards and is tested and listed by Intertek Testing Services of Middleton, Wisconsin to ANSI Z21.88-2014, CSA 2.33-2014, CAN/CGA 2.17-M91, and CSA P.4-01.2



WARNING:

READ AND UNDERSTAND ALL OPERATING INSTRUCTIONS BEFORE ATTEMPTING TO OPERATE THIS APPLIANCE. DO NOT ALLOW ANYONE TO OPERATE THIS APPLIANCE WHO HAS NOT READ AND UNDERSTOOD THESE INSTRUCTIONS. KEEP THE REMOTE CONTROL TRANSMITTER WHERE CHILDREN CANNOT REACH IT.

WARNING:

SEVERE INJURY. THIS APPLIANCE CAN BE SET TO OPERATE THERMOSTATICALLY. BE AWARE THAT THE STOVE MAY BE VERY HOT EVEN WHEN THE BURNER IS NOT APPARENTLY OPERATING. KEEP CHILDREN AWAY FROM THE APPLIANCE.

WARNING:

FIRE HAZARD. CAN CAUSE SEVERE INJURY OR DEATH. THE APPLIANCE CAN TURN ON SUDDENLY. KEEP AWAY FROM THE APPLIANCE BURNER WHEN OPERATING THE REMOTE SYSTEM.

GF 500 DV Specifications

Input Rates

Natural Gas

40,000 BTU/hr. maximum input
12,800 BTU/hr. minimum input

Propane

39,500 BTU/hr. maximum input
14,000 BTU/hr. minimum input

Inlet Pressure:	MIN	MAX
Natural Gas:	5.0 WC (1.25 kPa)	7.0 WC (1.74 kPa)
Propane:	12.0 WC (3.0 kPa)	14.0 WC (3.48 kPa)

Manifold Pressure:	MIN	MAX
Natural Gas:	1.2 WC (.30 kPa)	3.80 WC (.95 kPa)
Propane:	2.9 WC (.72 kPa)	11.0 WC (2.74 kPa)

FAMILIARIZE YOURSELF WITH THE VENTING, CLEARANCE AND OTHER INSTALLATION REQUIREMENTS IN THIS MANUAL BEFORE BEGINNING THE INSTALLATION.

THIS APPLIANCE IS SHIPPED FROM THE FACTORY FOR USE WITH NATURAL GAS ONLY. FOR USE WITH PROPANE, THE APPLIANCE MUST FIRST BE CONVERTED USING THE FUEL CONVERSION KIT PROVIDED, #157865. CONVERSION SHOULD BE MADE BEFORE THE APPLIANCE IS INSTALLED. SEE PG. 17.

- SIT Nova 820 Millivolt System - Piezo Ignitor
- Steady State Efficiency: NG - 79.65% LP - 81.13%
- AFUE Efficiency: NG - 67.4% LP - 67.1%
- CSA P4. 1-02 Fireplace Efficiency:
NG - 74.57% LP - 75.31%
- Factory Air Shutter Settings: NG - 1/16" LP - 1/8"
- Ambient Temperature Range: 32 - 212°F (0 - 100°C)
Nova 820 High-Temp Valve

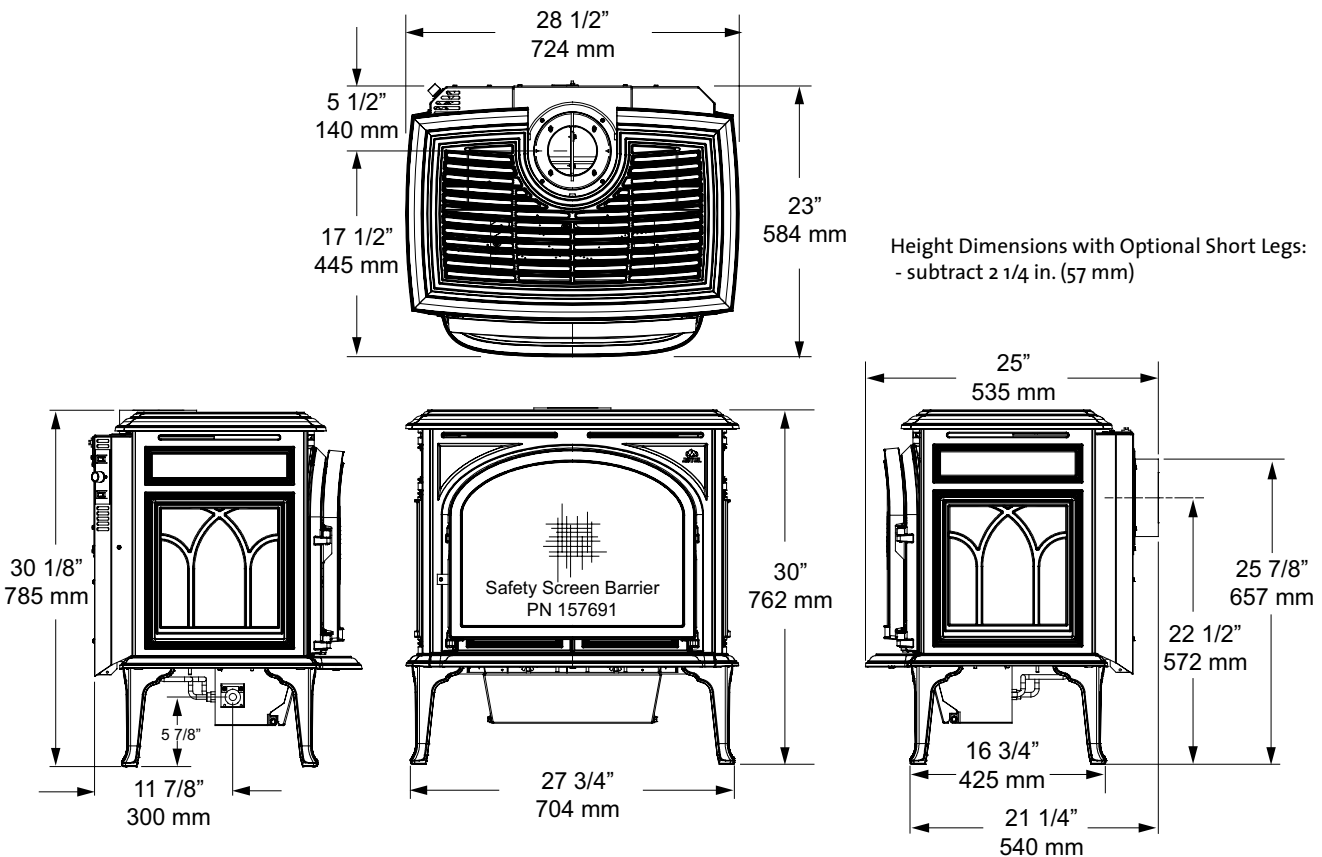

Figure 1. Dimensioned views, GF 500 DV

Initial Assembly

CAUTION: Enamelled parts may be damaged if handled without care. The stove is heavy. Have assistance available to move the stove. Place removed parts on a towel or other protective material.

1. **SAFETY BARRIER SCREEN:** This appliance is equipped with a Certified Barrier Screen that must be installed before operating the unit. It is secured to the shipping pallet. Remove two screws and use pliers to break off each perforated section from both screen frame attachment brackets. See fig. 2.

The barrier assembly attaches to the stove front by engaging the nylon-tipped mounting brackets over the stove door hinge bosses. The barrier may be installed with the stove doors either open or closed.

2. Remove the Top Plate of the stove by simply lifting it straight off of the stove body.

Figure 2.

Remove the perforated shipping strap sections of the screen frame mounting bracket as shown in grey.

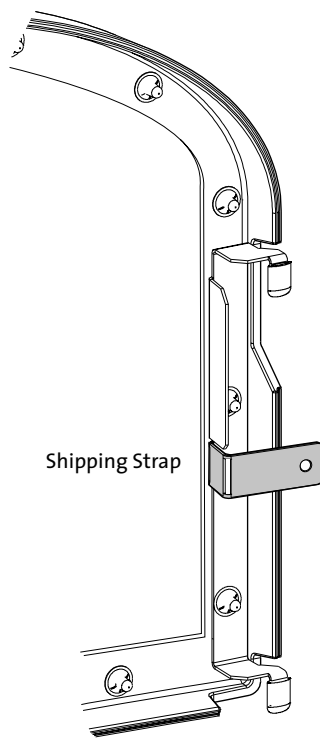

3. To open the firebox:
 - a) Remove four hex head screws using a 10 mm wrench and disengage the Top Convection Shroud from the top of the firebox. See fig. 2a.
 - b) Remove the Glass Frame by disengaging the two spring latches located on top of the firebox as in fig. 2a. Pull each handle forward to clear the latch from the notch in the frame and lift the frame straight up out of the stove.
4. Carefully remove the Top Plate Insert and Log Set package from the firebox.
5. **TO TAKE ADVANTAGE OF EASY ACCESS, INSTALL THE BLOWER BEFORE MOVING THE STOVE TO THE FINAL LOCATION.** See page 23.

Hardware Bag Contents

- Fuel Conversion Kit - LP157865
- Rock Wool, 1 oz.157259
- Top Plate Insert (for Rear Exit applications)

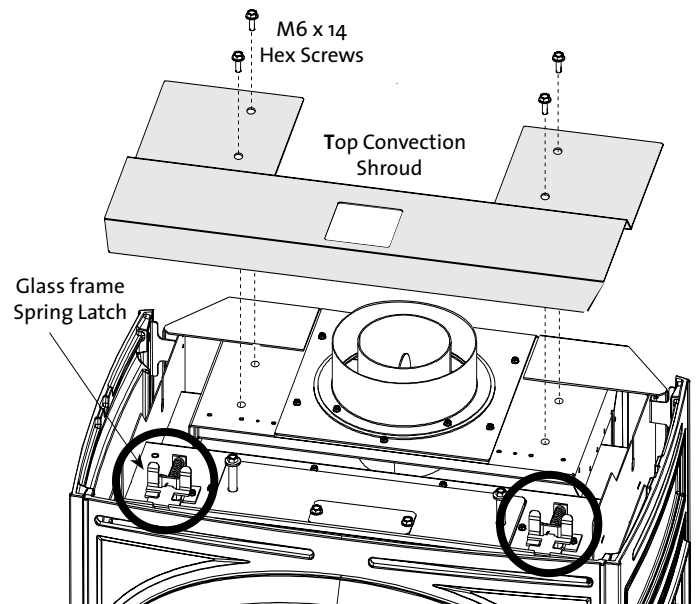

Figure 2a. Remove the Top Convection Shroud and disengage the glass frame latches.

Rear Exit Vent Conversion

This stove is built in the top exit vent configuration. Follow the procedure below to convert the Vent Adaptor for a rear exit installation.

1. Use a 1/4" nut driver to remove four inner screws from around the Vent Adaptor collar. See fig. 3. Remove five screws from around the top perimeter, and five additional screws from the rear perimeter. The vent adaptor will come away as an assembly.
2. Remove four screws on the rear exhaust cover plate and re-install the cover plate over the top outlet. Figs. 4 and 5.
3. Orient the vent adaptor outlet to the rear and secure the assembly using the screws removed previously. Fig. 6.
4. After the Top Convection Shroud and Top Plate have been replaced, position the cast iron Top Plate Insert (#7, Fig. 56) within the top plate outlet cut-out.

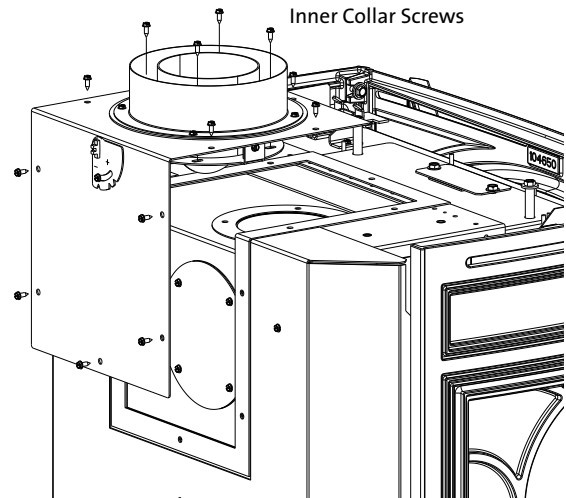

Figure 3.
Remove 4 inner collar screws and 10 perimeter screws to detach the Vent Adaptor from the firebox.

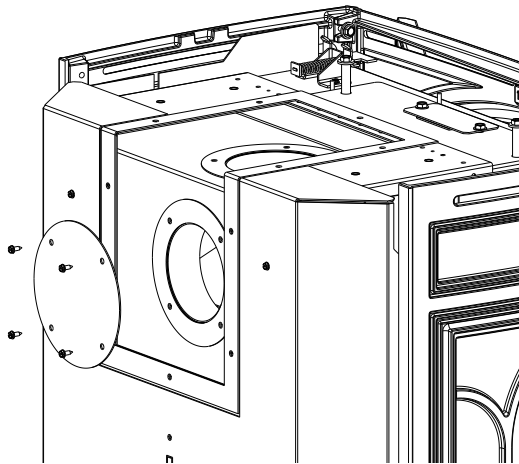

Figure 4. Remove cover plate from rear outlet.

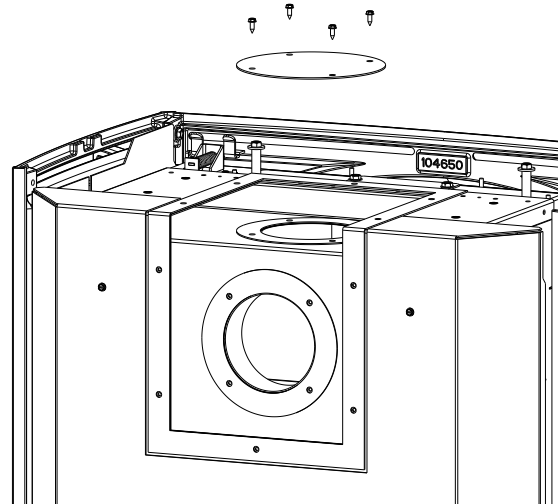

Figure 5. Install cover plate over top outlet.

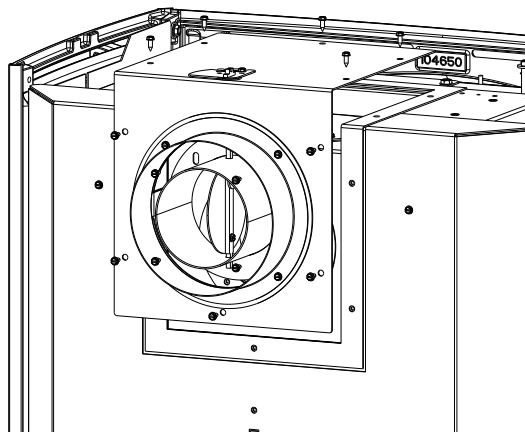

Figure 6. Rear exit orientation.

General Information

- **THIS HEATER MUST BE INSTALLED AND MAINTAINED BY A QUALIFIED SERVICE AGENCY.**
- The installation and repair of this appliance must be done by a qualified service person. Failure to properly install and maintain this heater could result in an unsafe or hazardous installation, which may result in a fire, explosion, property damage, personal injury or loss of life.
- This appliance should be inspected before use and at least annually. More frequent cleaning may be required due to excessive lint from carpeting, bedding material, etc. It is imperative that control compartments, burners, and circulating air passageways of the appliance be kept clean. See Maintenance, page 29, for details.
- **THIS APPLIANCE MUST NOT BE CONNECTED TO A CHIMNEY OR FLUE SERVING ANY OTHER APPLIANCE.**
- The installation must conform to local codes. Your local Jøtul dealer can assist you in determining what is required in your area for a safe and legal installation. Some areas require a permit to install a gas burning appliance. Always consult your local building inspector, or authority having jurisdiction, to determine what regulations apply in your area.
- **CODE COMPLIANCE :** Your local officials have final authority in determining if a proposed installation is acceptable. Any requirement that is requested by the local authority having jurisdiction, that is not specifically addressed in this manual, defaults to local code. In the absence of local codes, the installation requirements must comply with the current edition of National codes. In the U.S., these requirements are established in the National Fuel Code, ANSI Z223.1.(NFPA 54) current edition. In Canada, the codes have been established in CAN/CGA B149 Fuel Installation Code, current edition..
- **DO NOT OPERATE THIS STOVE IF ANY PART HAS BEEN UNDER WATER.** Call a qualified service technician to inspect the heater and to replace any part of the control system and any gas control which may have been under water.

Safety Information

- **Due to the high operating temperatures this appliance should be located out of traffic and away from furniture and draperies. Maintain proper clearance to combustible mantels and fireplace trim.**
- **Children and adults should be alerted to the hazards of high surface temperatures and should stay away to avoid burns or clothing ignition.**
- **Young children should be supervised while they are in the same room as the appliance. Toddlers, young children and others may be susceptible to accidental contact burns. A physical barrier, such as a child guard, is recommended to be used if there are at-risk individuals in the house. To restrict access to a fireplace or stove, install an adjustable safety gate to keep toddlers, young children and other at-risk individuals out of the room and away from hot surfaces.**
- **A barrier designed to reduce the risk of burns from the hot viewing glass is provided with this appliance and shall be installed for the protection of children and other at-risk individuals.**
- **If the barrier becomes damaged, the barrier shall be replaced with the manufacturer's barrier for this appliance. See fig. 56, page 31 for part numbers.**
- **Any safety screen, guard, or barrier removed for servicing an appliance must be replaced prior to operating the appliance.**
- **Clothing or other flammable materials should not be placed on or near the appliance.**
- **Never allow anyone to use the stove if they are unfamiliar with its operation.**
- **NEVER store or use gasoline or any other flammable vapors or liquids in the vicinity of this appliance.**
- **Never burn any solid materials (wood, cardboard, paper, coal, etc.) in this appliance. Use with natural gas or propane fuel ONLY.**
- **Do not slam or strike the glass panel.**
- **This appliance is NOT for use with aftermarket glass doors.**
- **Wear gloves and safety glasses while installing or performing maintenance procedures on this appliance.**

Installation Requirements

Location

In selecting a location for the stove, consider the following points:

- 1) Heat distribution
- 2) Vent termination requirements
- 3) Gas supply line routing
- 4) Traffic areas, furniture, draperies, etc.

The GF 500 DV may be located on or near conventional construction materials, however, proper clearance to combustibles must be maintained in order to provide adequate air circulation around the appliance. Also, it is important to provide adequate access around the stove for servicing and proper operation.

The clearance and hearth specifications listed in this manual are the minimum requirements for combustible material. A combustible material is anything that can burn (i.e. sheet rock, wall paper, wood, fabrics etc.). These surfaces are not limited to those that are visible and also include materials that may be located behind non-combustibles.

If you are not sure of the combustible nature of a material, consult your local fire officials. Remember, "Fire Resistant" materials are considered combustible: they are difficult to ignite, but will burn. Also, "fire-rated" sheet rock is considered combustible.

Floor Protection

This appliance CANNOT be installed directly on carpeting, vinyl, linoleum or wood laminate flooring, such as Pergo.

If this appliance will be installed on any combustible material OTHER THAN WOOD, a floor pad must be installed that is either metal, wood, ceramic tile, stone, or a listed hearth pad. This floor protection must extend the full width and depth of the appliance. It is not necessary to remove carpeting, vinyl or linoleum from underneath the floor protection. See fig. 7.

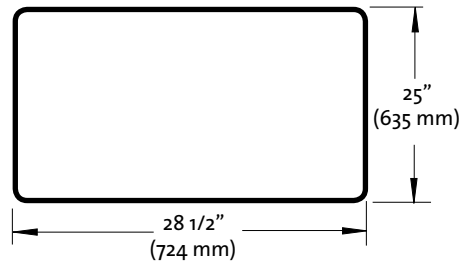

Figure 7. Minimum combustible floor protection.

Stove and Vent Clearance Requirements

The clearances specified and diagrammed here are established from the stove body. The safety barrier has no affect on clearances to combustible material.

Minimum Clearances from the Stove to Combustibles:

See figs. 8-12.

		Measured from:
Rear:	1 1/2" (38 mm)	Rear Shroud
Ceiling:	20.25" (514 mm)	Top Plate
Corner:	2" (51 mm)	Top Plate
Sides:	2" (51 mm)	Top Plate

Minimum Clearances between Vent Pipe and Combustible Materials:

Horizontal Run:

Off the top of the pipe	2" (51 mm)
Off the sides and bottom	1" (25 mm)

Vertical Run:

All sides	1" (25 mm)
-----------	------------

Alcove Installation

Maximum Alcove Depth:	24" (610 mm)
Minimum Alcove Width:	32 1/2" (826 mm)
Minimum Alcove Ceiling Height from floor:	50 1/4" (1276 mm)
with optional short legs:	48" (1219 mm)

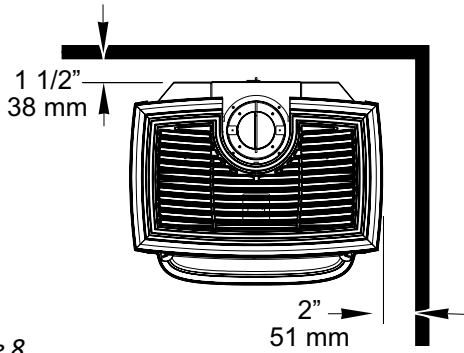

Figure 8.
Parallel Installation Clearances.

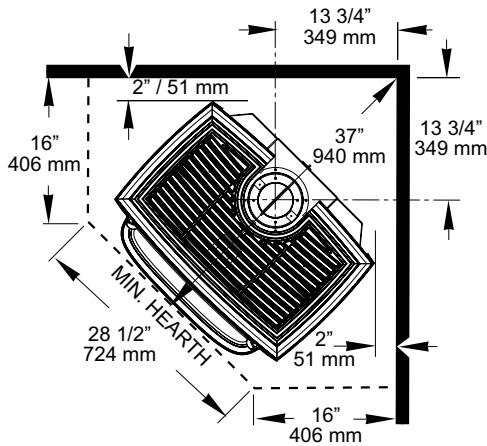

Figure 9.
Corner Installation clearances and minimum hearth pad.

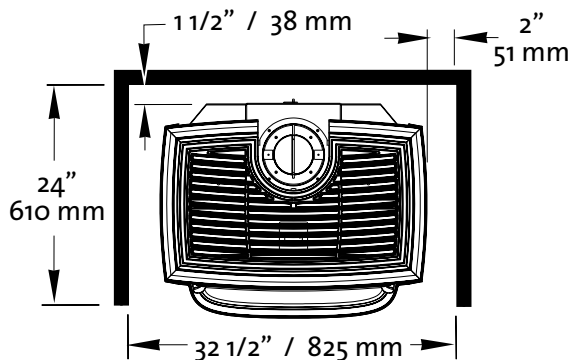
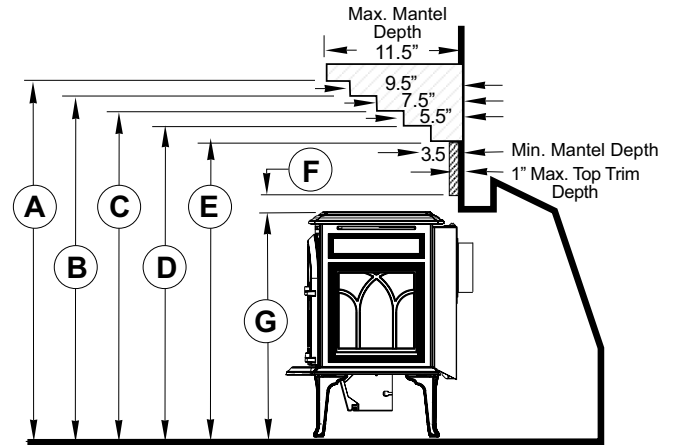
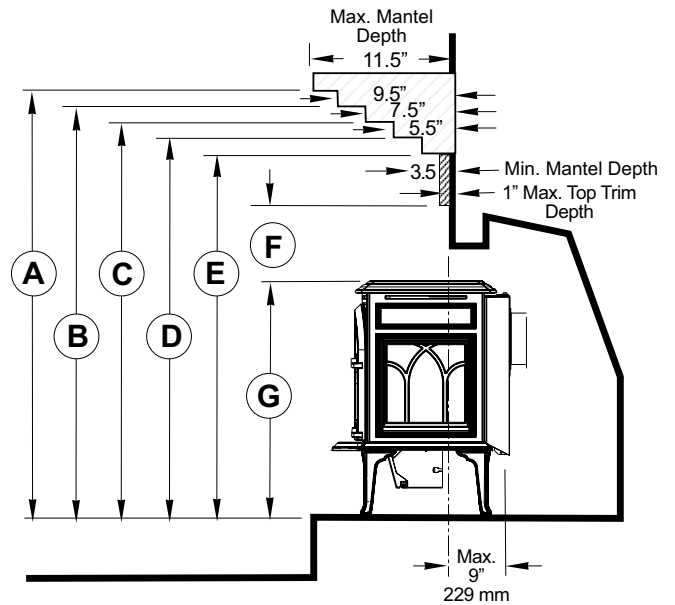

Figure 10.
Minimum Alcove Clearances.



- | | | | |
|---|----------------------|---|---------------------------------|
| A | 40 3/4 in. (1035 mm) | E | 34 3/4 in. (883 mm) |
| B | 39 1/4 in. (997 mm) | F | 3 1/4 in. (83 mm) |
| C | 37 3/4 in. (958 mm) | G | 30 in. (762 mm) |
| D | 36 1/4 in. (921 mm) | | Short Legs: 27 3/4 in. (705 mm) |

Figure 11.
Mantel Clearances - stove flush with fireplace face.



- | | | | |
|---|----------------------|---|---------------------------------|
| A | 54 1/2 in. (1384 mm) | E | 48 1/2 in. (1232 mm) |
| B | 53 in. (1346 mm) | F | 14 1/4 in. (362 mm) |
| C | 51 1/2 in. (1308 mm) | G | 30 in. (762 mm) |
| D | 50 in. (1270 mm) | | Short Legs: 27 3/4 in. (705 mm) |

Figure 12.
Mantel Clearances - stove recessed into fireplace, 9" max.

Venting Requirements

The Jøtul GF 500 DV gas stove may be installed with a vertical or horizontal termination and must conform to the configuration requirements described below.

This appliance is approved for use with vent systems from the following manufacturers:

- M&G DuraVent DirectVent Pro and GS Series
- American Metal Products (Amerivent)
- Security Chimneys International, Ltd. (Secure Vent)
- Selkirk Metalbestos (Direct Temp)
- Metal-Fab, Inc. (Direct Vent)
- Industrial Chimney Corp. (ExcelDirect)
- Bernard Dalsin Mfg. (Pro Form)

Use parts of one manufacturer only - DO NOT MIX VENT COMPONENTS FROM DIFFERENT MANUFACTURERS IN THE SAME SYSTEM.

Installation of any components not manufactured or approved by Jøtul or failure to meet all clearance requirements will void all warranties and could result in property damage, bodily injury, or serious fire.

The approved vent configurations described in this manual are derived from extensive testing under controlled laboratory conditions. Gas appliance performance can be negatively affected by variables present in the installation environment, i.e: atmospheric pressure, strong prevailing winds, adjacent structures and trees, snow accumulation, etc. These conditions should be taken into consideration by the installer and stove owner when planning the vent system design.

IMPORTANT

- **JOINT SEALING REQUIREMENT:** APPLY A 1/8" BEAD OF HIGH-TEMPERATURE SEALANT OR MIL-PAC® TO THE MALE SECTION OF THE INNER VENT PIPE. THE CEMENT SHOULD FORM A SEAL BETWEEN THE INNER AND OUTER PIPES.
- NEVER MODIFY ANY VENTING COMPONENT, OR USE ANY DAMAGED VENTING PRODUCT.
- THE GAS APPLIANCE AND VENT SYSTEM MUST BE VENTED DIRECTLY TO THE OUTSIDE OF THE BUILDING AND NEVER ATTACHED TO A CHIMNEY SERVING A SOLID FUEL OR GAS BURNING APPLIANCE. EACH DIRECT VENT GAS APPLIANCE MUST HAVE ITS OWN SEPARATE VENT SYSTEM. COMMON VENT SYSTEMS ARE PROHIBITED.
- IF VENTING SYSTEM IS DISASSEMBLED FOR ANY REASON, REINSTALL PER THE INSTRUCTIONS PROVIDED FOR THE INITIAL INSTALLATION.

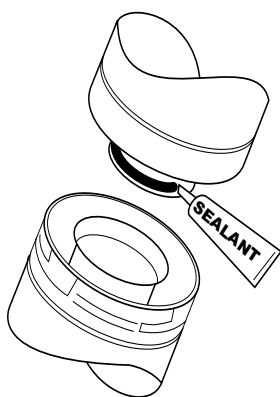

Figure 13.
DO NOT USE SILICONE SEALANT.

Vent Restriction

The GF 500 DV is equipped with an Exhaust Restrictor Plate which enables you to regulate the flow of exhaust gas. The plate prevents overly strong draft that can cause poor combustion and weak flame picture. **Follow the guidelines below, and on the following pages, to determine the correct restrictor plate setting for your particular installation configuration.**

Exhaust Restrictor

The Exhaust Restrictor is an adjustable plate located within the firebox exhaust outlet. It is adjusted by rotating the dial at the back of the stove within a range from the factory-set, fully open (no restriction) position to a fully restricted position. See Fig. 14. The Plus (+) and Minus (-) signs on the dial relate to degrees of restriction, from zero to approximately 70%. The three lettered positions correlate to the termination zones (A,B,C) diagrammed in figure 15. Use the diagram to determine the degree of restriction and shutter setting you should use.

Adjusting Exhaust Restrictor Plate:

1. Use the Vent Termination Matrix to determine which setting position to use. Vent rise and run is measured from the stove top to the first discharge opening of the exhaust vent cap.
2. Lift the Top Plate from the stove.
3. Locate the restrictor adjustment dial on the top of the exhaust outlet. Use a 1/4" nut driver to loosen the lock nut and pivot the dial to the position appropriate to your termination zone. See figs. 14 and 15.
4. Tighten the lock nut and replace the Top Plate.

Approved Horizontal and Vertical Vent Terminations

- **ALL VENTING MUST TERMINATE (END) WITHIN ONE OF THE DESIGNATED AREAS.**
- **SET STOVE EXHAUST RESTRICTOR TO THE POSITION THAT CORRESPONDS TO THE VENT TERMINATION AREA IN THE MATRIX.** When termination is exactly on a division line, use the less restrictive position. For example, if termination is 10 feet high and offset 7 feet, restriction should be set at Position B.
- **Up to four 45° or two 90° elbows are permitted in addition to the starter elbow, however, a 5 foot (1.52 m) reduction to the horizontal vent run must be made for each additional elbow, whether 45° or 90°.**

The circled letter designations in the vent matrix in figure 15 correspond to the Exhaust Restrictor dial settings on the stove. First, determine which vent termination zone is appropriate for your installation, then adjust the restrictor to the corresponding position as shown in figure 15.

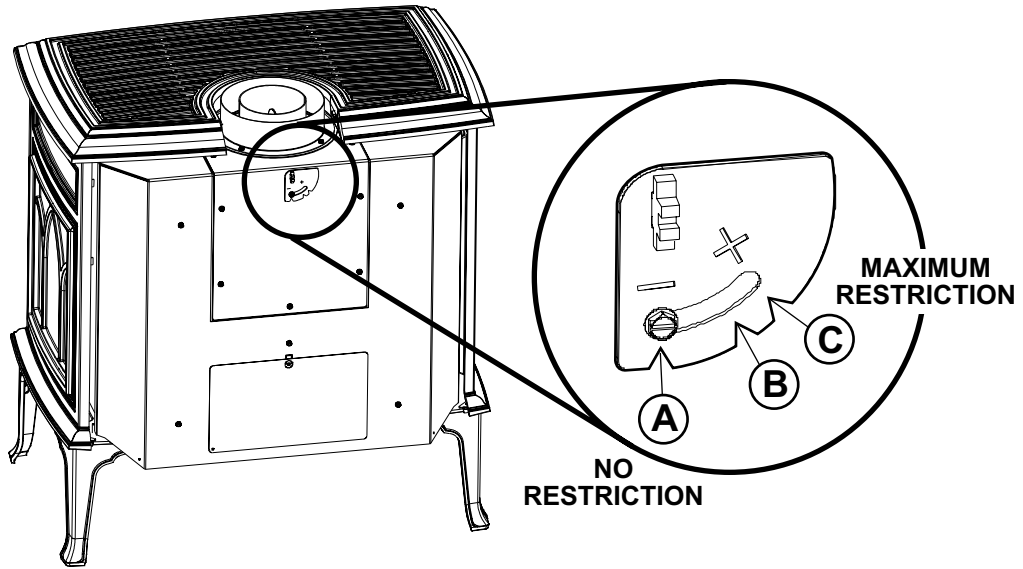

Figure 14. Use 1/4" socket driver to loosen the Exhaust Restrictor dial and adjust to the appropriate notch for your termination zone.

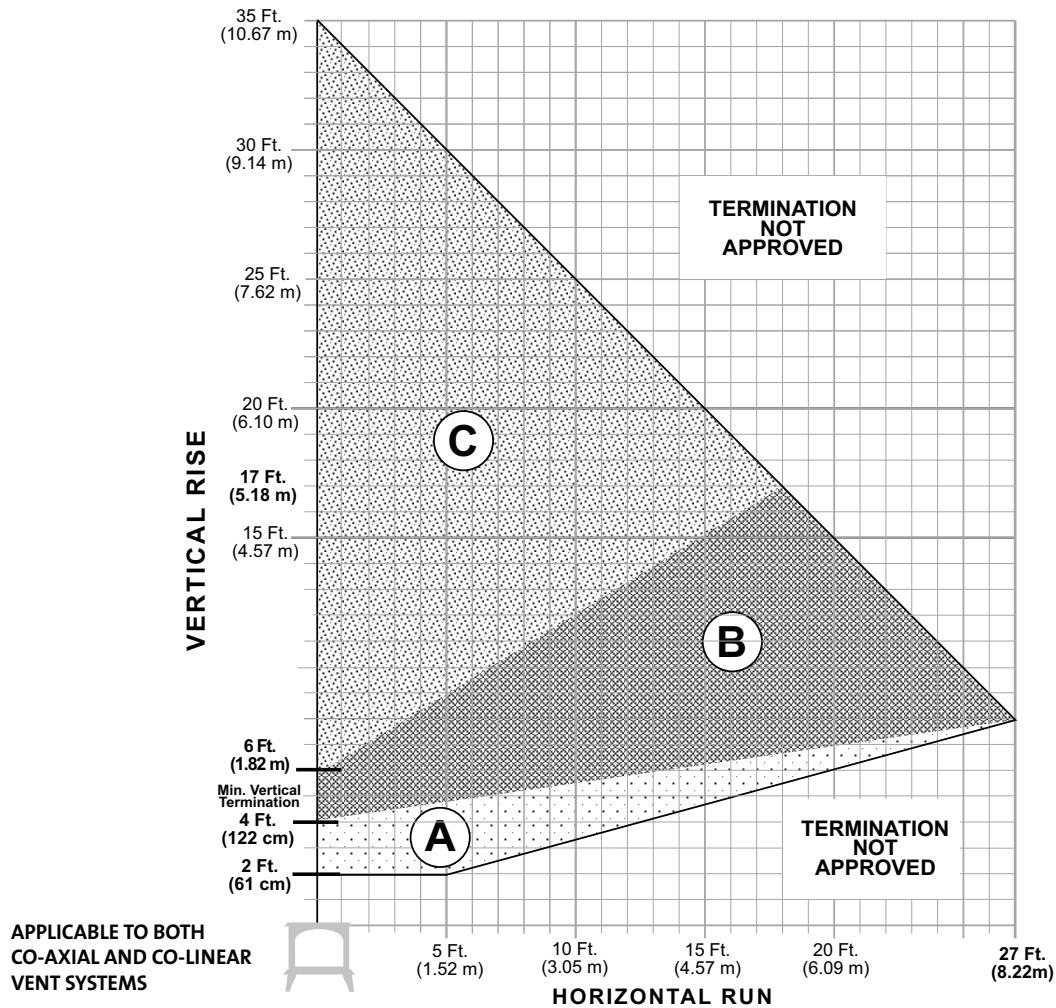

Figure 15. Vent Termination Zone Matrix - NG / LP

Vertical Vent Termination

The Jøtul GF 500 DV can be vertically vented through a ceiling or to a roof termination with the following guidelines:

- The termination should fall within the shaded areas of the grids depicted in the Vent Matrix, fig. 15, page 11.
- **Minimum Vertical termination must be no less than 4 ft.** (1.22 m).
- **Total rise must not exceed 35 ft.** (10.66 m).
- **Vent Terminus Clearance:** In no case shall any discharge opening on the cap be less than 18 in. (457 mm) vertically or horizontally from any roof surface or wall. See fig. 16.
- Steep roofs, nearby trees, and predominantly windy conditions can contribute to poor draft and/or promote draft reversal. Increasing the height of the vent may alleviate these conditions.
- Use Wall Straps to support an offset pipe run at intervals of three feet to avoid excessive stress on the offsets.
- A firestop is required at every floor. The floor opening should be framed to 10" X 10" inside dimension.
- Any venting that is exposed in living space above the first floor must be enclosed. Always maintain the required 1" clearance from all sides of the vertical vent system. Insulation in attic space must be retained by an insulation barrier.

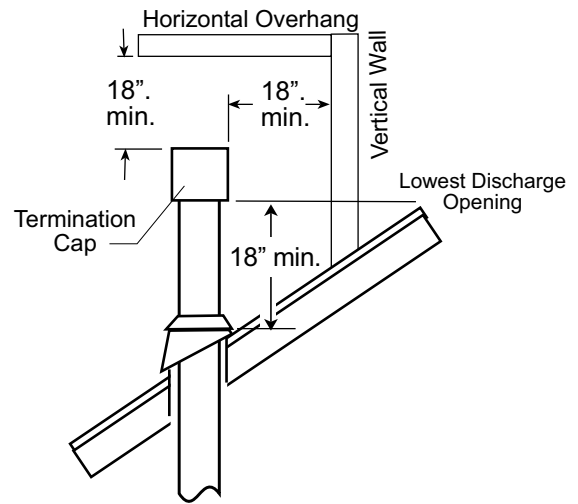

Figure 16.
Vertical vent termination height above roof.

Co-linear Vent Installation

The GF 500 DV may be vented through a masonry or Class A prefabricated chimney using a 3-inch diameter Co-linear Flexible Vent system approved for use with a solid-fuel burning fireplace. When installed in the manner described below, this system can improve the performance of the appliance in cold climate situations, as well as simplify the vent installation. See fig. 18.

Consult with the local code authority having jurisdiction before proceeding with this type of installation.

Refer to the vent manufacturer's instructions for specific installation procedures.

Follow these installation requirements:

- The chimney flue must be thoroughly cleaned and inspected by a qualified chimney service person.
- In a masonry chimney, a fireclay liner must be present the entire length of the chimney.
- Prefabricated chimneys must be UL 103 or ULC S-629 listed and have a minimum INSIDE diameter of 6 inches, (150 mm).
- No appliance may be installed into a chimney flue serving another appliance of any kind.
- THE AIR INTAKE FLEX PIPE MUST EXTEND 6 FEET BEYOND THE DAMPER AREA OF THE FIREPLACE.
- If the intake flex duct does not extend the full length of the chimney and connect to both the unit and the termination cap, A METAL BLOCK OFF PLATE MUST BE CONSTRUCTED AND INSTALLED ABOVE THE UNIT PRIOR TO THE END OF THE INTAKE FLEX AND MUST COMPLETELY SEAL THE CHIMNEY FLUE FROM THE ROOM.

If there is enough vent length and room in the flue, adding a return loop in the air intake run will help prevent draft reversals that can cause cold start problems.

WARNING: FAILURE TO POSITION THE PARTS AND STOVE IN ACCORDANCE WITH THESE DIAGRAMS OR FAILURE TO USE ONLY PARTS SPECIFICALLY APPROVED FOR USE WITH THIS APPLIANCE MAY RESULT IN PROPERTY DAMAGE OR PERSONAL INJURY. BE SURE TO MAINTAIN THE CLEARANCES TO COMBUSTIBLES SPECIFIED IN THIS MANUAL AND IN THE INSTRUCTIONS PROVIDED WITH EACH VENT COMPONENT.

Figure 17.
M&G DuraVent
#923GCL
Co-linear
Adaptor.

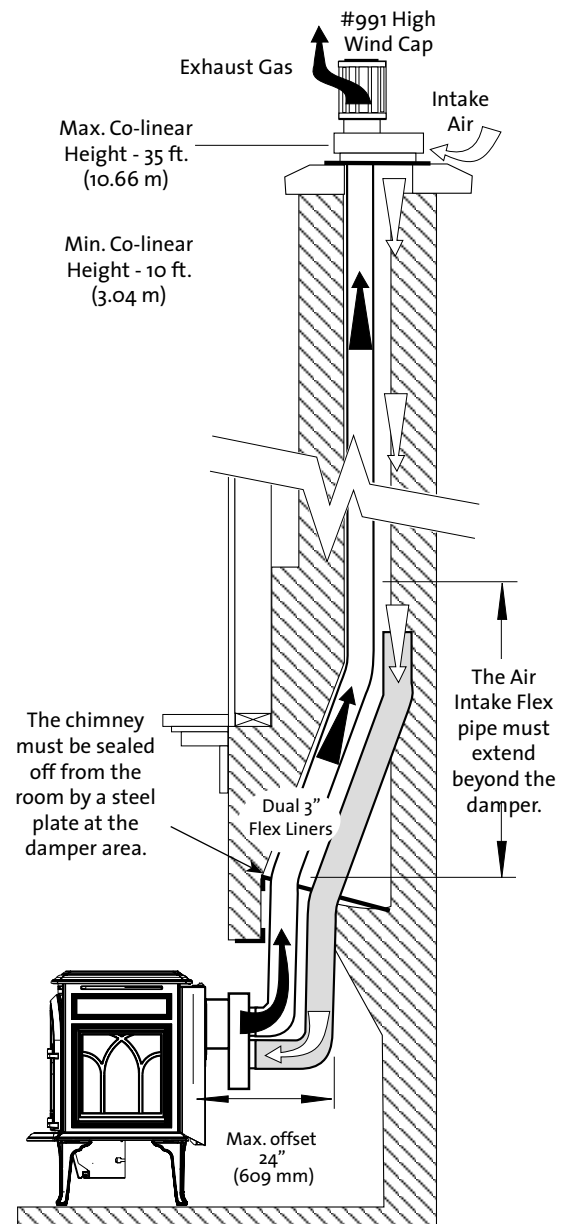
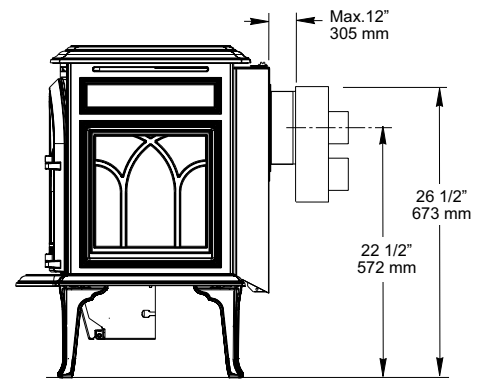

Figure 18. Co-linear Adaptor installed through a masonry chimney. M&G DuraVent components shown.

Masonry or Prefabricated Chimney Conversion

IMPORTANT NOTICE

IN THE U.S., THE USE OF AN EXISTING CHIMNEY AS AN AIR INTAKE IS NOT COVERED UNDER THE ANSI Z21.88-2014 / CSA 2.33-2014 TEST METHODS AND RESULTING ITS/WHI PRODUCT CERTIFICATION. THE CODE AUTHORITY HAVING JURISDICTION MUST BE CONSULTED PRIOR TO PROCEEDING WITH THIS INSTALLATION METHOD.

THIS INSTALLATION IS NOT APPROVED IN CANADA.

The GF 500 DV is approved for use with components of M&G DuraVent (Direct Vent Pro) coaxial Chimney Kit 46DVA-KMC and 46DVA-KCT in a masonry chimney or Chimney Kits 46DVA-KCA, 46DVA-KCB, and 46DVA-KCC for prefabricated solid fuel listed chimneys.

These installation requirements must be followed:

- Use the guidelines for vertical termination shown on page 12.
- In masonry chimney, a fireclay liner or listed steel liner, must be present the entire length of the chimney.
- Chimney height should not exceed 35 ft. (10.66 m).
- The liner must have an inside dimension of 6" round or greater.
- Prefabricated chimneys must be UL 103 or ULC S-629 listed and have a minimum INSIDE diameter of 6 inches, (150 mm). Prefabricated chimneys must be listed for the specific M&G Dura-Vent Chimney Conversion Kits noted above.

Horizontal Termination

- Any horizontal termination must fall within the shaded portion of the vent window matrix shown in fig. 15.
- **Horizontal termination requirements:**
 - 1) If no vertical run, the minimum horizontal run is 6 in. into a 36" Snorkel.
 - 2) If no vertical run, the maximum horizontal run is 24 in. into a 36" Snorkel.
 - 3) Maximum vertical run is 35 ft.
 - 4) With any vertical run, the maximum horizontal run is 27 ft.
- Up to four 45° or two 90° elbows may be used in addition to the starter elbow. **The maximum allowable horizontal run must be reduced by 5 feet (1.52 m) for each additional elbow, whether 45° or 90°.**

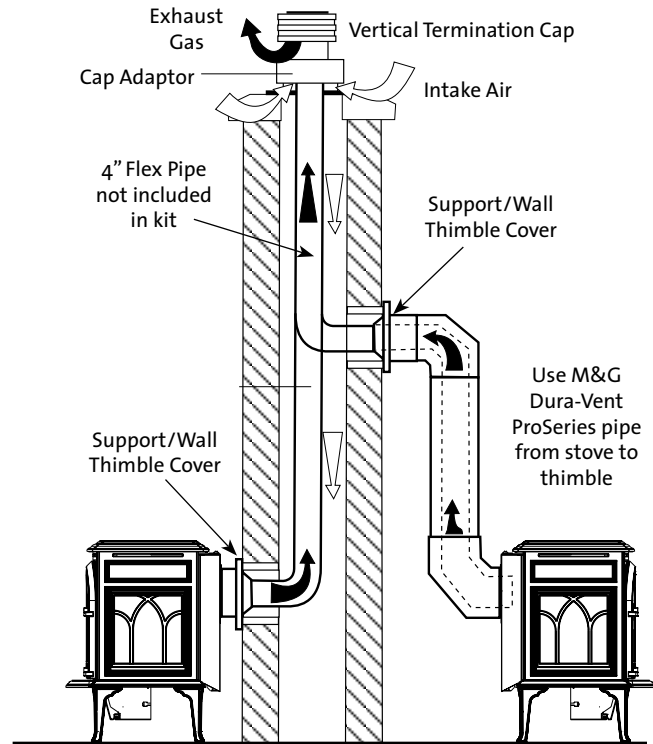

Figure 19. Vent System through a masonry chimney using the Simpson Dura-Vent Chimney Conversion Kits. Drawing is for illustrative purposes only - DO NOT VENT TWO APPLIANCES INTO A SINGLE CHIMNEY.

- The horizontal termination cap must maintain a 3" clearance to any overhead combustible projections 2 1/2" or less. It must also maintain 12" clearance from projections exceeding 2 1/2". See fig. 25.
- **Wall Cut-out Opening:** A minimum 10" X 10" (250 mm x 250 mm) square hole is required for proper pipe clearances through a combustible wall.
DO NOT FILL AIR SPACE WITH ANY TYPE OF INSULATION.
- **Any horizontal run of vent must be level or have a 1/4 in. rise for every foot of run toward the termination cap. NEVER ALLOW THE VENTING TO RUN DOWNWARD FROM STOVE TO TERMINATION; A DOWNWARD VENT RUN TRAPS HEAT AND CREATES A FIRE HAZARD.**
- Install a Vinyl Siding Standoff (M&G DirectVent Pro BVS) between the vent termination and an exterior wall covered by vinyl siding material to prevent potential heat damage to the siding.
- A direct vent horizontal terminal may not be recessed into a wall or siding. Install a Vinyl Siding Standoff on any irregular surfaced siding, (ie: ship lap, shake shingle) so that the termination cap is not imbedded into the siding.

Snorkel Termination

This appliance is approved only for 36 inch Snorkel termination. **Not approved for use with a 14 inch Snorkel.**

- The minimum horizontal run may be no less than 6" (152 mm).
- The maximum horizontal run may be no more than 24 in. (610 mm.)
- One 45° Elbow may be used for a corner installation as shown in fig. 23.
- **Exhaust Restriction:** Under normal circumstances, no exhaust restriction is recommended. Keep the factory setting (Position A - fully open).
- **Insulation Requirement:** Apply a minimum 1/2" thick foil-faced ceramic insulation blanket behind the Snorkel before attaching it to the wall (Jøtul PN 225606 is available).

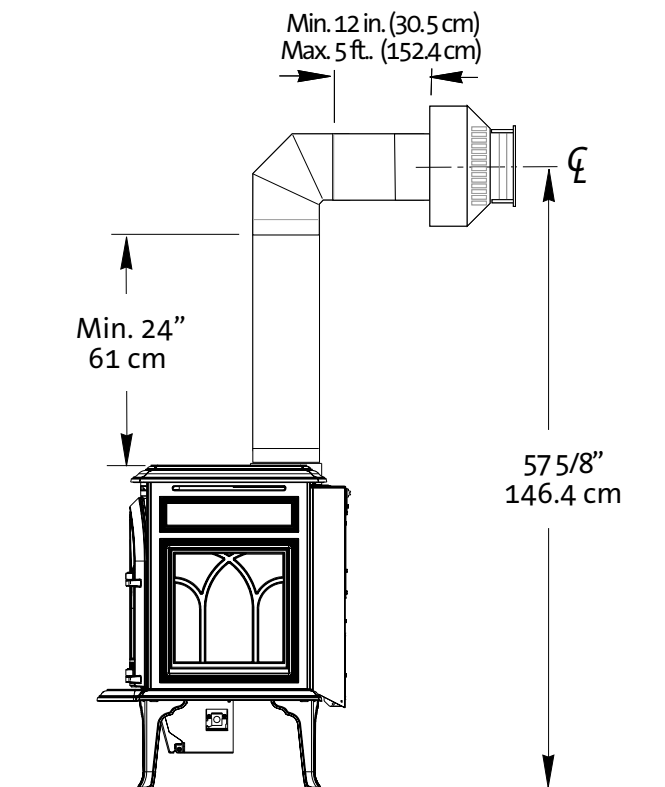

Figure 21. Min./Max. vent required for horizontal termination.

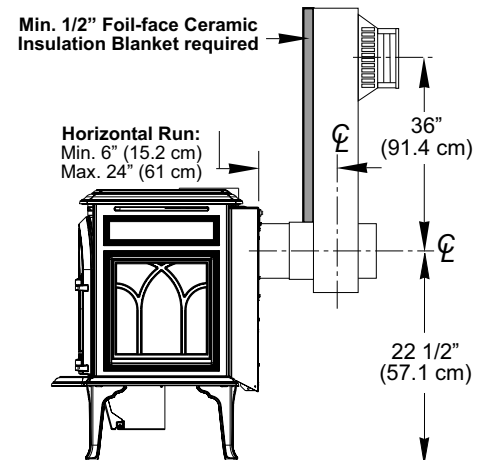

Figure 22.

Min./Max. horizontal and vertical vent run 36" Snorkel termination.

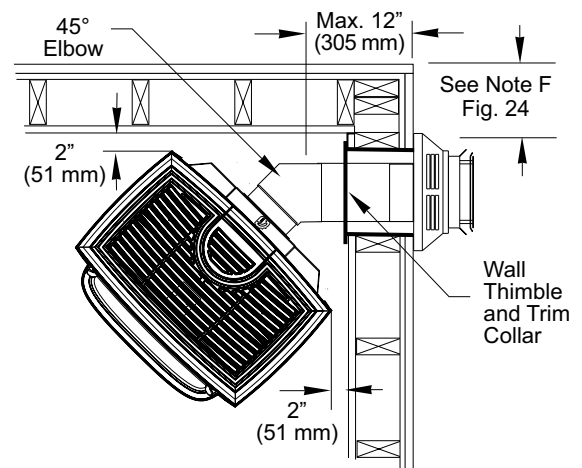

Figure 23.

Corner installation with 36" Snorkel termination. Maximum horizontal run is 12".

Horizontal Vent Termination Clearance

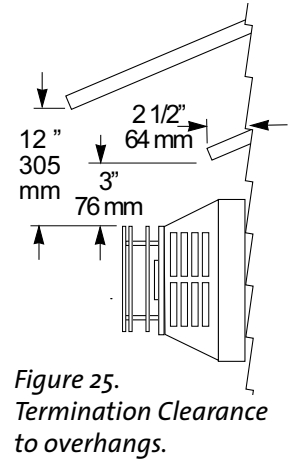
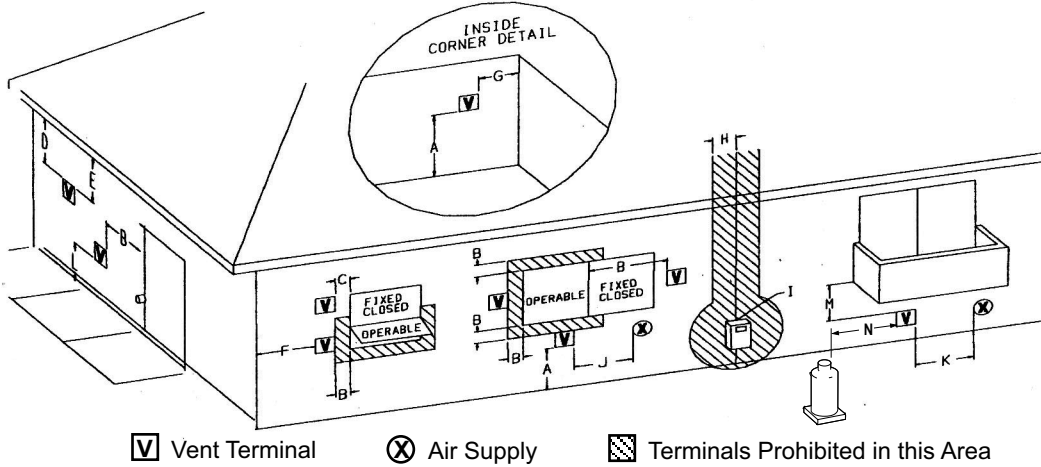

Figure 24. Horizontal Vent Terminal Clearances, Canada and United States

		Canadian Installations ¹	U.S. Installations ²
A	Clearance above grade, veranda, porch, deck, or balcony	12 in. (30.5 cm)	12 in. (30.5 cm)
B	Clearance to window or door that may be opened	12 in. (30.5 cm)	9 in. (23 cm) We recommend 12 in. to prevent condensation on a window.
C	Clearance to permanently closed window	12 in. (30.5 cm)	9 in. (23 cm) We recommend 12 in. to prevent condensation on a window.
D	Vertical clearance to ventilated soffit located above the terminal within a horizontal distance of 2 ft (60 cm) from the center line of the terminal	18 in. (46 cm)	18 in. (46 cm)
E	Clearance to unventilated soffit	12 in. (30.5 cm)	12 in. (30.5 cm)
F	Clearance to outside corner	12 in. (30.5 cm)	9 in. (23 cm) We strongly recommend 12 in. particularly where strong winds prevail.
G	Clearance to inside corner	12 in. (30.5 cm)	9 in. (23 cm) We strongly recommend 12 in. particularly where strong winds prevail.
H	Clearance to each side of center line extended above a gas meter or regulator	3 ft. (91 cm) within a height 15 ft. above the meter/regulator assembly	*
I	Clearance to service regulator vent outlet	3 ft. (91 cm)	*
J	Clearance to nonmechanical air supply inlet to building or the combustion air inlet to any other appliance	12 in. (30.5 cm))	9 in. (23 cm)
K	Clearance to a mechanical air supply inlet	6 ft. (1.83 m)	3 ft. (91 cm) above if within 10 ft. (3 m) horizontally
L	Clearance above paved sidewalk or paved driveway located on public property	7 ft. (2.13 m) ³	*
M	Clearance under veranda, porch, deck, or balcony	12 in. (30.5 cm) ⁴	12 in. (30.5 cm) ⁴
N	Clearance to propane tank relief valve and filler connection	5 ft. (1.52 m) ⁵ / 10 ft. (3.05 m) ⁶	5 ft. (1.52 m) ⁵ / 10 ft. (3.05 m) ⁶

1) In accordance with the current CSA B149.1, Natural Gas and Propane Installation Code.

2) In accordance with ANSI Z223.1/NFPA 54, National Fuel Gas Code

* For clearances not specified in ANSI Z223.1/NFPA 54 or CSA B149.1, the clearance will be in accordance with local installation codes and the requirements of the gas supplier.

3) A vent shall not terminate directly above a sidewalk or driveway which is located between two single family dwellings and serves both dwellings.

4) Permitted only if veranda, porch, deck, or balcony is fully open on a minimum of two sides beneath the floor.

5) Minimum clearance to tanks not filled on site.

6) Minimum clearance to tanks filled on site from bulk truck.

Fuel Conversion

The GF 500 DV gas stove is shipped from the factory equipped to burn NATURAL GAS only. If PROPANE gas is to be used as fuel, the appliance must first be converted by using Propane Conversion Kit 157865 included with the stove. Use Natural Gas Conversion Kit 157866 to change back for use with natural gas.

WARNING:

THE CONVERSION KIT IS TO BE INSTALLED BY AN AUTHORIZED JØTUL SERVICE TECHNICIAN IN ACCORDANCE WITH THE MANUFACTURER'S INSTRUCTION AND ALL CODES AND REQUIREMENTS OF THE AUTHORITY HAVING JURISDICTION. FAILURE TO FOLLOW THESE INSTRUCTIONS COULD RESULT IN SERIOUS INJURY OR PROPERTY DAMAGE. THE QUALIFIED AGENCY PERFORMING THIS WORK ASSUMES RESPONSIBILITY FOR THIS CONVERSION.

IN CANADA:

THE CONVERSION SHALL BE CARRIED OUT IN ACCORDANCE WITH THE REQUIREMENTS OF THE PROVINCIAL AUTHORITIES HAVING JURISDICTION AND IN ACCORDANCE WITH THE REQUIREMENTS OF THE CAN1-B149.1 AND .2 INSTALLATION CODE.

Tools required:

- 1/2" open ended wrench or deep-well socket,
- Torx T20 screw driver
- 1/4" socket driver or spade screwdriver
- 10 mm open-end wrench
- 4 mm hex key (included in kit)

Conversion Kit Contents:

- regulator tower labeled for either LP or NG (1)
- regulator tower screws (3)
- Left/Rear Burner orifice (1.40 mm - LP / 2.25 mm - NG)
- Right/Front Burner orifice (1.20 mm - LP / #47 - NG)
- Label A - to be completed and applied to the back of the stove
- Label B - apply to the stove's Rating Plate
- Small Fuel ID label - Apply to valve body (See fig.29).
- Pilot Orifice, (1) - #51 for NG / #30 for LP

Fuel Conversion Procedure

1. Turn off gas supply to stove.
2. Remove the stove Top Plate and Top Convection Shroud as in Fig. 2, page 5.
3. Disengage the two Glass Frame Latches and lift the glass panel frame up and out of the stove.
4. Remove both air shutter wing nuts, washers, and gaskets from the studs underneath the firebox. See fig. 26.
5. Lift the Brick Panel Support Shelves from the firebox floor to access and remove two #8x 1/2" sheet metal screws that secure the Burner Brackets to the floor. See figs. 27 and 56,
6. Grasp the burner at the large left and right through-ports and pull the assembly up and forward to disengage it from the burner injectors. Tilt the assembly to fit through the door opening. See fig. 27.

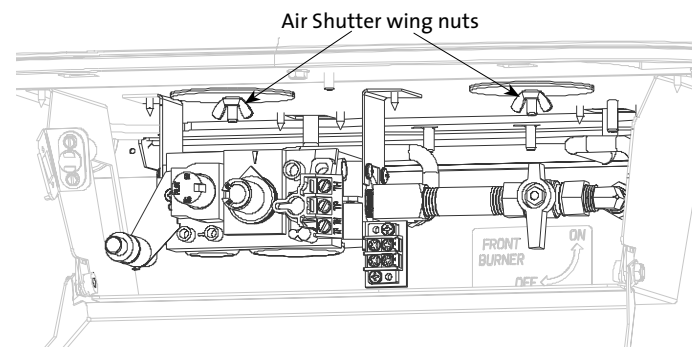

Figure 26. Air Shutter wing nuts are accessed from within the control compartment.

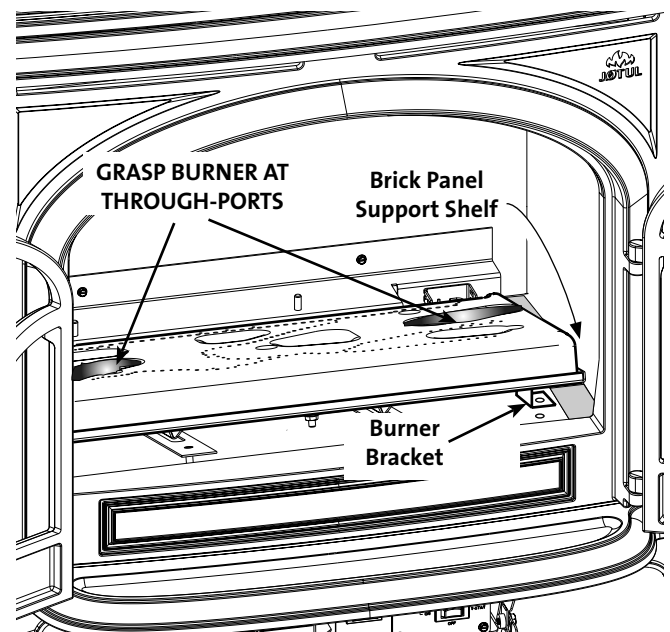

Figure 27. Pull the Burner assembly forward and up to disengage it from firebox.

- 7. CHANGE THE PILOT ORIFICE:** From within the firebox, remove the Pilot Head by pulling it straight up from the pilot base. See fig. 28.

Using the 4 mm allen wrench that is included with the conversion kit, unscrew the pilot orifice (counter-clockwise). Replace with the appropriate orifice:

- # 51 for natural gas
- #30 for propane gas

- 8. Change the Burner Injectors.** See fig. 30. Using a 1/2" open end wrench or deep-well socket remove both burner injectors from the brass elbow housings and replace with the appropriate injectors supplied in the kit. **Injectors are labelled: "L" = Left / "R" = Right.**

- 9. Baffle Conversion - Propane conversion only:** Remove two, 6 mm nuts to detach the steel baffle assembly from the firebox. See figs. 31 - 32.

Once the assembly is out, loosen two sheet metal screws to allow enough play for you to break off both extension wings of the Secondary Baffle at the perforations. See fig. 33.

Retighten those screws and re-install the modified baffle assembly back into the firebox. See fig. 34.

- 10. Replace the Burner.** Tilt the burner assembly downward to engage the shutters with both injector assemblies. Be sure the burner is pushed all the way back and resecure the burner brackets to the firebox floor with the original sheet metal screws. Replace the brick panel support shelves

- 11. Replace the Valve Regulator.** Using a Torx T-20 screwdriver, remove the screws from the front of the regulator. Remove the regulator components and replace with the one from the conversion kit. See fig. 29.

- 12. Install the identification labels** to the stove so that they can be seen by any person who may be servicing the stove.
 Label A: apply to back of stove
 Label B: apply to the rating plate attached to the back of the stove.
 Small Conversion Label: apply to valve.

- 13.** Reassemble the stove, apply gas to the system and check for leaks using a soapy water solution or digital gas detector.

NEVER USE AN OPEN FLAME TO CHECK FOR GAS LEAKS.

- 14.** Correct gas pressure is essential for efficient and safe operation of this appliance. Use a manometer to check pressures as specified in the Gas Pressure section of this manual (page 21).

- 15. Adjust the Air Shutters. Fig. 35**
 Replace the air shutter wingnuts and pull each air shutter forward (toward you) to the fully OPEN position, then adjust the inlet opening for the appropriate fuel: You will need to position the shutters to provide a gas/air mixture that will achieve the best flame picture with your particular installation.

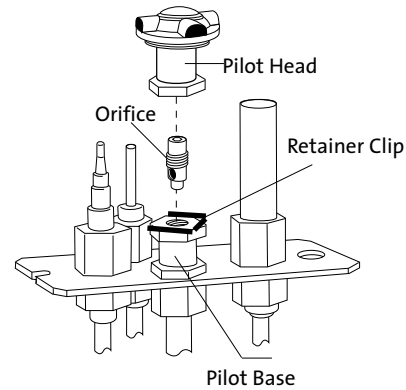

Figure 28. Pilot orifice removal and replacement.

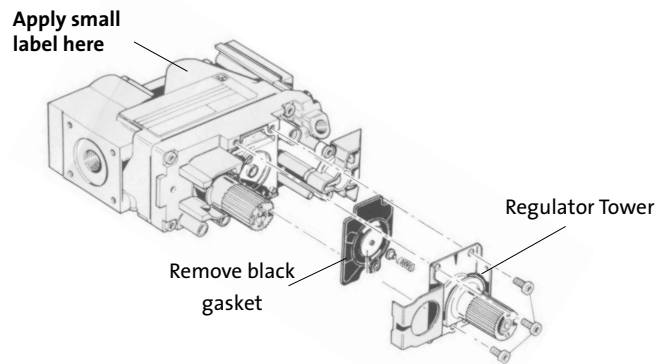

Figure 29. Regulator assembly.

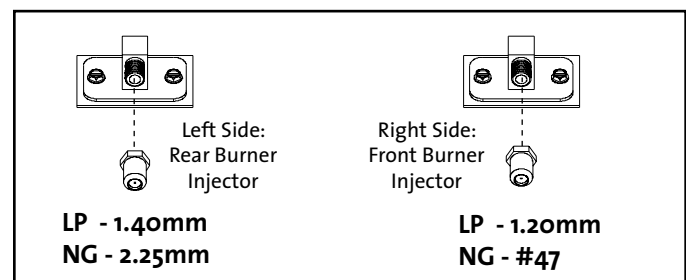

Figure 30. Change the burner injector orifices.

Pushing the stems back will restrict air, while pulling them forward (toward you) will open the shutter and increase air. With some experimentation, you will find the shutter position that works best for your installation. Start at the following positions for the appropriate fuel:

- Propane - 1/8" (3 mm) open
- Natural gas - 1/16" (1.5 mm) open

ALWAYS REFER TO THE LIGHTING INSTRUCTIONS ON THE INSIDE BACK COVER OF THIS MANUAL WHEN LIGHTING THE STOVE.

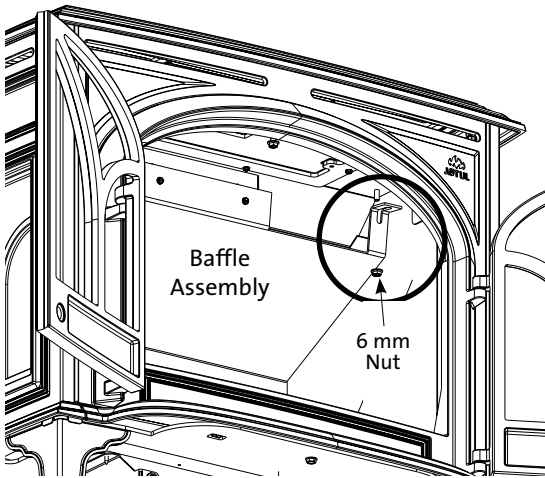

Figure 31.
Baffle Assembly location. Remove two 6 mm nuts to detach it from the firebox.

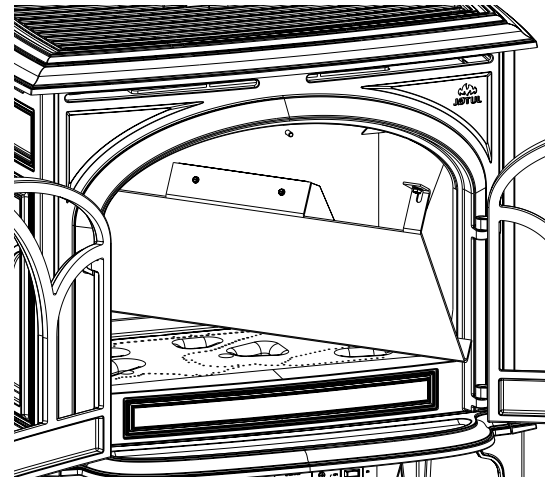

Figure 32.
Pull the baffle plate down slightly, then swing the end forward to remove it from the firebox..

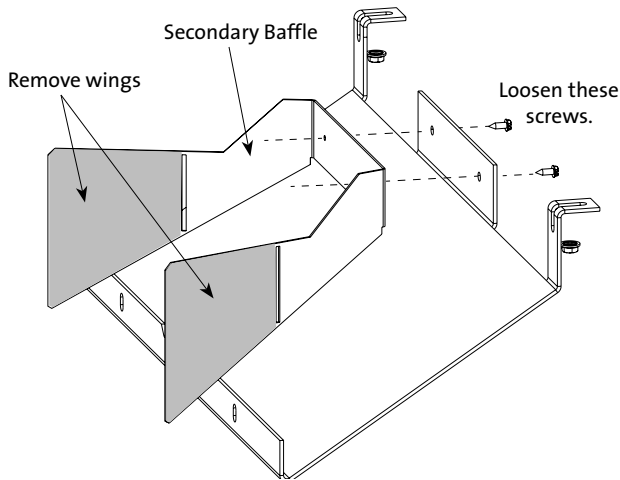

Figure 33.
Use pliers to break the end wings off the Secondary Baffle.

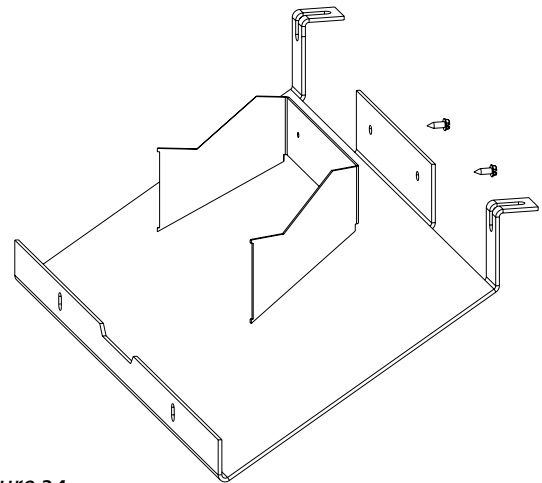

Figure 34.
Re-secure the modified Secondary Baffle.

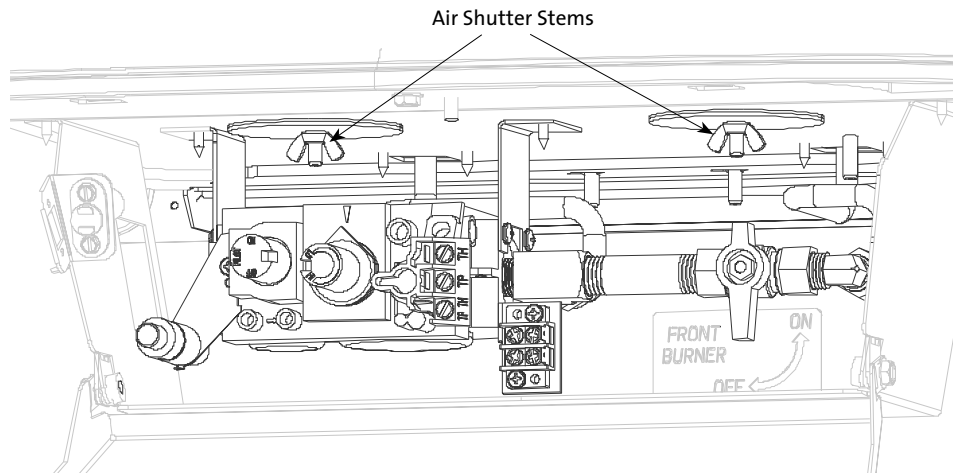

Figure 35.
Pull the shutter stems forward to increase primary air. Push back to restrict air.

Gas Supply Connection

NOTE: If appropriate, install the optional forced air blower before connecting the gas line, to prevent clearance interference between the two.

The gas supply line connection is made to the left side of the valve. The gas supply line should be 3/8" npt with a 1/2" diameter supply, or the appropriate size to provide sufficient gas pressure to the valve regardless of the input setting.

The use of Flexible Gas Appliance Connectors is acceptable in many areas in the U.S. However, Canadian methods vary depending on local code.

ALL INSTALLATIONS MUST COMPLY WITH LOCAL CODE OR IN THE ABSENCE OF LOCAL CODE, MUST COMPLY WITH THE MOST RECENT EDITION OF THE NATIONAL FUEL GAS CODE ANSI Z223.1/NFPA 54 OR THE NATURAL GAS AND PROPANE INSTALLATION CODE CSA/CAN-B149.

All codes require a gas shut-off valve (gas cock) and union, to be installed in the supply line, and in the same room as the appliance. This allows for the disconnection of the stove for servicing and maintenance. See fig. 36.

Secure all joints tightly using appropriate tools and sealing compounds. For propane units be sure to use compounds that are propane resistant. Turn on gas supply and test for gas leaks using a soapy water solution. Never use an open flame to check for leaks.

A T-HANDLE GAS COCK IS REQUIRED IN MASSACHUSETTS TO COMPLY WITH CODE 248CMR.

Leak test:

1. Mix a 50-50 solution of water and dish soap.
2. Light appliance- see lighting instructions on the inside back cover of this manual or on the stove's rating plate.
3. Brush or spray all joints and connections with the soapy water solution.
4. If bubbles appear at any connection or seam or a gas odor is detected, immediately turn gas control knob to the OFF position.
5. Tighten or reconnect the leaking joint and retest for any gas leaks.

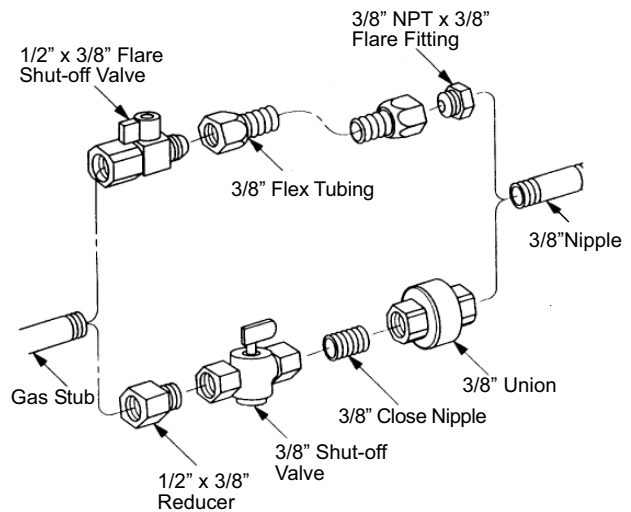

Figure 36. Supply valve connection fittings.

Gas Pressure

Correct gas pressure is essential for efficient and safe operation of the GF 500 DV gas stove. It is important that the correct pressure is established at the time of the installation. Proper gas pressure provides a consistent flow of gas to the appliance and is instrumental in checking for gas leaks.

Pressure Test: Attach a manometer to the appropriate test point on the valve. See fig. 37. The gauge connections are located on the front of the valve. Connections are identified by:

A - for Inlet or Supply Pressure (the amount of gas coming to the valve.)

B - for Manifold Pressure (the amount of gas that is coming out of the valve to the burner.)

ALWAYS TEST PRESSURES WITH VALVE REGULATOR CONTROL KNOB SET ON "HIGH".

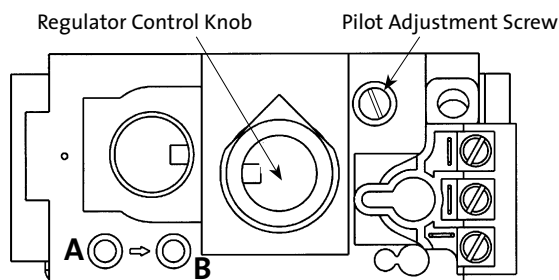

Figure 37.
Pressure test points, regulator control and pilot adjustment.

INLET GAS PRESSURES (inches water column)

	MIN	MAX
NATURAL GAS	5.0	7.0
PROPANE	12.0	14.0

The appliance and its appliance main gas valve must be disconnected from the gas supply piping system during any pressure testing on that system at test pressures in excess of 1/2 psig (3.5 kPa).

The appliance must be isolated from the gas supply line by closing its individual manual gas shut-off valve (gas cock) during any pressure testing of the gas supply piping system that is equal to or less than 1/2 psig (3.5 kPa).

MANIFOLD PRESSURES (inches water column)

	MIN	MAX
NATURAL GAS	1.2	3.8
PROPANE	2.9	11.0

High Altitude Adjustment

The decreased atmospheric pressure of higher altitudes affects heat value of gaseous fuels. Most gas suppliers derate the gas intended for use at elevations above 2000 feet. Check with your gas supplier before performing derate adjustment to the burner. If the gas supplier does not derate fuels, install High Altitude Adjustment Kit 157695 for Propane and Kit 157696 for Natural gas.

U.S. & Canada per

ANSI Z21.88-2014 • CSA 2.33-2014, CAN/CGA 2.17

Orifice Sizes for 610-1370 meters (2000-4500 ft.):

Natural Gas: Right/Front - #44 Left / Rear - #48

Propane: Right/Front - 1.35 mm Left / Rear - 1.15 mm

See data on the stove rating plate for additional information. At higher altitudes, consult the local gas distributor or the authority having jurisdiction for proper rating methods. If the installer must convert the unit to adjust for varying altitudes, the information label must be filled out and applied to the appliance at the time of the conversion.

Derating Procedure

- Follow the steps for Burner Injector replacement in the Fuel Conversion procedure on pages 17-18. Use the injectors supplied with the adjustment kit. Detailed instructions are also included in the kit.
- Conduct gas leak and gas pressure tests as detailed the preceding section of this manual.
- Conduct system check and flame picture adjustments as specified on pages 26-27.

INSTALLER: Fill out the appropriate information and apply the high altitude conversion label provided to the rating plate on the appliance. See fig. 38.

This appliance has been converted for use at an altitude of _____.	
Orifice Size: _____	Manifold Press. _____
Input Btu/Hr. _____	Fuel Type _____
Date: ___/___/___	Converted by: _____
Cet appareil a été converti au pour utilisation à une altitude de _____.	
Taille d'orifice(s) _____	
Pression au manifold _____	Type de gaz _____
Date: ___/___/___	Converti par: _____

Figure 38. High Altitude Conversion Label.

Accessories

Optional Wall Thermostat 750003

Use only a 750 millivolt DC two-wire circuit wall thermostat with this appliance. The thermostat should be placed in the same room as the heater, typically 5 feet off the floor. Avoid drafty areas or any area that may affect the accuracy of the thermostat.

The thermostat should be connected to the terminal block using a minimum of 16 gauge wire with a maximum length of 25 feet of wire.

Connect either of the two thermostat wire leads to either of two terminals on the terminal block located to the right of the main gas valve. Do not overtighten the connections. **IT IS NOT NECESSARY TO DISCONNECT ANY OTHER WIRES.** See Fig. 39.

For thermostatic operation, the On/Off/T-Stat switch on the back of the stove must be in the T-stat position, and the pilot light must be running, as it is the power source for the thermostat.

At the thermostat, the two wires should be connected to the two connection screws on the thermostat base plate per the manufacturer's instructions.

Optional Remote Control 224910

When using a remote, the remote receiver should be wired to the terminal block in the same way the as the thermostat. See the instructions above.

Follow the operating instructions included with the Remote Control unit.

CAUTION:

LABEL ALL WIRES PRIOR TO DISCONNECTION WHEN SERVICING THE CONTROLS. WIRING ERRORS CAN CAUSE IMPROPER OR DANGEROUS OPERATION. ALWAYS VERIFY PROPER OPERATION AFTER SERVICING THE APPLIANCE.

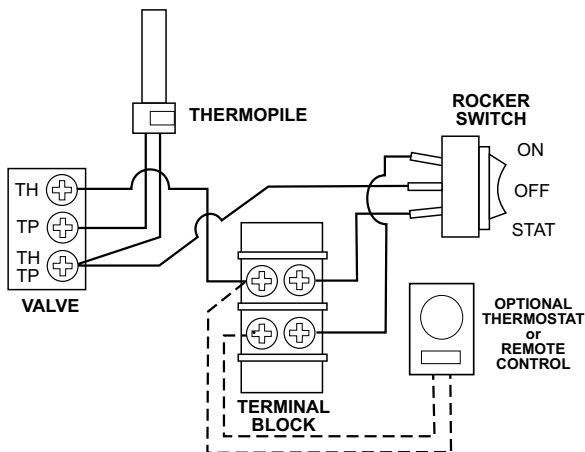

Figure 39. Accessory wiring diagram.

Optional Double-sided Brick Panel Kit 157697

1. Locate the retainer tabs in the upper corner of each side of the firebox. Bend each retainer tab out enough to engage the side brick panels. See fig. 40.
2. Install the Lower Panel, (the smaller of the two rectangular panels.)
Position it up against the back wall, resting on the rear shelf.
3. Set the Upper Panel on the Lower Panel. Hold those panels in place while setting one Side Panel on the shelf beside the burner and under its retainer tab. Bend the retainer down to fully engage the side panel.
4. Engage the opposite matching Side Panel under its retainer tab and seat it against the wall. Bend that retainer tab down to secure the panel in place.

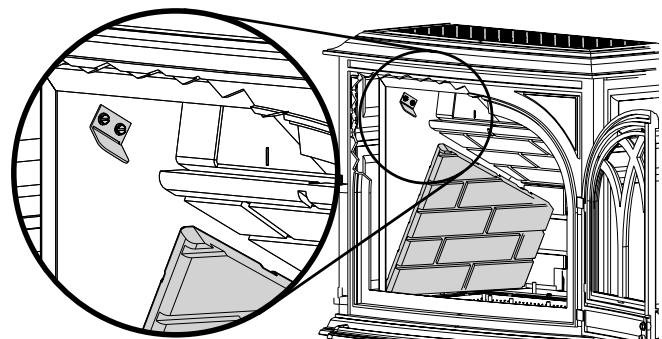
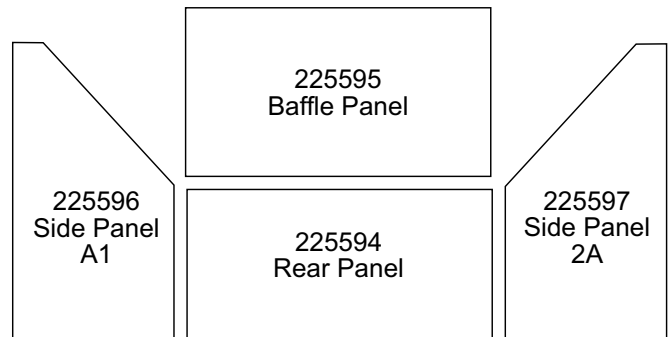

Figure 40. Install the Brick Panels.

Optional Variable Speed Blower Kit 156000

- THIS BLOWER MUST BE ELECTRICALLY GROUNDED IN ACCORDANCE WITH LOCAL CODES OR, IN THE ABSENCE OF LOCAL CODES, WITH THE CURRENT ANSI/NFPA 70, NATIONAL ELECTRICAL CODE OR CSA C22.1- CANADIAN ELECTRICAL CODE.
- THIS UNIT IS SUPPLIED WITH A THREE-PRONG (GROUNDING) PLUG FOR PROTECTION AGAINST SHOCK HAZARD AND SHOULD BE PLUGGED DIRECTLY INTO A PROPERLY GROUNDED THREE-PRONG RECEPTACLE. DO NOT CUT OR REMOVE THE GROUNDING PRONG FROM THE PLUG.
- ALWAYS DISCONNECT THE POWER SUPPLY WHEN PERFORMING ANY SERVICE ON THE APPLIANCE.

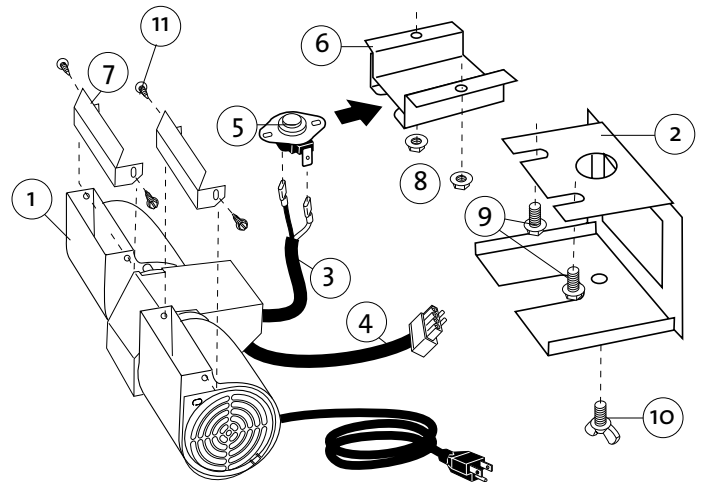

Figure 41. Blower Kit Components

Connect the gas supply line to the stove, before installing the Blower.

Use a 90° elbow off the control valve to create clearance required for the blower installation.

1. Unpack and check the contents of the blower kit. Contact your dealer if damage is evident or parts are missing. See fig. 41.
2. Attach the Snapstat Bracket to the studs located in the middle of the firebox floor using the two M6 hex nuts and a 10 mm wrench. See fig. 42.
3. Attach the Blower Bracket to the stove using the two M6 flange head hex bolts as shown in fig. 42.
4. Install the Blower with the duct openings oriented to the rear. See fig. 43. Feed the both wire harnesses through the bracket opening and secure the blower to the bracket with the wing screw.
5. Attach either Snapstat wire connector to either Snapstat terminal. See fig. 43.
6. Install the Snapstat by sliding it all the way into the slot in the bottom of the Snapstat Bracket as shown in figs. 42 and 43.
7. Connect the male wire harness connector to the female wire harness connector already installed in the stove. See fig. 43.
8. Connect the blower power cord to the nearest outlet.

Contents	Tools Required
1. Blower	• 10 mm wrench
2. Blower Bracket	• short phillips screwdriver
3. Snapstat Wire Harness	• safety glasses
4. Control Switch Wire Harness	• work gloves
5. Snapstat	
6. Snapstat Bracket	
7. Blower Duct Deflector (2) - <i>Not used on GF 500 DV</i>	
8. M6 Hex Head Flange Nuts (2)	
9. M6 x 12 Hex Head Flange Screws (2)	
10. M6 x 12 Wingscrew	
11. #8 x 1/2" phillips screw (2)	

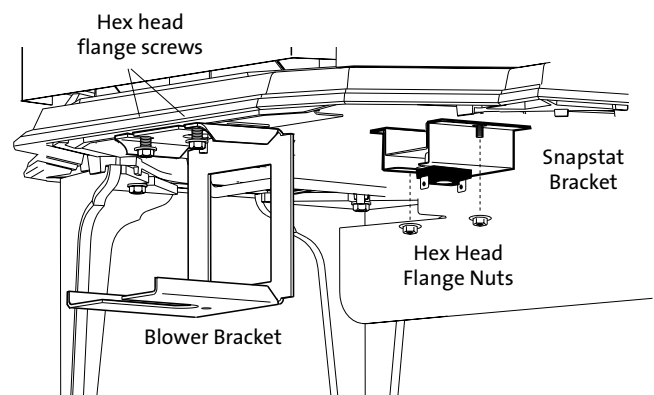
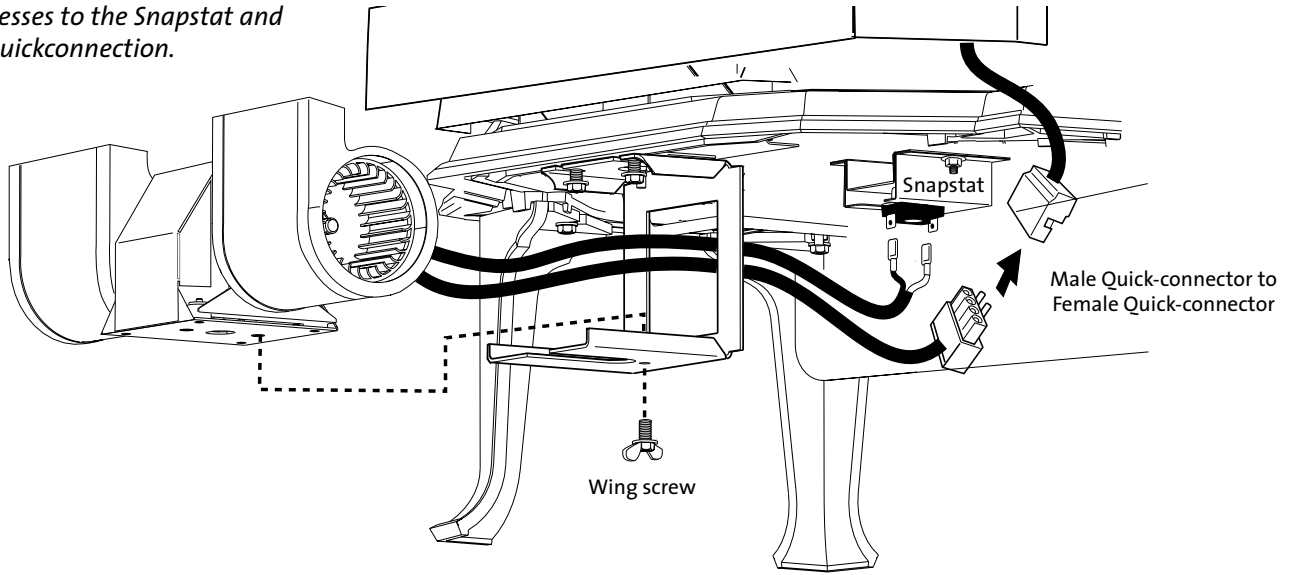

Figure 42. Attach Snapstat and Blower Brackets.

Figure 43. Attach Blower to the Mounting Bracket with the wing screw and connect wire harnesses to the Snapstat and controls quickconnection.



Blower Operation

The optional variable-speed blower will enhance heat circulation around the firebox and out into the room. The blower is controlled by a heat activated switch (snapstat) that will ONLY function when the control switch is in AUTO setting. After the fire has been burning for a time, the snapstat will react to the heat and activate the blower. Fan speed may be manually adjusted using the control knob. If the burner turns off, the blower will be shut off automatically when the stove cools down.

If automatic blower circulation is not desired, place the blower control switch in the MANUAL position.

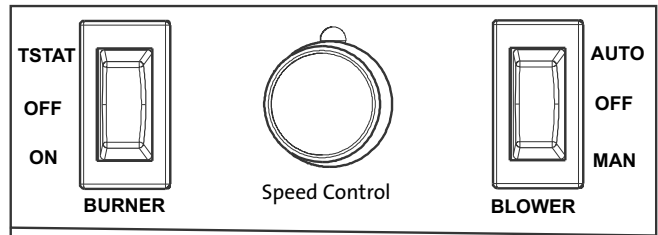

Figure 44. Blower Controls

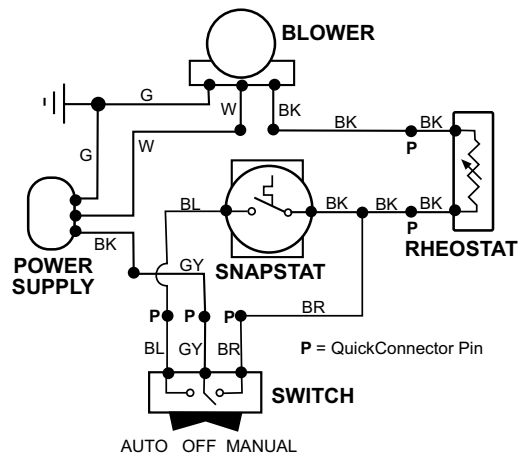

Figure 45. Blower Wiring Diagram

Log Set Installation

The GF 500 DV log set must be installed before operating the burner. The log set includes six log pieces, packaged inside the firebox. Place the logs on the burner in order as numbered in figs. 46-47. Mate holes in the underside of logs with pins or nubs on the adjoining parts.

#157706 Log Set Identification

Install the logs in this order:

- #1 Rear Log
- #2 Lower Left Log
- #3 Lower Right Log
- #4 Upper Left Log
- #5 Upper Right Log
- #6 Small Front Log

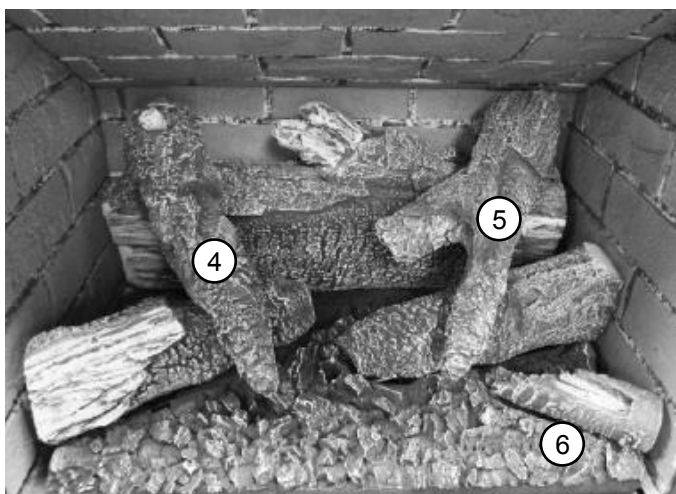
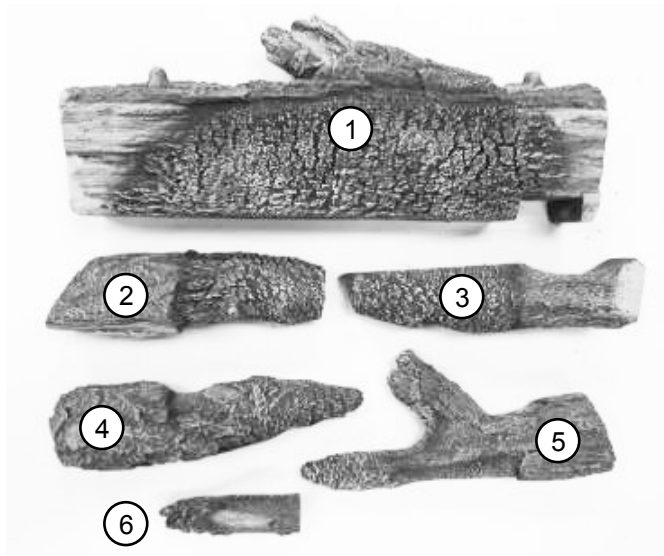

Figure 46. Set the Upper Left, Upper Right, Front logs into place.

A quantity of ember stones is included with the log set. **THE EMBERS ARE ONLY INTENDED TO BE USED AS FILLER ON THE STEEL SHELVES AT EACH SIDE OF THE BURNER IF THE OPTIONAL BRICK PANELS ARE NOT INSTALLED. DO NOT PLACE EMBERS ON THE BURNER BASE ITSELF.**

A quantity of rock wool is included as an enhancement to replicate glowing embers. Use a toothbrush or tweezers to **sparingly** place pinches of rock wool on the front of the burner base.

DO NOT PLACE ROCK WOOL OVER BURNER PORTS. DO NOT USE THE ENTIRE QUANTITY OF ROCK WOOL. BE SURE TO KEEP THE PILOT CARRY-OVER PORTS CLEAR OF OBSTRUCTIONS. SEE FIG. 47.

WEAR GLOVES AND HANDLE THE LOG PARTS CAREFULLY.

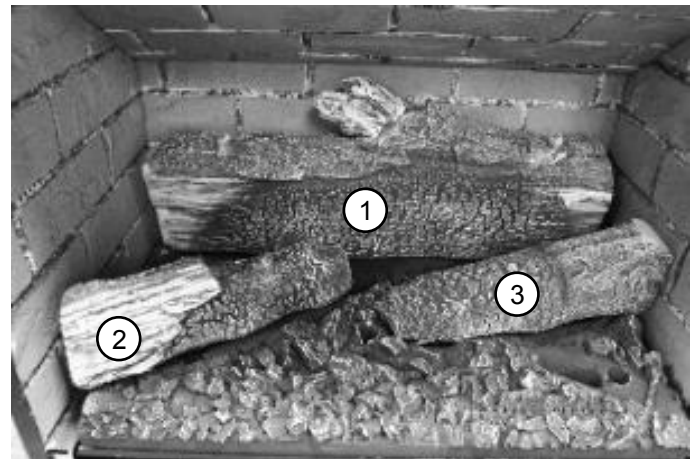

Figure 47. Set the Rear, Lower Left, and Lower Right logs onto the burner base as shown.



Figure 48. Use caution in placing the logs to ensure that the pilot carry-over ports are not obstructed.

System Check

1. **PURGING THE GAS LINE:** When lighting the appliance for the first time, it will take a few moments to clear the gas line of air. Once this purge is complete, the appliance will operate as described in the lighting instructions. From a cold start, it may be helpful to let the pilot light burn for 10 - 15 minutes to establish positive draft, before turning the burner on. See the procedure on the inside back cover of this manual. Subsequent burner starts will not require purging the gas line unless the supply line is shut off.
2. **PILOT FLAME:** You can monitor the pilot flame behind the burner in the cut-out under the rear log. See fig. 48, pg. 25. The pilot flame should be steady - not lifting or floating. The flame should be blue in color around the pilot hood, with traces of yellow toward the outer edges.
The pilot flame should engulf the thermocouple and thermopile and project from the pilot hood forward to the burner carry-over ports. Adjust pilot flame intensity using the adjustment screw located to the right of the valve regulator knob. See fig. 49.
3. **MANUAL BURNER ADJUSTMENT:** This stove is equipped with a variable gas control valve that allows manual adjustment of the flame height and heat output. To adjust the flame intensity, rotate the regulator knob.

Flame height will adjust approximately 50% between the LOW and HIGH settings.

NO SMOKE OR SOOT SHOULD BE PRESENT. CHECK LOG PLACEMENT IF SOOT OR SMOKE IS PRESENT. IF SOOT OR SMOKE PERSISTS, THE AIR SHUTTER(S) MAY NEED TO BE ADJUSTED.

See Flame Appearance / Air Shutter for air shutter settings and adjustments on the next page. Note: The more offsets there are in the vent system, the greater the need for an air shutter adjustment.

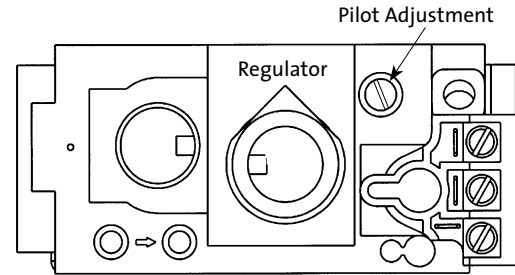

Figure 49. Pilot adjustment at the valve.

WARNING:

AIR SHUTTER ADJUSTMENTS SHOULD ONLY BE PERFORMED BY A QUALIFIED, PROFESSIONAL SERVICE TECHNICIAN.

Flame Appearance / Air Shutter Adjustment

The GF 500 DV gas stove is shipped from the factory equipped to burn Natural gas and the air inlet shutters have been set to provide optimal combustion efficiency under a variety of venting configurations. The air shutters may be adjusted, however, to accommodate the conditions of your individual installation and to provide the best flame picture. Other installation related variables can also affect the flame picture.

Too large an air setting - the appliance will generate a flame that is blue and transparent, or an “anemic” flame.

Too small an air setting - the appliance will generate very long yellow flames resulting in soot. Sooting produces black deposits on the logs, on the inside walls of the appliance, and potentially on the exterior termination cap. Sooting is caused by incomplete combustion in the flames and lack of combustion air entering the air shutter opening.

WARNING: AIR SHUTTER ADJUSTMENTS SHOULD ONLY BE PERFORMED BY A QUALIFIED PROFESSIONAL SERVICE TECHNICIAN.

To adjust the air shutters:

1. Reach under the stove and loosen the Air Shutter wing nuts. The RIGHT shutter controls the REAR Burner. The LEFT shutter controls the FRONT Burner. See fig. 50. Slide the wing nut stems forward toward yourself to open the air shutters and back to provide less air. Before making any adjustments, start at the factory shutter settings:
 - Natural Gas - open 1/16” (1,5 mm)
 - Propane - open 1/8” (3 mm)
2. Allow the stove to settle into a steady state by burning for 20-30 minutes on the HIGH setting, observing the flame continuously. If the flame appears weak, slow, or sooty, increase the air shutter opening in 1/16” increments until the desired flame picture is achieved. After each small adjustment, allow the burner to settle in again before making further adjustment.
3. Tighten the wing nuts to secure each shutter at the desired setting.

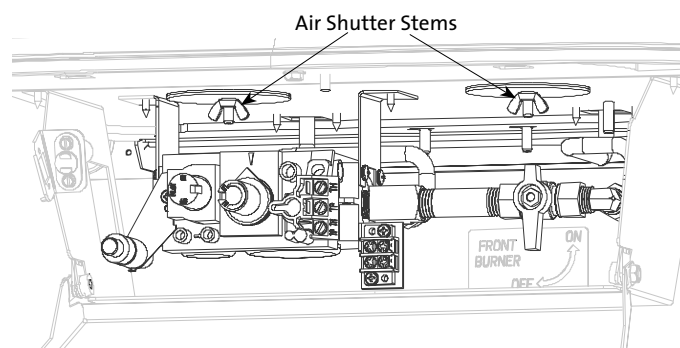

Figure 50.
Pull the shutter forward to increase primary air.
Push back to restrict air.

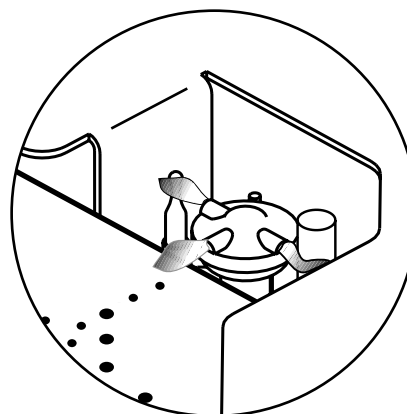

Figure 51. Proper pilot flame appearance relative to burner carry-over porting.

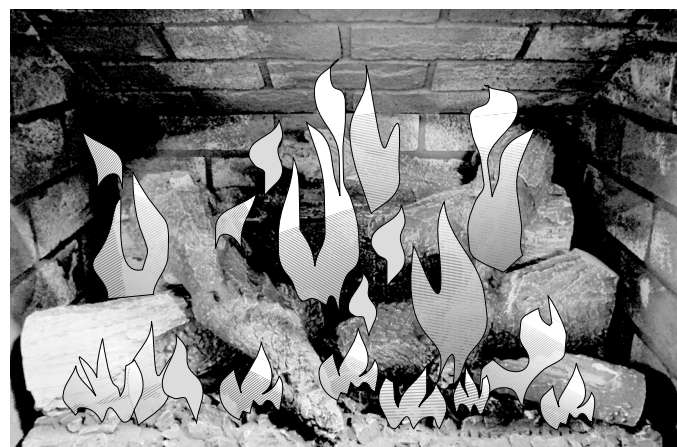

Figure 52. Steady state flame pattern - High setting.

Operation

WARNING:

READ AND UNDERSTAND ALL OPERATING INSTRUCTIONS BEFORE ATTEMPTING TO OPERATE THIS APPLIANCE. DO NOT ALLOW ANYONE TO OPERATE THIS APPLIANCE WHO HAS NOT READ AND UNDERSTOOD THESE INSTRUCTIONS.

WARNING:

DANGER OF SEVERE INJURY. THIS APPLIANCE CAN BE SET TO OPERATE THERMOSTATICALLY. BE AWARE THAT THE APPLIANCE MAY BE VERY HOT EVEN WHEN THE BURNER IS NOT APPARENTLY OPERATING. KEEP CHILDREN AWAY FROM THE APPLIANCE.

WARNING:

OBSERVE CAUTION NEAR THE GLASS PANEL. THE GLASS MAY SHATTER IF STRUCK BY AN OBJECT. ALWAYS HANDLE THE GLASS PANEL WITH CARE.

Follow the lighting instructions on the inside back cover of this manual.

1. **Front Burner Control:** Use the ball valve within the controls compartment to turn the front auxiliary burner on and off to increase or decrease the appliance input rate. **The valve should only be fully opened or fully closed. Do not use the valve to regulate the front burner flame intensity. Use only the main gas valve regulator knob to modulate flame height.**

2. For the first several hours of operation, it is common to detect some odor as the metal and manufacturing materials cure under heat. This condition is temporary and can be alleviated by allowing plenty of fresh air to circulate through the area.
3. Condensation may develop on the glass upon each lighting of the appliance. This “fog” will disappear as the glass heats.
4. **IMPORTANT: IT WILL BE NECESSARY TO CLEAN THE GLASS AFTER THE FIRST FEW FIRES. A white powdery residue will be evident which results from the burner media curing. Use a non-abrasive household glass cleaner and warm water. IF THE GLASS IS NOT CLEANED, THIS RESIDUE CAN CAUSE THE GLASS TO BECOME PERMANENTLY ETCHED. DO NOT USE AMMONIA-BASED CLEANERS.**
5. Keep the control compartments and area under the appliance free of dust. Always keep the appliance area clear and free from combustible materials, gasoline and other flammable liquids.
6. This appliance is operated with a continuously burning pilot flame. Exercise caution when using household products containing combustible vapors.
7. **CAUTION: DO NOT OPERATE THIS APPLIANCE WITH THE GLASS PANEL REMOVED, CRACKED OR BROKEN. REPLACEMENT OF THE GLASS SHOULD BE DONE BY A LICENSED OR QUALIFIED SERVICE PERSON. USE ONLY REPLACEMENT GLASS PROVIDED BY YOUR AUTHORIZED JØTUL DEALER. NEVER SUBSTITUTE ANY OTHER TYPE OF GLASS. REMOVE GLASS ONLY FOR ROUTINE SERVICE. ALWAYS HANDLE GLASS CAREFULLY.**

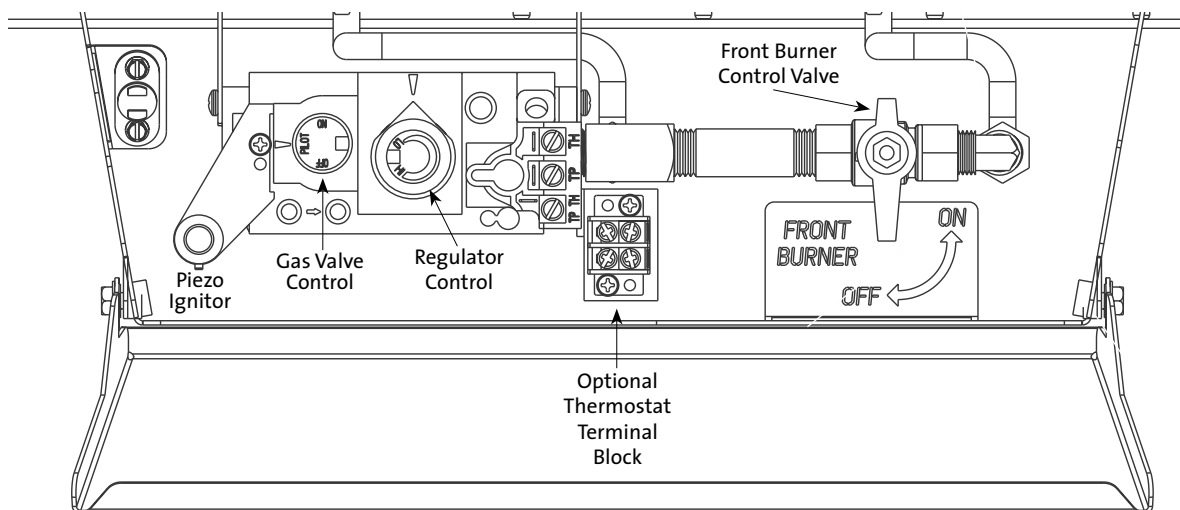

Figure 53. GF 500 DV Controls Compartment.

Maintenance

This appliance and its venting system should be inspected before use and at least annually by a qualified service technician.

IMPORTANT: ALWAYS TURN OFF THE GAS SUPPLY AND DISCONNECT POWER FROM THE APPLIANCE BEFORE ANY SERVICE WORK IS PERFORMED.

Annual Cleaning

Vent System

The entire vent system, including the chimney, should be inspected and cleaned every year. If the intake and exhaust venting is disassembled for any reason, it should be reassembled and sealed according to the manufacturer's instructions provided at the initial installation.

Burner System

Periodically inspect the firebox, valve compartment, convection airways and optional blower to **BE CERTAIN THAT THE FLOW OF COMBUSTION AND VENTILATION AIR IS UNOBSTRUCTED.**

The firebox and valve compartment should be vacuumed annually to remove any dust and debris. Use a soft brush attachment and handle the logs carefully as they are fragile. Vacuum more frequently if there are pets in the home.

The pilot assembly should be inspected and cleaned annually by a qualified technician. Any component showing corrosion should be replaced.

Glass Care

Clean the glass only when necessary. Wipe the surface with a clean, dampened, soft cloth. Follow with a dry, soft towel. Take care not to scratch the glass surface.

WARNING:
DO NOT USE ABRASIVE CLEANERS ON THE GLASS.
NEVER CLEAN THE GLASS WHEN IT IS HOT.
DO NOT USE AMMONIA-BASED CLEANING SOLUTIONS .

Glass and Gasket Inspection

NOTE: INSPECT THE GLASS SURFACE FOR SCRATCHES AS THESE CAN WEAKEN THE PANEL TENSILE STRENGTH. REPLACE THE PANEL IF ANY SCRATCHES ARE FOUND. USE ONLY JOTUL PN 225476. DO NOT USE ANY OTHER TYPE OF GLASS.

It is important that the glass gasket be inspected at least annually. Examine the ribbon gasket for signs of deterioration and make sure the gasket has a positive seal. Replace the gasket if necessary. Refer to the replacement parts list on page 34.

Glass Panel or Gasket Removal

1. Lift the Top Plate off of the stove.
2. Remove four hex head bolts using a 10 mm wrench and disengage the Top Convection Shroud from the top of the firebox. See fig. 2, page 5.
3. Release the two Glass Frame Latches. Pull each latch handle forward forward to disengage the latch from the notches in the glass frame.
4. Lift the glass frame all the way up and out of the top of the stove. Lay this assembly on a flat surface, protecting the frame from scratches using a blanket or towel.
5. The glass panel is held in place by four tabs on the frame. Use a screwdriver or small pliers to pry these up enough to release the glass panel. See fig. 54.
6. Remove the old gasket material.

Glass Panel or Gasket Replacement

1. Wrap the new gasket material evenly around the edge of the glass, peeling back the protective strip to expose the adhesive as you go. See fig. 55. Press the adhesive side down onto the glass surface. Do not stretch the gasket.
2. Place the gasketed glass within the frame and carefully bend each of the retainer tabs back to secure the glass in the frame. The replacement glass kit 157710 includes 4 compression clips for use in case a tab should break.



Figure 54. Bend the retainer tabs back enough to release the glass panel.

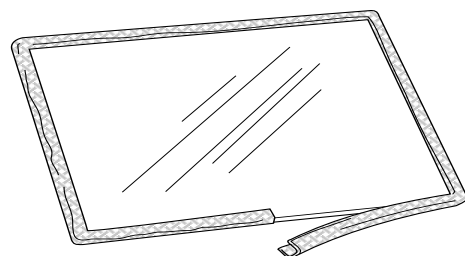

Figure 55. Wrap the gasket around the glass panel.

Appendix

Mobile Home Installation

The GF 500 DV is approved for use in a mobile home in the U.S. and Canada provided:

1. The stove is secured to the floor of the mobile home. Use Jøtul Floor Bracket Kit #750304.
2. Provision must be made to secure an electrical ground between the stove and the mobile home chassis.
3. The stove is installed in accordance with Title 24 CFR, Part 3280- Manufactured Home Construction and Safety Standard, in the U.S. In Canada, comply with CSA Z240.4, Gas Equipped Recreational Vehicles and Mobile Housing.
4. Always contact your local officials about installation restrictions and requirements in your area.

THIS APPLIANCE MAY BE INSTALLED AS AN OEM INSTALLATION IN A MANUFACTURED (MOBILE) HOME AND MUST BE INSTALLED IN ACCORDANCE WITH THE MANUFACTURER’S INSTRUCTIONS AND THE MANUFACTURED HOME CONSTRUCTION AND SAFETY STANDARD, TITLE 24 CFR, PART 3280. THIS APPLIANCE IS ONLY FOR USE WITH THE TYPE OF GAS THAT IS INDICATED ON THE STOVE’S RATING PLATE. A GAS CONVERSION KIT IS PROVIDED WITH THE GF 500 DV GAS STOVE.

THIS APPLIANCE MAY BE INSTALLED IN AN AFTERMARKET PERMANENTLY LOCATED, MANUFACTURED (MOBILE) HOME, WHERE NOT PROHIBITED BY LOCAL CODES.

GF 500 DV Accessories

Description	Part No.
Blower Kit	156000
Wall Thermostat	750003
Brick Panel Kit	157697
Short Leg Kit / Matte Black	350074
Short Leg Kit / Brown Majolica Enamel	351147
Leg Leveler	156096
Fuel Conversion Kit, Propane	157865
Fuel Conversion Kit, Natural Gas	157866
High Altitude Adjustment Kit / LP	157695
High Altitude Adjustment Kit / NG	157696
Snorkel Insulation Blanket	225606
Remote Control, On/Off	224910

GF 500 DV Illustrated Parts Breakdown

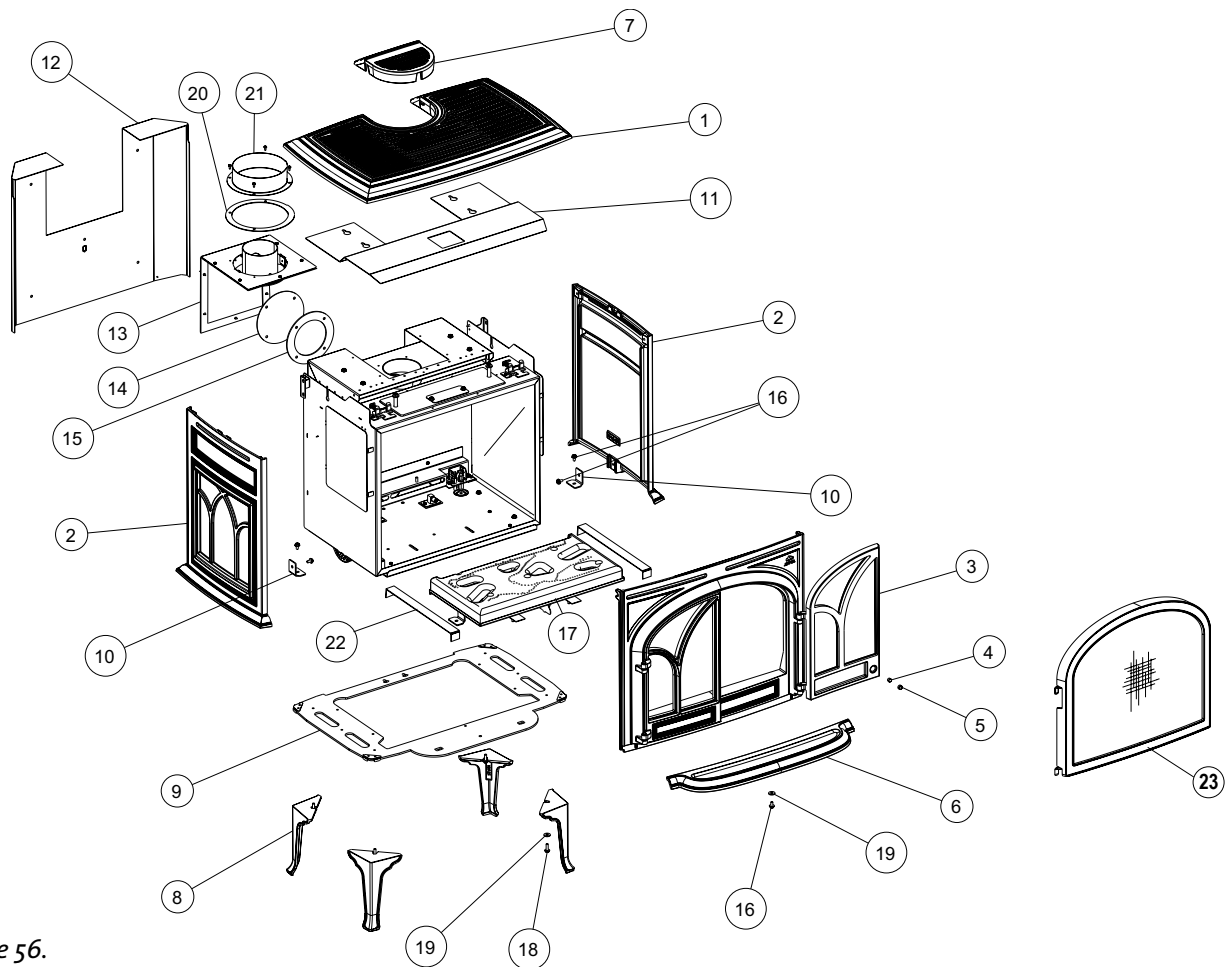

Figure 56.
Exterior replacement parts.

Cast Iron Parts	Matte Black Paint	Brown Majolica Enamel
1. Top Plate	10464892	10464847
2. Side Plate	10464992	157747
3. Front Assembly *	15770392	157749
6. Ash Lip	10465392	157748
7. Top Plate Insert	10465492	10465447
8. Leg, 8"	10192592	10192547

* Front Assembly includes:
Front Plate, Left & Right Doors, and Hinge Pins

No.	Part No.	Description
4.	225338	Door Magnet
5.	224909	Magnet Cap, Hi-temp Vinyl
9.	225453	Base Plate
10.	225601	Bracket, Side to Base
11.	22557092	Top Convection Shroud
12.	22584192	Rear Shroud
13.	157712	Vent Adaptor Assembly
14.	225459	Exhaust Cover Plate
15.	225530	Exhaust Gasket, 4"
16.	117130	Bolt, M6 x 12 mm, Hex Flange
17.	157707	Burner Assembly
18.	117117	Bolt, M6 x 20 mm, Hex Flange
19.	120004	Fender Washer, M6
20.	129118	Gasket, Vent Adaptor Collar - 6.625" dia.
21.	129322	Vent Adaptor Collar - 6.625" dia.
22.	225558	Side Brick Panel Support, 2
23.	157691	Safety Screen Barrier
24.	225474	Silicone Cap, Barrier Brackets - not illustrated

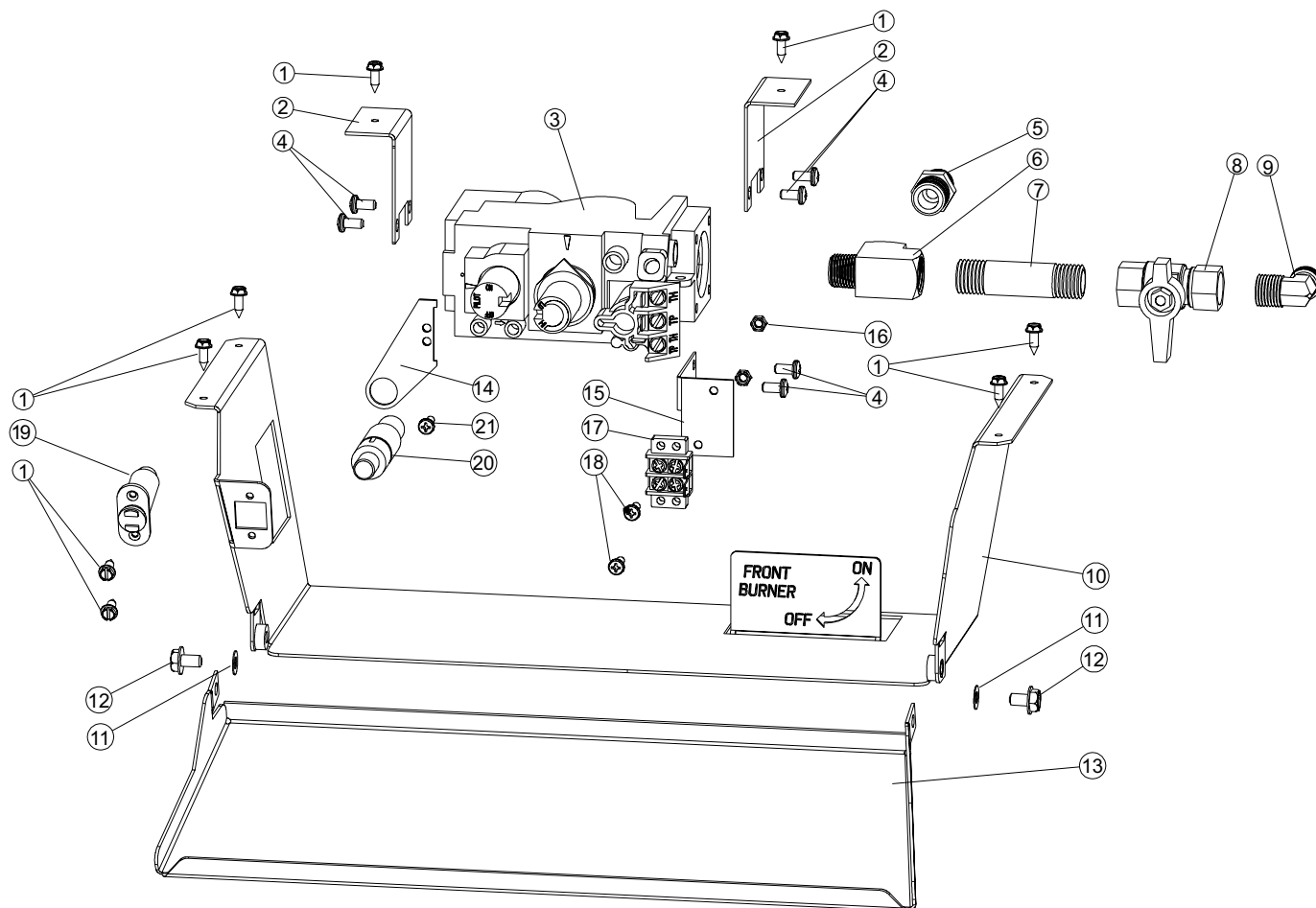

Figure 57.
GF 500 DV Millivolt Valve components.

No.	Part No.	Description
1.	117917	Screw, #8 x 1/2" SL Blk Oxide
2.	225838	Valve Bracket
3.	222263	Valve, NG 50% TD, 3.8" WC
4.	117911	Screw, Pan Hd 10-32 x 3/8"
5.	223215	Adaptor, 3/8 NPT x 3/8 flare
6.	225866	Brass Tee, F x F x M, 3/8 NPT
7.	222406	Nipple, 3/8 NPT x 2.5"
8.	222407	Shut-off Valve, 3/3 FIP x 3/8 FIP
9.	222292	Elbow, 3/8 NPT x 3/8 Flare
10.	22583992	Control Bracket, MB
11.	117588	Washer, Hinge - 12mm OD x 6mm ID

No.	Part No.	Description
12.	9962	Bolt, Hex M6 x 10 DIN 933 Blk
13.	225457	Control Door
14.	3902576	Ignitor Bracket
15.	220614	Terminal Block Bracket
16.	117922	Nut, M4 DIN 934 Plain, 1
17.	129154	Terminal Block, 2 pole
18.	117921	Screw, Ph Pan Hd, M4 x 12 Blk
19.	224145	Magnetic Catch
20.	3902573	Piezo Ignitor Button
21.	117920	Screw, Ph Pan Hd, M4 x 8, zinc

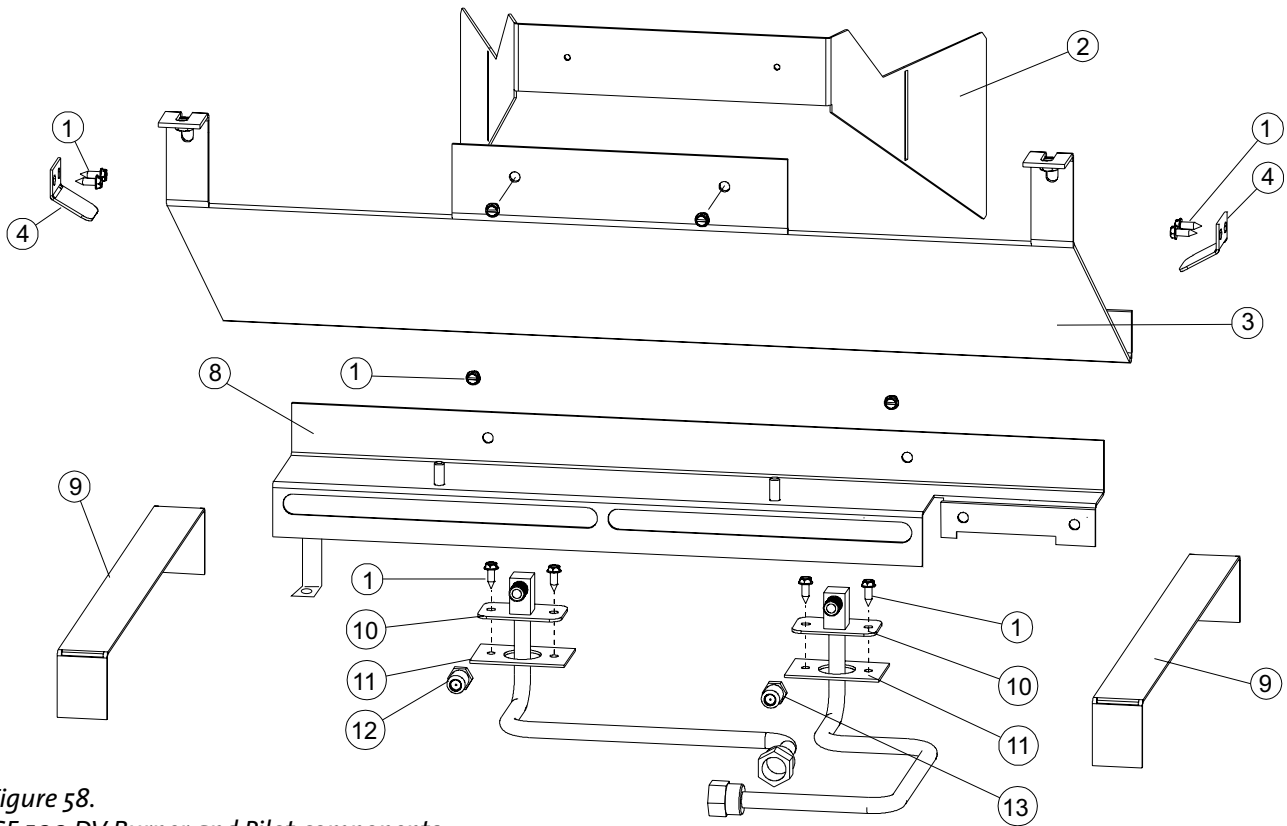
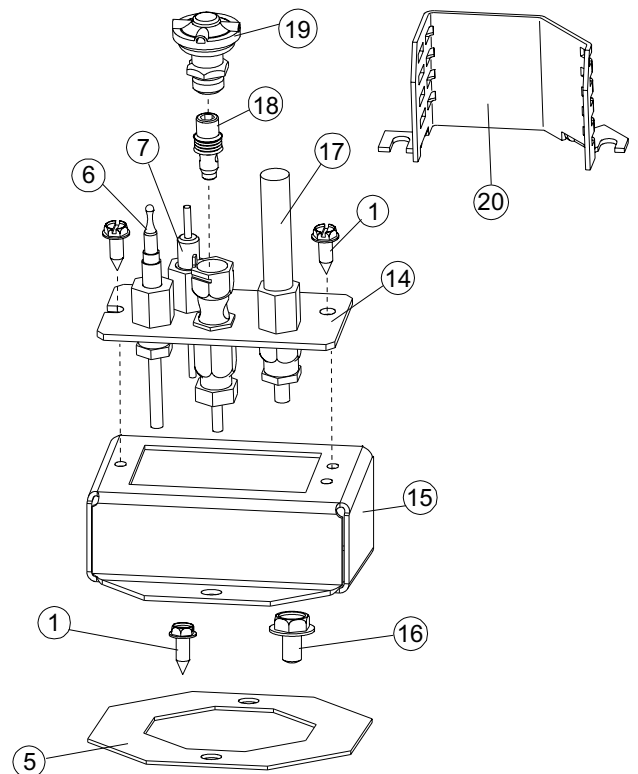

Figure 58.
GF 500 DV Burner and Pilot components.

No.	Part No.	Description
1.	117917	Screw 8 x 12 1/2 SL Blk Oxide
2.	225528	Exhaust Baffle Wing
3.	22545692	Exhaust Baffle
4.	224931	Brick Panel Retainer
5.	225864	Gasket, Pilot Assembly
6.	129766	Thermocouple, Standard w/ fittings
7.	129765	Electrode, inc. wire, STD (Pop-top)
8.	22547092	Burner Skirt
9.	22555892	Brick Panel Shelf
10.	223231	Orifice Holder, Drop-in Assembly
11.	222280	Gasket, Drop-in Orifice Holder
12.	225536	Orifice, 2.25 mm / Left, Rear Flames - NG
	129804	Orifice, 1.40 mm / Left, Rear Flames - LP
13.	220976	Orifice, #47 / Right, Front Flames - NG
	221185	Orifice, 1.20 mm / Right, Front Flames - LP
14.	129471	Pilot Assembly / NG
15.	225849	Pilot Spacer
16.	9962	Bolt, Hex Cap, M6 x 10
17.	3094527	Thermopile, Cast. Nova 820 valves
18.	129473	Orifice, Pilot, #30 / LP
	129472	Orifice, Pilot, #51 / NG
19.	220384	Pilot Hood, 3 flames, Nova 820
20.	224917	Pilot Shield, SIT



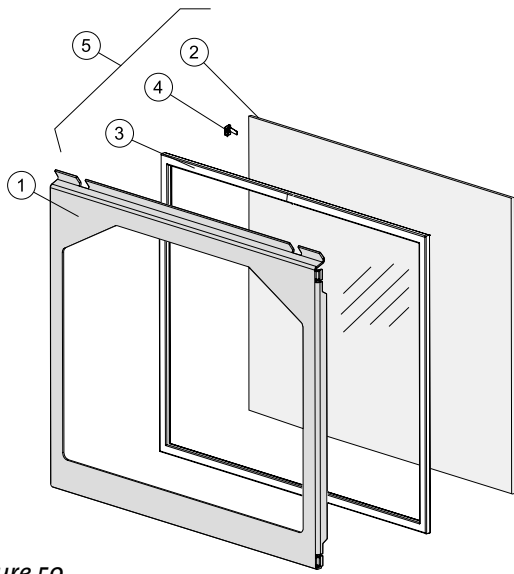

Figure 59.
GF 500 DV Glass Assembly

No.	Part No.	Description
1.	22545492	Glass Frame
2.	225476	Glass Panel, Ceramic
3.	129124	Gasket, Tadpole - .25 dia. x 1.25", 6 ft.
4.	220042	Replacement Glass Clips, 4
5.	157710	Replacement Glass Kit, GF 500 DV

Replacement Double-sided Brick Panel Parts / See pg.. 22

1.	225594	Rear Panel
2.	225595	Baffle Panel
3.	225596	Side Panel, A1
4.	225597	Side Panel, 2A

Replacement Log Set Parts / See pg.. 25

No.	Part No.	Description
1	225587	Rear Log
2.	225585	Lower Left Log
3.	225589	Lower Right Log
4.	225586	Upper Left Log
5.	225588	Upper Right Log
6.	225590	Small Front Log
7..	225451	Ember Stones
8.	157259	Rock Wool, 1 oz.
9.	157706	Complete Log Set

Jøtul Gas Product Warranty

This warranty policy applies to gas products identified by Jøtul, Scan, and Atra trade names, as set forth below.

A. LIMITED FIVE YEAR WARRANTY - Cast Iron, Steel Doors, Surround Components, Firebox:

Jøtul North America Inc. (JØTUL) warrants, to the original retail purchaser, that those components of the Jøtul, Scan, or Atra Gas Stove or Fireplace specified above will be free of defects in material and workmanship for a period of five (5) years from the date of purchase. This warranty is subject to the terms, exclusions and limitations set forth in the following text.

B. LIMITED TWO YEAR WARRANTY - Burner, Ceramic Burner, Burner Treatments, Firebox Panels:

JØTUL warrants, to the original retail purchaser, that those components of the Jøtul, Scan, or Atra Gas Stove or Fireplace specified above will be free of defects in material and workmanship for a period of two (2) years from the date of purchase. **Ceramic burners** are warranted against functional defects for a period of two (2) years from the date of purchase. This warranty is subject to the terms, exclusions, and limitations set forth in the following text.

C. LIMITED TWO YEAR WARRANTY - Enamel Finish:

JØTUL warrants, to the original retail purchaser, the enamel finish on cast iron components of the Jøtul Stove or Fireplace Insert specified above against peeling or fading for a period of two (2) years from the date of purchase. This warranty is subject to the terms, exclusions and limitations set forth below.

D. LIMITED ONE YEAR WARRANTY - Gas & Electrical Components (controls, plumbing, valve, blower):

JØTUL warrants, to the original retail purchaser, that those components of the Jøtul, Scan, or Atra Gas Stove or Fireplace specified above will be free of defects in material and workmanship for a period of one (1) year from the date of purchase. This warranty is subject to the terms, exclusions, and limitations set forth in the following text.

JØTUL will repair or replace (including parts & labor), at its option, any of the above components determined by JØTUL to be covered by this warranty. You must, at your own expense, arrange to deliver or ship the component to an authorized Jøtul, Scan, or Atra dealer and arrange for pickup or delivery of the component after repairs have been made. If, upon inspection, JØTUL determines that the component is covered by this warranty, the repair or replacement will be made as set forth above. This warranty is not transferable and is extended only to, and is solely for the benefit of, the original retail purchaser of the Jøtul, Scan, or Atra Gas Stove or Fireplace. This paragraph sets forth the sole remedy available under this warranty in the event of any defect in the Jøtul, Scan, or Atra Gas Stove or Fireplace.

The warranty period for any replaced component will be the remaining unexpired portion of the warranty period for the original component. Please retain your dated sales receipt in your records as proof of purchase.

EXCLUSIONS AND LIMITATIONS

NOTICE: This warranty is void if installation or service is performed by someone other than an authorized installer, service agency or gas supplier, or if installation is not in conformance with the installation and operating instructions contained in this owner's manual or local and/or national fire and building regulations. A listing of local authorized installers, service agencies and gas suppliers can be obtained from the National Fireplace Institute at <http://www.nficertified.org/>.

This warranty does not cover the following:

- 1) Repair or replacement of parts that are subject to normal wear and tear during the warranty period or to parts that may require

replacement in connection with normal maintenance. These parts include gaskets and glass (except to the extent such parts suffer damage from thermal stress).

- 2) Damage due to incorrect installations not in conformance with the installation instructions contained in this owner's manual or local and/or national fire and building regulations.
- 3) Damage due to service performed by an installer, service agency or gas supplier, unless otherwise agreed to in writing by JØTUL.
- 4) Labor or other costs associated with the repair of gas controls, plumbing, burners, log set, or sheet metal firebox beyond the warranty period.
- 5) Damage caused by unauthorized modification, use or repair.
- 6) Damage to enameled surfaces caused by improper operation or misuse, including use that is not in conformance with the operating instructions contained in this owner's manual. Such damage can typically be identified by bubbling, cracking, or discoloration of the enamel finish.
- 7) Costs incurred by travel time and/or loss of service.
- 8) Damage incurred while the Jøtul, Scan, or Atra Gas Stove or Fireplace is in transit.

IN NO EVENT SHALL JØTUL, ITS PARENT COMPANY, SHAREHOLDERS, AFFILIATES, OFFICERS, EMPLOYEES, AGENTS OR REPRESENTATIVES BE LIABLE OR RESPONSIBLE TO YOU FOR ANY SPECIAL, INDIRECT, INCIDENTAL, CONSEQUENTIAL, PUNITIVE OR OTHER SIMILAR DAMAGES, INCLUDING, BUT NOT LIMITED TO, LOST PROFITS, LOST SALES, INJURY TO PERSON OR PROPERTY, OR DAMAGES TO A STRUCTURE OR ITS CONTENTS, ARISING UNDER ANY THEORY OF LAW WHATSOEVER. ALL IMPLIED WARRANTIES, INCLUDING THE IMPLIED WARRANTIES OF MERCHANTABILITY AND FITNESS FOR A PARTICULAR PURPOSE, OR OTHERWISE, ARE LIMITED IN DURATION TO THE LENGTH OF THIS WRITTEN WARRANTY. EXCEPT AS EXPRESSLY SET FORTH HEREIN, JØTUL MAKES NO ORAL, WRITTEN OR OTHER WARRANTY WITH RESPECT TO JØTUL, SCAN OR ATRA GAS STOVES OR FIREPLACES.

Some states do not allow the exclusion or limitation of incidental or consequential damages, or limitations on the length of implied warranties. Therefore, the above exclusions or limitations may not apply to you. This warranty gives you specific legal rights, and you may have other rights, which vary from state to state.

JØTUL reserves the right to discontinue, modify or change the materials used to produce the Jøtul, Scan, or Atra Gas Stove or Fireplace. JØTUL shall have the right to replace any defective component with substitute components determined by JØTUL to be of substantially equal quality and price.

The dollar value of JØTUL's liability for breach of this warranty shall be limited exclusively to the cost of furnishing a replacement component. JØTUL shall not in any event be liable for the cost of labor expended by others in connection with any defective component. Any costs or expenses beyond those expressly assumed by JØTUL under the terms of this warranty shall be the sole responsibility of the owner(s) of the Jøtul, Scan, or Atra Gas Stove or Fireplace.

No dealer, distributor, or other person is authorized to modify, augment, or extend this limited warranty on behalf of JØTUL. NO MODIFICATION OR CHANGE TO THIS WARRANTY WILL BE EFFECTIVE UNLESS IT IS MADE IN A WRITTEN DOCUMENT MANUALLY SIGNED BY AN AUTHORIZED OFFICER OF JØTUL.

An authorized installer may have been provided with certain information related particularly to the Jøtul, Scan, or Atra Gas Stove or Fireplace; however, no authorized installer or other person who may service the appliance is an agent of JØTUL. No inference should be made that JØTUL has tested, certified, or otherwise pronounced any person as qualified to install or service the appliance. JØTUL shall not be liable or otherwise responsible for any error or omission by a person installing or servicing a Jøtul, Scan, or Atra Gas Stove or Fireplace.

If you believe your Jøtul, Scan, or Atra Gas Stove or Fireplace is defective, you should contact your nearest authorized Jøtul, Scan, or Atra dealer, who will process a warranty claim. IN ORDER TO QUALIFY FOR WARRANTY COVERAGE, JØTUL MUST RECEIVE NOTICE OF A POSSIBLE DEFECT WITHIN SIXTY (60) DAYS OF THE DATE THE DEFECT IS FIRST DISCOVERED, OR REASONABLY COULD HAVE BEEN DISCOVERED.

This warranty is given by Jøtul North America, Inc.,
55 Hutcherson Drive, Gorham, Maine 04038 USA

This page is intentionally blank.

This page is intentionally blank.

This page is intentionally blank.

LIGHTING INSTRUCTIONS

FOR YOUR SAFETY, READ BEFORE LIGHTING.

WARNING:
IF YOU DO NOT FOLLOW THESE INSTRUCTIONS EXACTLY, A FIRE OR EXPLOSION MAY RESULT CAUSING PROPERTY DAMAGE, PERSONAL INJURY, OR LOSS OF LIFE.

- A. This appliance has a pilot which must be lit by hand. When lighting the pilot, follow these instructions exactly.
- B. **BEFORE LIGHTING**, smell all around the appliance area for gas. Be sure to smell next to the floor because some gas is heavier than air and will settle to the floor.
- WHAT TO DO IF YOU SMELL GAS:**
- Extinguish any open flame.
 - Open windows.
 - Do not light any appliance.
 - Do not touch any electrical switches.
 - Do not use any phone in your building.
 - Immediately call your gas supplier from a neighbor's phone.
- If your gas supplier cannot be reached, call the fire department.
- C. Use only your hand to push in or turn the gas control knob. Never use tools. If the knob will not push in or turn by hand, do not try to repair it. Call a qualified technician. Force or attempted repair may result in a fire or explosion.
- D. Do not use this appliance if any part has been under water. Immediately call a qualified service technician to inspect the appliance and to replace any part of the control system and any gas control which has been under water.

LIGHTING INSTRUCTIONS

1. STOP! Read the safety information above.
2. Set the BURNER ON/OFF switch to "OFF", or set the thermostat to lowest setting (if used).
3. Confirm that the gas supply line shut-off valve is open.

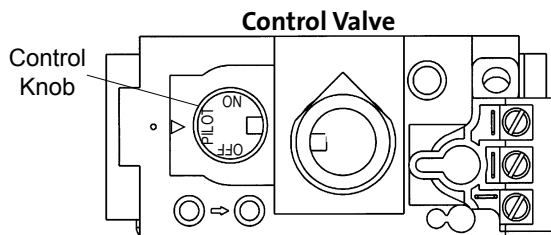

4. Push in Valve Control knob slightly and turn clockwise to "OFF".
 NOTE: Knob cannot be turned from "PILOT" to "OFF" unless the knob is pushed in slightly. Do not force.
5. Wait five (5) minutes to clear out any gas. If you then smell gas, STOP! Follow "B" in the safety information above on this page. If you do not smell gas, go to the next step.

6. Push in Valve Control knob slightly and turn counter-clockwise to "PILOT".
7. Push in control knob all the way and hold in. Immediately light the pilot by triggering the spark ignitor (push the red button repeatedly) until pilot lights. Continue to hold the control knob in for about one minute after the pilot lights. Release knob and it should spring back. The pilot should remain lit. If it goes out, repeat Steps 5 through 7.

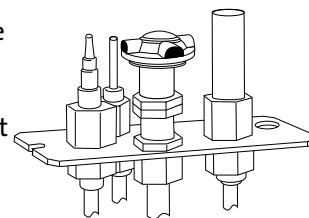

Pilot Assembly

- If knob does not return when released, stop and immediately call your service technician or gas supplier.
 - If pilot will not stay lit after several tries, turn the control knob to OFF and call your service technician or gas supplier.
8. Turn Valve Control knob counter-clockwise to "ON".
 9. Set the BURNER switch to "ON", or set thermostat (if used) to desired temperature.

TO TURN OFF GAS TO THE APPLIANCE:

1. Place BURNER switch in "OFF" position. The pilot will remain lit for normal service.
2. For complete shutdown, depress the Valve Control Knob and turn clockwise to "OFF". Do not force.

December, 2016
139760_A

This appliance must be installed in conformance with local and national building regulations. Before beginning the installation, it is important that these instructions be carefully read and understood. Jøtul maintains a policy of continual product development. Consequently, products may differ in specification, color or type of accessories from those illustrated or described in various publications.

Your stove has a unique serial number stamped on the rating plate which is hung on the back. Please record the serial number in the space below. You may also wish to attach your purchase receipt to this page for future reference.

MODEL NAME: Jøtul GF 500 DV

SERIAL NUMBER: _____

DATE OF PURCHASE: _____

AUTHORIZED DEALER: _____

ADDRESS _____

PHONE: _____

INSTALLER: _____

FUEL TYPE: _____

FUEL CONVERSION: NO _____ YES _____

INSTALLATION DATE: _____

INSTALLATION TECHNICIAN: _____

Jøtul North America

55 Hutcherson Dr.
Gorham, Maine 04038-2634

Jøtul ASA

P.O. Box 1411
N-1602 Fredrikstad
Norway

