

INSTALLATION MANUAL

INSTALLER:

Leave this manual with the appliance.

CONSUMER:

Retain this manual for future reference.



WARNING: If the information in these instructions is not followed exactly a fire or explosion may result causing property damage, personal injury or death.

FOR YOUR SAFETY

Installation and service must be performed by a qualified installer, service agency or the gas supplier

WHAT TO DO IF YOU SMELL GAS

- Do not try to light any appliance.
- Do not touch any electrical Switch.
- Do not use any phone in your building.
- Immediately call your gas supplier from a neighbour's phone. Follow the gas supplier's instructions.
- If you cannot reach your gas supplier call the fire department.

Do not store or use gasoline or other flammable vapours and liquids in the vicinity of this or any other appliance.

This appliance is suitable for installation in a bedroom or bed sitting room.

This appliance may be installed in an after-market permanently located, manufactured home (USA only) or mobile home, where not prohibited by local codes.

This appliance is only for use with the type of gas indicated on the rating plate. This appliance is not convertible for use with other gases unless a certified kit is used.

INSTALLATION INSTRUCTIONS

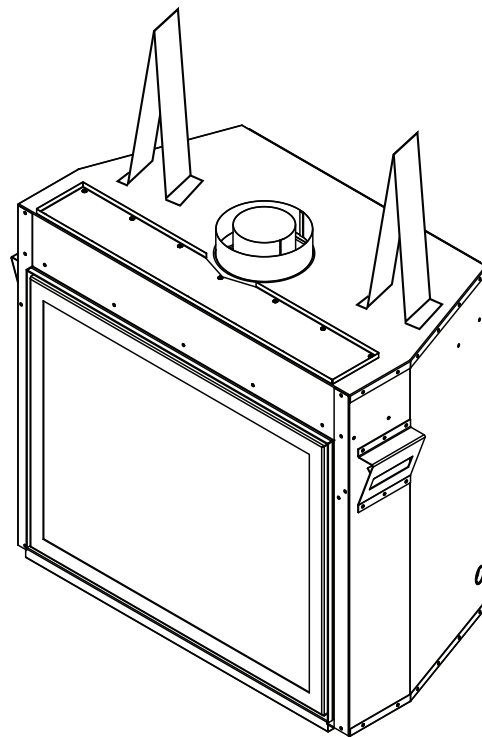

MODEL: z35
SERIES: A
ZERO CLEARANCE
DIRECT VENTED GAS
FIREPLACE HEATER



Visit www.pacificenergy.net for the most recent version of this manual

Table of Contents

<p>Important Note for the Commonwealth of Massachusetts 3</p> <p>Caution 4</p> <p>Safety 5</p> <p>Fireplace Dimensions 6</p> <p>Locating the Fireplace 7</p> <p>Framing and Finishing 8</p> <p>Framing in the z35 9</p> <p>Framing in the z35 and Optional Cool Wall Venting Kit 9</p> <p>Lower Opening Trim Piece 11</p> <p>Clearances to Combustibles 12</p> <p style="padding-left: 20px;">Standard Configuration 12</p> <p style="padding-left: 20px;">Cool Wall Kit 12</p> <p style="padding-left: 20px;">Configuration 12</p> <p>Venting Chart 16</p> <p>Vent Terminal Minimum Clearances 17</p> <p>Venting Configuration 18</p> <p>Vertical Termination 19</p> <p style="padding-left: 20px;">Vertical Termination using a Duravent Terminal.. 19</p> <p style="padding-left: 20px;">Vertical Termination using an ICC Terminal 19</p> <p>Horizontal Termination 20</p> <p style="padding-left: 20px;">Horizontal Termination using a Duravent Terminal..... 20</p> <p style="padding-left: 20px;">Horizontal Termination using an ICC Terminal ... 20</p> <p>Electrical Connection 21</p> <p>Wall Switch Installation 22</p> <p>Home Automation 23</p> <p>Control Overview 24</p> <p>Gas Valve for Configuration 25</p> <p style="padding-left: 20px;">Gas valve and control module..... 25</p>	<p>Gas Connection 26</p> <p>Gas Supply 27</p> <p>Gas Pressure Check 27</p> <p style="padding-left: 20px;">Gas pressure requirements 27</p> <p>Gas Pressure Testing Procedure 29</p> <p>Gas Leak Detection 30</p> <p>Lighting Instructions 31</p> <p>Panel Installation 32</p> <p>Glass Baffle Installation 34</p> <p>Log Set Installation 35</p> <p>Glass Media Installation 41</p> <p>Door Installation/Removal 42</p> <p>Front Surround Installation/Removal 43</p> <p>Venturi Adjustment 44</p> <p>Damper Adjustment 45</p> <p>Control Panel Removal / Installation 46</p> <p>Maintenance 47</p> <p style="padding-left: 20px;">Glass Door: 47</p> <p style="padding-left: 20px;">Annual Inspection: 47</p> <p style="padding-left: 20px;">Periodically: 47</p> <p>Pairing the Control Module and Fireplace 48</p> <p style="padding-left: 20px;">Step 1: Procedure for linking / pairing wall switch to fireplace 48</p> <p style="padding-left: 20px;">Step 2: Procedure for linking / pairing the wall switch to remote handset..... 49</p> <p>Halogen Lamp Replacement 50</p> <p>Module & Gas Valve Details 51</p> <p>Wiring Diagram 52</p> <p>Replacement Parts 53</p> <p>Rating Label 55</p>
---	---



WARNING: This product can expose you to chemicals including ceramic fibers, which are known to the State of California to cause cancer, and carbon monoxide, which is known to the State of California to cause birth defects or other reproductive harm.

For more information go to www.P65Warnings.ca.gov.

This warning is applicable to all **Pacific Energy Fireplace Products**

— Important Note for the Commonwealth of Massachusetts —

From Massachusetts Rules and Regulations 248 CMR 5.08:

- (a) For all side wall horizontally vented gas fueled equipment installed in every dwelling, building or structure used in whole or in part for residential purposes, including those owned or operated by the Commonwealth and where the side wall exhaust vent termination is less than seven (7) feet above finished grade in the area of the venting, including but not limited to decks and porches, the following requirements shall be satisfied.
1. **INSTALLATION OF CARBON MONOXIDE DETECTORS.** At the time of installation of the side wall horizontal vented gas fueled equipment, the installing plumber or gas fitter shall observe that a hard wired carbon monoxide detector with an alarm and battery back-up is installed on the floor level where the gas equipment is to be installed, in addition, the installing plumber or gas fitter shall observe that a battery operated or hard-wired carbon monoxide detector with an alarm is installed on each additional level of the dwelling, building or structure served by the side wall horizontal vented gas fueled equipment. It shall be the responsibility of the property owner to secure the services of qualified licensed professionals for the installation of hard-wired carbon monoxide detectors.
 - a. In the event that the side wall horizontally vented gas fueled equipment is installed in a crawl space or an attic, the hard-wired carbon monoxide detector with alarm and battery back-up may be installed on the next adjacent floor level.
 - b. In the event that the requirements of this subdivision cannot be met at the time of completion of installation, the owner shall have a period of thirty (30) days to comply with the above requirements; provided, however, that during said thirty (30) day period, a battery operated carbon monoxide detector with an alarm shall be installed.
 2. **APPROVED CARBON MONOXIDE DETECTORS.** Each carbon monoxide detector as required in accordance with the above provisions shall comply with NFPA 720 and be ANSI/UL 2034 listed as IAS certified.
 3. **SIGNAGE.** A metal or plastic identification plate shall be permanently mounted to the exterior of the building at a minimum height of eight (8) feet above grade directly in line with the exhaust vent terminal for the horizontally vented gas fueled heating appliance or equipment. The sign shall read, in print size no less than one-half (1/2) inch in size, "GAS VENT DIRECTLY BELOW. KEEP CLEAR OF ALL OBSTRUCTIONS"
 4. **INSPECTION.** The state or local gas inspector of the side wall horizontally vented gas fueled equipment shall not approve the installation unless, upon inspection, the inspector observes carbon monoxide detectors and signage installed in accordance with the provisions of 248 CMR 5.089(2) (a) 1 through 4.
- (b) **EXEMPTIONS.** The following equipment is exempt from 248 CMR 5.089(2)(a) 1 through 4.
1. The equipment listed in Chapter 10 entitled "Equipment Not Required To Be Vented" in the most current edition of NFPA 54 as adopted by the Board; and
 2. Product Approved side wall horizontal vented gas fueled equipment installed in a room or structure separate from the dwelling, building or structure used in whole or in part for residential purposes.
- (c) **MANUFACTURER REQUIREMENTS – GAS EQUIPMENT VENTING SYSTEM PROVIDED.** When the manufacturer of Product Approved side wall horizontally vented gas equipment provides a venting system design or venting system components with the equipment, the instructions provided by the manufacturer for installation of the equipment and the venting system shall include:
1. Detailed instructions for the installation of the venting system design or the venting system components; and
 2. A complete parts list for the venting system design or venting system.
- (d) **MANUFACTURER REQUIREMENTS – GAS EQUIPMENT VENTING SYSTEM NOT PROVIDED.** When the manufacturer of a Product Approved side wall horizontally vented gas fueled equipment does not provide the parts for venting the fuel gases, but identifies "special venting systems," the following requirements shall be satisfied by the manufacturer.
1. The referenced "special venting system" instructions shall be included with the appliance or equipment installation instructions; and
 2. The "special venting systems" shall be Product Approved by the Board, and the instructions for that system shall include a parts list and detailed installation instructions.
- (e) A copy of all installation instructions for all Product Approved side wall horizontally vented gas fueled equipment, all venting instructions, all parts lists for venting instructions, and/or all venting design instructions shall remain with the appliance or equipment at the completion of the installation.

Caution

FOR YOUR SAFETY - Do not install or operate your Pacific Energy fireplace without first reading and understanding this manual. Any installation or operational deviation from the following instructions voids the Pacific Energy Warranty and may prove hazardous.

This appliance and its individual shut off valve must be disconnected from gas supply piping system during any pressure testing of that system at test pressures in excess of 1/2 psi (3.5 kPa).

This appliance must be isolated from the gas supply piping system by closing its individual manual shut off valve during any pressure testing of the gas supply piping system at test pressures equal to or less than 1/2 psi (3.5 kPa).

Do not use the fireplace if any part has been under water. Immediately call a qualified service technician to inspect the fireplace and to replace any part of the control system and any gas control which has been under water.

This fireplace is equipped with a micro mesh safety screen for your protection and must be installed with the unit. Removal of the safety screen will cause the fireplace to become a burn and fire hazard.



DANGER



**HOT GLASS WILL CAUSE
BURNS.**

**DO NOT TOUCH GLASS UNTIL
COOLED.**

**NEVER ALLOW CHILDREN TO
TOUCH GLASS.**

A barrier designed to reduce the risk of burns from the hot viewing glass is provided with the appliance and shall be installed for the protection of children and other at-risk individuals.

Safety

- Due to high temperatures, this gas appliance should be located out of traffic and away from furniture and draperies.
- Children and adults should be alerted to the hazards of high surface temperatures and should stay away to avoid burns or clothing ignition.
- Young children should be carefully supervised when they are in the same room as the appliance. Toddlers, young children and others may be susceptible to accidental contact burns. A physical barrier is recommended if there are at risk individuals in the house. To restrict access to a fireplace or stove, install an adjustable safety gate to keep toddlers, young children and other at risk individuals out of the room and away from hot surfaces.
- Clothing or other flammable material should not be placed on or near the appliance.
- A barrier designed to reduce the risk of burns from the hot viewing glass is provided with the fireplace and shall be installed.
- If the barrier becomes damaged, the barrier shall be replaced with the manufacturers barrier for this appliance.
- Any grill, panel or door removed for servicing the unit must be replaced prior to operating.
- Installation and repair should be done by a qualified service person. The appliance should be inspected before use and at least annually by a professional service person. More frequent cleaning may be required due to excessive lint from carpeting, bedding material, etc. It is imperative that control compartments, burners and circulating air passageways of the appliance be kept clean.
- This appliance must not be connected to a chimney flue serving a separate solid fuel burning appliance.
- It is our policy that no responsibility is assumed by the Company or by any of its employees or representatives for any damages caused by an inoperable, inadequate, or unsafe condition which is the result, either directly or indirectly, of any improper operation or installation procedures.

Fireplace Dimensions

The installation must conform with local codes or, in the absence of local codes, with the National Fuel Gas Code, ANSI Z223.1/NFPA 54, or the National Gas and Propane Installation Code, CSA B149.1

A manufactured home (USA only) or mobile home OEM installation must conform with the Manufactured Home Construction and Safety Standard, Title 24 CFR, Part 3280, or, when such a standard is not applicable, the Standard for Manufactured Home Installations, ANSI/NCSCBS A225.1, or standard for Gas Equipped Recreational Vehicles and Mobile Housing, CSA Z240.4

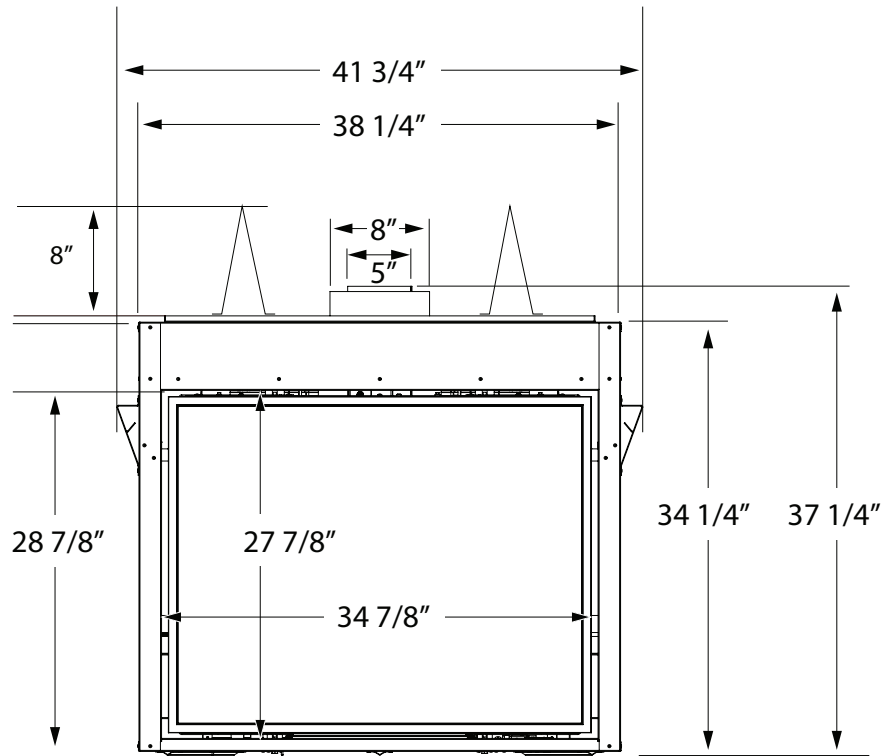

Figure 1: Front view.

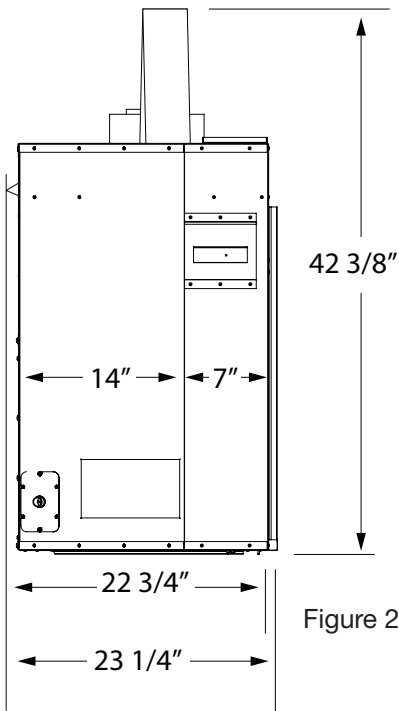

Figure 2: Side view.

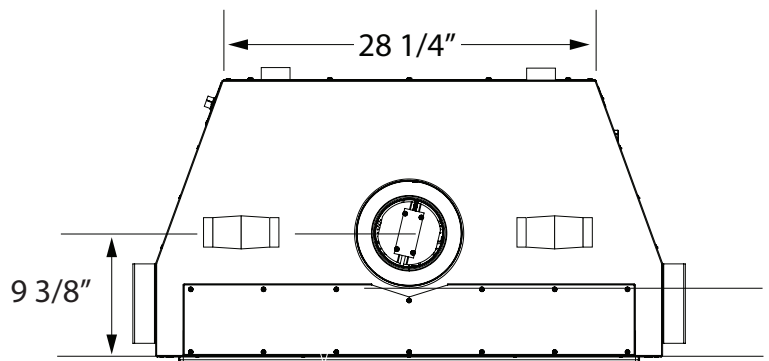

Figure 3: Top view.

Locating the Fireplace

In planning the installation for the fireplace, it is necessary to determine where the unit is to be installed, location of vent system and where gas supply piping may be plumbed. Various installations are possible, such as, into an existing wall, a corner, a built in wall or a wall projection. Due to high temperatures, do not locate this fireplace in areas of high traffic or near furniture or draperies. For places where a second side wall is specified, fireplace should be accessible for service

Front of the appliance is an open side of the combustion chamber covered with the glass.

Facing the front of the appliance side from left is the left side of the appliance and side from right is the right side of the appliance.

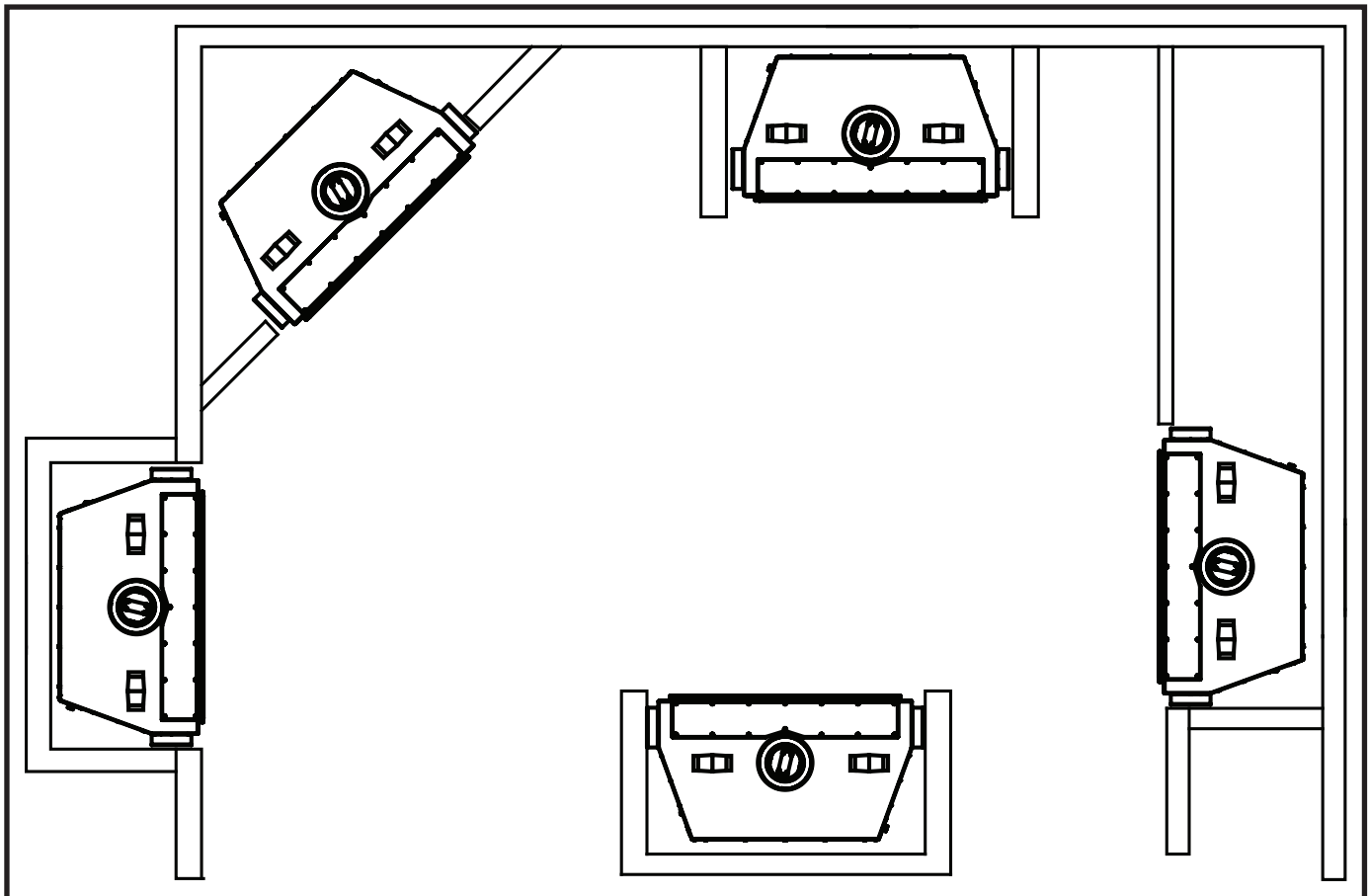

Figure 4: Common installation examples.

Framing and Finishing

Note: This fireplace should be in place and venting installed before framing in or building an enclosure around the unit.

The z35 fireplace must be framed in as described below or totally enclosed with non-combustible material, such as facing brick.

If preferred, additional masonry type non-combustible material can be installed above the appliance.

The finishing material must not interfere with glass door and safety screen removal.

The sides, back and top of the fireplace can be framed in using conventional lumber. Consult local building codes for specific requirements.

Due to high temperatures, non-combustible material board, such as cement board or its equivalent, must be used to sheet in above the fireplace, extending a minimum of 13" above the fireplace opening so that the top of the non-combustible board is level with the top of the standoffs - (Figure 20 on page 15). Standard sheet rock (dry wall) may be used up to the sides of the fireplace opening.

A header using two 2 x 4's must be installed so that the bottom of the header is level with the top standoffs (Figure 5). This header will support both combustible and non-combustible facing material above the fireplace opening.

If backer board is not to be used, other non-combustible material such as tiles may be used. It is recommended that top sections of the board be a single sheet of calcium silicate board or its equivalent. Taped and mudded joints may crack due to the elevated temperatures.

Chase Insulation: When installing this fireplace against a non-insulated exterior wall or chase, it is recommended that the outer walls be insulated to same degree as other exterior walls. Do not place fireplace directly against the insulation. Cover the insulation and plastic vapour barrier with a solid surface, such as dry wall (sheet rock). Consult local codes. Do not insulate between the top of the fireplace and the top of the stand-offs.

Framing in the z35

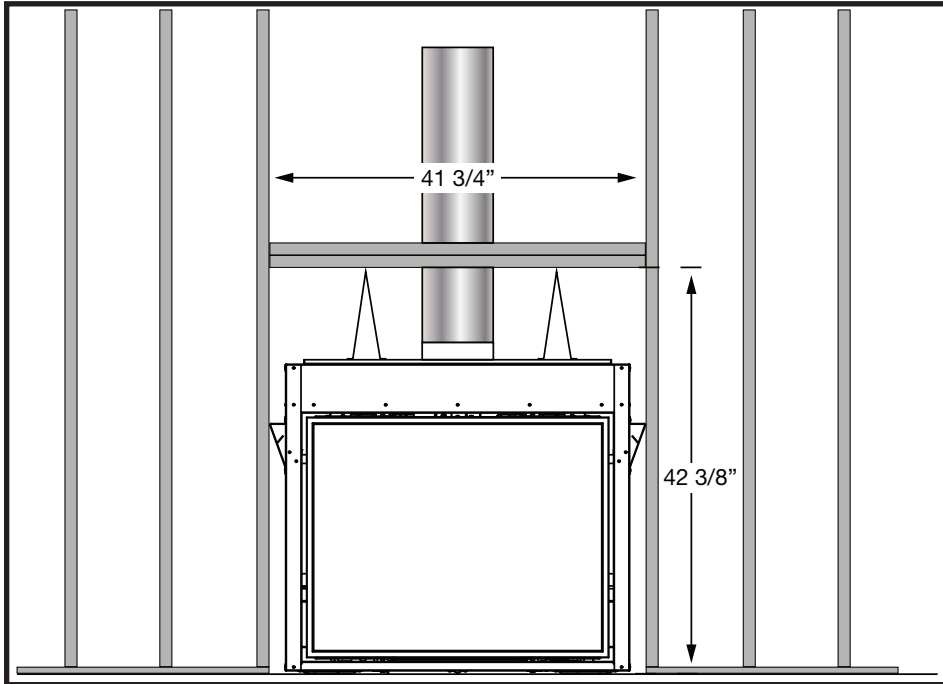

Figure 5: Framing front view.

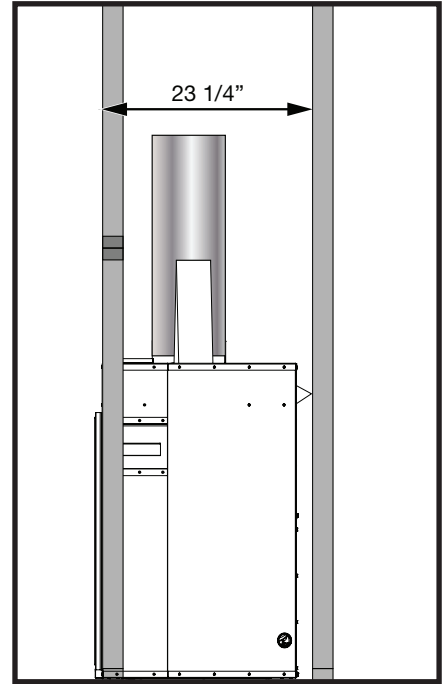

Figure 6: Right side view.

Note: Position of bottom of the header should be parallel with the top of the stand-offs (Figure 5).

Framing in the z35 and Optional Cool Wall Venting Kit

For complete Cool Wall Venting installation instructions, see the installation manual which is included with the Cool Air Venting Kit.

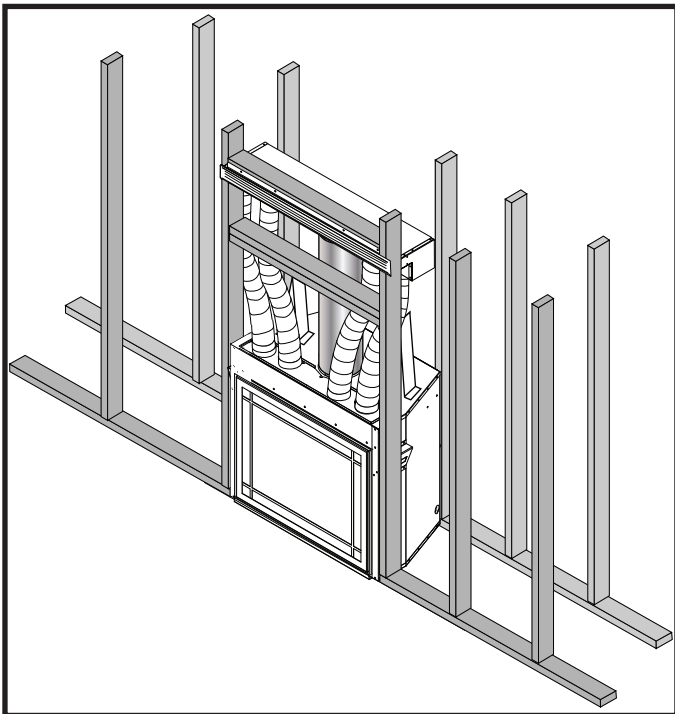

Figure 7: Isometric framing.

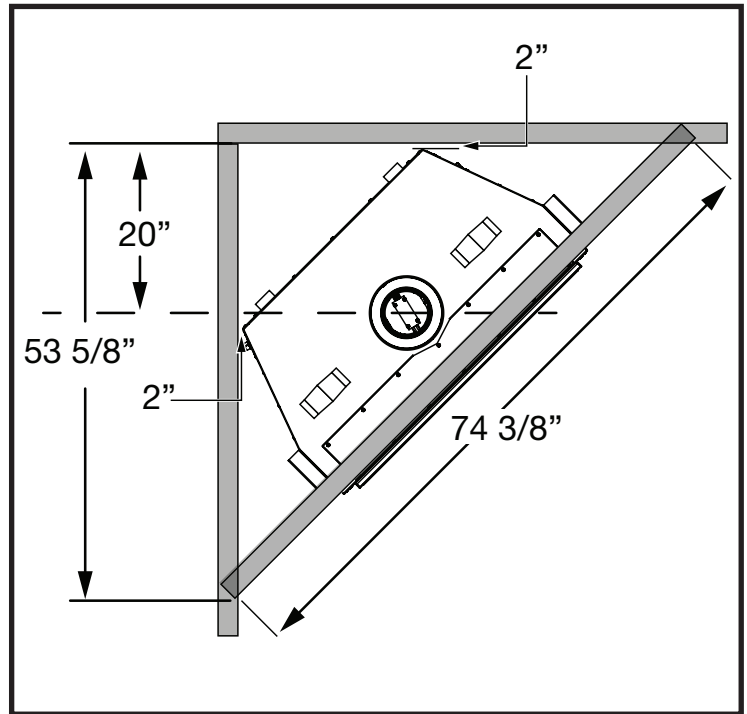

Figure 8: z35 Corner Installation.

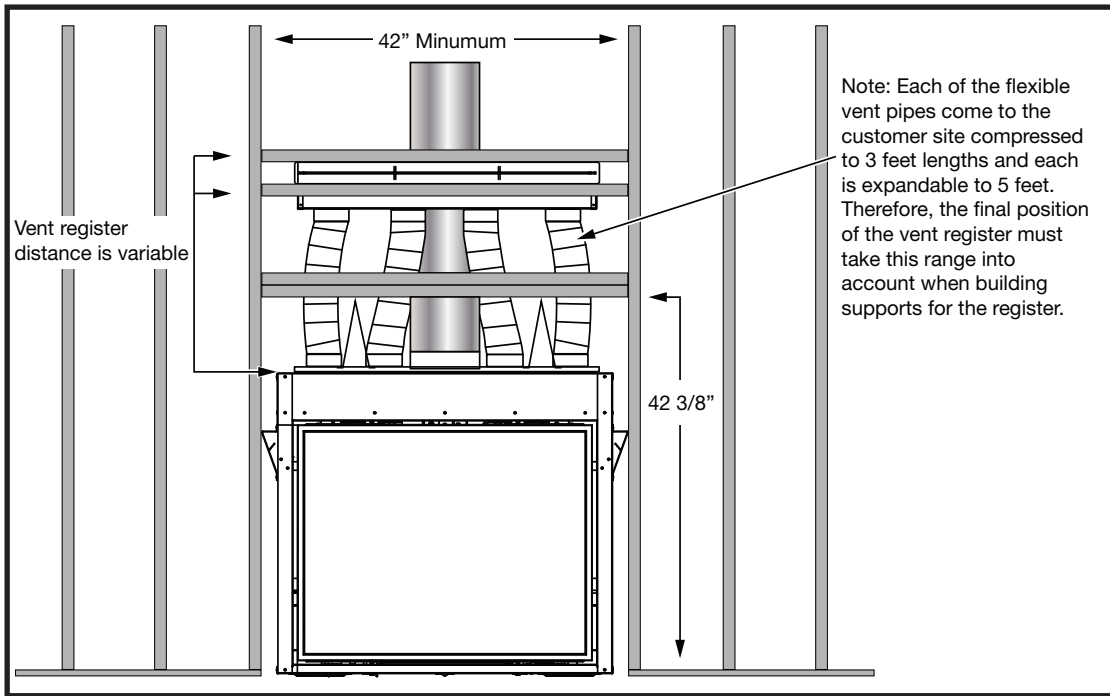

Figure 9: Framing front view with cool wall kit.

NOTE: If using the Cool Wall Vent option, the cool wall vent must be secured by headers above and below the vent (Figure 9).

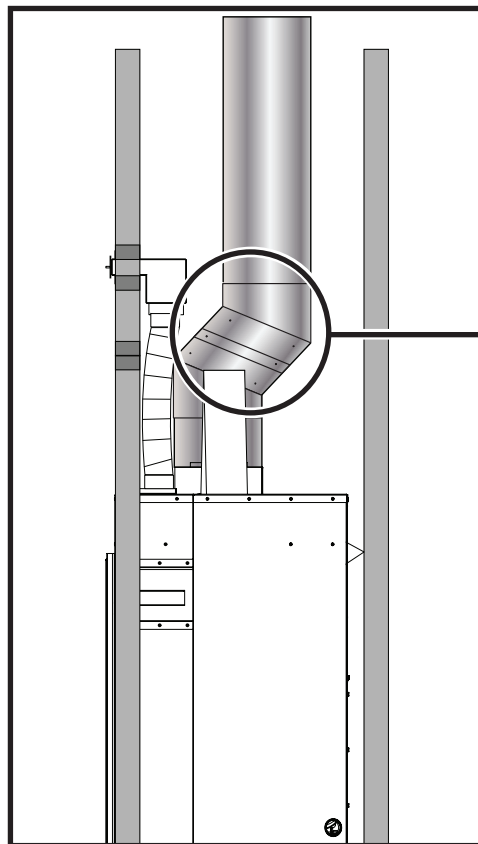

Figure 10: Side view of cool wall kit.

Lower Opening Trim Piece

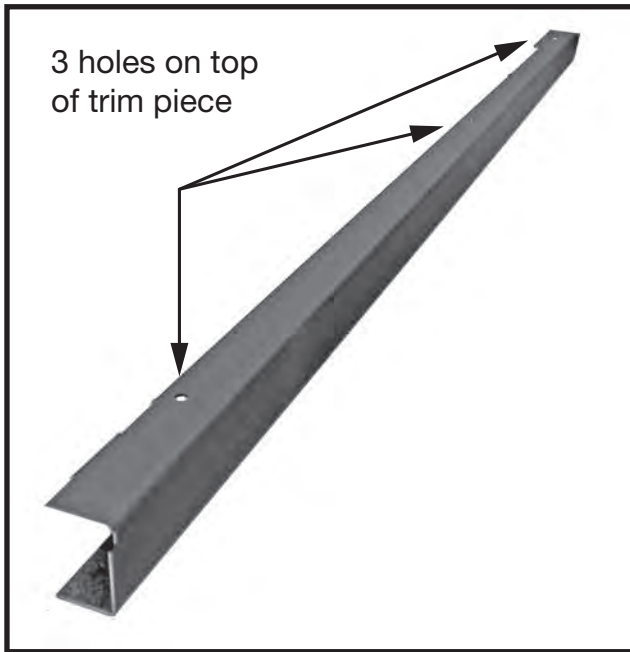

Figure 11: Trim piece.

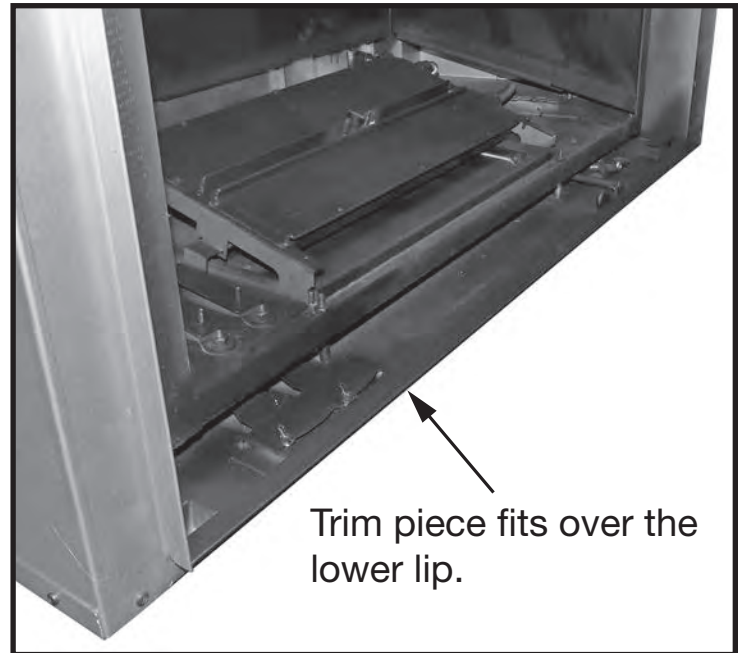

Figure 12: Firebox before trim piece is installed.

If this fireplace is installed directly on a floor as opposed to being installed in an elevated position, a trim piece is provided to cover the space between the lower firebox lip and the floor. Be sure that the 3 holes (these are not screw holes) in the trim piece are facing up before installing (Figure 11). This piece snaps on over the lower lip of the firebox (Figure 12). Make sure that the trim piece is firmly seated on top of the lower firebox lip (Figure 13).

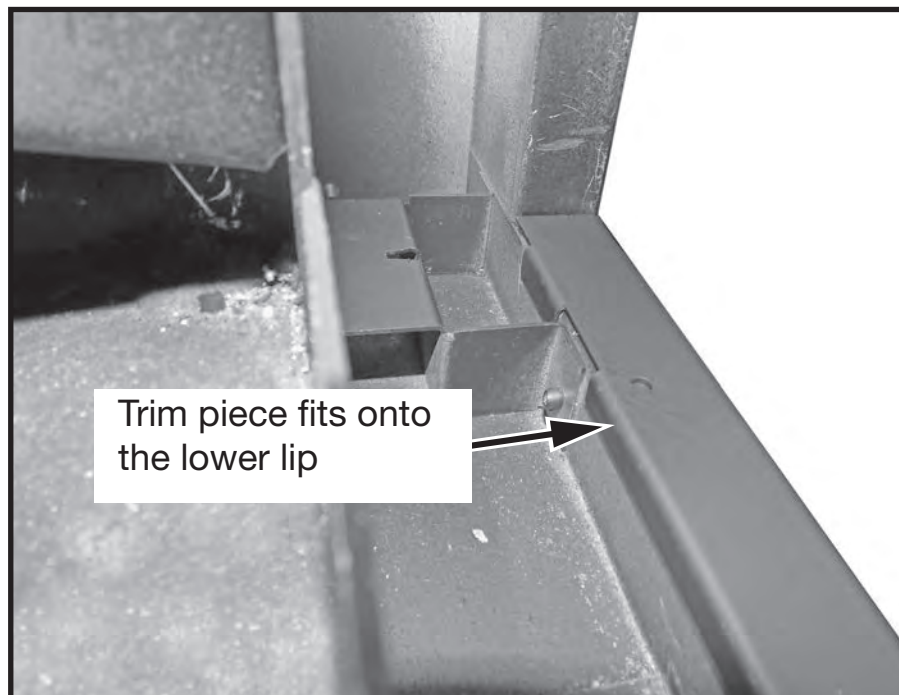

Figure 13: Trim piece seated on lower lip.

Clearances to Combustibles

Standard Configuration

Mantel Depth / Mantel Height (from floor)
1" / 36"
6" / 42"
9" / 48"
Hearth Clearance
0"
Objects in front of Appliance
36"
Under Appliance
0"
Clearance to exposed sidewall
20" from center of window
Ceiling to top of front surround
36" Minimum

Cool Wall Kit Configuration

Mantel Depth / Mantel Height (from floor)
1" / 32"
6" / 32"
9" / 32"
Hearth Clearance
0"
Objects in front of Appliance
36"
Under Appliance
0"
Clearance to exposed sidewall
20" from center of window
Ceiling to top of front surround
36" Minimum

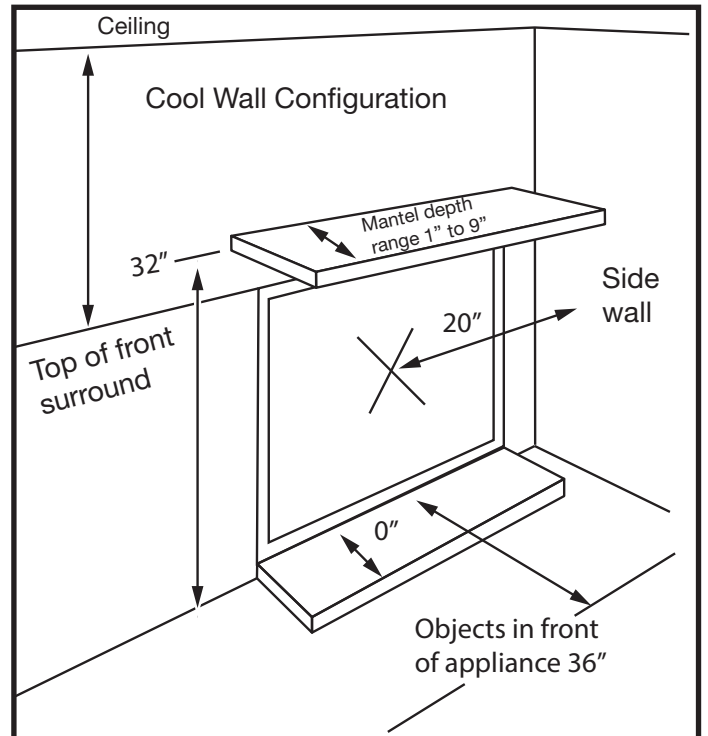
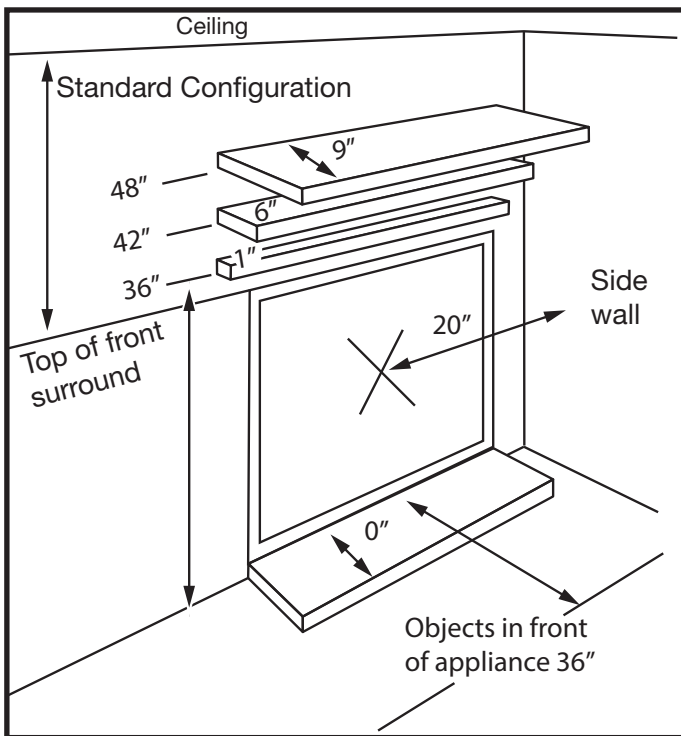

Figure 14: Standard clearances to combustibles.

Figure 15: Cool Wall clearances to combustibles.

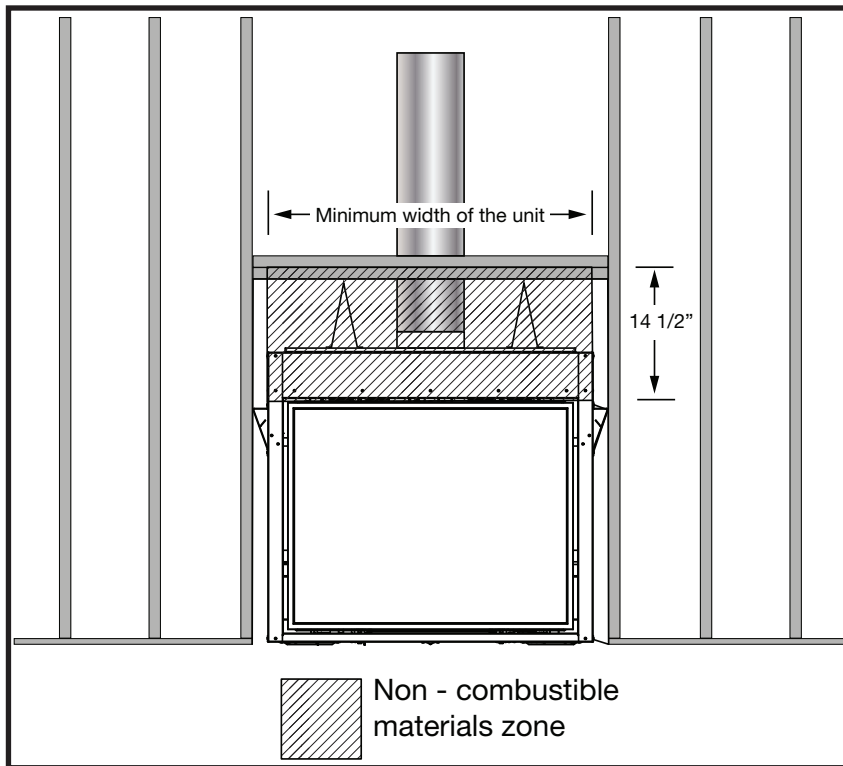

Figure 16: Combustible and non-combustible zones front view.

When framing and finishing in the z35, there are 2 zones that the installer must consider: combustible materials zone and non-combustible materials zone. Building materials in the non-combustible materials zone can utilize dry-wall or other combustible facing materials. Building materials in the non-combustible zone must use non-combustible materials and insulation.

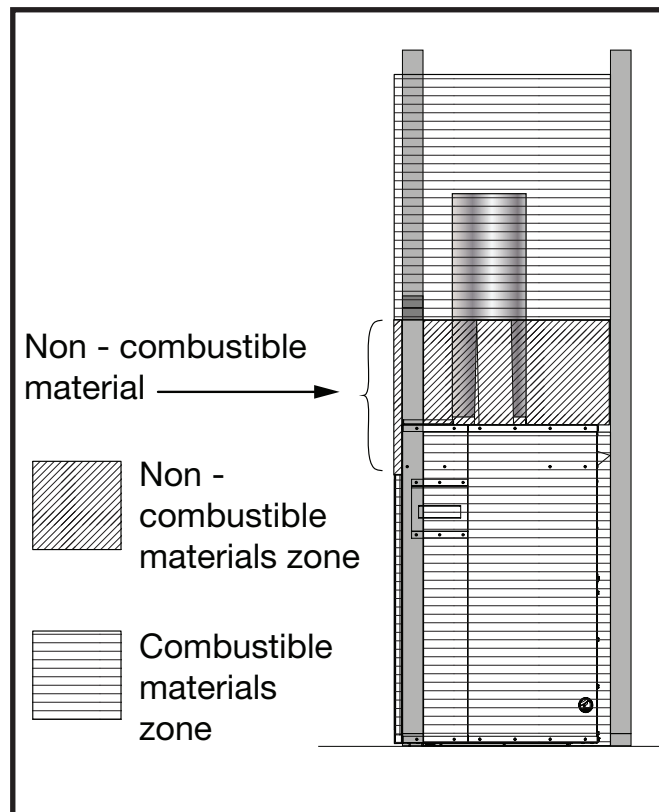

Figure 17: Combustible and non-combustible zones side view.

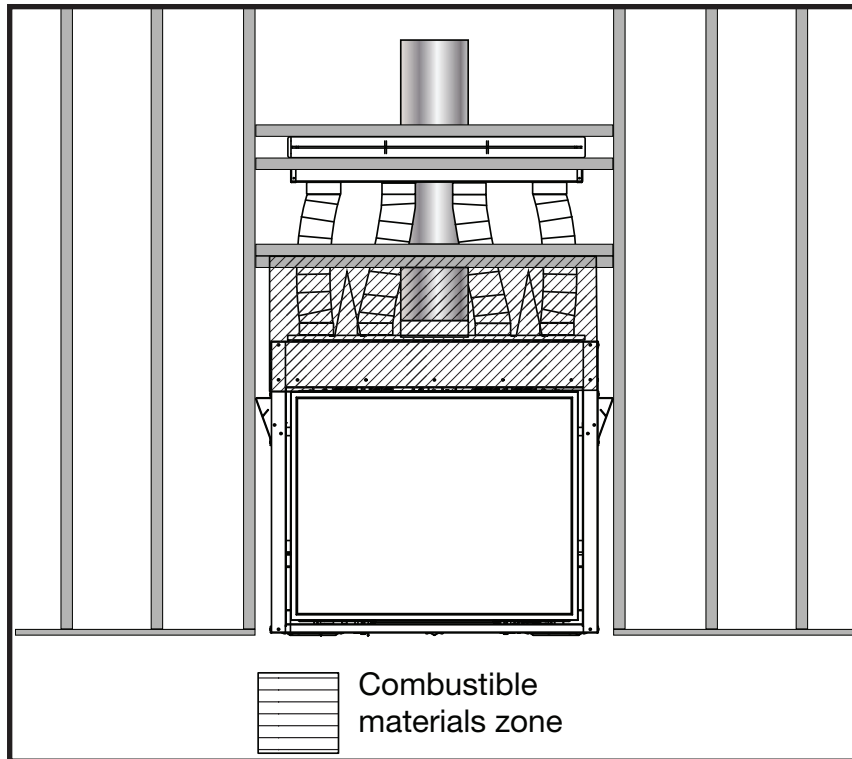

Figure 18: Combustible and non-combustible side view with cool wall kit.

For installations using the optional cool wall kit, the combustible and non-combustible zones remain the same as units not using the cool wall kit.

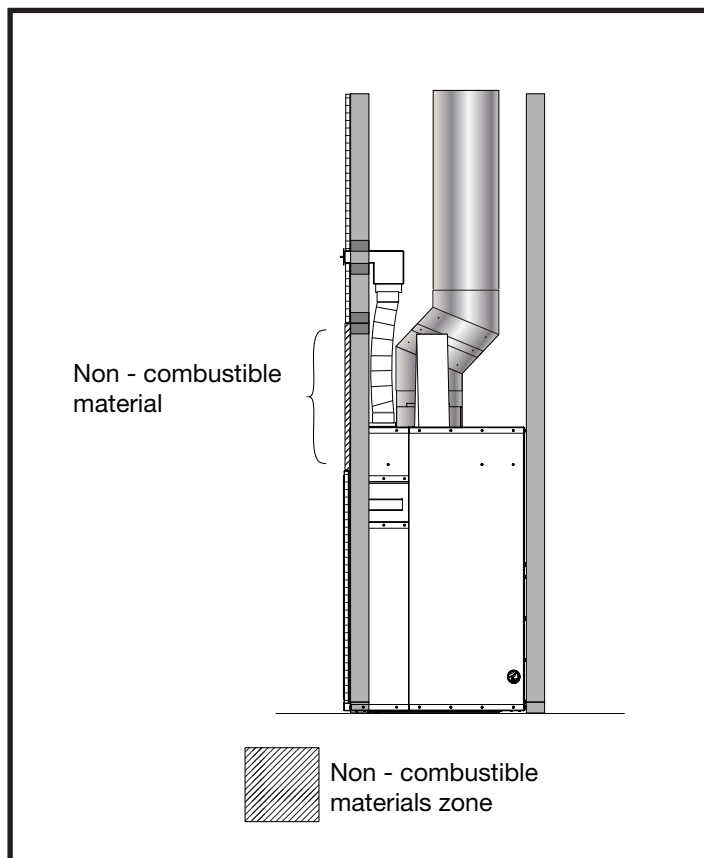

Figure 19: Sideview with cool wall kit.

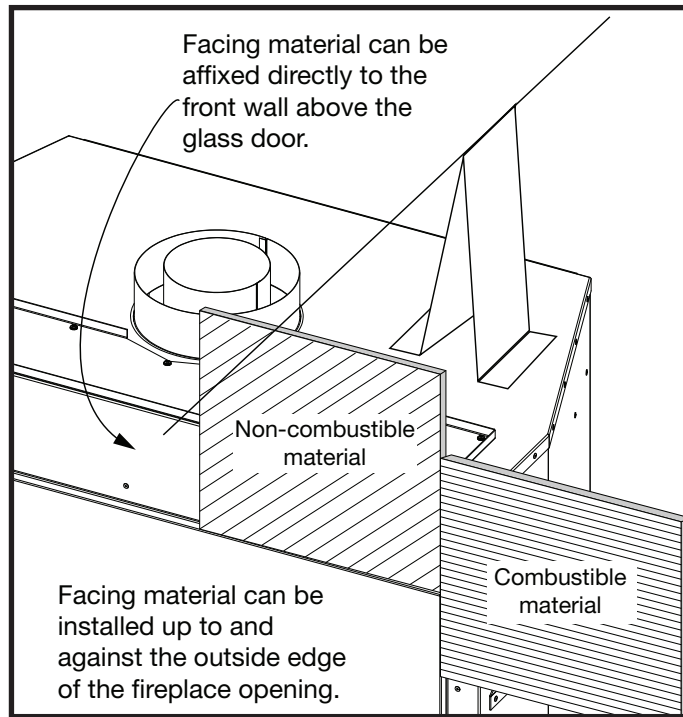

Figure 20: Combustible and non-combustible zones details.

Combustible facing material may be butted up to, and against the side edges of the fireplace opening except for the area directly above the fireplace opening (Figure 20). Only non-combustible material may be used in this area.

Combustible facing material may be used to finish the Cool Wall Kit (Figure 21) as long as the material does not encroach on the non-combustible zone. (Figure 16).

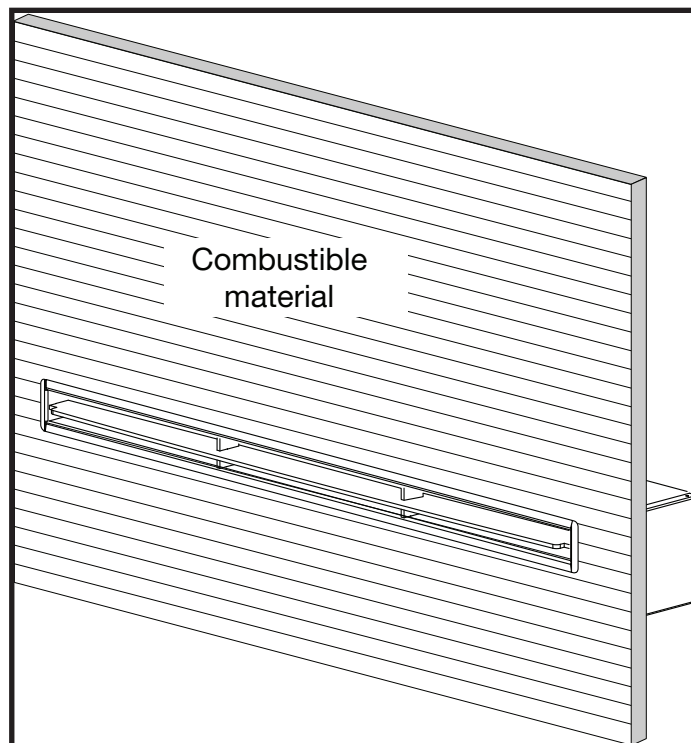
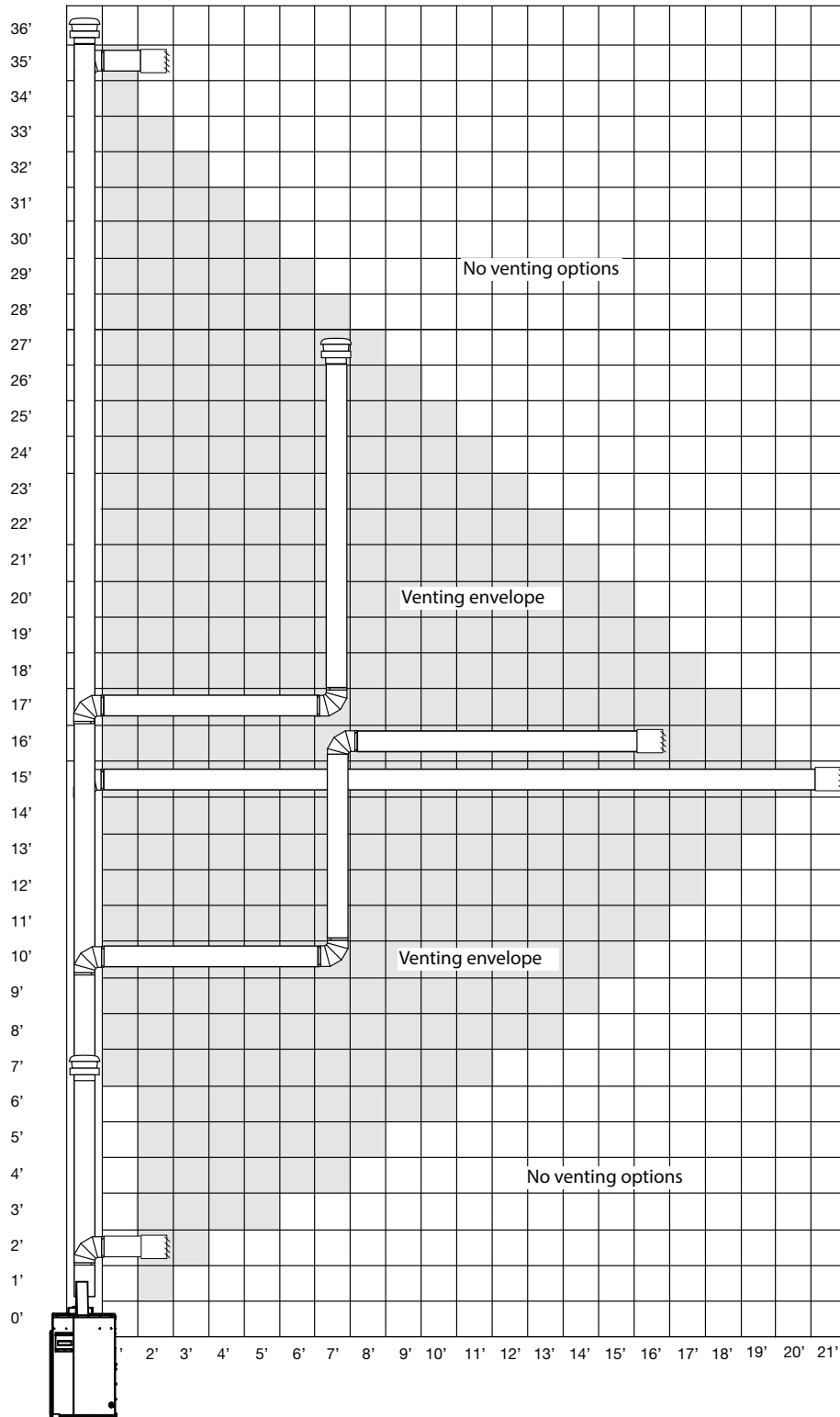

Figure 21: Cool wall vent and facing material.

Venting Chart



Note: The vent must not exceed a total length of 35 feet. Any combination of rise and run may be used but must be constrained to the boundaries of this chart. A Maximum of three 90° elbows may be used. Only one (1) 90° elbow or combination of other elbows equaling 90° can be used without reducing horizontal run. For each additional 90° elbow, or an equal combination of elbows, reduce horizontal vent run by 2 feet. Ensure vent pipe is properly supported.

Vent Terminal Minimum Clearances

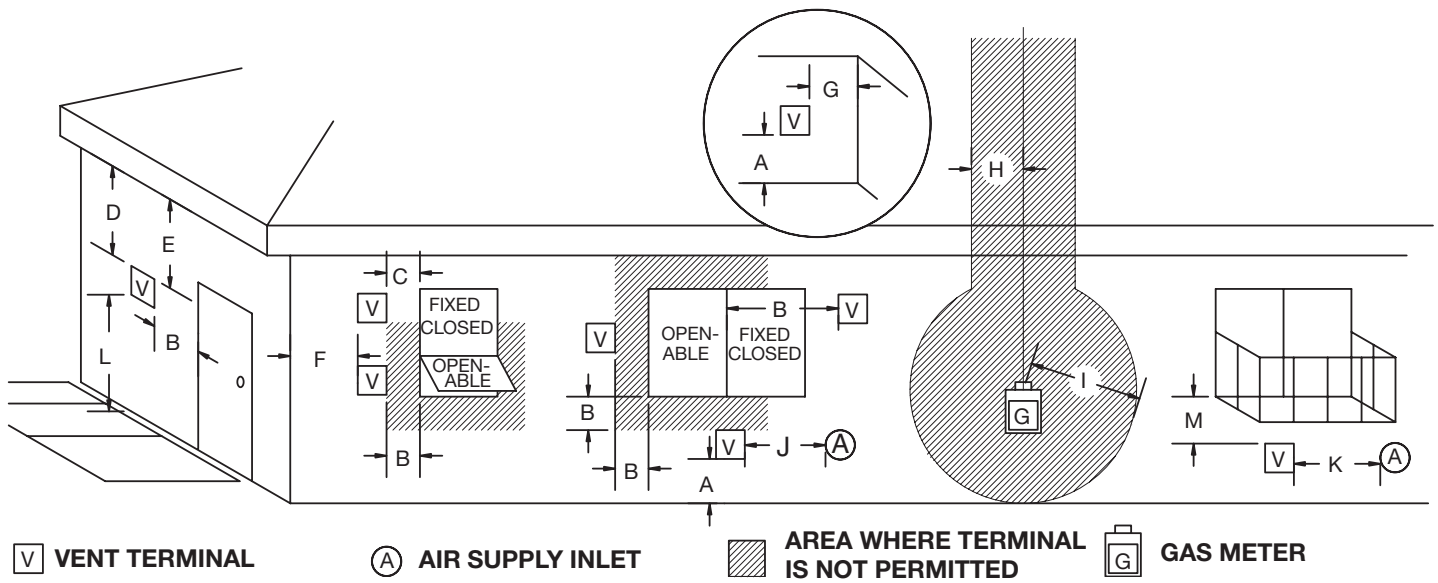

A=	*12 inches (30 cm) min.	Clearances above grass, top of plants, wood, combustible veranda, porch, deck, or balcony.
B=	*12 inches (30 cm) min.	Clearance beside or below a window or door that may be opened.
C=	12 inches (30 cm) min.	Clearance to permanently closed window recommended to prevent condensation on window.
D=	16 inches (40 cm) min.	Vertical clearance to ventilated soffit located above the terminal within a horizontal distance of 16 inches (40 cm) .
E=	16 inches (40 cm) min.	Clearance to unventilated soffit.
F=	6 inches (15 cm) min.	Clearance to outside corner.
G=	6 inches (15 cm) min.	Clearance to inside corner.
H=	3 feet (90 cm) min.	*Not to be installed above a meter/regulator assembly within 3feet (90 cm) horizontally from the center-line of the regulator.
I=	*6 feet (1.8 m) min.	Clearance to service regulator vent outlet.
J=	*12 inches (30 cm) min.	Clearance to non mechanical air supply inlet to building or the combustion air inlet to any other appliance.
K=	*6 feet (1.8 m) min.	Clearance to a mechanical air supply inlet.
L=	*7 feet (2.1 m) min.	^ Clearance above paved side-walk or a paved driveway located on public property
M=	**16 inches (40 cm) min.	Clearance under veranda, porch, deck, or balcony

^ a vent shall not terminate directly above a side-walk or paved driveway which is located between two single family dwellings and serves both dwellings*
 ** only permitted if veranda, porch, deck, or balcony is fully open on a minimum of 2 sides beneath the floor*
 * as specified in CGA B149 Installation Codes, Note: local Codes or Regulation may require different clearances
 * for U.S.A. Installations follow the current National Fuel Gas Code, ANSI Z223.1



This fireplace is certified for use with 5" x 8" coaxial venting components only. It is permitted to only use certified venting for this appliance.

Venting Configuration

Horizontal venting may be supported by non - combustible supports. There must be a minimum of 3" from the venting and any Combustible material.

Fire stops must be used wherever the venting material passes through a wall, floor or ceiling.

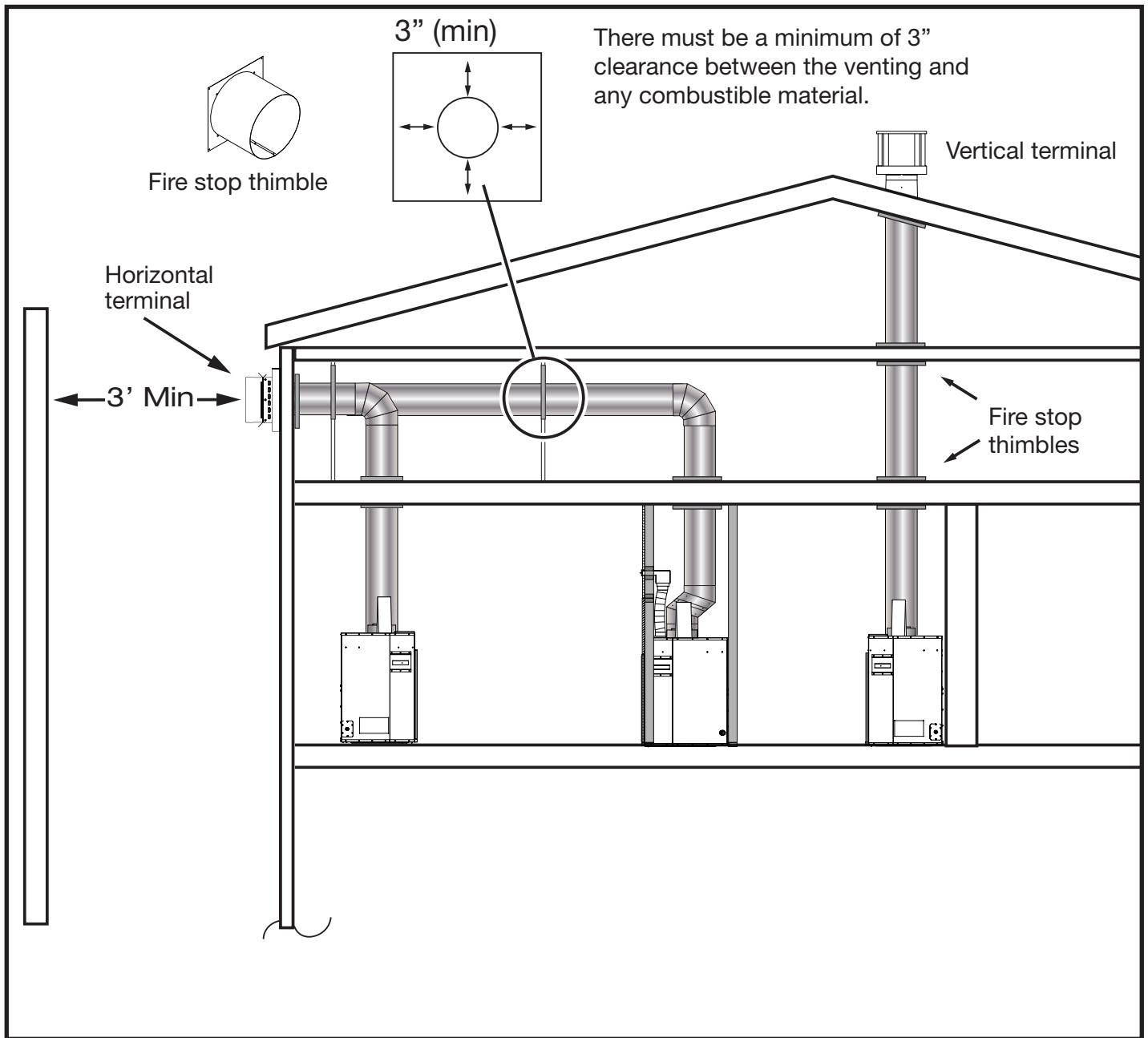

Figure 22: z35 Venting configurations.

Vertical Termination

Vertical Termination using a Duravent Terminal



Figure 23: Duravent 58dva-vch vertical terminal.

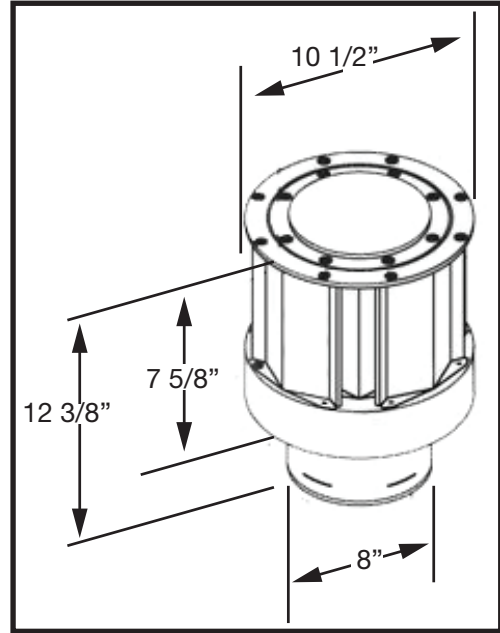

Figure 24: 58DVA-VCH Terminal dimensions.

Vertical termination can use either a Duravent 58DVA-VCH Vertical Terminal or an ICC TM-5 SVT Vertical Terminal. No other vertical terminals are approved for use with this fireplace.

NOTE: Mixing venting components from different manufacturers is inadvisable.

Vertical Termination using an ICC Terminal



Figure 25: ICC TM-5 SVT.

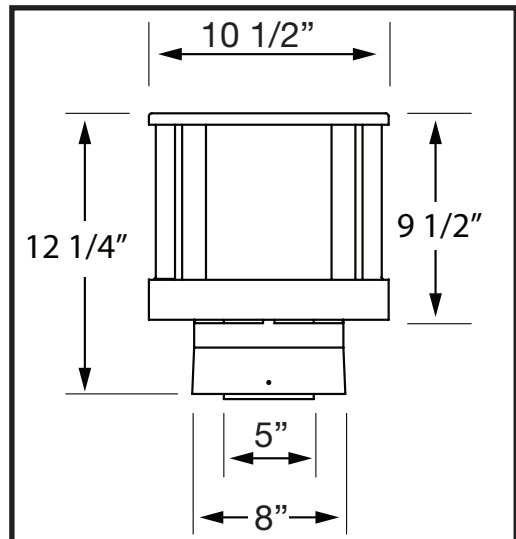

Figure 26: ICC TM-5 SVT Vertical terminal dimensions.

Horizontal Termination

Horizontal Termination using a Duravent Terminal



Figure 27: Duravent 58DVA-HSCH Horizontal terminal.

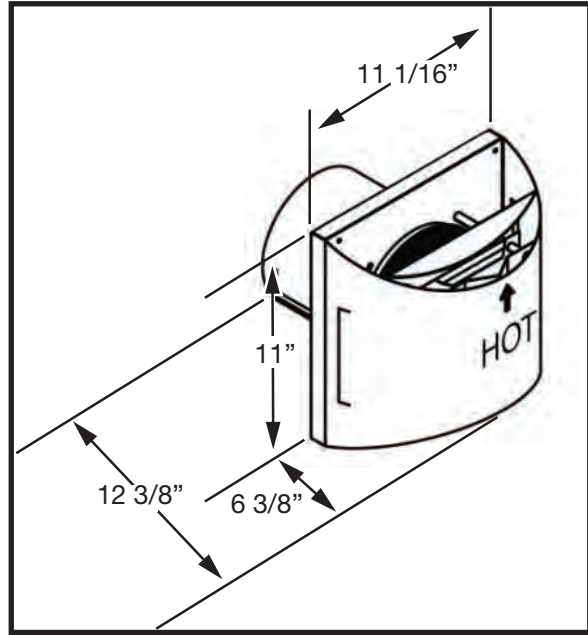

Figure 28: Duravent 58DVA-HSCH Horizontal terminal.

Horizontal termination can use either a Duravent 58DVA-HSCH Horizontal Terminal or an ICC TM-5HT Horizontal Terminal. No other horizontal terminals are approved for use with this fireplace.

NOTE: Mixing venting components from different manufacturers is inadvisable.

Horizontal Termination using an ICC Terminal



Figure 29: ICC TM-5HT Horizontal terminal.

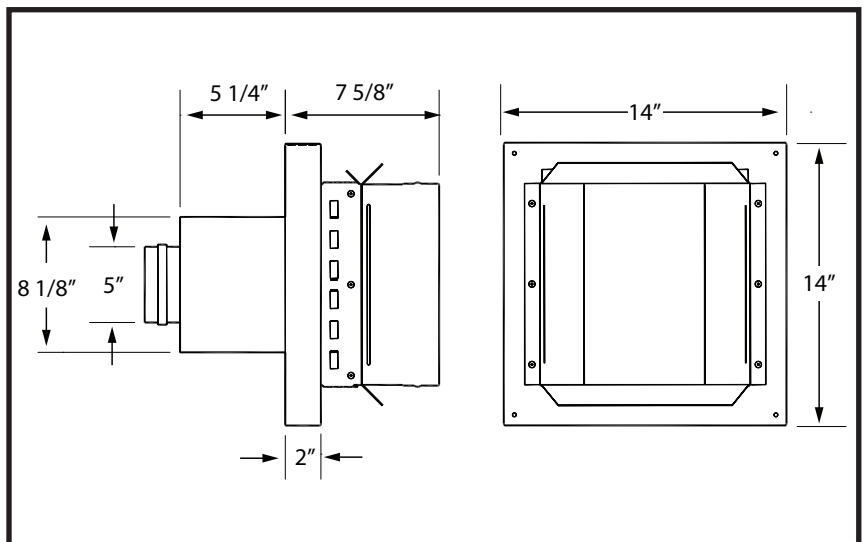
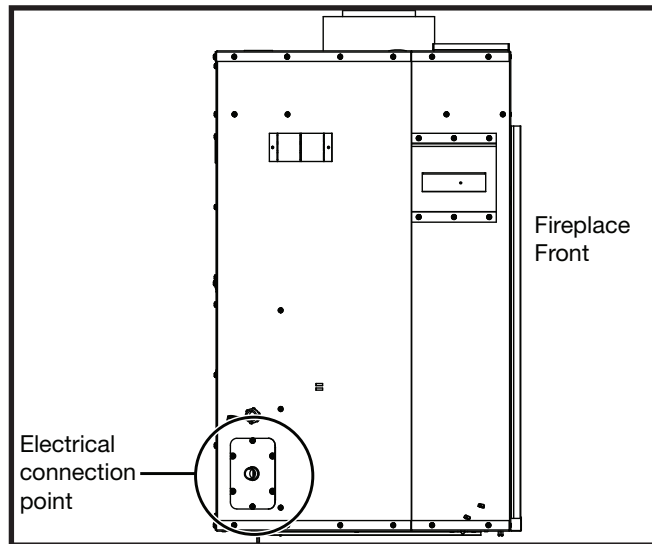

Figure 30: ICC TM-5HT Horizontal terminal dimensions.

Electrical Connection

Electrical connection

The power supply to this fireplace is to be hard-wired in using marrets. Open the access cover plate located on the left-hand side of the fireplace (Figure 31) and connect the customer supplied line to the wires inside the junction box using marrets (Figure 32). Ground wire must be connected to the Ground Post (Figure 32) in the electrical connection box. Electrical connections should be performed by a qualified electrician as per local electrical codes.



Note: See rating label on unit or on rating label copy shown on page 55 for electrical rating.

Figure 31: Electrical connection point.

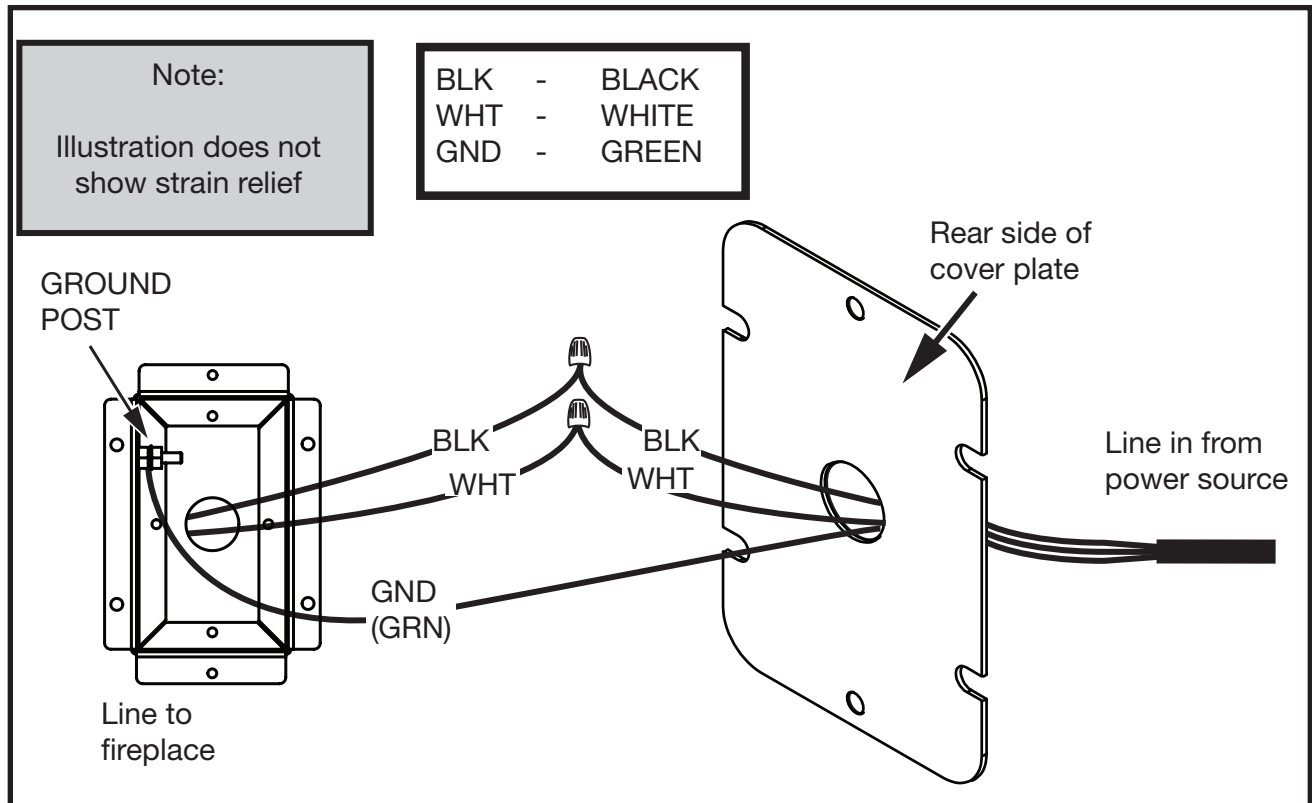

Figure 32: Z35 wiring instructions.

Wall Switch Installation

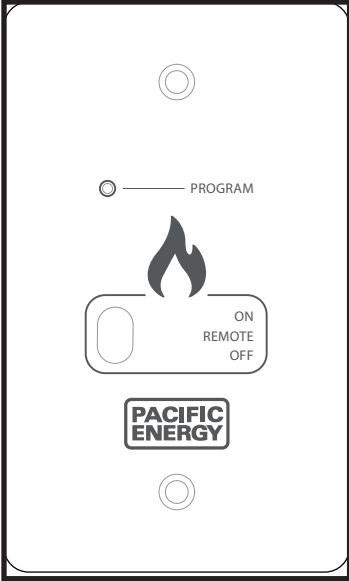

Figure 33: SIT Wall switch plate.



Figure 34: Wall switch - battery side.



Figure 35: Wall switch - interface side.

The control Unit comes pre-wired with the exception of the CAT 5 cable and the wall switch . This CAT 5 cable will extend from the wall switch to the control module located at the rear of the fireplace (Figure 36). The cable must be plugged into the wall switch at the “OUT TO FIREPLACE” port as shown in Figure 35. Installing batteries into the wall switch ensures that the fireplace can be operated even in the case of a power outage. Install four “AA” batteries in the wall switch before it is secured to the wall (Figure 34).

If the wall switch is being connected to a Home Automation system, two cables will be used; the top cable will go from the wall switch to the fireplace and the bottom cable will go from, the wall switch to the Home Automation system.

If not using a Home Automation system, only the upper cable will be used to go from the wall switch to the fireplace.

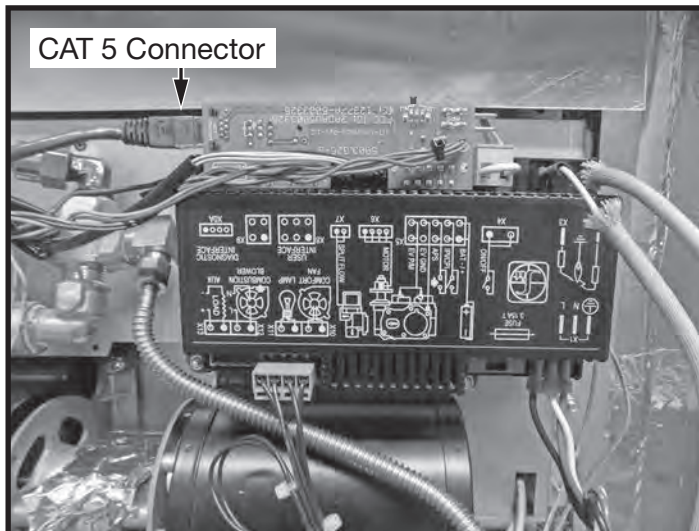

Figure 36: SIT Module and CAT 5 Connection.

Home Automation

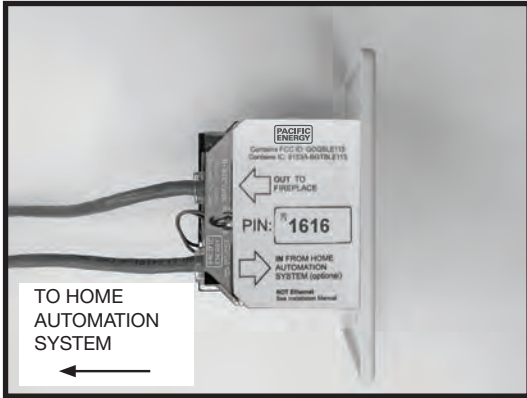

Figure 37: Complete communication wiring.

The home automation feature supplied with this fireplace is capable of controlling the flame and light on/off function with the use of a dry contact relay common to home automation systems. Furthermore, the flame and light level may be modulated from high to low using the 0 - 10 volt analog output available on most home automation systems.

Figure 38 shows the wire designations required to connect the fireplace to a home automation system.

Note: Leave the wall switch on the “Remote” setting when using home automation.

NOTE:

When a signal has been supplied by the home automation system, the fireplace control will repeat the signal every 2 hours or until a new command has been received.

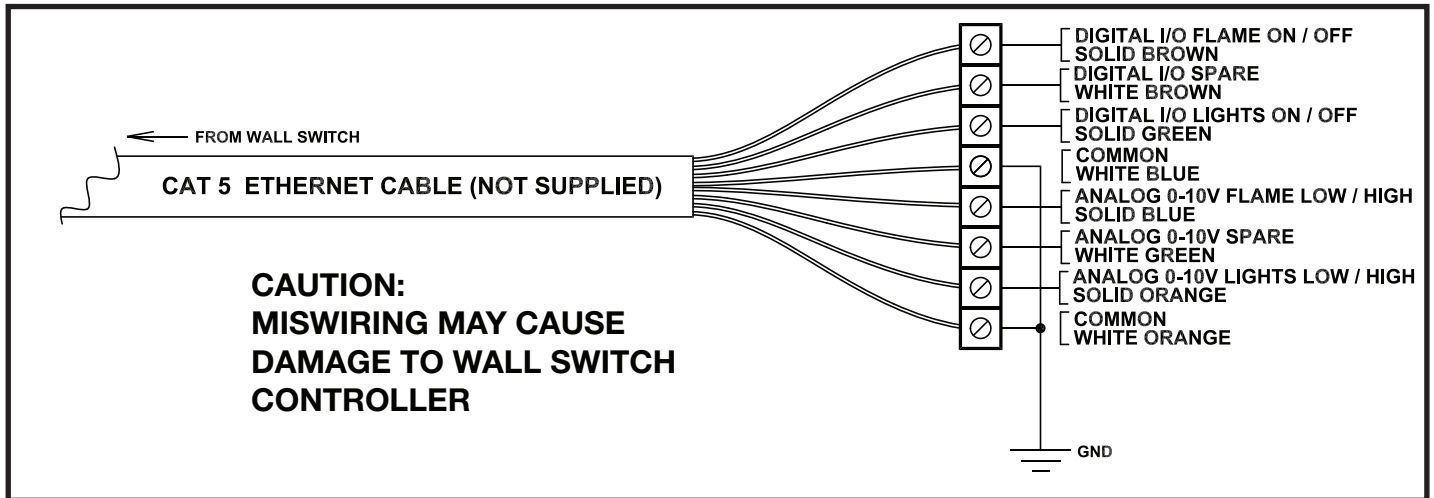

Figure 38: Home automation wiring diagram.

NOTE:

- Digital I/O must be connected to a dry contact relay.
- Analog flame and light input through 0 - 10 volt DC signal scaled as follows:

Low = 1 volt
High = 10 volts

Control Overview

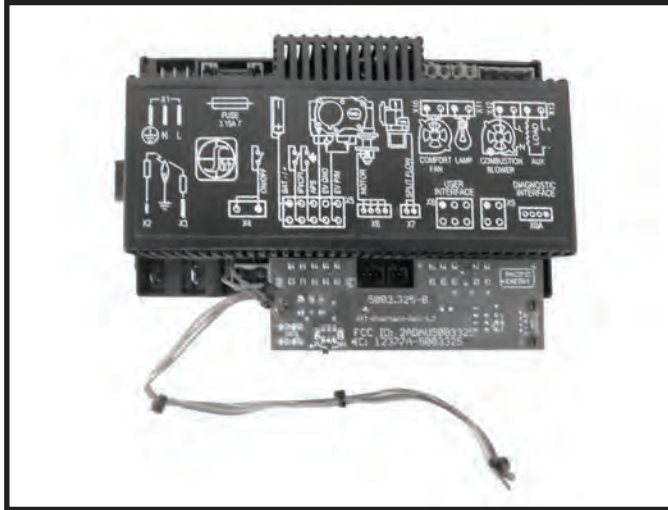

Figure 39: SIT Proflame controller module.



Figure 40: Proflame - SIT remote control device.

The Proflame controller (Figure 39) is used along with the Proflame gas valve (Figure 41). The use of the Proflame controller requires a remote control device (provided) unique to the Proflame configuration (Figure 40). Instructions for using the Proflame remote control device are found in the z35 operating Instructions manual. The wall switch uses 4 AA batteries. The Proflame remote control unit uses 3 AAA batteries.

Gas Valve for Configuration

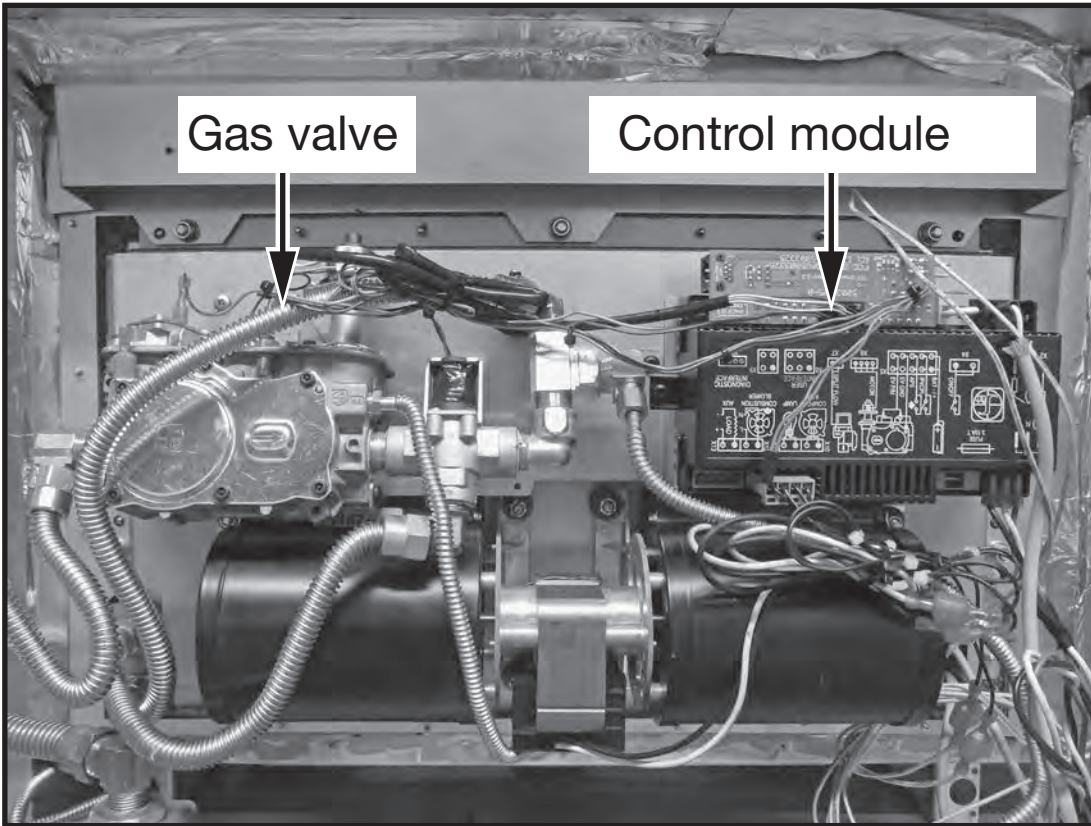

Figure 41: SIT Control panel.

Gas valve and control module

The gas valve assembly and the control module are mounted onto a panel which is located on rear wall. Access to this panel and its' components can be found in "Control Panel Removal / Installation" on page 46.

Gas Connection

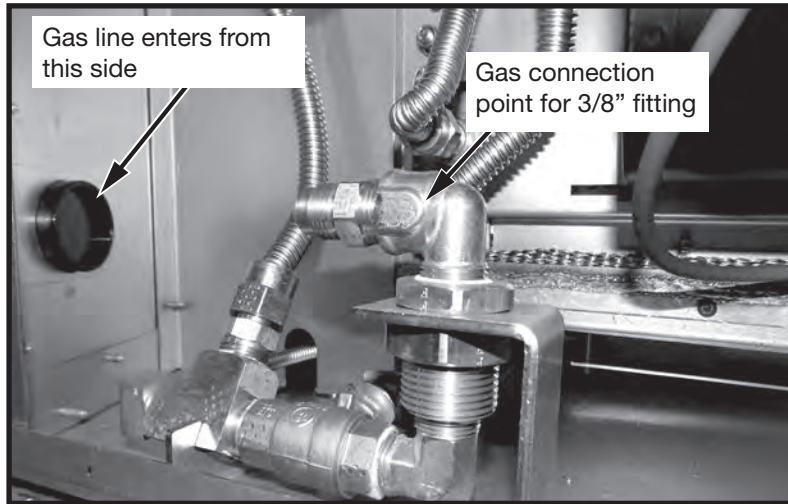

Figure 42: Gas connection point.

Gas connection

To make the required gas connection, start by positioning the gas fireplace. Connect a gas line with a 3/8" connector to the gas elbow point as shown in Figure 42. Apply thread sealer to the 3/8" fitting before attaching.

A gas shut off valve handle is located at the lower right-hand corner of the fireplace, in front of the glass door. The valve is shut off when handle is in the up position (Figure 43) and down when in the on position (Figure 44) To be able to insert or remove the glass door, the gas valve will need to be in the open position.

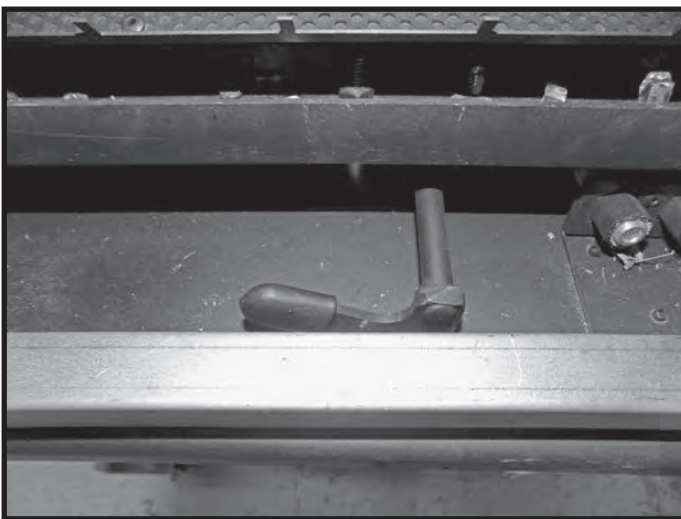

Figure 43: Gas valve in open position.

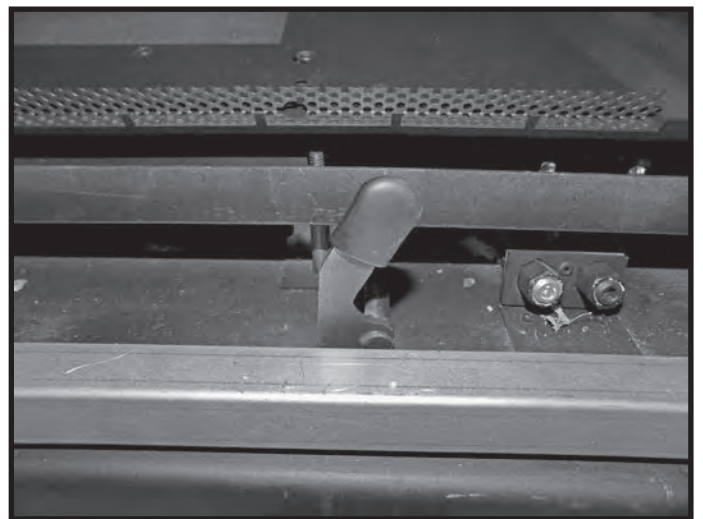

Figure 44: Gas valve handle in closed position.

Gas Supply

Servicing of the appliance can be performed from the front of the unit.

Caution: The gas line should be installed by a qualified service person in accordance with all building codes. This section is intended as a guide for qualified technicians installing this appliance. Consult local and/or national building codes before proceeding.

- Gas supply line connection is located on the right side of the fireplace. Gas connection accepts a 3/8" NPT fitting. Correct gas line diameter must be used to assure proper operation and pressure.
- The fireplace input rating is shown in the chart below.
- A drip leg must be installed in the gas supply line going to the gas control valve to minimize the possibility of any loose scale or dirt within the gas supply line from entering the control valve.

Check local codes for additional requirements.

Turn on the gas supply and check that all connections are tight and leak free.

WARNING: The gas tray including gasket must be reinstalled after conversion/installation or servicing has been completed.

Gas Pressure Check

Please refer to See "Gas Pressure Testing Procedure" on page 29 for gas pressure testing procedure.

Gas pressure requirements		
Input Pressure	Natural Gas	Propane
Minimum	5.0" WC	12.5" WC
Maximum	13.9" WC	13.9" WC
Manifold Pressure		
High	3.5" WC	10" WC
Low	1.6" WC	6.4" WC

z35

<u>Gas</u>	<u>Orifice</u>	<u>Output</u>
NG	Front EF	35,000 btu/hr (Max) / 9,000 btu/hr (Min)
NG	Rear EG	
LP	Front EJ	26,000 btu/hr (Max) / 7,500 btu/hr (Min)
LP	Rear EK	

Gas Pressure Testing Procedure

Note: To test the gas pressure, turn off the gas supply to the appliance before loosening test point screws.

Verify gas pressures with the fireplace lit and at the highest setting.

1. Remove window surround and locate the valve.
2. Turn gas off using gas valve handle as shown in Figure 45.
3. Locate the inlet and outlet test ports which are located on the right hand side of the fireplace (Figure 45). After locating test ports, loosen the screws within the ports using a 3/8" Allen key.
4. Attach pressure gauge to the test ports
5. Turn gas supply back on and test pressures.
6. After testing is finished turn off gas supply, remove the pressure gauges and tighten up the screws in the test points.

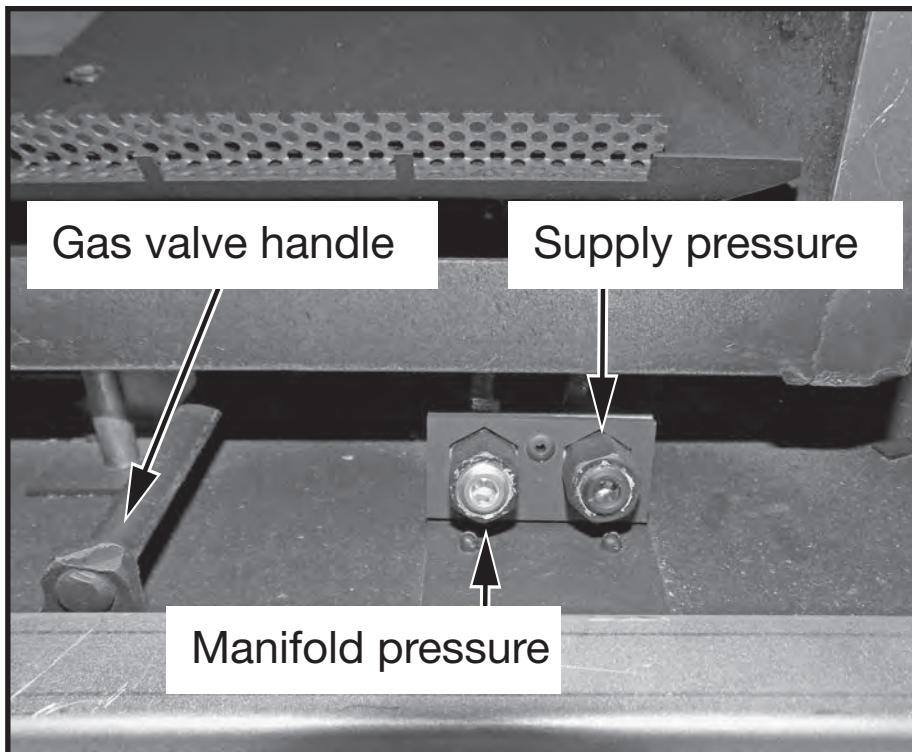

Figure 45: Gas pressure testing ports.

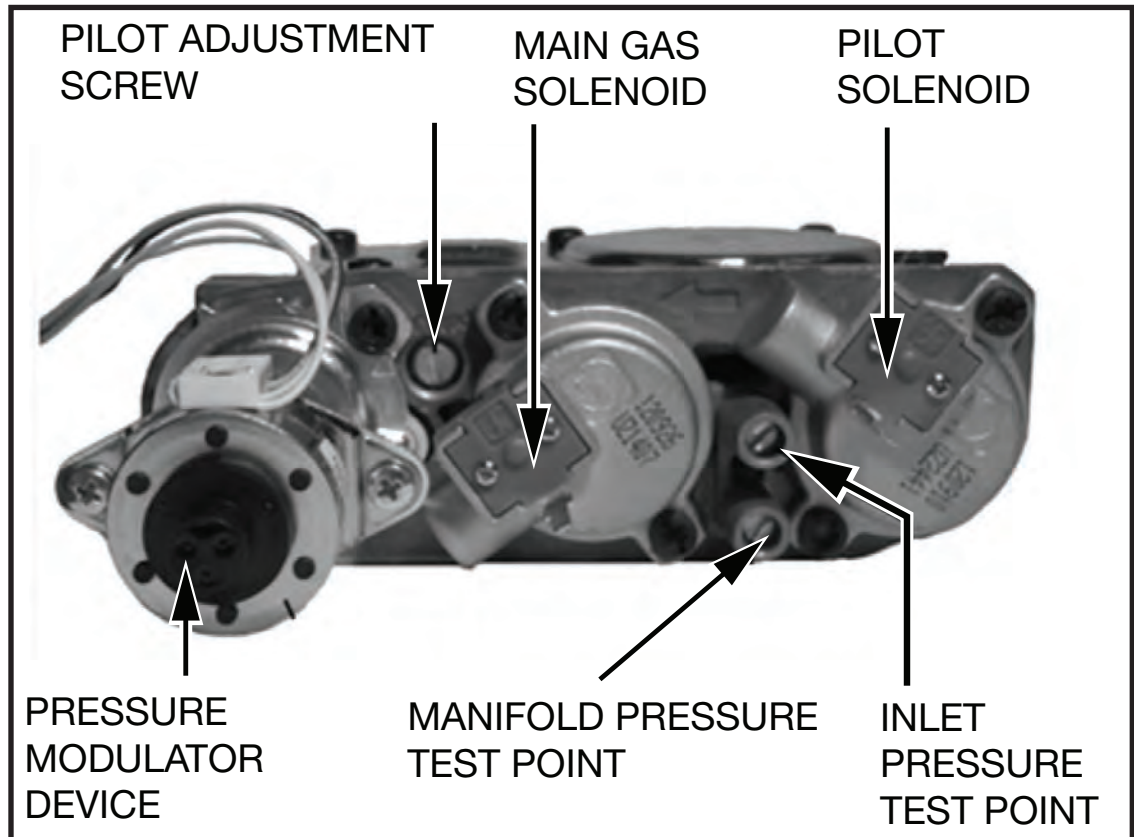

Figure 46: SIT gas control valve.

Gas Leak Detection

A gas leak sniff test should be performed after a gas connection, gas valve or pilot assembly has been replaced or serviced. There are many different makes and models of detectors. A unit which can detect natural gas and propane must be used. Follow the gas leak detector manufacturers instructions on how to properly use the detector.

CAUTION: The electrical power to the fireplace should be disconnected at the circuit breaker before and during any gas valve or gas connection servicing or replacement. Do not reconnect the electrical power to the fireplace until after the gas leak detection test has been completed and the presence of a gas leak has been ruled out.

Lighting Instructions

FOR YOUR SAFETY READ BEFORE LIGHTING

WARNING: If you do not follow these instructions exactly, a fire or explosion may result causing property damage, personal injury or loss of life.

- A. This appliance is equipped with an ignition device which automatically lights the pilot. Do not try to light the pilot by hand.
B. BEFORE LIGHTING smell all around the appliance area for gas. Be sure to smell next to the floor because some gas is heavier than air and will settle on the floor.

WHAT TO DO IF YOU SMELL GAS:

- Do not try to light any appliance.
- Do not touch any electric switch; do not use any phone in your building.

- Immediately call your gas supplier from a neighbour's phone. Follow the gas supplier's instructions.
 - If you cannot reach your gas supplier, call the fire department.
- C. Use only your hand to push in or turn the gas control knob. Never use tools. If the knob will not push in or turn by hand, don't try to repair it, call a qualified service technician. Force or attempted repair may result in a fire or explosion.
- D. Do not use this appliance if any part has been under water. Immediately call a qualified service technician to inspect the appliance & to replace any part of the control system & any gas control which has been under water.

LIGHTING INSTRUCTIONS

1. STOP! Read the safety information above on this label.
2. This appliance is equipped with an ignition device which automatically lights the pilot. Do not try to light the pilot by hand.
3. Push the "On/ Off" switch to turn the fireplace ON.
 - If the burner does light go to step 6.
 - If the burner does not light, complete steps 4 through 5.
 - If the burner will not light or stay lit after several tries, push the "On/ Off" switch for the fireplace to OFF, turn off all electric power

to the fireplace and call your service technician or gas supplier.

Note: Sufficient time must be allowed for air to escape from lines if the unit is being lit for the first time.

4. Push the "On/ Off" switch to the fireplace Off.
5. Allow sufficient length of time (minimum 5 minutes) for any gas in the combustion chamber to escape. If you still smell gas, STOP! Follow "B" in the safety information above on this label. If you don't smell gas, go to step 3.
6. Set fireplace to desired setting by using hand held remote.

TO TURN OFF GAS APPLIANCE

1. Push the "on/ off" switch to the "Off" position.

2. Turn off all electric power to the appliance and remove backup batteries if service is to be performed or for extended shutdown.

Due to high surface temperatures, keep children, clothing and furniture away. Keep burner and control compartment clean. See installation and operating instructions accompanying the appliance.

A cause de la température élevée des parois, tenir éloignés les enfants, les vêtements et les meubles. Maintenir propres le brûleur et le compartiment de commande. Voir les instructions relatives à l'installation et au fonctionnement qui accompagnent l'appareil.

CAUTION: Hot while in operation. Do not touch. Severe burns may result. Keep children, clothing, furniture, gasoline and other liquids having flammable vapours away. Keep burner and control compartment clean. See installation and operating instructions accompanying the appliance.

ATTENTION: L'appareil est chaud lorsqu'il fonctionne. Ne pas toucher l'appareil. Risque de brûlures graves. Surveiller les enfants. Garder les vêtements, les meubles, l'essence ou autres liquides produisant des vapeurs inflammables loin de l'appareil. S'assurer que le brûleur et le compartiment des commandes sont propres. Voir les instructions d'installation et d'utilisation qui accompagnent l'appareil.

Panel Installation

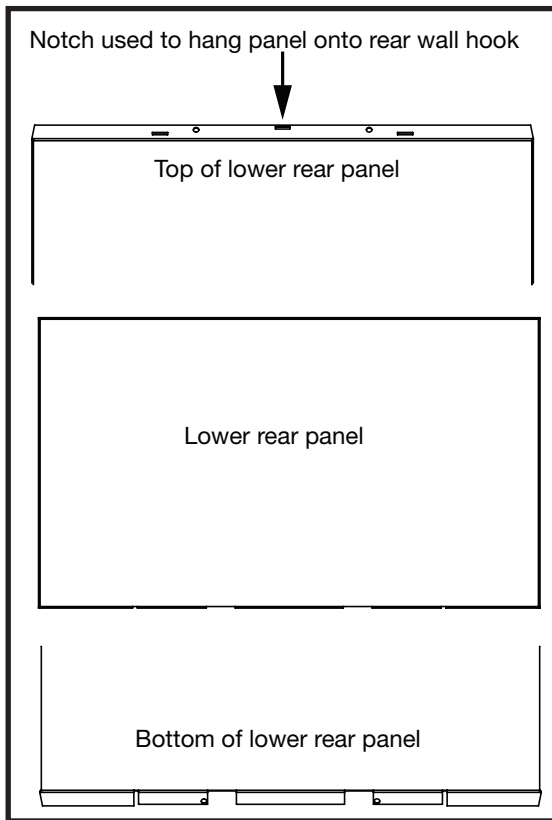

Figure 47: Lower rear panel.

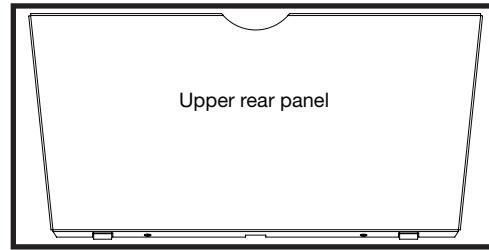

Figure 48: Upper panel.

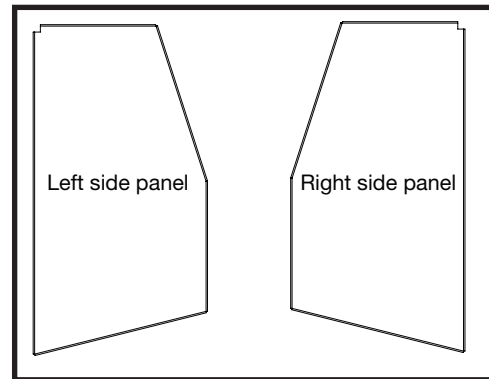

Figure 49: Side panels.



Figure 50: Cross brace.

Installation/Removal

Note: Panels and baffle must be installed before burner tray kit is installed.

1. Remove cross brace (Figure 50) from the upper front of the firebox.
2. Place the lower rear panel against the rear wall and on top of the two supports just behind the burners (Figure 52). Orient this panel so that the center notch is in the up position (Figure 47). This notch will hook onto a tab protruding from the rear wall (Figure 51).
3. Holding the lower rear panel in place, position the upper rear panel so that it is against the rear wall and on top of the lower rear panel (Figure 53). There are two tabs on the bottom of the upper rear panel (Figure 48). These tabs will fit into the two notches on top of the lower rear panel. Secure the upper rear panel using the included panel clips (Figure 54).
4. While supporting the rear panels, insert the top edge of the one of the side panels into the upper corner of the firebox (Figure 54). Maneuver the lower edge of the panel into one of the panel holders located on each of the side walls. Repeat this step for the other side panel. Secure the side panels using the included panel clips (Figure 55).
5. Support the two side panels if necessary while inserting the cross brace to the upper front of the firebox (Figure 56). Secure the cross brace with the two combination 1/4" / Phillips bolts located at the top of the firebox ceiling. This brace will also support the glass baffle.



Figure 51: Center tab location.

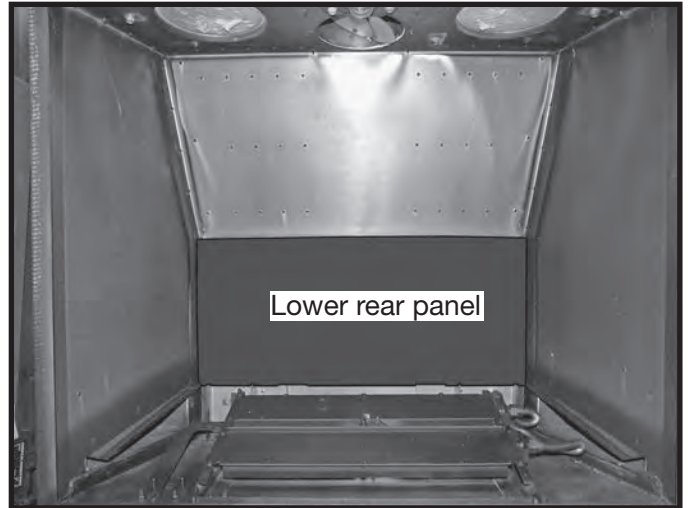

Figure 52: Lower rear panel in place.

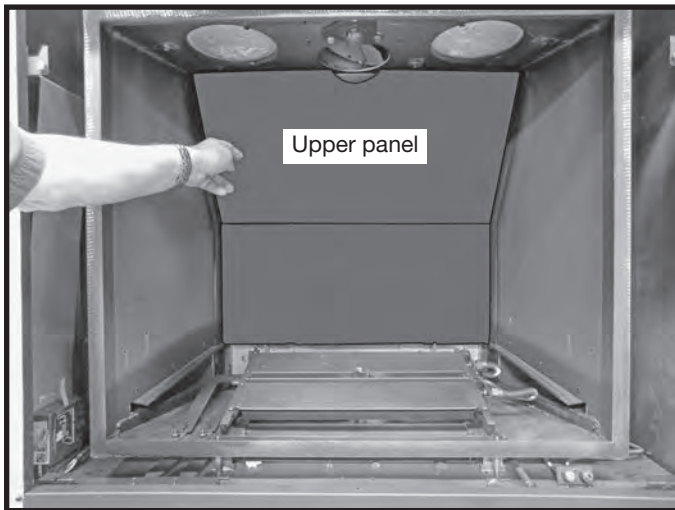

Figure 53: Upper panel in place.

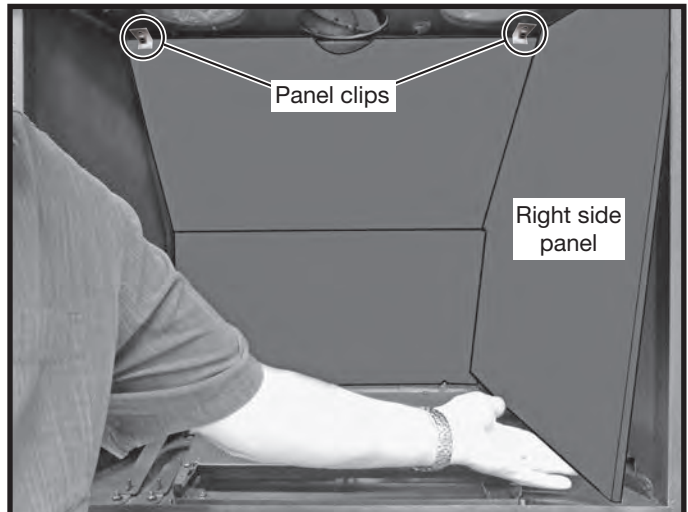

Figure 54: Right side panel in place.

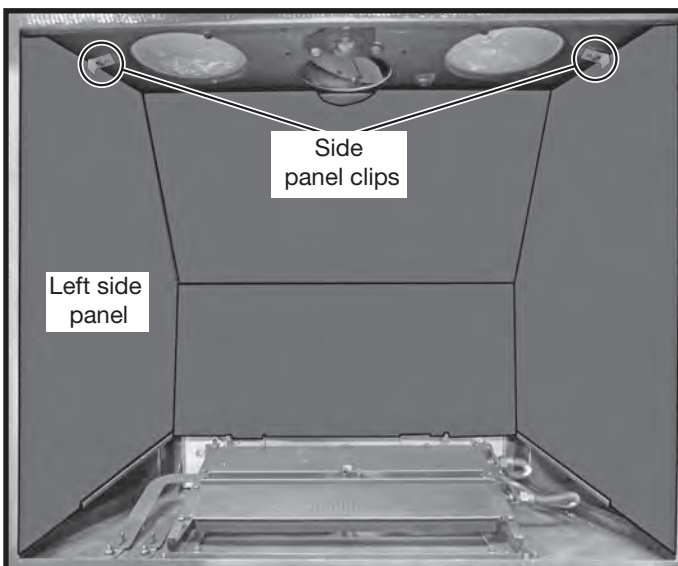

Figure 55: Left side panel in place.



Figure 56: Cross brace in place.

Glass Baffle Installation

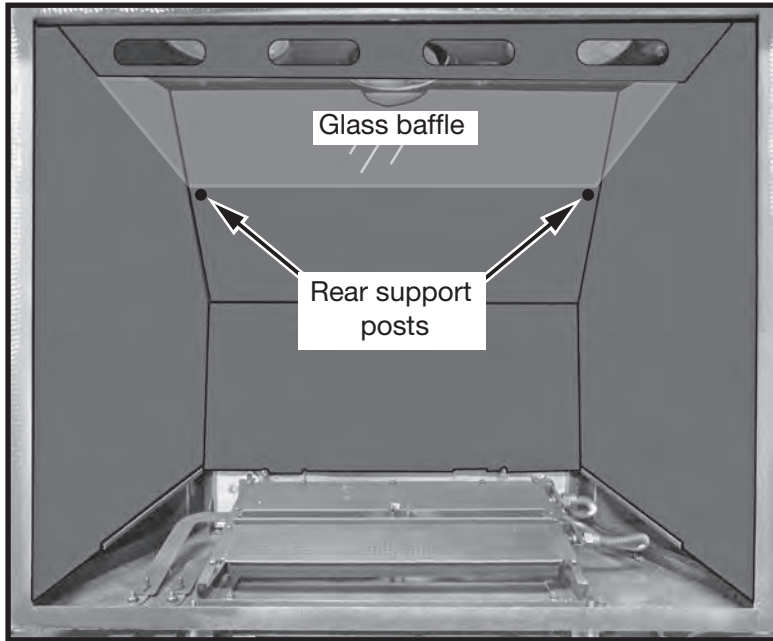

Figure 57: Glass baffle installation.

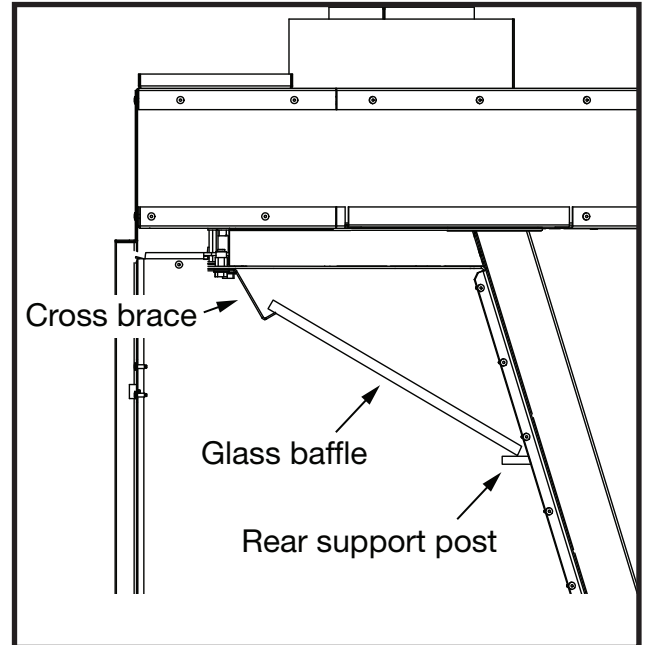

Figure 58: Glass baffle installation side view.

1. With the interior panels and the cross brace installed, insert the wide end of the glass baffle up in behind the cross brace far enough that the narrow end can be seated on top of the rear support posts (Figure 57 and Figure 58). Lower the wide end at the top and let it rest on the cross brace (Figure 58).

Log Set Installation



Figure 59: Log number 1.



Figure 60: Log number 2.



Figure 61: Log number 3.



Figure 62: Log number 4.



Figure 63: Log number 5.



Figure 64: Log number 6.



Figure 65: Log number 7.



Figure 66: Ember pieces.



Figure 67: Large ember chunks.



Figure 68: Glowing embers.

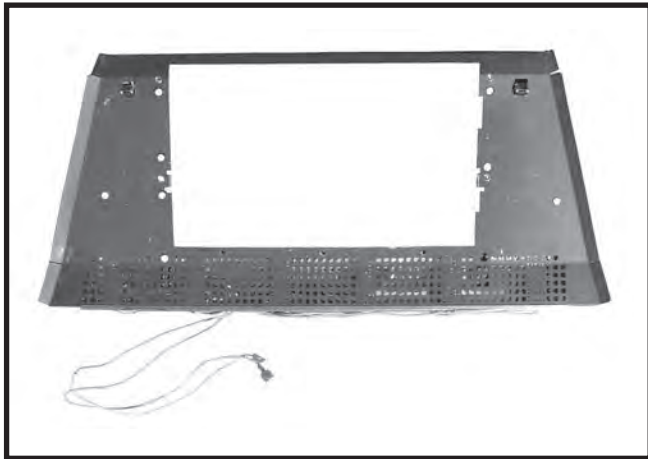

Figure 69: Lights equipped burner tray.

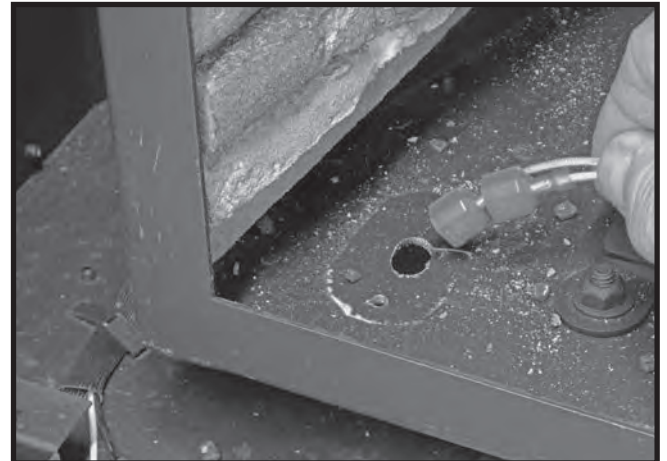

Figure 70: Feeding wires through burner plate.

1. With the fiber or porcelain interior panels installed, orient the burner tray so that its wire leads are facing the front of the fireplace (Figure 69).
2. Before placing the burner tray in its final location, feed the two leads from the burner tray in through the hole at the lower left corner of the firebox floor (Figure 70).
3. Connect the leads from the burner tray to the connectors located on the firebox floor (Figure 71).
4. Once leads are connected, place the small cover and gasket over the hole on the firebox floor and affix with two screws (Figure 71).
5. Position the burner tray over the front and rear burners and secure to the burners assembly (Figure 72).

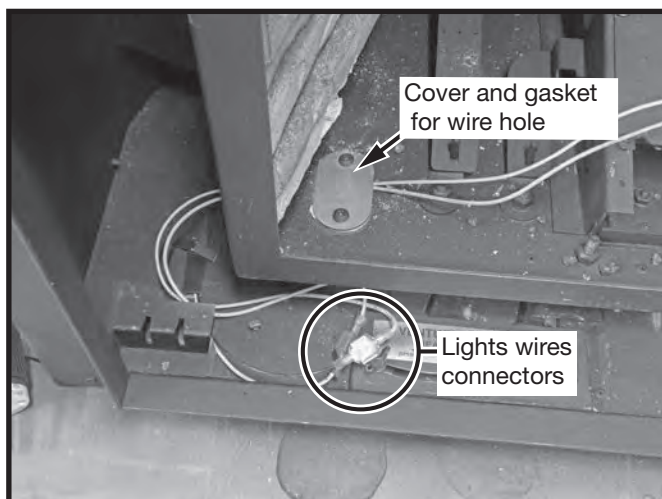

Figure 71: Lights connectors and hole cover.

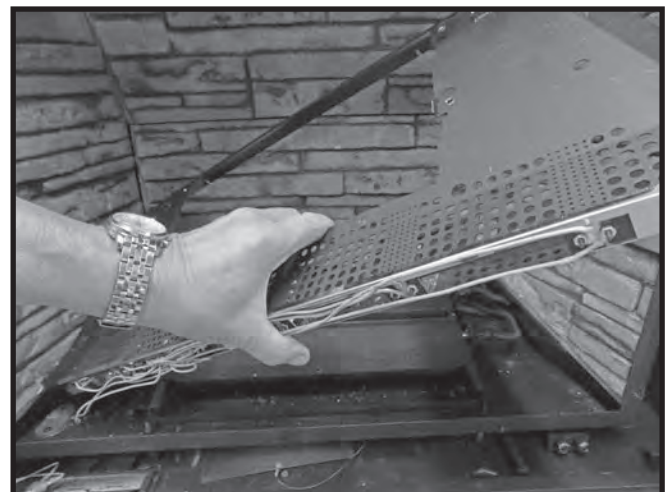

Figure 72: Putting burner tray in place.



Figure 73: Covering wires with front trim piece.



Figure 74: Amber glass pieces covering burner tray lights.

6. Place the front trim piece over the burner tray light wires to shield from view (Figure 73).
7. Fill the front of the burner tray between the front burner and the front trim piece with large amber glass pieces (Figure 74). This layer of amber glass pieces should be distributed between the right and left panels.
8. Spread a layer of small ember pieces over top of the front and rear burners (Figure 75).
9. Fill the remaining area to the left and right of the burners with large ember chunks as shown in Figure 76.



Figure 75: Small ember pieces on front and rear burners.



Figure 76: Large ember chunks on both sides of the burners.

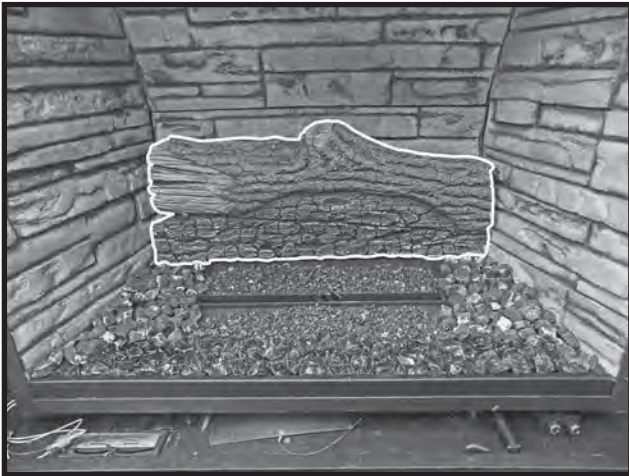

Figure 77: First log in place.



Figure 78: Large ember chunks on rear burner.

10. Position the First log at the back of the firebox so that it rests against the rear panel (Figure 77).
11. Once the First log is in place, spread some large ember chunks on the rear burner directly in front of the First log as shown in Figure 78.

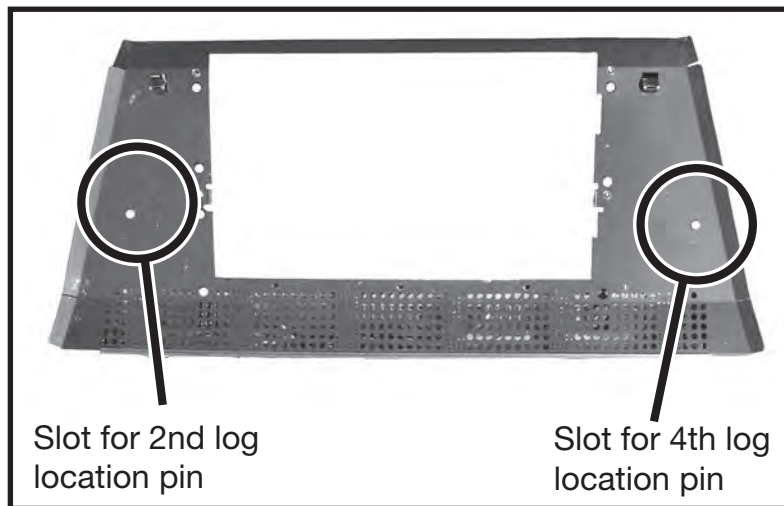

Figure 79: Slots for 2nd and 4th log location pins.



Figure 80: 2nd log in place.



Figure 81: 3rd log in place.



Figure 82: 4th log in place.



Figure 83: 5th log in place.

12. Insert the location pin for the 2nd log (See “Log number 2.” on page 35) into the left hand slot of the burner tray as shown in Figure 79.. With the post in its hole, rotate the front of the 2nd log so that its tip extends out into the middle of the front burner as shown in Figure 80.
13. Position the 3rd log (Figure 61 on page 35) so that the end with the 2 branches rests on the 2nd log as shown in Figure 81. The other end of the log must be pointed toward the front left corner of the firebox
14. The 4th log (Figure 62 on page 35) has posts on both it’s top and bottom side. Place the bottom post into the hole located on the right side of the burner tray (Figure 79). Rotate the smaller end of the log out into the center of the front burner tray as shown in Figure 82.
15. The 5th log (Figure 63 on page 35) has a slot on its bottom side which will fit over top of the post on log number 4. Place this log as shown in Figure 83.
16. The 6th log (Figure 64 on page 35) has its longer branch cradled in the notch of the 5th log. Its other end is directed toward the front right corner of the firebox (Figure 84).
17. The 7th and final log (Figure 65 on page 35) is placed mostly on the front burner with one end extending over the gap between the front and rear burner. This log is meant to obscure the pilot assembly (Figure 85).



Figure 84: 6th log in place.

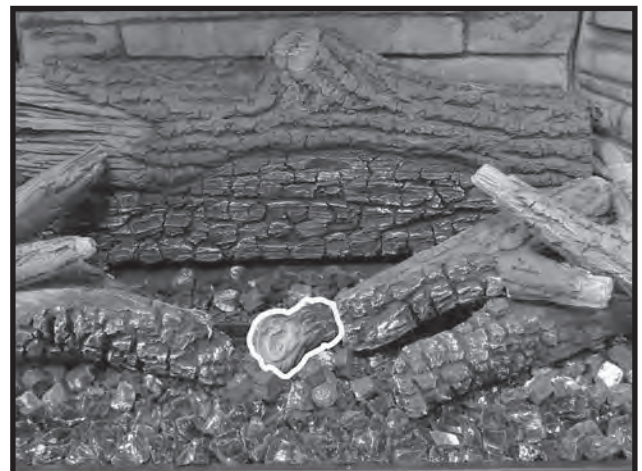

Figure 85: 7th log in place.



Figure 86: Placement of extra large ember chunks.



Figure 87: Glowing embers placement.

18. Place a few more of the large ember chunks in front of the 2nd and 4th logs as shown in (Figure 86).
19. Finally, place some of the glowing embers (Figure 68) around the areas in and around the log pieces (Figure 87).

Glass Media Installation

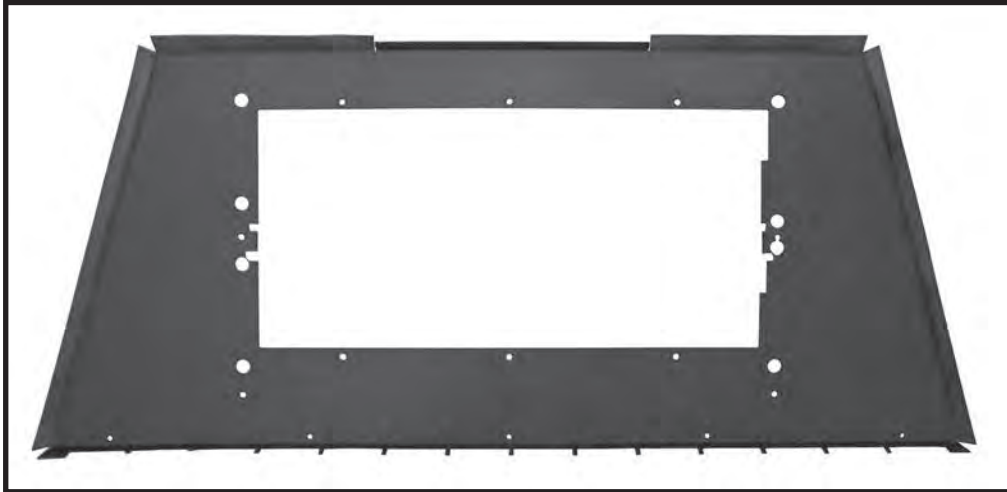

Figure 88: Glass media tray.



Figure 89: Inserting front trim piece.

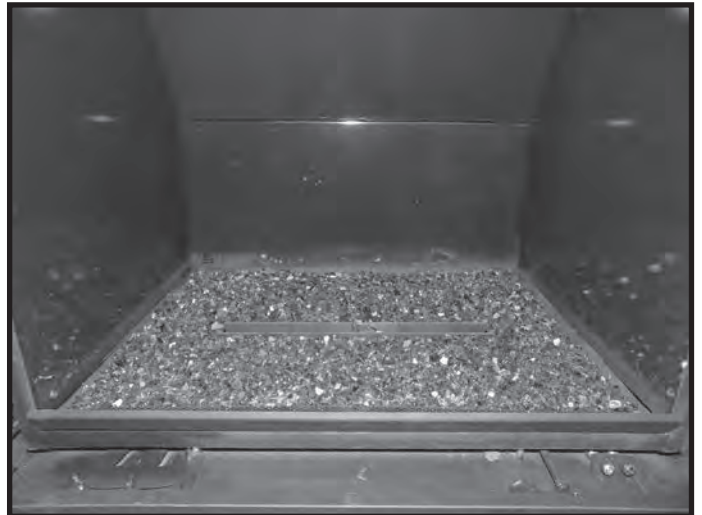

Figure 90: Crushed glass media in burner tray.

1. If choosing the crushed glass media for the fireplace display, install the burner tray (Figure 88) that comes with the crushed glass burner kit.
2. Once the burner tray is installed, insert the front trim piece as shown in Figure 89.
3. Spread crushed glass media over the entire burner tray surface. Limit the amount of crushed glass placed over the holes in the burners to a single layer of crushed glass. Too much crushed glass covering these holes can cause sooting and an undesirable flame pattern.

Door Installation/Removal

Removal

1. Remove the front screen from the front of the fireplace. See “Front Surround Installation/Removal” on page 43.
2. There are two handles located on the fireplace door (Figure 91) which must be pulled inward toward the center of the fireplace to unlock the door (Figure 92). This may take some effort because the door completes a tight seal around the firebox.
3. Remove the door and set aside.

Installation

1. Place the door over the opening of the fireplace.
2. There are two hooks on the top of the handles and two hooks on the bottom of the handle and so the door must be placed squarely over the firebox opening for all the hooks to align with the firebox.
3. Once the glass door is seated, close the door handles outward and push them until they come to a stop against the glass.
4. **The handles will close fully against the surface of the glass door (Figure 94)**
5. Return the front screen to its original position.



Figure 91: Glass door and securing hooks.

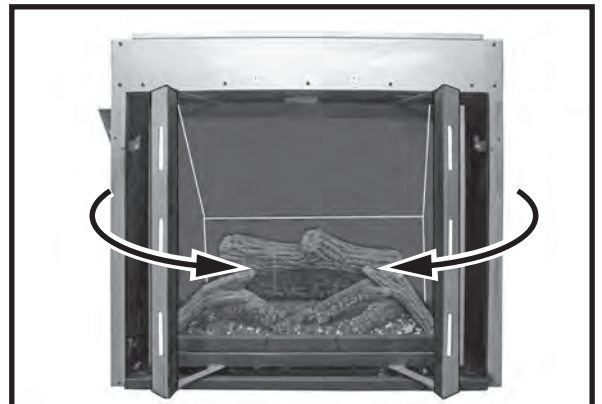

Figure 92: Unlocking the glass door.



Figure 93: Locking the glass door.

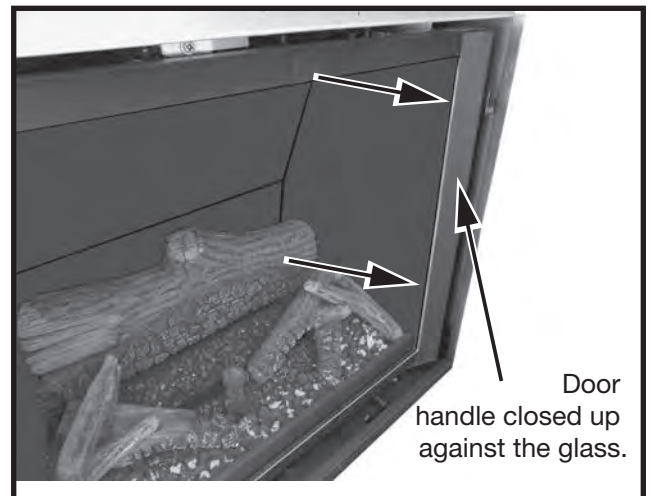

Figure 94: Glass door fully closed.

Front Surround Installation/Removal



Figure 95: Safety screen.

1. Mount the front surround by locating the lower hooks on the screen (Figure 95).
2. Place these hooks into the outside slots located on the floor of the fireplace on either side of the firebox (Figure 96).
3. Push the top of the screen toward the fireplace so that the upper hangers on the safety screen fit over top of the upper mounting hooks (Figure 97).

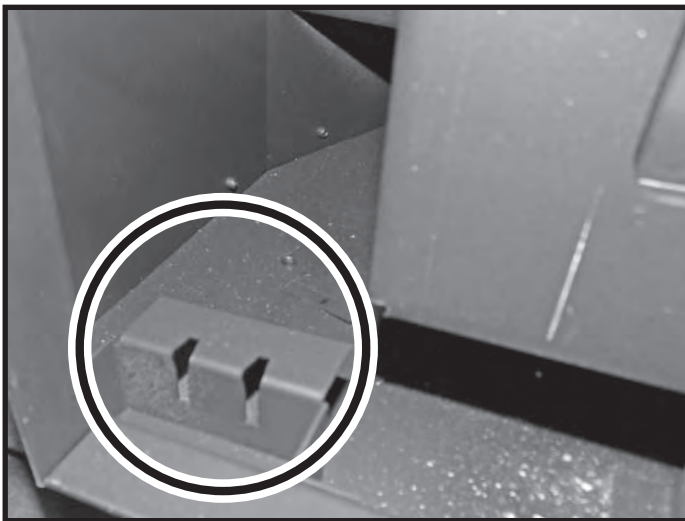

Figure 96: Lower mounting slot for safety screen.



Figure 97: Upper hook for safety screen.

Venturi Adjustment

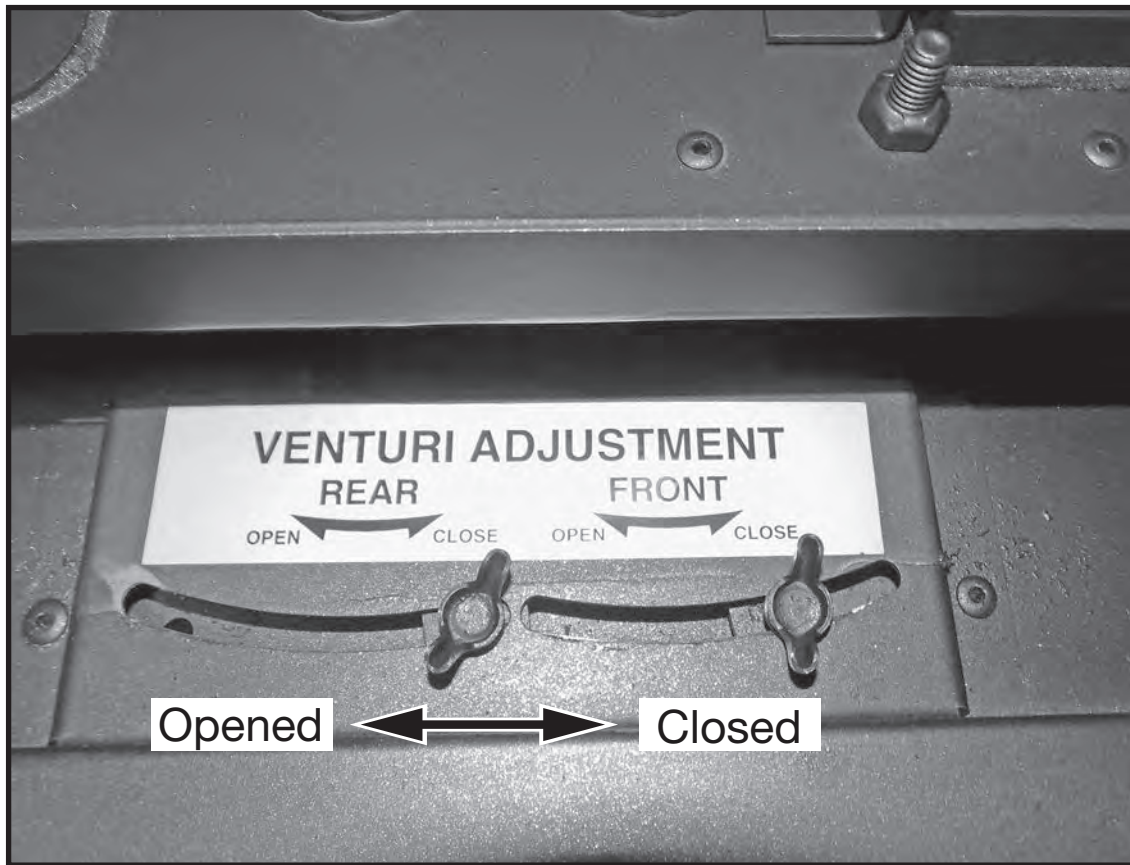

Figure 98: Venturi adjustments.

The z35 fireplace has two burners and therefore, two venturis. The venturis are easily accessible and adjustable without having to remove the glass door.

To adjust the venturis:

1. With the fireplace turned off, check that the front surround is cool to the touch.
2. Remove the front surround from the fireplace.
3. With the fireplace turned on, use the adjustments (Figure 98) to adjust for flame appearance.

Note:

The venturi settings on the z35 fireplace come preset from the manufacturer. Units that use natural gas come with the venturi adjustment set at the fully closed position while units that are configured for propane gas have their venturi adjustment set at the fully open position. It may be necessary for the installer to make a minor adjustment, whether using a natural gas model or a propane gas model, to achieve the desired flame pattern and/or to eliminate sooting.

Damper Adjustment

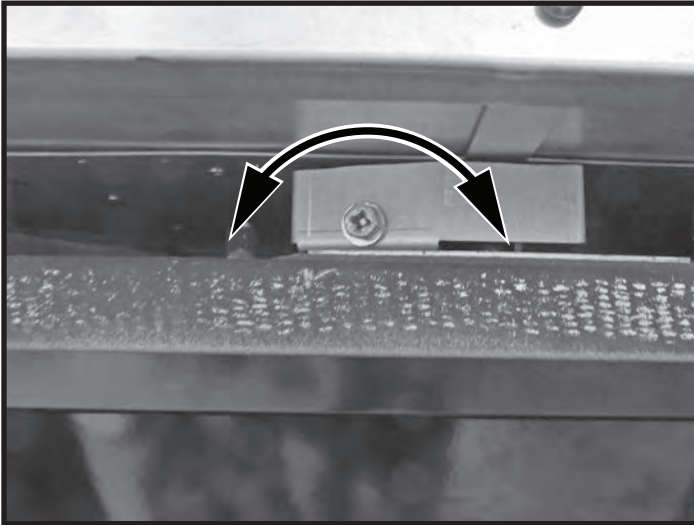

Figure 99: Damper adjustment.



Figure 100: Damper port (center).

Note: Be aware that the damper adjustment mechanism may be hot if the fireplace has been burning for any length of time.

The z35 fireplace comes with an adjustable damper. This damper adjustment is located behind the safety screen just above the glass door (Figure 99). Sometimes on installations that involve vertical venting configurations over 10 feet in height, the intake air tends to accelerate down the vent causing hectic flame action. This damper can be closed partially to reduce the speed of the intake air and thus calm the flames to a more natural look. Over-closure of this damper could cause an insufficient air supply to the fire, which would result in flames that cause soot.

Damper Adjustment:

To adjust the damper, remove the front surround and locate the bolt (3/8" or Phillips) above the glass door (Figure 99). Visually adjust the damper as follows:

- To position the damper (for a 35' flue), turn the adjustment bolt so that the damper is about 20% open.
- To position the damper (for a 10' flue), turn the adjustment bolt so that the damper is about 80% open.

Control Panel Removal / Installation

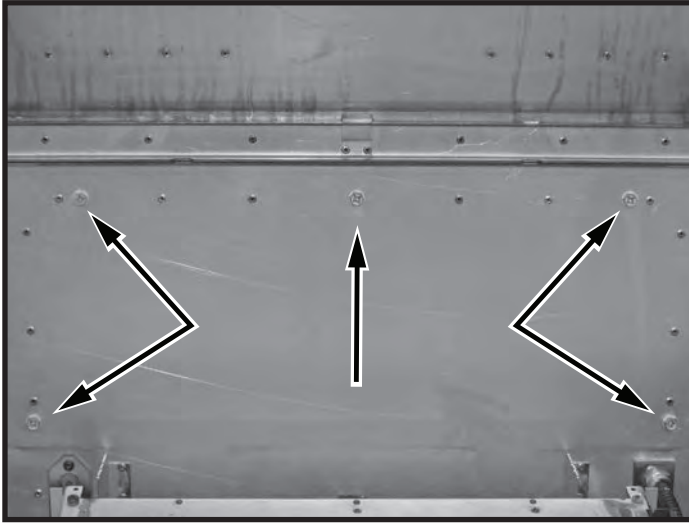

Figure 101: Control panel access bolts.

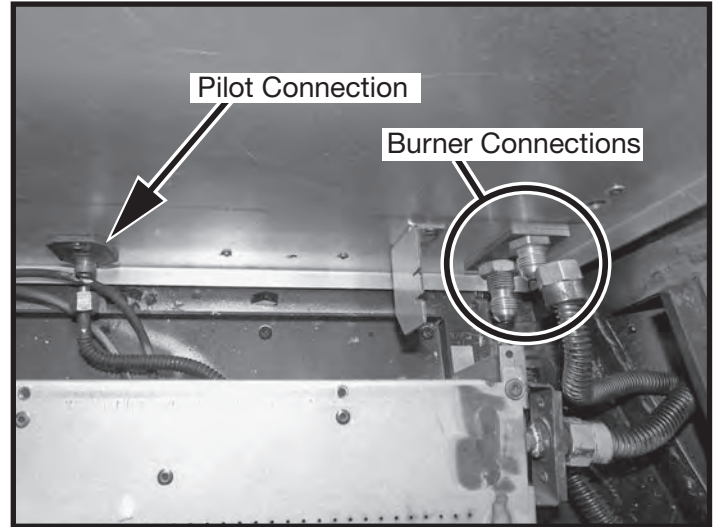

Figure 102: Gas connections in the firebox.

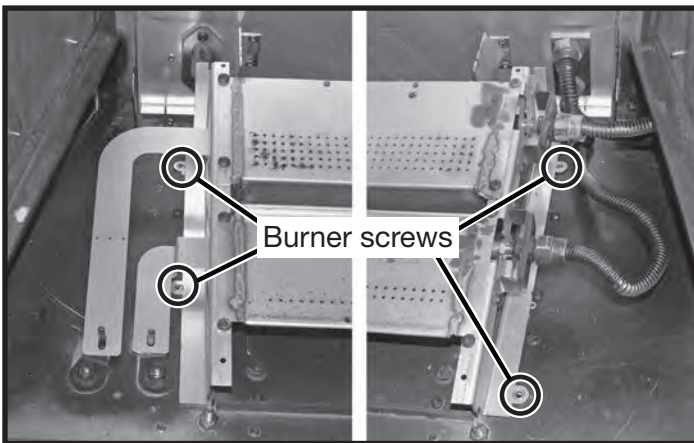

Figure 103: Burner unit screws.

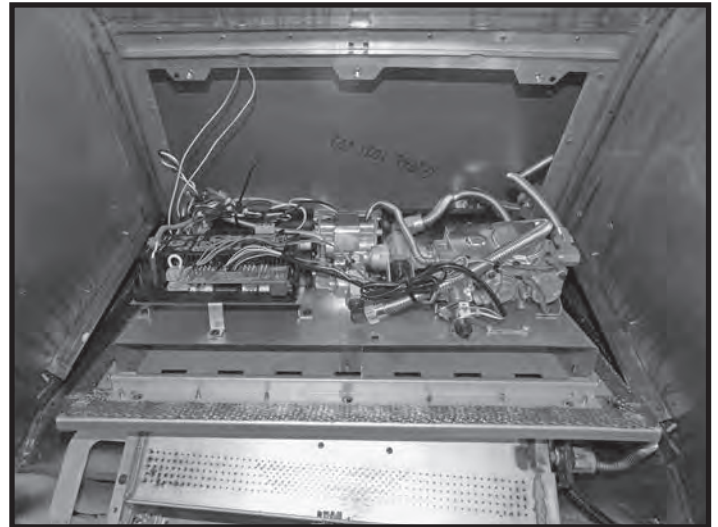

Figure 104: Slide panel toward fireplace opening.

Removal

1. Remove front surround and glass door.
2. Remove log set or glass media and vacuum up glowing embers or crushed glass.
3. Remove baffle and panels.
4. Release 3 gas connection points as shown in Figure 102.
5. Remove 5 screws holding the control panel unit to the firebox back (Figure 101).
6. Allow the loose panel to be lowered on top of the burner tray.

Installation is reverse of removal.

Maintenance

Turn off gas and electrical power supply (if applicable) and allow ample time for unit to cool before servicing appliance. It is recommended that the fireplace and its venting should be inspected at least once a year by a qualified service person.

Glass Door:

Warning: Do not operate fireplace with glass door removed, cracked or broken. Replacement of the glass door should be done by a licensed or qualified service person. Check glass panel gasket, replace if necessary. It is important that the glass seal be maintained in good condition.

Do not strike or otherwise impact the glass in any way that may cause it to break. If the glass becomes cracked or broken it must be replaced before using the fireplace. Replacement door can be obtained from your nearest Pacific Energy dealer. Do not substitute with any other type. To remove broken glass, remove Door as noted in “Door Installation/Removal” on page 42.

Annual Inspection:

- a) Remove glass door and decorative media (such as logs and rocks). Inspect decorative media and burner assemblies for soot buildup. If excessive buildup of soot is present, have a qualified service person inspect and adjust unit for proper combustion. Clean burners with a brush or vacuum cleaner, paying close attention to burner ports.
- b) Check the pilot system for proper flame size and operation. Clean pilot free (Figure 105) of soot, dust or any other deposits.
- c) Check that the vent pipe and vent terminal are open and free from blockage or debris. If the venting is disassembled for cleaning, it must be properly assembled and re-sealed. Refer to VENTING section for proper procedure.
- d) Check and replace batteries as needed.

Note: The appliance area must be kept clear and free from combustible materials, gasoline and other flammable vapors and liquids.

Periodically:

- a) Viewing glass may be cleaned as necessary with fireplace glass cleaner.
- b) Exterior finish may be cleaned with mild soap and water.

CAUTION: Do not use abrasive cleaners on glass or any other part of the fireplace.

Do not clean glass when hot.

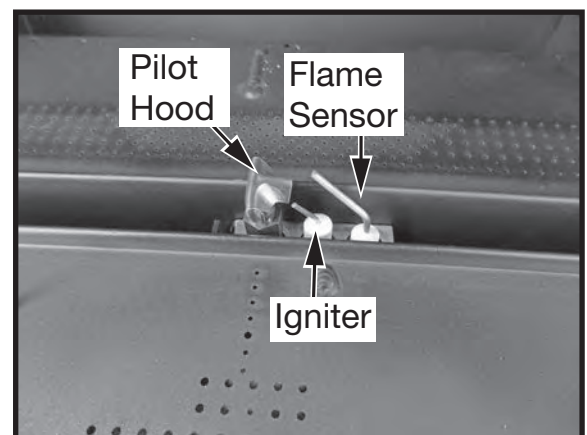

Figure 105: Pilot assembly.

Pairing the Control Module and Fireplace

Pacific Energy Fireplaces can be operated remotely by using the remote handset that came with the fireplace.

The linking procedure establishes a link between the wall switch and the fireplace, followed by a procedure to establish a link between the wall switch and the remote hand set.

Step 1: Procedure for linking / pairing wall switch to fireplace

1. Install 4 AA batteries into the battery holder located inside the wall switch (Figure 106).
(Note: Although batteries in the wall switch are not necessary for linking the wall switch to the remote handset and remotely using the handset to operate the fireplace, the batteries are needed in the wall switch in order to continue using the fireplace during a power outage).
2. Install 3 AAA batteries into the Proflame 2 Remote Handset (Figure 107).
3. Set the wall switch selector to the “Remote” setting.
4. Press and hold Program button (Figure 108) on the wall switch for up to 10 seconds. Use a straightened paper clip to access the button.
5. The wall switch will beep 3 times. Release the button following the beeps.
6. The fireplace will beep 3 times repeated by another 3 beeps.
7. The fireplace and wall switch are now linked/paired.

If there is cross communication with another nearby fireplace causing the other fireplace to activate instead of the intended fireplace, repeat above procedure to automatically switch to another one of three available channels.



Figure 106: Wall switch battery pack.



Figure 107: SIT remote handset and battery holder.

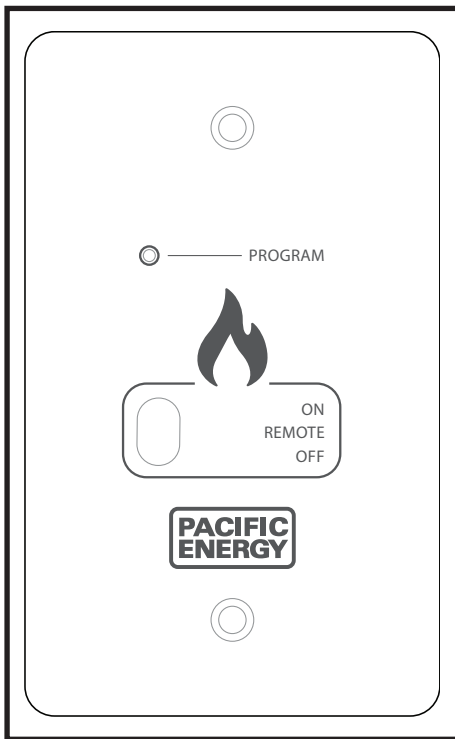

Figure 108: SIT Wall switch.



Figure 109: Remote handset.

Step 2: Procedure for linking / pairing the wall switch to remote handset

1. Press and release **Program** button on the wall switch once (Figure 108).
2. You will hear 5 beeps from the wall switch.
3. Press and release the **on/off** button (Figure 109) on the remote handset (within 60 sec).
4. The wall switch will beep 3 times.
5. The remote handset is now linked/paired to the wall switch and is ready to activate the fireplace.

Halogen Lamp Replacement

This fireplace comes with a Halogen Lamp which may need to be replaced on occasion. To access the bulb:

1. Remove the safety screen from the fireplace, see “Front Surround Installation/Removal” on page 43.
2. Remove the glass door. See “Door Installation/Removal” on page 42.
3. Remove the cross brace. See “Panel Installation” on page 32.
4. Loosen the 3 bolts (It is not necessary to remove them) holding the lamp assembly plate (Figure 110) twist the plate clockwise and remove.
5. Twist off the lamp dome (Figure 112) and remove the old lamp.
6. Wear gloves when installing a new lamp, touching the lamp with bare fingers will leave oil and residue on the lamp and can reduce the lamps’ life span.

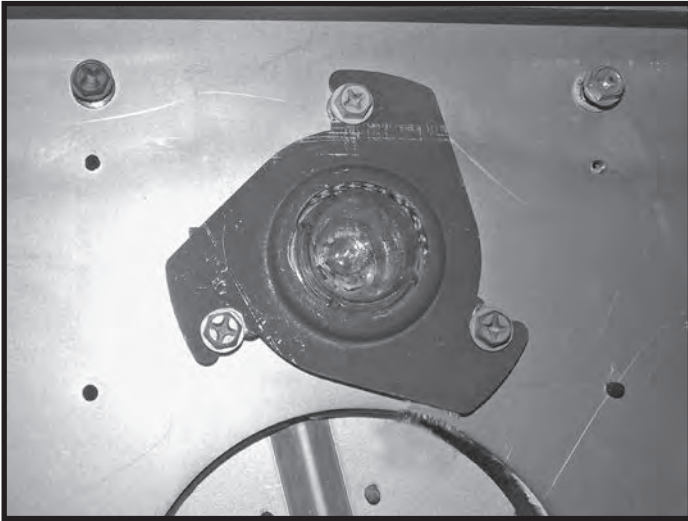

Figure 110: Light fixture.



Figure 111: Replacing bulb.



Figure 112: Glass dome.

Module & Gas Valve Details

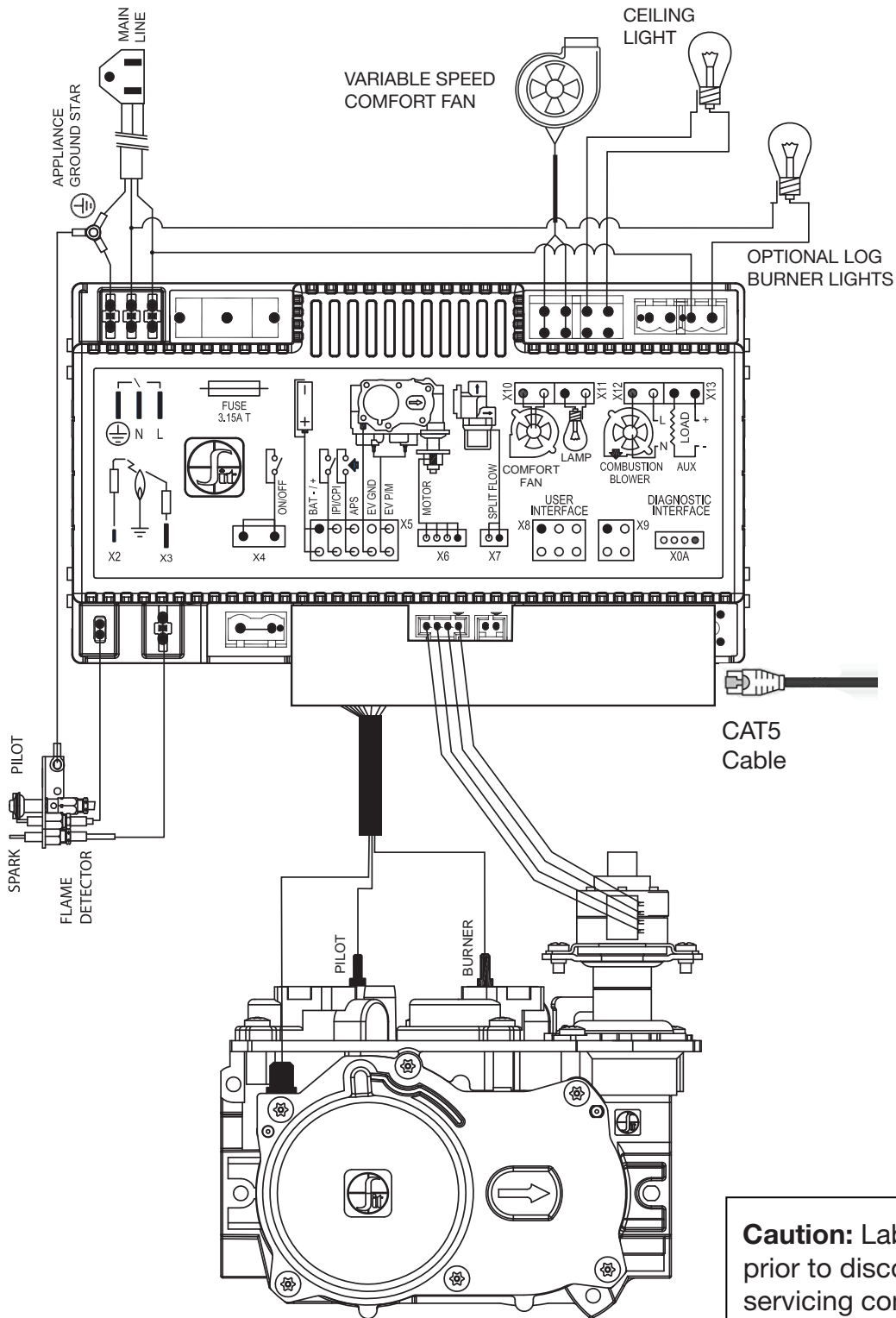

Figure 113: SIT wiring diagram.

Caution: Label all wires prior to disconnection when servicing controls. Wiring errors can cause improper and dangerous operation. Verify proper operation after servicing.

Wiring Diagram

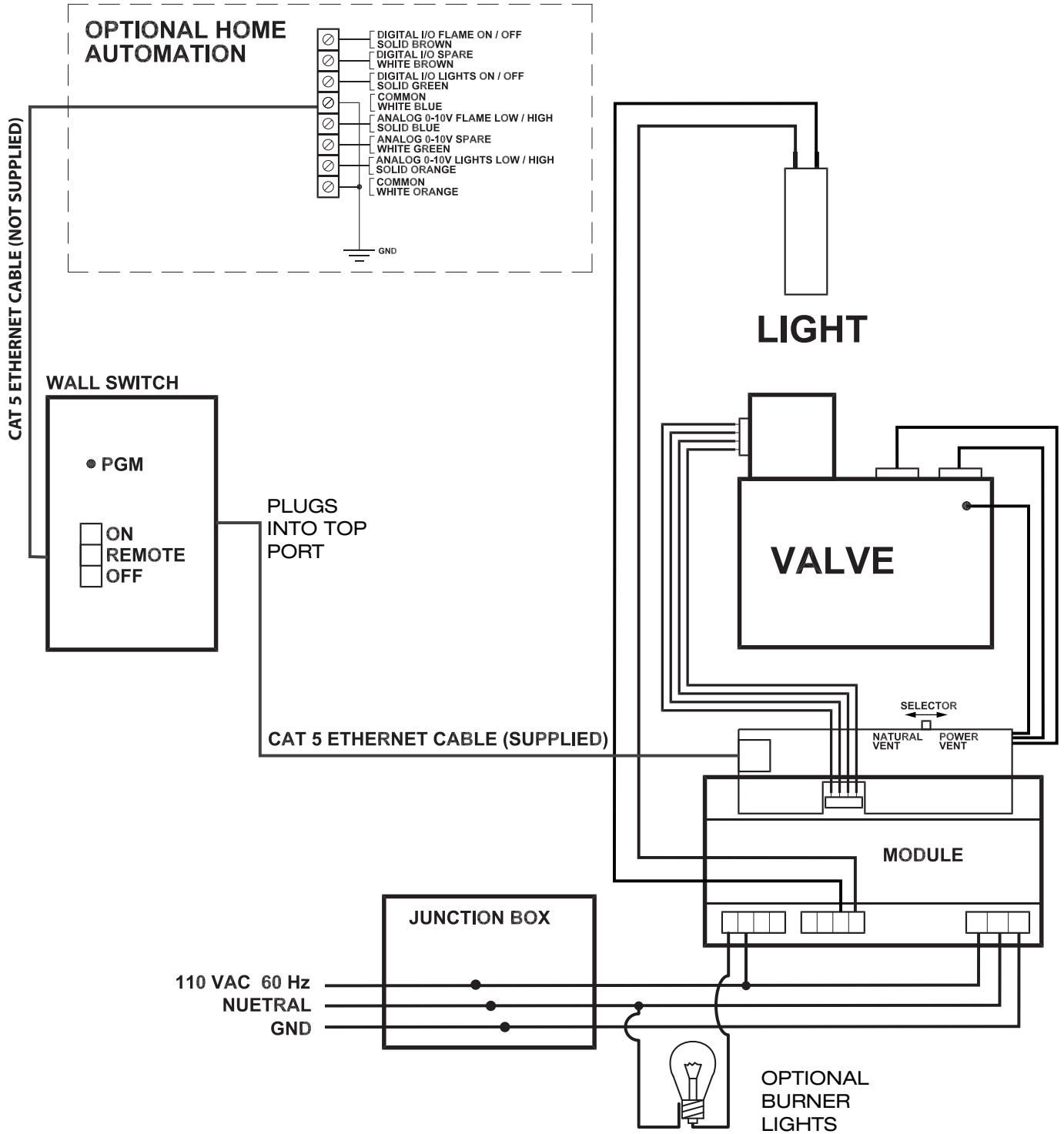
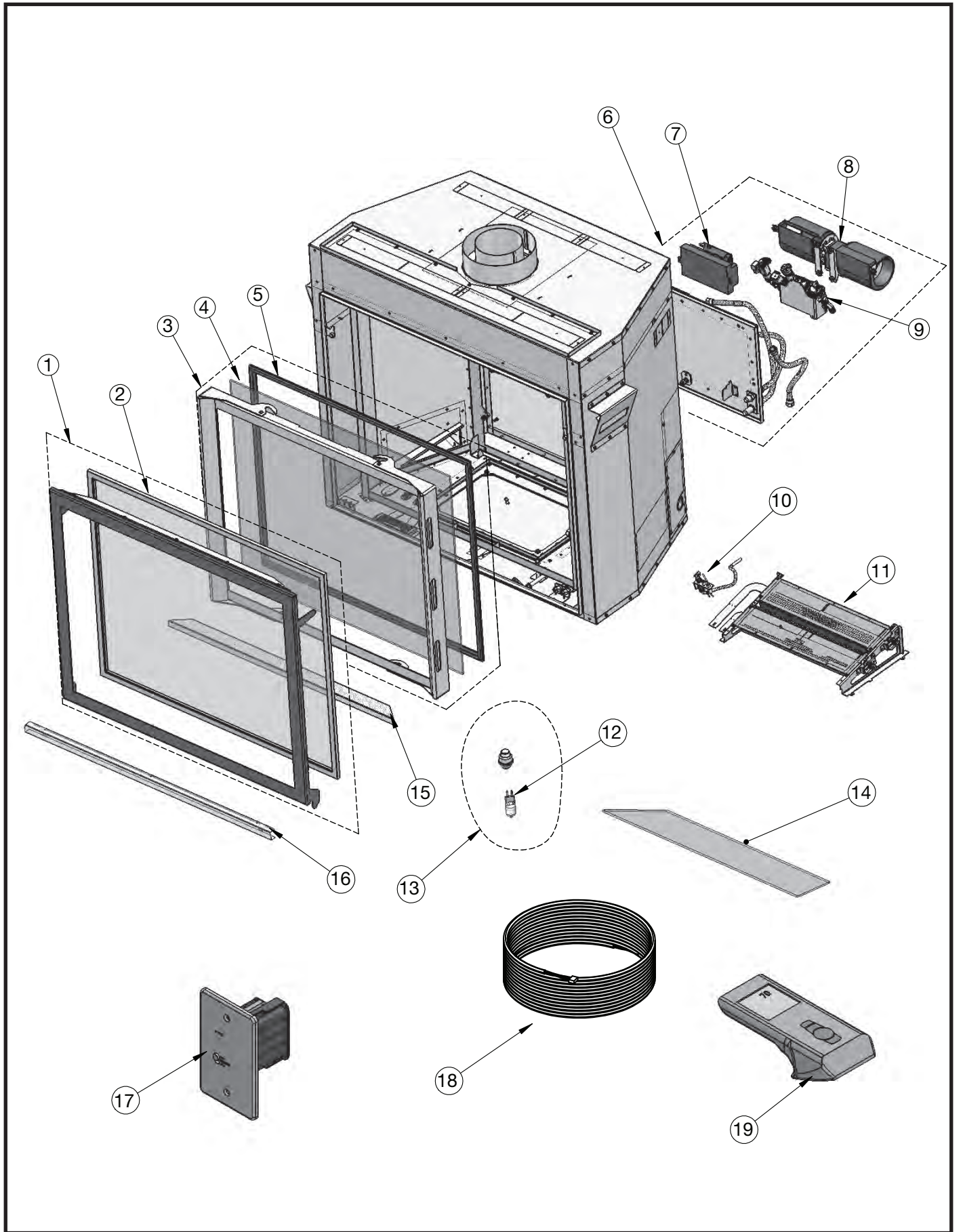

Figure 114: Wiring diagram for units.

Replacement Parts

1	Screen Front Assembly.....	80002322
2	Safety Screen.....	80002187
3	Window Frame Assembly	80002188
4	Glass, c/w Gasket.....	80002315
5	Window Gasket.....	80002319
6	Control Assembly.....	80002190
7	Module Assembly	80000518
8	Blower	80001858
9	Valve, c/w Split Flow Valve, NG	80002320
	Valve, c/w Split Flow Valve, LP	80002321
10	Pilot Assembly, SIT	80002192
11	Burner Assembly, NG	80002189
	Burner Assembly, LP	80002191
12	Light Bulb, Halogen, 25W	80001421
13	Halogen Lamp Assembly.....	80002193
14	Glass Baffle.....	80002318
15	Trim, Decorative	80002317
16	Trim, Lower Filler	80002316
17	Wall Switch	80002194
18	Cat 5 Cable.....	80001707
19	Remote, SIT	80000004



Rating Label

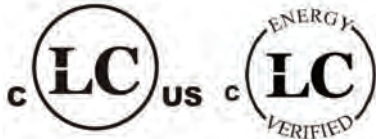

MODEL / MODELE:
z35

P.4.1 - 15 Efficiency	NG 72.1 % LP 70.9 %
--------------------------	------------------------

SERIES/
SERIE: **A**



MADE IN CANADA
FABRIQUE AU CANADA

100000967-50 z35 110419

WARNING: Improper installation, adjustment, alteration, service or maintenance can cause injury or property damage. Refer to the owner's information manual provided with this appliance. For assistance or additional information, consult a qualified installer, service agency or the gas supplier. **AVERTISSEMENT:** Une installation, un réglage, une modification, une réparation ou un entretien mal effectuée peut causer des dommages matériels ou des blessures. Voir la notice de l'utilisateur qui accompagne l'appareil. Pour de l'aide ou des renseignements supplémentaires, consultez un installateur, un technicien agréé ou le fournisseur de gaz.

Unit electrical rating: 115v, 60hz, 2A / Normes electriques du unité: 115v, 60hz, 2 A. This appliance equipped for altitudes 0 - 4500 ft. (0 - 1372 m) / Cet unité est conçu pour des altitudes variant entre 0 - 4500 pieds (0 - 1372 m). In Canada, also certified for installation in a bedroom or a bedsitting room / Aussi certifié pour installation dans une chambre à coucher ou une salle de séjour. This appliance must be installed in accordance with local codes, if any; if none, follow the current CAN/CGA-B149 (Canada), or ANSI Z223.1 (USA) Installation Codes. Installer l'appareil selon les codes ou règlements locaux, ou, en l'absence de tels règlements, selon les codes d'installation CAN/CGA-B149 (Canada), or ANSI Z223.1 (USA) en vigueur.

**Clearance to combustibles
Dégagements aux combustibles**

Bottom of appliance to 6" mantel: Fond de l'appareil à la cheminée de 14 po:	42" 35 po
Center of appliance to side wall: Centre de l'appareil sur le mur latéral:	20" 20 po
Hearth in front of appliance: Foyer devant l'appareil:	0" 0 po
Under appliance: Sous l'appareil:	0" 0 po
Objects in front of appliance: Objets devant l'appareil:	36" 36 po

**VENTED GAS FIREPLACE - NOT FOR USE WITH
SOLID FUEL. FOYER AU GAZ À ÉVACUATION -
NE PAS UTILISER AVEC DU COMBUSTIBLE
SOLIDE**

ANSI Z21.88-2017 / CSA 2.33-2017 Vented Gas
Fireplaces/Heaters.
CAN/CGA 2.17-2017 Gas-Fired Appliance For Use At
High Altitudes.
Certified for / Certifié pour Canada and U.S.A.



This Appliance is Equipped For Use With /
Cet Appareil est Équipé Pour Utiliser Avec :
NATURAL GAS / LP-GAS
DU GAZ NATUREL / LP GAZ

FOR USE WITH/ EN CASE D'EMPLOI AVEC:	NATURAL GAS DU GAZ NATUREL	LP GAS/ DU GAZ LP
Minimum supply pressure / Pression minimum d'alimentation: (For the purpose of input adjustment / dans le but de régler l'alimentation)	5.0 in/wc / 5.0 po/c.e. (1.25 kPa)	12.5 in/wc / 12.5 po/c.e. (3.11 kPa)
Maximum supply pressure / Pression maximum d'alimentation:	13.9 in/wc / 13.9 po/c.e. (3.45 kPa)	13.9 in/wc / 13.9 po/c.e. (3.45 kPa)
Manifold pressure / Pression de la tuyauterie: Maximum	3.5 in/wc / 3.5 po/c.e. (0.87 kPa)	10 in/wc / 10 po/c.e. (2.48 kPa)
Orifice Size / Diametre de l'injecteur:	Front: EF, Rear: EG	Front: EJ, Rear: EK
Input BTU/hr (kW) / Entree BTU/h (kW):	Max. 35,000 (10.3) Min. 9,000 (2.63)	Max. 26,000 (7.61) Min. 7,500 (2.19)

Date of Manufacture:

MANUFACTURED (MOBILE) HOME: This appliance is only for use with the type of gas indicated on the rating plate and may be installed in an aftermarket, permanently located, manufactured (mobile) home where not prohibited by local codes. See owners manual for details. **FABRIQUEZ (MOBILE) MAISON:** Cet appareil doit être utilisé uniquement avec le type de gaz indiqué sur la plaque signalétique et peut être installé dans une maison préfabriquée (mobile) installée à demeure si les règlements locaux le permettent. Voir la notice du propriétaire pour plus de détails. Cet appareil ne peut être converti à d'autres gaz sauf si une trousse de conversion certifiée est utilisée. Install in accordance with the current standard Mobile Homes, CAN/CSA Z240 MH (in CANADA), and the Manufacturer's Home Construction and Safety Standard, Title 24 CFR, Part 3280, or the current Standard for Fire Safety Criteria for Manufactured Home Installations, Sites, and Communities ANSI/NFPA 501A, (in the U.S.A.). Cet appareil doit être installé conformément aux exigences de la norme CAN/CSA Z240 MH en vigueur de l'ACNOR, Installations de gaz dans les Constructions Mobiles. **FOR USE WITH THE GLASS AND SCREEN BARRIER CERTIFIED WITH THE APPLIANCE ONLY / POUR UTILISATION UNIQUEMENT AVEC LES PORTES IN VERRE CERTIFIÉES AVEC L'APPAREIL.**



© 2019 Copyright Pacific Energy Fireplace Products LTD

Reproduction, adaptation, or translation without prior written permission is prohibited, except as allowed under the copyright laws.



For technical support, please contact your retailer

**Web site: www.pacificenergy.net
2975 Allenby Rd., Duncan,
BC V9I 6V8**

Printed in Canada