



WARRANTY REGISTRATION  
[enviro.com/warranty](http://enviro.com/warranty)

# Berkeley-IPI / Berkeley-D

FREESTANDING GAS FIREPLACE

# OWNER'S MANUAL



**WARNING:** If the information in this manual is not followed exactly, a fire or explosion may result causing property damage, personal injury or loss of life. Installation and service must be performed by a qualified installer, service agency or the gas supplier.

# SAFETY PRECAUTIONS

---



## **WARNING:**

### **FIRE OR EXPLOSION HAZARD**

**Failure to follow safety warnings exactly could result in serious injury, death, or property damage.**

- Do not store or use gasoline or other flammable vapors and liquids in the vicinity of this or any other appliance.
  
- **WHAT TO DO IF YOU SMELL GAS**
  - Do not try to light any appliance.
  - Do not touch any electrical switch; do not use any phone in your building.
  - Leave the building immediately.
  - Immediately call your gas supplier from a neighbor's phone. Follow the gas supplier's instructions.
  - If you cannot reach your gas supplier, call the fire department.
  
- Installation and service must be performed by a qualified installer, service agency or the gas supplier.

### **INSTALLER:**

Leave this manual with the appliance.

### **CONSUMER:**

Retain this manual for future reference.

This appliance may be installed in an after-market permanently located, manufactured (mobile) home, where not prohibited by local codes.

This appliance is only for use with the type of gas indicated on the rating plate. This appliance is not convertible for use with other gases, unless a certified kit is used.

Only doors certified with the appliance shall be used

Massachusetts installations (Warning): This product must be installed by a licensed plumber or gas fitter when installed within the Commonwealth of Massachusetts. Other Massachusetts code requirements: Flexible connector must not be longer than 36in., a shut off valve must be installed; only direct vent sealed combustion products are approved for bedrooms/bathrooms. A carbon monoxide detector is required in all rooms containing gas fired direct vent appliances. The fireplace damper must be removed or welded in the open position prior to installation of a fireplace insert.

# SAFETY PRECAUTIONS

FOR SAFE INSTALLATION AND OPERATION OF YOUR "ENVIRO" HEATER, PLEASE CAREFULLY READ THE FOLLOWING INFORMATION:

- All ENVIRO gas-fired appliances must be installed in accordance with their instructions. Carefully read all the instructions in this manual first. Consult the building authority having jurisdiction to determine the need for a permit prior to commencing the installation.
- **NOTE:** Failure to follow these instructions could cause a malfunction of the fireplace, which could result in death, serious bodily injury, and/or property damage.
- Failure to follow these instructions may also void your fire insurance and/or warranty.

## GENERAL

• Installation and repair should be done by a qualified service person. The appliance should be inspected before the first use and, at least, annually by a qualified service person. More frequent cleaning may be required due to excessive lint from carpeting, bedding material, etc. It is imperative the control compartments, burners and circulating air passageways of the appliance be kept clean.

• Due to high temperatures, the appliance should be located out of high traffic areas and away from furniture and draperies.

**Children and adults should be alerted to the hazards of high surface temperatures and should stay away to avoid burn or clothing ignition.**

• Young children should be carefully supervised when in the same room as the appliance. Toddlers, young children and others may be susceptible to accidental contact burns. A physical barrier is required if there are at risk individuals in the house. To restrict access to a fireplace or stove install an adjustable safety gate to keep toddlers, young children and other at risk individuals out of the room and away from hot surfaces. Any safety screen, guard, or barrier removed for servicing an appliance must be replaced prior to operating the appliance.

• Clothing or other flammable materials should not be placed on or near the appliance.

• A barrier designed to reduce the risk of burns from the hot viewing glass is provided with this appliance and shall be installed for the protection of children and other at-risk individuals. If the barrier becomes damaged, the barrier shall be replaced with the manufacturer's barrier for this appliance

## FOR YOUR SAFETY

- Installation and service must be performed by a qualified installer, service agency or gas supplier.
- This installation must conform to local codes or, in the absence of local codes, with the National Fuel Gas Code, ANSI Z223.1/NFPA 54, or the Natural Gas and Propane Installation Code, CSA B149.1.
- To prevent injury, do not allow anyone who is unfamiliar with the stove to operate it.

**• To prevent injury, if the pilot or pilot and burners have gone out on their own, open the glass door and wait 5 minutes to air out before attempting to re-light the stove.**

• Always keep the area around these appliances clear of combustible material, gasoline and other flammable liquids and vapours.

• These appliances should not be used as a drying rack for clothing or for hanging Christmas stockings/decorations.

• Due to the paint curing on the stove, a faint odor and slight smoking will likely be noticed when the stove is first used. Open a window until the smoking stops.

Always connect this gas stove to a vent system and vent to the outside of the building envelope. Never vent to another room or inside the building. Make sure the specified vent pipe is used, properly sized and of adequate height to provide sufficient draft. Inspect the venting system annually for blockage and signs of deterioration.

**WARNING:** Failure to position the parts in accordance with the diagrams in this booklet, or failure to use only parts specifically approved with this appliance, may result in property damage or personal injury.

**WARNING:** Do not operate with the glass front removed, cracked or broken. Replacement of the glass should be done by a licensed or qualified service person.

• Never use solid fuels such as wood, paper, cardboard, coal, or any flammable liquids, etc., in this appliance.

• Do not use this appliance if any part has been under water. Immediately call a qualified service technician to inspect the appliance and to replace any part of the control system or any gas control which has been under water.

• Do not abuse the glass by striking it or slamming the door shut.

• If the Berkeley unit is pulled out of its installation, and the vent-air intake system is disconnected for any reason, ensure that the vent-air intake pipes are reconnected and re-sealed in accordance to the instructions noted in INITIAL INSTALLATION - DIRECT VENT



# DANGER



**HOT GLASS WILL CAUSE BURNS**

**DO NOT TOUCH GLASS UNTIL COOLED.**

**NEVER ALLOW CHILDREN TO TOUCH GLASS.**

A barrier designed to reduce the risk of burns from the hot viewing glass is provided with this appliance and shall be installed for the protection of children and other at-risk individuals.

# TABLE OF CONTENTS

---

Safety Precautions.....	2
Table of Contents.....	4
Codes And Approvals.....	5
Specifications.....	6
Dimensions.....	6
Rating Label Location.....	6
Operating Instructions.....	7
Lighting Instructions.....	7
Air Shutter.....	8
Normal Sounds During Operation.....	8
Transmitter.....	9
Initializing the System for the First Time.....	11
Switching to Continuous Pilot.....	11
Turn off the Appliance.....	12
Room Thermostat.....	12
Remote Flame Control.....	12
Split Flow Operation.....	13
Fan Control.....	13
Key Lock.....	14
Low Battery Power Detection.....	14
Maintenance and Service.....	14
Routine Maintenance.....	14
Cleaning Decorative Surfaces.....	14
Cleaning the Glass.....	15
Cleaning the Firebox.....	15
Replacing the Glass.....	15
Flashout Guard.....	15
Cast Door Removal.....	16
Glass Door Removal.....	16
Burner Removal.....	17
Fuel Conversion.....	18
Initial Installation.....	20
Preparation for Installation.....	20
Clearance to Combustibles.....	20
Direct Vent.....	21
Venting Clearances.....	21
Approved Venting Parts.....	22
Horizontal Termination - Minimum Vent.....	23
Vent Termination Restrictions.....	24
Allowable Vent Configurations.....	25
Air Restrictor Settings.....	26
Horizontal Termination.....	27
Vertical Termination.....	28
Gas Line Connection and Testing.....	31
Electrical Requirements.....	32
Secondary Installation.....	33
Log Set Installation.....	33
Safety Screen Replacement.....	36
Trouble Shooting.....	37
Parts List.....	40
Warranty.....	43
Installation Data Sheet.....	44

# CODES AND APPROVALS

**DIRECT VENT ONLY:** This type is identified by the suffix DV. This appliance draws all of its air for combustion from outside the dwelling, through a specially designed vent pipe system.

This appliance has been tested and approved for installations from 0 feet to 4500 feet (1372 m) above sea level.

**In the USA:** The appliance may be installed at higher altitudes. Please refer to your American Gas Association guidelines which state: the sea level rated input of Gas Designed Appliances installed at elevations above 2000 (610 m) feet is to be reduced 4% for each 1000 feet (305 m) above sea level. Refer also to local authorities or codes which have jurisdiction in your area regarding the de-rate guidelines.

**In Canada:** When the appliance is installed at elevations above 4500 feet (1372 m), the certified high altitude rating shall be reduced at the rate of 4% for each additional 1000 feet (305 m).

- This appliance has been tested by INTERTEK and found to comply with the established VENTED GAS FIREPLACE HEATER standards in CANADA and the USA as follows:

**VENTED GAS FIREPLACE HEATER (Berkeley; NG/LPG)**  
TESTED TO: ANSI Z21.88 / CSA 2.33 VENTED GAS FIREPLACE HEATERS  
CSA 2.17 GAS FIRED APPLIANCES FOR HIGH ALTITUDES  
CSA P.4.1 TESTING METHOD FOR MEASURING ANNUAL FIREPLACE EFFICIENCY

## **This ENVIRO Berkeley Fireplace:**

- Has been certified for use with either natural or propane gases. (See rating label.)
- Is not for use with solid fuels.
- Is approved for bedroom or bed sitting room. (**IN CANADA:** must be installed with a listed wall thermostat. **IN USA:** see current ANSI Z223.1 for installation instructions.)
- Must be installed in accordance with local codes. If none exist, use current installation code CAN/CGA B149.1 in Canada or ANSI Z223.1/NFPA 54 in the USA.
- Must be properly connected to an approved venting system and not connected to a chimney flue serving a separate solid-fuel burning appliance.

**IMPORTANT NOTICE (Regarding first fire up):** When the unit is turned on for the first time, it should be turned onto high without the fan on for the first 4 hours. This will cure the paint, logs, gasket material and other products used in the manufacturing process. It is advisable to open a window or door, as the unit will start to smoke and can irritate some people. After the unit has gone through the first burn, turn the unit off including the pilot, let the unit get cold then remove the glass door and clean it with a good gas fireplace glass cleaner, available at your local ENVIRO dealer.



# SPECIFICATIONS

## DIMENSIONS:

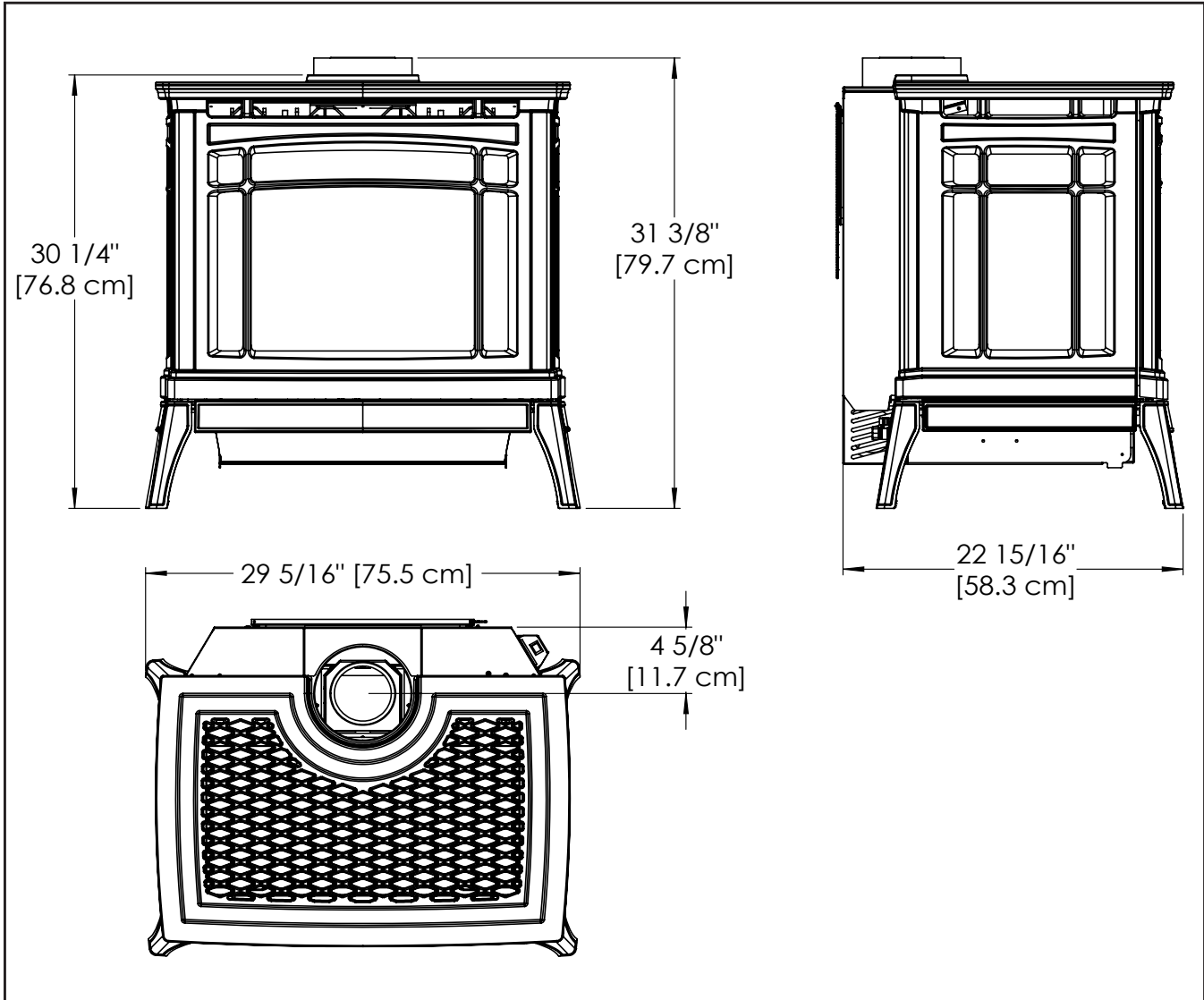

Figure 1. Berkeley Dimensions

## RATING LABEL & LIGHTING INSTRUCTIONS LOCATION:

The rating label and lighting instructions are located on a plate hanging on the back of of the unit.



# OPERATING INSTRUCTIONS

## For Your Safety, Read Safety Precautions And Lighting Instructions Before Operating

**WARNING: IF YOU DO NOT FOLLOW THESE INSTRUCTIONS EXACTLY A FIRE OR EXPLOSION MAY RESULT, CAUSING PROPERTY DAMAGE, PERSONAL INJURY OF LOSS OF LIFE.**

### LIGHTING AND TURNING OFF INSTRUCTIONS:

**FOR YOUR SAFETY READ BEFORE OPERATING**

**WARNING:** IF YOU DO NOT FOLLOW THESE INSTRUCTIONS EXACTLY, A FIRE OR EXPLOSION MAY RESULT CAUSING PROPERTY DAMAGE, PERSONAL INJURY OR LOSS OF LIFE.

A. This appliance is equipped with an ignition device which automatically lights the pilot. Do not try to light the pilot by hand.

B. BEFORE OPERATING smell all around the appliance area for gas. Be sure to smell next to the floor because some gas is heavier than air and will settle on the floor.

WHAT TO DO IF YOU SMELL GAS:

- Do not try to light any appliance.
- Do not touch any electrical switch; do not use any phone in your building.
- Immediately call your gas supplier from a neighbor's phone. Follow the gas supplier's instructions.
- If you cannot reach your gas supplier, call the fire department.

C. Use only the remote supplied with this fireplace. Never use tools, don't try to repair it, call a qualified service technician. Force or attempted repair may result in a fire or explosion.

D. Do not use this appliance if any part has been under water. Immediately call a qualified service technician to inspect the appliance and to replace any part of the control system and any gas control which has been under water.

**OPERATING INSTRUCTIONS**

1. STOP! Read the safety information above on this label.
2. Read the owner's manual including the section on "Remote Control" operation.
3. Turn off all electric power to the appliance.
4. Do not attempt to light the pilot by hand.
5. Wait five (5) minutes to clear out any gas. Then smell for gas, including near the floor. If you smell gas, STOP! Follow "B" in the safety information above on this label. If you don't smell gas, go to the next step.
6. Turn on all electric power to the appliance.
7. Using the remote control, press the ON/OFF key on the remote. "ON" will be indicated on the display of the remote and an audible "beep" will be heard at the unit to indicate the command has been received.

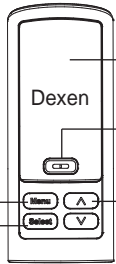

Dexen

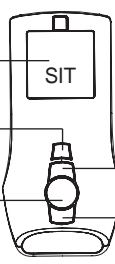

SIT

8. If the appliance will not operate, follow the instructions "To Turn Off Gas To Appliance" and call your service technician or gas supplier.

**TO TURN OFF GAS TO APPLIANCE**

1. Set thermostat to lowest setting, or press the ON/OFF or Power Key. "OFF" will be indicated on the display and an audible "Beep" will be heard at the unit to indicate the command has been received.
2. Turn off all electric power to the appliance if service is to be performed.

C-16320

Figure 2. Lighting Instruction Label

# OPERATING INSTRUCTIONS

## AIR SHUTTERS:

Behind the valve access door is the air shutter adjustment levers on the right hand side of the venturi box (see Figure 4) above the control panel. The air shutters allow the amount of air coming into the fireplace to be adjusted in order to accommodate different climates and venting arrangements. The left shutter adjusts the rear burner and the right shutter adjusts the front burner. Start the pilot and then the burner. Make sure the pilot flame is burning normally and none of the burner ports are plugged. Let the fireplace burn for roughly fifteen minutes and then examine the flames, compare the flames to Figure 50.

The ideal flame will be blue at the base and light orange above. The flames should be of medium height. If the flames look like this, no venturi adjustment is needed. If the flames are fairly short and mostly blue,

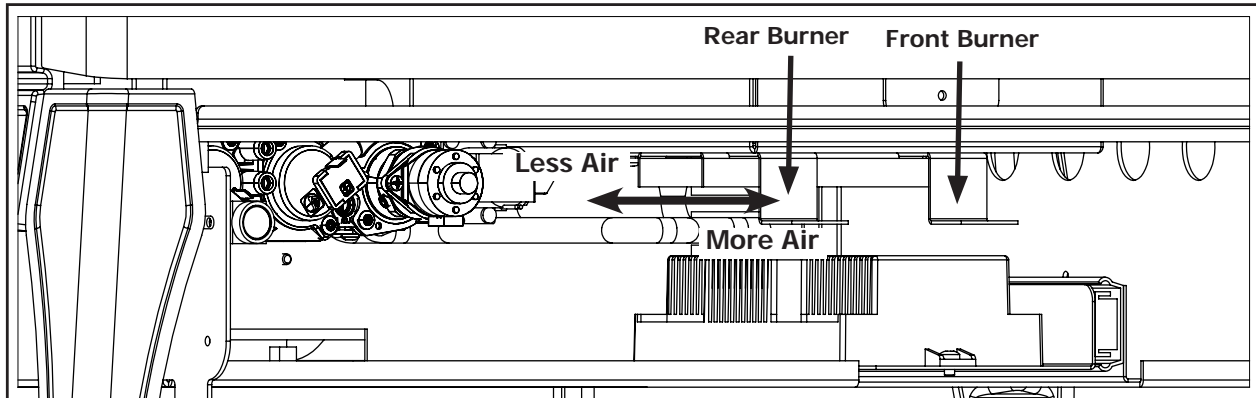

Figure 4. Air shutter adjustment lever.

the fireplace is getting too much air. Therefore, the air shutter should be closed (pushed in) slightly until the correct flames are achieved. Flames that are very orange, with tall, dark, stringy tips, are not getting enough air. Open (pull out) the venturi until the flames clean up. If the shut is opened, or closed all the way, and the correct flames cannot be attained, turn off the gas and contact the dealer.

**Warning:** Incorrect shutter adjustment may lead to improper combustion, which is a safety hazard. Contact the dealer if there is any concern about the venturi adjustment.

## NORMAL SOUNDS DURING OPERATION:

Table 1: Normal Sounds

Component	Sound & Reason
Berkeley	Creaking when heating up or cooling down.
Burner	Light pop or poof when turned off; this is more common with LP units.
Temperature Sensor	Clinking when it senses to turn the blower on or off.
Pilot Flame	Quiet whisper while the pilot flame is on.
Blower / Fan	Air movement that increase and decreases with the speed of the blower. The blower is pushing the heat from the fireplace into the room.
Gas Control Valve	Dull click when turning on or off, this is the valve opening and closing.

## REMOTE CONTROL OPERATIONS:

Proflame 2 is a modular remote control system that directs the functions of the Berkeley. The Proflame 2 TMFSLA is configured to control the on/off main burner operation, its flame levels and provides on/off and Smart thermostatic control of the appliance. The system also controls the fan speed through six (6) levels and can turn off the front burn independently.



# OPERATING INSTRUCTIONS



**For Berkeley-D models refer to the separate Dexen user manual supplied for remote control operations.**

## SYSTEM DESCRIPTION:

The Proflame 2 Remote Control System consists of two (2) elements:

1. Proflame 2 Transmitter.
2. Integrated Fireplace Controller (IFC) and wiring harness to connect to the gas valve, stepper motor battery holder, convection fan, and lights.

## ATTENTION!

- TURN "OFF" THE MAIN GAS SUPPLY OF THE APPLIANCE DURING INSTALLATION OR MAINTENANCE OF THE IFC.
- TURN "OFF" MAIN GAS SUPPLY TO THE APPLIANCE PRIOR TO REMOVING OR REINSERTING THE BATTERIES IN THE BATTERY HOLDER

## TECHNICAL DATA

### Transmitter (Remote Control):

Supply voltage: 4.5 V (three 1.5 V AAA batteries)  
Radio frequency: 315 MHz

### Integrated Fireplace Controller (IFC):

Supply voltage: AC IN - 120 V / 60 Hz  
Battery Backup IN - 6 Vdc - 200mA (four 1.5 V AA batteries)  
Spark voltage / frequency: >10kV / 1Hz  
Comfort modulating fan: 120 V / 60 Hz / 2A  
Auxiliary: 120 V / 60 Hz / 5A

## TRANSMITTER:

The Proflame 2 Transmitter is a black remote control with a blue backlit LCD display. It uses a streamline design with a simple button layout and informative LCD readout (Figure 5). The Transmitter is powered by three (3) AAA type batteries. A Mode Key is provided to Index between the features and a Thermostat Key is used to turn on/off or index through Thermostat functions (Figure 5 & 6)



**Figure 5: Proflame 2 Transmitter.**

# OPERATING INSTRUCTIONS

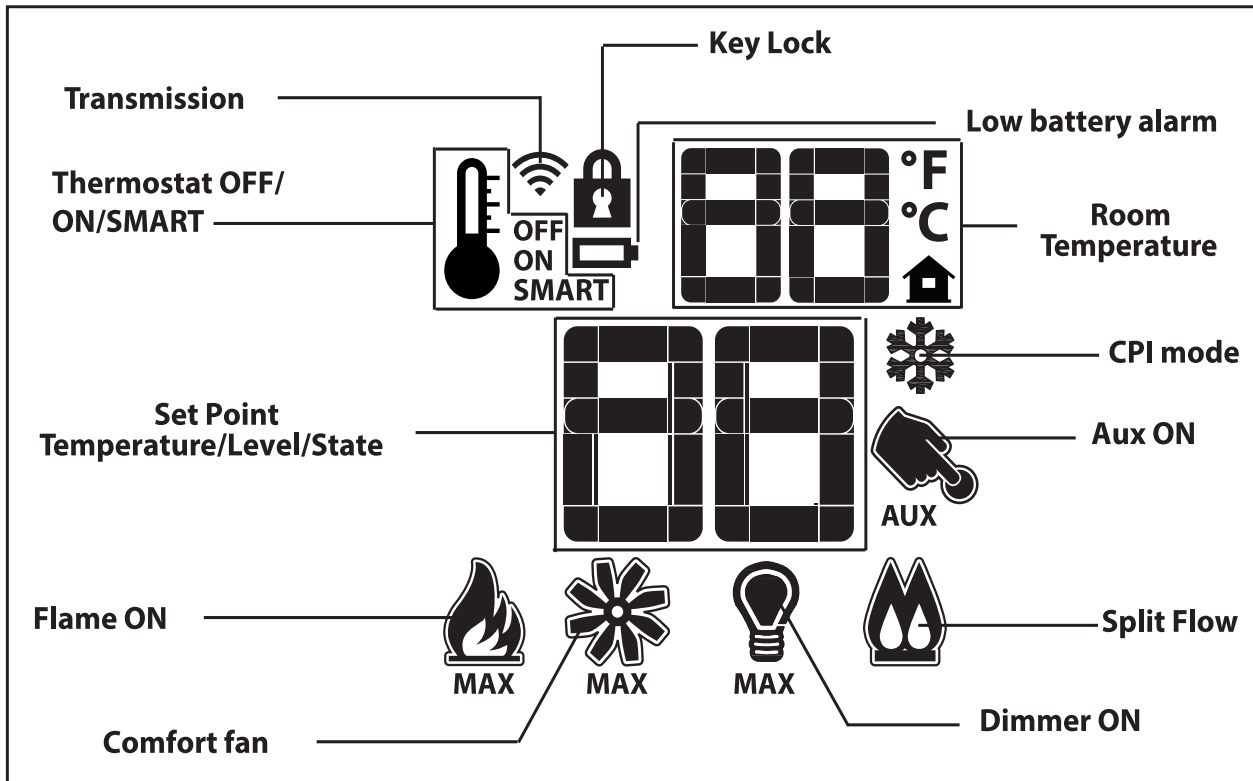

Figure 6: Proflame 2 Transmitter LCD Screen.

## INTEGRATED FIREPLACE CONTROLLER (IFC):

The Proflame 2 IFC (Figure 7) connects directly to the gas valve, split flow valve, stepper motor, pilot and convection fan with a wiring harness. The IFC is mainly powered by 120 VAC but can also run off a battery backup four (4) AA type batteries for shorter periods of time. The IFC accepts commands via radio frequency from the Transmitter to operate the appliance in accordance with the particular Proflame 2 system configuration. The IFC has a red reset button at the front right corner that is used to synchronize the Transmitter when using the for the first time, or after the batteries have been replaced.

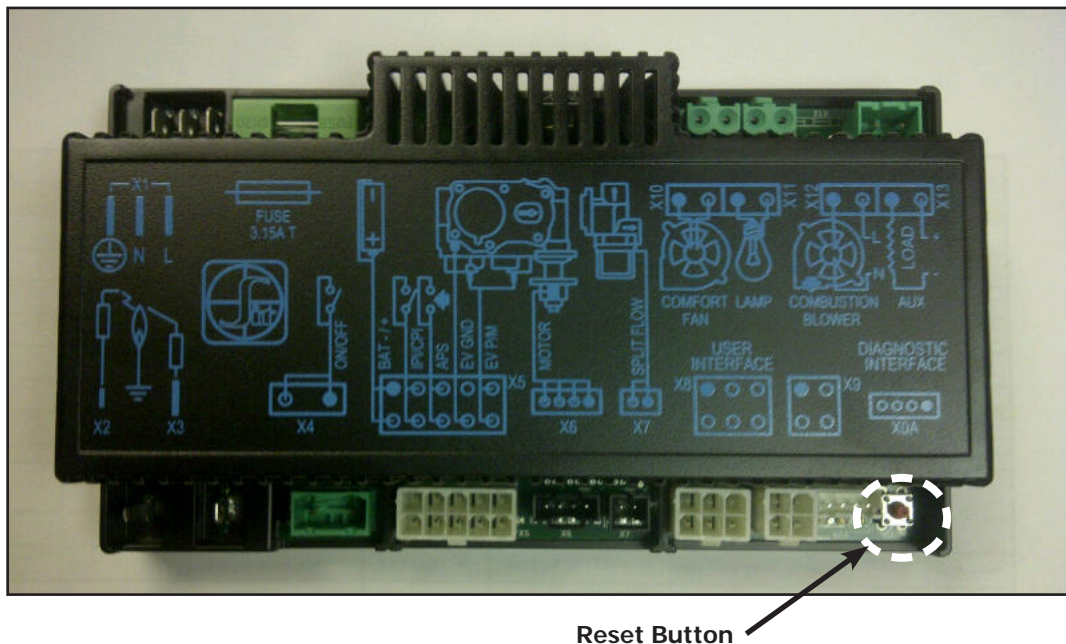

Figure 7: Integrated Fireplace Controller

# OPERATING INSTRUCTIONS

## OPERATING PROCEDURE:

### Initializing The System For The First Time

Install the four (4) AA batteries into the IFC battery holder. Note the polarity of the battery and insert into the battery bay as indicated on the body of the battery holder. Press the reset button on the IFC marked "SW1" (see Figure 7).

The IFC will "beep" three (3) times to indicate that it is ready to synchronize with a Transmitter. Install the three (3) AAA type batteries in the Transmitter battery bay, located on the base of the Transmitter. With the batteries already installed in the Transmitter, push the 'ON' button. The IFC will "beep" four (4) times to indicate the Transmitter's command is accepted and sets to the particular code of that Transmitter. The system is now initialized.

### **Temperature Indication Display**

With the system turned OFF, press the Thermostat Key and the Mode Key at the same time. Look at the LCD screen on the transmitter to verify that a °C or °F is visible to the right of the Room Temperature display (see Figure 8).

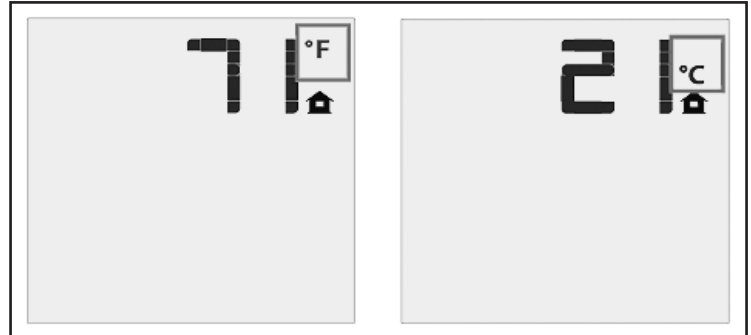

**Figure 8: Remote Control Display in Farenheit and Celcius.**

### **Turn on the Appliance**

Press the ON/OFF Key on the Transmitter. The Transmitter display will show all active Icons on the screen. A single "beep" from the IFC will confirm reception of the command and will commence to first ignite the pilot light, followed by the main burner. This should take about 10 seconds to complete.

## SWITCHING TO CONTINUOUS PILOT MODE:

When the Berkeley is turned off press the mode key to index to the constant pilot (CPI) mode icon (see figure 9). Pressing the up arrow key will select Continuous Pilot Ignition (CPI) and pressing the down arrow key will return to IPI. Once a selection is made the IFC will beep once to confirm it had received the command. **NOTE: It is recommended to use the continuous pilot mode during the winter when the outside temperature is below 50°F (10°C) to keep the chimney properly heated for updraft during burner ignition.** Continuous pilot mode also keeps the firebox warm which eliminates both heat loss to cold air that is trapped inside the firebox as well as excessive exhaust vapour condensation on the door glass.

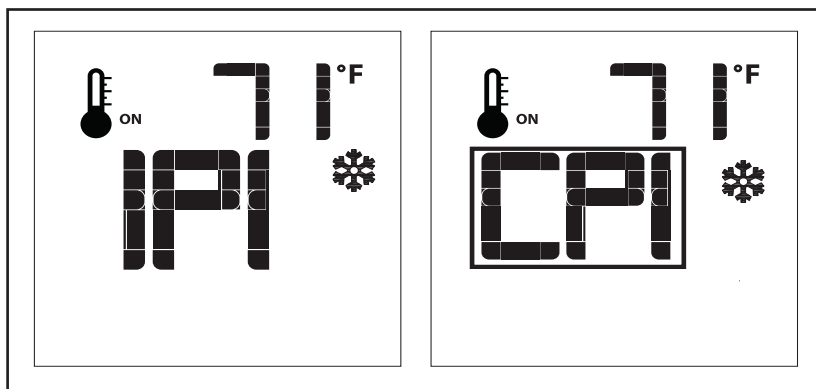

**Figure 9: CPI Pilot Mode.**

# OPERATING INSTRUCTIONS

## Turn off the Appliance

Press the ON/OFF Key on the Transmitter. The Transmitter LCD display will only show the room temperature and Icon (see Figure 8). A single “beep” from the IFC confirms reception of the command and both the pilot light (if the unit is not set to continuous pilot) and main burner will turn off.

## Room Thermostat (Transmitter Operation)

The Remote Control can operate as a room thermostat. The thermostat can be set to a desired temperature to control the comfort level in a room. To activate this function, press the Thermostat Key (see Figure 5). The LCD display on the Transmitter will change to show that the room thermostat is “ON” and the set temperature is now displayed (see Figure 10). To adjust the set temperature, press the Up or Down Arrow Keys until the desired set temperature is displayed on the LCD screen of the Transmitter.

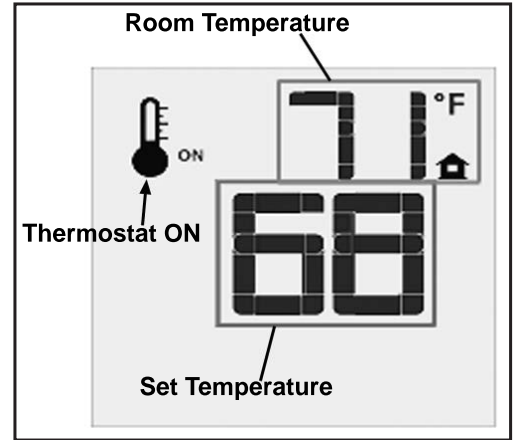

Figure 10: Remote Control Displays Set Temperature.

## Smart Thermostat (Transmitter Operation)

The Smart Thermostat function adjusts the flame height in accordance to the difference between the set point temperature and the actual room temperatures. As the room temperature gets closer to the set point the Smart Function will modulate the flame down. To activate this function, press the Thermostat Key (Figure 5) until the word “SMART” appears to the right of the temperature bulb graphic (Figure 11). To adjust the set temperature, press the Up or Down Arrow Keys until the desired set temperature is displayed on the LCD screen of the Transmitter.

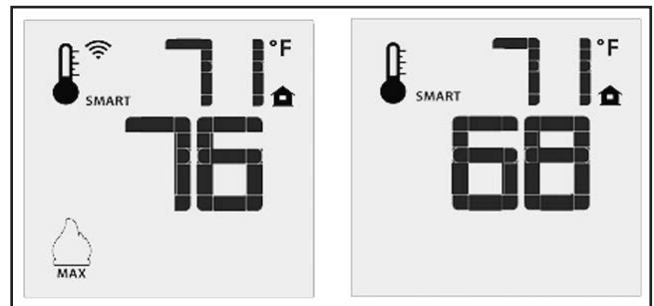

Figure 11: Remote Control's Smart Flame Function.

## Remote Flame Control

The Proflame 2 remote control system has six (6) flame levels. With the system on, and the flame level at the maximum in the appliance, pressing the Down Arrow Key once will reduce the flame height by one step until the flame is turned off. The Up Arrow Key will increase the flame height each time it is pressed. If the Up Arrow Key is pressed while the system is on but the flame is off, the flame will come on in the high position (refer to Figure 12). A single “beep” will confirm reception of the command.

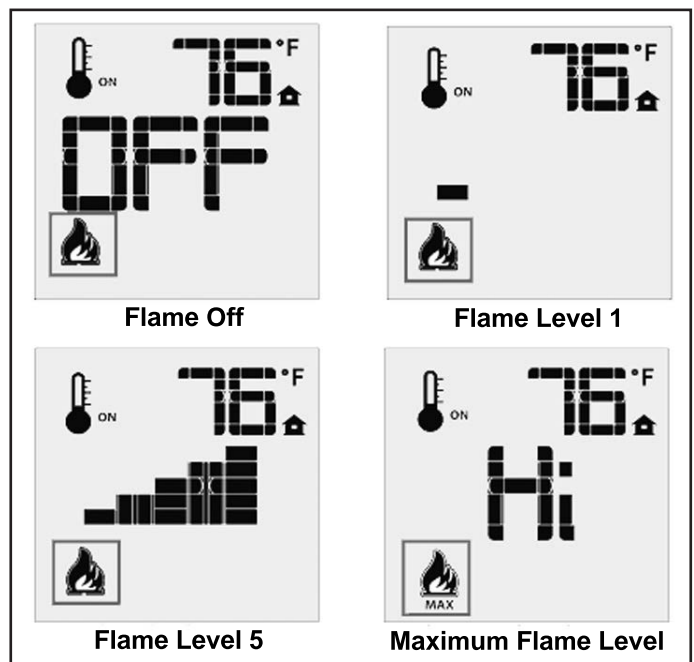

Figure 12: Remote Control's Flame Levels.

# OPERATING INSTRUCTIONS

## Split Flow Operation

The split flow operation on the Berkeley turns off the front section of the burner, greatly reducing the heat output of the unit. If you'd like to have the fireplace on but would not like to have as much heat in the room, you can turn off this function. Press the Mode key of your remote repeatedly until the double flame icon is lit up (refer to Figure 13). By pressing the up or down key, turn the rear split valve to "on" or "off". The front flame on the burner will turn on and off. This does not affect the flame setting of the remaining flame. Turning off the front section of this burner may result in an extinguishing "pop", particularly if your fireplace is operating on propane gas, this is normal.

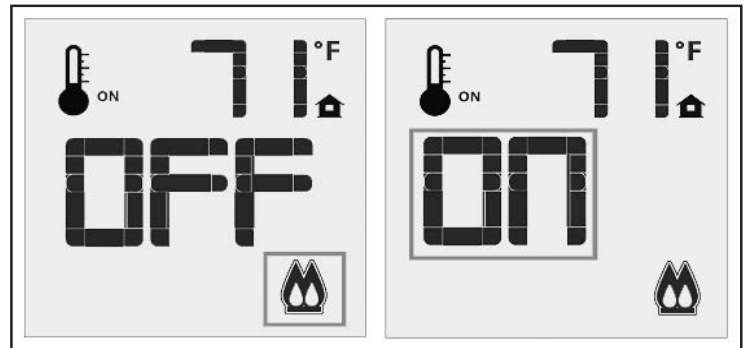

Figure 13: Split Flow Control

## Fan Control

The Berkeley comes with a convection fan that can be controlled with the Transmitter. The fan speed can be adjusted through six (6) speeds. To control the fan press the Mode key (Figure 5) to index to the fan control icon (Figure 14). Use the UP/DOWN arrow keys to turn on, off, or adjust the fan speed (Figure 14). A single beep from the IFC will confirm the command has been received

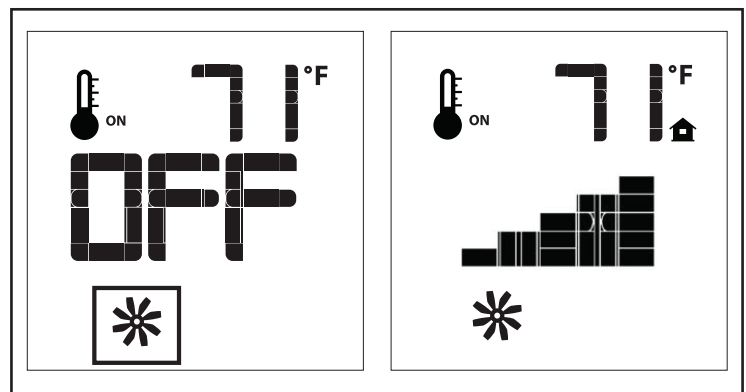

Figure 14: Fan Control

## Auxiliary Control

This function is not used on the Berkeley and can be disregarded.

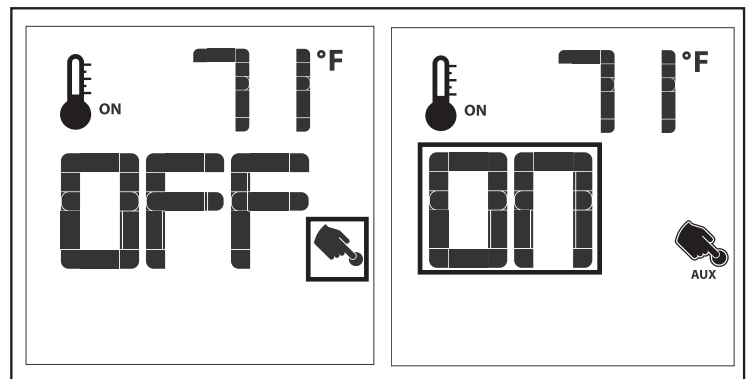

Figure 15: Auxiliary Control (not used)

## Dimmer Control

This function is not used on the Berkeley and can be disregarded.

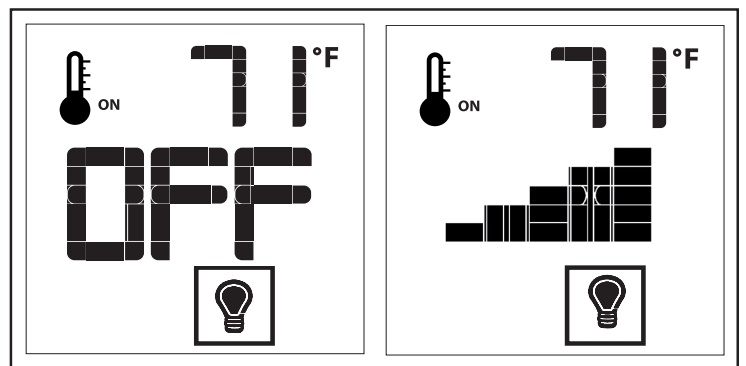

Figure 16: Dimmer Control (not used)

# OPERATING INSTRUCTIONS

---

## Key lock

This function will lock the keys to avoid unsupervised operation. To activate this function, press the Mode and UP keys at the same time and the a lock will appear (see Figure 17). To de-activate this function, press the Mode and UP Keys at the same time.

## Low Battery Power Detection

**Transmitter:** The life span of the remote control batteries depends on various factors: quality of the batteries used, the number of ignitions of the appliance, the number of changes to the room thermostat set point etc. When the Transmitter batteries are low, a Battery Icon will appear on the LCD display of the Transmitter (see Figure 18) before all battery power is lost. When the batteries are replaced this icon will disappear.

**IFC:** The life span of the IFC batteries depends on various factors during a prolonged power outage: quality of the batteries used, the number of ignitions of the appliance, the number of changes to the room thermostat set point etc. When the IFC batteries are low, No "beep" will be emitted when it receives an On/Off command from the Transmitter. This is an alert for a low battery condition for the IFC. When the batteries are replaced the "beep" will be emitted from the IFC when the ON/OFF Key is pressed (See INITIALIZING THE SYSTEM FOR THE FIRST TIME).

**WARNING: Fire Hazard. Can cause severe injury or death. The Transmitter causes ignition of the appliance. The appliance can turn on suddenly. Keep away from the appliance burner when operating the remote system.**

**WARNING: Shock Hazard. Can cause severe injury or death. This device is powered by line voltage. Do not try to repair this device. In no way is the enclosure to be tampered with or opened. Disconnect from line voltage before performing any maintenance.**

**CAUTION: Property Damage Hazard. Excessive heat can cause property damage. The appliance can stay lit for many hours. Turn off the appliance if it is not going to be attended for any length of time. Always place the Transmitter where children cannot reach it.**

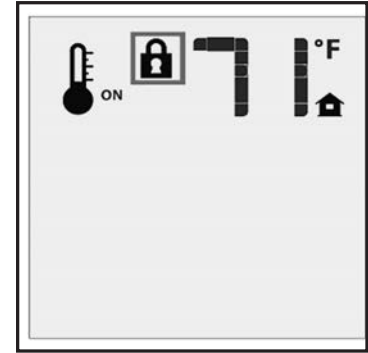

Figure 17: Key Lock

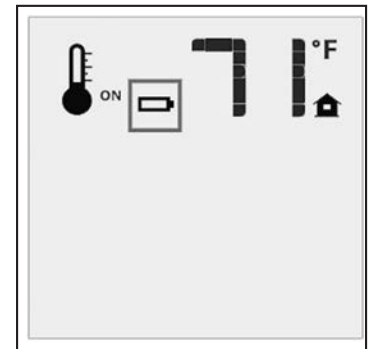

Figure 18: Low Battery

## MAINTENANCE AND SERVICE

---

### ROUTINE MAINTENANCE:

---

At least once a year, run through the following procedures to ensure the system is clean and working properly. Check the burner to see if all the ports are clear and clean. Check the pilot to make sure it is not blocked by anything. The pilot flame should be blue with little or no yellow on the tips.

**Warning:** Clearances must be sufficient to allow access for maintenance and service

**Warning:** Failure to position the parts in accordance with this manual, or failure to use only parts specifically approved with this appliance may result in property damage or personal injury.

The venting system must be periodically examined; it is recommended the examination is done by a qualified agency.

### CLEANING DECORATIVE SURFACES:

---

Painted, powder coated, or porcelain enameled surfaces should be wiped with a damp cloth periodically. Never clean the face when it is hot. Do not use other cleaners as they may leave a residue, which can become permanently etched into the surface.



# MAINTENANCE AND SERVICE

---

## CLEANING THE GLASS:

---

**When the fireplace has cooled**, remove the face of the fireplace along with the glass. See MAINTENANCE AND SERVICE - GLASS DOOR REMOVAL. Check the gasket material on the back of the glass, making sure that it is attached and intact.

During a cold start up, condensation will sometimes form on the glass. This is a normal condition with all fireplaces. However, this condensation can allow dust and lint to cling to the glass surface. Initial paint curing of the appliance can leave a slight film behind the glass, a temporary problem. The glass will need cleaning about two weeks after installation. **Use a mild glass cleaner and a soft cloth. Abrasive cleaners will damage the glass and painted surfaces.** Depending on the amount of use, the glass should require cleaning no more than two or three times a season. **Do not clean the glass when it is hot.**

## CLEANING THE FIREBOX:

---

Remove the logs carefully, as they are very fragile. Carefully clean any dust off the logs and remove any lint from the burner and pilot. At this time, inspect the ceramic burner for cracking. If a problem is suspected, contact the dealer. Check the logs for deterioration or large amounts of soot; a small amount on the bottom side of the logs is normal. Replace the logs as shown in the SECONDARY INSTALLATION - LOG SET INSTALLATION section. If any logs are damaged, contact your nearest ENVIRO dealer.

## REPLACING THE GLASS:

---

The glass in the fireplace is a high temperature ceramic. If the glass is damaged in any way, a factory replacement is required (see PARTS LIST). Wear gloves when handling damaged glass door assembly to prevent personal injury. Do not operate with the glass front removed, cracked or broken. Removal and replacement of the glass from the door **must** be done by a licensed or qualified service person. **The glass must be purchased from an ENVIRO dealer. No substitute materials are allowed.** Remove the door (see page 16). The replacement glass will come with a new gasket installed. Remove any silicone remnants from the door. Apply high temperature silicone to the two vertical faces of the door and install the new piece of glass with gasket (be sure to maintain edge clearances). Apply even pressure to the glass to allow the silicone to adhere to the gasket material.

## FLASHOUT GUARD:

---

This unit is equipped with a flashout guard that automatically stands up to serve as protection if a delayed ignition were ever to occur. The flashout guard should always be in the down position (Figure 19) during regular operation of the stove. If the guard is for some reason left in the up position (Figure 20) it will effect the volume of convective air discharging from the front of the stove and must be reset to the down position.

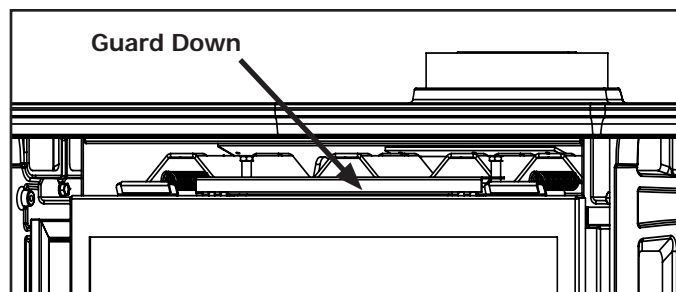

Figure 19: Flashout Guard Down (Default)

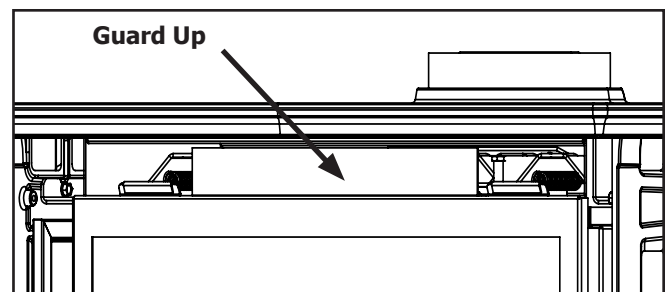

Figure 20: Flashout Guard Up

# MAINTENANCE AND SERVICE

## CAST DOOR REMOVAL:

The cast door on the Berkeley needs to be removed whenever access to the firebox is required. First the Berkeley must be turned off and allowed to fully cool. Next, remove the Cast Top as shown in Figure 21 by simply lifting up. Lay the cast top down on a towel or blanket to prevent scratching of the finish. The cast door, with safety screen attached, can now be removed by first pulling the bottom out then lifting up to unhook the top. Lay the door face down on a towel or blanket to prevent scratching of the finish. To re-install the cast door simply reverse the procedure.

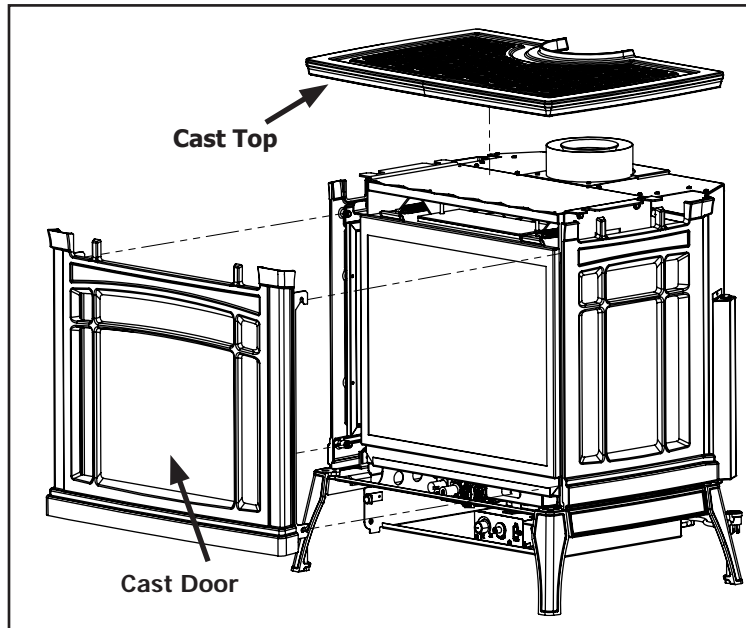

Figure 21. Cast Door Removal

## GLASS DOOR REMOVAL:

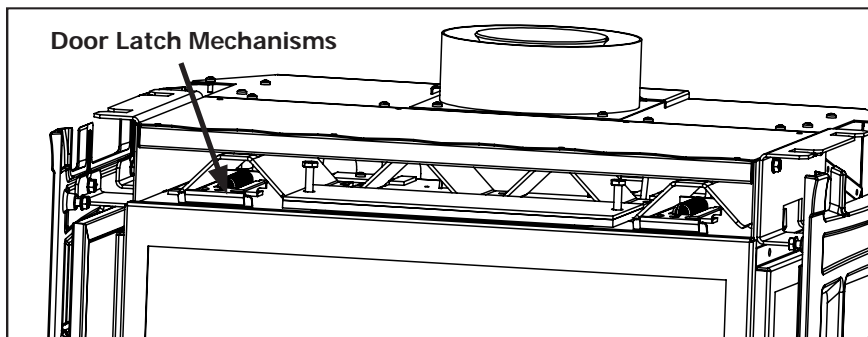

Figure 22. Top latches for glass door (cast top and door removed)

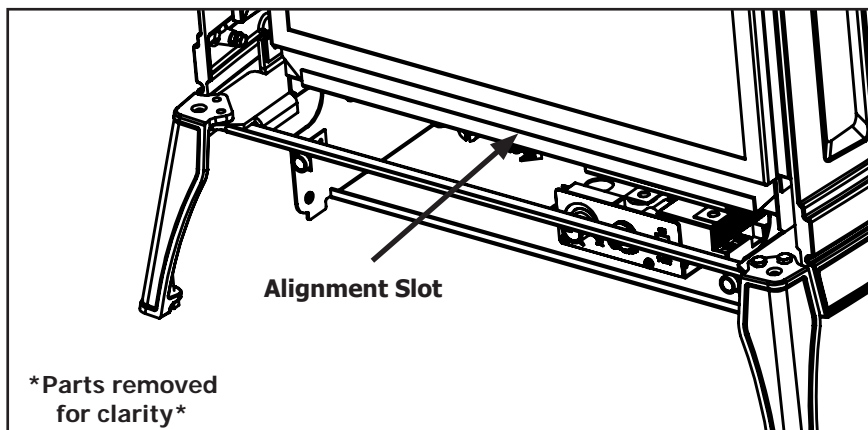

Figure 23. Bottom Alignment Slot for glass door.

In order to install the log set, and for regular cleaning, the glass door must be removed. The cabinet front must first be removed, as outlined in the section above, before accessing the door latches. There are two (2) door latch mechanisms on top the glass door as shown in Figure 22. Each latch can be pulled straight out and up by hand. When the top latches are unhooked, the door can be lifted up out of the alignment slot at the bottom of the firebox, shown in Figure 23.

To replace the glass door, simply reverse the above procedure.

**Warning:** Do not touch or attempt to remove the glass door if the fireplace is not completely cold.

**WARNING:** Never operate the fireplace with the glass door removed.

# MAINTENANCE AND SERVICE

## BURNER REMOVAL:

The burner may need to be removed for a few reasons, including cleaning under the burner, converting the unit to a different gas type, or to replace the burner altogether. **Proceed only when the unit has completely cooled down.**

1. Remove the cabinet front, and glass door as outlined in the MAINTENANCE AND SERVICE - GLASS DOOR REMOVAL.
2. Remove the log set as shown in SECONDARY INSTALLATION - LOG SET INSTALLATION
3. Place your hands in the air slots in the burners, as shown in figure 25, then pull forward and lift up to dis-engage the venturi tubes.
4. Continue to lift up and rotate the burner approx. 45 degrees, as shown in Figure 26, and remove it from the firebox. Take care not to damage the edges of the ceramic burner as it is fragile.

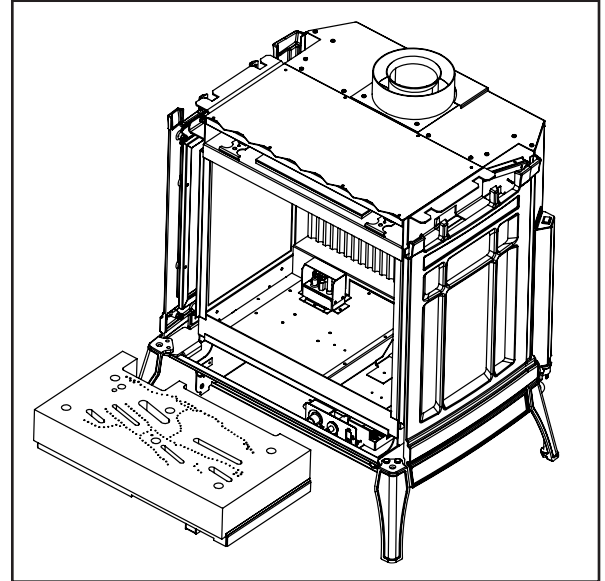

Figure 24. Removing Burner.



Figure 25. Burner Removal - Correct Hand Placement



Figure 26. Burner Removal - Rotate 45 degrees

To re-install the burner follow steps 1-4 in reverse. When placing the burner back in the unit make sure it is properly seated and up against the intake plenum at the rear of the firebox. When installed correctly the burner will have no side to side movement.

# MAINTENANCE AND SERVICE

## FUEL CONVERSION:

### TO BE INSTALLED BY A QUALIFIED SERVICE AGENCY ONLY

Please read and understand these instructions before installing.

**Warning: This conversion kit shall be installed by a qualified service agency in accordance with the manufacturer's instructions and all applicable codes and requirements of the authority having jurisdiction. If the information in these instructions is not followed exactly, a fire, explosion or production of carbon monoxide may result causing property damage, personal injury or loss of life. The qualified service agency is responsible for the proper installation of this kit. The installation is not proper or complete until the operation of the converted appliance is checked as specified in the manufacturer's instructions supplied with the kit.**

#### Kit Parts List for all Berkeley models:

- 2 - Orifice (NG: #45 & #44) or (LP: 2 x #55 , 1 x #56)
- 1 - LP Pilot Orifice
- 1 - Servo Regulator with diaphragm
- 1 - Installation instruction sheet
- 1 - Conversion label

Carefully inspect all parts supplied with this conversion kit. If any parts have been damaged or are missing, contact your dealer, distributor or courier company to have them replaced before starting this installation.

#### Conversion Kit Installation:

1. Turn the unit off by pressing the ON/OFF Key on the remote and shut off gas supply at the shut-off valve upstream of the unit. CAUTION: The gas supply must be shut off prior to disconnecting the electrical power and before proceeding with the conversion. Allow the valve and unit to cool down to room temperature.
2. Remove the glass door as shown in the MAINTENANCE AND SERVICE - GLASS DOOR REMOVAL.
3. Carefully remove the log set.
4. Remove the burner as shown in the MAINTENANCE AND SERVICE - BURNER REMOVAL.
5. Convert the pilot orifice (see Figure 27):
  - a) Using a  $\frac{7}{16}$ " wrench, loosen the pilot head counter clockwise and remove
  - b) Remove the existing orifice and replace with the one supplied in the kit (Figure 27)
  - c) Re-install the pilot head and tighten until it is back in the proper position (Figure 28)
6. Convert the burner orifices:
  - a) Remove the main burner orifices with a  $\frac{3}{8}$ " socket
  - b) Put a bead of pipe-thread sealant into the orifice mount. DO NOT OVER-TIGHTEN
  - c) Install new orifices.



**Figure 27: Pilot Orifice**

## MAINTENANCE AND SERVICE

7. Convert the SIT gas valve:
  - a) Use a T-20 driver to remove the two screws that hold the servo regulator to the gas valve and disconnect the wire harness from the IFC.
  - b) Remove the rubber regulator diaphragm that is situated between the servo regulator and the valve body. The new servo regulator already has this diaphragm installed.
  - c) Install the LP servo regulator, with the new longer T-20 screws included in the kit and connect the harness to the IFC.
8. Reinstall the burner, fire grate, log set, and glass door. Also refer to SECONDARY INSTALLATION - LOG

SET INSTALLATION in your Owner's Manual. When re-installing the burner, ensure that the burner to pilot hood and shield relationship is similar to what is shown in Figure 28.

9. Reconnect the main gas line if it was disconnected and open the shut-off valve at the gas line to the unit.
10. Reconnect the electrical power to the unit.
11. Use a small brush to apply a warm soapy water solution to all gas connections (use a half dish soap and half warm water). If a gas leak is present, bubbling will occur. Gas leaks can be repaired by using an approved pipe thread sealant or approved Teflon tape. **NEVER USE AN OPEN FLAME WHEN TESTING FOR LEAKS.**



Figure 28. Correct Pilot

12. Relight the pilot and confirm the flame properly covers the flame sensor (see Figure 28). Should the pilot require adjustment, turn the adjustment screw (page 31) clockwise to decrease or counterclockwise to increase until the correct flame is achieved.
13. Relight the main burner in both the "HI" and "LO" positions to verify proper burner ignition, operation and proper flame appearance (figure 50, page 35). Confirm the inlet and manifold pressures are within the acceptable ranges as directed in section INTIAL INTALLATION - GAS LINE CONNECTION AND TESTING. **If the Berkeley has been installed at an altitude higher than 2000ft (610m) it is required to de-rate the unit accordingly. If converting to Propane use the supplied #56 orifice on the left :**

**In the USA:** The appliance may be installed at higher altitudes. Please refer to your American Gas Association guidelines which state: the sea level rated input of Gas Designed Appliances installed at elevations above 2000 (610 m) feet is to be reduced 4% for each 1000 feet (305 m) above sea level. Refer also to local authorities or codes which have jurisdiction in your area regarding the de-rate guidelines.

**In Canada:** When the appliance is installed at elevations above 4500 feet (1372 m), the certified high altitude rating shall be reduced at the rate of 4% for each additional 1000 feet (305 m).

14. MAKE SURE that the conversion label is installed on or close to the rating label to signify that the unit has been converted to a different fuel type.



# INITIAL INSTALLATION

## QUALIFIED INSTALLERS ONLY

### INTRODUCTION:

This section of the owner's manual is for the use of qualified technicians only. Fireplace placement, hearths, and venting terminations will be covered, as well as the gas and electrical systems. There are several installation safety guidelines that must be adhered to. Please carefully read the safety precautions at the front of this manual.

### PREPARATION FOR INSTALLATION:

- Remove the packaging from the appliance, and check to make sure there is no damage. If damage is found, please report it to both the carrier and your dealer as soon as possible.
- Before beginning, carefully check the glass door and the log set
- Locate a position where the flue system of the stove can be properly installed without damaging the integrity of the building; e.g. cutting a wall or ceiling joist.
- Check stove and flue system clearance requirements.
- Locate the stove where it can be accessed by a gas supply line.
- Locate the stove in a large and open room that is centrally located in the house. This will optimize heat circulation and comfort.
- As the Berkeley is equipped with a convection fan, ensure that an electrical outlet is within 6 ft (1.8 m) of the stove.
- The flow of combustion and ventilation air must not be obstructed.

### CLEARANCE TO COMBUSTIBLES:

**Warning:** Clearances must be sufficient to allow access for maintenance and service.

- |                                 |                 |
|---------------------------------|-----------------|
| A. Sidewall to unit             | 12" (30.5 cm)   |
| B. Backwall to unit             | 5.0" (12.7 cm)  |
| C. Corner to unit               | 7.43 (18.9 cm)  |
| D. Ceiling to unit              | 27.5" (69.8 cm) |
| E. Floor (hard wood & linoleum) | 0"              |

Note: When installing on a carpeted surface a hearth pad must be used.

### MINIMUM ALCOVE DIMENSIONS:

- |              |                   |
|--------------|-------------------|
| Width        | 52.0" (132.1 cm)  |
| Height       | 57.25" (145.4 cm) |
| Depth (Max.) | 42" (106.68 cm)   |

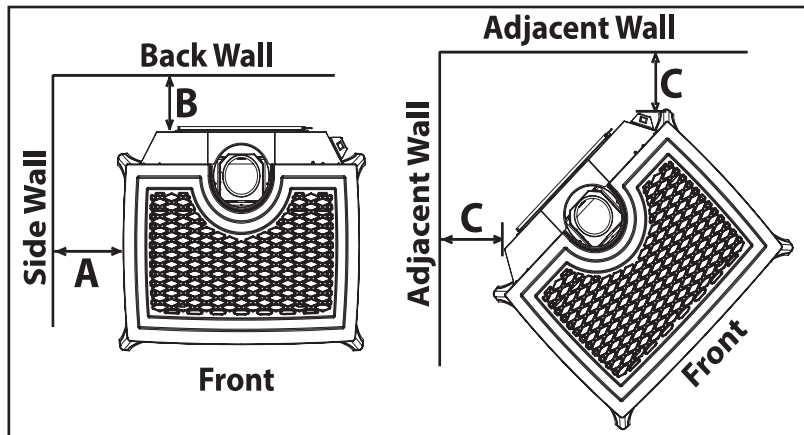

Figure 29 Clearance to Combustibles

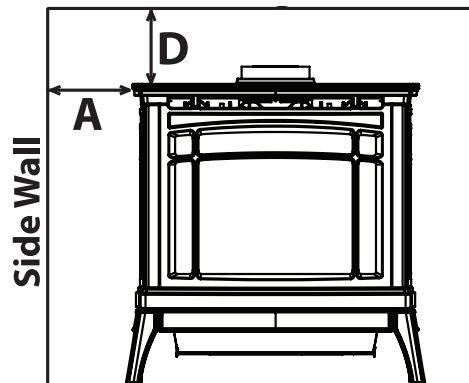

Figure 30 Clearance to Combustibles



# INITIAL INSTALLATION

## QUALIFIED INSTALLERS ONLY

### DIRECT VENT:

**WARNING: This appliance has been designed to draw room air for proper heat circulation from the bottom of the unit, and out the top front. Blocking or modifying these openings in any way can create hazardous situations.**

The vent length for the Berkeley must be between 36" (91 cm) and 44ft (13.4 m). This model is vented with co-axial 4" intake, 6 5/8" exhaust aluminum or stainless steel approved rigid vent leading into a vertical or horizontal termination cap. The flue collar of this model will fit inside of a standard 4" x 6 5/8" vent and must be either correctly interlocked or fastened, with three screws directly to the vent.

Check periodically that the vents are unrestricted. Also ensure that all direct vent pipes have been properly sealed and installed after routine inspection or cleaning. The air intake and exhaust pipes must be installed in the correct location on top of the Berkeley.

### VENTING CLEARANCES:

A 1" (25 mm) clearance to combustibles must be maintained around any vertical vent pipe. Around a horizontal vent pipe, the clearance to combustibles should be 2" (51 mm) above and 1½" (38 mm) on the sides and bottom. When combustible materials are directly above a 90° elbow, 3" (76 mm) of clearance are necessary.

**Table 2. Vent Pipe Minimum Clearances.**

	Vertical Pipe to the Side Walls	Horizontal Pipe to the Sides & Bottom	Above an Elbow Above the Unit	Above an Elbow Not Above the Unit	Above Horizontal Vent Pipe	Wall Frame 8" (203mm) or less
Hard Pipe	1" (25.4 mm)	1½" (38.1 mm)	3" (76.2 mm)	3" (76.2 mm)	2" (51 mm)	10"x10" (25x25cm)

A 10" (254 mm) x 10" (254 mm) frame (see Figure 31) will assure the proper support and spacing for the vent pipe as it passes through the wall. Installations in Canada require that a wall thimble be used for passing through walls and ceilings. All sealing and vapour barriers must comply with local building codes. The configuration of the venting pipes depends on the locations of walls, ceilings, and studs. However, the pipes cannot be of arbitrary length and arrangement. Because the length of the vertical and horizontal sections dramatically affects the burning efficiency of the fireplace, certain guidelines have been set in INITIAL INSTALLATION - ALLOWABLE VENT CONFIGURATIONS. Venting terminals can not be recessed into a wall or siding.

**WARNING: This gas appliance must not be connected to a chimney flue serving a separate solid-burning appliances.**

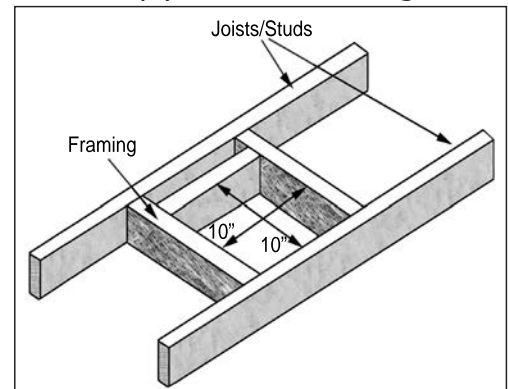

**Figure 31. Vent Framing For Wall or Ceiling.**

# INITIAL INSTALLATION

## QUALIFIED INSTALLERS ONLY

### APPROVED VENTING PARTS:

**Table 3: Approved Vent Manufacturers**

Manufacturer	Trade Name	Nominal Sizes
ICC	EXCELDirect	4" - 6 5/8"
M&G DuraVent	DirectVent Pro	4" - 6 5/8"

The Berkeley fireplace has been tested and certified for use with M&G DuraVent DirectVent Pro and ICC EXCELDirect venting systems. Refer to the table below for part numbers of commonly used parts for both venting systems. For more venting parts please visit the respective manufacturers' website.

**WARNING:** Do not mix parts from different vent manufacturers' systems.

**EXCEPTION TO WARNING:** This product has been evaluated by Intertek for using a DirectVent Pro starting collar in conjunction with EXCELDirect venting systems. Use of this system with the DirectVent Pro starting collar is deemed acceptable and does not affect the Intertek listing of the appliance.

**Table 4: Vent part numbers (Must state if galvanized or black wanted, PART NUMBERS).**

DirectVent Pro	EXCELDirect	Description
46DVA-06	DL6	6" Pipe Length
46DVA-09	DL9	9" Pipe Length
46DVA-12	DL1	12" Pipe Length
46DVA-18		18" Pipe Length
46DVA-24	DL2	24" Pipe Length
46DVA-36	DL3	36" Pipe Length
46DVA-48	DL4	48" Pipe Length
46DVA-60		60" Pipe Length
	DLA30	16 1/2" - 29", Adjustable
46DVA-24TA		17" - 24", Adjustable
46DVA-E45	4DE45	45° elbow
46DVA-E90	4DE90	90° elbow
46DVA-VSS	VSS	Vinyl siding standoff/sheild
46DVA-WT	4WT	Wall thimble
46DVA-SC	SC	Storm collar
46DVA-WFS	4CS	Fire stop
46DVA-WS	WS	Wall strap/support/band
46DVA-F6	4FA	Flashing, 0/12 to 7/12 roof pitch
46DVA-F7	4FB	Flashing, 8/12 to 12/12 roof pitch
46DVA-FF	4F	Flat flashing
46DVA-VCH	SVT	High wind vertical termination
46DVA-HC	HT	High wind horizontal termination
46DVA-KHC	4HTK	Horizontal termination kit
46DVA-KCA		Chimney Conversion Kit A (USA Only)
46DVA-KCA		Chimney Conversion Kit B (USA Only)
46DVA-KCA		Chimney Conversion Kit C (USA Only)

# INITIAL INSTALLATION

## QUALIFIED INSTALLERS ONLY

### HORIZONTAL TERMINATION - MINIMUM VENT LENGTH:

Refer to the figure for below for the minimum allowable venting setup for the Berkeley. A termination guard (50-3266) is required when the termination is within 7' (2.13m) of grade.

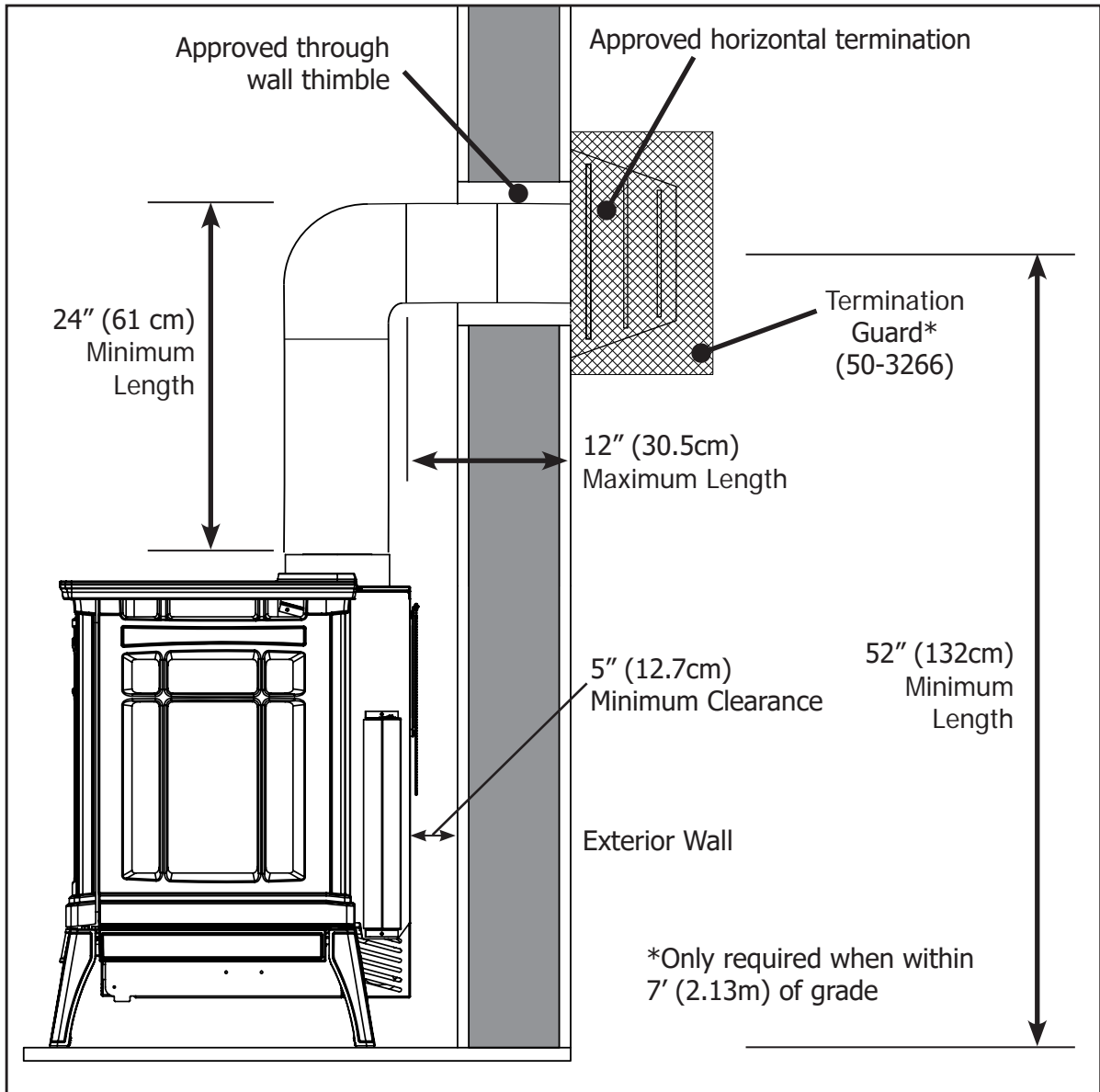
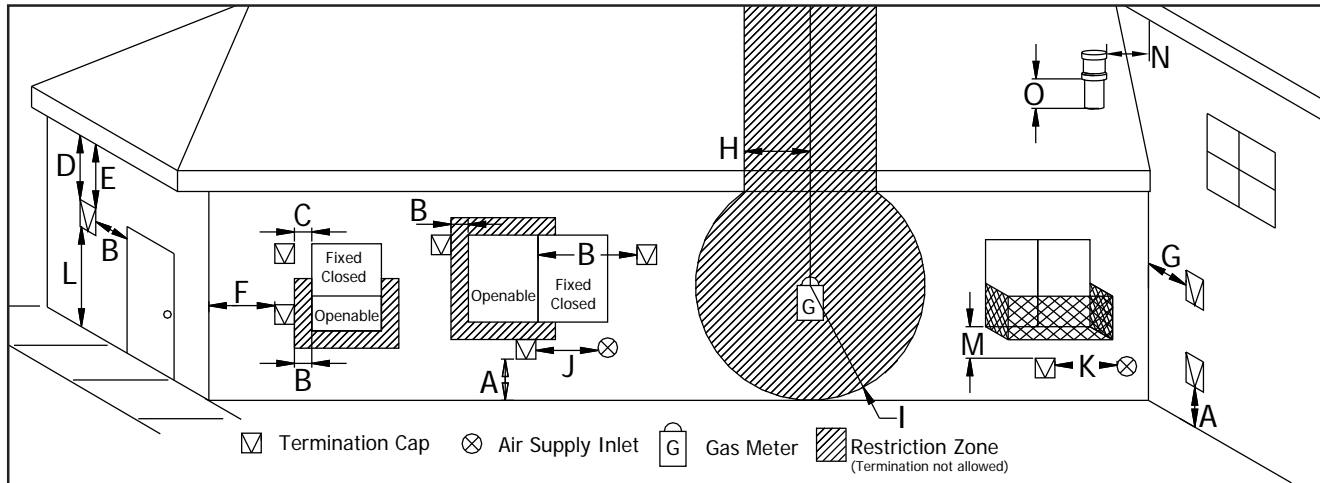

Figure 24. Minimum Vent Length

# INITIAL INSTALLATION

## QUALIFIED INSTALLERS ONLY

### VENT TERMINATION RESTRICTIONS:



**Figure 33. Vent Termination Restrictions, refer to Table 5.**

**Table 5: Vent termination clearances.**

Letter	Canadian Installation <sup>1</sup>	US Installation <sup>2</sup>	Description
A	12 in (30 cm)		Clearance above grade, verandah, porch, deck, or balcony.
B	12 in (30 cm)	9 in (23 cm)	Clearance from window or door that may be opened.
C	12 in (30 cm)*		Clearance from permanently closed window (to prevent condensation).
D	24 in (60 cm)*		Vertical clearance to ventilated soffit located above the terminal, within a horizontal distance of 2 ft (60 cm) from center line of terminal.
E	18 in (45 cm)		Clearance to unventilated soffit.
F	12 in (30 cm)*		Clearance to outside corner.
G	12 in (30 cm)*		Clearance to inside corner.
H	3 ft (91 cm) within a height of 15 ft (4.5 m) above the meter/regulator assembly	3 ft (91 cm) within a height of 15 ft (4.5 m) above the meter/regulator assembly*	Clearance to each side of center line extended above meter/regulator assembly.
I	3 ft (91 cm)		Radial clearance around service regulator vent outlet.
J	12 in (30 cm)		Clearance to non-mechanical air supply inlet to building, or the combustion air inlet to any other appliance.
K	6 ft (1.83 m)		Clearance to mechanical air supply inlet.
L	7 ft (2.13 m) <sup>†</sup>		Clearance above paved sidewalk or paved driveway located on public property.
M	18 in / 45 cm <sup>+</sup>		Clearance under verandah, porch, deck, or balcony.
N	12 in (30 cm)*		Clearance horizontally to any surface (such as an exterior wall) for vertical terminations.
O	12 in (30 cm)		Clearance above roof line for vertical terminations.

<sup>1</sup> In accordance with the current CSA B149, Natural Gas and Propane Installation Code.

<sup>2</sup> In accordance with the current ANSI Z223.1 NFPA 54, National Fuel Gas Code.

\* These numbers are only estimates.

<sup>†</sup> A vent shall not terminate directly above a side walk or paved driveway that is located between two single family dwellings and it serves both dwellings.

<sup>+</sup> Permitted only if verandah, porch, deck, or balcony is fully open on a minimum of two sides beneath the floor.

Clearances are in accordance with local installation codes and the requirements of the gas supplier.

**NOTE: Venting terminals shall not be recessed into walls or siding.**

# INITIAL INSTALLATION

## QUALIFIED INSTALLERS ONLY

### ALLOWABLE VENT CONFIGURATIONS:

Figures 34 show the range of possible vent configurations for vertical and horizontal terminations. Any layout that remains within the shaded areas is acceptable. Having the fewest number of elbows is ideal, as they tend to disrupt air movement. Using 45° elbows is preferable to using 90° elbows. Also, a shorter vent system will perform better than a longer one.

**The total length of horizontal vent pipe can not exceed 14 feet (4.27m) with one elbow in the horizontal plane, and the total vent length can not exceed 44ft (13.4m).** Any combination of rise and run can be used as long as it lays within the shaded area (a total of two (2) 90° elbows or four (4) 45° elbows can be used. In addition to what is shown, if a 90° elbow is used in the horizontal plane, 3 feet (91.4cm) must be subtracted from the allowable horizontal run (for each 45° elbow, 1½ feet must be subtracted).

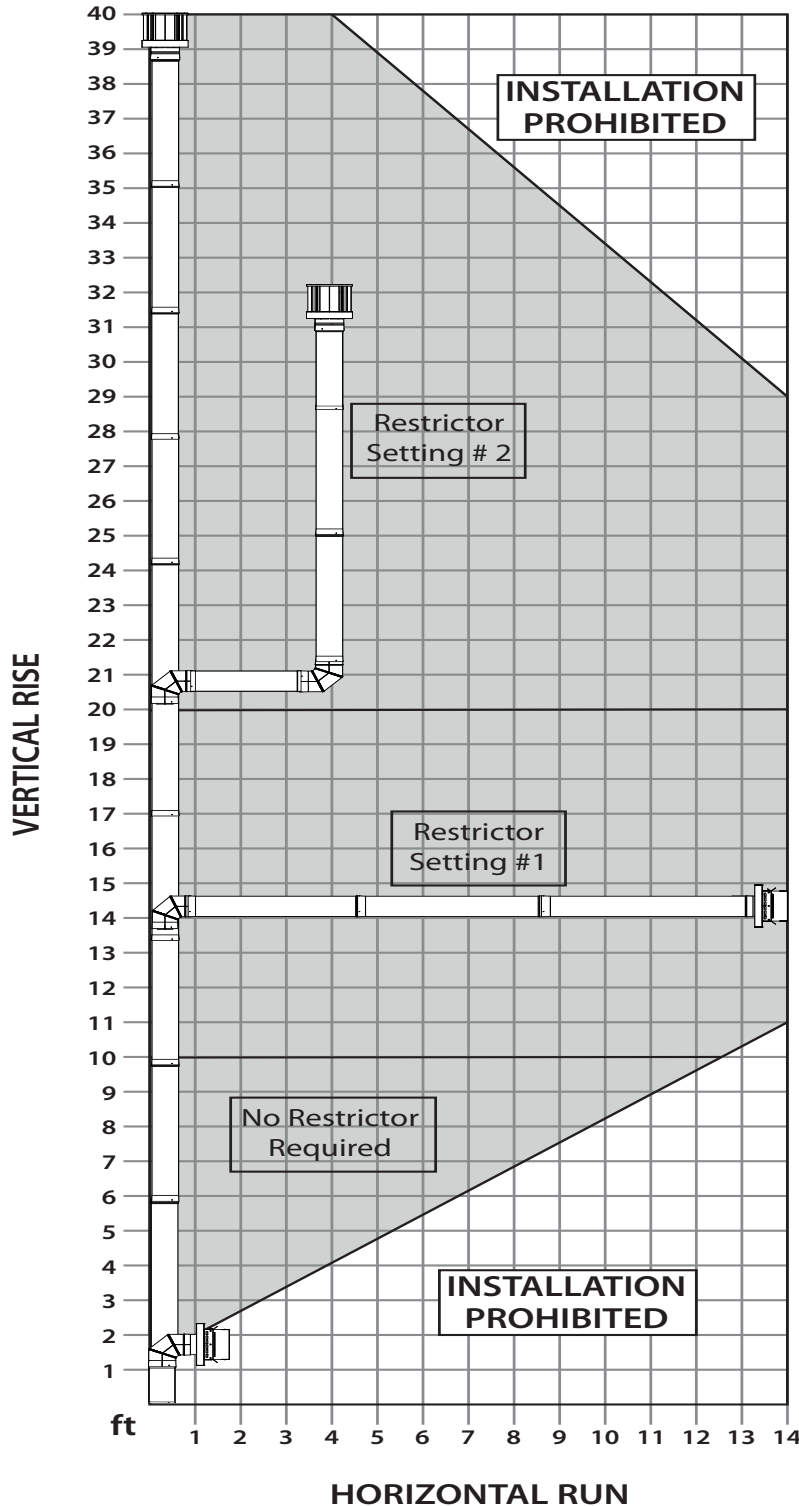

Figure 34: Possible Vent Configurations for Vertical and Horizontal Terminations.

# INITIAL INSTALLATION

## QUALIFIED INSTALLERS ONLY

### AIR RESTRICTOR:

When installing the Berkeley with 10ft (3.05m) or more of vertical venting it may be necessary to restrict the fresh air supply in the firebox to control the combustion and flame appearance. To install the air restrictor supplied with the unit the cabinet front and glass door must remove as outlined on page 12 in the MAINTENANCE AND SERVICE section. The firebox baffle must be removed next by removing the two front screws using a T20 screwdriver (Figure 35). Next, remove the restrictor set screws and install the restrictor at the desired setting (refer to Figure 36) and tighten the set screws to hold it in place. Refer to Figure 34 on the previous page for the correct restrictor setting to use in accordance with your installation. Re-install the baffle, glass door, and cabinet front before operating the Berkeley.

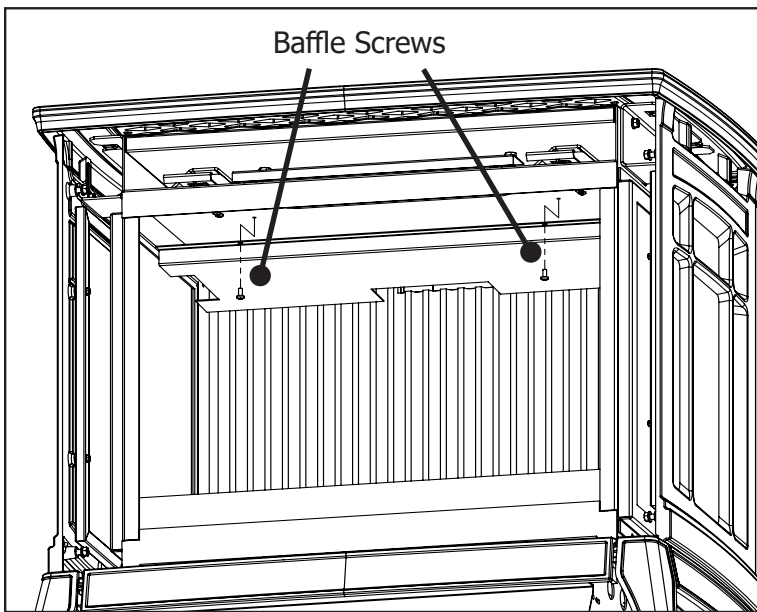

Figure 35: Baffle Removal

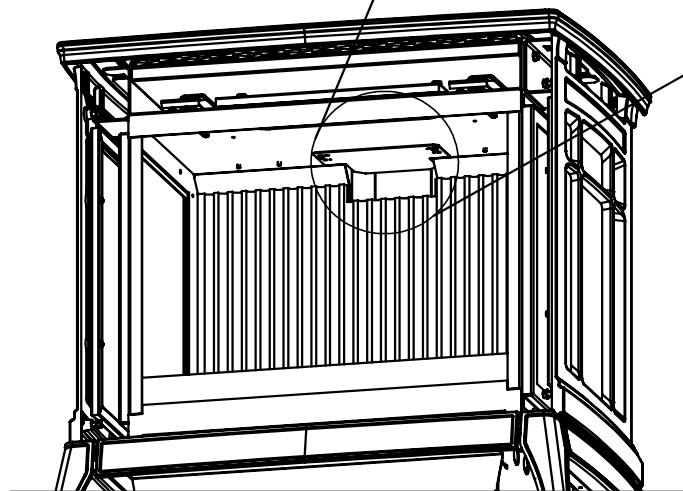
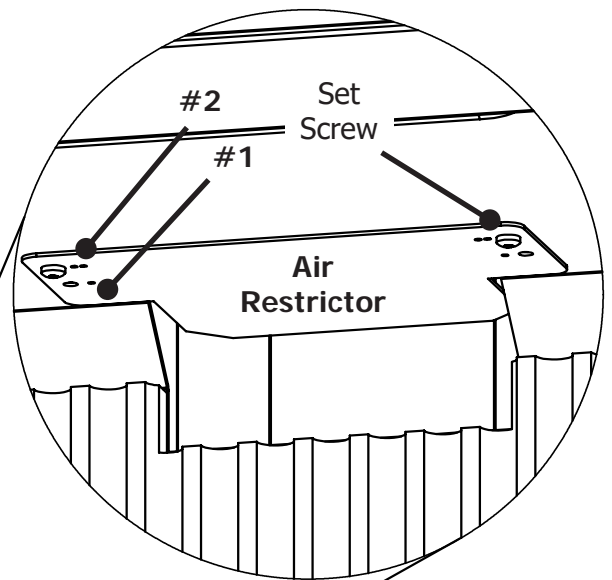

Figure 36: Installation of Air Restrictor



# INITIAL INSTALLATION

## QUALIFIED INSTALLERS ONLY

### HORIZONTAL TERMINATION:

#### NOTES:

**1. Horizontal pipes must not be level. For every 12 inches (305 mm) of horizontal travel (away from the stove), there should be at least ¼ inch (6.4 mm) of vertical travel. Never allow the vent to run downward, as this could cause high temperatures or even present the possibility of a fire.**

2. The exterior of the horizontal vent termination must not be blocked or obstructed.

3. If the vent termination is not being attached to wood, the four wood screws provided should be replaced with material appropriate fasteners.

4. For buildings with vinyl siding, a vinyl standoff should be installed between the vent cap and the exterior wall. Attach the vinyl siding standoff to the horizontal termination. Note that the termination bolts onto the flat portion of the standoff, providing an air space between the wall and the vent termination. The air gap prevents excessive heat from possibly melting the vinyl siding.

5. Horizontal pipes must be supported every 3 feet (914 mm). Plumber's all round strap will suffice.

6. When running horizontal pipe, clearances to combustibles must be maintained 1½ inches (38 mm) sides, 1½ inches (38 mm) bottom, and 2 inches (51 mm) top.

**Step 1.** Set the fireplace in the desired location. Check to determine if wall studs will be in the way when the venting system is attached. If this is the case, the location of the fireplace may have to be adjusted or the venting may have to be offset.

**Step 2.** Direct vent pipe sections are designed with special twist-lock connections. Dry fit the desired combination of pipe and elbows to the appliance adaptor.

**Step 3.** With the pipe in the correct position and attached to the fireplace, mark the wall for a 10 inches (25.4 cm) x 10 inches (25.4 cm) square hole (see Figure 31). The center of the hole should match the center line of the horizontal pipe. Cut and frame the hole in the exterior wall where the vent will be terminated. If the wall being penetrated is made of a non-combustible material (i.e. masonry or concrete) a 7 inches (17.8 cm) hole is acceptable.

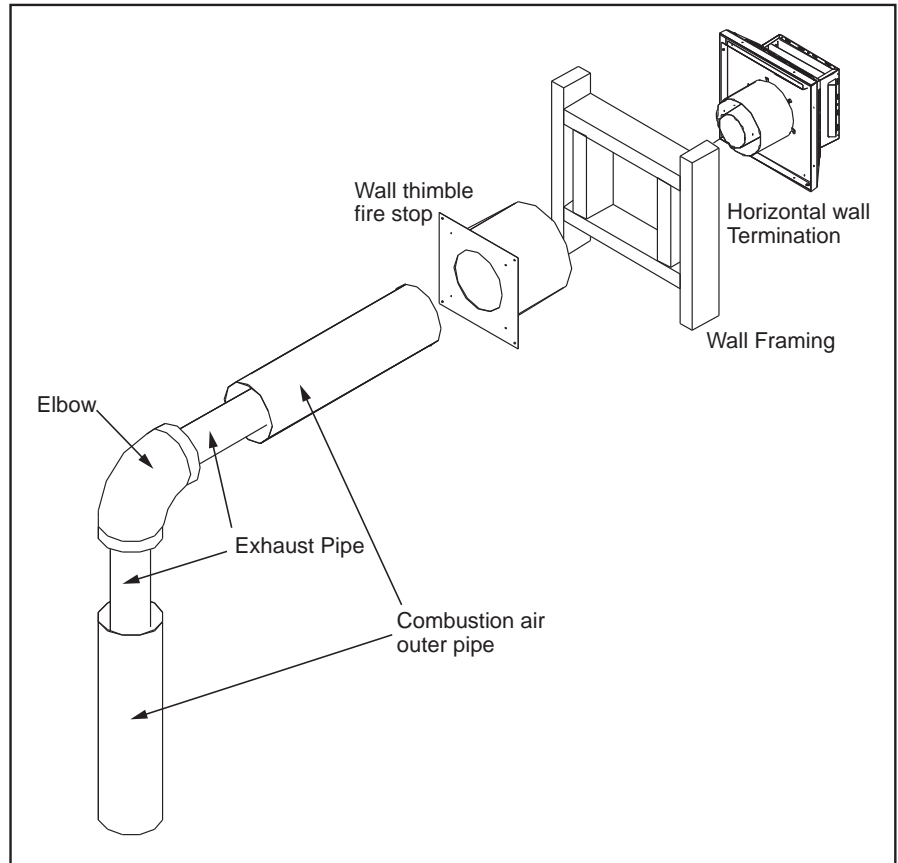

**Figure 37. Horizontal Vent Termination**

# INITIAL INSTALLATION

## QUALIFIED INSTALLERS ONLY

- Step 4.** With the hole now framed, the wall thimble installed, and the pipe extending into the wall, proceed to the outside. Attach the termination to the pipe using RTV and Mil-Pac or Rutland No 78 Stove and Gasket Cement to seal joints. The vent pipe must extend into the vent cap at least 1¼ inches (3.2 cm). Secure the connection between the vent cap and the pipe by attaching the two (2) sheet metal straps, which extend from the vent cap assembly to the outer wall of the vent pipe. Bend any remaining portion of the strap back towards the vent cap. Security Secure Vent uses a twist lock cap.
- Step 5.** Position the horizontal vent termination in the center of the 10 inches (25.4 cm) square hole and attach to the exterior wall with the four screws provided. The arrow on the vent termination should be pointing up. Run a bead of non-hardening mastic around the edges of the vent cap, to make a seal with the wall. Ensure the proper clearances to combustibles have been maintained.

### VERTICAL TERMINATION:

- Step 1.** Check the instructions for required clearances (air spaces) to combustibles when passing through ceilings, walls, roofs, enclosures, attic rafters, or other nearby combustible surfaces. Do not pack air spaces with insulation.
- Step 2.** Set the gas appliance in the desired location. Drop a plumb bob down from the ceiling to the position of the appliance flue exit, and mark the location where the vent will penetrate the ceiling. Drill a small hole at this point. Next, drop a plumb bob from the roof to the hole previously drilled in the ceiling, mark the spot where the vent will penetrate the roof. Determine if ceiling joists, roof rafters, or other framing will obstruct the venting system. You may wish to relocate the appliance, or to offset, to avoid cutting load bearing members.
- Step 3.** To install the Round Support Box/Wall Thimble in a flat ceiling, cut a 10 inch (25.4 cm) square hole in the ceiling, centered in the hole drilled in Step 2. Frame the hole as shown in Figure 31.

- Step 4.** Assemble the desired lengths of black pipe and elbows necessary to reach from the appliance adapter up through the Round Support Box. Insure that all pipe and elbow connections are in their fully twist-locked position.

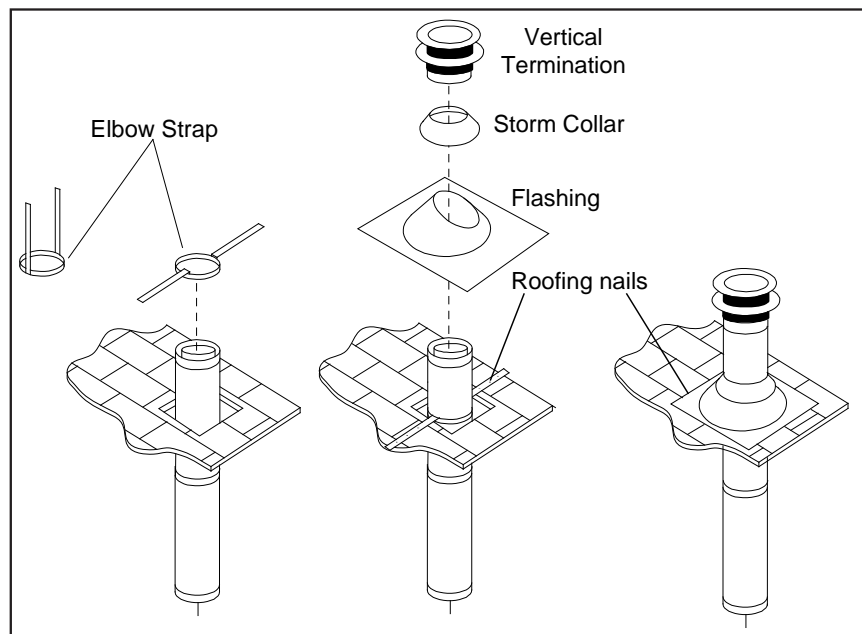
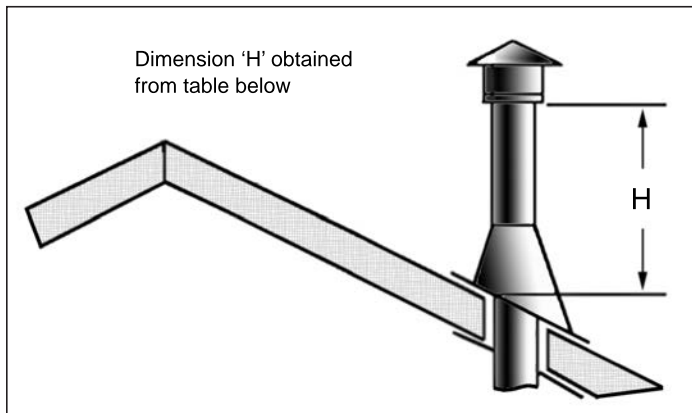

Figure 38. Vertical Vent Termination

# INITIAL INSTALLATION

## QUALIFIED INSTALLERS ONLY

- STEP 5.** Cut hole in the roof centered on the small hole placed in the roof from Step 2. The hole should be of sufficient size to meet minimum requirements for Clearance to Combustibles, as specified. Continue to assemble lengths of pipe and elbows necessary to reach from the ceiling support box up through the roof line. Galvanized pipe and elbows may be utilized in the attic, as well as above the roof line. The galvanized finish is desirable above the roof line, due to the higher corrosion resistance.
- STEP 6.** Once the pipe sections have been joined, and run up through the hole in the roof, slip an elbow strap over the exposed sections, bend the support straps outwards, and push the elbow strap down to the roof level, as shown in Figure 38. Tighten the clamp around the pipe section. Use a level to make sure the pipe is truly vertical. With roofing nails, secure the support straps to the roof. Seal the nails holes heads with non-hardening mastic. Trim the excess length of the support straps that extend out beyond the edge of the flashing.
- STEP 7.** Slip the flashing over the pipe section protruding through the roof. Secure the base of the flashing to the roof with roofing nails. Use a non-hardening sealant between the uphill edge of the flashing and the roof. Insure the roofing material overlaps the top edge of the flashing. Verify that you have at least the minimum clearance to combustibles at the roof line.
- STEP 8.** Continue to add pipe sections until the height of the vent cap meets the minimum code requirements. Refer to Figure 39 and Table 7. Note that for steep roof pitches, the vent height must be increased. In high wind conditions, nearby trees, adjoining roof lines, steep pitched roofs, and other similar factors can result in poor draft, or down drafting. In these cases, increasing the vent height may solve the problem.
- STEP 9.** Slip the storm collar over the pipe, and push it down to the top of the roof flashing as shown in Figure 38. Use the non-hardening sealant around the joint between the pipe and the storm collar.
- STEP 10.** Twist-lock the vent cap.



**Figure 39: Height of Vertical Termination; Reference Table 7.**

**Table 7: Minimum 'H' for Figure 39.**

Roof Pitch	Minimum Height (H)	
	Feet	Meters
Flat to 7/12	1	0.3
Over 7/12 to 8/12	1.5	0.46
Over 8/12 to 9/12	2	0.61
Over 9/12 to 10/12	2.5	0.76
Over 10/12 to 11/12	3.25	0.99
Over 11/12 to 12/12	4	1.22
Over 12/12 to 14/12	5	1.52
Over 14/12 to 16/12	6	1.83
Over 16/12 to 18/12	7	2.13
Over 18/12 to 20/12	7.5	2.29
Over 20/12 to 21/12	8	2.44

# INITIAL INSTALLATION

## QUALIFIED INSTALLERS ONLY

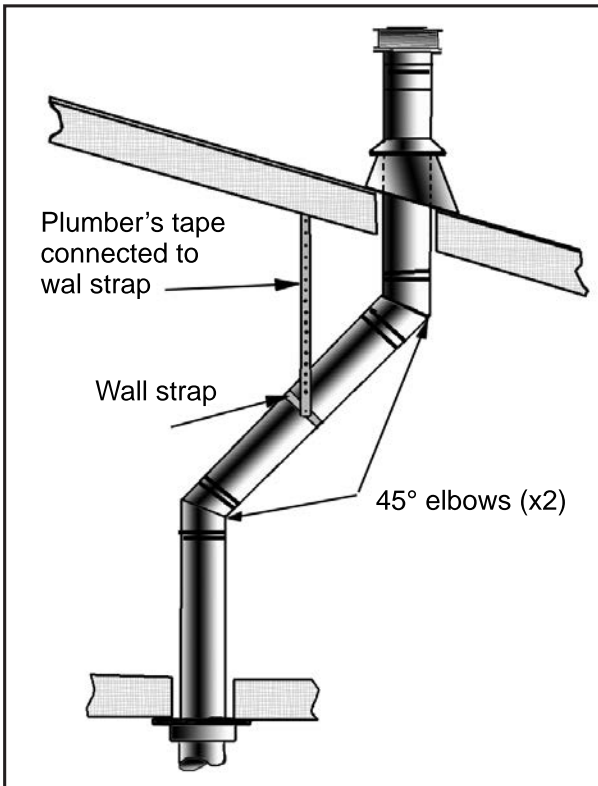
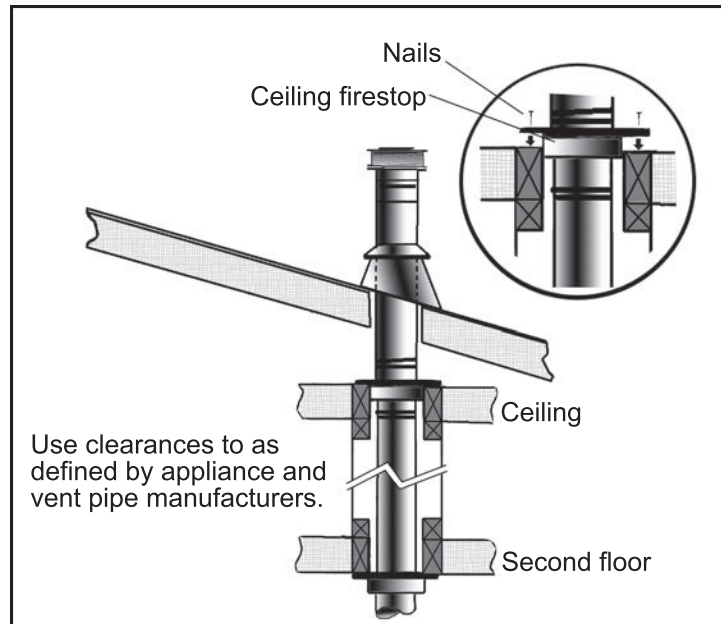

**Figure 40: Use of Wall Straps.**

closets and storage spaces, which the vertical vent passes through, must be enclosed. The enclosure may be framed and sheet-rocked with standard building materials. However consult the appliance manufactures installation instructions for the minimum allowable clearance between the outside of the vent pipe, and the combustible surfaces of the enclosure. Do not fill any required air spaces with insulation.

### NOTES:

- (1) If an offset is necessary in the attic to avoid obstructions, it is important to support the vent pipe every 3 feet (914 mm), to avoid excessive stress on the elbows, and possible separation. Wall straps are available for this purpose (see Figure 40).
- (2) When ever possible, use 45° degree elbows instead of 90° degree elbows. The 45° degree elbow offers less restriction to the flow of flue gases and intake air.
- (3) For multi story installations; a ceiling firestop is required at the second floor, and any subsequent floors (see Figure 41). The opening should be framed to 10" (254 mm) x 10" (254 mm) inside dimensions, in the same manner as shown in Figure 21.
- (4) Any occupied areas above the first floor, including



**Figure 41: Multi-Story Vent Pipe Installation.**

# INITIAL INSTALLATION

## QUALIFIED INSTALLERS ONLY

### GAS LINE CONNECTION AND TESTING:

**WARNING:** Only persons licensed to work with gas piping may make the necessary gas connections to this appliance.

#### GAS LINE CONNECTION

- This stove is equipped with a certified flexible pipe located on the left side of the unit terminating in a 3/8" female NPT fitting. Consult your local authorities codes or the CAN/CGA B 149 (1 or 2) installation code in Canada, or in the USA gas installations follow either local codes or the current edition of the National Fuel Gas Code ANSI Z223.1.
- The efficiency rating of this appliance is a product thermal efficiency rating determined under continuous operating conditions and was determined independently of any installed system.

The appliance and its shutoff valves must be disconnected from the gas supply piping system during any pressure testing where the pressure exceeds 1/2 PSIG (3.45 KPa) or damage will occur to the valve.

The appliance must be isolated from the gas supply piping system by closing its individual manual shutoff valve during any pressure testing of the gas supply piping system at test pressures equal to or less than 1/2 psig (3.45 KPa).

**Always check for gas leaks with a soap and water solution after completing the required pressure test.**

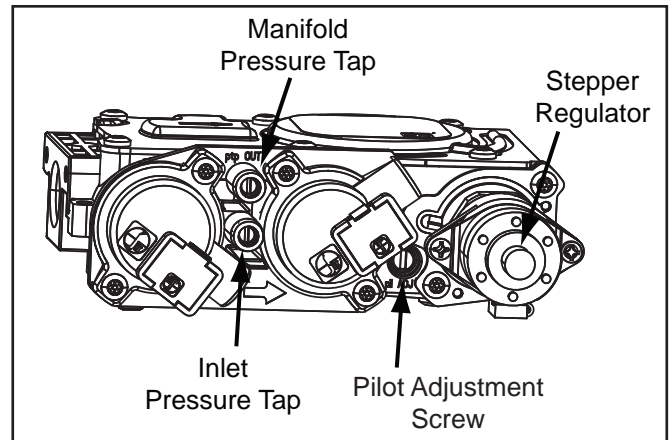

**Figure 42: Fully Labeled Gas Valve.**  
See Dexen User Manual for Berkeley-D valve details

#### TO TEST VALVE PRESSURES

The pressure taps are located on the top right of the valve shown in Figure 42.

- Turn set screw 1 turn counter clockwise to loosen,
- Place 5/16" (8 mm) I.D. hose over pressure tap system.
- Check pressures using a manometer.
- When finished, release pressure, remove hose & tighten set screw.

**Table 8: Pressure and BTU Information.**

Model		Natural Gas	Propane
Common	<b>Main Orifice</b>	#44 Left, #45 Right	#55 mm Left & Right
Common	<b>Manifold Pressure</b>	3.6" W.C. (0.89 KPa)	10.0" W.C. (2.49 KPa)
Common	<b>Min. Manifold Pressure</b>	1.6" W.C. (0.40 KPa)	6.4" W.C. (1.59 KPa)
Common	<b>Max Supply Pressure</b>	7.0" W.C. (1.74 KPa)	11.0" W.C. (2.74 KPa)
Common	<b>Min. Supply Pressure</b>	4.5" W.C. (1.12 KPa)	10.4" W.C. (2.59 KPa)
Common	<b>Max BTU/hr Input</b>	40,000 BTU/hr (11.7 KW)	39,000 BTU/hr (11.4 KW)
Berkeley-IPI	<b>Min. BTU/hr Input</b>	13,000 BTU/hr (3.81 KW)	16,000 BTU/hr (4.69 KW)
Berkeley-D	<b>Min. BTU/hr Input</b>	27,000 BTU/hr (7.91 KW)	30,000 BTU/hr (8.79 KW)

**NEVER USE AN OPEN FLAME FOR LEAK TESTING.**

# INITIAL INSTALLATION

## QUALIFIED INSTALLERS ONLY

### ELECTRICAL REQUIREMENTS:

The fireplace must be electrically connected and grounded in accordance with local codes or, in the absence of local codes, with the current CSA C22.1 Canadian Electrical Code Part 1, Safety Standards For Electrical Installations, or The National Electrical Code ANSI / NFPA 70 in the US.

**WARNING:** The electrical grounding instructions must be followed. The fan kit is equipped with a three-prong (grounding) plug for your protection against shock hazard, and should be plugged directly into a properly grounded three-prong outlet. DO NOT cut or remove the grounding prong from this plug.

**CAUTION:** When servicing controls, label all wires prior to disconnection. Wiring errors can cause improper and dangerous operation. Verify proper operation after servicing.

If any of the original wire as supplied with the appliance must be replaced, it must be replaced with 18 AWG wire with a temperature rating of 105°C

**Note: For Berkeley-D specific wiring diagram refer to the Dexen user manual supplied and label attached to the fireplace.**

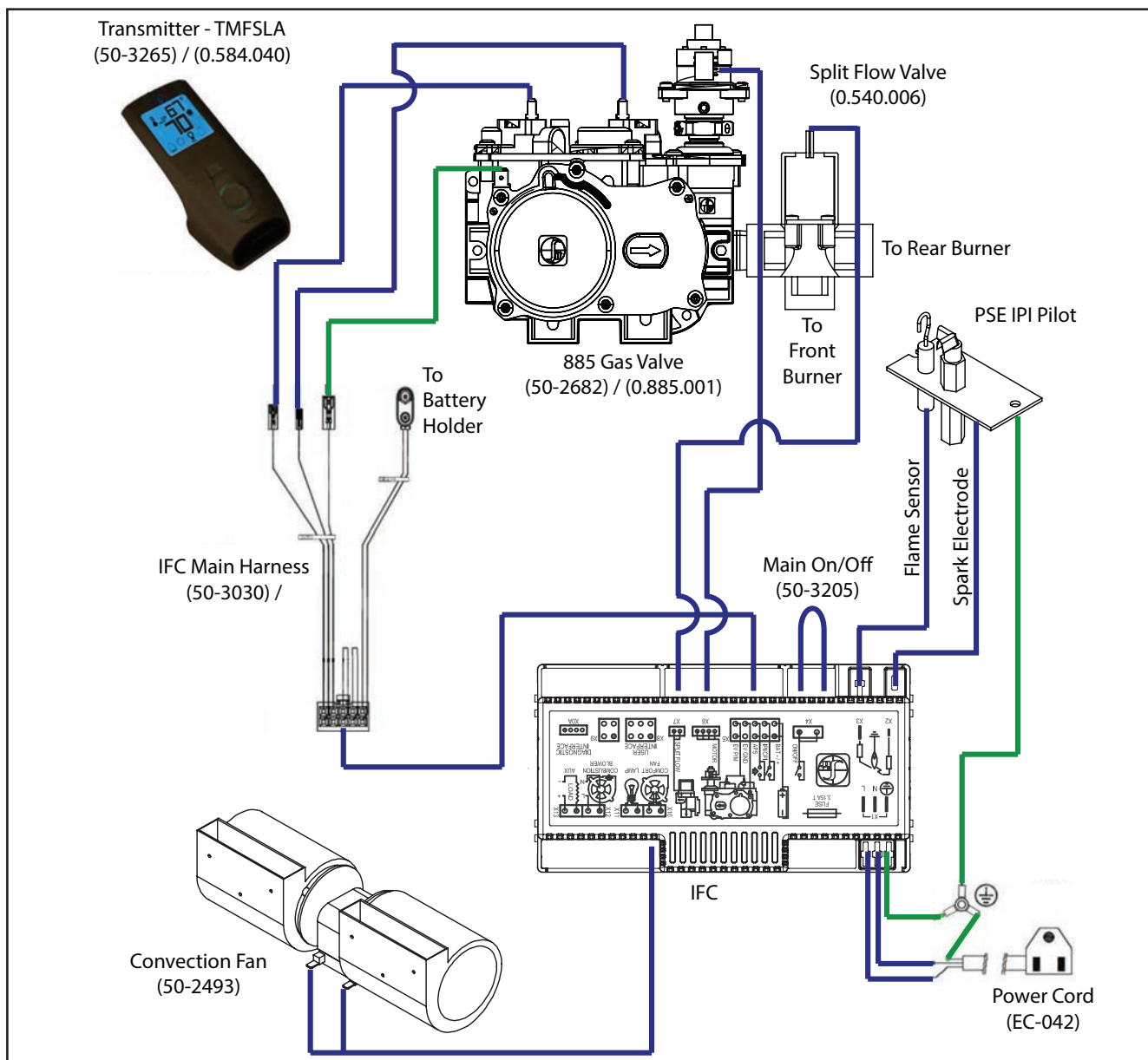

Figure 43: Proflame 2 wiring diagram.



# SECONDARY INSTALLATION

## LOG SET INSTALLATION:

The placement of the logs is not arbitrary. If they are positioned incorrectly, the flames can be “pinched” and will not burn correctly. All of the logs come with either a notch or ledge, which make alignment easier. Using the pictures provided, carefully set the logs in place (see Figures 44 through 50).

**NOTE: The logs are fragile and should be handled gently.**



Figure 44. Ember Bed Assembly.

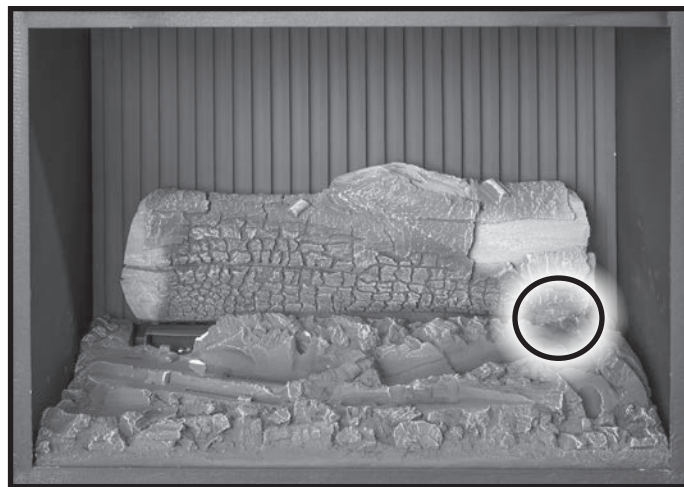

Figure 45. Back Log.

4. Next, Install the two large flat bottommed logs in the middle of the ember bed as shown in Figure 46.

Please ensure that there is no damage to the ember bed or any log prior to installation.

To Install Log Set:

1. Remove the top and front of the unit. Then remove the glass door by releasing the top spring latches.

2. Next, install the ember bed assembly, as shown in Figure 44, by holding onto the slots in the ember bed. The ember bed must be held at a 45° angle, from left to right, in order for it to fit inside the firebox. When installed correctly it should butt against the back of the firebox.

3. Install the back log, as shown above in Figure 45, by sitting it on top of the ember bed at the back of the firebox. There is a locating half round on the right side, highlighted above, to aid in correct placement

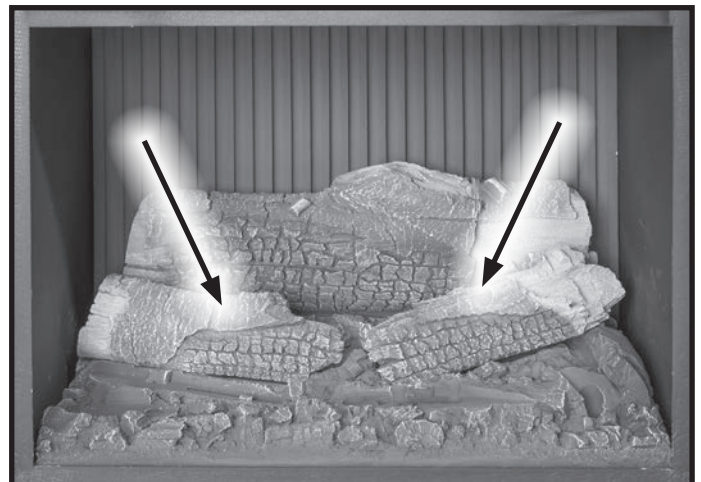
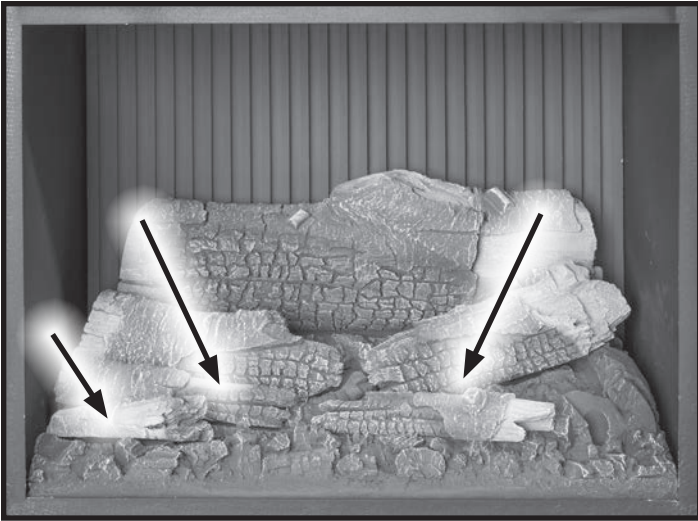

Figure 46. Rear Ember Bed Logs.

## SECONDARY INSTALLATION



**Figure 47. Front Ember Bed Logs.**

5. Install the front three ember bed logs as shown in Figure 47. Note the locating notches on the backside of the logs. The depressions in the ember bed only allow the logs to be installed one way.

6. Next, Install the left and right top logs, as shown in Figure 48. Note the locating notches on the bottom side of both logs (areas highlighted).



**Figure 48. Top Logs.**

7. Install the last log on top, on the right side, as shown in Figure 49. Note the locating notch on the bottom side that matches the half round on top of the large bottom log sitting on the ember bed.

**NOTE:** While the glass is still removed, it is recommended that the gas line be purged by lighting the pilot.

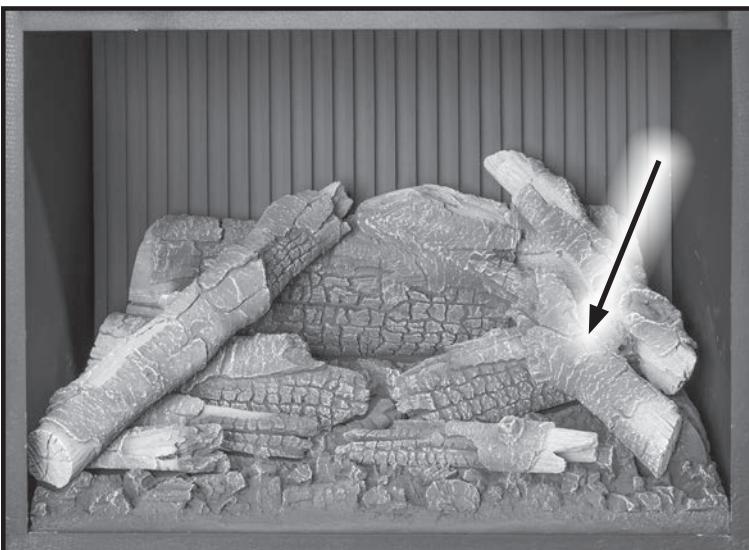

**Figure 49. Final Top Log.**

## SECONDARY INSTALLATION

---



**Figure 50. Proper Burn and Flame**

8. Re-install the firebox door, then the cabinet front and top.
9. Run the unit for 15 minutes then adjust both venturis as needed. Figure 50 above depicts what the burn and flame appearance should look like when the log set is properly installed and venturis adjusted.

When re-lighting the fireplace for the first time since the log set has been installed/replaced, watch for ignition at ALL the burner ports. If a long delay is noticed, turn the appliance off and wait for it to cool down. Then remove the glass and make sure none of the burner ports are blocked.

**Maintenance:** Once a year, the logs should be removed and checked for deterioration or large amounts of soot. A small amount on the bottom side of the logs is normal. Remove and replace the logs in the same manner described above.

If new logs are required, contact your nearest ENVIRO dealer.

**Never operate the fireplace with the glass door removed.**



# SECONDARY INSTALLATION

## SAFETY SCREEN REPLACEMENT:

The Berkeley is supplied with safety screens already installed on the back of the cast front and sides. If a safety screen becomes damaged must it be replaced with either part number 50-3243 (front) or 50-3244 (side) by following the steps below:

Front Screen

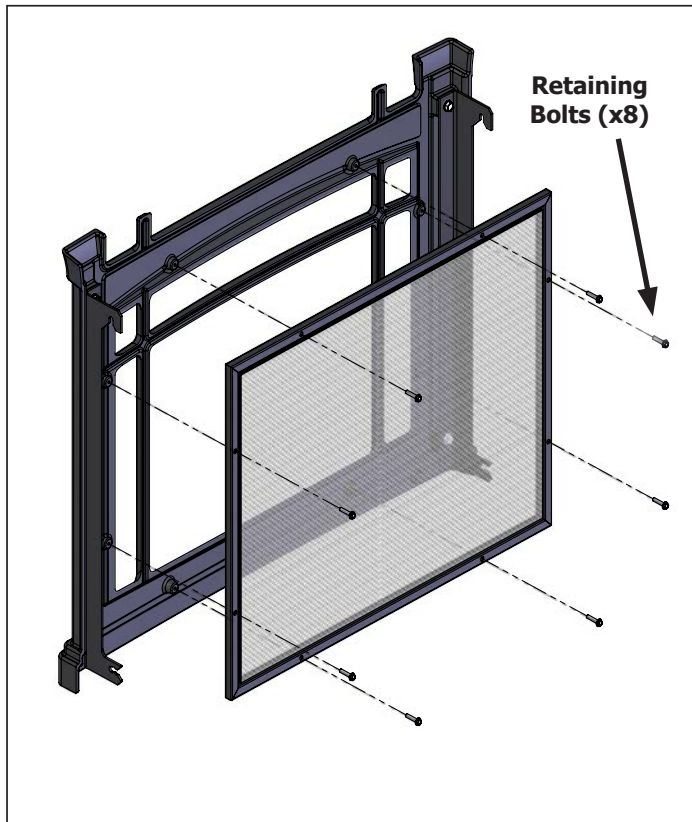

Figure 51. Safety Screen Removal - Front

Side Screen

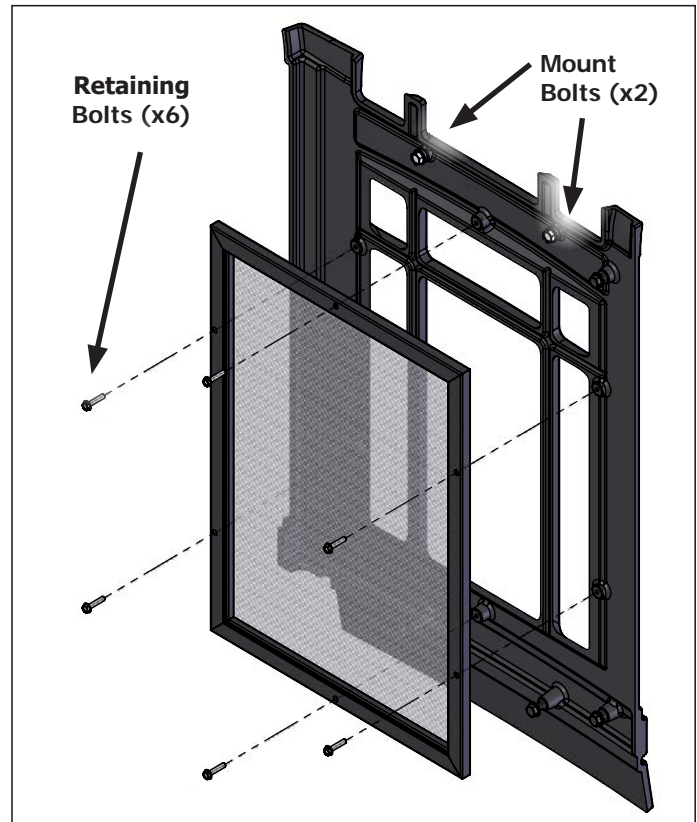

Figure 52. Safety Screen Removal - Side

**Step 1:** Turn off the Berkeley and allow it to fully cool down.

**Step 2:** Remove the cast top by simply lifting up and lay it down on a blanket or other soft surface to prevent from scratching the finish.

**Step 3:** Remove the cast door as directed in MAINTENANCE AND SERVICE - CAST DOOR REMOVAL.

**Step 4:** If replacing the side screen skip to step 5. If replacing the front screen remove the eight (8) retaining bolts (Figure 51) using a 1/4" socket and remove the damaged screen while noting the orientation. Install the new screen (50-3243) by simply re-installing the retaining bolts. Re-install the cast door and top to finish.

**Step 5:** Remove the cast side (left or right) by loosening the two (2) top mount bolts (Figure 47) using a 3/8" wrench. Next, lift up to remove the cast side and lay it down on a soft surface.

**Step 6:** Remove the six (6) retaining bolts (Figure 52) using a 1/4" socket and remove the damaged screen while noting the orientation. Install the new screen (50-2344) by simply re-installing the retaining bolts.

**Step 7:** Re-install the cast side and tighten the two (2) top mount bolts. Re-install the cast door and top to finish.

# TROUBLE SHOOTING

## DIAGNOSTIC FLASH CODES (DOES NOT APPLY TO BERKELEY-D MODELS):

1. Fail to ignite: If there is no positive ignition, the board will go into lock out and the LED will blink 3 times in intervals until the system is reset.
2. Low battery condition (<4V): the LED indicator will blink one (1) time in intervals.
3. Parasitic Pilot Flame: the LED indicator will blink two (2) times in intervals.
4. System Lock out: the LED indicator will blink three (3) times in intervals.

### Additional Ignition Information

1. The Proflame 2 IFC will only attempt ignition once.
2. The ignition attempt will last approximately 60 seconds.
3. If no ignition is sensed after 60 seconds the IFC will lockout (see above)

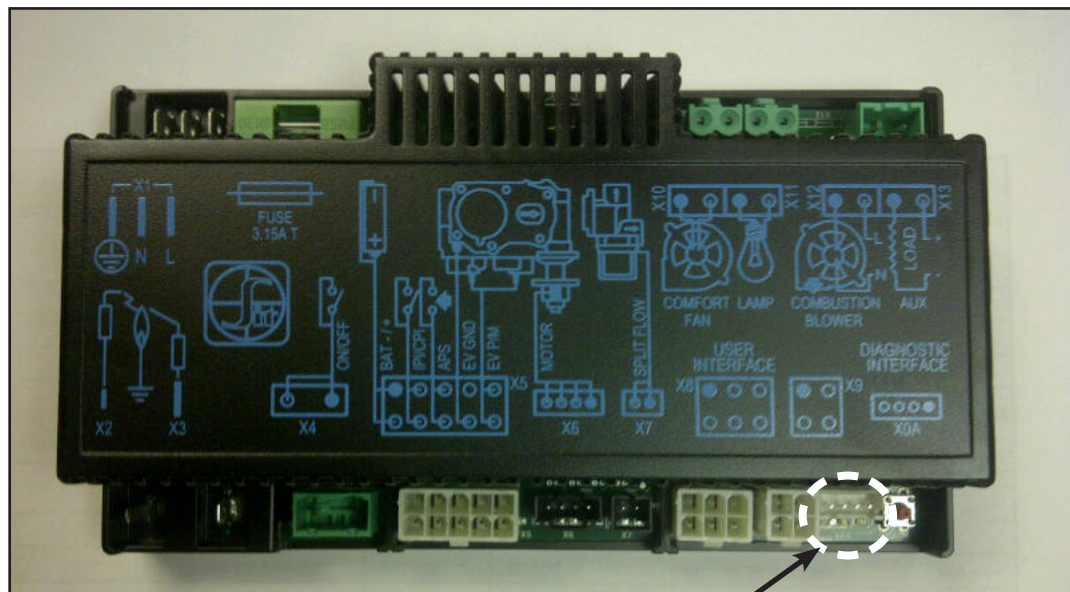

LED Location

Figure 53: IFC LED Location

# TROUBLE SHOOTING

**Note: For Berkeley-D specific troubleshooting refer to the Dexen user manual supplied**

Problem	Possible Cause	Solution
Thermostat does not work	The pilot flame has gone out	· Turn it ON
	The On/Off switch is turn to OFF	
	The thermostat is set too high	· Set the thermostat to a lower temperature
No spark generation	Spark develops near the pilot assembly or could occur onboard	· Check pilot assembly wiring
		· Check for broken or poor connection from the sparker to the electrode
		· Check for the spark shorting or arcing at other locations
		· Check for defective sparker and spark electrode
No pilot flame ignition	No spark from the igniter	· See "no spark generation"
	Air in the gas line	· It takes a while for all the air to purge out of the pilot before gas can reach the pilot and ignite
	Pilot gas pressure dropout upon main burner gas valve opening	· Check gas mains supply and pressure
	No gas flow out of the pilot burner	· Check gas valve wirings and connections to the IFC
		· Check the pilot burner for obstruction
		· Check the wirings and connections between the pilot assembly and the IFC
Pilot will not remain lit	Problem with Flame Sensor circuit	· Check for proper connection of the Flame Sensor to the IFC board
		· Check pilot for full flame impingement around Flame Sensor
		· If flame is too small, check gas pressure, adjust pilot rate screw, check pilot head for damage
		· Ensure the ground wire is properly attached to the pilot mounting bracket and that it makes a good electrical connection.
	Restrictor setting	· Use the correct restrictor setting for the venting configuration
Remote control does not work	The pilot light has gone out	· See "Pilot will not remain lit"
	The remote is too far away from the heater	· Use the remote closer to the heater
	One of the three remote control batteries are dead	· Replace the batteries
No reaction to command	Transmitter batteries are low	· Replace the batteries
	A maximum number of failed ignitions or flame restorations have been reached.	· Remove any possible blocking conditions. See "locking conditions"
		· See how to reset the board from Lockout
No communication between the remote control and the IFC	No communication between the remote control and the IFC	· Reprogram the transmitter to the IFC
		· Follow the initializing system for the first time

# TROUBLE SHOOTING

---

Problem	Possible Cause	Solution
Locking conditions	Reset the Proflame IFC	· Turn the system off by pressing the ON/OFF button on the transmitter
		· After approximately 2 seconds press the ON/OFF button on the transmitter again.
		· In the manual flame control mode, use the down arrow button to reduce the flame to off, indicated by the word OFF displayed on the transmitter LCD screen.
		· Wait approximately 2 seconds and press the up arrow button, the ignition sequence will start.
		· With the transmitter off, disconnect main power from stove for a few seconds then re-connect power.
		· Wait approximately 2 seconds and press the Reset button on the IFC
Main burners will not start	The pilot flame has gone out	· See "Pilot will not remain lit"
	The remote control is not working correctly	· Replace the batteries
	The thermostat is disconnected or set too high	· Set the thermostat to a lower temperature
	Reset the Proflame IFC	· See "Locking Conditions"
Flame lifting	Leak in vent pipe	· Check for leaks in vent connections
	Improper vent configuration	· Check vent configuration with manual
	Terminal may be re-circulating flue gases	· Check to see if terminal is on correctly
		· May need to install high wind termination cap. · Contact dealer
Blue Flames	The heater has just been started	· Normal during start up: flame will yellow as the fireplace heats up
	Improper air shutter adjustment	· Adjust air shutter – contact your dealer
Glass fogs up	Normal condition: after the appliance warms up the glass will be clear.	**Due to additives in gas, glass may get hazy during operation** Clean as needed.
Flames are burning "dirty" or sooting	The logs or are placed incorrectly	· Check log positioning
	Improper air shutter adjustment	· Increase primary air by opening the air shutter and/or by opening the vent restrictor
		· Check for proper venting and blockage of the vent termination
		· See also "Burners will not remain lit"
Incorrect rating input	· Check manifold pressure and clock input rating for over-firing	



# PARTS LIST

**Note: For Berkeley-D specific replacement parts refer to the Dexen user manual supplied**

Reference Number	Part Description	Part Number
1	Door Latch Mechanism w/ Spring (set of 2)	50-1285
2	Firebox Air Restrictor	50-3231
3	Pilot Shield	50-3232
4	Convection Fan only	50-2493
-	Convections Fan w/ Mount	50-3836
5	Battery Holder 4 x AA	50-3027
6	Proflame 2 IFC	50-3791
-	Proflame 2 IFC Wire Harness (0.584.924)	50-3030
-	IFC ON/OFF Jumper	50-3205
7	Proflame 2 Transmitter (TMFSLA)	50-3265
8	PSE IPI Pilot Assembly (2021)	50-4058
-	IPI LP Pilot Orifice (2021)	50-4080
9	S.I.T. 885 Valve w/ NG Stepper Motor	50-2682
10	Heyco Strain Relief	EC-044
11	Domestic Power Cord (115v)	EC-042
12	Log Set (9 pieces)	50-3234
13	Ceramic Burner Assembly	50-3233
14	Front Door Glass w/ Gasket (16.875 x 21.0625in)	50-3235
15	Front Door Complete	50-3236
16	Side Door Glass w/ Gasket (15.875 x 11.625in)	50-3237
17	Side Door Complete	50-3238
18	Ceramic Fluted Liner (1 piece)	50-3239
19	Replacement Safety Screen - Front	50-3243
20	Replacement Safety Screen - Side	50-3244
21	Vent Collar Cover	50-3245
22	Termination Guard	50-3266
23	Berkeley-IPI Owners Manual	50-3260
-	Conversion Kit - NG to LP (Stepper Motor Only)	50-3753
-	12 oz. Can of Matallic Black Touch Up Paint	PAINT-12-MB

# PARTS LIST

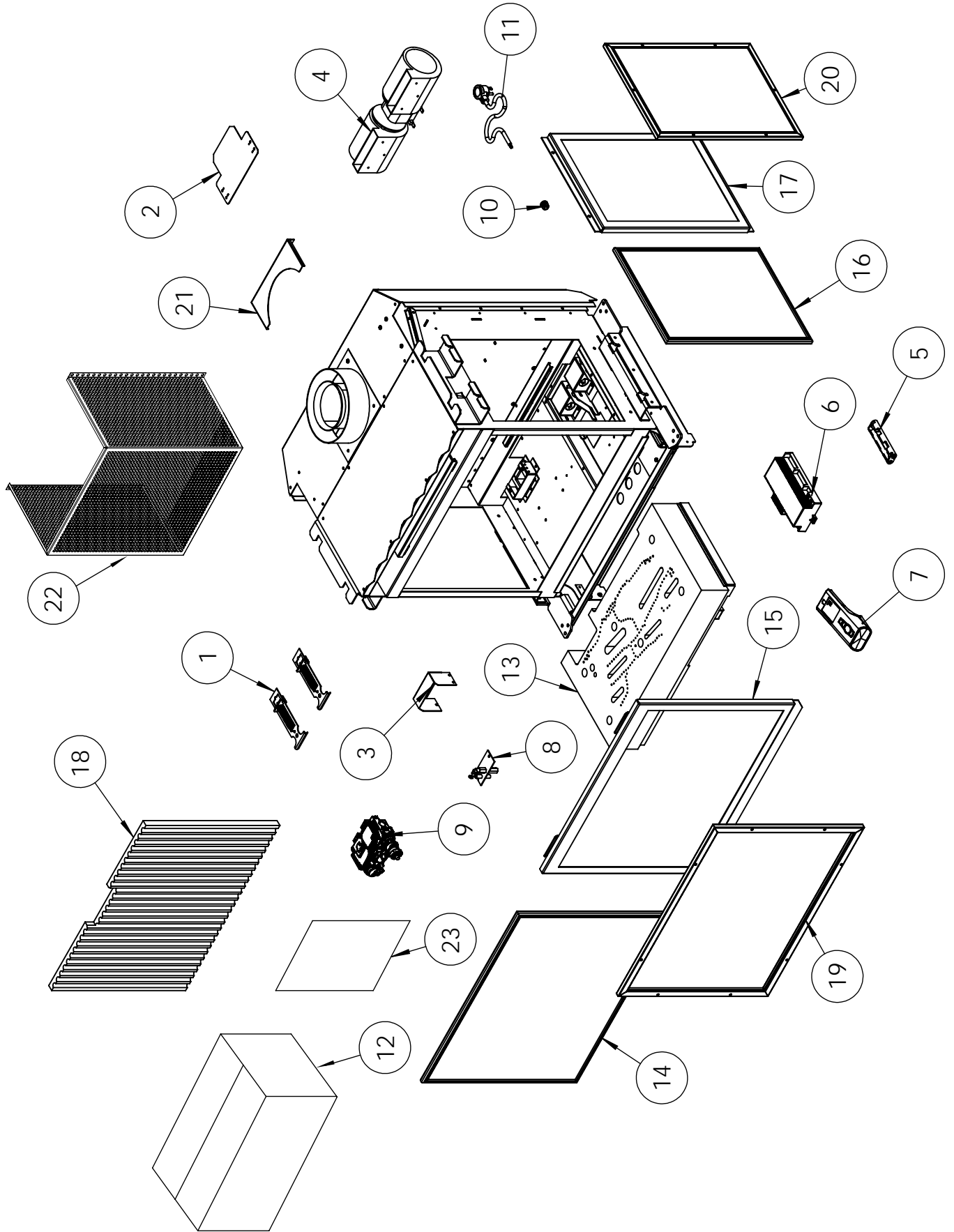

# PARTS LIST

Reference Number	Part Description	Part Number
24	Cast Top - Painted	50-3246
-	Cast Top - Enameled Antique Chestnut	50-3247
25	Cast Front - Painted	50-3248
-	Cast Front - Enameled Antique Chestnut	50-3249
26	Cast Skirt - Painted	50-3250
-	Cast Skirt - Enameled Antique Chestnut	50-3251
27	Cast Right Side - Painted	50-3252
-	Cast Right Side - Enameled Antique Chestnut	50-3253
28	Cast Left Side - Painted	50-3254
-	Cast Left Side - Enameled Antique Chestnut	50-3255
29	Cast Leg - Painted (1 piece)	50-3256
-	Cast Leg - Enameled Antique Chestnut (1 piece)	50-3257

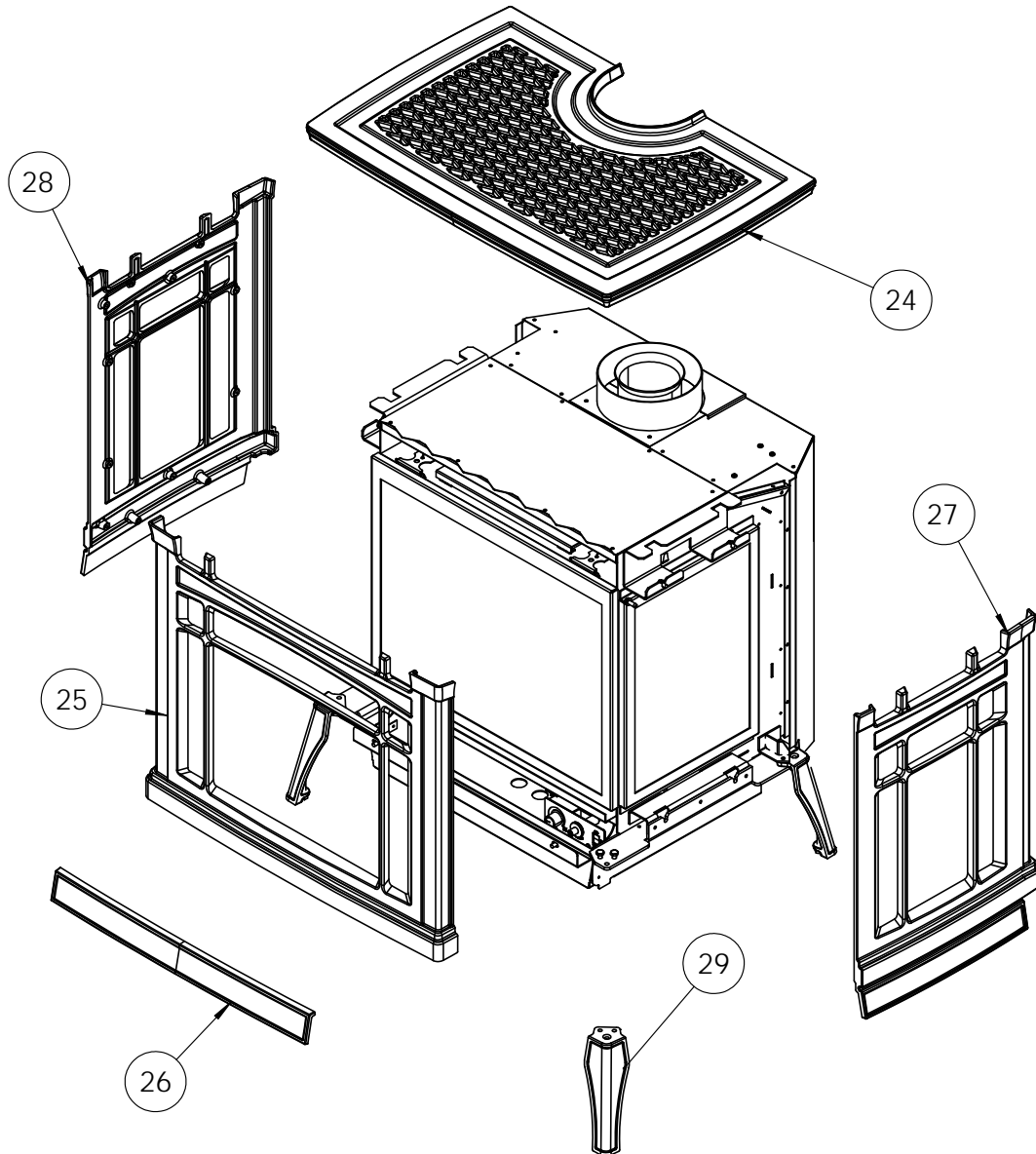



# Warranty for Enviro Gas Products

Sherwood Industries Ltd. ("Sherwood") hereby warrants, subject to the terms and conditions herein set forth, this product against defects in material and workmanship during the specified warranty period starting from the date of original purchase at retail. In the event of a defect of material or workmanship during the specified warranty period, Sherwood reserves the right to make repairs or to assess the replacement of a defective product at Sherwood's factory. The shipping costs are to be paid by the consumer. All warranties by Sherwood are set forth herein and no claim shall be made against Sherwood on any oral warranty or representation.

## Conditions

- A completed warranty registration must be submitted to Sherwood within 90 days of original purchase via the online warranty registration page or via the mail-in warranty registration card provided. Have the installer fill in the installation data sheet in the back of the manual for warranty and future reference.
- This warranty applies only to the original owner in the original location from date of install.
- The unit must have been properly installed by a qualified technician or installer, and must meet all local and national building code requirements.
- The warranty does not cover removal and re-installation costs.
- Sherwood Industries Ltd. reserves the right to make changes without notice.
- Sherwood Industries Ltd. and its employees or representatives will not assume any damages, either directly or indirectly caused by improper usage, operation, installation, servicing or maintenance of this appliance.
- A proof of original purchase must be provided by you or the dealer including serial number.
- This warranty does not cover any discoloration of the safety screen mesh.

## Exclusions

An expanded list of exclusions is available at [www.enviro.com/help/warranty.html](http://www.enviro.com/help/warranty.html)

This warranty does not cover:

- Damage as a result of improper usage or abuse.
- Damage caused from over-firing due to incorrect setup or tampering.
- Damage caused by incorrect installation.

## To the Dealer

- Provide name, address and telephone number of purchaser and date of purchase.
- Provide date of purchase. Name of installer and dealer. Serial number of the appliance. Nature of complaint, defects or malfunction, description and part # of any parts replaced.
- Pictures or return of damaged or defective product may be required.

## To the Distributor

- Sign and verify that work and information are correct.

### Sherwood Industries Ltd.

6782 Oldfield Road, Victoria, BC . Canada V8M 2A3  
 Online warranty registration: [www.enviro.com/warranty/](http://www.enviro.com/warranty/)

Category	One Year	Two Year	Limited Lifetime (7yr)
Parts <sup>1,2</sup> (unit serial number required)		✓	
Firebox Liner Panels <sup>3</sup>		✓	
Firebox			✓
Heat Exchanger			✓
Burner			✓
Ceramic Logs <sup>4</sup>			✓
Ceramic Glass <sup>5</sup>	✓		
Pedestal / Legs (excluding finish)			✓
Door Assembly			✓
Surround Panels (excluding finish)			✓
Exterior Panels (excluding finish)			Up to 5 years
Electrical Components		✓	
Exterior Surface Finishing	✓		
Labour	✓		

<sup>1</sup> Whereas warranty has expired, replacement parts will be warranted for 90 days from part purchase date. Labour not included. Unit serial number required.

<sup>2</sup> 50-173 Westport Fan Kit covered for up to 5 years from purchase date. Labour not included. Unit serial required.

<sup>3</sup> Excluding damage to the finish caused by improper setup of the appliance, or color changes.

<sup>4</sup> Log set and panels excludes wear and tear or breakage caused by cleaning or service.

<sup>4</sup> Glass is covered for thermal breakage. Photos of box, inside of door, and unit serial # must be supplied for breakage due to shipping.

<sup>6</sup> Exterior Surface finishing covers plating, enamel or paint and excludes colour changes, chipping, and fingerprints. Travel costs not included.

# INSTALLATION DATA SHEET

The following information must be recorded by the installer for warranty purposes and future reference.

NAME OF OWNER:  
\_\_\_\_\_  
  
ADDRESS:  
\_\_\_\_\_  
\_\_\_\_\_  
\_\_\_\_\_  
  
PHONE: \_\_\_\_\_

NAME OF DEALER:  
\_\_\_\_\_  
  
ADDRESS:  
\_\_\_\_\_  
\_\_\_\_\_  
\_\_\_\_\_  
  
PHONE: \_\_\_\_\_

MODEL: \_\_\_\_\_  
SERIAL NUMBER: \_\_\_\_\_  
DATE OF PURCHASE: \_\_\_\_\_ (dd/mm/yyyy)  
DATE OF INSTALLATION: \_\_\_\_\_ (dd/mm/yyyy)  
  
 NATURAL GAS (NAT)       PROPANE(LPG)  
  
INLET GAS PRESSURE: \_\_\_\_\_ in wc  
MAIN BURNER ORIFICE: \_\_\_\_\_ # DMS  
PILOT ORIFICE # \_\_\_\_\_ OR \_\_\_\_\_ in diam.  
INSTALLER'S SIGNATURE:  
\_\_\_\_\_

NAME OF INSTALLER:  
\_\_\_\_\_  
  
ADDRESS:  
\_\_\_\_\_  
\_\_\_\_\_  
\_\_\_\_\_  
  
PHONE: \_\_\_\_\_

MANUFACTURED BY:  
SHERWOOD INDUSTRIES LTD.  
6782 OLDFIELD RD. SAANICHTON, BC, CANADA V8M 2A3  
www.enviro.com  
Winter 2021  
C-14873