

7600

Installation & operating instructions for USA & Canada



Read the entire manual
before installing and using
your Morsø stove

A French version of the manual can be downloaded at www.morsona.com

Welcome to Morsø

Thank you and congratulations on the purchase of your new Morsø heater.

Morsø has been at the forefront of cast iron wood heater design since 1853. Each and every heater is hand built by skilled crafts-people using the best materials available. However, to extract the best performance, warmth and comfort from your heater it is essential all the installation requirements detailed within this manual are met. Please take the time to read this manual cover to cover before installation.

Optional Accessories

Morsø offers a comprehensive selection of accessory products (fire tools, fuel buckets) that extends Form & Function to the hearth. A wide range of maintenance products is also available to keep your new Morsø heater in tip-top condition.

For optimum use of your Morsø heater we highly recommend using the **Morsø Wood Moisture Meter** to ensure good fuel quality as well as the **Morsø Stove Thermometer** that indicates the correct operating temperature.



Morsø 7600-series was designed by Monica Ritterband, currently one of Denmark's most sought-after designers. Monica Ritterband is known for her pioneering designs, which all take their starting point in her unique universes and totally special, organic language of form and lines. Thus, the Morsø 7600 was also created in this way – it is completely unique with its circular form, round feminine transitions and its huge glass window, the biggest in Morsø's history of stoves.

| Technical Specifications | | Features |
|---|----------------------|---------------------------------|
| Maximum Heat | 35,000 BTU/hr | Danish Design and Function |
| Heat output range (Lab test) | 10,875-21,267 BTU/hr | Finest Cast Iron construction |
| Test fuel load | 6 lbs | Chrome iron internal castings |
| Particulate Emission | 4.4 gm/hr | Pre-heated clean-glass system |
| Log size | 11" | Non-catalytic combustion system |
| Max. Area Heated | 1200 ft ² | Convection Heater |
| Firebox Dimensions | 13" W x 10½" D | Reversible flue collar |
| Firebox volume/capacity | 0.85 ft ³ | Vermiculite lining |
| Efficiency rating (as measured by LHV) | 75%+ | Ashpan |
| IRS Tax Credit (under American Recovery and Reinvestment Act of 2009) | Eligible | 10-Year Limited Warranty |
| Outside air supply | Available | Low smoke emissions |
| Mobile home approved | Yes | Made from 98% recycled iron |
| Washington State | Compliant | Recycled packaging |
| Basic Clearance (using single wall pipe top vent) | | |
| Stove to side wall | 15" | |
| Stove to rear wall | 1" | EPA Approved |
| Stove to corner | 2½" | |
| See installation manual for other configurations | | |



Morsø 7642



Morsø 7644



Morsø 7648

Table of Contents

| | |
|---|-----------|
| • Technical Specifications | 2 |
| SAFETY NOTICES & STANDARDS | 5 |
| • Safety Notice | 5 |
| • Standards | 5 |
| • Safety Notices | 6 |
| INSTALLATION | 7 |
| • Preparation | 7 |
| • The chimney / flue system | 7 |
| • Clearances to combustible surfaces | 13 |
| • Floor Protection | 15 |
| • Mobile Home Installation | 16 |
| OPERATION | 18 |
| • Choosing your fuel | 18 |
| • How to light your stove | 20 |
| MAINTENANCE | 23 |
| • Ceramic glass replacement | 24 |
| • Internal Parts | 25 |
| - Removing the baffle assembly | 25 |
| - Door Rope Gasket | 25 |
| - Cleaning the Heater and the Chimney Connector | 25 |
| - Ash disposal | 25 |
| • Chimney sweeping & inspection | 26 |
| WORDS OF WISDOM | 27 |
| SPARE PARTS | 28 |

Safety Notices & Standards

Safety Notice

Please read the entire installation and operation manual before you install and use your new solid fuel heater. If this appliance is not properly installed, a house fire may result. To reduce the risk of fire, carefully follow the installation instructions. Failure to follow instructions may result in **property damage, bodily injury, or even death.**

Contact local building or fire officials about restrictions and installation inspection requirements in your area. Save these instructions for future reference.

MORSØ JERNSTØBERI A/S . DK-7900 NYKØBING MORS, Denmark
E-Mail: heaters@morsoe.com • Website: www.morsoe.com

Tested and listed by OMNI-Test Laboratories, Inc, Portland Oregon.
Tested to U.S. Standards ANSI/UL-1482 and Canadian Standards ULC S627

The heater is listed for burning wood only. Do not burn other fuels.

Standards

The Morsø 7600-series meets the U.S. Environmental Protection Agency's emission limits for wood heaters sold on or after July 1, 1990 (EPA Phase 2)

The Morsø 5660 Standard Insert has been tested by OMNI-Test Laboratories, Inc. The test standards are ANSI/UL-1482 for the United States and ULC S627 for Canada.

The heater is listed for burning wood only. Do not burn other fuels

Under specific test conditions this heater has been shown to delivery heat at rates ranging from 10,875 to 21,267 Btu/hr.

Always check Local Building Codes

When installing or operating your Morsø heater always follows the instructions detailed within this manual. Please store in a safe place and make them available to any person who requires it for future inspection or servicing.

A building permit may be needed to install a solid fuel heater in your locality. In the US, Standard NFPA211 may apply, in Canada CAN/CSA-B365-M93 may apply. For clarification consult your local building inspector.

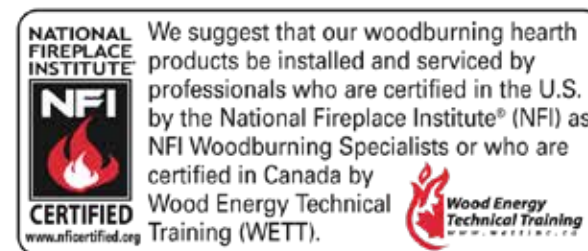

Safety Notices

- This room heater is approved for wood fuel only; Do not burn any other fuel or garbage.
- If this wood heater is not installed properly, it may result in a house fire. To reduce the risk of fire follow the installation and operating instructions carefully. Failure to properly follow the installation and operation instructions may result in property damage, bodily injury or even death.
- Never use chemical fire starters or fluid to start your fire.
- Never burn garbage or flammable fluids.
- Never use gasoline, gasoline-type lantern fuel, kerosene, charcoal lighter or fluid or similar liquids to start or freshen up a fire in this heater. Keep all such liquids away from the heater while it is in use.
- Where installation issues are not addressed in this manual, consult your local building or fire officials and where necessary defer to standards NFPA 211 in the US, or CAN/CSA-B365-M93 in Canada.
- Do not connect this wood heater to any air distribution duct or system and do not install into a chimney shared with another appliance.
- **During it's operation your wood heater will get hot;** Always make provision (fire guard) to adequately protect children, the infirm or inflammable materials from hot surfaces. These hot surfaces will cause skin burns if touched.
- Never allow your wood heater to overheat; Operate only within the guidelines set out in this manual.
- Never operate this heater if any of the components (inc' glass) are cracked or broken. Replace broken or damaged component before use.
- Always install smoke and carbon monoxide detectors in your home. Adhere to the recommended positioning and maintenance instructions.
- Cooktop hoods, clothes driers, and similar extraction units can have a detrimental effect on chimney draft; Avoid installing your wood heater in areas where there are present unless you are able to provide sufficient or additional outside air to the room.
- Your heater should be properly sized to the immediate area you need to heat; An under-sized heater may not deliver the required heat output without overheating and an oversized heat may produce too much heat.
- Always use approved chimney and chimney lining materials.
- Your chimney should be inspected and swept by an approved chimney sweep at least once every year, dependent upon usage.

Installation

Preparation

We recommend installation be performed by an approved Morsø dealer or fully qualified installer. In any event, Morsø heaters are very heavy and we recommend the installation be performed by two people.

Always consult your local building or fire officials to determine if any permits are required for installing a solid fuel heater in your area. You may also need to inform your Homeowners Insurance Company.

After unpacking, check that fire bricks or liners are firmly in position and have not shifted in transit. Check also that the air control works freely.

Before starting the initial fire, make sure that the baffle is placed correctly.

The chimney / flue system

Note that the flue system must be independently secured and must not rely on the stove for support.

Use a residential type masonry or listed type HT factory-built chimney.

High Temperature (H.T.) Chimney Standard UL-103-1985 (2100° F.) or a code-approved masonry chimney with flue liner for the USA, and High Temperature (650°C) Standard ULC S-629 for Canada.

The internal dimensions of the chimney connector and chimney must not be less than 6 inches diameter (or equivalent cross section), and should not be significantly larger than this. Too large a section will tend to allow the flue gases to cool excessively, causing sluggishness or unpredictability in the stove's performance.

We recommend the length of the chimney system should be at least 16 feet (not required) above the stove in normal domestic situations, measured from the flue collar to the top of the chimney. Local conditions for example - roof constructions, large trees nearby and high altitude, may influence the chimney draft. Therefore, contact your local professional chimney sweep or your Morsø dealer prior to installation.

Typical Factory-Built or Masonry Chimney Installations

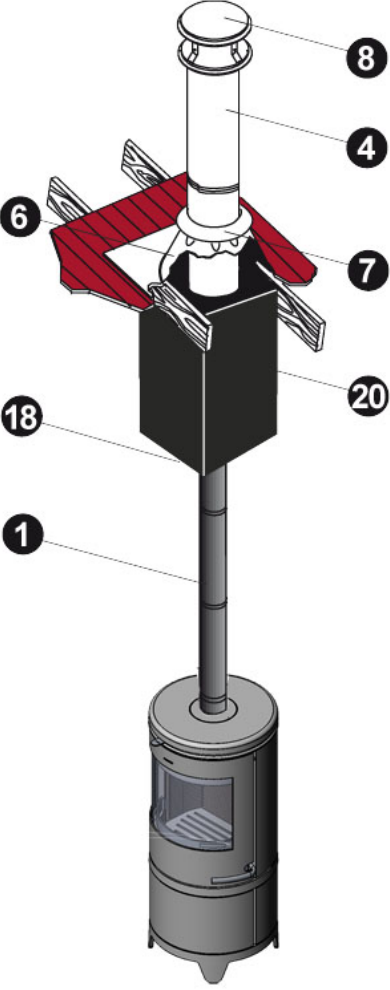
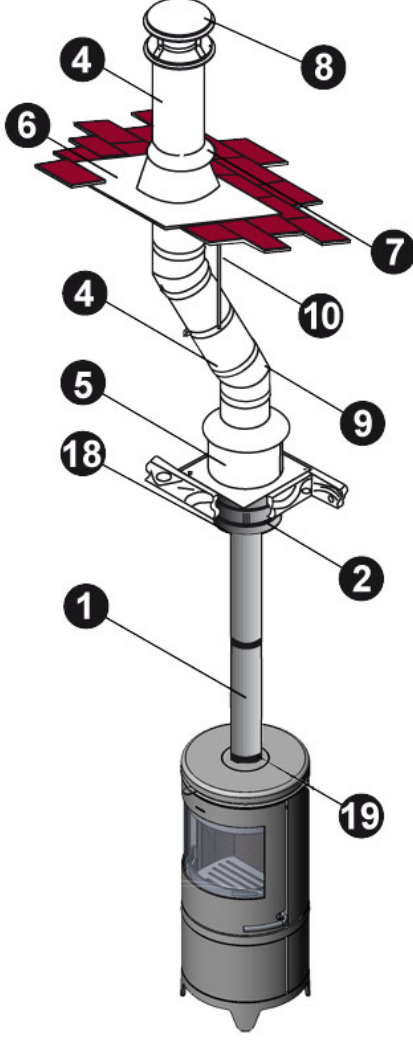
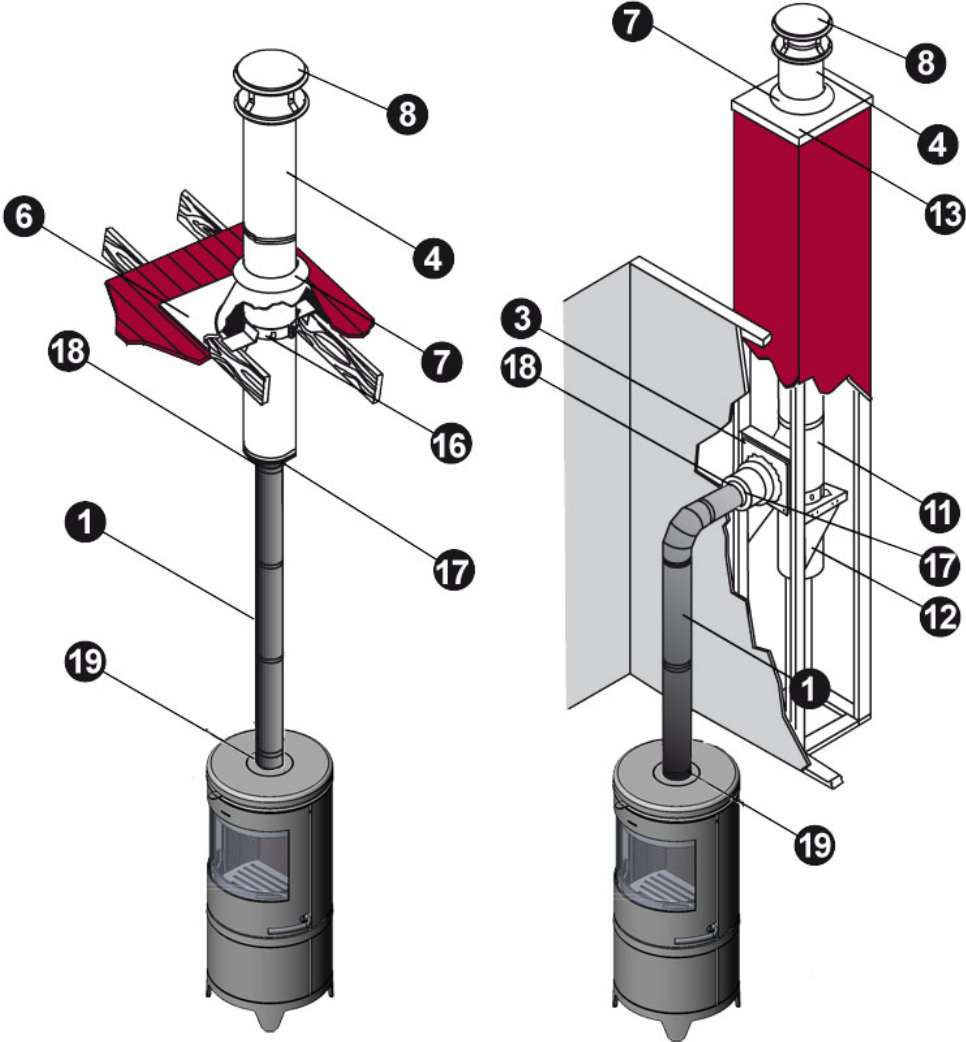

See page 10 for key

See page 10 for key

| Installation Key | | | |
|------------------|--------------------------------------|----|--|
| 1 | DVL or DuraBlack 11 Tee with Tee Cap | 11 | Tee with Tee Cap |
| 2 | Ceiling Support Box | 12 | Tee Support |
| 3 | Wall Thimble | 13 | Chase Top Flashing |
| 4 | Chimney Pipe | 14 | Base Tee/Double Tee |
| 5 | Attic Insulation Shield | 15 | Anchor Plate or Anchor Plate with Damper |
| 6 | Flashing | 16 | Roof Support |
| 7 | Storm Collar | 17 | Finishing collar |
| 8 | Chimney Cap | 18 | DVL Adapter, DuraBlack Slip, Connector, or Snap-Lock Adapter |
| 9 | Elbow | 19 | Stove Adapter |
| 10 | Elbow Strap | 20 | Square Ceiling Support Box |

Refer to our Typical Installation drawings to select the appropriate component parts for your installation.

- DVL/DuraBlack Chimney Adapter must be used when connecting DVL pipe to a Ceiling Support Box or Finishing Collar. When connecting DuraBlack pipe, a DVL/DuraBlack Chimney Adapter, DuraBlack Slip Connector, or Snap-Lock Adapter must be used.
- Wall Thimble must be installed with an appropriate length of chimney pipe for all horizontal through-the-wall installations. To accommodate thicker walls, the telescoping pieces of the Wall Thimble can be separated, and a field-fabricated extension may be installed.
- Attic Insulation Shield must be used in all installations that pass through an attic, regardless of whether the attic is insulated or not.
- Firestop Radiation Shield must be used when a chimney passes through a floor or ceiling without a support box.

Note: Chimney Installation Diagrams supplied by kind permission of Simpson Duravent (Duravent.com). Components shown may differ from manufacturer to manufacturer.

Typical Installation

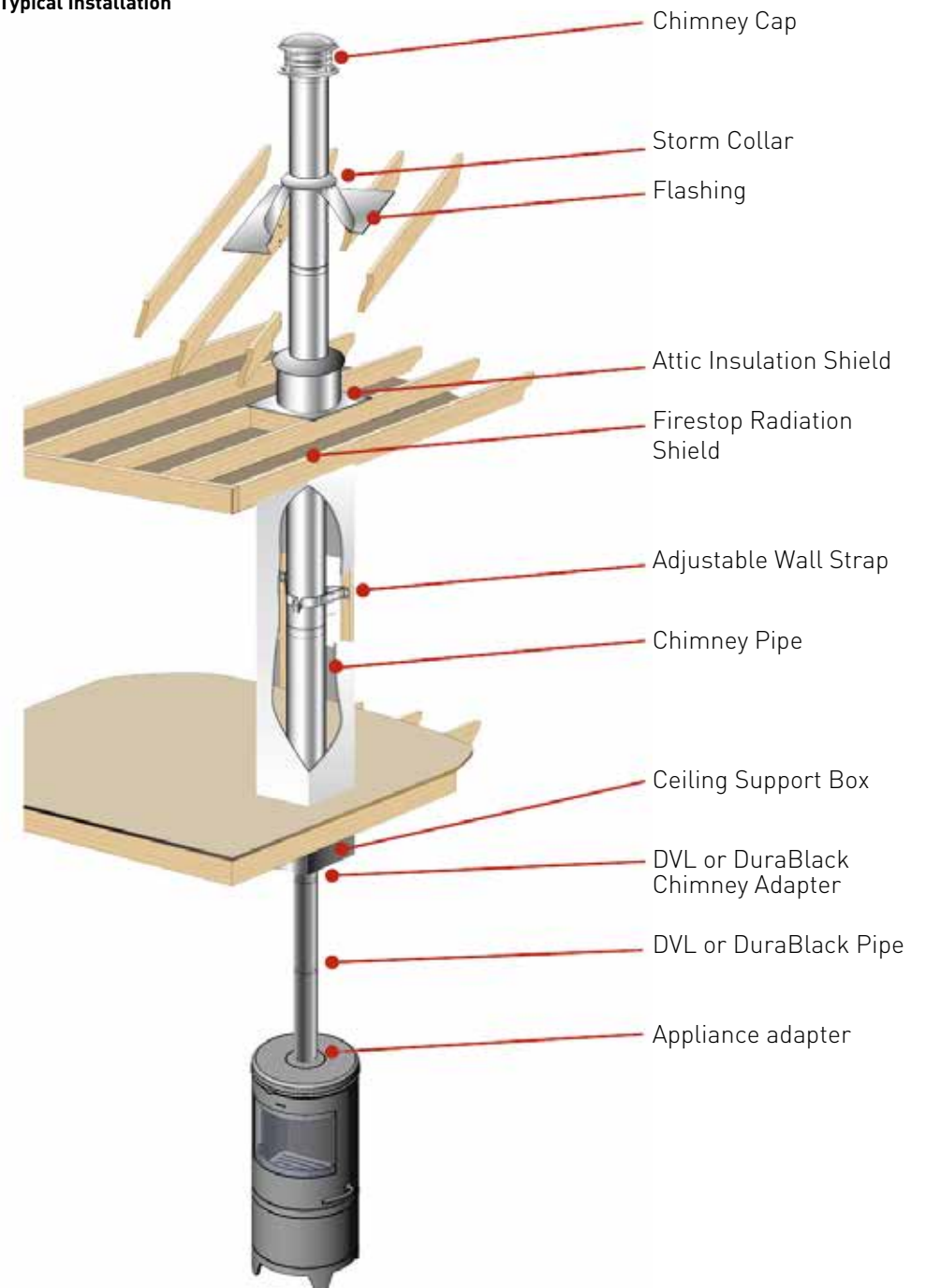

Flue Connection

The stove is supplied from the factory with round blanking plates blocking off the top and rear flue exits (behind the rear shield plate). A cast iron flue collar is placed inside the firebox during transit.

Use a 24 MSG black chimney connector or listed double wall chimney connector. Refer to local codes and the chimney manufacturer's instructions for precautions required for passing a chimney through a combustible wall or ceiling. Remember to secure the chimney connector to the product using a minimum of three screws to each adjoining section.

The flue collar can be fitted to the rear outlet. Simply knock out the round panel on the rear plate to reveal the cast iron plate. Untwist the blanking plate and the flue collar and swap their positions. Re-secure by pushing down and tighten the enclosed screws.

Position the stove and connect to the flue system.

Connection to the existing chimney - using single wall or double wall chimney connector.

A chimney connector is the double-wall or single-wall pipe that connects the stove to the chimney. The chimney itself is the masonry or prefabricated structure that encloses the flue. Chimney connectors are used only to connect the stove to the chimney.

Double-wall connectors must be tested and listed for use with solid-fuel burning appliances. Single-wall connectors should be made of 24 gauge or heavier gauge steel. Do not use galvanized connector; it cannot withstand the high-temperatures that smoke and exhaust gases can reach, and may release toxic fumes when under high heat. The connector must be 6 inches (150mm) in diameter.

If possible, do not pass the chimney connector through a combustible wall or ceiling. If passage through a combustible wall is unavoidable, refer to the sections on Wall Pass- Throughs. Do not pass the connector through an attic, a closet or similar concealed space when installing the chimney connectors.

It is important to keep the flue gases moving smoothly in the right direction. Do not vent into a large void; rather form one continuous section all the way up. Use mild bends (e.g. 45° vs. 90°) rather than sharp angles where a change of direction is required. All parts of the venting must be accessible for cleaning purposes.

In horizontal runs of chimney, maintain a distance no less than 18 inches from the ceiling. Keep it as short and direct as possible, with no more than two 90 degree turns. Slope horizontal runs of connector upward 1/4 inch per foot (20 mm per metre) going from the stove toward the chimney. The recommended maximum length of a horizontal run is 3 feet (1 metre), and the total vertical length should be no longer than 8 feet (2.5 metres).

Information on assembling and installing connectors is provided by the manufacturer's instructions.

Be sure the installed stove and chimney connector are correctly distance from near by combustible materials. See the clearance paragraph page 13.

Where passage through a wall or partition of combustible construction is desired, the installation shall conform to CAN/CSA-B365.

Clearances to combustible surfaces

Distance to walls and lintel

When the stove is positioned near combustible materials, observe all current local and national building regulations with regards to clearances. Whatever regulations apply to your area, do not in any case install the stove within 8 inches of combustible materials from the sides or 16 inches above the top of the stove (fireplace installations require greater clearances above the stove - see below in the clearance chart). These distances may need to be increased if the materials (precious furniture) are sensitive to heat. Note also that wallpaper and other decorative materials may become detached with the effects of heat and care should be taken to ensure that they do not fall onto the stove in such an event. When the stove is positioned near non-combustible materials, a gap of 4 inches or more is recommended for cleaning purposes and to ensure that heat circulates around the stove and out into the room.

| Clearance Requirements | FREESTANDING RESIDENTIAL INSTALLATION TOP VENT using single wall connector | |
|----------------------------|---|---------|
| | USA | Canada |
| A. Sidewall to unit | 15" | 381 mm |
| B. Backwall to unit | 1" | 26 mm |
| C. Cornerwall to unit | 2½" | 64 mm |
| D. Sidewall to connector | 21" | 533 mm |
| E. Backwall to connector | 7" | 178 mm |
| F. Cornerwall to connector | 8½" | 216 mm |
| G. Unit to ceiling | 47" | 1194 mm |

Minimum clearances to combustibles:

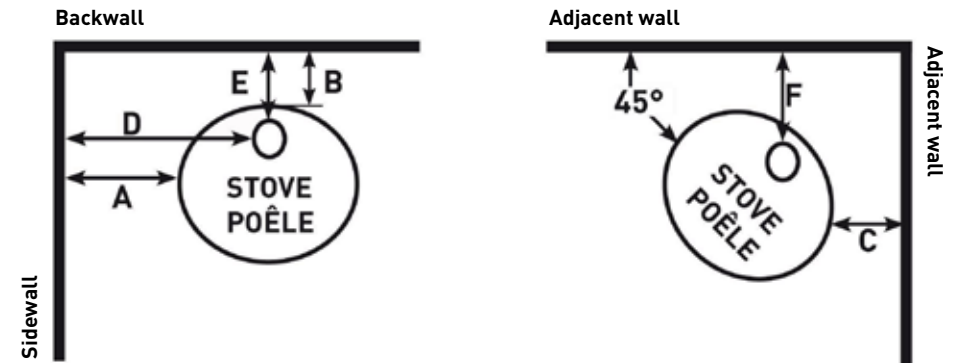

| Clearance Requirements | FREESTANDING RESIDENTIAL INSTALLATION TOP VENT using double wall connector | |
|----------------------------|---|---------|
| | USA | Canada |
| A. Sidewall to unit | 15" | 381 mm |
| B. Backwall to unit | 1" | 26 mm |
| C. Cornerwall to unit | 2½" | 64 mm |
| D. Sidewall to connector | 21" | 533 mm |
| E. Backwall to connector | 7" | 178 mm |
| F. Cornerwall to connector | 8½" | 216 mm |
| G. Unit to ceiling | 47" | 1194 mm |

| Clearance Requirements | ALCOVE INSTALLATION using double wall connector | |
|-----------------------------------|--|--------|
| | USA | Canada |
| A. Sidewall to unit | 15" | 381 mm |
| B. Backwall to unit | 1" | 26 mm |
| C. Cornerwall to unit | - | - |
| D. Sidewall to connector | 21" | 533 mm |
| E. Backwall to connector | 7" | 178 mm |
| F. Cornerwall to connector | - | - |
| G. Unit to ceiling | 33½" | 851 mm |
| W. Minimum alcove width | - | - |
| D. Maximum alcove depth | 32" | 813 mm |
| G. Alcove ceiling above stove top | 33½" | 851 mm |

MAXIMUM ALCOVE DEPTH 32" (813 MM)

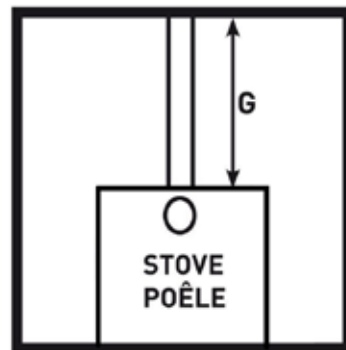
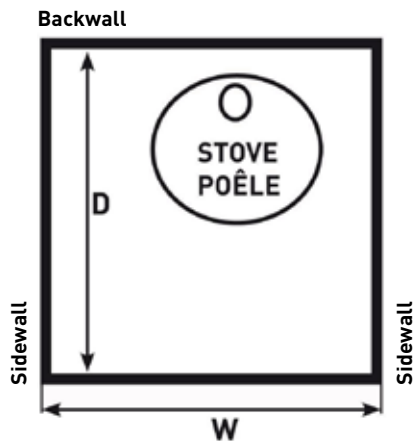

Floor Protection

| Floor protection requirements | NON -COMBUSTIBLE MATERIAL BENEATH STOVE | |
|-----------------------------------|---|--------------|
| | USA | Canada |
| A. Extending distance, back | - | 8" (200 mm) |
| B. Extending distance, right side | 6" | 8" (200 mm) |
| C. Extending distance, left side | 6" | 8" (200 mm) |
| D. Extending distance, front | 16" | 18" (450 mm) |

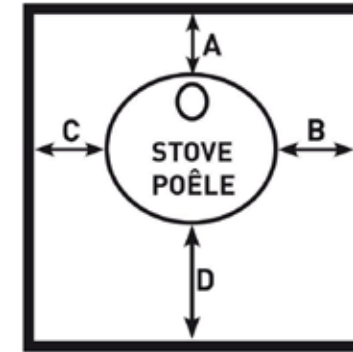

US:
FLOOR PROTECTOR MUST BE
NON-COMBUSTIBLE MATERIAL
IT MUST EXTEND FRONT/SIDE/REAR AS INDICATED

CANADA:
FLOOR PROTECTOR MUST BE
NON-COMBUSTIBLE MATERIAL
IT MUST EXTEND FRONT/SIDE/REAR AS
INDICATED

Mobile Home Installation

The Morsø 7600 can be installed in a mobile home if equipped with an outside combustion air kit, a terminal cap with a spark arrestor, and if it meets the following installation requirements:

- The stove must be secured to the mobile home structure by bolting through the hearth pad and into flooring.
7642 & 7644 are prepared for securing.
The 7648 requires you drill three holes in the floor at specific points (see diagram below).
- The stove must be installed with a listed Type HT chimney connector, HT Chimney, and terminal cap with spark arrestor. Never use a single wall connector (stovepipe) in a mobile home installation.
- Floor protection requirements in section 1.5 must be followed precisely.
- In Canada, this appliance must be connected to a 6" (152 mm) factory-built chimney conforming to CAN/ULC-629M, STANDARD FOR FACTORY BUILT CHIMNEYS. Floor protection as referenced in section 1.5 must be followed, as well as use of Canadian Floor Protector.
- Follow the chimney and chimney connector manufacturer's instructions when installing the flue system for use in a mobile home.
- Intake air piping can be installed through the floor into a vented crawl space or through the wall of the residence to obtain outside air.
- Install in accordance with 24 CFR, Part 3280 (HUD).
- NOTE: Top sections of chimney must be removable to allow maximum clearance of 13.5" from ground level for transportation purposes.

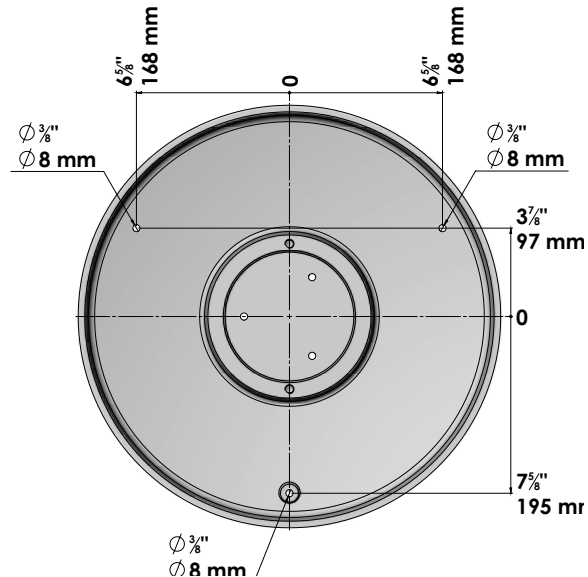

WARNING:
NEVER DRAW COMBUSTION AIR FROM A WALL, FLOOR OR CEILING CAVITY OR FROM ANY ENCLOSED SPACE SUCH AS AN ATTIC OR GARAGE.
DO NOT INSTALL IN A BEDROOM OR A ROOM WHERE PEOPLE SLEEP.

CAUTION:
THE STRUCTURAL INTEGRITY OF THE MOBILE HOME FLOOR, WALL, AND CEILING/ROOF MUST BE MAINTAINED (I.E., DO NOT CUT THROUGH FLOOR JOIST, WALL STUD, CEILING TRUSS, ETC.)

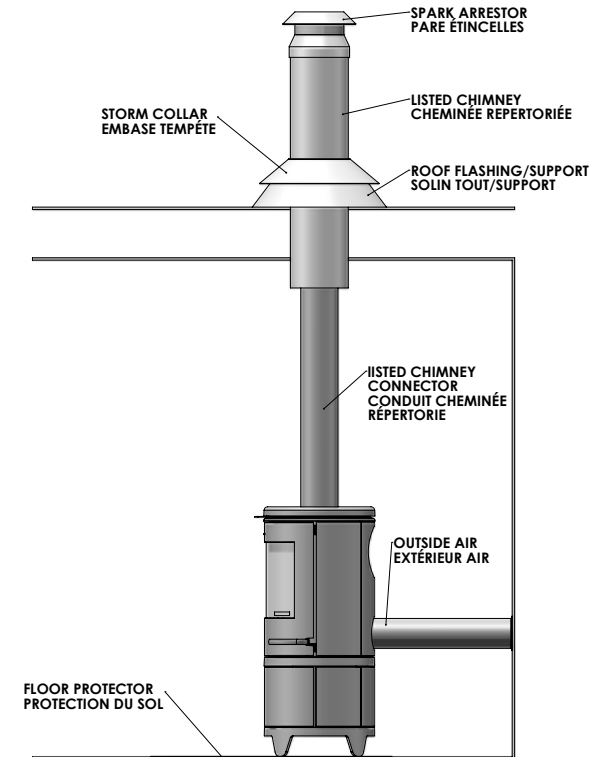

Acid Protection

If acid-washing the masonry around the stove, protect the stove surface with an acid-proof cover.

Outside Air Supply

Only mobile home approved heaters may be installed into mobile homes and it is a requirement that outside air is supplied directly to the heater.

However, in every residential situation where the room has poor air infiltration via doorways, windows and the like, providing a dedicated outside air supply may be required. By attaching a non-combustible conduit (ducting) directly to the air intake of the heater, outside air can be delivered directly to the combustion chamber. Some models may require an additional (optional) outside air kit. The conduit used for providing outside air should have a free space equal to but no less than 3" diameter.

Outside air is particularly important when the heater is to be installed into a well sealed room, or where an extractor hood or ventilation system interferes with the room's natural air pressure. Avoid placing the outside air supply onto a wall that that is usually subject to negative pressure from normal wind pattern.

Operation

Before you light your heater here are a few considerations.

Your new Morsø heater is approved for use with Solid Wood Fuel Only. DO NOT OVERHEAT. If the heater or chimney connector glows, your heater is overheating. Use Morsø stove thermometer for correct operating temperature (#62901200).

Have your chimney inspected and cleaned at least once a year by an approved and certified chimney sweep.

Be aware; if the heater is not operated or installed in accordance with the manufacturers instructions or the fuel quality is poor, creosote buildup may occur within the flue thus increasing the risk of a chimney fire.

To reduce the risk of smoke and flame spillage, operate the heater only with door(s) fully closed.

Caution:

Your heater will be hot while in operation. Keep children, the infirm, clothing and furniture protected at all times.

Choosing your fuel

All types of natural wood can be burned in your heater, but it must be well-seasoned and dry.

For the correct combustion efficiency and heat output, wood fuel should contain no more than 18% moisture; this can easily be checked by using the Morsø Wood Moisture Meter (part # 62929900).

When wood fuel is cut to length you should allow for an inch gap between the fuel and side walls of the firebox so as to ensure adequate circulation of the gases. Cut wood should also be split down middle to allow for the quick release of moisture.

To naturally season wood fuel, it should be stacked and stored under cover in an airy location where fresh air can move around the stack. Some soft woods may take as little as one good summer to season whereas harder woods such as oak, maple, and elm may require up to 18 months or more.

Avoid burning overly dry wood that is gray in color as under certain conditions it can cause performance problems, such as back-puffing and poor performance. Well seasoned wood will be light to hold and when looking at the ends it will show signs of cracking from the center outwards.

If your wood spits or sizzles when burned and your heater's door glass persistently clouds up, it is possible that your wood is not properly seasoned (although a poor chimney draft can also cause this).

Never use drift wood (from the sea) as salt content may cause corrosion; construction wood that may have been impregnated with chemicals should also be avoided.

Starting the first fire

When lighting your heater for the first time or after dormant periods, the initial fire should be fairly gentle so that the finish paint can cure and the main cast plates of the heater can expand gently and settle into position.

The heater paint cures at higher temperatures and it should be expected that during the initial firing process a slight odor will be emitted into the room therefore, it is important to ventilate the room well during this process.

The operating position of the air control lever (or dial) will vary and so will your loading intervals; both are dependent on several factors, your lighting technique, the chimney draft, the fuel used and the heat requirement etc.

Some basic techniques are outlined below.

In most models the heater is equipped with three air supplies:

Primary air is controlled by the air control lever situated beneath the ash lip or above the door, in some models, on the door. Primary air passes through internal channels where it is preheated and eventually washes at high speed down the back face of the door glass – the air-wash system. This super-heated air helps to achieve high combustion efficiency of the volatile gases driven from the fuel.

Secondary air is factory-set and enters the combustion chamber via the baffle assembly (or tubes) located under the roof of the firebox. This source of combustion air mixes with the volatile gases and given the right conditions, secondary combustion takes place making for very clean and low emissions. This air supply is constant and cannot be varied.

Pilot air or tertiary air enters the combustion chamber through a hole located behind the front bottom section of the fire opening (below the front grates). This air ensures the embers in the fire bed stay hot. Pilot air supply is factory-set and cannot be varied.

Lighting and loading procedure

When you are ready to light your heater, it is essential to quickly establish a chimney draft therefore the initial lighting process will require you to leave the door cracked open for a few minutes. For added safety, it is of course essential that you pay close attention to the heater at this point.

During the process it is also important to create and maintain a good bed of ash (1" thick) in the fire bed. To achieve this be prepared to use 4-6lbs of dry kindling (thin sticks) during the initial lighting process.

Before your start the lighting process fully open the primary air control lever (or dial).

How to light your stove



1. How to light the stove
As shown in the picture to the left you need the following:
2 fire lighters (or 5-10 scrunched-up sheets of newspaper)
1 kg of dry kindling
Approx. 2-3 lbs. of chopped firewood



2. You should always have an insulating layer of ashes from previous firings in the bottom of the fire chamber. 1" of ash is a suitable base for the wood. Start by placing a couple of logs, approximately 1 lb., in the bottom of the burn chamber.



3. Arrange the kindling
Place approximately 2 lbs. of dry kindling wood on top of the logs. Place a couple of kindling bags or newspaper just below the top layer of kindling wood.



4. Lighting the kindling
Light the kindling bags or newspaper



5. Before lighting, fully open the primary air supply. The flames work their way slowly downwards from the top.

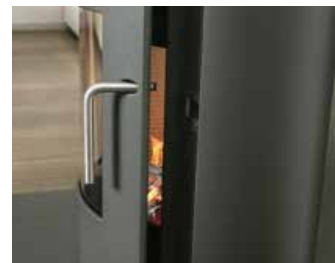

6. Leave the stove door ajar
After 5-10 minutes the heat will produce draft through the chimney, and the door can be shut.



7. Embers
After approximately 45-60 minutes, the last flames go out, and a good layer of embers has been formed. More wood should be added while there are still glowing embers. Use a poker or ash scraper to spread the embers, but ensure that most of them are positioned at the front of the stove.



8. Re-Fuelling
Place three pieces of wood of approx ½ lb. each and approx. 9,8" long over the embers in a single layer, with a distance of approx. ½" between each piece. When the air controls are opened fully, and the door is closed, the wood will ignite within 2-3 minutes.



9. Optimal combustion
Finally, adjust the air supply control to the required position to give optimal combustion. Maintaining a good fire box temperature will ensure secondary combustion of the smoke and gases giving a clean and efficient burn. The stove should be refuelled only while glowing embers remain.



10. How much ash should be left in the stove?
Keep a 1" thick layer of insulating ash. The ash layer insulates the bottom of the stove in the same way as the fire bricks or vermiculite board on the sides of the stove. This ensures a high combustion temperature which contributes to a cleaner more efficient combustion.

Furthermore, the ash layer protects the grate against premature failure and increasing its life expectancy. Empty the ashpan as required. Store any hot ashes in a suitable non-combustible bucket until all embers are fully extinguished, cold ash can then be disposed of with the rest of your household waste.

Do not for any reason attempt to increase the air flow through your heater by altering or tampering with the air control mechanism. This could lead to serious safety and health hazards.

Warning: Fireplace heaters must never be left unattended when the door(s) is open. If the door is left partly open, gas and flames may be drawn out of the heater's opening thus increasing risks from both fire and smoke. We recommend you to fit smoke and carbon monoxide detectors in the room where the heater is installed.

DO NOT OVERHEAT THIS HEATER. Overheating may cause a house fire, or can result in permanent damage to the heater. If any part of the heater glows, you are overheating. The maximum recommended weight of wood fuel per load is 2 kg/h/4.5lbs (approx 3 split logs).

Under normal firing, the average flue temperature on the single wall stove pipe, measured 8" (200 mm) above the stove, is approx. 300° C (550°F). The maximum flue temperature on the stove pipe must not exceed 450° C (750°F). If the flue temperature exceeds 450°C (750°F), it is considered as over firing and may cause premature wear and tear of the stove. Damaged caused by overheating is not covered under warranty.

To help gauge the correct running temperature of your stove, we recommend you use the Morsø Stove Thermometer (part # 62901200). The Stove Thermometer magnetically attaches onto the stove pipe approx 8" (200 mm) above the stove's top plate and measures the surface temperature of the stove pipe. Please see your authorized Morsø Dealer for availability.

Chimney Draft

If smoke or fumes spill from your heater when lighting up and reloading, or if the fire simply will not respond, a poor chimney draft is almost certainly to blame. (In a very few cases, there may be insufficient fresh air getting into the room - see installation advice above). Take advice from your dealer or chimney expert on how best to upgrade your flue system and improve the draft.

Simple rules for controlling your heater

If you want less heat, put fewer logs on the heater and reduce the amount of air however, it is extremely important to maintain a good layer of glowing embers throughout the combustion process.

Low heat output = less wood & less air
High heat output = more wood & more air

Soot particles will accumulate on the glass and vermiculite bricks if the heater is operated too low or if your wood is not well seasoned.

Maintenance

A clean well maintained heater is essential for good health and a safe home environment. Your heater should be properly inspected at least once a year.

When performing any maintenance procedure always wear protective clothing and always wear safety goggles and gloves.

Exterior Maintenance

The heater's outer surface is painted with a heat-resistant paint. Generally, it is best kept clean by using vacuum cleaner with a soft brush attachment or, by wiping with a damp lint-free cloth. Over a period of time, the dark gray painted surface may become lighter. The surface can easily be restored using our CFC-free aerosol touch-up paint (product code - 62902316DG) Morsø stove paint is available through your approved Morsø dealer.

In accordance with the instructions, this can be applied in minutes. Be aware however, that the new coat of paint will need to go through the curing process as described earlier thus, you will need to ventilate the room when lighting the heater for the first time.

Internal Maintenance

Transparent Ceramic Glass

If the heater is operated in accordance with the instructions, there should be little or no dirt accumulation on the glass surface. If particles have settled during operation, it is probable that this will burn away as the fire temperature is increased.

For heavier deposits that will not burn off, Morsø glass cleaner (product code 62902600) can be applied when the glass is cold. Note: never use abrasive cleaners or scrapers on the glass surface.

Why does my glass get dirty?

- Fuel too wet and/or too thick.
- Fuel not split.
- Combustion chamber temperatures too low – maintain glowing coal bed.
- Poor chimney draft.
- Under firing the stove.

Safety Note: If the glass breaks, replace it with genuine Morsø ceramic glass immediately. Do not use your heater with a cracked or broken glass; this can lead to overheating.

Installing the glass is relatively simple however; you should never install the ceramic glass when the heater is in operation.

Ceramic glass replacement

Ceramic glass cannot be recycled because it has a higher melting point than ordinary glass. If ceramic glass is mixed with ordinary glass, the recycled material is spoiled and the recycling process may be halted. Ensure the heater's glass does not end up with ordinary recycled waste. It should be presented separately to your local recycling center as ceramic glass.

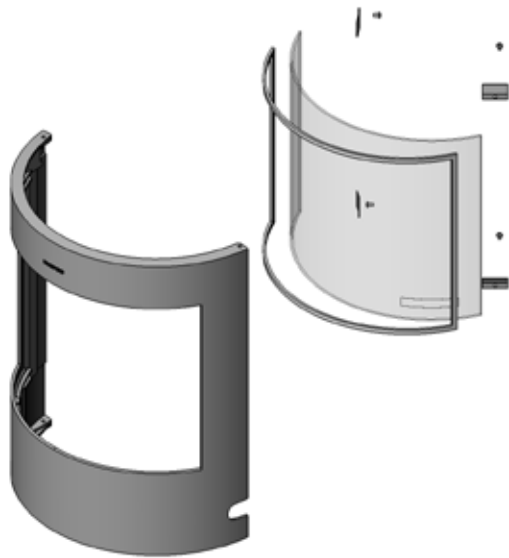

Replacement procedure

1. Detach the door from the body (See door removal section) and place face-down on a protective, non-abrasive surface.
2. Unscrew the screws that hold the glass clips. If the stove has been used for a number of years the screws may be tough to remove. **DO NOT FORCE THEM.** If the screws are tight, try applying heat (blow-torch) directly onto the screw head.

In the event that a screw does sheers off remove the remaining thread by drilling down its center with 1/8 inch high speed steel drill bit. Smaller drill bits may be successful, but do not use a larger bit. Make sure the bit stays away from the edge of the screw thread as this may damage the thread in the door casting.
3. Remove the old ceramic gasket material and clean the surface beneath with wire wool or emery paper to remove any loose particles.
4. Place the new gasket material in position around the perimeter of the window area, making sure to pinch it in such a way that all four sides make a continuous seal. Leave no gaps.
5. Place the new ceramic glass in position onto the new gasket and fasten by hand using new screws.
6. Finally, give each of the screws an extra half turn or so, just enough that the glass is held tight and will not dislodge when cleaning. **IMPORTANT!** Do not over-tighten the screws as this may put excessive pressure on the glass, resulting in cracking. To reduce the risks of accidental breakage avoid striking the glass, slamming the door or closing it onto a protruding log.

Internal Parts

The flame-path equipment - consisting of firebricks/vermiculite liners, bottom and front grates, ceramic glass, baffle plate assembly, pilot air assembly and chimney connector collar are the main components that are subjected to the rigors and heat of the fire; as a result it should be expected that these parts will need to be replaced from time to time as a matter of routine.

NOTE: The flame-path equipment, the ceramic rope and the paint finish are not covered by the Morsø manufacturers warranty.

Replacement parts can be purchased through your approved Morsø dealer. We recommend that all damaged or distorted parts be replaced as soon as possible to avoid collateral damage.

Should the baffle plate assembly become distorted from overheating, the combustion system will no longer function properly and the heater's efficiency will be severely compromised. Replace it as soon as possible.

Removing the baffle assembly

If the baffle is damaged or warped due to overheating, it is vital to replace it at once. First, carefully remove the vermiculite liners from the internal sides of the combustion chamber (firebox). Then, loosening the 3 x M6 allen screws that secure the baffle assembly in place; these are located along the internal back wall of the firebox. The baffle can now be carefully lifted and removed from the stove through the door.

The new baffle should be fitted and fastened before the side bricks are replaced. Ensure that all parts are fitted correctly before lighting up the stove.

Door Rope Gasket

The ceramic rope gasket around the perimeter of the door(s) may harden over a period of time. It should be checked for air-tightness at least once every year.

To check for air-tightness simply run a lit incense stick around the perimeter of the door when the stove is in operation; if the fine trail of smoke is drawn into the stove at any point, the gasket needs replacing. Alternatively, close the door(s) onto a slither of paper; if the paper can be easily removed with little force, it's time to change your door gasket.

Genuine Morsø door rope gasket kits (inc' adhesive) are available from your approved Morsø dealer.

Cleaning the Heater and the Chimney Connector

It is recommended that the area above the baffle plate assembly and around the chimney connector collar is inspected once a month for any soot or debris collection. If soot or debris is allowed to accumulate in this area, it could adversely affect the chimney draft and general operation. Typical symptoms of blockage are poor and sluggish draft, smoke spillage when opening the door, dirty glass and dirty firebox liners.

In any case the chimney should be inspected at least once every year, preferably in the summer to ensure that other blockages such as birds nest have not occurred.

Ash disposal

The level of ash-removal is dependent upon the level of use, the type of wood burned and the strength of chimney draft. A 1" ash bed should be maintained during general and excess ash should be removed when necessary.

Where the heater is equipped with an ash pan, excess ash should be emptied regularly. A full ash pan allowed to build up underneath the bottom grate could trap heat and lead to premature failure of the grate/pilot air assembly.

Caution:

Never empty ash when the heater is in operation.

Never use your household or shop vacuum cleaner to remove ash from the heater as it may still contain hot coals.

Always dispose of ash in a metal container.

Creosote formation

Your Morsø heater is equipped to burn the wood cleanly and efficiently however, if the chimney draft is poor or when wood is burned too low or too slowly, tar and other organic vapors can be produced and when combined with expelled moisture from the fuel, hazardous creosote is formed. The hazard is worsened when the creosote vapors condense inside cool chimney and the risk of a chimney fire is dramatically increased.

A monthly inspection of the flue is highly recommended.

Chimney sweeping & inspection

No matter how often you use your Morsø heater you should establish a monthly inspection routine of the heater and chimney system especially during the heating season.

Perform a chimney inspection when the heater is not in use. Using a mirror, look up through the chimney connector collar and look for visible signs of creosote build-up.

If you unable to inspect the flue system through the heater, it must be disconnected from the chimney connector to provide better viewing access.

Cleaning the chimney must be done using a brush the same size and shape as the flue liner or chimney system. Run the brush up and down the liner several times until all soot deposits have fallen to the bottom of the chimney where they can be removed through a clean-out door or from inside the heater (if still connected) using a vacuum cleaner.

Some models may require baffle removal (see page 25)

The chimney connector should be cleaned in a similar way using a stiff wire brush. This procedure might be better performed outside. Reinstall the connector sections after cleaning, making sure to secure the joints between the individual sections with sheet metal screws.

If you cannot inspect or clean the chimney yourself, contact your local certified chimney sweep or your approved Morsø Dealer.

If you do experience a chimney fire, you must act promptly

- 1. Completely close the primary air control.**
- 2. Ensure ALL persons have vacated the building.**
- 3. CALL THE FIRE DEPARTMENT.**

Annual maintenance

Prior to every heating season you should thoroughly clean and inspect the entire installation, repairing any damage, and replace any parts that show signs of wear & tear.

Thoroughly clean and inspect the chimney and chimney connector.

Have a contractor make any necessary repairs to a masonry chimney.

Check door & ceramic glass gaskets for wear or compression and replace if necessary.

Check the glass for cracking; replace if needed.

Check door and handles for tightness and adjust if needed.

Leaving the heater for extended periods**Important notice:**

When the heater is to be left unused for a long period of time (summer months etc) it is essential to clean it out thoroughly and leave the primary air control lever (or dial) open to allow airflow around the combustion chamber and chimney. Ventilating your heater and chimney will prevent excessive corrosion from moisture present in the chimney.

Make sure that the chimney has adequate protection from the rain and that rain water cannot come into contact with the heater; install a chimney rain cap, but do not under any circumstances block off the flue completely.

Warning: If moisture is allowed to settle within the heater, rust will form. As it takes a grip rust will cause cast iron to swell. This can lead to undue pressure on the plate joints and in turn may result in damage to the heater.

Words of wisdom

It is good practice to thoroughly clean the heater immediately after the heating season. Adding a desiccant, such as kitty litter into the heater bottom will help absorb excess moisture during the summer months. However, be sure to remove this prior to the heating season.

Thank you for choosing Morsø.

We hope you have many years of carefree warmth in its company. Some initial experimentation with loading and running techniques will help decide your normal routine. If you still have any questions after this short learning phase, please refer to your approved Morsø dealer who should be able to help

If for any reason you require further assistance, please contact us in writing at the address on the front of this manual.

Spare Parts

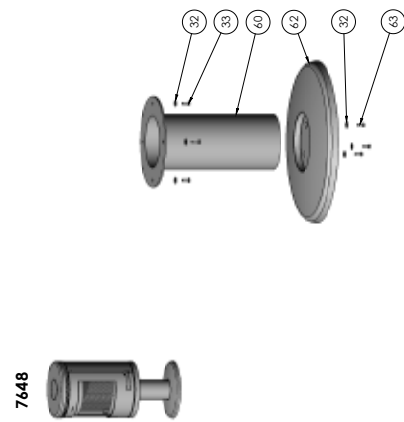
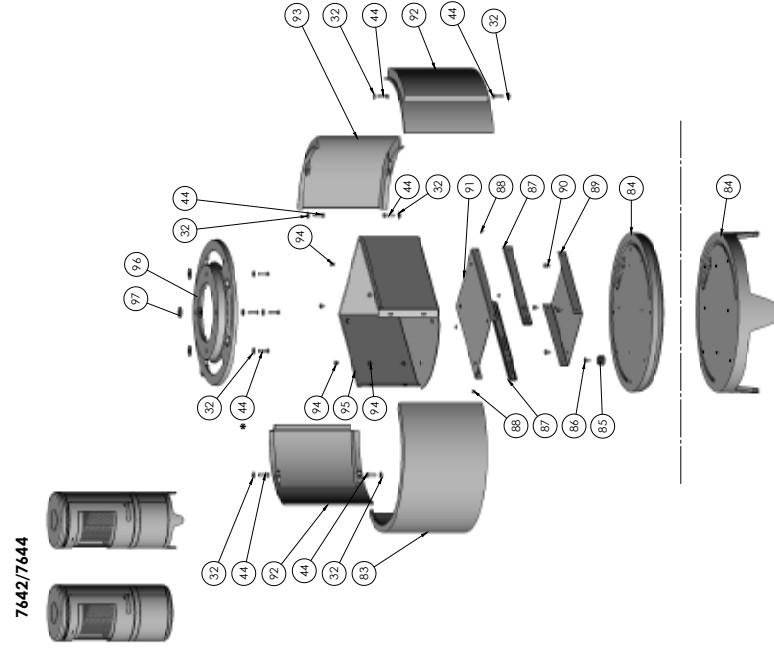
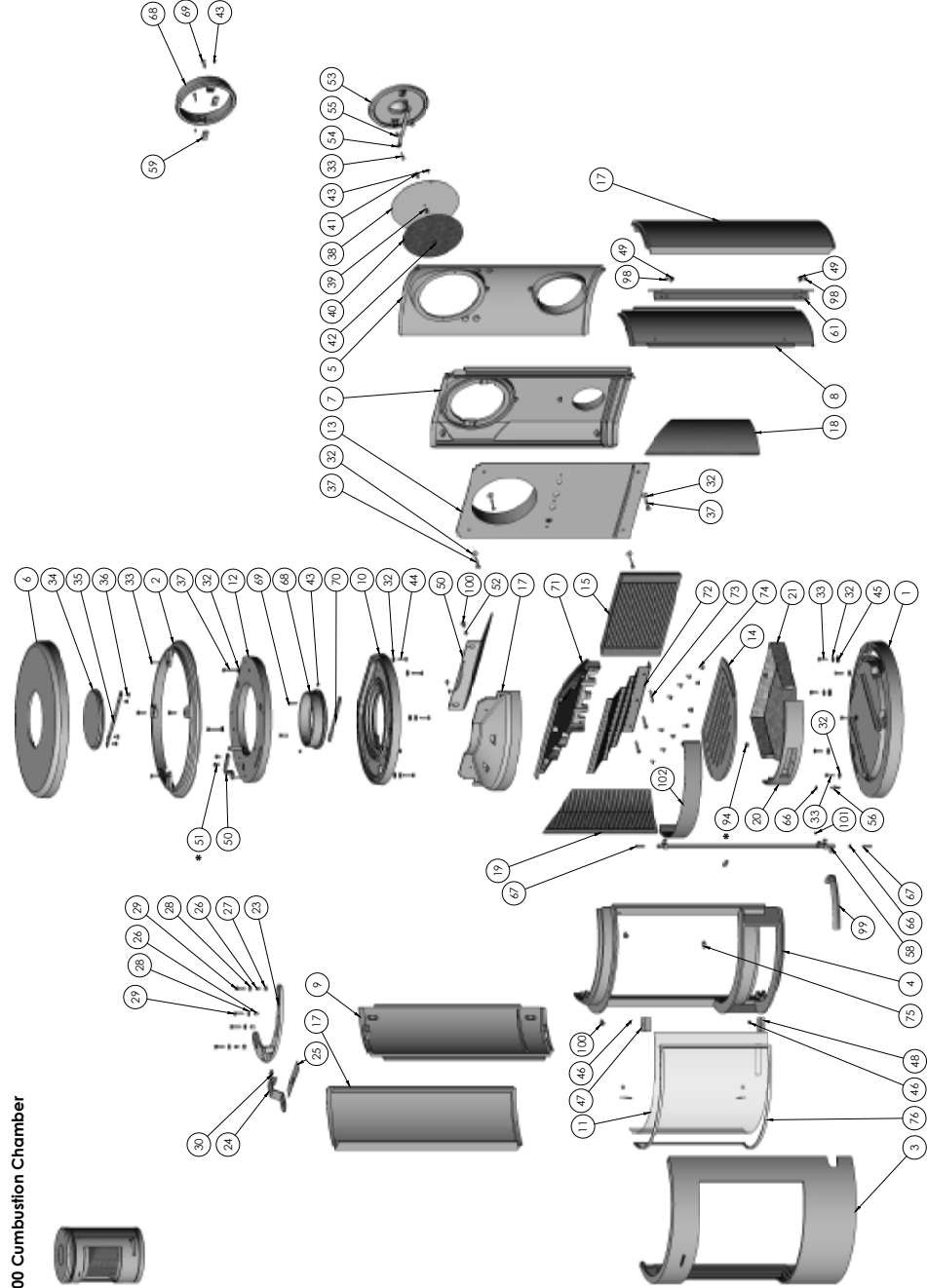

| POS.NR.: | Parts: | 7642 NA | 7644 NA | 7648 NA | POS.NR.: | Parts: | 7642 NA | 7644 NA | 7648 NA |
|----------|---------------------------|----------|----------|----------|----------|----------------------------|----------|----------|----------|
| 1 | Base plate | 447601xx | --- | --- | 53 | Cover | 442610xx | 442610xx | 442610xx |
| 2 | Top frame | 447607xx | 447607xx | 447607xx | 54 | Bar | 545006 | 545006 | 545006 |
| 3 | Door | 447603xx | 447603xx | 447603xx | 55 | Distance tube | 545007 | 545007 | 545007 |
| 4 | Front frame | 447656xx | 447656xx | 447656xx | 56 | Plug f. Door | 71760700 | 71760700 | 71760700 |
| 5 | Rear plate, outside | 447610xx | 447610xx | 447610xx | 57 | Fittig f. Door | 71760600 | 71760600 | 71760600 |
| 6 | Top plate, outside | 447611xx | 447611xx | 447611xx | 58 | Fitting f. Handle | 71761100 | 71761100 | 71761100 |
| 7 | Rear plate, inside | 44760400 | 44760400 | 44760400 | 59 | Fitting for Flue Collar | 44256700 | 44256700 | 44256700 |
| 8 | Side plate, inside, right | 447657xx | 447657xx | 447657xx | 60 | Pedestal | --- | --- | 547605xx |
| 9 | Side plate, inside, left | 447630xx | 447630xx | 447630xx | 61 | Fittig f. Door | 71762400 | 71762400 | 71762400 |
| 10 | Top plate, inside | 447605xx | 447605xx | 447605xx | 62 | Foot, f. Pedestal | --- | --- | 447616xx |
| 11 | Glass | 79760100 | 79760100 | 79760100 | 63 | Screw | --- | --- | 731616 |
| 12 | Air Canal, top | 44761500 | 44761500 | 44761500 | 66 | Washer | 746006 | 746006 | 746006 |
| 13 | Air Canal, rear | 44765400 | 44765400 | 44765400 | 67 | Screw | 739625 | 739625 | 739625 |
| 14 | Intermediate plate | 34761200 | 34761200 | 34761200 | 68 | Flue Collar | 443441xx | 443441xx | 443441xx |
| 15 | Brick, back | 79760700 | 79760700 | 79760700 | 69 | Screw | 743625 | 743625 | 743625 |
| 16 | Air Canal, front | 447613xx | 447613xx | 447613xx | 70 | Stop Bar | 544541 | 544541 | 544541 |
| 17 | Side plate, outside | 447609xx | 447609xx | 447609xx | 71 | Baffle plate, cast iron | 34762700 | 34762700 | 34762700 |
| 18 | Brick, side, right | 79760300 | 79760300 | 79760300 | 72 | Baffle plate, stainless | 71762200 | 71762200 | 71762200 |
| 19 | Brick, side, left | 79760400 | 79760400 | 79760400 | 73 | Screw | 74163504 | 74163504 | 74163504 |
| 20 | Ash tray, front | 447617xx | 447617xx | 447617xx | 74 | Screw | 74160804 | 74160804 | 74160804 |
| 21 | Ash tray | 71760400 | 71760400 | 71760400 | 75 | Jet, pilot air | 71762300 | 71762300 | 71762300 |
| 22 | Screw | 73861800 | 73861800 | 73861800 | 76 | Tightening tape, f. glass | 79074200 | 79074200 | 79074200 |
| 23 | Secondary Damper | 71760100 | 71760100 | 71760100 | 83 | Door bottom part | 447624xx | 447624xx | --- |
| 24 | Secondary Handle | 71760200 | 71760200 | 71760200 | 84 | Base plate, bottom section | 447629xx | 447628xx | --- |
| 25 | Close plate, sec. Damper | 71760300 | 71760300 | 71760300 | 85 | Rubber Stop | 79082007 | 79082007 | --- |
| 26 | Distance tube | 71810200 | 71810200 | 71810200 | 86 | Screw | 742612 | 742612 | --- |
| 27 | Distance tube | 71810300 | 71810300 | 71810300 | 87 | Ball track | 79082006 | 79082006 | --- |
| 28 | Washer | 736106 | 736106 | 736106 | 88 | Pop rivet | 74700300 | 74700300 | --- |
| 29 | Screw | 74162000 | 74162000 | 74162000 | 89 | Plate f. Drawer | 71760900 | 71760900 | --- |
| 30 | Screw | 73851100 | 73851100 | 73851100 | 90 | Screw | 731612 | 731612 | --- |
| 31 | Screw | 73861300 | 73861300 | 73861300 | 91 | Distance plate, Drawer | 71761000 | 71761000 | --- |
| 32 | Washer | 791891 | 791891 | 791891 | 92 | Side plate, bottom | 447623xx | 447623xx | --- |
| 33 | Screw | 731620 | 731620 | 731620 | 93 | Rear plate, bottom | 447625xx | 447625xx | --- |
| 34 | Cover | 448120xx | 448120xx | 448120xx | 94 | Screw | 73860800 | 73860800 | --- |
| 35 | Fitting for Cover | 71813200 | 71813200 | 71813200 | 95 | Drawer Box | 71760800 | 71760800 | --- |
| 36 | Screw | 731608 | 731608 | 731608 | 96 | Top plate, bottom | 44762200 | 44762200 | --- |
| 37 | Screw | 731635 | 731635 | 731635 | 97 | Washer | 79189800 | 79189800 | --- |
| 38 | Rondelle, rear, outside | 71762100 | 71762100 | 71762100 | 98 | Screw | 73961000 | 73961000 | 73961000 |
| 39 | Distance tube | 541439 | 541439 | 541439 | 99 | Handle | 71762600 | 71762600 | 71762600 |
| 40 | Rondelle, rear, inside | 542633 | 542633 | 542633 | 100 | Screw | 73860900 | 73860900 | 73860900 |
| 41 | Screw | 73861400 | 73861400 | 73861400 | 101 | Screw | 739406 | 739406 | 739406 |
| 42 | Nut | 735006 | 735006 | 735006 | 102 | Front Grate | 54762721 | 54762721 | 54762721 |
| 43 | Screw | 791835 | 791835 | 791835 | | | | | |
| 44 | Screw | 731625 | 731625 | 731625 | | | | | |
| 45 | Washer | 736210 | 736210 | 736210 | | | | | |
| 46 | Screw | 73850800 | 73850800 | 73850800 | | | | | |
| 47 | Glass fitting | 71611361 | 1611361 | 1611361 | | | | | |
| 48 | Glass fitting | 54181361 | 54181361 | 54181361 | | | | | |
| 49 | Screw | 73861000 | 73861000 | 73861000 | | | | | |
| 50 | Baffle plate, top | 71761700 | 71761700 | 71761700 | | | | | |
| 52 | Distance tube | 54143700 | 54143700 | 54143700 | | | | | |

