

Blaze King

CLARITY 26.FS.SP

FREESTANDING DIRECT VENTED GAS ROOM HEATER with Standing Pilot (SP)

For use with natural gas (NG) or propane (LPG)

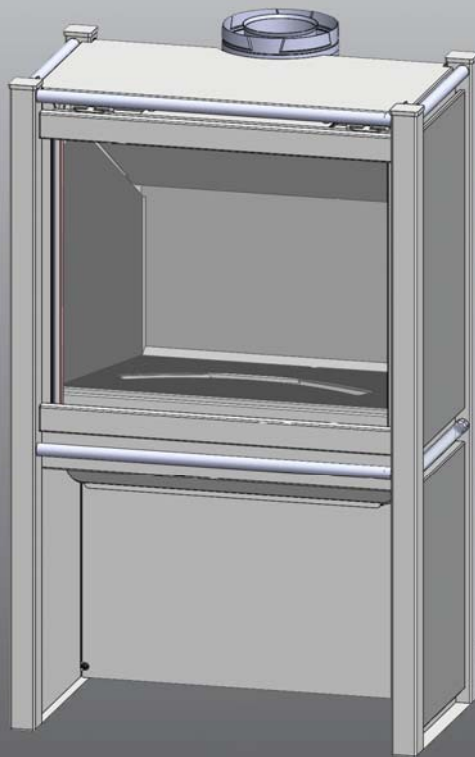

Intertek
4011009
5007099

OPERATION & INSTALLATION MANUAL

WARNING: If the information in these instructions are not followed exactly, a fire or explosion may result causing property damage, personal injury or loss of life.

Date Installed:

Serial No.:

Installer: Please complete the details on the back cover and leave this manual with the homeowner.
Homeowner: Please keep these instructions for future reference.

Pour la version française de nos manuels S.V.P. vous référez à notre site web: www.blazeking.com

SAFETY PRECAUTIONS	3
GENERAL	3
YOUR SAFETY	4
INSTALLATION	4
GENERAL INFORMATION	5
APPLIANCE CERTIFICATION	5
INSTALLATION CODES	5
SPECIFICATIONS	5
HIGH ALTITUDE INSTALLATION	5
CERTIFICATION LABEL	6
DIMENSIONS	7
LIGHTING INSTRUCTIONS	8
820 NOVA VALVE	9
OPERATING INSTRUCTIONS	10
PILOT LIGHT	10
LIGHTING THE BURNER	10
OPTIONAL BLOWER	10
MAINTENANCE and SERVICE	11
ROUTINE MAINTENANCE	11
CLEANING SURFACES	11
CLEANING THE GLASS	11
GLASS DOOR REMOVAL	12
DOOR GLASS REPLACEMENT	12
BURNER REMOVAL	13
SAFETY SCREEN REPLACEMENT	13
FUEL CONVERSION	14
INSTALLATION	16
INITIAL SETUP	16
BACKING PANEL INSTALLATION	18
PRECAUTIONS	18
VENT TERMINATION LOCATION	18
REAR VENT INSTALLATION	19
CONVERSION TO REAR VENT	19
CLEARANCE TO COMBUSTIBLES	22
GAS CONNECTIONS	23
VERTICAL VENT INSTALLATION	25
VENTING	26
VENT TERMINATION RESTRICTIONS	28
VENT RESTRICTOR	30
AIR SHUTTER ADJUSTMENT	31
BURNER FLAME APPEARANCE	31
MOBILE HOME INSTALLATION	32
ELECTRICAL REQUIREMENTS:	33
RIGID VENTING PARTS LIST	35
VALVE REMOVAL AND INSTALLATION	42
PARTS LIST	43
TROUBLESHOOTING	44
WARRANTY	45

Manufactured By

Valley Comfort Systems Inc.
1290 Commercial Way
Penticton, BC V2A 3H5
CANADA
Phone: 250-493-7444
Fax: 250-493-5833

Blaze King Industries
146 A Street
Walla Walla, WA 99362
U.S.A.
Phone: (509) 522-2730
Fax: (509) 522-9803

⚠ WARNING

FIRE OR EXPLOSION HAZARD
Failure to follow safety warnings exactly could result in serious injury, death, or property damage.

- Do not store or use gasoline or other flammable vapors and liquids in the vicinity of this or any other appliance.
- **WHAT TO DO IF YOU SMELL GAS**
 - Do not try to light any appliance.
 - Do not touch any electrical switch; do not use any phone in your building.
 - Leave the premises.
 - Immediately call your gas supplier from a neighbor's phone. Follow the gas supplier's instructions.
 - If you cannot reach your gas supplier, call the fire department.
- Installation and service must be performed by a qualified installer, service agency or the gas supplier.

This appliance may be installed in an aftermarket, permanently located, manufactured (mobile) home, where not prohibited by local codes.

This appliance is only for use with the type of gas indicated on the rating plate. This appliance is not convertible for use with other gases, unless a certified kit is used.

A barrier designed to reduce the risk of burns from the hot viewing glass is provided with this appliance and shall be installed for the protection of children and other at-risk individuals. If the barrier becomes damaged, the barrier shall be replaced with the manufacturer's barrier for this appliance.

⚠ WARNING

HOT GLASS WILL CAUSE BURNS.
DO NOT TOUCH GLASS UNTIL COOLED.
NEVER ALLOW CHILDREN TO TOUCH GLASS.

**CALIFORNIA PROPOSITION 65**

WARNING: This product can expose you to chemicals including benzene, which is known to the State of California to cause cancer and birth defects or other reproductive harm. For more information:

www.P65Warnings.ca.gov

NOTE: Failure to follow these instructions could cause a malfunction of the fireplace, which could result in death, serious bodily injury, and/or property damage.

GENERAL

- Installation and repair should be done by a qualified service person. The appliance should be inspected before the first use and, at least, annually by a qualified service person. More frequent cleaning may be required due to excessive lint from carpeting, bedding material, etc. It is imperative the control compartments, burners and circulating air passageways of the appliance be kept clean.
- If the CLARITY 26 FS is pulled out of its installation, and the vent-air intake pipes is disconnected for any reason, ensure that the vent-air intake pipes are reconnected and re-sealed in accordance to the instructions noted in INSTALLATION - VERTICAL VENT INSTALLATION or REAR VENT INSTALLATION.
- Due to high temperatures, the appliance should be located out of high traffic areas and away from furniture and draperies.
 - Children and adults should be alerted to the hazards of high surface temperatures and should stay away to avoid burn or clothing ignition.**
- Young children should be carefully supervised when in the same room as the appliance. Toddlers, young children and others may be susceptible to accidental contact burns. A physical barrier is required if there are at risk individuals in the house. To restrict access to a fireplace or stove install an adjustable safety gate to keep toddlers, young children and other at risk individuals out of the room and away from hot surfaces. Any safety screen, guard, or barrier removed for servicing an appliance must be replaced prior to operating the appliance.
- Clothing or other flammable materials should not be placed on or near the appliance.

YOUR SAFETY

- Have the venting system inspected annually by a qualified installer for blockage and signs of deterioration.
- To prevent injury, do not allow anyone who is unfamiliar with the stove to operate it.
- To prevent injury, if the pilot or pilot and burners have gone out on their own, open the glass door and wait 5 minutes to air out before attempting to relight the stove.
- Always keep the area around these appliances clear of combustible material, gasoline and other flammable liquids and vapors.
- These appliances should not be used as a drying rack for clothing or for hanging Christmas stockings/ decorations.
- Due to the paint curing on the stove, a faint odor and slight smoking will likely be noticed when the stove is first used. Open a window until the smoking stops.
- Do not use this appliance if any part has been under water. Immediately call a qualified service technician to inspect the appliance and to replace any part of the control system and any gas control which has been under water.
- Do not abuse the glass by striking it or slamming the door shut.

⚠ WARNING

DO NOT OPERATE WITH THE GLASS FRONT REMOVED, CRACKED OR BROKEN. REPLACEMENT OF THE GLASS SHOULD BE DONE BY A LICENSED OR QUALIFIED SERVICE PERSON.

INSTALLATION

- Installation and service must be performed by a qualified installer, service agency or gas supplier
- Only doors certified with the appliance shall be used. (see door part numbers in "PARTS LIST")
- This installation must conform to local codes or, in the absence of local codes, with the National Fuel Gas Code, ANSI Z223.1 / NFPA 54 in the US, or the Natural Gas and Propane Installation Code, CSA B149.1 in Canada.
- A manufactured home (USA only) or mobile home OEM installation must conform with the Manufactured Home Construction and Safety Standard, Title 24 CFR, Part 3280, or, when such a standard is not applicable, the Standard for Manufactured Home Installations, ANSI / NCSBCS A225.1, or Standard for Gas Equipped Recreational Vehicles and Mobile Housing, CSA Z240.4.
- Always connect this gas appliance to a vent system and vent to the outside of the building envelope. Never vent to another room or inside the building. Make sure the specified vent pipe is used, properly sized and of adequate height to provide sufficient draft.
- The flow of combustion and ventilation air must not be obstructed .
- The appliance and its appliance main gas valve must be disconnected from the gas supply piping system during any pressure testing of that system at test pressures in excess of 1/2 psi (3.5 kPa).
- This gas appliance must not be connected to a chimney flue serving a separate solid-fuel burning appliance.
- The appliance, when installed, must be electrically grounded in accordance with local codes or, in the absence of local codes, with the National Electrical Code, ANSI / NFPA 70, in the US, or the Canadian Electrical Code, CSA C22.1, in Canada.
- **Caution:** Label all wires prior to disconnection when servicing controls. Wiring errors can cause improper and dangerous operation. Verify proper operation after servicing.

⚠ WARNING

FAILURE TO POSITION THE PARTS IN ACCORDANCE WITH THE DIAGRAMS IN THIS BOOKLET, OR FAILURE TO USE ONLY PARTS SPECIFICALLY APPROVED WITH THIS APPLIANCE, MAY RESULT IN PROPERTY DAMAGE OR PERSONAL INJURY.

APPLIANCE CERTIFICATION

This appliance is tested and certified to the following US and Canadian gas appliance standards:

- ANSI Z21.88-2016 / CSA 2.33b-2016 Vented Gas Fireplace Heaters,
- CAN/CGA-2.17-M91(R2014) Gas-Fired Appliance for Use at High Altitudes
- CSA P.4.1-15 Testing Method for Measuring Annual Fireplace Efficiency

STEADY STATE EFFICIENCY		
Steady State Efficiency - High	Effy_{ss,H}	71.55%
Fireplace Efficiency	FE	63.69%

INSTALLATION CODES

This appliance must be installed by a qualified gas appliance installer. This appliance is certified for installation in a bedroom or a bedsitting room. This appliance is only for use with the type of gas indicated on the rating plate and may be installed in an aftermarket, permanently located, manufactured (mobile) home where not prohibited by local codes. This appliance is not convertible for use with other gases, unless a certified kit is used. Only for direct discharge without duct connection. This appliance must be direct vented using listed and approved Simpson Dura-Vent, Selkirk, Security or American Metal Products vent components.

We recommend that our gas hearth products be installed and serviced by professionals who are certified in the U.S. by the National Fireplace Institute (NFI) as NFI Gas Specialists.

**NATIONAL
FIREPLACE
INSTITUTE®**



CERTIFIED

www.nficertified.org

SPECIFICATIONS

MODEL CLARITY 26.FS.SP	Natural Gas (NG)	Propane (LPG)
Manifold Pressure	3.8 in. w.c. (0.95kPa)	10.6 in. w.c. (2.64 kPa)
Min. Supply Pressure for Purpose of Input Adjustment	7 in. w.c. (1.74 kPa)	11.0 in. w.c. (2.74 kPa)
Orifice Size	DMS #39	DMS #1.5 mm
Nominal Input Rating	27,300 BTU/hr	26,200 BTU/hr
Minimum Input Rating	14,838 BTU/hr	14,120 BTU/hr
Altitude	0 - 4,500 ft. (0 - 1372 m)	0 - 4,500 ft. (0 - 1372 m)
Primary Air Opening	50% (Minimum)	open
Electrical Rating	120 V.A.C. System	120 V.A.C. System

HIGH ALTITUDE INSTALLATION

When installing this appliance beyond 4500 ft. (1372 m) above sea level, the appliance must be properly derated and installed according to local codes, in the absence of local codes, with the current National Fuel Gas Code, ANSI Z223.1/ NFPA 54, in the US or Installation Code, CSA-B149.1, in Canada.

CERTIFICATION LABEL

Clarity 26 FS SP



Intertek
4011009
5007099

CLARITY 26 FS SP CLARITY 26 FS IPI SN - 18

Listed vented gas fireplace heater / Poêle certifié au gaz avec évacuation
 MODEL / MODELE: Clarity FS top venting appliance / Clarity FS appareil ventilé vers le haut
 This stove is factory equipped for 0-610 m (0-2000 ft) / Ce poêle est manufacturé et équipé pour 0-610 m (0-2000 pied)
 UNITED STATES AND CANADA / ÉTATS-UNIS ET LE CANADA: Certified to: CGA 2.17 ANSI Z21.88/CSA 2.33 Ed. 7. Certifié: CGA 2.17 ANSI Z21.88/CSA 2.33 Ed. 7.

Model: Clarity FS top vent appliance Modèle: Clarity FS appareil de ventilation vers le haut	<input type="checkbox"/> NATURAL GAS	<input type="checkbox"/> LP GAS
Orifice (DMS) 0-1370 m	39	1.5 mm
Input rating / Puissance d'entrée (BTU/hr / Kw) 0-1370m 0-4,500 ft Alt.	27,300 / 8.00	26,200 / 7.68
Minimum Input / Entrée Minimum (BTU/hr / Kw)	14,838 / 4.35	14,120 / 4.14
Manifold Pressure High setting / Manifold Pression réglé à High (In w.c. / kPa)	3.8 / 0.95	10.6 / 2.64
Manifold Pressure Lo setting / Manifold Pression réglé à Lo (In w.c. / kPa)	1.1 / 0.27	2.9 / 0.72
Minimum Inlet Pressure / Pression minimum d'admission (In w.c. / kPa)	7.0 / 1.74	11.0 / 2.74

This appliance must be installed in accordance with local codes, if any; if none, follow the National Fuel Gas Code, ANSI Z223.1 / NFPA 54, or the Natural Gas and Propane Installation Code, CSA B149.1.

WARNING: Improper installation, adjustment, alteration, service, or maintenance can cause injury or property damage. Refer to the owner's manual provided with this appliance. For assistance or additional information consult a qualified installer, service agency, or the gas supplier. Hot while in operation. Do not touch. Keep children, clothing, furniture, gasoline and other liquids having flammable vapors away. Keep burner and control compartment clean. See installation and operating instructions accompanying appliance.

VENTED GAS FIREPLACE HEATER —NOT FOR USE WITH SOLID FUEL

For use with glass doors certified with the appliance only. Do not operate this appliance with glass removed, cracked or broken. Replacement of the panel(s) should only be done by a qualified person. For use only with barrier Part No. 645.1821. Part No. S.Z5177.SP or S.Z5177.IPI Fan Kit may be used. Also for use in OEM / mobile(manufactured) homes after home is on site. Convertible for use with natural gas or propane as follows: For natural gas when equipped with orifice #39; For propane when equipped with orifice 1.5 mm. May be installed in a bedroom or sitting room when installed with a listed thermostat control in Canada.

Cet appareil doit être installé selon les codes locaux, s'il y en a: sinon suivez l'actuel ANSI Z223.1 / NFPA 54 ou Gaz Naturel et Propane Codes, CSA B149.1.

MISE EN GARDE: Une mauvaise installation, un ajustement, une altération, service ou entretien peuvent causer des blessures ou des dommages à la propriété. Consultez le manuel du propriétaire fourni avec cet appareil. Pour assistance ou information additionnelle, consultez un installateur qualifié, agence de service ou votre fournisseur de gaz.

Chaud lorsque l'appareil fonctionne. Ne pas toucher. Tenir loin des enfants, vêtements, meubles, essence et autres liquides ayant des vapeurs inflammables. Tenir le compartiment du brûleur et de contrôle propre. Voir les instructions de l'installation et du fonctionnement accompagnant cet appareil.

FOYER AU GAZ AVEC ÉVENT —NE PAS UTILISER AVEC DU COMBUSTIBLE SOLIDE

Utiliser seulement avec des portes vitrées certifiées pour cet appareil. Ne pas opérer cet appareil, si la vitre est manquante, craquée, ou brisée. Le remplacement des panneaux de verre seulement être fait par une personne qualifiée. À utiliser uniquement avec le numéro de pièce de barrière 645.1821. Numéro de pièce fan S.Z5177.SP ou S.Z5177.IPI ou Ensemble Ventilateur peuvent être utilisés. Aussi pour l'usage dans les maisons mobiles (manufacturées) après que la maison soit installée sur le site. Pouvant être converti pour usage avec le gaz naturel ou le propane comme suit: Pour le gaz naturel une fois équipé d'un orifice # 39.; Pour le propane une fois équipé de l'orifice # 1.5 mm. Peut être installé dans une chambre à coucher ou un salon une fois installé avec un thermostat approuvé au Canada.

MINIMUM CLEARANCES TO COMBUSTIBLES / DÉGAGEMENTS MINIMUM REQUIS ENTRE L'APPAREIL ET DES MATÉRIEAUX COMBUSTIBLES	
A Unit to sidewall / Unité au mur latéral	2" (51 mm)
B Unit to back wall / Unité à au mur arrière	2.5" (64 mm)
C Unit corner to sidewall / Unité en coin au mur	2" (51 mm)
D Unit to top / Unité jusqu'au haut	33" (838 mm)
E Alcove width / alcôve largeur	27.875" (708 mm)
F Alcove height / alcôve hauteur	70.5" (1791 mm)
G Vent / évacuation de surface extérieure	4" (25 mm) from outside surface* * 2" (51 mm) horizontal vent to combustible

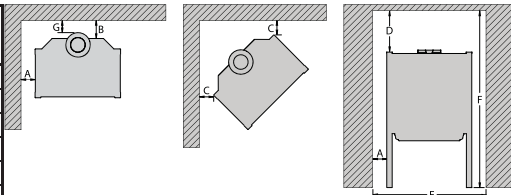

NOTE: CHECK LOCAL CODES FOR FLOOR REQUIREMENTS. THIS FIREPLACE IS SUITABLE FOR INSTALLATION ON A COMBUSTIBLE SURFACE. VÉRIFIER LES CODES LOCAUX POUR ÉQUIPEMENT DE SURFACE DE PLANCHER, CET APPAREIL PEUT ÊTRE INSTALLÉ SUR UNE SURFACE COMBUSTIBLE

Electrical Rating: 115 Volts, 0.7 Amp, 60 Hz for S.CL26.FS.IPI and S.Z5177.SP Fan Kit.

DANGER: Risk of electrical shock. Disconnect power before servicing unit. Do not route power cord beneath heater. This appliance must be installed in accordance with the Standard CAN/CSA Z240 MH, Mobile Housing, in Canada, or with the Manufactured Home Construction and Safety Standard, Title 24CFR, Part 3280, in the United States, or when such a standard is not applicable, ANSI / NCSBCSA 225.1 / NFPA501A, Manufactured Home Installations Standard. This appliance is only for use with the type of gas indicated on the rating plate and may be installed in an aftermarket, permanently located, manufactured(mobile) home where not prohibited by local codes. See owners manual for details. This appliance is not convertible for use with other gases unless a certified kit is used. This vented gas fireplace is not for use with air filters.

Caractéristiques électriques: 115 Volts, 0.7 Amp, 60 Hz pour S.CL26.FS.IPI et S.Z5177.SP Ensemble Ventilateur.

DANGER: Risque d'électrocution. Débrancher le courant avant de réparer l'unité. Ne pas mettre le cordon d'alimentation en dessous de l'appareil de chauffage. Cet appareil doit être installé selon les codes CAN/CSA Z240 MH, maisons mobiles (manufacturées), au Canada, sinon applicable, utilisez ANSI / NCSBCS A225.1/NFPA 501 A, Installation d'une maison mobile standard.

Cet appareil peut être utilisé seulement avec le type de gaz indiqué sur la plaque de contrôle et peut être installé dans un marché des accessoires, maison (mobile) de manière permanente placée et manufacturée où ils ne sont pas interdit par des codes. Voir le manuel d'installation pour des détails. Cet appareil ne peut pas être converti pour l'usage avec d'autres gaz à moins qu'un kit de conversion certifié soit employé. Ce foyer au gaz à évacuation ne pas être utilisé avec des filtres à air.

MANUFACTURE DATE

MANUFACTURED IN:

USA: Blaze King Industries
146A Street, Walla Walla, WA. 99362

CANADA: Valley Comfort Systems
1290 Commercial Way, Penticton, B.C. V2A 3H5

JAN FEB MAR APR MAY JUN
 JUL AUG SEP OCT NOV DEC
 2017 2018 2019 2020 2021 2022
 170.0231[0717].indd

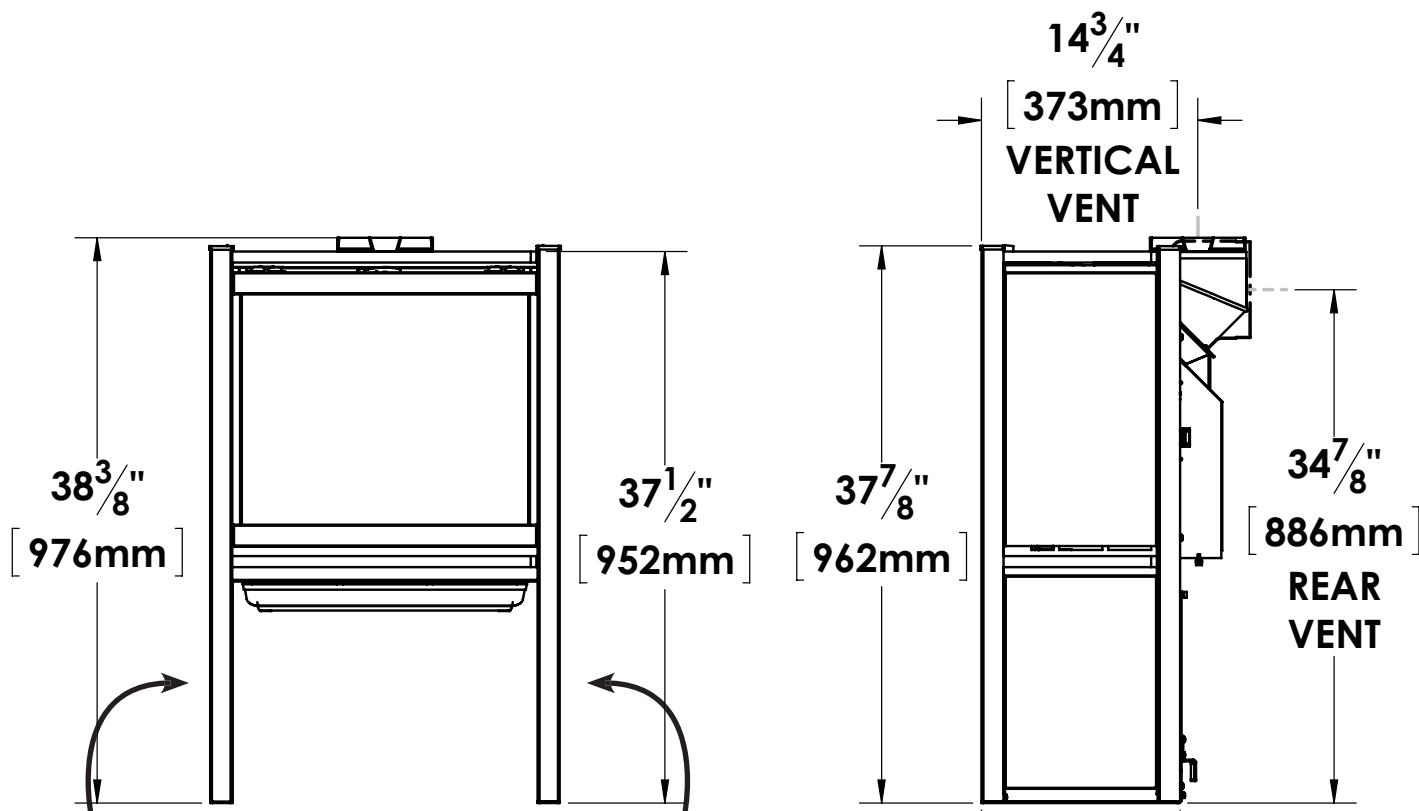

NOTE: RATING AND LIGHTING INSTRUCTION LABELS ARE LOCATED ON THE LOWER RIGHT AND LEFT OUTSIDE PANELS. TO REMOVE, LIFT UP AND OFF.

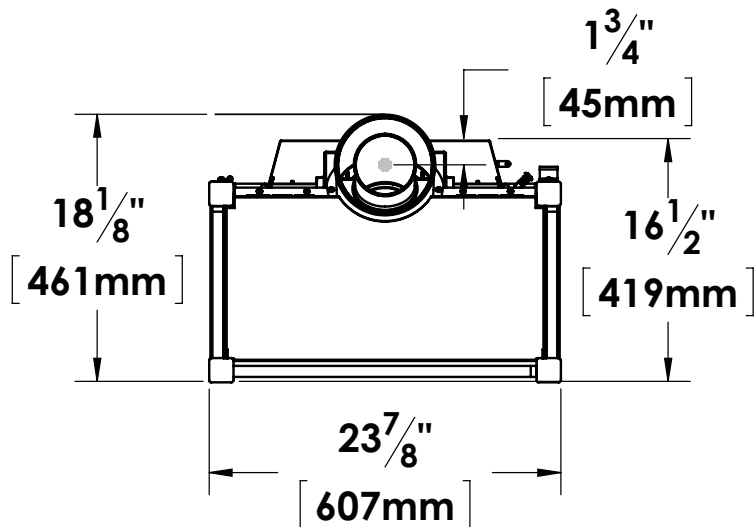

NOTE: TURNING ON YOUR APPLIANCE WHEN IT HAS BEEN OFF FOR AWHILE MAY CAUSE CONDENSATION TO APPEAR ON THE GLASS. THIS IS A NORMAL OCCURRENCE AS YOUR APPLIANCE HEATS UP.



NOTE: THIS FIREPLACE IS SUITABLE FOR INSTALLATION ON A COMBUSTIBLE SURFACE. MAY BE INSTALLED ON CARPET.

FOR YOUR SAFETY, READ BEFORE LIGHTING

WARNING: If you do not follow these instructions exactly, a fire or explosion may result causing property damage, personal injury or loss of life.

- A. This appliance has a pilot which is lit with a push button piezo lighter. When lighting the pilot, follow these instructions exactly.
- B. BEFORE LIGHTING, smell all around the appliance area for gas. Be sure to smell next to the floor because some gas is heavier than air and will settle on the floor.
WHAT TO DO IF YOU SMELL GAS:
 - Do not try to light any appliance.
 - Do not touch any electric switch; do not use any phone in your building.
 - Immediately call your gas supplier from a neighbor's phone. Follow the gas suppliers instructions.
 - If you cannot reach your gas supplier, call the fire department.
- C. Use only your hand to push in or turn the gas control knob. Never use tools. If the knob will not push in or turn by hand, don't try to repair it, call a qualified service technician. Force or attempted repair may result in a fire or explosion.
- D. Do not use this appliance if any part has been under water. Immediately call a qualified service technician to inspect the appliance and to replace any part of the control system and any gas control which has been under water.

LIGHTING INSTRUCTIONS

1. STOP! Read the safety information above.
2. Set the thermostat to the lowest setting.
3. Valve controls are accessed by lowering the hinged panel that is below the firebox.
4. Set the manual burner switch(back right-hand side of the appliance) to the "OFF" position.
5. Push in gas control knob slightly and turn clockwise  to "OFF".
6. Wait five (5) minutes to clear out any gas. Then smell for gas, including near the floor. If you smell gas, STOP! Follow "B" in the safety information above. If you don't smell gas, go to the next step.
7. Turn control knob counterclockwise  to "PILOT" position.
8. Depress control knob and push in Piezo ignitor button. Once pilot ignites, continue to hold the control knob in for about one (1) minute after the pilot is lit. Release knob and it will pop back up. Pilot should remain lit. If it goes out, repeat steps 6 through 8.
 - If knob does not pop up when released, stop and immediately call your service technician or gas supplier.
 - If the pilot will not stay lit after several tries, turn the gas control knob to "OFF" and call your service technician or gas supplier.
9. Turn gas control knob counter clockwise  to "ON". Turn on all electric power to the appliance. Set thermostat to the desired setting or set the manual burner switch to the "ON" position.

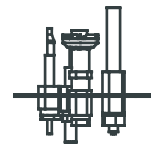

TO TURN OFF GAS TO THE APPLIANCE

1. Set the thermostat to the lowest setting.
2. Turn off all electric power to the appliance if service is to be performed.
3. Push in gas control knob slightly and turn clockwise  to "OFF". Do not force.

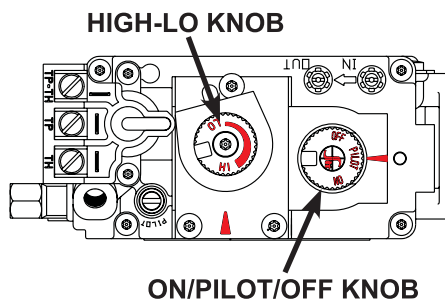

HIGH-LO KNOB

ON/PILOT/OFF KNOB

WARNING

Improper installation, adjustment, alteration, service or maintenance can cause injury or property damage. Refer to the owner's information manual provided with this appliance. For assistance or additional information, consult a qualified installer, service agency or your gas supplier.

170-0362[0318].indd

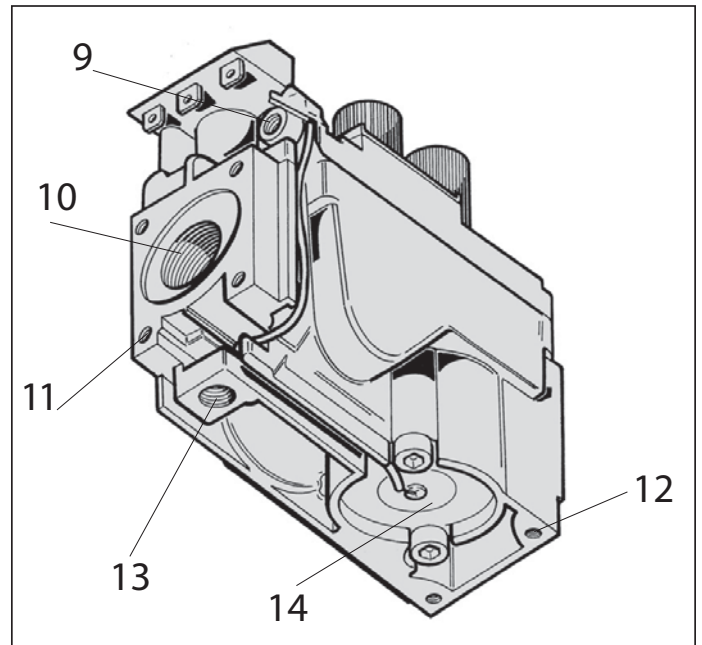
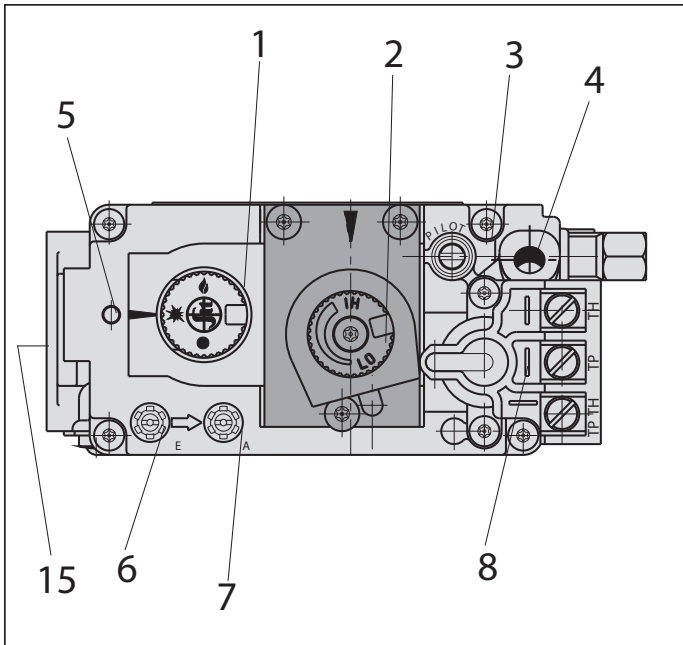

820 NOVA VALVE	
1	ON/PILOT/OFF Knob
2	Manual HI-LO adjustment or pressure regulator adjustment
3	Pilot adjustment
4	Thermocouple connection
5	Mounting for piezo & bracket
6	Inlet pressure test point
7	Outlet pressure test point
8	Main operator
9	Pilot outlet
10	Main gas outlet
11	Flange mounting screw holes
12	Additional valve mounting holes
13	Alternative TC connection point
14	Thermoelectric unit
15	Inlet

PILOT LIGHT

Refer to the lighting instruction label on how to light the pilot. Check that the pilot has fully engulfed the thermocouple assembly (**Fig.1**).

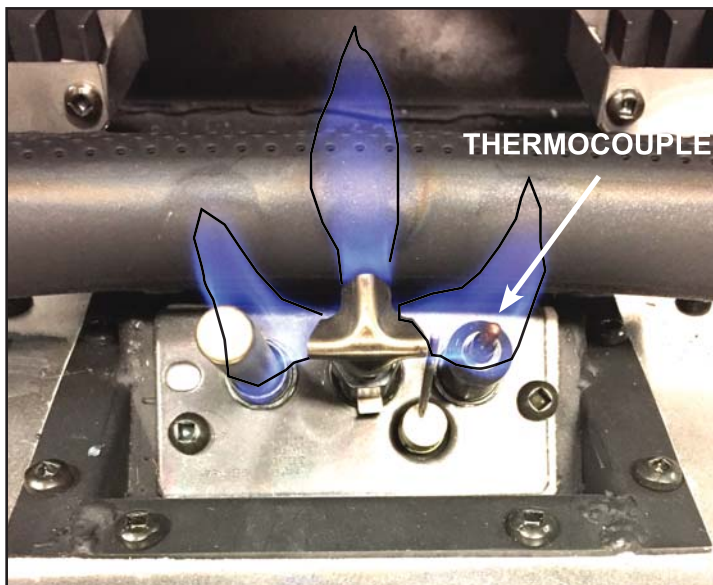



Fig.1

LIGHTING THE BURNER**Standing Pilot (SP)**

The CLARITY 26 FS SP controls are located behind the hinged door beneath the firebox. (**Fig.2**) To light the burner follow the steps below:

1. Make sure the pilot is lit (see "LIGHTING INSTRUCTIONS Standing Pilot")
2. Turn the "Valve Control" knob counterclockwise  to ON.
3. Flip the flame ON/OFF switch, located on the back of the rear shield to ON. (**Fig.3**)
4. Turn the "Flame Height" knob to the desired flame height. (**Fig.2**)
5. Turn on all electrical power to the unit.
6. **NOTE:** Burn the appliance on high, with the optional blower OFF, for the first two to three hours. This will cure all the paint, gasket, and seals. It is advised to open a door or window as the unit will smoke and give off odors as it is curing.

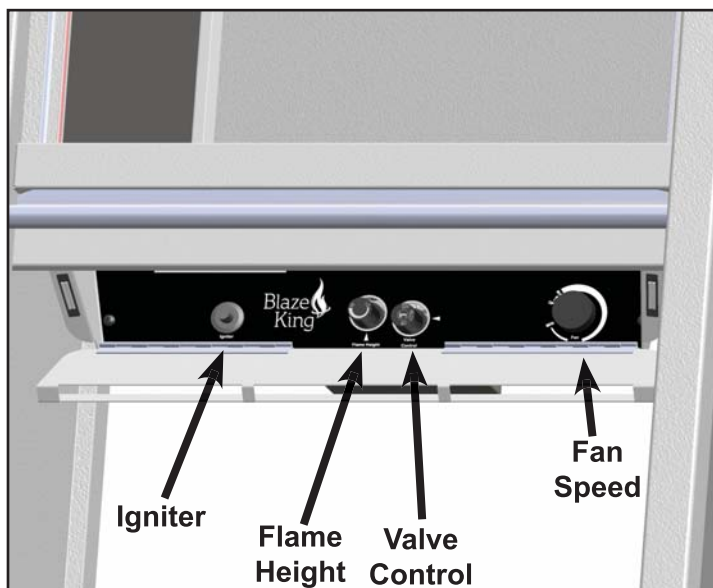

Fig.2

OPTIONAL BLOWER

An optional blower is available for the CLARITY 26 FS SP and CLARITY 26 FS IPI, the S.5177.SP and S.5177.IPI blower kits respectively. For installation refer to the installation instructions provided with the kit.





Turn the blower on by turning the "Fan speed" knob clockwise . (**Fig.2**) The blower will only come on when the fireplace is up to temperature (approximately 10-15 minutes). Fan speed control sequence is off, then maximum to minimum. The speed of the fan can be decreased by turning the knob clockwise . The speed of the fan can be increased by turning the knob counterclockwise . The blower will continue to operate after the burner is turned off (approximately 15-20 minutes). To turn the blower off manually, turn the fan control knob counterclockwise  until it "clicks".

Fig.3



ROUTINE MAINTENANCE**Regularly:**

- Clean and remove any lint accumulations or debris from the grills and combustion or convection air passage ways.
- Keep the appliance area free from combustible materials, such as paper, wood, clothing, gasoline, flammable solids, liquids and vapors.
- Visually check the height and color of the burner and pilot flames. The pilot flame should be blue with little or no yellow on the tips.
- Check for unusual noises or odors during operation of the appliance.
- Check the vent terminal for any damage, or obstruction by plants or debris accumulation.

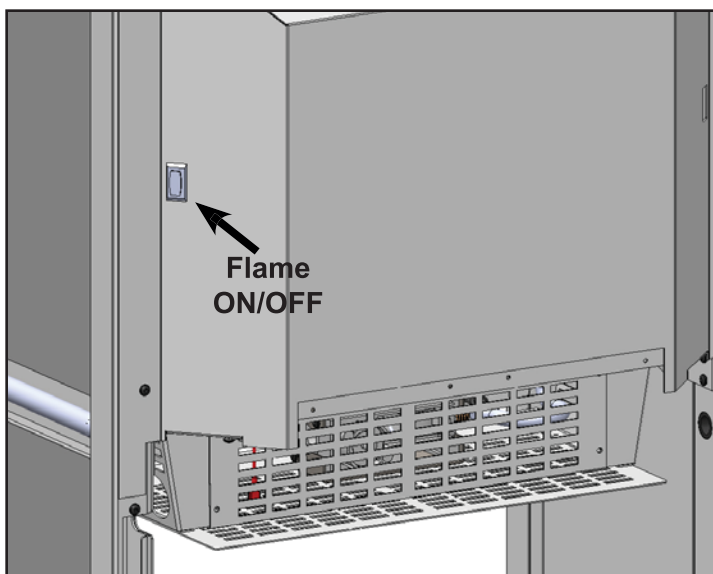
It is recommended to periodically have your appliance serviced by a qualified service technician:

1. Remove the glass door (see “**GLASS DOOR REMOVAL**” on next page) and clean the inside of the glass with a soft, non-abrasive cloth and water or a suitable, mild, non-abrasive cleaner.
2. Remove and clean the glass floor panel and set aside.
3. Remove and clean the floor panel assembly, check the burner to see if all the ports are clear and clean. Check the pilot assembly to make sure it is not blocked by anything.
4. Completely inspect the appliance and the venting system.
5. Check the safety system of the gas valve.

CLEANING SURFACES

Painted, powder coated, or porcelain enameled surfaces should be wiped with a damp cloth periodically. Ensure the appliance has cooled down completely before any cleaning. Do not use other cleaners as they may leave a residue which can become permanently etched into the surface.

CLEANING THE GLASS**⚠ WARNING****DO NOT TO CLEAN THE GLASS WHILE IT IS HOT**

One of the by-products of combustion and moisture in the firebox is a white film which can show up on the glass of the viewing door. Initial curing of the appliance can also leave a slight film on the glass, which is a temporary problem.

1. Turn off the appliance and allow it to cool down completely.
2. Remove the glass door from the firebox (see “**GLASS DOOR REMOVAL**” on next page)
3. Check the gasket material on the back of the glass. Ensure that it is attached and intact.
4. Clean the glass with a mild glass cleaner and a soft cloth (see below). Abrasive cleaners will damage the glass

Slight soiling of SCHOTT ROBAX® panels can be removed using conventional glass cleaning products, provided they are used according to instructions of use, which means cleaning on cold surfaces. The residues should be removed since chemical attack is possible on exposure to temperature. The coated ROBAX® Mirror, ROBAX® TrueView, ROBAX® IR Max and ROBAX® Energy Plus can be cleaned with a soft cloth.

NOTE: IT IS NOT RECOMMENDED TO USE SCOURING PADS, ABRASIVE CLEANSERS OR SCOURING AGENTS, AS MAY CAUSE DAMAGE TO THE GLASS SURFACE. THE SCHOTT-RECOMMENDED DRY WIPER IS SUITABLE FOR USE ONLY ON UNCOATED FIRE VIEWING PANELS.

GLASS DOOR REMOVAL

For installation, cleaning, and burner removal the glass door must be removed.

1. Turn off the appliance and allow it to cool down completely.
2. Remove the top lid assembly from the top of the appliance and set it aside. **(Fig.4)**
3. There are two door latch mechanisms on top of the glass door. **(Fig.4)** Pull the tabs forward and up off the door tabs.
4. Carefully slide the door glass assembly up and out of the unit. **(Fig.5)**

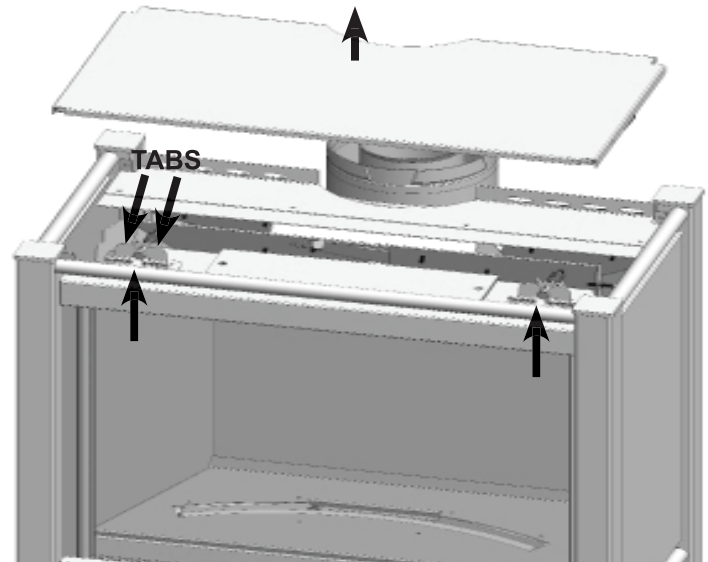
**Fig.4****DOOR GLASS REPLACEMENT**

This glass in this appliance is a 5 mm high temperature anti-reflective ceramic glass that will easily withstand the heat that is produced. In the event the glass breaks or cracks, contact your dealer to arrange for your glass to be replaced with a factory replacement (see **"PARTS LIST"**). Do not operate this appliance with the glass front removed, cracked, or broken. Removal and replacement of the glass from the door must be done by a qualified service technician. The glass must be purchased from a Blaze King dealer. No substitute materials are allowed.

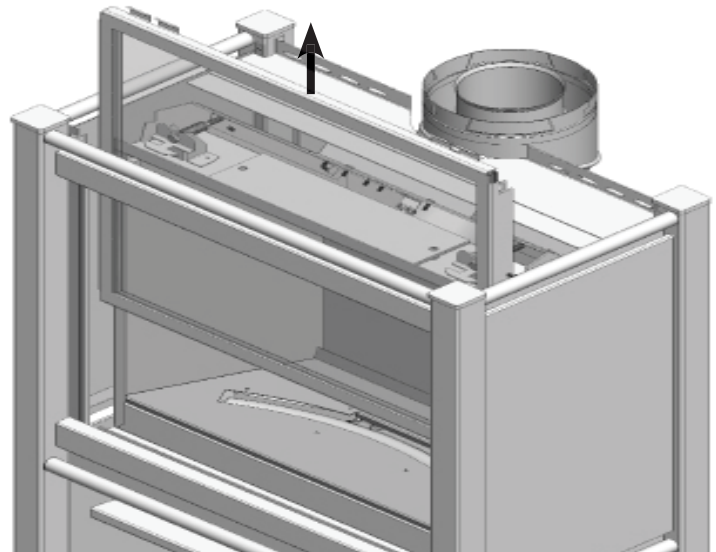
**Fig.5**

BURNER REMOVAL

1. Turn off the appliance and allow it to cool down completely.
2. Remove the glass door and safety screen (see “**GLASS DOOR REMOVAL**” on previous page and “**SAFETY SCREEN REMOVAL**” below)
3. Remove the glass floor plate and set it aside. (**Fig.6**)
4. Remove the floor plate assembly and set it aside. (**Fig.6**)
5. Remove the screw from the left hand side of the burner assembly. (**Fig.6**)
6. Move the burner to the right, up, and out.

To re-install the burner follow steps 1 to 7 in reverse. Ensure the burner is centered in the curved burner slot of the floor plate.

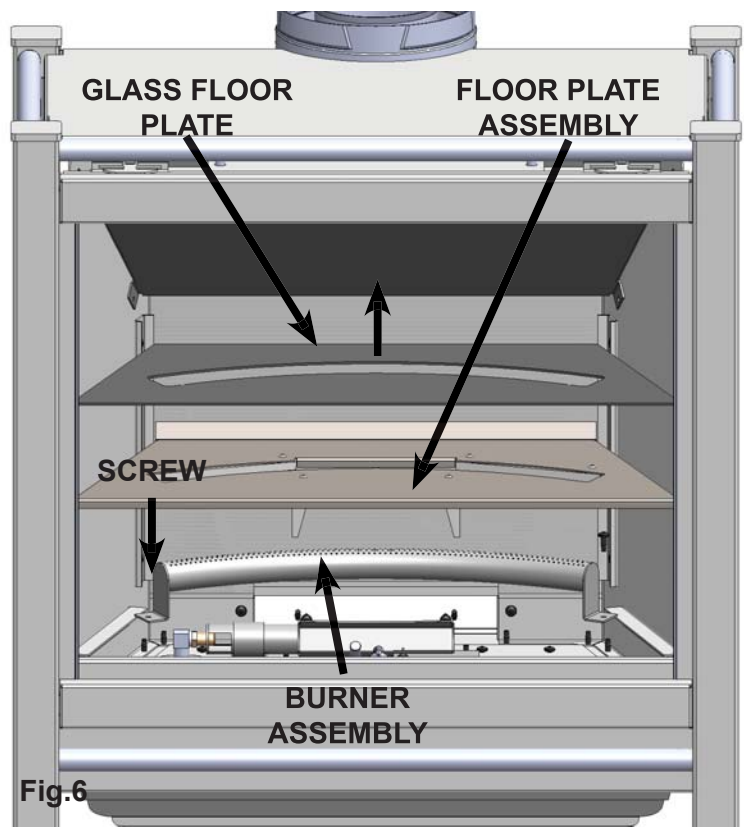

Fig.6

SAFETY SCREEN REPLACEMENT

The CLARITY 26 FS is supplied with a safety screen pre-installed behind the front legs. If the safety screen becomes damaged it must be replaced with part #645.1821

1. Turn off the appliance and allow it to cool down completely.
2. Remove the top lid assembly from the top of the appliance and set it aside. (**Fig.7**)
3. Slide the safety screen up and out.
4. Slide the new safety screen in between the front legs and the brackets. Ensure screen mesh faces out, furthest from glass.
5. Place the top lid assembly back into position.

SCREEN MESH TO THIS SIDE

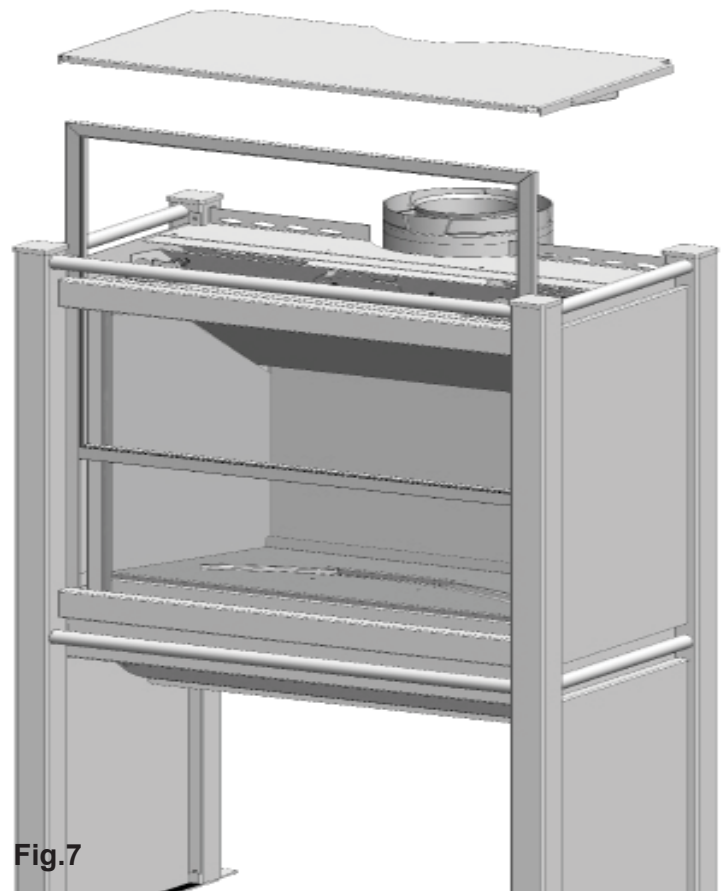
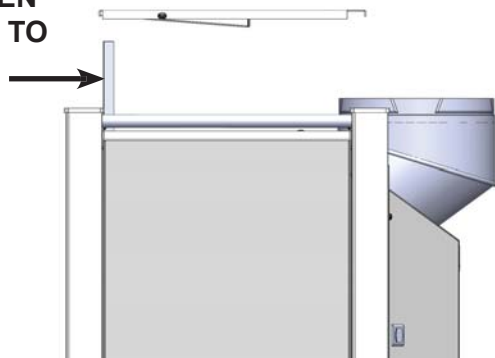

Fig.7

FUEL CONVERSION**⚠ WARNING**

THIS CONVERSION KIT SHALL BE INSTALLED BY A QUALIFIED SERVICE AGENCY IN ACCORDANCE WITH THE MANUFACTURER'S INSTRUCTIONS AND ALL APPLICABLE CODES AND REQUIREMENTS OF THE AUTHORITIES HAVING JURISDICTION. IF THE INFORMATION IN THESE INSTRUCTIONS IS NOT FOLLOWED EXACTLY, A FIRE, EXPLOSION OR PRODUCTION OF CARBON MONOXIDE MAY RESULT CAUSING PROPERTY DAMAGE, PERSONAL INJURY OR LOSS OF LIFE. THE QUALIFIED SERVICE AGENCY IS RESPONSIBLE FOR THE PROPER INSTALLATION OF THE KIT. THE INSTALLATION IS NOT COMPLETE UNTIL THE OPERATION OF THE CONVERTED APPLIANCE IS CHECKED AS SPECIFIED IN THE INSTRUCTION MANUAL SUPPLIED WITH THE KIT. BEFORE PERFORMING THIS OR ANY SERVICE PROCEDURE, MAKE SURE THAT THE GAS SUPPLY TO THE UNIT AND THE ELECTRICAL SUPPLY ARE SHUT OFF.

CONVERSION KIT CONTENTS

The conversion kit contains the following parts:

- S.Z0760 (LPG)> #635.OR1.5 (1.5 mm orifice) and LPG regulator.
- S.Z0761 (NG)> #635.OR39 (#39 orifice) and NG regulator.
- Conversion Kit labels.

To convert from NG to LPG or reverse:

1. Turn off the appliance and allow it to cool down completely
2. Remove burner (see **"BURNER REMOVAL"** on previous page)
3. Replace main orifice
4. Convert pilot fuel (see below)
5. Replace regulator (see next page)

How to convert CLARITY 26 FS SP Pilot orifice:

1. Use a 7/16" wrench to loosen the pilot hood.
2. Push the little tab in and the little tab with hole should pop out. The hole stamp tab (LP) out is used for Propane. The stamped tab (NA) out is for Natural Gas.
3. Re-tighten the pilot hood.
4. Fill out the fuel conversion label and affix between the two labels on the control panel door.

All valves have been pre-set and certified for installation at elevations from 0 – 4500 feet (1 – 1372m) above sea level.

HIGH ELEVATIONS

When installing this unit at higher elevations, it is necessary to decrease the input rating by replacing the existing burner orifice with a smaller size for installations over 4500 feet (1370 m). Above 4500 ft, the appliance input should be reduced 4% for each additional 1000 feet (305m). For the USA, derate the unit according to the gas installation code.

installation instructions

7.252.021 001

820 NOVA

HI/LO Conversion Kit



WARNING!

The installation of this conversion kit must only be undertaken by a qualified and certified gas appliance installer.

This installation or replacement instruction refer to HI-LO pressure regulator kit to be used to convert the 820 Nova Combination Gas Control with adjustable pressure regulator into manual HI-LO. The same kit can also be used for the conversion from LP to Natural Gas and vice versa of the 820 Nova with manual HI-LO.

- 1 Turn control knob to the OFF position, and shut off the gas supply to the valve.
- 2 Using a Torx T20, or slotted screwdriver, remove and discard the three pressure regulator mounting screws (A), pressure regulator tower (B), and the spring and diaphragm assembly (C).
- 3 Ensure the rubber gasket (D), which is prefitted as part of assembly (E), is properly positioned and install the new HI/LO pressure regulator assemble using the supplied screws (F). Tighten screws securely. (Reference torque = 25 lb-in).
- 4 Install the enclosed identification label (G) to the valve body where it can be easily seen.
- 5 Apply gas to system and re-light appliance according to manufacturers instructions.
- 6 With the main burner "ON", test the new pressure regulator assembly for leaks using a soap solution.
- 7 Relight the main burner in both the HI, and LO positions, and verify proper burner ignition and operation.

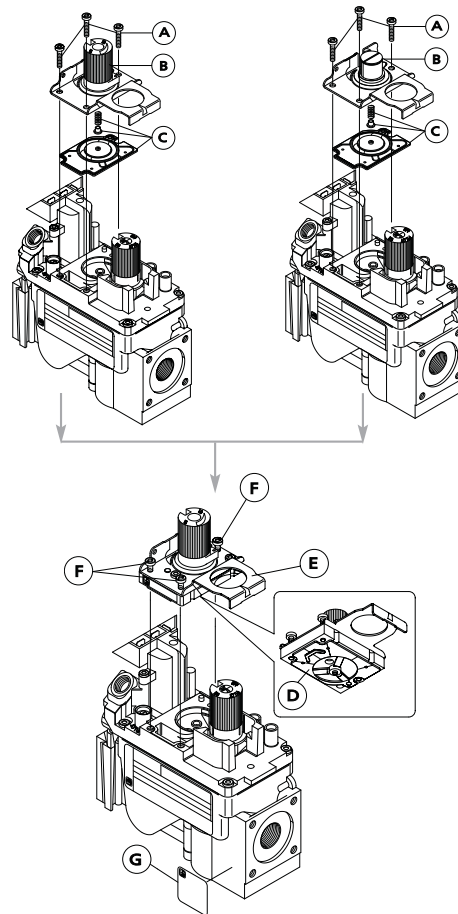

WARNING!

This HI-LO conversion kit must ONLY be applied as part of a conversion kit supplied by the APPLIANCE MANUFACTURER for the specific appliance, and type of gas, being converted.

INSTALLER NOTICE. These instructions must be left with appliance.



SITGroup

This section of the owner's manual is for the use of qualified service technicians only. Fireplace placement, hearths, and venting terminations will be covered, as well as the gas and electrical systems. Please read "SAFETY PRECAUTIONS" at the front of this manual.

INITIAL SETUP

1. Remove the top lid assembly from appliance and set it aside.
2. There are two door latch mechanisms on the top of the glass door.(Fig.8) Pull the tabs forward and up off the door tabs.
3. Carefully slide the door glass assembly up and out of the appliance(Fig.9). **NOTE: REMOVE THE STATIC CLING LABEL THAT IS ON THE DOOR GLASS.** Hold glass to frame when removing as it is only held in place with silicone. Set the door aside.
4. Slide the safety screen up and out from appliance and set aside.(Fig.10)
5. Remove packaged contents from firebox and unwrap, one package contains the floor glass, the other contains the side panels. **HANDLE GLASS CAREFULLY BY THE EDGES, DO NOT LEAVE FINGERPRINTS, CLEAN IF NECESSARY.** Set glass panels aside in a safe place.
6. Remove floor plate assembly from appliance and set aside. (Fig.11)

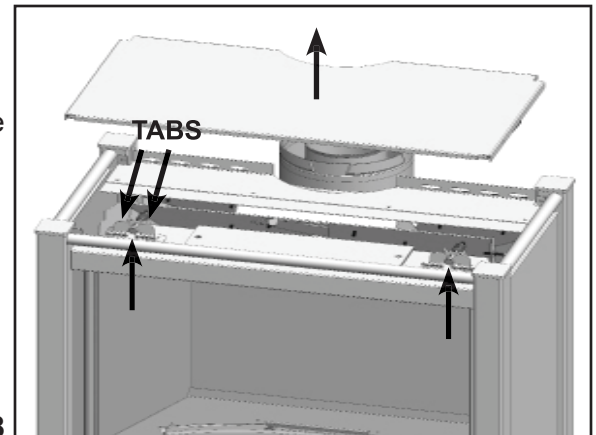

Fig.8

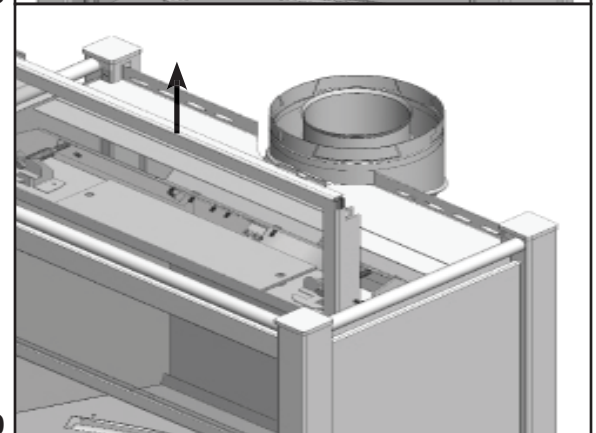

Fig.9

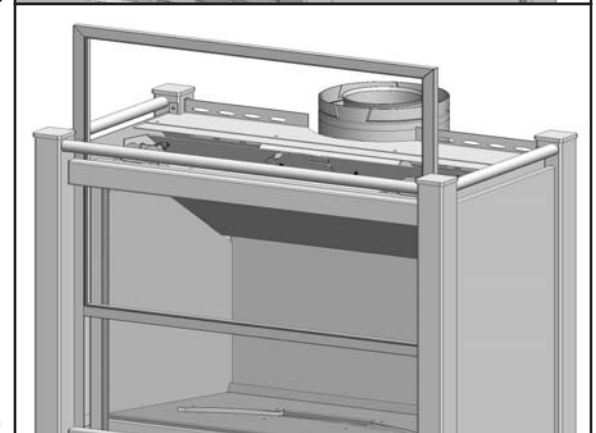

Fig.10

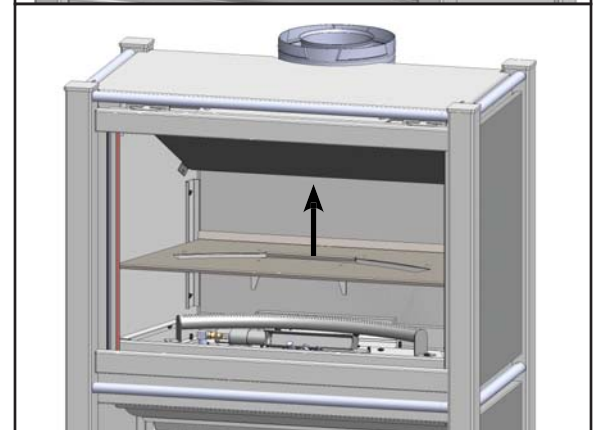

Fig.11

7. Loosen the top left tab as shown by arrow, install the left glass up under the tab and onto the support. (Fig.12) **NOTE: THE SIDE WITH LABEL SHOULD BE FACING FIREBOX, REMOVE BEFORE FIRING. HANDLE GLASS CAREFULLY BY THE EDGES, DO NOT LEAVE FINGERPRINTS, CLEAN IF NECESSARY**

8. Repeat Step 7 for the right side panel.

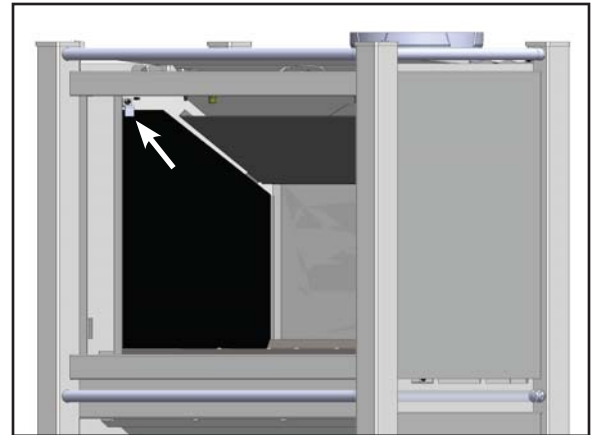

Fig.12

9. Carefully place the floor plate assembly back into position (Fig.13).

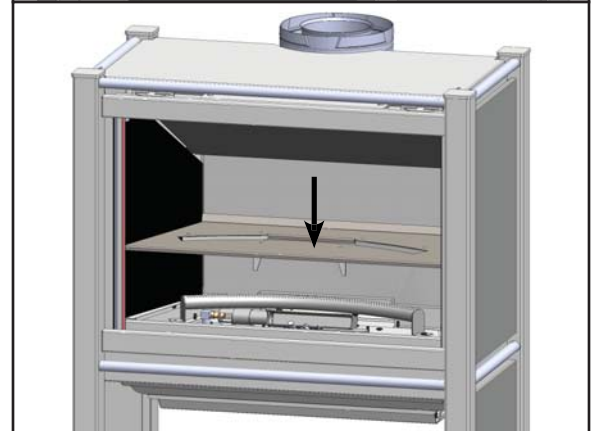

Fig.13

10. Place the floor glass on top of the floor plate assembly. (Fig.14) **NOTE: SMOOTH SIDE SHOULD FACE UP.**

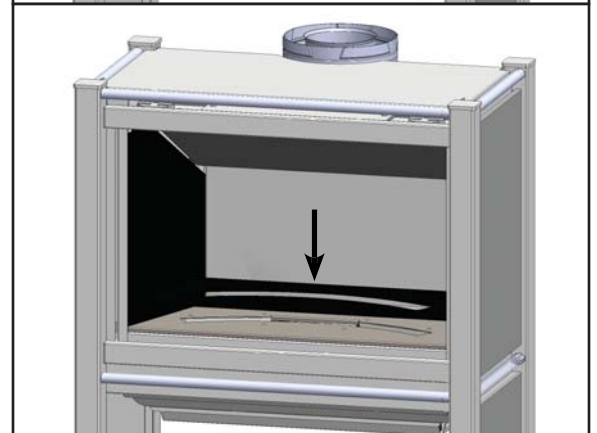

Fig.14

11. If installing the optional log set (Fig.15) refer to installation instructions on Page 35, if not continue below.

12. Repeat steps 1 to 4 in reverse order to complete initial setup.

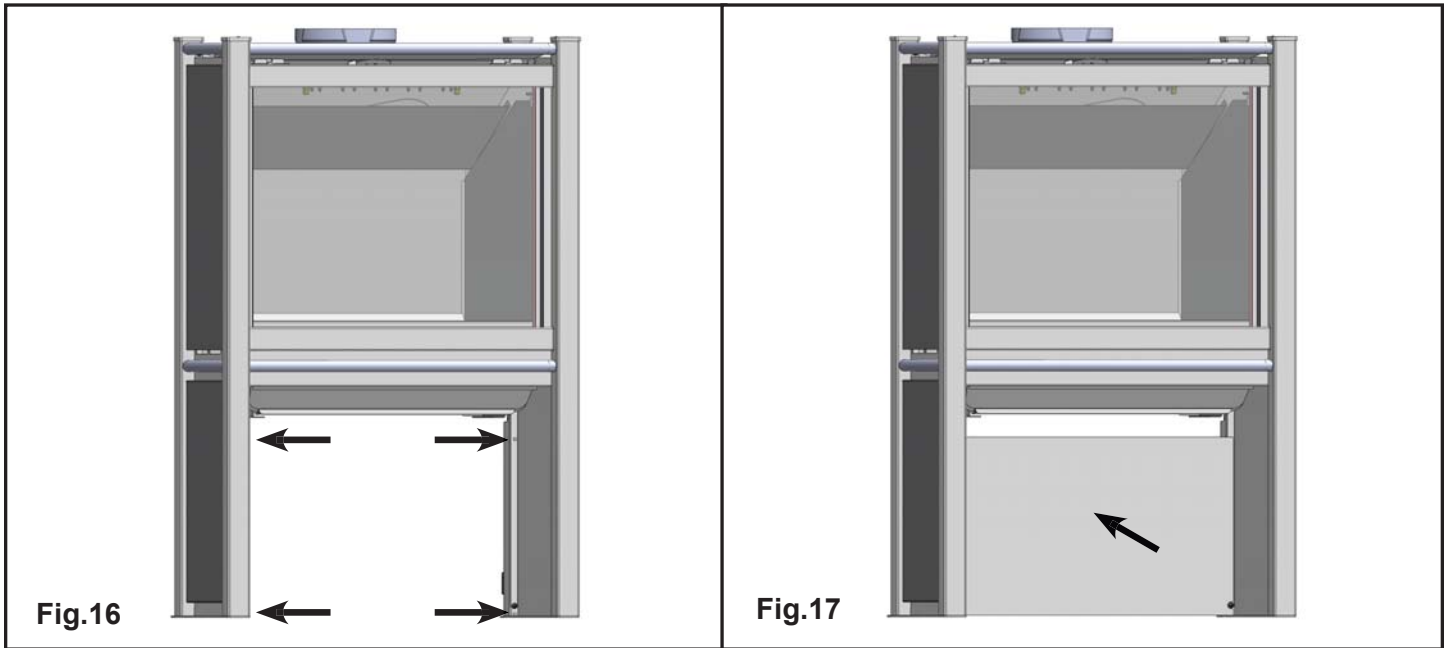

Fig.15

BACKING PANEL INSTALLATION

There is a supplied backing panel that can be used to hide gas lines, power cords etc.

- There are four magnets in the manual bag, attach the magnets as shown in (Fig.16) to the back legs of the appliance.
- Place the backing panel onto the magnets as shown in (Fig.17), with the notches on the bottom.



PRECAUTIONS

- The installation must conform to the installation codes.
- This appliance needs fresh air for safe operation and must be installed so there are provisions for adequate ventilation air. Provide adequate clearance around air openings of the appliance. Never obstruct front openings.
- Provide adequate clearances for proper operation and servicing of the appliance.
- This appliance must be properly connected to a venting system.
- The venting of this appliance must be installed in a location that is free of plumbing, electrical wiring and heating or air conditioning ducts.
- Select a location that is accessible for venting.(see “**VENT TERMINATION LOCATIONS**”)

VENT TERMINATION LOCATION

- Establish a suitable vent termination location (see “**VENT TERMINATION LOCATIONS**”)
- In heavy snowfall areas make sure vent termination is located where it will not be blocked by snowfall or snow from snow removal equipment.
- Locate vent termination away from plants, bushes, or any other object on or near the vent termination that will interfere or obstruct the air flow around it.
- DO NOT recess vent termination into walls, sidings, or planters.
- Vent terminations located below 7 ft (2130 mm) from grade level or anywhere that it is a burn hazard to the public, such as patios and balconies, must be protected with an approved termination cage.

REAR VENT INSTALLATION

Two snorkels are available that can be used in a rear vent application on the CLARITY 26 FS. One is the M&G Duravent 46DVA-H2-SNK36 (**Fig.18**), and the other is the Selkirk 4DT-ST36 (**Fig.19**).

Snorkel H2 Termination Cap

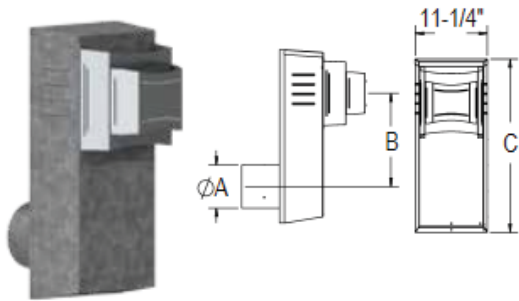

Use for horizontal through-the-wall termination when a vertical rise is desired in the system to meet appliance manufacturer recommended minimum heights. Do not enclose in the wall or install below grade. Provides improved performance in high wind conditions. Features an adjustable air intake and interchangeable shroud (shroud is included and required for all installations). Check with appliance manufacturer for approval and air throttle setting. Patent Pending.

SIZE	ORDER #	STOCK #	A	B	C
4" x 6 5/8"	46DVA-H2-SNK36	810012916	6 3/4"	37"	49 1/2"

Fig.18

SNORKEL TERMINATION

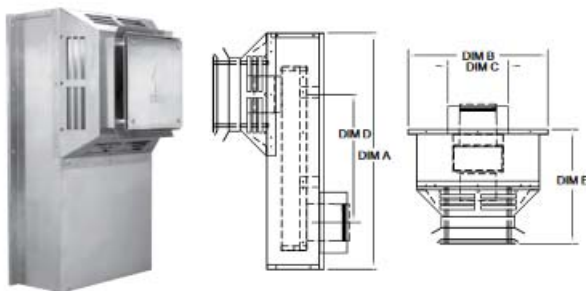

- Use when horizontal termination is too close to grade or additional height is needed

Size	Description	Part #	Sku #
4 x 6 5/8"	36" Rise Snorkel Termination 4 x 6-5/8"	4DT-ST36	1604838

SNORKEL SIZE	DIM A	DIM B	DIM C	DIM D	DIM E
36.0"	48.0"	15.25"	6.63"	36.0"	13.25"

Fig.19

CONVERSION TO REAR VENT

1. Remove the top assembly from the appliance and set aside. (**Fig.20**)

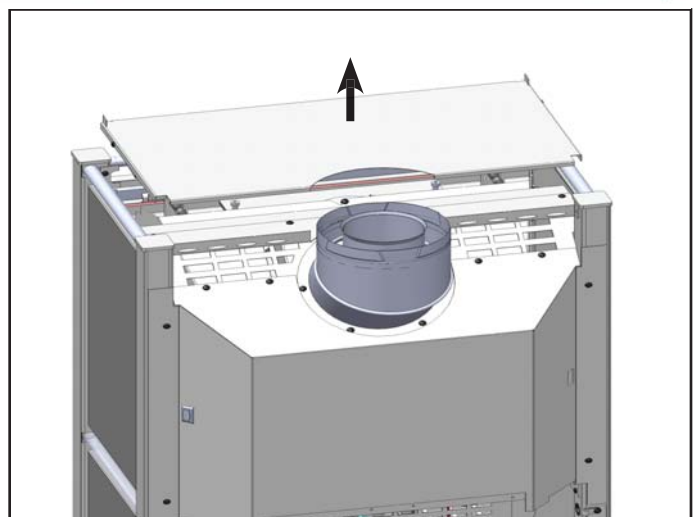

Fig.20

2. Remove screws from top rear grill assembly (1 screw each side of leg, two screws each side of flue collar). (Fig.21)

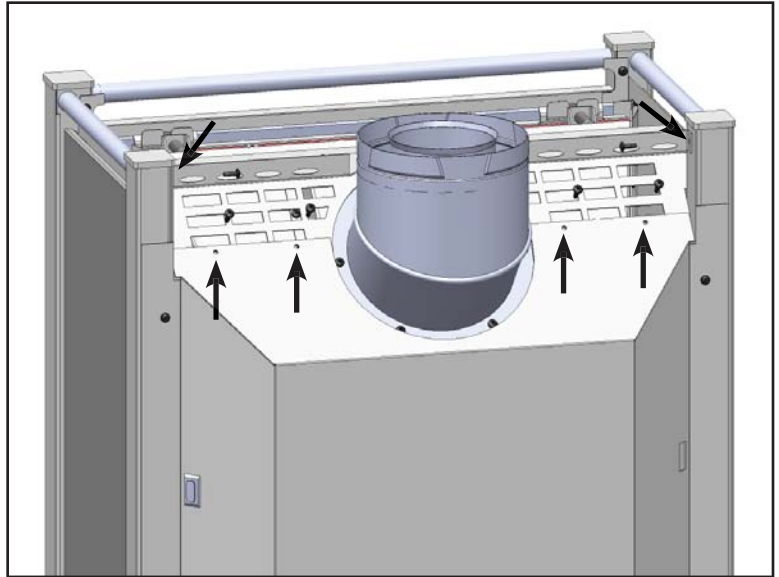

Fig.21

3. Remove top rear grill assembly from appliance and set aside. (Fig.22)

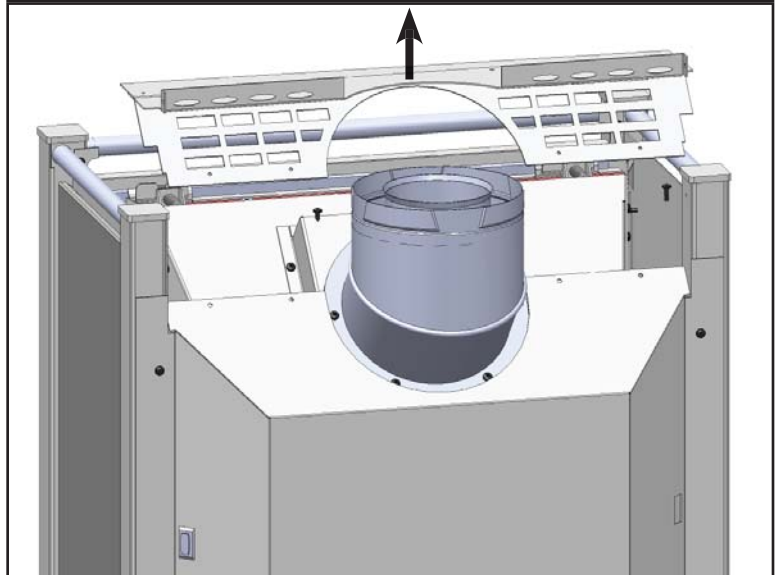

Fig.22

4. Unscrew outer rear shield from appliance (9 screws). Be sure to undo wire clamp before attempting to remove the shield. (Fig.23)

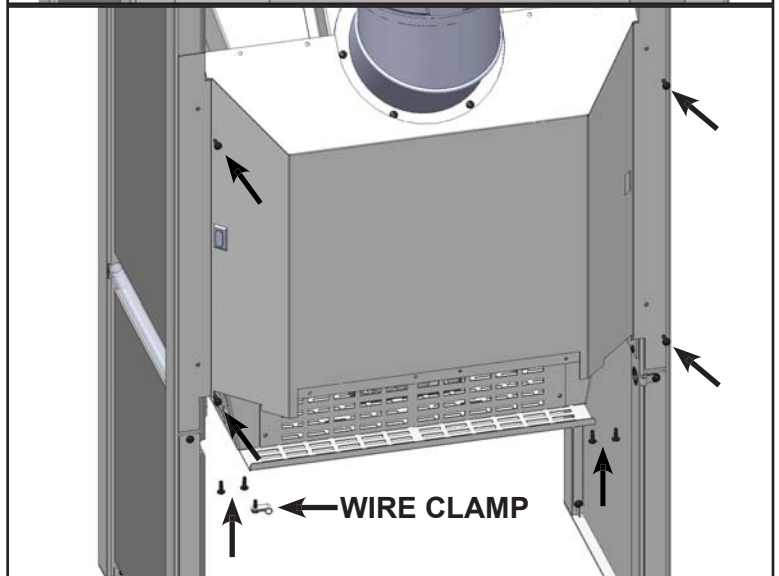

Fig.23

5. Rotate outer rear shield and place below such that the connected wires are not compromised. (Fig.24)

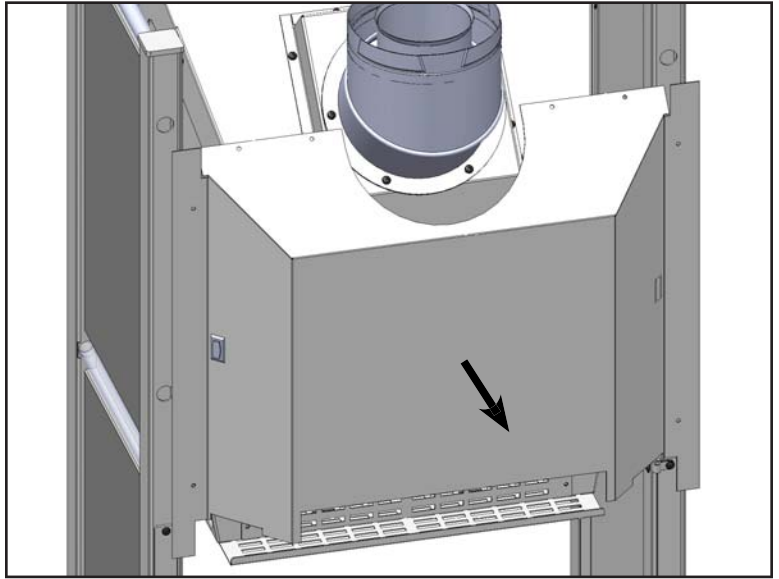

Fig.24

6. Remove screws from flue collar (6 screws). (Fig.25)

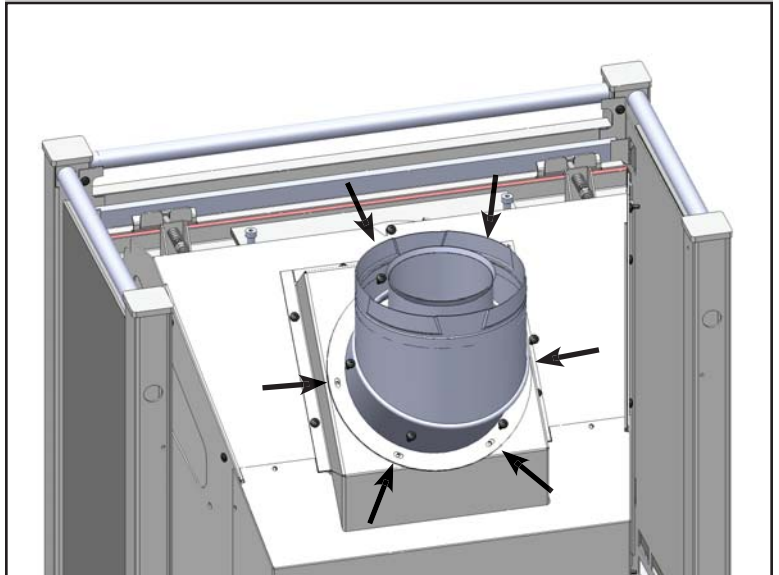

Fig.25

7. Rotate flue collar as shown and re-install to appliance (6 screws). (Fig.26)
8. Re-install rear shield and top rear grill assembly, follow steps 1-3 in reverse order.

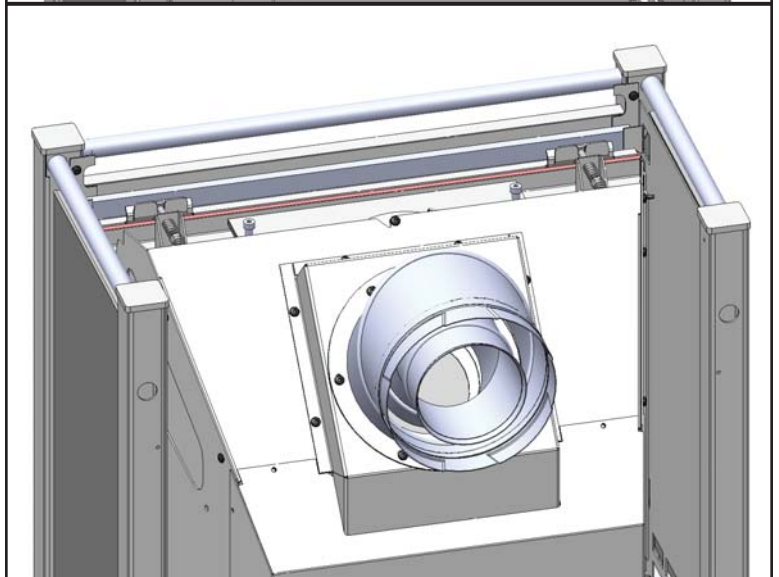
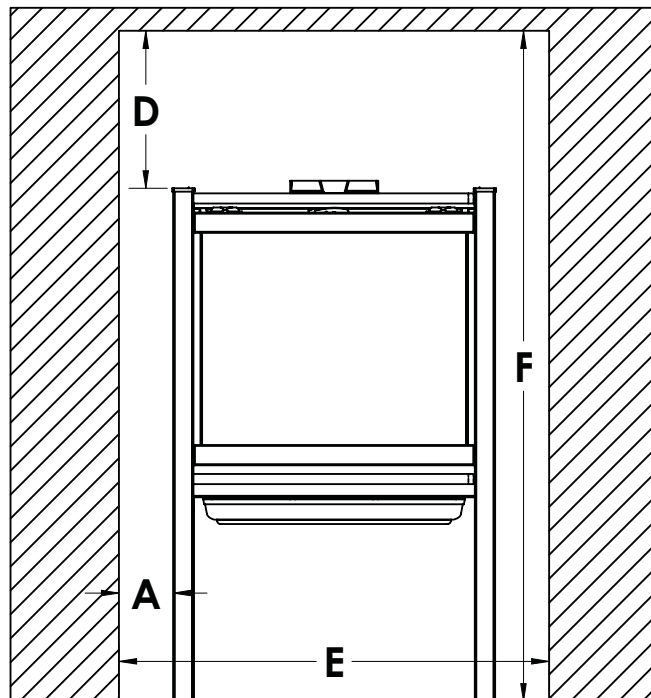
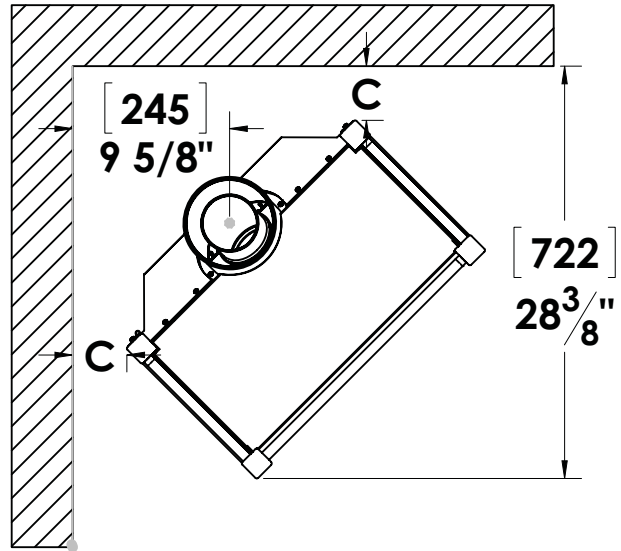
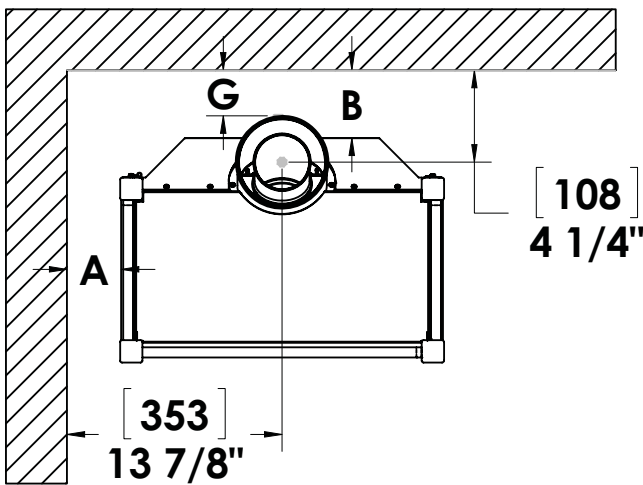

Fig.26

CLEARANCE TO COMBUSTIBLES		
A	Side of unit to sidewall	2" (51 mm)
B	Back of unit to back wall	2.5" (64 mm)
C	Corner of unit to sidewall	2" (51 mm)
D	Top of unit to alcove ceiling	33" (838 mm)
E	Alcove width	27.875" (708 mm)
F	Alcove height	70.5" (1791 mm)
G	Vent	1" (25 mm) from outside surface

**NOTE: CHECK LOCAL CODES FOR FLOOR REQUIREMENTS.
THIS FIREPLACE IS SUITABLE FOR INSTALLATION ON A COMBUSTIBLE SURFACE**



GAS CONNECTIONS

Have your gas supplier or a qualified gas fitter run a gas supply line to the gas fireplace. The line must be properly sized and fitted according to the installation codes. This unit is equipped with a manual shutoff ball valve (**Fig.27**). The outlet has a 1/2" female pipe thread.

⚠ WARNING

THE APPLIANCE AND ITS INDIVIDUAL SHUTOFF VALVE MUST BE DISCONNECTED FROM THE GAS SUPPLY PIPING SYSTEM DURING ANY PRESSURE-TESTING OF THAT SYSTEM AT TEST PRESSURES IN EXCESS OF 1/2 PSI (3.5 KPA). THE APPLIANCE MUST BE ISOLATED FROM THE GAS SUPPLY PIPING SYSTEM BY CLOSING ITS INDIVIDUAL MANUAL SHUTOFF VALVE DURING ANY PRESSURE-TESTING OF THE GAS SUPPLY PIPING SYSTEM AT TEST PRESSURES EQUAL TO OR LESS THAN 1/2 PSIG (3.5 KPA). FAILURE TO DO SO WILL DAMAGE THE APPLIANCE'S GAS VALVE. SUCH DAMAGE IS NOT COVER BY THE MANUFACTURER'S WARRANTY.

- Check for proper gas supply pressure by loosening the set screw on supply pressure tap on the gas valve with a small flat tip screw driver and placing a test gauge on the tap.
- The minimum permissible gas supply pressure is 5.0 in. w.c. (1.24 kPa) for natural gas and 12.0 in. w.c. (3.0 kPa) for propane. Maximum gas supply pressure should never exceed 14.0 in. w.c. (3.48 kPa) or 1/2 psi. for both natural gas and propane.

BE SURE TO TIGHTEN THE PRESSURE TAP SET SCREW AFTER CHECKING THE PRESSURE.

Before connecting the appliance to the gas supply line, double check that the appliance you have purchased is designed for the gas type you are using. The gas type markings are located on the certification label and also on the appliance's gas valve.

Adequate clearance for proper installation and checking of the gas connections must be provided. All gas connections must be checked for gas leaks.

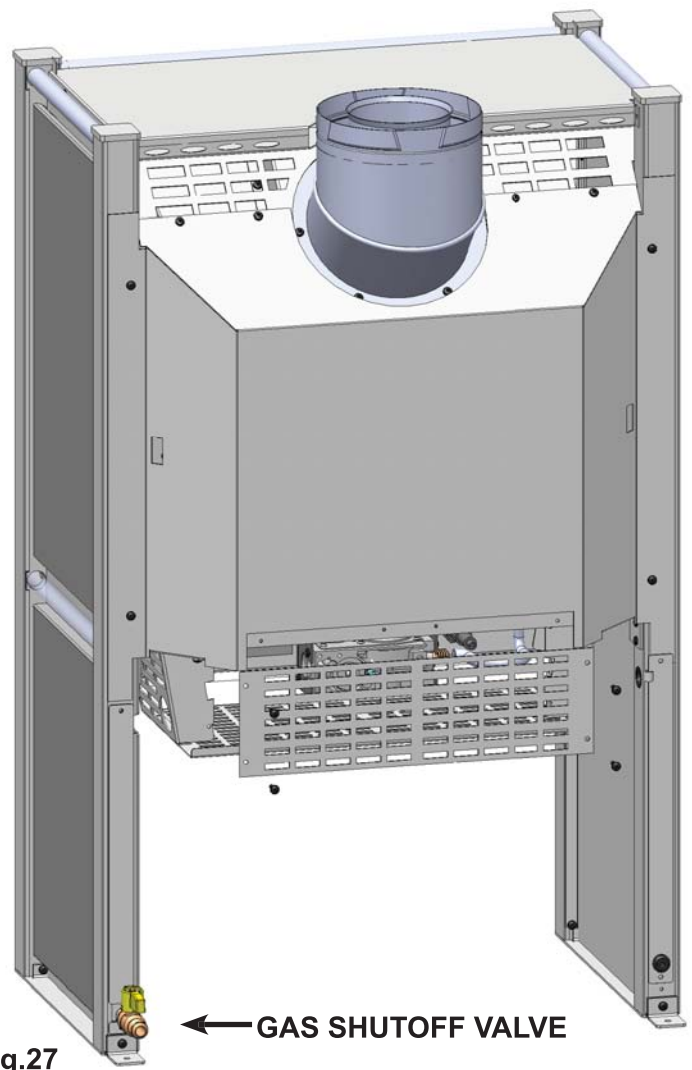
**Fig.27**

⚠ WARNING

A MINIMUM VENT CLEARANCE OF 1" TO COMBUSTIBLES MUST BE MAINTAINED ON VERTICAL PIPE RUNS AND 2" FOR HORIZONTAL PIPE RUNS (SIDES AND BOTTOM 1")

The rigid vent systems use twist lock connections. The flue collar attached to the unit connects to the approved venting system. While you are assembling the pipe bear in mind the best visual appearance. Seams should be aligned and hidden as much as possible. Make sure you twist the mating section all the way to make a solid connection.

As this system is a sealed system, a high temperature sealing compound must be used to seal the metal to metal joint:

Apply a bead of high temperature sealant (non-silicone) to both the 4" exhaust and 6-5/8" intake section of the male pipe. The female section of the pipe/fitting has four indentations evenly spaced around the pipe. These indentations are designed to slide over the male section of the pipe and locate into the four entry slots of the male section of pipe. Twist the female section clockwise a quarter turn to fully lock the sections together.

NOTE: DO NOT USE SILICONE BASED SEALANTS

NOTE: ALLOWING HORIZONTAL VENT PIPE TO SLOPE DOWN TOWARDS THE VENT TERMINATION COULD CAUSE POOR COMBUSTION AND/OR HIGH TEMPERATURES THAT MAY PRESENT A FIRE HAZARD.

Mark a 10" x 10" square around the center mark (inside dimensions). Cut and frame the exterior wall to accept the wall penetration heat shield. Install the penetration shield using wood screws. If the wall being penetrated is constructed of non-combustible material a 7" hole is acceptable for the vent pipe.

CAUTION: When installing the termination on to vinyl siding, a vinyl siding kit must be used. This prevents the termination from being recessed into the siding.

When the termination is to be attached to vinyl siding apply a bead of non-hardening mastic around the outside edge to form a seal between the standoff and the termination cap. Attach the termination cap to the exterior wall inserting four wood screws through the holes in the corner of the vent termination. Complete the installation by applying a bead of mastic around the outer edge of the vinyl standoff.

With the termination cap installed you can now connect the completed vent assembly by sliding the unit back towards the wall and carefully inserting the pipe into the terminal. Before the final connection is made slide on the decorative wall thimble. Secure the termination cap by securing the termination straps to the pipe as close to the exterior wall as possible using sheet metal screws. Ensure that the straps are hidden by the wall thimble cover. Apply decorative trim if required.

VERTICAL VENT INSTALLATION

Always maintain the 1" clearance around the vent pipe (vertical), when passing through ceilings, walls, roofs, enclosures, attic rafters or any combustible surfaces.

DO NOT PACK AIR SPACES WITH INSULATION.

Refer to the vent chart for maximum allowable vertical and horizontal installations.

When planning your installation determine if ceiling joists, roof rafters or other framing will obstruct the vent system. You may have to use 45° elbows to navigate around any obstacles. When passing through a flat ceiling install a Box/Wall thimble. Cut a 10" square hole and frame as shown in (Fig 28).

Ensure all pipe sections are fully twist locked.

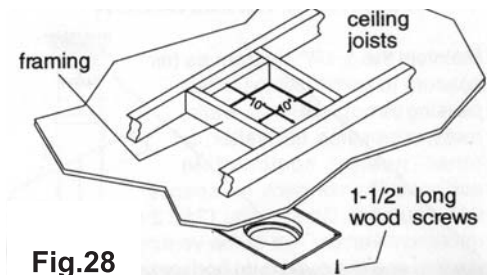
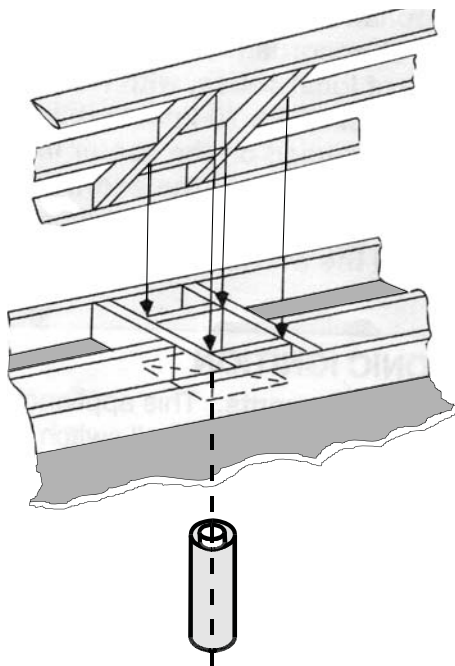

Fig.28

NOTE: Always check your local codes before installing venting. Necessary clearances and requirements may vary from state to state (province to province).

Through Roof Framing

Maintain 10" opening relative to the pitch of the roof.



Use a suitable round or square support through the roof. Ensure adequate heat shield protection is provided.

Termination Above Roof

Consult local codes for minimum vent cap height above the roof, vent must be a minimum 2' from any wall.

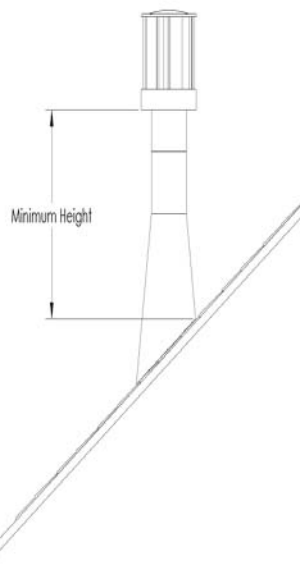

Install the flashing with upper portion slid under the roofing material and the lower portion over the roofing material.

NOTE: DO NOT FASTEN DOWN UNTIL THE FINAL ADJUSTMENTS TO THE VENT HAVE BEEN MADE.

VENTING

This appliance will not function without being connected to a proper venting system. This unit is certified for use with M&G Duravent, BDM, American Metal, Selkirk (Direct-Temp), Olympia, and ICC venting. Read the manufacturer's installation instructions before installing the venting system.

Typical Installation

- 24"(min) vertical vent pipe on top of the appliance,
- One 90° elbow, and up to 24" (max) horizontal run to the outside (with a 2' vertical rise).

Other installations

- Up to 4 - 90° elbows, or equivalent, maximum.
- Minimum 2' (610 mm) straight length between bends.
- The total vertical height up to 36' (10.97 m) maximum.
- Use vent restrictor on vents from 15' (4.57 m) to 20' (6.09 m) to obtain optimal flame appearance, see "VENT RESTRICTOR" and "BURNER FLAME APPEARANCE"
- The total horizontal run up to 20' (6.09 m) maximum.
- Note: 2' (0.6m) minimum of vertical height required.

NOTE: Maximum vent lengths may be subject to local codes.

For best venting performance, here are some general venting rules:

1. Use only vent systems and components certified for use with this appliance.
2. Maintain a minimum of 1" (26 mm) clearance to combustibles from the outside surfaces of vertical vents and minimum of 1" (26 mm) sides and bottom, and 2" (51 mm) from top surfaces of horizontal vents. Always use a wall thimble when passing through combustible construction.
3. Observe all local code restrictions, if any, regarding the installation of this type of gas appliance.
4. Observe the vent height and length restrictions given in this manual.
5. Never slope horizontal vents downwards.
6. Maintain at least an upward slope of 1/4" (7 mm) for every 1 ft (305 mm) of horizontal vent.
7. Terminate the vent with a termination certified for use with this appliance.
8. Support horizontal vent every 3 ft (915 mm) to prevent it from sagging.

VERTICAL VENTING

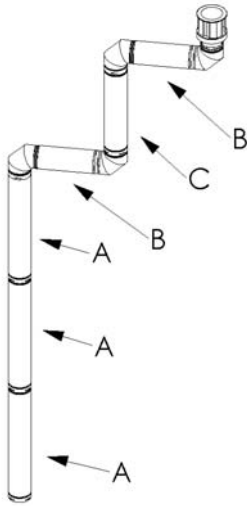

Example 1

V Value = 3A (12') + 1C (3') = 15'

H Value = 2B (4') = 4'

V Value = Total length of all vertical sections in feet.

H Value = Total length of all horizontal sections in feet.

Note:

- for H & V values for 45° venting, see Chart IV
- elbows are not counted in H or V values
- vent chart starts from the top of the unit

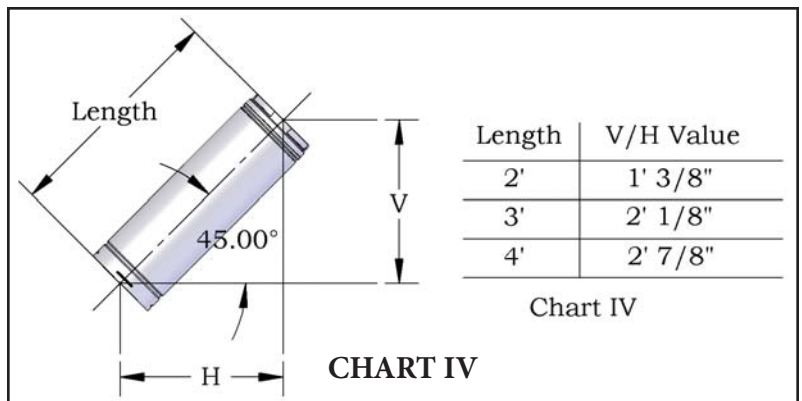
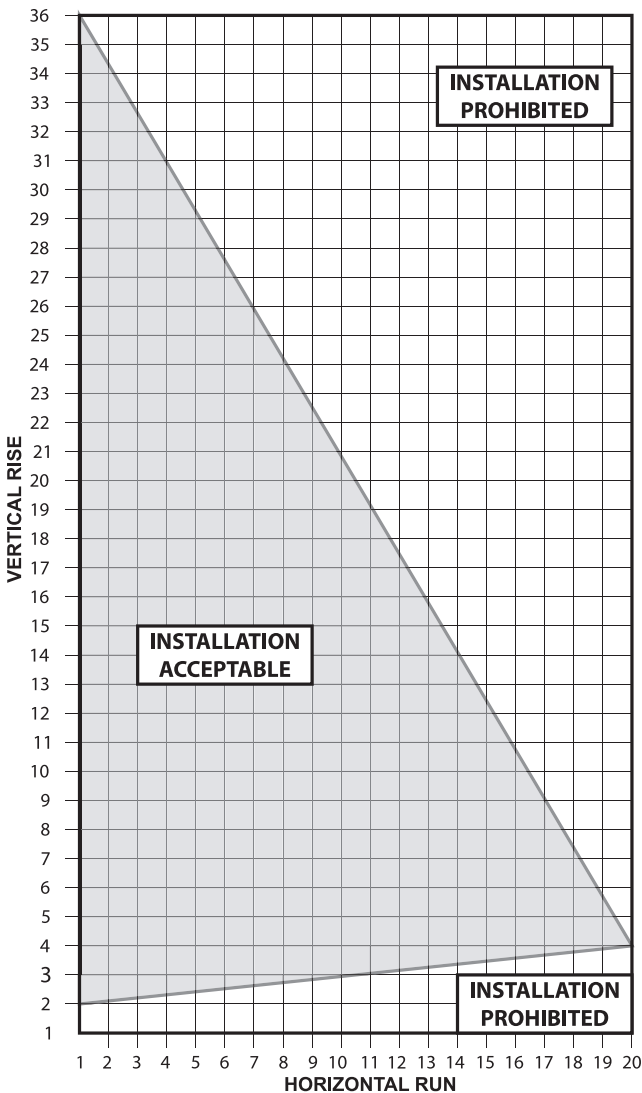

VENT TERMINATION RESTRICTIONS

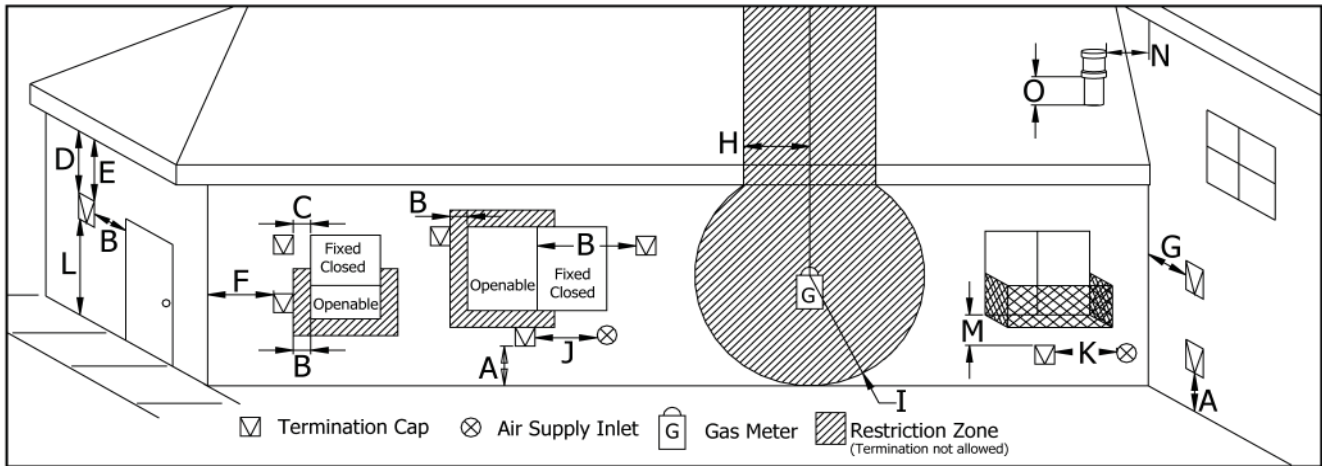

Fig.13 VENT TERMINATION RESTRICTIONS, REFER TO Table 1

Table 1 VENT TERMINATION CLEARANCES

Letter	Canadian Installation ¹	US Installation ²	Description
A	12 in (30 cm)		Clearance above grade, verandah, porch, deck, or balcony.
B	12 in (30 cm)	9 in (23 cm)	Clearance from window or door that may be opened.
C	12 in (30 cm)*		Clearance from permanently closed window (to prevent condensation).
D	24 in (60 cm)*		Vertical clearance to ventilated soffit located above the terminal, within a horizontal distance of 2 ft (60 cm) from center line of terminal.
E	12 in (30.5 cm) to 24" (61 cm)		Clearance to unventilated soffit.
F	12 in (30 cm)*		Clearance to outside corner.
G	12 in (30 cm)*		Clearance to inside corner.
H	3 ft (91 cm) within a height of 15 ft (4.5 m) above the meter/regulator assembly	3 ft (91 cm) within a height of 15 ft (4.5 m) above the meter/regulator assembly*	Clearance to each side of center line extended above meter/regulator assembly.
I	3 ft (91 cm)		Radial clearance around service regulator vent outlet.
J	12 in (30 cm)		Clearance to non-mechanical air supply inlet to building, or the combustion air inlet to any other appliance.
K	6 ft (1.83 m)	3 ft (91 cm) above if within 10 ft (3 m) horizontally	Clearance to mechanical air supply inlet.
L	7 ft (2.13 m) ^t		Clearance above paved sidewalk or paved driveway located on public property.
M	12 in / 30 cm ⁺		Clearance under verandah, porch, deck, or balcony.
N	12 in (30 cm)*		Clearance horizontally to any surface (such as an exterior wall) for vertical terminations.
O	12 in (30 cm)		Clearance above roof line for vertical terminations.

¹ In accordance with the current CSA B149, Natural Gas and Propane Installation Code.

² In accordance with the current ANSI Z223.1 NFPA 54, National Fuel Gas Code.

* These numbers are only estimates.

^t A vent shall not terminate directly above a side walk or paved driveway that is located between two single family dwellings and it serves both dwellings.

⁺ Permitted only if verandah, porch, deck, or balcony is fully open on a minimum of two sides beneath the floor.

Clearances are in accordance with local installation codes and the requirements of the gas supplier.

NOTE: Venting terminals shall not be recessed into walls or siding.

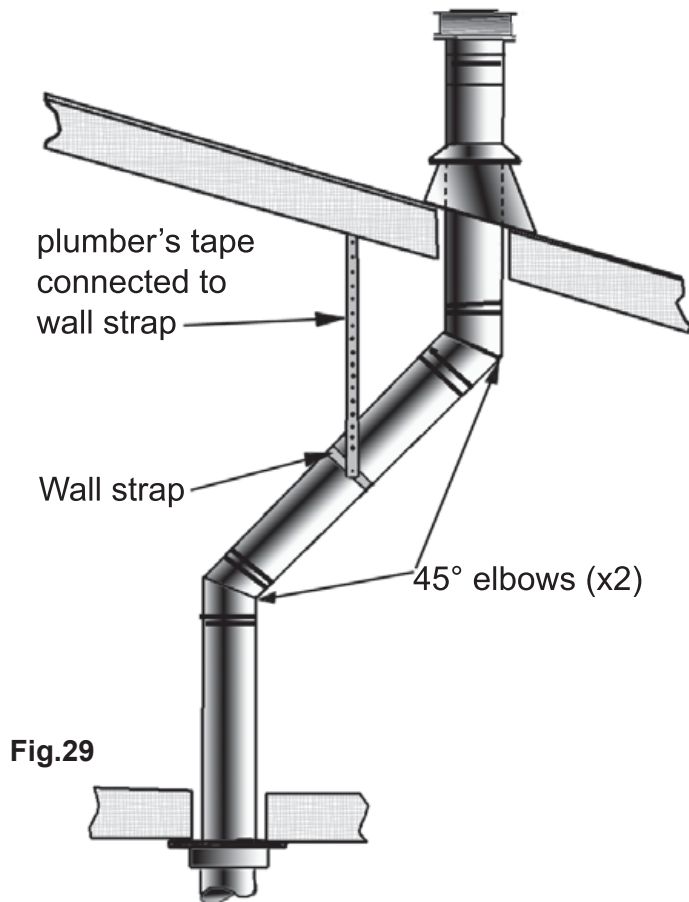

Fig.29

NOTE:

- If an offset is necessary in the attic to avoid obstructions, it is important to support the vent pipe every 3'0" (914 mm), to avoid excessive stress on the elbows, and possible separation. Use wall straps as needed. (Fig.29)
- As much as possible use 45° elbows rather than 90° elbows. With 45° elbows there is less restriction to the flow of flue gases and intake air.
- For multi story installations; a ceiling firestop is required at the second floor, and any subsequent floors (Fig.30). The opening should be framed to 10" (254 mm) x 10" (254 mm) inside dimensions, in the same manner as shown in (Fig.28).
- Any occupied areas above the first floor, including closets and storage spaces, which the vertical vent passes through, must be enclosed. The enclosure may be framed and sheet-rocked with standard building materials. However consult the appliance manufactures installation instructions for the minimum allowable clearance between the outside of the vent pipe, and the combustible surfaces of the enclosure. Do not fill any required air spaces with insulation.

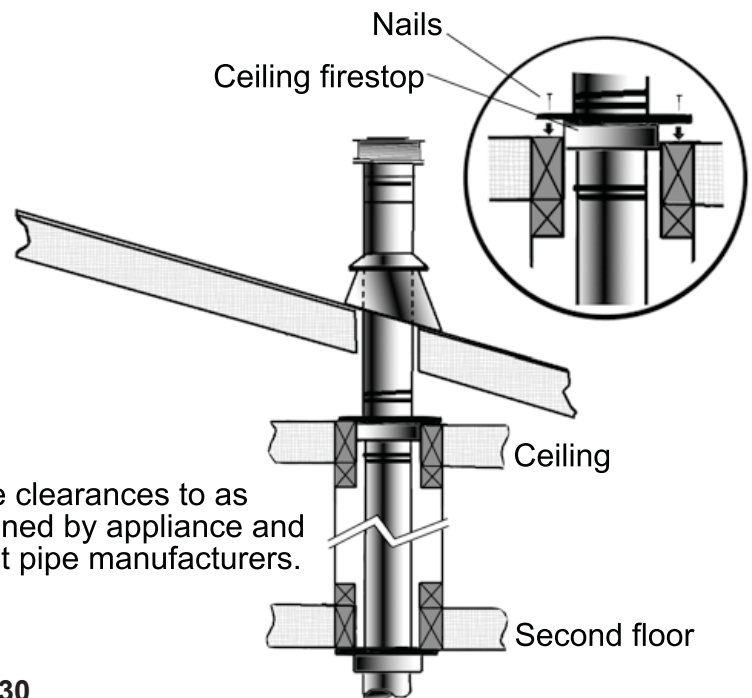
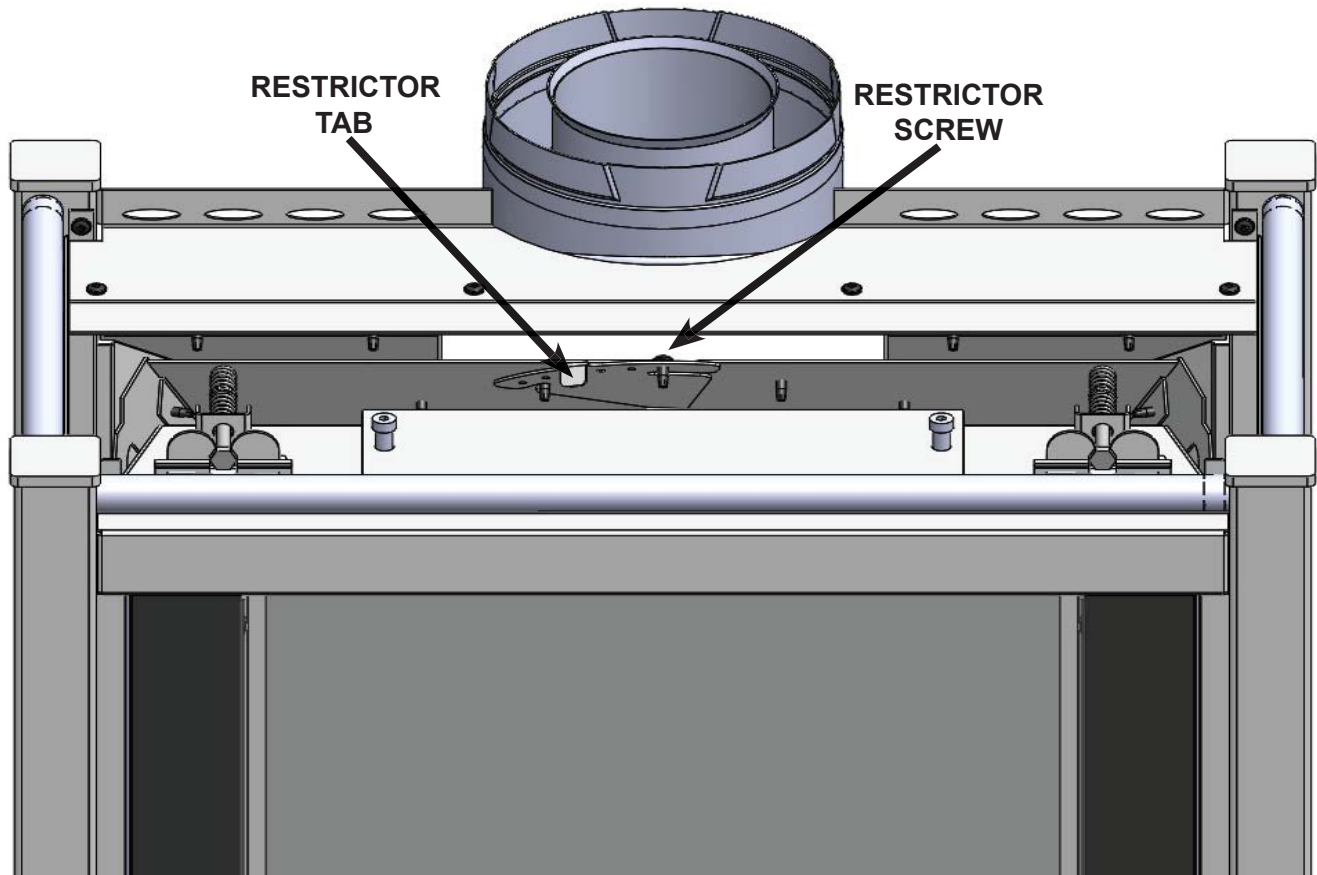

Fig.30

VENT RESTRICTOR

Due to the high draft produced by certain venting configurations the vent restrictor may be adjusted to maintain performance. If vent restriction is necessary it can be adjusted as follows:

1. Turn off the appliance and allow it to cool down completely.
2. Remove the top lid assembly from the top of the appliance and set it aside.
3. Unscrew the restrictor screw and set it aside.
4. Adjust the restrictor tab to one of the six holes to obtain desired flame and screw restrictor screw back into restrictor tab.
5. Reinstall the top lid assembly.

**Fig.31**

AIR SHUTTER ADJUSTMENT

The air shutter allows the amount of air coming into the burner to be adjusted in order to accommodate different climates and venting arrangements.

1. To access the air shutter adjustment lever, open the hinged door beneath the firebox, it is in the upper left-hand side. (Fig.32)
2. Start the pilot and then the burner. Allow the appliance to operate for 15 minutes before making any air adjustments.
3. The ideal flame will be blue at the base and light orange above. If the flames are short and mostly blue, the fireplace is getting too much air. Therefore, the air shutter should be closed slightly until the correct flames are achieved. Slide the air shutter to the right to reduce the amount of air.
4. Flames that are very orange, with tall, dark, stringy tips, are not getting enough air. Therefore, the air shutter should be opened slightly until the correct flames are achieved. Slide the air shutter to the left to increase the amount of air.
5. Tighten air shutter lock screw.

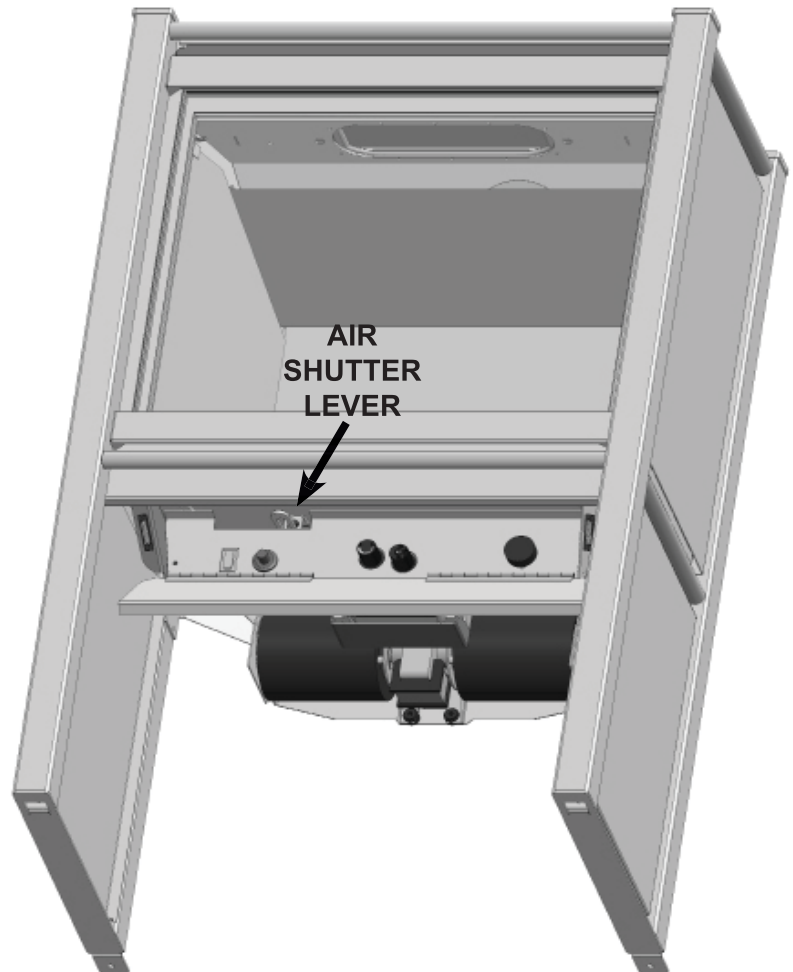

Fig.32

BURNER FLAME APPEARANCE

The ideal flame will be blue at the base and light orange above. If the flames are short and mostly blue, the fireplace is getting too much air. Therefore, the air shutter should be closed slightly until the correct flames are achieved, see air shutter adjustment above.

Flames that are very orange, with tall dark, stringy tips, are not getting enough air. Therefore, the air shutter should be opened slightly until the correct flames are achieved, see air shutter adjustment above.



MOBILE HOME INSTALLATION

The CLARITY 26 FS can be installed in a mobile home but must be securely fastened to the floor. Use the provided mounting brackets to secure the appliance to the hearth or mobile home floor. (Fig.33) Ensure the unit is electrically grounded permanently to the chassis of the home.

⚠ WARNING

THE STRUCTURAL INTEGRITY OF THE MANUFACTURED HOME'S FLOOR, WALL, AND CEILING/ROOF MUST BE MAINTAINED.

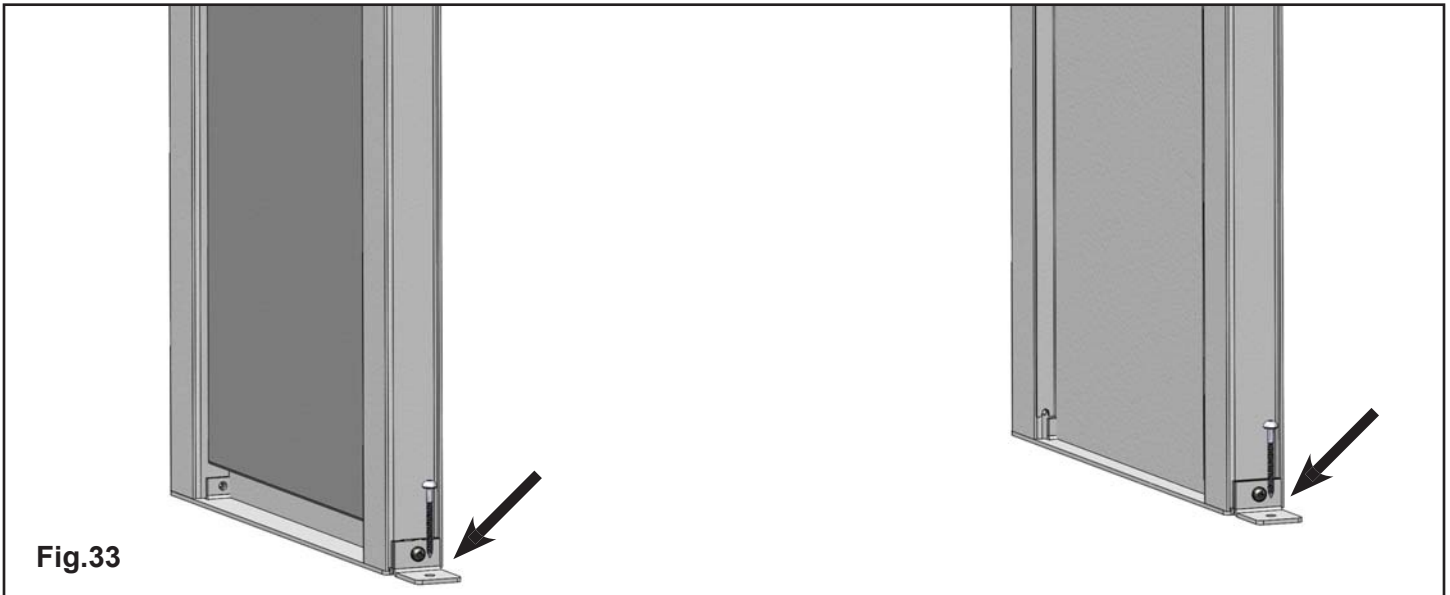

ELECTRICAL REQUIREMENTS:

For CLARITY 26.FS.SP and Z5177.SP FAN KIT

⚠ WARNING

ELECTRICAL GROUNDING INSTRUCTIONS WHEN Z5177.SP FAN KIT IS INSTALLED
THIS APPLIANCE IS EQUIPPED WITH A THREE PRONG (GROUNDING) PLUG FOR YOUR PROTECTION AGAINST SHOCK HAZARD AND SHOULD BE PLUGGED DIRECTLY INTO A PROPERLY GROUNDED THREE PRONG RECEPTACLE . DO NOT CUT OR REMOVE THE GROUNDING PRONG FROM THIS PLUG.

⚠ WARNING**ELECTRICAL GROUNDING INSTRUCTIONS**

LABEL ALL WIRES PRIOR TO DISCONNECTION WHEN SERVICING CONTROLS. WIRING ERRORS CAN CAUSE IMPROPER AND DANGEROUS OPERATION.

⚠ WARNING

VERIFY PROPER OPERATION AFTER SERVICING.

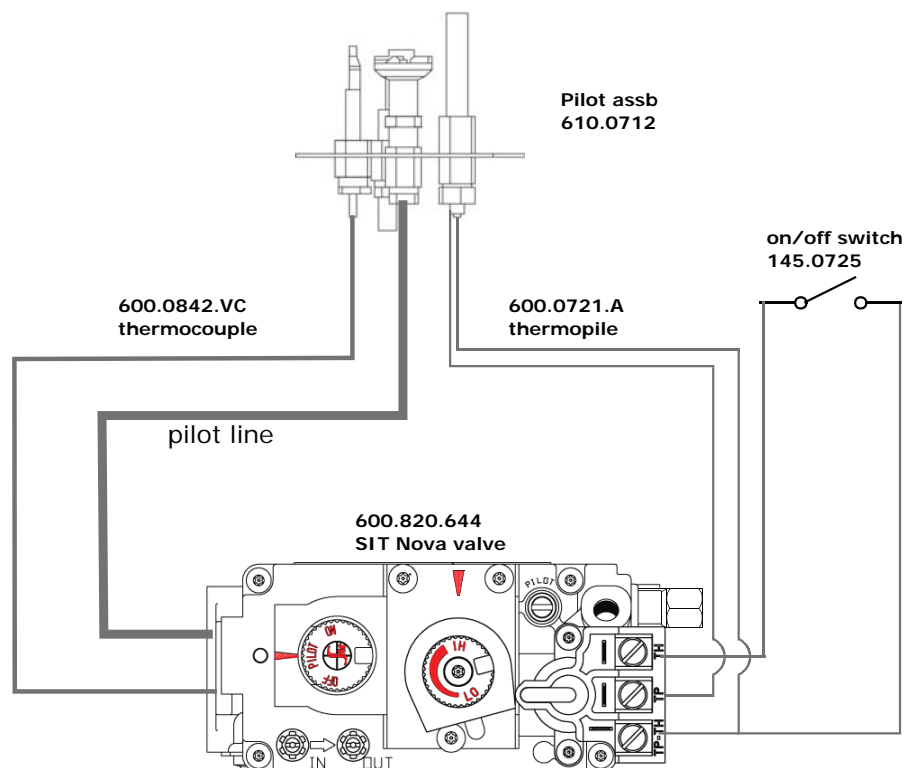
WIRING DIAGRAM

WIRING DIAGRAM OF OPTIONAL THERMOSTAT OR WALL SWITCH

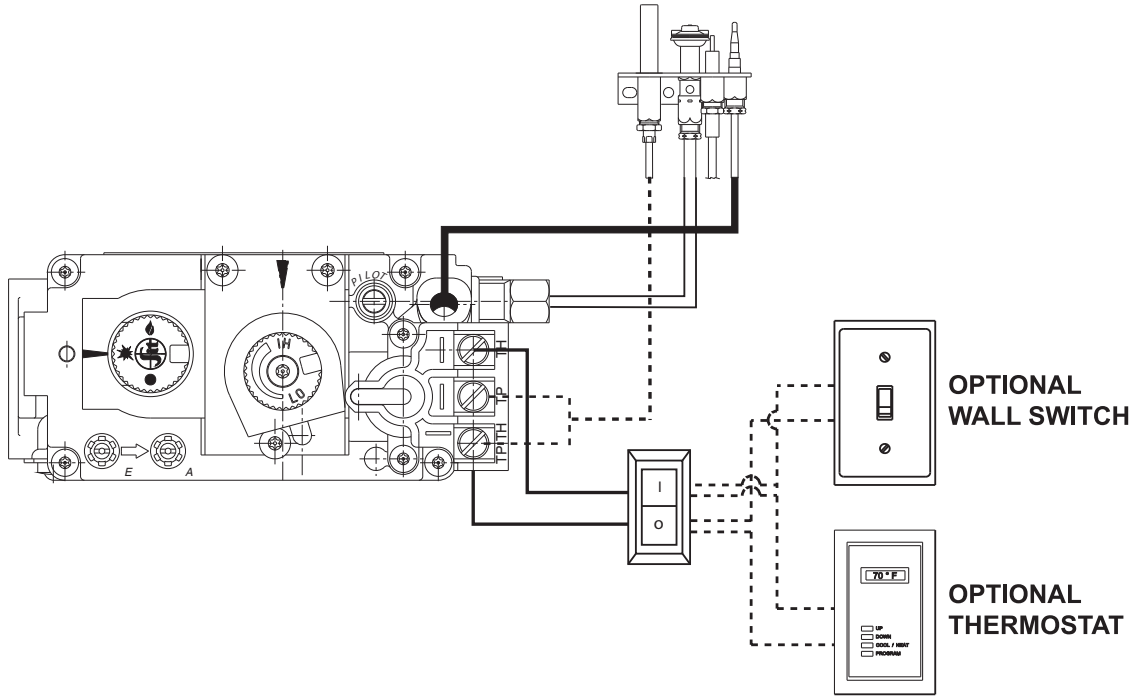

WIRING DIAGRAM FOR CLARITY 26 FS SP BLOWER

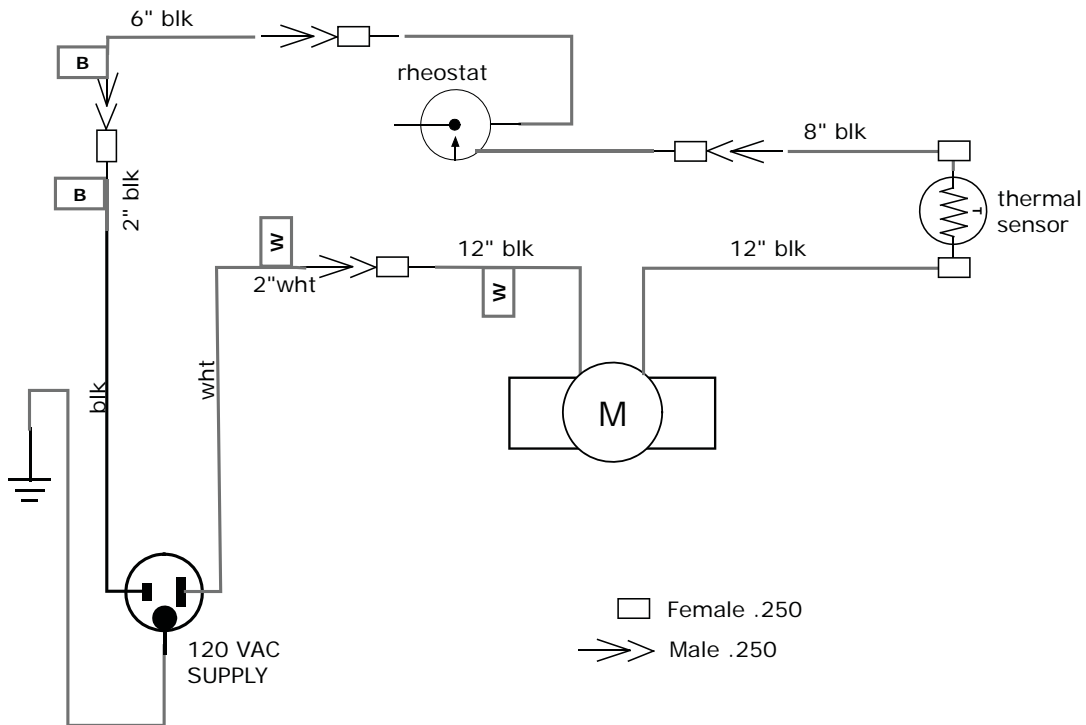

M&G DURAVENT DIRECTVENT PRO / GS SYSTEM PARTS LIST		
DESCRIPTION	PART	OLD PART
6" Pipe Length -Black	46DVA-06B	908B
6" Pipe Length -Galvanized	46DVA-06	908
8,5" Black Extension (3"-7")	46DVA-08AB	-
8,5" Galvanized Extension (3"-7")	46DVA-08A	-
9" Pipe Length-Black	46DVA-09B	907B
9" Pipe Length-Galvanized	46DVA-09	907
12" Pipe Length-Black	46DVA-12B	906B
12" Pipe Length-Galvanized	46DVA-12	906
16" Black Extension (3"-14.5")	46DVA-16AB	-
16" Galvanized Extension (3"-14.5")	46DVA-16A	-
24" Pipe Length-Black	46DVA-24B	904B
24" Pipe Length-Galvanized	46DVA-24	904
36" Pipe Length-Black	46DVA-36B	903B
36" Pipe Length-Galvanized	46DVA-36	903
48" Pipe Length-Black	46DVA-48B	902B
48" Pipe Length-Galvanized	46DVA-48	902
11"- 14 5/8" Adjustable Pipe Length-Black	-	911B
17"- 24" Adjustable Pipe Length-Black	-	917B
45° Elbow-Black	46DVA-E45B	945B, 945BG
45° Elbow-Galvanized	46DVA-E45	945, 945G
90° Elbow-Galvanized	46DVA-E90	990, 990G
90° Elbow-Black	46DVA-E90B	990B, 990BG
Vertical High Wind Termination Cap (must be used for all vertical terminations)	46 DVA-VCH	991
Horizontal. Square Termination Cap	-	984
Wall Thimble Cover—Support Box	46DVA-DC	940
Cathedral Ceiling Support Box	46DVA-CS	941
Brass Trim fro Ceiling Support Box	-	3951
Firestop Spacer	46DVA-FS	963
Flashing 0/12-6/12	46DVA-F6	943
Flashing 7/12-12/12	46DVA-F12	943S
Storm Collar	46DVA-SC	953
Vinyl Siding Standoff	46DVA-VSS	950
Wall Strap	46DVA-WS	988
Wall Pen Heat Shield (Wall Thimble)	46DVA-WT	942
Snorkel H2 termination cap	46DVA-H2-SNK36	

BDM PARTS LIST		
PART	DESCRIPTION	
4" x 6 5/8" DIRECT VENT PIPE:		
94610606	6" GALVANIZED PRO FORM DV PIPE	
94610606B	6" GALVANIZED PRO FORM DV PIPE BLACK	
94610609	9" GALVANIZED PRO FORM DV PIPE	
94610609B	9" GALVANIZED PRO FORM DV PIPE BLACK	
94610612	12" GALVANIZED PRO FORM DV PIPE	
94610612B	12" GALVANIZED PRO FORM DV PIPE BLACK	
94610618	18" GALVANIZED PRO FORM DV PIPE	
94610618B	18" GALVANIZED PRO FORM DV PIPE BLACK	
94610624V	24" GALVANIZED PRO FORM DV PIPE	
94610624B	24" GALVANIZED PRO FORM DV PIPE BLACK	
94610636	36" GALVANIZED PRO FORM DV PIPE	
94610636B	36" GALVANIZED PRO FORM DV PIPE BLACK	
94610648	48" GALVANIZED PRO FORM DV PIPE	
94610648B	48" GALVANIZED PRO FORM DV PIPE BLACK	
4" x 6 5/8" ADJUSTABLE PIPE EXTENSION:		
94610608A	4" to 8.5" GALVANIZED PRO FORM DV ADJUSTABLE PIPE EXTENSION	
94610608AB	4" to 8.5" GALVANIZED PRO FORM DV ADJUSTABLE PIPE EXTENSION BLACK	
94610616A	4" to 16" GALVANIZED PRO FORM DV ADJUSTABLE PIPE EXTENSION	
94610616AB	4" to 16" GALVANIZED PRO FORM DV ADJUSTABLE PIPE EXTENSION BLACK	
DIRECT VENT ELBOWS:		
94620630	30 DEG GALVANIZED PRO FORM DV ELBOW	
94620630B	30 DEG GALVANIZED PRO FORM DV ELBOW BLACK	
94620645	45 DEG GALVANIZED PRO FORM DV ELBOW	
94620645B	45 DEG GALVANIZED PRO FORM DV ELBOW BLACK	
94620660	60 DEG GALVANIZED PRO FORM DV ELBOW	
94620660B	60 DEG GALVANIZED PRO FORM DV ELBOW BLACK	
94620690	90 DEG GALVANIZED PRO FORM DV ELBOW	
94620690B	90 DEG GALVANIZED PRO FORM DV ELBOW BLACKVV	
ELBOW AND WALL STRAPS:		
949264	4" INSIDE 6 5/8" PRO FORM ELBOW STRAP	
949164	4" INSIDE 6 5/8" PRO FORM WALL STRAP	
TYPE	PART	DESCRIPTION
WALL THIMBLES:		
Telescoping	949064S	4" INSIDE 6 5/8" PRO FORM DV TELESCOPING WALL THIMBLE
Universal	949064U	4" INSIDE 5/8" PRO FORM DV UNIVERSAL WALL THIMBLE
TERMINATION CAPS:		
Horizontal Co-Axial	940164	4" INSIDE 6 5/8" HORIZONTAL CO-AXIAL PRO FORM TERM CAP
Horizontal Wind/Heat Shroud:	940164SHRD	4" INSIDE 6 5/8" HORIZONTAL TERMINATION CAP WIND/HEAT SHROUD

BDM PARTS LIST cont.		
TYPE	PART	DESCRIPTION
OTHER COMPONENTS		
Vertical Round Co-Axial Caps:	940264	4" INSIDE 6 5/8" ROUND VCA PRO FORM DV TERM CAP
Ceiling Firestop:	94980612	4" INSIDE 6 5/8" PRO FORM DV CEILING FIRESTOP
Attic Insulation Shield:	94930620A	4" INSIDE 6 5/8" PRO FORM DV ATTIC INSULATION SHIELD (Adjustable)
Cathedral Ceiling Support Kit:	949506KT	4" INSIDE 6 5/8" PRO FORM DV CATHEDRAL CEILING SUPPORT KIT
Decorator Collar:	94940612	4" INSIDE 6 5/8" PRO FORM DV DECORATOR COLLAR
SS Counter Flashing 4 Pc. Kit:	94820615S	4" INSIDE 6 5/8" PRO FORM DV SS COUNTER FLASHING 4 PC. KIT
SS Vinyl Siding Standoff:	94800615S	4" INSIDE 6 5/8" PRO FORM DV SS VINYL SIDING STANDOFF

SELKIRK PARTS LIST		
PRODUCT NUMBER	PART	DESCRIPTION
4" x 6 5/8" LENGTHS		
1604006	4DT- 6	DIRECT-TEMP 6" PIPE LENGTH
1604006B	4DT- 6B	DIRECT-TEMP 6" PIPE LENGTH BLACK
1604009	4DT- 9	DIRECT-TEMP 9" PIPE LENGTH
1604009B	4DT- 9B	DIRECT-TEMP 9" PIPE LENGTH BLACK
1604012	4DT-12	DIRECT-TEMP 12" PIPE LENGTH
1604012B	4DT-12B	DIRECT-TEMP 12" PIPE LENGTH BLACK
1604018	4DT-18	DIRECT-TEMP 18" PIPE LENGTH
1604018B	4DT-18B	DIRECT-TEMP 18" PIPE LENGTH BLACK
1604024	4DT-24	DIRECT-TEMP 24" PIPE LENGTH
1604024B	4DT-24B	DIRECT-TEMP 24" PIPE LENGTH BLACK
1604036	4DT-36	DIRECT-TEMP 36" PIPE LENGTH
1604036B	4DT-36B	DIRECT-TEMP 36" PIPE LENGTH BLACK
1604048	4DT-48	DIRECT-TEMP 48" PIPE LENGTH
1604048B	4DT-48B	DIRECT-TEMP 48" PIPE LENGTH BLACK
1604082	4DT-AJ12	DIRECT-TEMP 12" ADJ PIPE LENGTH
1604082B	4DT-AJ12B	DIRECT-TEMP 12" ADJ PIPE LENGTH BLACK
1604084	4DT-TL14	DIRECT-TEMP TELESCOPIC LENGTH 14"-22"
1604084B	4DT-TL14B	DIRECT-TEMP TELESCOPIC LEN BLACK 14"-22"
1604086	4DT-TL38	DIRECT-TEMP TELESCOPIC LENGTH 38"-70"
1604086B	4DT-TL38B	DIRECT-TEMP TELESCOPIC LEN 38"-70" BLACK
4" x 6 5/8" FITTINGS		
1604215	4DT-EL45	45 DEGREE ELBOW
1604215B	4DT-EL45B	45 DEGREE ELBOW BLACK
1604230S	4DT-EL90S	90S DEGREE ELBOW
1604230SB	4DT-EL90SB	90S DEGREE ELBOW BLACK
4" x 6 5/8" ADAPTERS		
1604245B	4DT-AA	APPLIANCE ADAPTER BLACK
1604246B	4DT-AAV	APPLIANCE ADAPTER VERMONT CASTING BLACK
1604247B	4DT-AA47	APPLIANCE ADAPTER UNIVERSAL/NAPOLEON 4x7
1604806	4DT-VS	VINYL SIDING STANDOFF
4" x 6 5/8" ACCESSORIES		
1604285	4DT-RD	RESTRICTION DISK
1604460B	4DT-WT	WALL THIMBLE BLACK
1604500	4DT-FS	FIRESTOP SPACER
1604502	4DT-TP	TRIM PLATE BLACK
1604806	4DT-VS	VINYL SIDING STANDOFF
2003503	4DTVSK	VINYL SIDING STANDOFF ROUND
1604490	4DT-AIS	ATTIC INSULATION SHIELD

SELKIRK PARTS LIST cont.

PRODUCT NUMBER	PART	DESCRIPTION
4" x 6 5/8" SUPPORTS		
1604400	4DT-CS	CEILING SUPPORT
1604424	4DT-CCS	CATHEDRAL SUPPORT BOX
1604430	4DT-WS/B	WALL SUPPORT/BAND
1604435	4DT-OS	OFFSET SUPPORT
4" x 6 5/8" TERMINATIONS AND FLASHINGS		
1604620	4DT-VKC	VERTICAL TERMINATION KIT
1604621	4DT-HKA	HORIZONTAL TERMINATION KIT "A"
1604622	4DT-HKB	HORIZONTAL TERMINATION KIT "B"
1604802	4DT-VC	HIGH WIND VERTICAL CAP
1604804	4DT-HC	HORIZONTAL CAP
1604810	4DT-SC	STORM COLLAR
1604825	4DT-AF6	ADJ FLASH 0/12-06/12
1604830	4DT-AF12	ADJ FLASH 6/12-12/12
1604838	4DT-ST36	SNORKEL TERMINATION 36"

AMERIVENT PARTS LIST

4" x 6 5/8" LENGTHS

PART	DESCRIPTION	PART	DESCRIPTION
4D7	7" Length	4D90L	90° Elbow
4D7B	7" Length - Black	4D90LB	90° Elbow - Black
4D12	12" Length	4DWT	Wall Thimble
4D12B	12" Length - Black	4DVC	Vertical Cap
4D2	24" Length	502672	Horizontal Cap, Square 4DHCS
4D2B	24" Length - Black	4D36S	Siding Shield for 4DHCS (4DHVS)
4D3	36" Length	4DHWS	Wind Screen
4D3B	36" Length - Black	4DWS	Wall Strap
4D4	48" Length	4DFSP	Firestop Support Plate
4D4B	48" Length - Black	4DF	Flashing - 0/12-6/12 Pitch
4D7A	7" Adjustable Length	4DF12	Flashing - 6/12-12/12 Pitch
4D7AB	7" Adjustable Length - Black	4DSC	Storm Collar
4D12A	12" Adjustable Length	4DAIS12	Attic Insulation Shield
4D12AB	12" Adjustable Length - Black	4DCAT43	Attic Insulation Shield - Cold Climates
4D16A	16" Adjustable Length	4DVTK	Vertical Kit*
4D16AB	16" Adjustable Length - Black	4DHTK1	Horizontal Kit #1**
4D26A	26" Adjustable Length	4DHTK2	Horizontal Kit #2***
4D26AB	26" Adjustable Length - Black	4DFPB	Face Plate for Ceiling Support/Wall Thimble - Black
4D45L	45° Elbow	4DRSB	Roof Support - Black
4D45LB	45° Elbow - Black		

OLYMPIA PARTS LIST			
PART	DESCRIPTION	PART	DESCRIPTION
VDV-0406	4" x 6" L Direct Vent Pipe	VDVB-0424	4"x24"L Direct Vent Black Pipe
VDV-0406-6	4" x 6" DV Pipe 6 Pack	VDVB-0436	4"x36"L Direct Vent Black Pipe
VDV-0406SL	4" x 6" Direct Vent Slip Sec.	VDVB-0448	4"x48"L Direct Vent Black Pipe
VDV-0409	4" x 9" L Direct Vent Pipe	VDVB-04LT	4" Large Telescoping Section
VDV-0409SL	4" x 9" Direct Vent Slip Sec.	VDVB-04MT	4" Medium Telescoping Section
VDV-0412	4" x 12" L Direct Vent Pipe	VDVB-04ST	4" Small Telescoping Section
VDV-0416SL	4" x 16" Direct Vent Slip Sec	VDVB-EL0445	4" x 45" Deg Direct Vent Elbow
VDV-0418	4" x 18" L Direct Vent Pipe	VDVB-EL0490	4" x 90" Deg Direct Vent Elbow
VDV-0424	4" x 24" L Direct Vent Pipe	VDVB-UAA04	4" Universal Appliance Adapter
VDV-0436	4" x 36" L Direct Vent Pipe		
VDV-0448	4" x 48" L Direct Vent Pipe		
VDV-04LT	4" Large Telescoping Section		
VDV-04MT	4" Medium Telescoping Section		
VDV-04ST	4" Small Telescoping Section		
VDV-AIS04	4" Attic Insulation Shield		
VDV-CAC04	4" Co-Linear Appliance Adapter		
VDV-CRS04	4" Round Support Box		
VDV-CSS04	4" Square Support Box		
VDV-EL0445	4" x 45" Deg Direct Vent Elbow		
VDV-EL0445-6	4" x 45" Deg DV Elbow 6 Pack		
VDV-EL0490	4" x 90" Deg Direct Vent Elbow		
VDV-EL0490-6	4" x 90" Deg DV Elbow 6 Pack		
VDV-F0406	4" 0/12-6/12 Flashing		
VDV-F0412	4" 7/12-12/12 Flashing		
VDV-F04F	4" Flat Flashing		
VDV-FS04	4" Fire Stop Shield		
VDV-HC04	4" Direct Vent Horizontal Cap		
VDV-KW04	4" Direct Vent WPT Kit		
VDV-SC04	4" Storm Collar		
VDV-SSO	Siding Stand-Off		
VDV-SSO4	4" Siding Stand-Off		
VDV-VC04	4" Direct Vent Vertical Cap		
VDV-VCH04	4" High Wind Vertical Cap		
VDV-WPT04	4" Direct Vent Wall Pass Thru		
VDV-WS04	4" Wall Support		
VDV-WTC04	4" DirectVent Wall Trim Collar		
VDVB-0406	4" x6"L Direct Vent Black Pipe		
VDVB-0406SL	4" x 6" Direct Vent Slip Sec.		
VDVB-0409	4" x9"L Direct Vent Black Pipe		
VDVB-0409SL	4" x 9" Direct Vent Slip Sec.		
VDVB-0412	4"x12"L Direct Vent Black Pipe		
VDVB-0416SL	4" x 16" Direct Vent Slip Sec		
VDVB-0418	4"x18"L Direct Vent Black Pipe		

ICC PARTS LIST	
4" x 6 5/8" LENGTHS	
DESCRIPTION	PART
6" Length - Galvalume	TC-4DL6
6" Length - Black	TC-4DL6B
9" Length - Galvalume	TC-4DL9
9" Length - Black	TC-4DL9B
12" Length - Galvalume	TC-4DL1
12" Length - Black	TC-4DL1B
12" Slip Length - Galvalume	TC-4DLS1
12" Slip Length - Black	TC-4DLS1B
24" Length - Galvalume	TC-4DL2
24" Length - Black	TC-4DL2B
24" Slip Length - Galvalume	TC-4DLS2
24" Slip Length - Black	TC-4DLS2B
18"-30" Adjustable Length (2 pieces)	TC-4DLA30
18"-30" Adjustable Length - Black (2 pieces)	TC-4DLA30B
36" Length - Galvalume	TC-4DL3
36" Length - Black	TC-4DL3B
48" Length - Galvalume	TC-4DL4
48" Length - Black	TC-4DL4B
4" x 6 5/8" ELBOWS	
Elbow 45° - Galvalume	TE-4DE45
Elbow 45° - Black	TE-4DE45B
Elbow 90° - Galvalume	TE-4DE90
Elbow 90° - Black	TE-4DE90B
Slip Elbow 90°	TE-4DE90S
Slip Elbow 90° - Black	TE-4DE90SB
4" x 6 5/8" SUPPORTS & FIRESTOPS	
Square Support / Radiation Shield	TM-4SS
Round Support / Radiation Shield	TM-4RDS
Ceiling Support / Firestop	TM-4CS
Insulated Wall Thimble	TM-4WT
Wall Thimble Extension	TM-4WTE
Attic Radiation Shield / Firestop	TM-4AS
Ajustable Wall Support	TM-WS
Offset Support	TM-OS
Trim Ring - Black	TM-4TR
Trim Plate - Black	TM-4TP
O'Ring (included with Trim)	TM-4OR
4" x 6 5/8" TERMINATIONS	
Small Vertical Termination (must be used with TM-4SVTS)	TM-4SVT
Rain/Wind Shield for SVT & IVT (must be used with TM-4SVT)	TM-4SVTS
Horizontal Termination	TM-4HT

TO BE DONE BY QUALIFIED PERSONNEL ONLY

1. Disconnect the gas, see gas valve shutoff, and electricity to the appliance.
2. Remove fan if installed.
3. Remove the bottom and rear wire shields (7 screws, 1 ground). (Fig.34)
4. Undo the gas lines (one in, two out , and pilot).
5. Disconnect all electrical connections to valve including ground wire.
6. Remove the four screws holding the valve and valve bracket to the firebox bottom and remove valve. (Fig.35)
7. Installation is the reverse order of the previous steps.

**NOTE: WHEN INSTALLING NEW VALVE, CHECK IF ANY UNUSED PORTS ARE PLUGGED.
CHECK OUTLET PRESSURE (3.8" W.C.) AND CHECK FOR LEAKS**



Fig.34

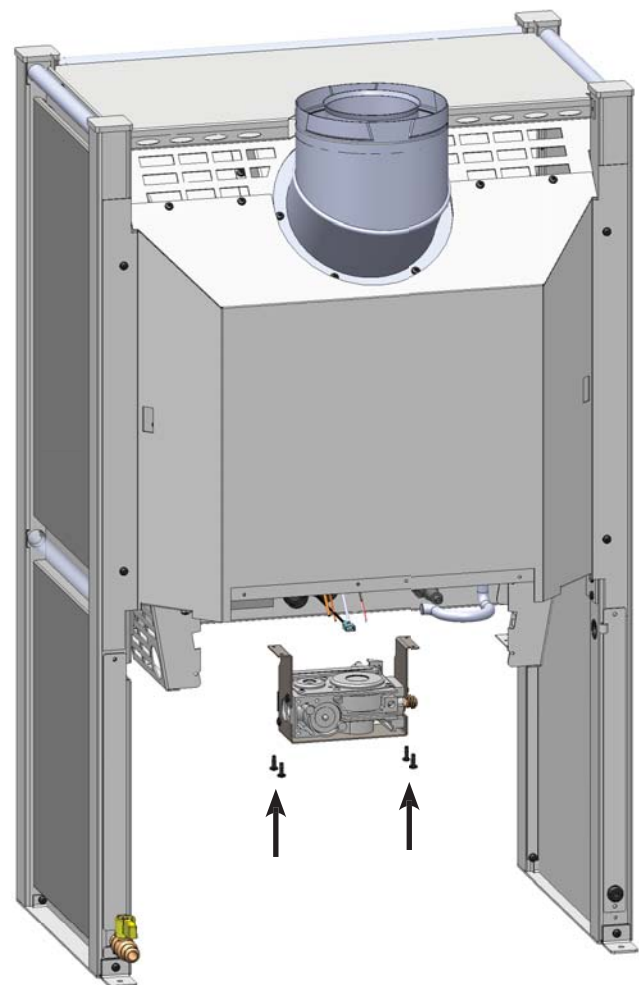
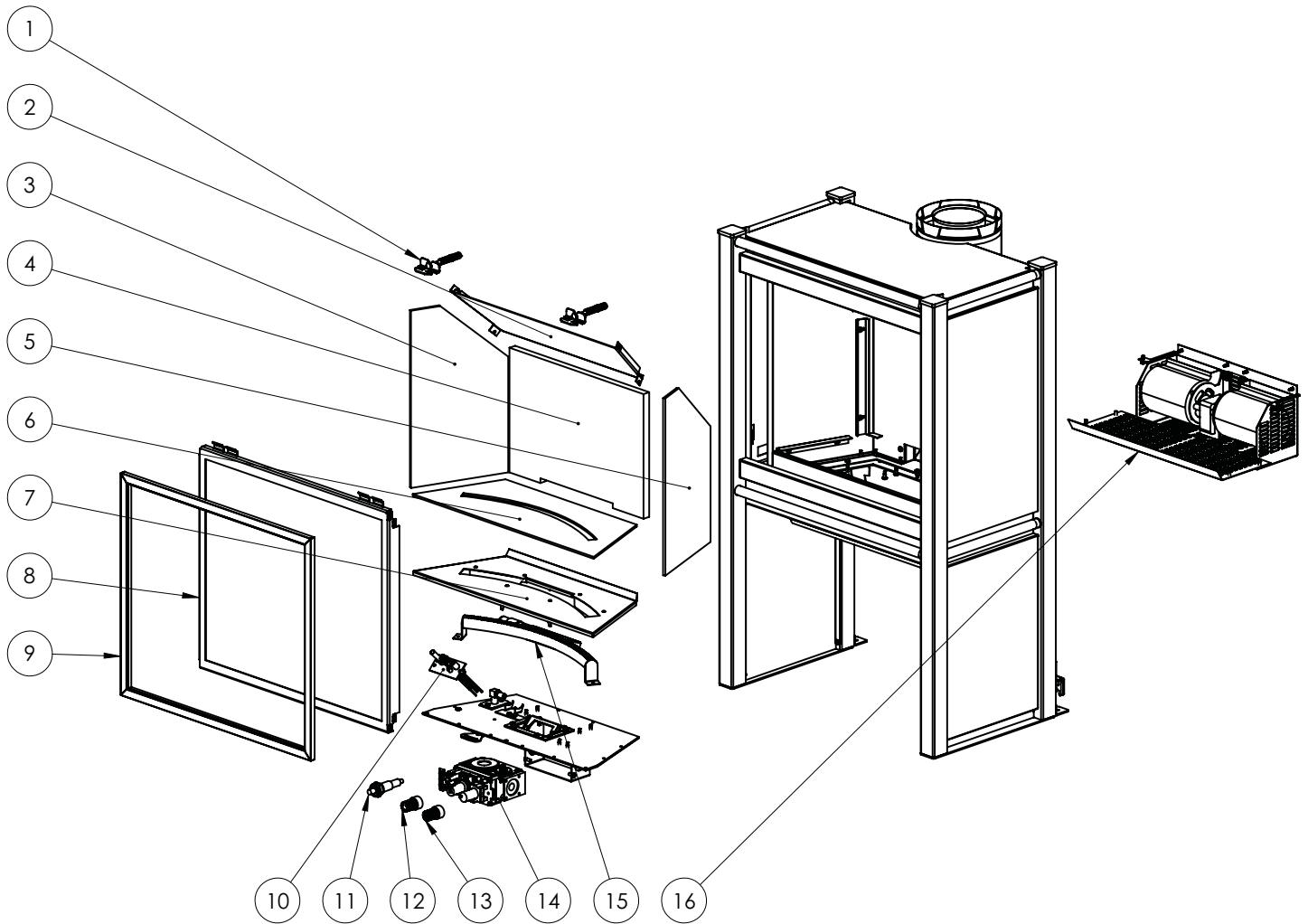

Fig.35



ITEM NO.	PART NUMBER	DESCRIPTION	ITEM NO.	PART NUMBER	DESCRIPTION
1	Z5151	WINDOW LATCH ASSEMBLY	10	610.0712	PILOT ASM ADJ NG/LPG PSE
2	5103	FIREBOX BAFFLE	11	600.SIT.011	PIEZO IGNITER
3	130.0501.L	GLASS CERAM MIRROR LEFT	12	600.SIT.013	EXTENSION KNOB HI/LO 1.5"
4	620.5101	CERAMIC PANEL REAR CLARITY	13	600.SIT.012	EXTENSION KNOB ON/OFF 1.5"
5	130.0501.R	GLASS CERAM MIRROR RIGHT	14	600.820.644	VALVE M/V NOVA NG 3.5-1.6
6	130.0601	BLACK FLOOR GLASS	15	640.5101	BURNER ASSEMBLY
7	Z5104	FLOOR PLATE RIVET ASSEMBLY	16	S.Z5177.SP	OPTIONAL CLARITY FS SP FAN KIT
8	S.Z5175	GLASS DOOR ASSEMBLY			
9	645.1821	SAFETY SCREEN 21" X 18.5"			

Please check to make sure the instructions are followed exactly before attempting trouble shooting of the appliance.

⚠ WARNING

TROUBLESHOOTING AND SERVICING OF GAS AND ELECTRICAL DEVICES OF THE APPLIANCE SHOULD ONLY BE CONDUCTED BY A QUALIFIED SERVICE TECHNICIAN.

PROBLEM	POSSIBLE CAUSE	ACTION
The main burner does not ignite when called for.	The gas valve may not be on.	<ul style="list-style-type: none"> Check that the gas control knob is in the "ON" position.
	Problem with gas valve.	<ul style="list-style-type: none"> Use a DC voltmeter to measure the voltage across the TPTH and TP terminals. Main operator voltage: Open circuit \geq 325mV Closed circuit \geq 100mV If voltage is not present, check the control circuit for proper operation. If proper control system voltage is present, replace the gas control.
Spark will not light the pilot after repeatedly pressing the spark ignitor.	Defective piezo ignitor.	<ul style="list-style-type: none"> Check connections to ignitor. If ignitor connections are good but no spark, replace ignitor.
	Broken spark electrode.	<ul style="list-style-type: none"> Check for broken ceramic insulation, replace electrode if broken.
	Misaligned spark electrode.	<ul style="list-style-type: none"> If spark is not arcing from electrode to pilot, loosen the screws on the pilot base adjust and tighten.
Pilot will not remain lit.	Problem with thermocouple circuit.	<ul style="list-style-type: none"> Check for proper connection of the thermocouple to the rear of the valve. If loose, fully tighten. Check pilot for full flame impingement around thermocouple. If flame is too small, check gas pressure, adjust pilot rate screw, check pilot head for damage. Check thermocouple voltage at valve. It must be greater than 5 mV. If low, replace thermocouple.
	Air in gas line (pilot dies while knob is depressed).	<ul style="list-style-type: none"> Bleed line. Check gas line pressure. Contact dealer
Burners will not remain lit.	Problem with thermopile circuit.	<ul style="list-style-type: none"> Check gas line pressure. Check for flame impingement on thermopile. If low, see "Pilot will not remain lit". Check thermopile for minimum of 300 mV when burner is switched on. Check wiring to thermostat for breaks.
Flame lifting	Leak in vent pipe	<ul style="list-style-type: none"> Check for leaks in vent connections.
	Improper vent configuration	<ul style="list-style-type: none"> Check vent configuration with manual.
	Terminal may be recirculating flue gases	<ul style="list-style-type: none"> Check to see if terminal is on correctly. May need to install high wind termination cap. Contact dealer.
Glass fogs up	Normal Condition: after the appliance warms up the glass will clear. **Due to additives in gas, glass may get hazy during operation** Clean as needed.	
Blue Flames	Normal during start up: flames will yellow as the fireplace heats up.	
Flames are burning "dirty" or sooting	Flame impingement	<ul style="list-style-type: none"> Check log positioning. Increase primary air by opening the venturi shutter and/or by opening the vent restrictor. See also "Burners will not remain lit."

BLAZE KING GAS LIMITED WARRANTY

Blaze King and its respective brands extend the following warranty for gas appliances purchased from an authorized Blaze King dealer and installed in the United States of America or Canada. Warranty starts with date of purchase by the original owner (End User) except as noted for replacement parts.

Warranty Period		Components Covered	
Parts	Labor	Gas	
1 Year		X	All parts, materials and surface finishes (flaking and peeling). Except as covered by Conditions Exclusion, and Limitations listed
2 Years		X	Igniters, Thermocouple, Thermopile Molded Refractory Panels, Log sets, Fan assembly, Ignition components, Gas valve, Burner components, Thermostat
5 Years	2 Years	X	Firebox & Heat Exchanger
10 Years	2 Years	X	All Exterior Steel Cabinets (excluding paint finishes) Glass (thermal breakage only)
1 Year		X	Other Replacement Parts
See Conditions, Exclusions, and Limitations			

Blaze King Gas Limited 10 Year Warranty

Blaze King is the manufacturer of the Blaze King line of heating products. At Blaze King, our commitment to the highest level of quality and customer service is the most important thing we do. Each Blaze King stove is built on a tradition of using only the finest materials and is backed by our limited lifetime warranty to the original purchaser. With Blaze King, you're not just buying a fireplace or stove, you're buying a company with years of unequalled performance and quality.

Limited 10 Year Warranty:

Under this warranty, Blaze King covers the fireplace or stove, exterior body, pedestals, legs and glass (thermal breakage only) against defects in materials and workmanship, for part repair or replacement for (10) years from original purchase date and limited labor for the first two (2) years to the original purchaser. This warranty does not cover exterior finishes. Please see the exclusions and limitation section below as certain restrictions and exclusions apply to this warranty.

Limited 5 Year Warranty:

Under this warranty, Blaze King covers the fireplace or stove firebox and heat exchanger against defects in materials and workmanship, for part repair or replacement for the first five (5) years and limited labor for the first two (2) years to the original purchaser. This Warranty covers: Heat Exchanger, Steel Firebox Panels and any steel components not covered under the ten (10) year Warranty excluding burner components and gas components. Please see the exclusions and limitation section below as certain restrictions and exclusions apply to this warranty.

Limited Two (2) Year Warranty:

Under this warranty, Blaze King covers: Gas Assembly, Burner components (ceramic and steel), Log sets, Blower and control, Temperature Sensors, thermocouple, thermopile, electronic ignition components and wire harness against defects in materials and workmanship, for part repair or replacement for the first two (2) years and limited labor for the first two (2) years to the original purchaser. Please see the exclusions and limitation section below as certain restrictions and exclusions apply to this warranty.

Limited One (1) Year Warranty:

Under this warranty, Blaze King covers all exterior surface finishes against defects in materials and workmanship, for part repair or replacement and limited labor for the first (1) year to the original purchaser. Please see the exclusions and limitations section below as certain restrictions and exclusions apply to this warranty.

How the Warranty Works (Includes Conditions, Exclusions and Limitations)

1. All warranties by the manufacturer are set herein and no claim shall be made against the manufacturer on any oral warranty or representation. All claims under this Limited Warranty must be made in writing by your dealer.
2. Any stove or part thereof that is repaired or replaced during the Limited Warranty period will be warranted under the terms of the Limited Warranty for a period not exceeding the remaining term of the original Limited Warranty or six (6) months, whichever is longer.
3. For any part or parts of this stove, which in our judgment show evidence of defects, Blaze King reserves the option to repair or to replace the defective product through an accredited distributor or agent, provided the defective part is returned to the distributor or agent, transportation prepaid, if requested.
4. If you discover a problem that you think may be covered by the Limited Warranty, you **MUST REPORT** it to your Blaze King dealer **WITHIN 30 DAYS** from the date the problem was first detected, giving them proof of purchase and the date of purchase. The dealer will investigate the problem and work with Blaze King to determine whether the problem:
 - a) Is covered by the Limited Warranty or
 - b) Can be fixed in your home or does the product need to be returned to Blaze King for repair.
5. If Blaze King determines that the stove needs to be returned to Blaze King for repair, the customer has the responsibility and the expense of removing it from their home and shipping it to Blaze King. If the problem is covered by the Warranty, Blaze King will repair or replace the item at their discretion and the customer will be responsible for return shipping and re-installation in their home.
6. If the problem is not covered by the Limited Warranty, the customer will be responsible for all repair costs, as well as all storage, shipping and the cost of removing and re-installing the stove.

If you are not satisfied with the service provided by the Blaze King dealer, write to Blaze King at the address listed on the last page of the Owner's Manual. Include a copy of the original purchase invoice and a description of the problem.

Exclusions and Limitations:

1. This Warranty does not cover tarnish, discoloration or wear on the plated surfaces. Painted finishes will change colour after initial firing and will continue to change through the lifetime of the stove. This is normal occurrence for all high temperature coatings.
2. This Warranty excludes wear and tear or breakage caused by cleaning, moving or service on log set and panels.
3. Blaze King strongly recommends that installation be done by a certified installer. Failure to comply may adversely affect coverage under this warranty. This Limited Warranty covers defects in materials and workmanship only if the product has been installed in accordance with local building and fire codes; in their absence, refer to the owner's manual. If the product is damaged or broken as a result of any alteration, wilful abuse, mishandling, accident, neglect, or misuse of the product, the Limited Warranty does not apply.
4. The stove must be operated and maintained at all times in accordance with the instructions in the Owner's Manual. If the unit shows signs of neglect or misuse, it is not covered under the terms of this Warranty policy. Performance problems due to operator error will not be covered by the Limited Warranty policy.
5. Some minor expansion, contraction, or movement of certain parts and resulting noise, is normal and not a defect and, therefore, is not covered under this Limited Warranty.
6. Misuse includes over-firing. Over-firing this appliance can cause serious damage and will nullify the Limited Warranty.
7. The Limited Warranty will cover glass thermal breakage only and will not cover misuse of the stove glass, including but not limited to glass that is struck, has surface contaminates or has had harsh or abrasive cleaners used on it.
8. This warranty does not cover products made or provided by other manufacturers and used in conjunction with the operation of this stove without prior authorization from Blaze King. The use of such products may nullify the Limited Warranty on this stove. If unsure as to the extent of this Limited Warranty, contact your authorized Blaze King dealer before installation.
9. Blaze King will not be responsible for inadequate performance caused by environmental conditions.
10. The Limited Warranty does not cover installation and operational related problems such as use of downdrafts or spillage caused by environmental conditions. Environmental conditions include but are not limited to nearby trees, buildings, roof tops, wind, hills, mountains, inadequate venting or ventilation, excessive offsets, negative air pressures or other influences caused by mechanical systems such as furnaces, fans, clothes dryers etc.
11. The Limited Warranty is void if:
 - a) The stove has been operated in atmospheres contaminated by chlorine, fluorine or other damaging chemicals.
 - b) The stove is subject to submersion in water or prolonged periods of dampness or condensation.
 - c) Any damage to the unit, combustion chamber or other components due to water, or weather damage which is the result of, but not limited to, improper chimney/venting installation.
 - d) Salt air in coastal areas or high humidity can be corrosive to the finish; these environmental can cause rusting. Damage caused by salt air or high humidity is not covered by the Limited Warranty.
12. Exclusions to the Limited Warranty include: injury, loss of use, damage, failure to function due to accident, negligence, misuse, improper installation, alteration or adjustment of the manufacturer's settings of components, lack of proper and regular maintenance, alteration, or act of God.
13. The Limited Warranty does not cover damage caused to the fireplace or stove while in transit. If this occurs, do not operate the stove and contact your courier and/or dealer.
14. Limited Warranty does not extend to or include firebox paint, door or glass gaskets with damage caused by normal wear and tear, or exterior paint discoloration or chipping, worn gaskets, etc.
15. The Limited Warranty does not include damage to the unit caused by abuse, improper installation, or modification of the unit.
16. Damage to plated surfaces caused by fingerprints, scratches, melted items, or other external scores and residues left on the plated surfaces from the use of abrasive cleaners or polishes is not covered in this warranty.
17. The Limited Warranty does not cover tarnish, discoloration or wear on the plated surfaces.
18. The paint on the brick liner may peel. It is not a flaw and is not covered under warranty, due to extreme conditions in the firebox.

- 19. Blaze King is free of liability for any damages caused by the fireplace or stove, as well as inconvenience expenses and materials. The Limited Warranty does not cover incidental or consequential damages.
- 20. The Limited Warranty does not cover any loss or damage incurred by the use or removal of any component or apparatus to or from the Blaze King fireplace or stove without the express written permission of Blaze King and bearing a Blaze King label of approval.
- 21. Any statement or representation of Blaze King Products and their performance contained in Blaze King advertising, packaging literature, or printed material is not part of the Limited Warranty.
- 22. The Limited Warranty is automatically voided if the fireplace or stove's serial number has been removed or altered in any way. If the stove is used for commercial purposes, it is excluded from the Limited Warranty.
- 23. No dealer, distributor, or similar person has the authority to represent or warrant Blaze King Products beyond the terms contained within the Limited Warranty. Blaze King assumes no liability for such warranties or representations.
- 24. Blaze King will not cover the cost of the removal or re-installation of the stove, hearth, facing, mantels, venting or other components.
- 25. Labor to replace or repair items under this Limited Warranty will be covered per our warranty service fee reimbursement schedule. Labor rates are set per component and as such total labor costs may not be covered.
- 26. If a defect or problem is determined by Blaze King to be non warrantable, Blaze King will not be liable for travel costs for service work. In the event of in-home repair work, the customer will pay any in-home travel fees or service charges required by the Authorized Dealer.
- 27. At no time will Blaze King be liable for any consequential damages which exceed the purchase price of the unit. Blaze King has no obligation to enhance or modify any stove once manufactured (example: as a stove model evolves, field modifications or upgrades will not be performed).
- 28. This Limited Warranty is applicable only to the original purchaser and it is non-transferable.
- 29. This warranty only covers Blaze King Products that are purchased through an authorized Blaze King dealer.
- 30. If for any reason any section of the Limited Warranty is declared invalid, the balance of the warranty remains in effect and all other clauses shall remain in effect.
- 31. The Limited Warranty is the only warranty supplied by Blaze King, the manufacturer of the stove. All other warranties, whether express or implied, are hereby expressly disclaimed and purchaser's recourse is expressly limited to the Limited Warranty.
- 32. Blaze King and its employees or representatives will not assume any damages, either directly or indirectly, caused by improper usage, operation, installation, servicing or maintenance of this stove.
- 33. Blaze King reserves the right to make changes without notice. Please complete and mail the warranty registration card and have the installer fill in the installation data sheet in the back of the manual for warranty and future reference.
- 34. Blaze King is responsible for stocking parts for a maximum of seven (7) years after discontinuing the manufacture or incorporation of the item into its products. An exception to this would be if an OEM supplier is not able to supply a part.

Installer: Please complete the following information

Dealer Name & Address: _____

Installer: _____

Phone #: _____

Date Installed: _____

Serial No.: _____