

Surface vitrée: 233.0468 po²

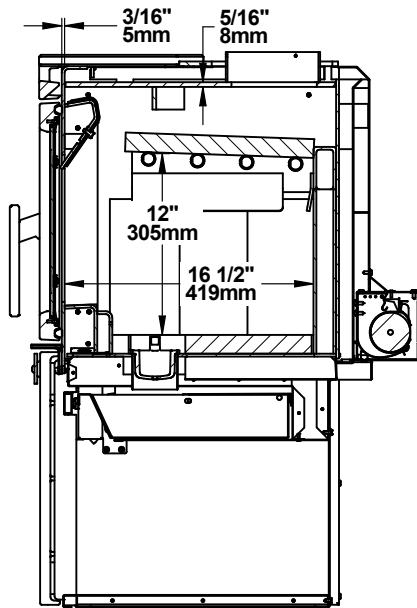

SECTION A-A

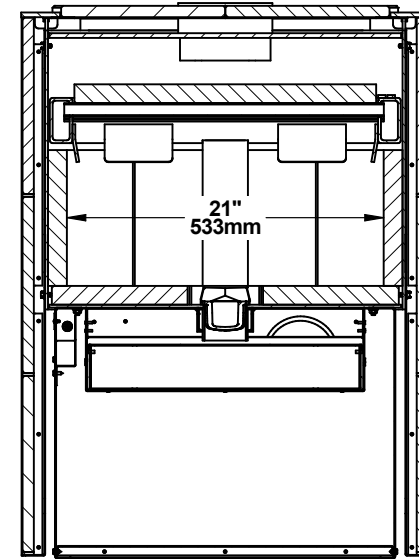

SECTION B-B

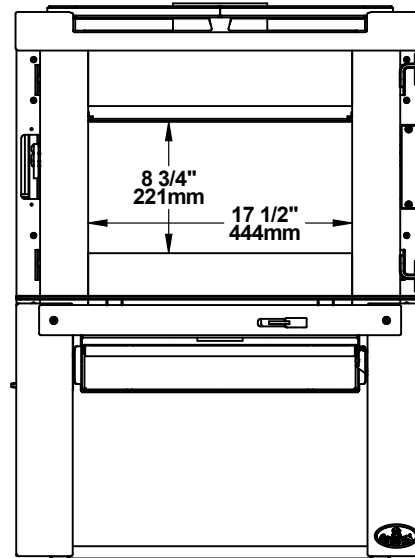

VOLUME CHAMBRE À COMBUSTION:
4158 PO3 / 2.40625 PI3
0.06811 M3

FABRICANT DE POÊLES INTERNATIONALE INC. 250, rue de Copenhague, Saint-Augustin-de-Desmaures (Québec) G3A 2H3 Tél : (418) 878-3040 Fax : (418) 878-3001 www.sbi-international.com		TOLERANCES FRACTION : ± 1/32" XX : ± 0.20" XXX : ± 0.10" ANGLES : ± 0.5°	 THESE ALLOWANCES ARE NOT CUMULATIVE
SBI		NOM DE LA PIÈCE / PART NAME POÊLE OSBURN MATRIX / OSBURN MATRIX STOVE	
CONCEPTEUR E. Blouin		DESSINATEUR J-P Alain	PAGE 4 de 4
		RÉVISIONS / REVISIONS  10/03/2015 DESSIN / DRAWING NBR OB02020-W01	