

# INSTALLATION AND OPERATION MANUAL

## MATRIX Insert

(OB02028 and OB02028K models)



**BEYOND**  
fire

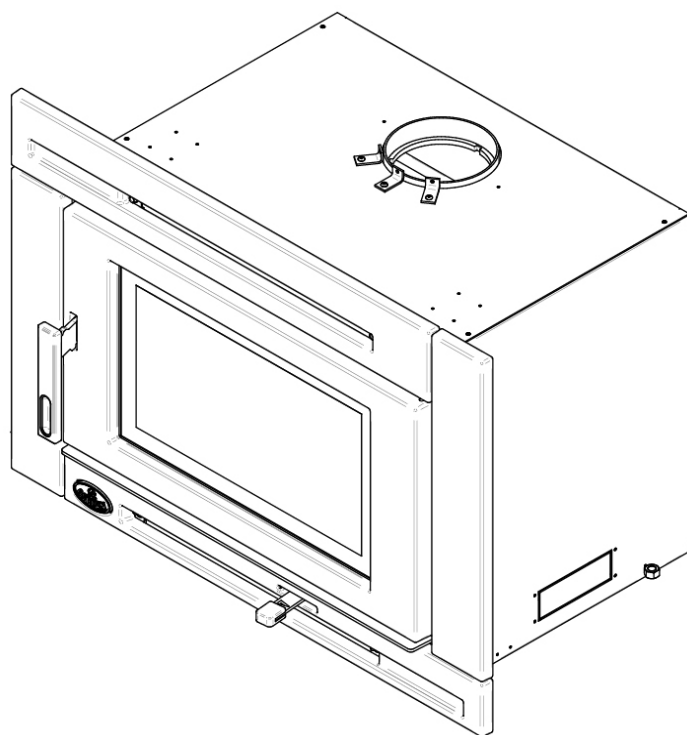

US ENVIRONMENTAL PROTECTION  
AGENCY PHASE II CERTIFIED  
WOOD INSERT

Safety tested according to ULC S628,  
UL 737 and UL 1482 Standards  
by an accredited laboratory



[www.osburn-mfg.com](http://www.osburn-mfg.com)

Stove Builder International Inc.

250, Copenhagen Street, St-Augustin-de-Desmaures (Quebec) Canada G3A 2H3

Customer service: 418-908-8002 E-mail: [tech@sbi-international.com](mailto:tech@sbi-international.com)

**READ AND KEEP THIS MANUAL FOR REFERENCE**

## THANK YOU FOR CHOOSING THIS OSBURN WOOD INSERT

As one of North America's largest and most respected wood stove and fireplace manufacturers, Stove Builder International takes pride in the quality and performance of all its products. We want to help you get maximum satisfaction as you use this product.

In the pages that follow you will find general advice on wood heating, detailed instructions for safe and effective installation, and guidance on how to get the best performance from this insert as you build and maintain fires and maintain your wood heating system.

It is highly recommend that this wood burning hearth product be installed and serviced by professionals who are certified by a «Qualified Agency» such as NFI (National Fireplace Institute®) or CSIA (Chimney Safety Institute of America) in the United States and in Canada by WETT (Wood Energy Technology Transfer) or in Quebec by APC (Association des Professionnels du Chauffage).

Congratulations on making a wise purchase.

**If this insert is not properly installed, combustible materials near it may overheat. To reduce the risk of fire, follow the installation instructions in this manual exactly. Contact local building or fire officials about restrictions and installation inspection requirements in your area.**

**Please read this entire manual before you install and use your new insert. You may need to get a building permit for the installation of this insert and the chimney that it is connected to. Consult your municipal building department or fire department before installation. We recommend that you also inform your home insurance company to find out if the installation will affect your policy.**

**This heating unit is designed to serve as a supplementary heat source. We recommend that a primary heat source also be available in the home. The manufacturer cannot be responsible for costs associated with the use of another heating system.**

### **REGISTER YOUR WARRANTY ONLINE**

To receive full warranty coverage, you will need to show evidence of the date you purchased your insert. Keep your sales invoice. We also recommend that you register your warranty online at:

<https://www.osburn-mfg.com/en/warranty/warranty-registration/>

Registering your warranty online will help us to quickly track the information we need about your insert.

## Table of content

<b>PART A - OPERATION AND MAINTENANCE .....</b>	<b>7</b>
<b>1 Safety Information .....</b>	<b>7</b>
<b>2 General Information .....</b>	<b>8</b>
2.1 Performances.....	8
2.2 Specifications.....	9
2.3 Dimensions .....	10
2.4 Zone Heating and How to Make it Work.....	11
2.5 The Benefits of Low Emissions and High Efficiency.....	12
2.6 The SBI Commitment.....	12
2.6.1 What is Your New Insert Made Of? .....	12
<b>3 Fuel.....</b>	<b>13</b>
3.1 How to Prepare or Buy Good Firewood .....	13
3.1.1 What is Good Firewood? .....	13
3.1.2 Tree Species .....	13
3.1.3 Log Length.....	14
3.1.4 Piece Size.....	14
3.1.5 How to Dry Firewood .....	15
3.1.6 Judging Firewood Moisture Content .....	16
3.2 Manufactured Logs.....	16
<b>4 Operating the Insert .....</b>	<b>17</b>
4.1 Before Operating the Insert.....	17
4.2 The Use of a Fire Screen. ....	17
4.3 Blower Operation .....	17
<b>5 Burning wood efficiently.....</b>	<b>18</b>
5.1 The First Fires.....	18
5.2 Lighting Fires.....	19
5.2.1 Conventional Method .....	19
5.2.2 The Top Down Method .....	19
5.2.3 Two Parallel Logs Method.....	20
5.2.4 Using Fire Starters.....	20
5.3 Maintaining Wood Fires .....	20
5.3.1 General Advice .....	20
5.3.2 Ash Removal.....	21

- 5.3.3 Raking Charcoal.....21
- 5.3.4 Firing Each New Load Hot .....21
- 5.3.5 Controlling the Air intake.....22
- 5.4 fire types.....22
  - 5.4.1 Small Fires to Take the Chill Off the House.....22
  - 5.4.2 Long Lasting Low Output Fires.....23
  - 5.4.3 High Output Fires for Cold Weather .....23
  - 5.4.4 Maximum Burn Cycle Times .....23
  - 5.4.5 Logs Orientation.....24
- 6 Maintaining the Wood Heating System..... 24**
  - 6.1 Insert Maintenance .....24
    - 6.1.1 Cleaning Door Glass .....24
    - 6.1.2 Door Adjustment.....25
    - 6.1.3 Replacing the Door Gasket.....25
    - 6.1.4 Replacing the Glass or the Glass Gasket .....26
    - 6.1.5 Cleaning and Painting the Insert.....27
    - 6.1.6 Firebricks.....27
  - 6.2 Chimney Maintenance.....27
    - 6.2.1 Why Chimney Cleaning is Necessary? .....27
    - 6.2.2 How Often Should the Chimney be Cleaned? .....27
    - 6.2.3 Sweeping the Chimney .....28
- PART B - INSTALLATION ..... 29**
- 7 Masonry fireplace requirements..... 29**
- 8 Safety Information and Standards ..... 30**
  - 8.1 Regulations Covering Insert Installation.....30
- 9 Clearances to Combustible Material ..... 31**
  - 9.1 Certification Label.....31
  - 9.2 Masonry Fireplace Throat Damper.....31
  - 9.3 Installation of a Combustible Mantel Shelf .....32
  - 9.4 Floor Protection .....32
    - 9.4.1 Installation Raised of 5" and Less .....34
    - 9.4.2 Installation Raised of More than 5" .....34
    - 9.4.3 R Value .....35
  - 9.5 Minimum Masonry Opening, Clearances to Combustibles.....36

**10 The Venting System ..... 37**

- 10.1 General .....37
- 10.2 Block-Off Plate .....37
- 10.3 Suitable Chimneys .....38
- 10.4 Liner installation .....38
- 10.5 liner Connection .....39
  - 10.5.1 Liner Starter Adaptor .....39
  - 10.5.2 Liner Offset Adaptor .....40
- 10.6 Minimum Chimney Height.....40
- 10.7 Chimney Location .....41
- 10.8 Supply of Combustion Air .....41

**Appendix 1: Installing the Faceplate..... 43**

**Appendix 2: Installing the Optional Fire Screen ..... 45**

**Appendix 3: Installing the Optional Fresh Air Intake Kit..... 46**

**Appendix 4: Blower Replacement ..... 47**

**Appendix 5: Installation of Secondary Air Tubes and Baffle ..... 49**

**Appendix 6: Removal Instructions..... 51**

**Appendix 7: Exploded Diagram and Parts List..... 52**

**OSBURN LIMITED LIFETIME WARRANTY ..... 56**

Dealer:	_____
Installer:	_____
Telephone:	_____
Serial number:	_____

# CERTIFICATION PLATE



**STANDARDS / NORMES D'ESSAI:**  
 Certified to / Certifié selon ULC S628  
 Certified to / Certifié selon UL 1482  
 Certified to / Certifié selon UL 737  
 CSA B415.1-10  
 Control number: 4002461  
 (March/Mars 2018)

**LISTED SOLID FUEL BURNING  
 INSERT APPLIANCE**

**APPAREIL ENCASTRABLE À  
 COMBUSTIBLE SOLIDE HOMOLOGUÉ**

**MODEL / MODÈLE :  
 MATRIX-I**

Serial Number / No. de Série: 0

**Clearances to combustibles / Dégagements aux combustibles**

Measured from door opening / Mesuré à partir de l'ouverture de porte

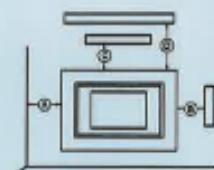

**Blower / Ventilateur:  
 115VOLTS, 0.8 AMPS, 60Hz**

Combustible side wall / Mur côté adjoint	A: 15 in./po. (406 mm)
Combustible side surround [1] / Parement latéral combustible [1]	B: 9 in./po. (229 mm)
Combustible top surround [1] / Parement supérieur combustible [1]	C: 27 in./po. (686 mm)
Combustible mantle shelf [1] / Tablette combustible [1]	D: 27 in./po. (686 mm)
Combustible top surround with shield [1][2] / Parement supérieur combustible avec écran [1][2]	C: 21 in./po. (533 mm)
Combustible mantle shelf with shield [1][2] / Tablette combustible avec écran [1][2]	D: 21 in./po. (533 mm)

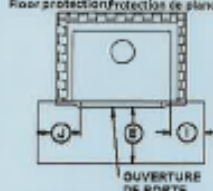

**Floor protection/protection de plancher**

**OUVERTURE DE PORTE**

E: 16 in./po. (406 mm) USA
18 in./po. (457 mm) CANADA
I: 8 in./po. (203 mm) CANADA
II: 8 in./po. (203 mm) USA

[1] Subject to a maximum protrusion (consult owner's manual) / Sujet à une saillie maximale (consultez le manuel d'instructions)

[2] Consult owner's manual for additional details concerning shield / Pour plus de détails sur l'écran consulter le manuel de l'utilisateur.

**PREVENT HOUSE FIRES**

- Install and use only in accordance with the manufacturer's installation and operating instructions.
- Contact local building or fire officials about restrictions and installation inspection in your area.
- Use with solid wood fuel only. Do not use other fuels.
- Risk of smoke and flame spillage. Operate only with door closed or door open with screen door installed. Open door or remove screen door only to feed the stove.
- Do not connect this unit to a chimney serving another appliance.
- Install only in masonry fireplaces. Do not remove bricks or mortar from masonry fireplace.
- The non-combustible floor protection in front of the unit should have an R value equal or greater than 1.00 extending 23 inches (584 mm) in front of the insert if the hearth elevation is lower than 5 inches (127 mm) or extend 16 inches (406 mm) (USA), 18 inches (457 mm) (CANADA) without a R value if the hearth elevation is higher than 5 inches (127 mm).
- Connect to a code-approved masonry chimney or listed factory-built fireplace chimney with a direct flue connector into the first chimney floor section.
- Do not overfire. If stove or chimney connector glows, you are overfiring.
- Inspect and clean chimney frequently. Under certain conditions of use, creosote buildup may occur rapidly.
- Do not use grate or elevate fire. Build wood fire directly on hearth.
- Replace glass only with ceramic glass.
- This wood heater needs periodic inspection and repair for proper operation. Consult the owner's manual for further information. It is against US federal regulations to operate this wood heater in a manner inconsistent with the operating instructions in the owner's manual.

**PRÉVENEZ LES INCENDIES**

- Installer et utiliser conformément au manuel d'utilisation du fabricant.
- Contacter les autorités de votre localité ayant juridiction concernant les restrictions et inspections d'installation.
- Utiliser avec le bois seulement. Ne pas utiliser d'autres combustibles.
- Risque de fuite de fumée et de flammes. Utiliser l'appareil la porte fermée ou ouverte avec le pare-étincelle en place uniquement. Ouvrir la porte ou retirer le pare-étincelle seulement lors du chargement.
- Ne pas raccorder à un conduit de fumée servant déjà pour un autre appareil.
- Installer seulement dans un foyer de maçonnerie. Ne pas enlever les briques ou le mortier du foyer de maçonnerie.
- La protection de plancher incombustible au devant de l'encastable devrait avoir un facteur d'isolation R égal ou supérieure à 1.00 et se prolonger 23 pouces (584 mm) au devant de l'appareil lorsque l'âtre possède moins de 5 pouces (127 mm) d'élévation et se prolonger 16 pouces (406 mm) (USA), 18 pouces (457 mm) (CANADA), sans facteur d'isolation R au devant de l'encastable lorsque l'âtre possède plus de 5 pouces (127 mm) d'élévation.
- Raccorder à une cheminée de maçonnerie respectant les codes ou à une cheminée préfabriquée homologuée, directement à la première section de cheminée gainée.
- Ne pas surchauffer. Si l'appareil ou le tuyau rougit, il y a surchauffe.
- Inspecter et nettoyer la cheminée fréquemment. Dans certaines conditions, la formation de crasse peut être rapide.
- Ne pas utiliser de chenets ou de grilles pour élever le feu. Préparer le feu directement sur l'âtre.
- Remplacer le verre avec un verre de céramique.
- Cet appareil de chauffage requiert des inspections et réparations périodiques. Consultez le manuel de l'utilisateur pour plus d'information. Opérer cet appareil de chauffage de façon inconsistante par rapport au manuel de l'utilisateur constitue une violation de la loi fédérale (USA).

U.S. ENVIRONMENTAL PROTECTION AGENCY Certified to comply with 2020 particulate emission standards using cordwood.  
 AGENCE DE PROTECTION DE L'ENVIRONNEMENT DES É.-U. Conforme aux normes d'émission de particules de 2020 avec bûche de bois.  
 Weighted average emission rate / Moyenne pondérée des émissions: 1.54 g/h  
 When tested in accordance with / Lorsque testé selon: ASTM E2515  
 Tested and certified in compliance with CFR 40 part 60, subpart AAA, section 60.534a(1)(1) and Draft ASTM W647329-14



**CAUTION**

- HOT WHILE IN OPERATION.
- DO NOT TOUCH. KEEP CHILDREN, CLOTHING AND FURNITURE AWAY.
- CONTACT MAY CAUSE SKIN BURNS. SEE NAME-PLATE AND INSTRUCTIONS.



**ATTENTION**

- CHAUD EN FONCTIONNEMENT.
- NE PAS TOUCHER. GARDER LES ENFANTS, LES VÊTEMENTS ET LES MEUBLES ÉLOIGNÉS.
- UN CONTACT AVEC LA PEAU PEUT OCCASIONNER DES BRÛLURES. VOIR LES INSTRUCTIONS.

Made in St-Augustin-de-Desmaures (Qc), Canada  
 26/03/2018 (# test)



Fabriqué à St-Augustin-de-Desmaures (Qc), Canada  
 26/03/2018 (# test)

Fabricant de poêles international  
 Stove Builder International

27722

## PART A - OPERATION AND MAINTENANCE

### 1 SAFETY INFORMATION

- Operate only with the door fully closed or fully open with the fire screen in place. If the door is left partly open, gas and flame may be drawn out of the opening, creating risks from both fire and smoke.
- **HOT WHILE IN OPERATION, KEEP CHILDREN, CLOTHING AND FURNITURE AWAY. CONTACT MAY CAUSE SKIN BURNS. GLOVES MAY BE NEEDED FOR INSERT OPERATION.**
- Using an insert with cracked or broken components, such as glass, firebricks or baffle may produce an unsafe condition and may damage the insert.
- Open the air control fully before opening the loading door.
- This insert has been tested for use with an open door in conjunction with a fire screen, sold separately. The door may be open, or fire screen removed only during lighting procedures or reloading. Always close the door or put back the fire screen after ignition. Do not leave the insert unattended when the door is opened with or without the fire screen.
- **NEVER USE GASOLINE, LANTERN FUEL (NAPHTHA), FUEL OIL, MOTOR OIL, KEROSENE, CHARCOAL LIGHTER FLUID, OR SIMILAR LIQUIDS OR AEROSOLS TO START A FIRE IN THIS INSERT. KEEP ALL SUCH LIQUIDS OR AEROSOLS WELL AWAY FROM THE INSERT WHILE IT IS IN USE.**
- Do not store fuel within heater minimum installation clearances.
- Burn only seasoned natural firewood.
- **DO NOT BURN:**
  - **GARBAGE OF ANY KIND,**
  - **COAL OR CHARCOAL,**
  - **TREATED, PAINTED OR COATED WOOD,**
  - **PLYWOOD OR PARTICLE BOARD,**
  - **FINE PAPER, COLORED PAPER OR CARDBOARD,**
  - **SALT WATER DRIFTWOOD,**
  - **MANUFACTURED LOGS CONTAINING WAX OR CHEMICAL ADDITIVES,**
  - **RAILROAD TIES OR**
  - **LIQUIDS SUCH AS KEROSENE OR DIESEL FUEL TO START A FIRE.**
- This appliance should always be maintained and operated in accordance with these instructions.
- Do not elevate the fire by using a grate.
- A smoke detector, a carbon monoxide detector and a fire extinguisher should be installed in the house. The location of the fire extinguisher should be known by all family members.



This product can expose you to chemicals including carbon monoxide, which is known to the State of California to cause cancer, birth defects or other reproductive harm. For more information go to [www.P65warnings.ca.gov/](http://www.P65warnings.ca.gov/)

## 2 GENERAL INFORMATION

### 2.1 PERFORMANCES

Values are as measured per test method, except for the recommended heating area, firebox volume, maximum burn time and maximum heat output.

Models	Matrix Insert (OB02028 and OB02028K)	
Fuel type	Dry cordwood	
Recommended heating area <sup>1</sup>	500 to 2,100 ft <sup>2</sup> (47 to 195 m <sup>2</sup> )	
Nominal firebox volume	2.4 ft <sup>3</sup> (0.068 m <sup>3</sup> )	
Maximum burn time <sup>1</sup>	8 hours	
Maximum heat output (dry cordwood) <sup>2</sup>	75,000 BTU/h (22.0 kW)	
Overall heat output rate (min. to max.) <sup>2 3</sup>	14,800 BTU/h to 28,600 BTU/h (4.34 kW to 8.38 kW)	
Average overall efficiency <sup>3</sup> - Dry cordwood	69% (HHV) <sup>4</sup>	74% (LHV) <sup>5</sup>
Optimum efficiency <sup>6</sup>	77%	
Average particulate emissions rate <sup>7</sup>	1.54 g/h (EPA / CSA B415.1-10) <sup>8</sup>	
Average CO <sup>9</sup>	89.4 g/h	

<sup>1</sup> Recommended heating area and maximum burn time may vary subject to location in home, chimney draft, heat loss factors, climate, fuel type and other variables. The recommended heated area for a given appliance is defined by the manufacturer as its capacity to maintain a minimum acceptable temperature in the designated area in case of a power failure.

<sup>2</sup> The maximum heat output (dry cordwood) is based on a loading density varying between 15 lb/ft<sup>3</sup> and 20 lb/ft<sup>3</sup>. Other performances are based on a fuel load prescribed by the standard. The specified loading density varies between 7 lb/ft<sup>3</sup> and 12 lb/ft<sup>3</sup>. The moisture content is between 19% and 25%.

<sup>3</sup> As measured per CSA B415.1-10 stack loss method.

<sup>4</sup> Higher Heating Value of the fuel.

<sup>5</sup> Lower Heating Value of the fuel.

<sup>6</sup> Optimum overall efficiency at a specific burn rate (LHV).

<sup>7</sup> This appliance is officially tested and certified by an independent agency.

<sup>8</sup> Tested and certified in compliance with CFR 40 part 60, subpart AAA, section 60.534(a)(1(ii) and Draft ASTM WK47329-14.

<sup>9</sup> Carbon monoxide.



## 2.2 SPECIFICATIONS

Maximum log length <sup>1</sup>	20 in (508 mm) east-west
Flue outlet diameter	6 in (152 mm)
Recommended connector pipe diameter	6 in (152 mm)
Type of chimney	ULC-S635, CAN/ULC-S640, UL1777
Baffle material	C-Cast
Approved for alcove installation	Not approved
Approved for mobile home installation <sup>2</sup>	Not approved
Shipping weight (without option)	484 lb (220 kg)
Appliance weight (without option)	428 lb (194 kg)
Type of door	Single, glass with cast iron frame
Type of glass	Ceramic glass
Blower	Included (up to 90 CFM)
Particulate emission standard	EPA / CSA B415.1-10 <sup>3</sup>
USA standard (safety)	UL 1482, UL 737
Canadian standard (safety)	ULC S628

- 1 East-west: through the door you see the longitudinal sides of the logs; north-south: through the door you see the tips of the logs.
- 2 Mobile home (Canada) or manufactured home (USA): The US department of Housing and Urban Development describes “manufactured homes” better known as “mobile homes” as followed; buildings built on fixed wheels and those transported on temporary wheels/axles and set on a permanent foundation. In Canada, a mobile home is a dwelling for which the manufacture and assembly of each component is completed or substantially completed prior to being moved to a site for installation on a foundation and connection to service facilities and which conforms to the CAN/CSA-Z240 MH standard.
- 3 Tested and certified in compliance with CFR 40 part 60, subpart AAA, section 60.534(a)(1)(ii) and Draft ASTM WK47329-14.

### 2.3 DIMENSIONS

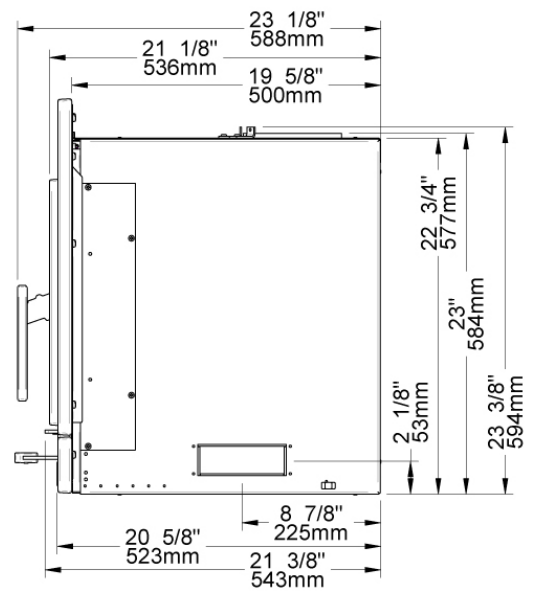
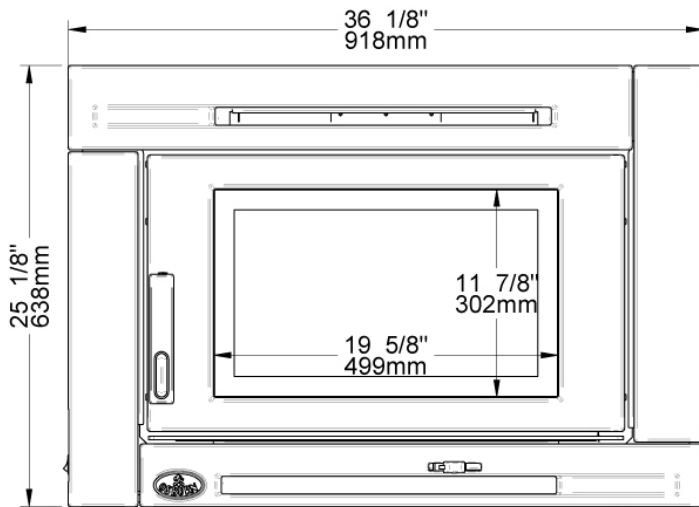
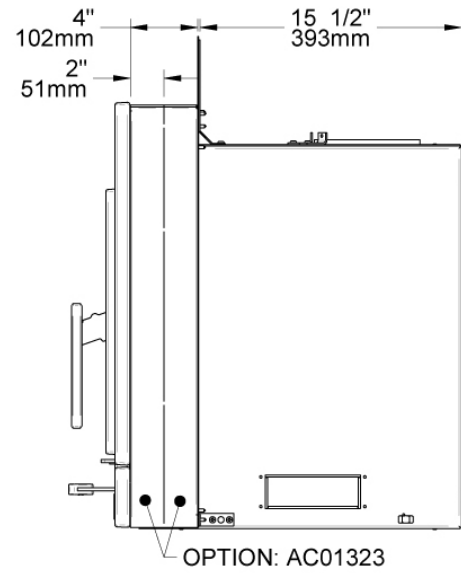
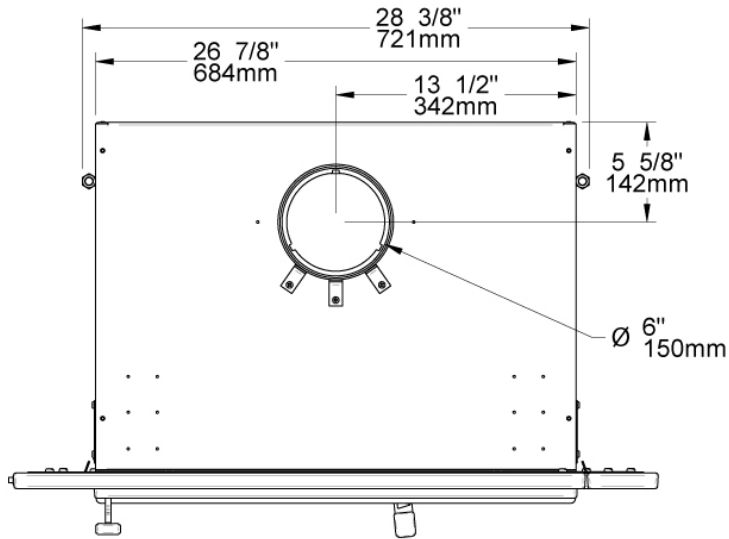

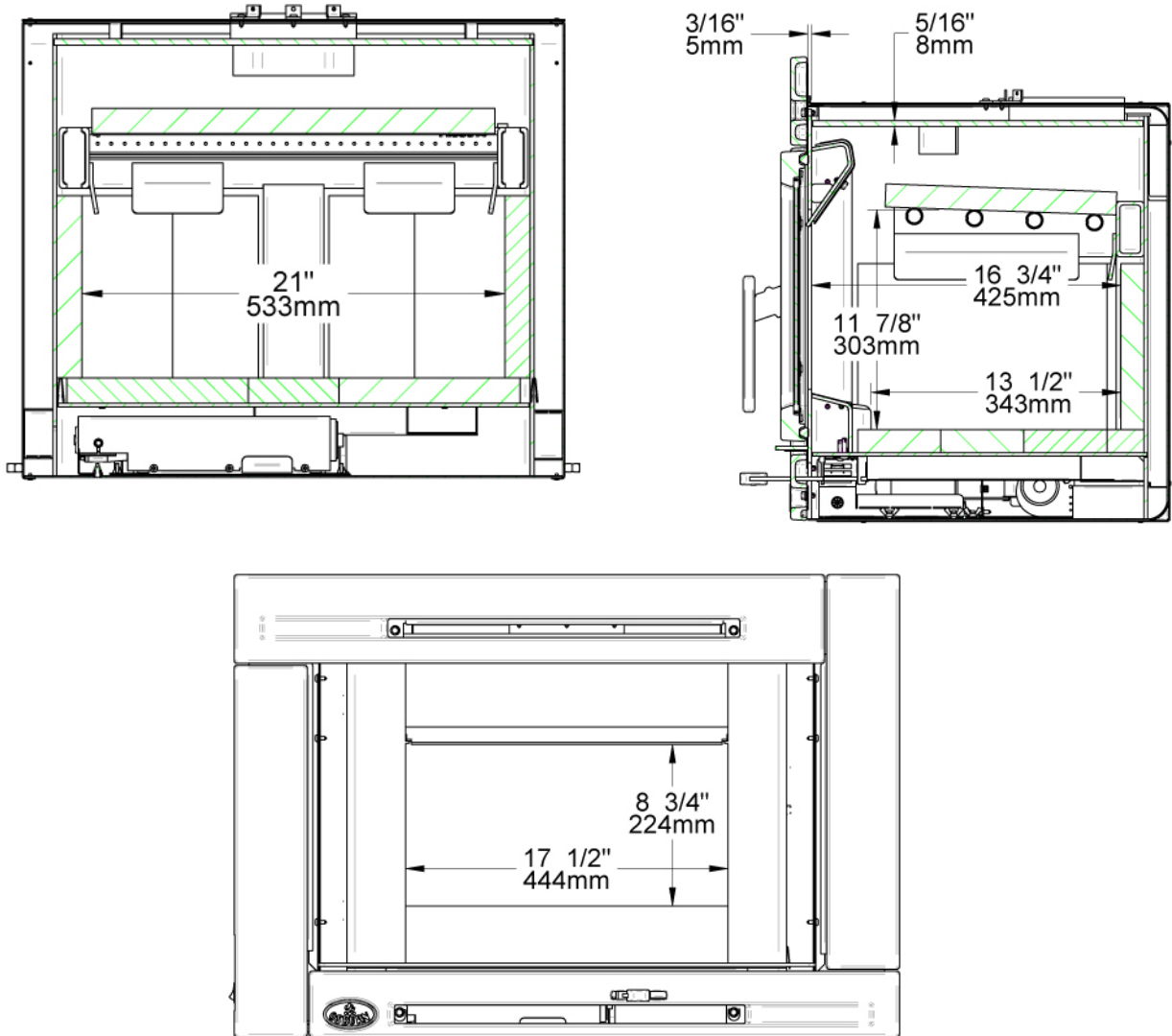

## 2.4 ZONE HEATING AND HOW TO MAKE IT WORK

Your new Matrix wood insert is a space heater, which means it is intended to heat the area it is installed in, as well as spaces that connect to that area, although to a lower temperature. This is called zone heating and it is an increasingly popular way to heat homes or spaces within homes.

Zone heating can be used to supplement another heating system by heating a particular space within a home, such as a basement family room or an addition that lacks another heat source.

Houses of moderate size and relatively new construction can be heated with a properly sized and located wood insert. Whole house zone heating works best when the insert is located in the part of the house where the family spends most of its time. This is normally the main living area where the kitchen, dining and living rooms are located. By locating the insert in this area, you will get the maximum benefit of the heat it produces and will achieve the highest possible heating efficiency and comfort.

The space where you spend most of your time will be warmest, while bedrooms and basement (if there is one) will stay cooler. In this way, you will burn less wood than with other forms of heating.

Although the insert may be able to heat the main living areas of your house to an adequate temperature, we strongly recommend that you also have a conventional oil, gas or electric heating system to provide backup heating.

Your success with zone heating will depend on several factors, including the correct sizing and location of the insert, the size, layout and age of your home and your climate zone. Three-season vacation homes can usually be heated with smaller inserts than houses that are heated all winter.

## **2.5 THE BENEFITS OF LOW EMISSIONS AND HIGH EFFICIENCY**

The low smoke emissions produced by the special features inside the Matrix insert mean that your household will release up to 90 percent less smoke into the outside environment than if you used an older conventional insert. But there is more to the emission control technologies than protecting the environment.

The smoke released from wood when it is heated contains about half of the energy content of the fuel. By burning the wood completely, your insert releases all the heat energy from the wood instead of wasting it as smoke up the chimney. Also, the features inside the firebox allow you to reduce the air supply to control heat output, while maintaining clean and efficient flaming combustion, which boosts the efficient delivery of heat to your home.

The emission control and advanced combustion features of your insert can only work properly if your fuel is in the correct moisture content range of 15 to 20 percent. See Section 3.0 of this manual for suggestions on preparing fuelwood and judging its moisture.

## **2.6 THE SBI COMMITMENT**

The SBI team is committed to protecting the environment, so we do everything we can to use only materials in our products that will have no lasting negative impact on the environment.

### **2.6.1 WHAT IS YOUR NEW INSERT MADE OF?**

The body of your insert, which is most of its weight, is carbon steel. Should it ever become necessary many years in the future, almost the entire insert can be recycled into new products, thus eliminating the need to mine new materials.

The paint coating on your insert is very thin. Its VOC content (Volatile Organic Compounds) is very low. VOCs can be responsible for smog, so all the paint used during the manufacturing process meets the latest air quality requirements regarding VOC reduction or elimination.

The air tubes are stainless steel, which can also be recycled.

The C-Cast baffle is made of an aluminosilicate fibre material that is compressed with a binder to form a rigid board. C-Cast can withstand temperatures above 2,000 °F. It is not considered hazardous waste. Disposal at a landfill is recommended.

Firebrick is mainly composed of silicon dioxide, also known as silica, a product processed from a mined mineral. It is most commonly found in nature in the form of sand and clay. Disposal at a landfill is recommended.

The door and glass gaskets are fiberglass which is spun from melted sand. Black gaskets have been dipped into a solvent-free solution. Disposal at a landfill is recommended.

The door glass is a 4 mm thick ceramic material that contains no toxic chemicals. It is made of natural raw materials such as sand and quartz that are combined in such a way to form a high temperature glass. Ceramic glass cannot be recycled in the same way as normal glass, so it should not be disposed of with your regular household products. Disposal at a landfill is recommended.

### **3 FUEL**

#### **DO NOT BURN:**

- **GARBAGE OF ANY KIND,**
- **COAL OR CHARCOAL,**
- **TREATED, PAINTED OR COATED WOOD,**
- **PLYWOOD OR PARTICLE BOARD,**
- **FINE PAPER, COLORED PAPER OR CARDBOARD,**
- **SALT WATER DRIFTWOOD,**
- **MANUFACTURED LOGS CONTAINING WAX OR CHEMICAL ADDITIVES,**
- **RAILROAD TIES AND**
- **LIQUIDS SUCH AS KEROSENE OR DIESEL FUEL TO START A FIRE.**

#### **3.1 HOW TO PREPARE OR BUY GOOD FIREWOOD**

##### **3.1.1 WHAT IS GOOD FIREWOOD?**

Good firewood has been cut to the correct length for the insert, split to a range of sizes and stacked in the open until its moisture content is reduced to 15% to 20%.

##### **3.1.2 TREE SPECIES**

The tree species the firewood is produced from is less important than its moisture content. The main difference in firewood from various tree species is the density of the wood. Hardwoods are denser than softwoods. People who live in the coldest regions of North America usually have only spruce, birch and poplar, other low-density species to burn and yet they can heat their homes successfully.

Homeowners with access to both hardwood and softwood fuel sometimes use both types for different purposes. For example, softer woods make good fuel for relatively mild weather in spring and fall because they light quickly and produce less heat. Softwoods are not as dense as hardwoods so a given volume of wood contains less energy. Using softwoods avoids overheating the house, which can be a common problem with wood heating in moderate weather. Harder woods are best for colder winter weather when more heat and longer burn cycles are desirable.

Note that hardwood trees like oak, maple, ash and beech are slower growing and longer lived than softer woods like poplar and birch. That makes hardwood trees more valuable. The advice that only hardwoods are good to burn is outdated.

Old, leaky cast iron stoves wouldn't hold a fire overnight unless they were fed large pieces of hardwood. That is no longer true. You can successfully heat your home by using the less desirable tree species and give the forest a break at the same time.

### 3.1.3 LOG LENGTH

Logs should be cut at least 1" (25 mm) shorter than the firebox so they fit in easily. Pieces that are even slightly too long make loading the insert very difficult. The most common standard length of firewood is 16" (400 mm).

The pieces should be a consistent length, with a maximum of 1" (25 mm) variation from piece to piece.

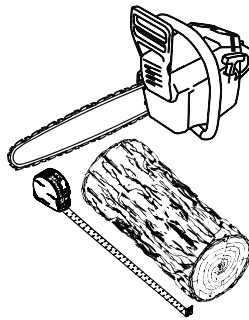

### 3.1.4 PIECE SIZE

Firewood dries more quickly when it is split. Large unsplit rounds can take years to dry enough to burn. Even when dried, unsplit logs are difficult to ignite because they don't have the sharp edges where the flames first catch. Logs as small as 3" (75 mm) should be split to encourage drying.

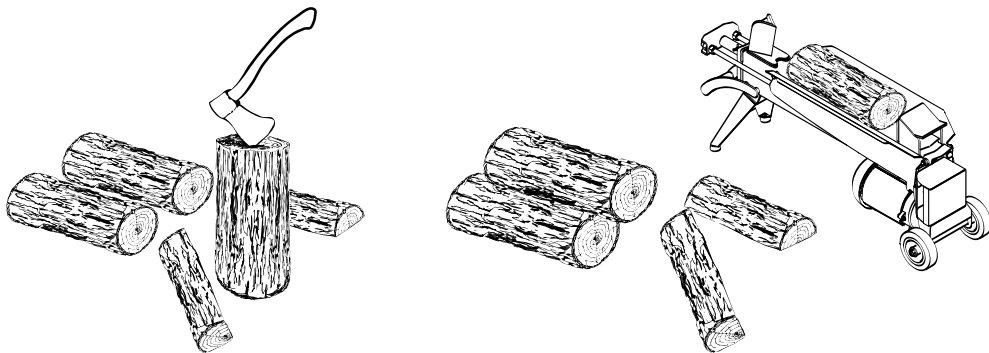

Wood should be split to a range of sizes, from about 3" to 6" (75 mm to 150 mm) in cross section. Having a range of sizes makes starting and rekindling fires much easier. Often, the firewood purchased from commercial suppliers is not split finely enough for convenient stoking. It is sometimes advisable to resplit the wood before stacking to dry.

### 3.1.5 HOW TO DRY FIREWOOD

Firewood that is not dry enough to burn is the cause of most complaints about wood inserts. Continually burning green or unseasoned wood produces more creosote and involves lack of heat and dirty glass door.

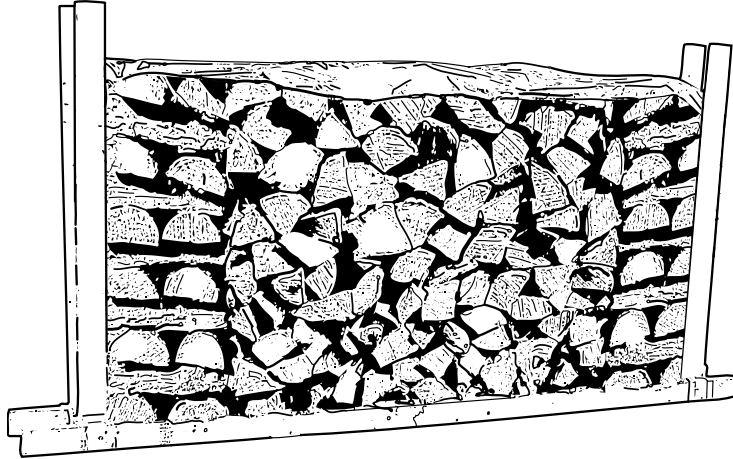

Here are some things to consider in estimating drying time:

- Firewood takes a long time to dry.
- Firewood bought from a dealer is rarely dry enough to burn, so it is advisable to buy the wood in spring and dry it yourself.
- Drying happens faster in dry weather than in damp, maritime climates.
- Drying happens faster in warm summer weather than in winter weather.
- Small pieces dry more quickly than large pieces.
- Split pieces dry more quickly than unsplit rounds.
- Softwoods take less time to dry than hardwoods.
- Softwoods like pine, spruce, and poplar/aspen can be dry enough to burn after being stacked in the open for only the summer months.
- Hardwoods like oak, maple and ash can take one, or even two years to dry fully, especially if the pieces are big.
- Firewood dries more quickly when stacked in the open where it is exposed to sun and wind; it takes much longer to dry when stacked in a wood shed.
- Firewood that is ready to burn has a moisture content between 15 and 20% by weight and will allow your insert to produce its highest possible efficiency.

### 3.1.6 JUDGING FIREWOOD MOISTURE CONTENT

You can find out if some firewood is dry enough to burn by using these guidelines:

- Cracks form at the ends of logs as they dry.
- As it dries in the sun, the wood turns from white or cream colored to grey or yellow.
- Bang two pieces of wood together; seasoned wood sounds hollow and wet wood sounds dull.
- Dry wood is much lighter in weight than wet wood.
- Split a piece, and if the fresh face feels warm and dry it is dry enough to burn; if it feels damp, it is too wet.
- Burn a piece; wet wood hisses and sizzles in the fire and dry wood does not.

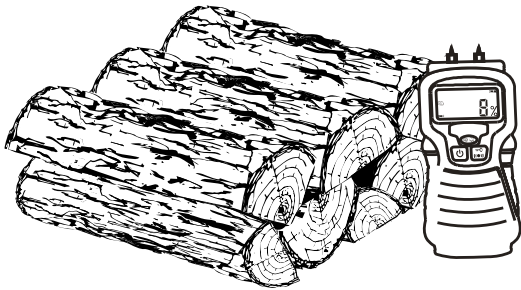

A wood moisture meter can be bought to test the firewood.

### 3.2 MANUFACTURED LOGS

Do not burn manufactured logs made of wax impregnated sawdust or logs with any chemical additives. Manufactured logs made of 100% compressed sawdust can be burned, but use caution in the number of these logs burned at one time. Start with one manufactured log and see how the insert reacts. Never use more than two manufactured logs.

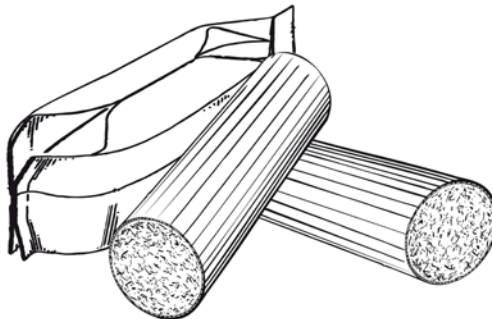



## 4 OPERATING THE INSERT

### 4.1 BEFORE OPERATING THE INSERT

If necessary, before using the insert, the following step should be completed:

- Install the fresh air inlet (see "Appendix 3: Installing the optional air inlet");
- Install the faceplate backing plate (see the faceplate installation instructions for more details);
- Install the projection kit (see the projection kit installation instructions for more details);

### 4.2 THE USE OF A FIRE SCREEN.

This insert has been tested for use with an open door in conjunction with a fire screen, sold separately. Make sure the fire screen is properly secured on the insert to avoid any risk of sparks damaging your flooring. When the fire screen is in use, do not leave the insert unattended so that you can respond promptly in the event of smoke spillage into the room. Potential causes of smoke spillage are described in **Section 10 The Venting System** of this manual. See **Appendix 2: Installing the Fire Screen** for installation instructions.

**OPERATING WITH THE FIRE SCREEN INCREASES POSSIBILITIES OF GENERATING CARBON MONOXIDE. CARBON MONOXIDE IS AN ODOURLESS GAS THAT IS HIGHLY TOXIC AND WHICH CAN CAUSE DEATH AT HIGH CONCENTRATION IN AIR.**

### 4.3 BLOWER OPERATION

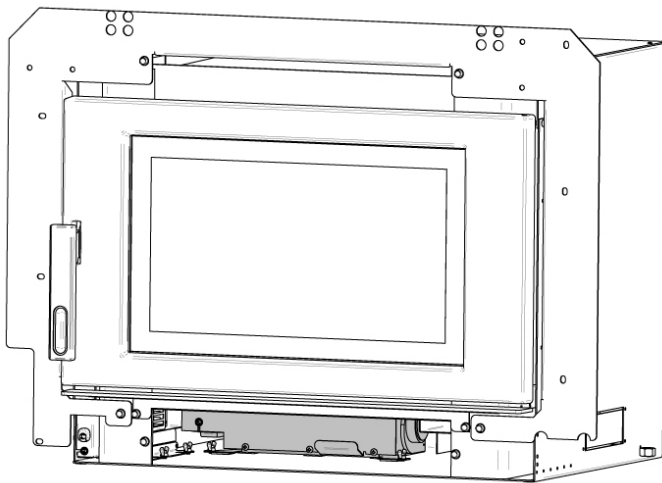

A blower is already installed on this insert. It is located underneath the insert, behind the bottom faceplate. Its function is to increase airflow through the heat exchanger and improve hot air circulation in the room. When used regularly, the blower can provide a small increase in efficiency, up to 2%. However, the use of a blower should not be used as a way to gain more output from an insert that is undersized for the space it is intended to heat.

**Ensure the blower cord is not in contact with any surface of the insert to prevent electrical shock or fire damage. Do not run cord beneath the insert.**

Allow the insert to reach operating temperature (approximately one hour) before turning on the blower, since increased airflow from the blower will remove heat and affect the start up combustion efficiency.

The insert's blower assembly is equipped with a heat sensor. Therefore, you can leave the switch in the automatic position (3). The blower will start automatically when the insert is hot enough and it will stop when the insert has cooled down. You can also set the switch to the manual position (1) to operate the blower at any time. Select the position (2) to manually stop the blower.

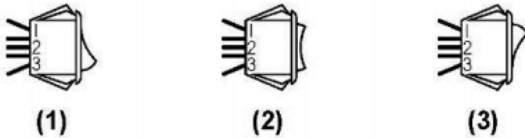
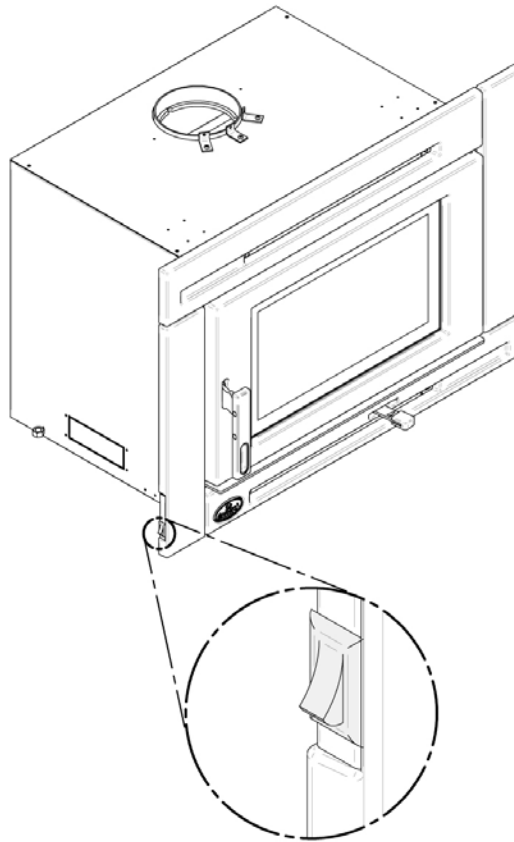

## 5 BURNING WOOD EFFICIENTLY

### 5.1 THE FIRST FIRES

Two things will happen as you burn your first few fires; the paint cures and the internal components of the insert are conditioned.

As the paint cures, some of the chemicals vaporize. The vapors are not poisonous, but they do smell bad. Fresh paint fumes can also cause false alarms in smoke detectors. So, when you first light your insert, be prepared by opening doors and/or windows to ventilate the house. As you burn hotter and hotter fires, more of the painted surfaces reach the curing temperature of the paint. The smell of curing paint does not disappear until you have burned one or two very hot fires.

Burn one or two small fires to begin the curing and conditioning process. Then build bigger and hotter fires until there is no longer any paint smell from the insert. Once the paint smell disappears, your insert is ready for serious heating.

## 5.2 LIGHTING FIRES

Each person who heats with wood develops their own favorite way to light fires. Whatever method you choose, your goal should be to get a hot fire burning quickly. A fire that starts fast produces less smoke and deposits less creosote in the chimney. Here are three popular and effective ways to start wood fires.

### 5.2.1 CONVENTIONAL METHOD

The conventional way to build a wood fire is to bunch up 5 to 10 sheets of newspaper and place them in the firebox. Next, a dozen pieces of fine kindling are placed on the newspaper. This kindling should be very thin; less than 1 inch thick (25 mm). Then, larger kindling pieces are placed on the fine kindling. The air control fully open, the newspaper is lit. With a tall and straight venting system the door can be closed immediately, and the fire will ignite. Once the fire has ignited, the door can be closed with the air control still fully open. When the kindling is almost completely burned, standard firewood pieces can be added until the fire is the right size for the weather.

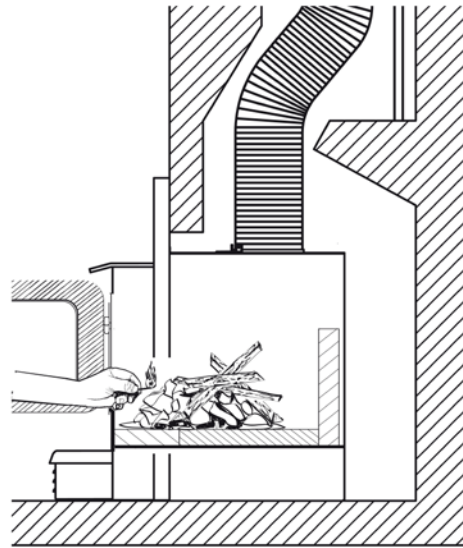

**DO NOT LEAVE THE INSERT UNATTENDED WHEN THE DOOR IS SLIGHTLY OPENED. ALWAYS CLOSE AND LATCH THE DOOR AFTER THE FIRE IGNITES.**

After the kindling fire has mostly burned, you can add standard firewood pieces until you have a fire of the right size for the conditions.

### 5.2.2 THE TOP DOWN METHOD

The top down method solves two problems encountered when using the conventional method: first, the fire does not collapse on itself and smother as it burns; and second, it is not necessary to build up the fire gradually since the firebox is loaded before the fire is lit. A top down fire can burn for two hours or more. The top down method works properly only if well-seasoned wood is used.

Three or four full-sized split pieces of dry firewood are placed in the firebox. Then, 4 or 5 more finely split pieces of firewood (2" to 3" [50 mm to 75 mm] in diameter) are placed on the top of the logs at right angles (log cabin style). Next, a dozen finely split kindling are placed on the second layer at right angles.

The fire is topped with 5 sheets of newspaper, stuffed in between the kindling, under the baffle. Knots can be made in the newspaper by rolling up single sheets corner to corner and tying a knot in them. The advantage of knots is that they don't roll off the fire as they burn. Newspaper is lit and the fire burns from top to bottom.

### **5.2.3 TWO PARALLEL LOGS METHOD**

Two spit logs are placed in the firebox with a few sheets of twisted newspapers in between the logs. Fine kindling is added across the two logs and some larger kindling across those, log cabin style. Newspaper is lit.

### **5.2.4 USING FIRE STARTERS**

Commercial fire starters can be used instead of a newspaper. Some of these starters are made of sawdust and wax and others are made of specialized flammable solid chemicals. Always follow the package directions when using.

Gel starters can also be used, but only to light a fire, in a cold combustion chamber without hot embers inside.

**DO NOT USE FLAMMABLE LIQUIDS SUCH AS GASOLINE, NAPHTHA, FUEL OIL, MOTOR OIL, OR AEROSOLS TO START OR REKINDLE THE FIRE.**

## **5.3 MAINTAINING WOOD FIRES**

### **5.3.1 GENERAL ADVICE**

Wood heating with a space heater is very different than other forms of heating. There will be temperature variations in different parts of the house and there will be temperature variations throughout day and night. This is normal, and for experienced wood burners these are advantages of zone heating woodburning.

Wood inserts don't have a steady heat output. It is normal for the temperature to rise after a new load of wood is ignited and for its temperature to gradually decrease throughout the burning cycle. This increasing and decreasing temperature can be matched with the household routines. For example, the temperature in the area can be cooler when the household is active, and it can be warmer when it is inactive.

Wood burns best in cycles. A cycle starts when a new load of wood is ignited by hot coals and ends when that load has been consumed down to a bed of charcoal about the same size as it was when the wood was loaded. Trying to produce a steady heat output by placing a single log on the fire at regular intervals is not recommended. Always place at least three, and preferably more pieces on the fire at a time so that the heat radiated from one piece helps to ignite the pieces next to it. Each load of wood should provide several hours of heating. The size of each load may vary depending on the amount of heat required.

Burning in cycles means the insert door does not need to be opened while the wood is flaming. This is an advantage since it is preventing smoke leaking from the insert when the door is opened as a full fire is burning. This is especially true if the chimney is on the outside wall of the house.

**IF THE DOOR MUST BE OPENED WHILE THE FIRE IS FLAMING, FULLY OPEN AIR CONTROL FOR A FEW MINUTES THEN OPEN THE DOOR SLOWLY.**

### 5.3.2 ASH REMOVAL

Ash should be removed from the firebox every two or three days of full time heating. Do not let the ash build up in the firebox because it will interfere with proper fire management.

The best time to remove ash is after an overnight fire when the insert is relatively cool, but there is still some chimney draft to draw the ash dust into the insert and prevent it from coming into the room.

After ashes have been removed from the insert and placed in a tightly covered metal container, they should be taken outside immediately. The closed container of ashes should be placed on a non-combustible floor or on the ground well away from all combustible materials pending final disposal. Ashes normally contain some live charcoal that can stay hot for several days. If the ashes are disposed of by burial in soil or otherwise locally dispersed, they should be retained in the closed container until all cinders have thoroughly cooled. Other waste should not be placed in this container.

**NEVER STORE ASHES INDOORS OR IN A NON-METALIC CONTAINER OR ON A WOODEN DECK.**

### 5.3.3 RAKING CHARCOAL

When the room temperature is cooler, it is time to reload the insert. Remove the ashes first, then rake charcoal towards the front of the firebox before reloading. Most of the remaining charcoal will be at the back of the firebox, furthest from the door. Rake the coals towards the door before loading

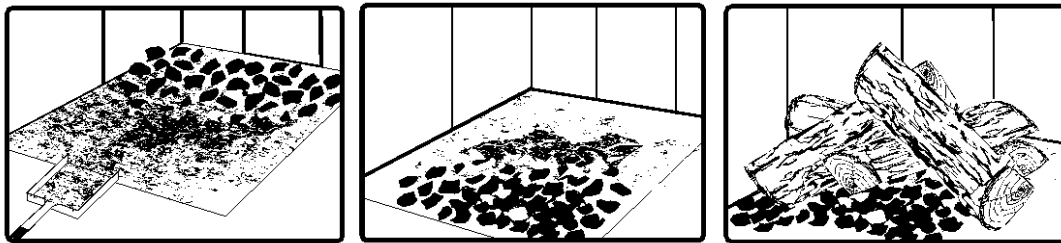

Raking the coals is useful for two reasons. First, it brings them near where most of the combustion air enters the firebox. This will ignite the new load quickly. Secondly, the charcoal will not be smothered by the new load of wood. When the embers are simply spread inside the combustion chamber, the new load smoulder for a long time before igniting.

### 5.3.4 FIRING EACH NEW LOAD HOT

Place the new load of wood on and behind the charcoal. Close the door and open the air control fully until the firebox is full of flames, the wood has charred to black and its edges are glowing red. Firing each load of wood hot accomplishes the following things:

- Removes surface moisture from the wood,
- Creates a layer of char on the wood, which slows down the smoke release,
- Heats the firebox components so they reflect heat back to the fire, and
- Heats the chimney so it can produce strong, steady draft for the rest of the cycle.

Although it is important to fire each new load hot, **do not allow the fire to burn at full intensity for more than a few minutes.**

**DO NOT LEAVE THE INSERT UNATTENDED WHILE A NEW LOAD IS BEING FIRED HOT.**

**DO NOT OVERFIRE.**

When a new load of wood is ignited, there will be a surge of heat from the insert. This heat surge is welcome when the room temperature is a little lower than desirable, but not welcome if the space is already warm. Therefore, each load of wood should burn completely so that the space begins to cool off a little before loading. Letting the space cool before loading is one of the secrets to clean burning and effective zone heating.

### 5.3.5 CONTROLLING THE AIR INTAKE

Once the firewood, firebox and chimney are hot, you can begin to reduce the air supply for a steady burn.

As the air intake is reduced, the burn rate decreases. This has the effect of distributing the thermal energy of the fuel over a longer period of time. In addition, the flow rate of exhaust through the insert and flue pipe slows down, which increases the duration of the energy transfer of the exhaust gases. As the air intake is reduced, the flame slows down.

If the flames diminish to the point of disappearing, the air intake has been reduced too early in the combustion cycle or the wood used is too wet. If the wood is dry and the air control is used properly, the flames should decrease, but remain bright and stable.

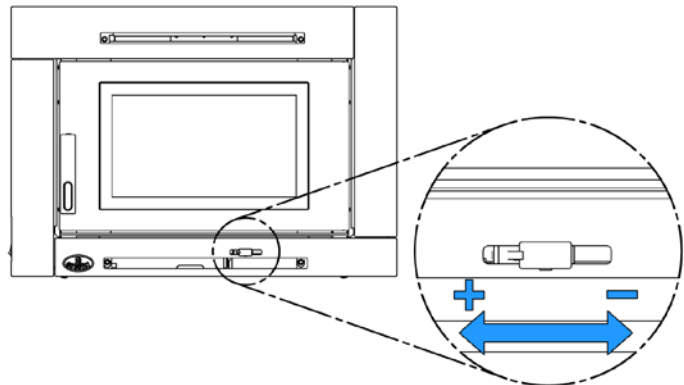

## 5.4 FIRE TYPES

Using the air intake control is not the only way to match the insert heat output to the desired temperature in the house. A house will need far less heating in October than in January to maintain a comfortable temperature. Filling the firebox full in fall weather will overheat the space. Otherwise, the combustion rate will have to be reduced to a minimum and the fire will be smoky and inefficient. Here are some suggestions for building fires suitable for different heating needs.

### 5.4.1 SMALL FIRES TO TAKE THE CHILL OFF THE HOUSE

To build a small fire that will produce a low heat output, use small pieces of firewood and load them crisscross in the firebox. The pieces should only be 3" to 4" in diameter. After raking the coals, lay two pieces parallel to each other diagonally in the firebox and lay two more across them in the other direction. Open the air control fully and only reduce the air after the wood is fully flaming.

This kind of fire is good for mild weather and should provide enough heat for up to four hours. Small fires like this are a good time to use softer wood species and avoid overheating the house.

**5.4.2 LONG LASTING LOW OUTPUT FIRES**

For a fire that will last up to eight hours but will not produce intense heat, use soft wood and place the logs compactly in the firebox. Before reducing the air intake, the load will have to burn at full heat for long enough for charring the surface of the logs. The flame must be bright before letting the fire burn by itself.

**5.4.3 HIGH OUTPUT FIRES FOR COLD WEATHER**

When heating needs are high during cold weather, the fire should burn steadily and brightly. This is the time to use larger pieces of hardwood. Place the biggest pieces at the back of the firebox and place the rest of the pieces compactly. A densely built fire like this will produce the longest combustion this insert is capable of.

Special attention must be paid when building fires like this since if the air intake is reduced too quickly, the fire could smoulder. The wood must be flaming brightly before leaving the fire to burn.

**5.4.4 MAXIMUM BURN CYCLE TIMES**

The burn cycle time is the period between loading wood on a coal bed and the consumption of that wood back to a coal bed of the same size. The flaming phase of the fire lasts for roughly the first half of the burn cycle and the second half is the coal bed phase during which there is little or no flame. The length of burn you can expect from your insert, including both the flaming and coal bed phases, will be affected by a number of things, such as:

- Firebox size
- The amount of wood loaded
- The species of wood you burn
- The wood moisture content
- The size of the space to be heated
- The climate zone you live in
- The time of year

The table below gives an approximate maximum burn cycle times, based on firebox volume.

**Table 1: Approximate Maximum Burn Cycle Time**

<b>FIREBOX VOLUME</b>	<b>MAXIMUM BURN TIME</b>
<1.5 cubic feet	3 to 5 hours
1.5 c.f. to 2.0 c.f.	5 to 6 hours
2.0 c.f. to 2.5 c.f.	6 to 8 hours
2.5 c.f. to 3.0 c.f.	8 to 9 hours
>3.0 c.f.	9 to 10 hours

A longer burning time is not necessarily an indication of efficient insert operation. It is preferable to build a smaller fire that will provide three or four hours of heating than to fully load the firebox for a much longer burn. Shorter burn cycles make it easier to match the heat output of the insert to the heat demand of the space.

### 5.4.5 LOGS ORIENTATION

In a relatively square firebox, the wood can be loaded north-south (ends of the logs visible) or east-west (sides of the logs visible).

North-south loads allow more wood to be loaded at the same time. On the other hand, they break into smaller pieces faster. North-south loading is good for high output, long lasting fires for cold weather.

East-west loads allow a limited amount of wood since too many logs could cause them to fall on the glass. East-west loads, placed in a compact way, take a long time before breaking down. They are excellent for low-intensity, long-lasting fires in relatively mild weather.

## 6 MAINTAINING THE WOOD HEATING SYSTEM

### 6.1 INSERT MAINTENANCE

This insert will give many years of reliable service if used and maintained properly. Some of the internal components of the firebox, such as firebricks, baffle and air tubes will wear over time under intense heat. Defective parts should always be replaced with original parts. See «**Appendix 7: Exploded Diagram and Parts List**». Firing each load hot to begin a cycle as described above will not cause premature deterioration of the insert. However, letting the insert run with the air intake fully open for entire burn cycles can cause damage over time. The hotter the insert becomes throughout burn cycles, the more quickly its components will deteriorate. For this reason, **the insert should never be left unattended while a new load is being fired hot.**

#### 6.1.1 CLEANING DOOR GLASS

Under normal conditions, your door glass should stay relatively clear. If your firewood is dry enough and you follow the operating instructions in this manual, a whitish, dusty deposit will form on the inside of the glass after a week or so of use. This is normal and can be easily removed when the insert is cool by wiping with a damp cloth or paper towel and then drying. **Never try to clean the glass when the insert is hot.**

In spring and fall when the insert runs at lower temperatures, light brown stains may form, especially in the lower corners of the glass. This indicates that the fire has been smoky and some of the smoke has condensed on the glass. It also indicates incomplete combustion of the wood, which also means more smoke emissions and faster formation of creosote in the chimney. The deposits that form on the glass are the best indication of the fuel quality and success in properly using the insert.

The goal should be having a clear glass with no brown stains. If brown stains appear regularly on the glass, something about the fuel or the operating procedure needs to be changed.

These stains can be cleaned with a special wood insert glass cleaner. Do not use abrasives to clean the insert glass. When the weather is mild, it is often better to let the fire go out than trying to maintain a continuous fire. Use the technique described in section «**5.4.1 Small Fires to Take the Chill Off the House**».



When brown streaks are coming from the edge of the glass, it is time to replace the gasket around the glass. The glass gasket should be self-adhesive. Follow the instructions in section «**6.1.4 Replacing the Glass or the Glass Gasket**» for installation. Always replace gaskets with genuine ones. See «**Appendix 7: Exploded Diagram and Parts List**».

**Do not abuse the glass door by striking or slamming shut. Do not use the insert if the glass is broken.**

### 6.1.2 DOOR ADJUSTMENT

In order for the insert to burn at its best efficiency, the door must provide a perfect seal with the firebox. Therefore, the gasket should be inspected periodically to insure a good seal. The gasket seal may be improved with a simple latch mechanism adjustment. To adjust the pressure on the seal, unscrew the top and bottom bolts and move the plate forward or backward. To adjust the angle of the door handle, unscrew the left and right bolts and raise or lower the mechanism.

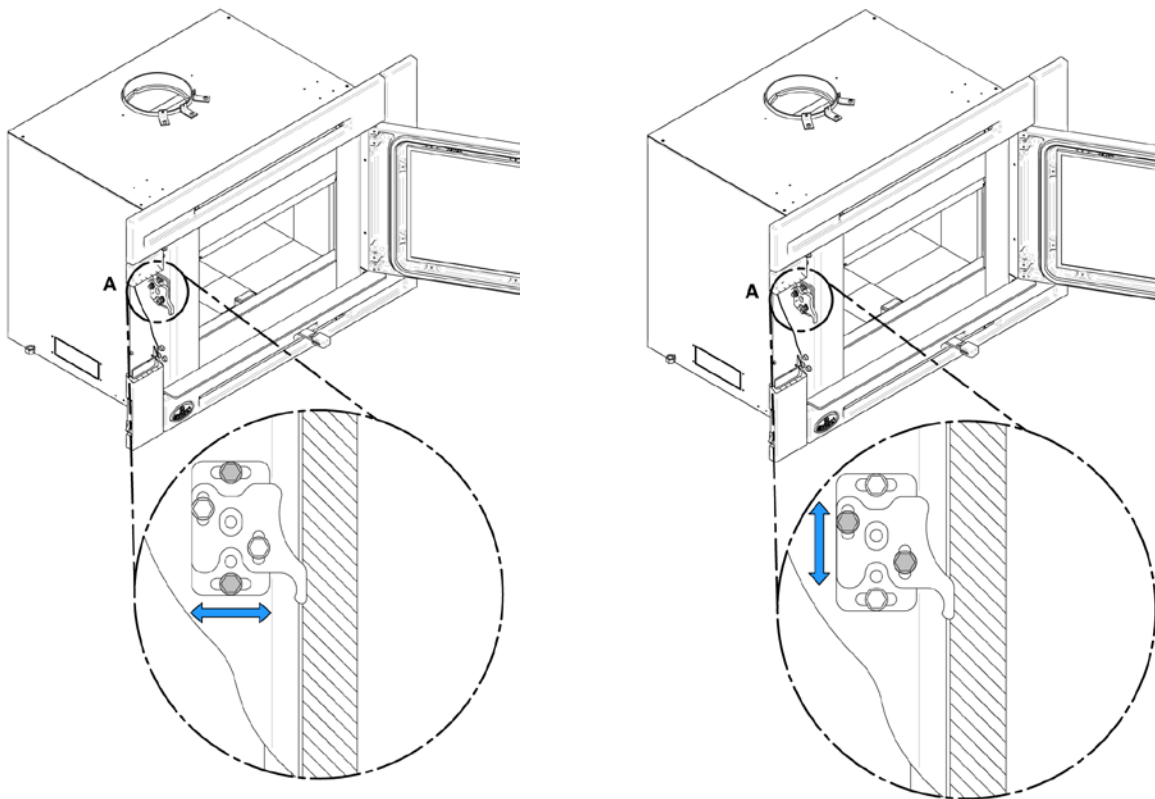

### 6.1.3 REPLACING THE DOOR GASKET

It is important to maintain the gasket in good condition. After a year or more of use, the door gasket will compress and become hard, which may allow air to leak. The condition of the door seal can be verified by closing and latching the door on a strip of paper. The test must be performed all around the door. If the paper slips out easily anywhere, it is time to replace the gasket.

It is important to replace the gasket with another having the same diameter and density to maintain a good seal

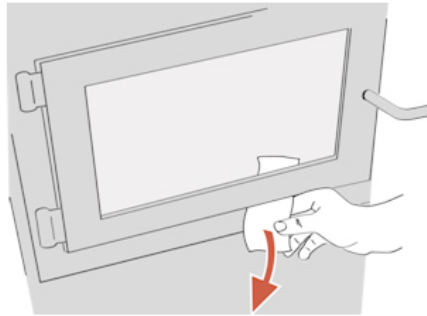

Remove the door and place it face-down on something soft like a cushion of rags or a piece of carpet. Remove the old gasket from the door by pulling and prying it out with an old screw driver. Then use the screwdriver to scrape the old gasket adhesive from the door gasket groove. Apply a bead of approximately  $\frac{1}{4}$ " (6 mm) of high temperature silicone in the door gasket groove. Starting from the middle, hinges side, press the gasket into the groove. The gasket must not be stretched during installation. Leave about  $\frac{1}{2}$ " long of gasket when cutting and press the end into the groove. Tuck any loose fibers under the gasket and into the silicone. Close the door. Do not use the insert for 24 hours.

#### 6.1.4 REPLACING THE GLASS OR THE GLASS GASKET

It is a good idea to replace the glass gasket when the door gasket is replaced. The gasket is flat, adhesive-backed, woven fiberglass. Remove the glass retaining screws (A) and clips (B) then both metal frames (C) that holds the glass to the door frame (E). Lift out the glass (D) and pull off the old gasket. This is a good time to clean the glass thoroughly. **The two main causes of broken glass door are uneven placement in the door and over-tightening the retaining screws.**

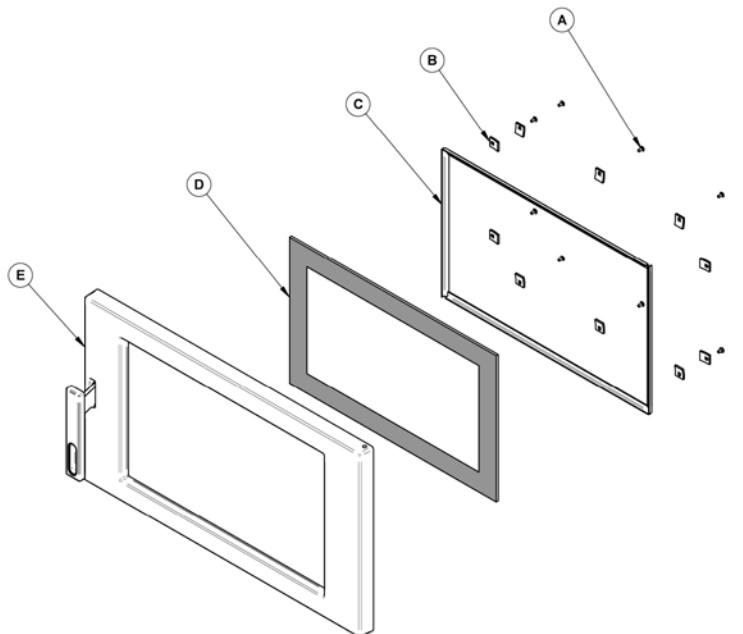

It is a good idea to replace the glass gasket when the door gasket is being replaced. Follow the previous steps to remove the glass. Remove the old gasket and clean the glass thoroughly. The new gasket is flat, adhesive-backed, woven fiberglass.

The gasket must be centered on the edge of the glass. To do this easily, peel back a section of the paper covering the adhesive and place the gasket on a table with the adhesive side up. Stick the end of the gasket to the middle of one edge, then press the edge of the glass down onto the gasket, taking care that it is perfectly centered on the gasket. Peel off more of the backing and rotate the glass. The gasket must not be stretched during installation. Cut the gasket to the required length. Pinch the gasket onto the glass in a U shape, all around the glass.



**Do not abuse the glass door by striking or slamming shut. Do not use the insert if the glass is broken.**

#### 6.1.5 CLEANING AND PAINTING THE INSERT

Painted and plated surfaces can be wiped down with a soft, damp cloth. If the paint is scratched or damaged, it is possible to repaint the insert with a heat-resistant paint. **Do not clean or paint the insert when it is hot.** Before painting, the surface should be sanded lightly with sandpaper and then wiped off to remove dust. Apply two thin layers of paint. For best results, use the original paint, available in aerosol cans.

#### 6.1.6 FIREBRICKS

Before installing the firebrick, ensure that none are broken or damaged in any way, and replace the damaged ones. Check the firebrick for damage at least annually and replace any broken or damaged ones with new ones.

### 6.2 CHIMNEY MAINTENANCE

#### 6.2.1 WHY CHIMNEY CLEANING IS NECESSARY?

Wood smoke can condense inside the chimney, forming a flammable deposit called creosote. If creosote is allowed to build up in the venting system it can ignite when a hot fire is burned in the insert and a very hot fire can progress to the top of the chimney. Severe chimney fires can damage even the best chimneys. Smouldering, smoky fires can quickly cause a thick layer of creosote to form. When the insert is operated properly, the exhaust from the chimney is mostly clear and creosote builds up more slowly.

#### 6.2.2 HOW OFTEN SHOULD THE CHIMNEY BE CLEANED?

It is not possible to predict how much or how quickly creosote will form in the chimney. It is important, therefore, to check the build-up in the chimney monthly until the rate of creosote formation is determined. Even if creosote forms slowly in the system, the chimney should be cleaned and inspected at least once each year.

Contact the local municipal or provincial fire authority for information on how to handle a chimney fire. Have a clearly understood plan to handle a chimney fire.

### 6.2.3 SWEEPING THE CHIMNEY

Chimney sweeping can be a difficult and dangerous job. People with no chimney sweeping experience will often prefer to hire a professional chimney sweep to inspect and clean the system for the first time. After seeing the cleaning process, some will choose to do it themselves.

The most common equipment used are fiberglass rods with threaded fittings and stiff plastic brushes. The brush is forced up and down inside the chimney flue to scrub off the creosote.

The chimney should be checked regularly for creosote build-up. Inspection and cleaning of the chimney can be facilitated by removing the baffle. See «**Appendix 5: Air Tubes and Baffle Installation**» for more details.



**THE OPERATION OF THIS INSERT WITHOUT THE BAFFLE MAY CAUSE UNSAFE AND HAZARDOUS TEMPERATURE CONDITIONS AND WILL VOID THE WARRANTY.**

## **PART B - INSTALLATION**

### **7 MASONRY FIREPLACE REQUIREMENTS**

The masonry fireplace must meet the minimum requirements found in the building code enforced locally, or the equivalent for a safe installation. Contact your local Building Inspector for requirements in your area. An inspection of the fireplace should include the following:

#### **CONDITION OF THE FIREPLACE AND CHIMNEY:**

- The masonry fireplace and chimney should be inspected prior to installation, to determine that they are free from cracks, loose mortar, creosote deposits, blockage, or other signs of deterioration. If evidence of deterioration is noted, the fireplace or chimney should be upgraded and/or cleaned prior to installation.
- Masonry or steel, including the damper plate, may be removed from the smoke shelf and adjacent damper frame if necessary to accommodate the insert's chimney liner, provided that their removal will not weaken the structure of the fireplace and chimney, and will not reduce protection for combustible materials to less than that required by the building code.

#### **INSTALLATION INTO AN EXISTING FACTORY-BUILT ZERO-CLEARANCE FIREPLACE:**

- It is possible to install a wood insert into an existing factory-built zero-clearance fireplace. However, there currently exists no UL or ULC standard specific to that type of installation. The factory-built zero clearance fireplace must be listed; that is, safety certified by an accredited certification agency such as UL/ULC, Omni or Intertek). It must be suitable for use with solid fuel and nothing in the owner's manual must specifically prohibit the installation of a fireplace insert. When in doubt, check with the fireplace manufacturer.
- The installation of the zero-clearance fireplace **MUST** be thoroughly inspected by a qualified person to ensure that it still meets the manufacturer's specifications. The chimney must be at least 1" (25 mm) larger in diameter than the stainless-steel liner that will run from the insert flue collar to the top of the chimney termination.
- Never remove parts intended to insulate the zero-clearance fireplace from combustible material. Only readily detachable parts that are easily replaced, such as damper parts, screens, and doors, are to be removed from the fireplace. These parts should be stored and available for reinstallation if the insert is ever removed.
- Removal of any parts which render the fireplace unfit for use with solid fuel requires the fireplace to be permanently labeled by the installer as being no longer suitable for solid fuel until the removed parts are replaced and the fireplace is restored to its original certified condition. Also, any air vents, grilles, or louvers that allow air circulation around the fireplace must not be removed or blocked.

#### **CHIMNEY CAPS:**

- Mesh type chimney caps must have provision for regular cleaning, or the mesh should be removed to eliminate the potential of plugging.

### ADJACENT COMBUSTIBLES:

- The fireplace should be inspected to make sure that there is adequate clearance to combustibles, both exposed combustibles to the top, side, and front as well as concealed combustibles, in the chimney and mantle area. Your local inspector should have information on whether older fireplaces are of adequate construction.

### OPENING SIZE:

- Refer to section «9.5 Minimum Masonry Opening and Clearances to Combustibles» for suitable size fireplace openings.

## 8 SAFETY INFORMATION AND STANDARDS

- The information given on the certification label affixed to the appliance always overrides the information published, in any other media (owner's manual, catalogues, flyers, magazines and web sites).
- Mixing of appliance components from different sources or modifying components may result in hazardous conditions. Where any such changes are planned, Stove Builder International Inc. Should be contacted in advance.
- Any modification of the appliance that has not been approved in writing by the testing authority violates CSA B365 (Canada), and ANSI NFPA 211 (USA).
- Connect this insert only to a listed stainless steel chimney liner for use with solid fuel.
- If required, a supply of combustion air shall be provided to the room.
- Do not connect to or use in conjunction with any air distribution ductwork unless specifically approved for such installation.
- Do not connect this unit to a chimney flue serving another appliance.
- The insert and its stainless steel chimney liner are to be installed only within a lined masonry chimney and masonry fireplace conforming to building codes for use with solid fuel. Do not remove bricks or mortar from the existing fireplace when installing the insert.

### 8.1 REGULATIONS COVERING INSERT INSTALLATION

When installed and operated as described in these instructions, the Matrix wood insert is suitable for use in residential installations. The Matrix wood insert is not intended for installation in a bedroom.

In Canada, the CSA B365 Installation Code for Solid Fuel Burning Appliances and Equipment and the CSA C22.1 Canadian National Electrical Code are to be followed in the absence of local code requirements. In the USA, the ANSI NFPA 211 Standard for Chimneys, Fireplaces, Vents and Solid Fuel-Burning Appliances and the ANSI NFPA 70 National Electrical Code are to be followed in the absence of local code requirements.

This insert must be installed with a continuous chimney liner of 6" diameter extending from the insert to the top of the chimney. The chimney liner must conform to the Class 3 requirements of CAN/ULC-S635, Standard for Lining Systems for Existing Masonry or Factory-built Chimneys and Vents, or CAN/ULC-S640, Standard for Lining Systems for New Masonry Chimneys.

**The insert is not approved for use with a so-called “positive flue connection” to the clay tile of a masonry chimney.**

## 9 CLEARANCES TO COMBUSTIBLE MATERIAL

The clearances shown in this section have been determined by test according to procedures set out in safety standards ULC S628 (Canada), UL1482 (U.S.A.) and UL737 (U.S.A.). When the insert is installed so that its surfaces are at or beyond the minimum clearances specified, combustible surfaces will not overheat under normal and even abnormal operating conditions.

**NO PART OF THE INSERT MAY BE LOCATED CLOSER TO COMBUSTIBLES THAN THE MINIMUM CLEARANCE FIGURES GIVEN.**

### 9.1 CERTIFICATION LABEL

Since the information given on the certification label attached to the appliance always overrides the information published in any other media, it is important to refer to it to have a safe and compliant installation. The model and the serial number can also be found on the label.

The certification label is usually located on the side of the insert, towards the front. The faceplate may need to be removed to see it. Therefore, it is recommended to note the insert serial number on page 4 of this manual. It will be needed to identify the version of the appliance in the event replacement parts or technical assistance is required. It is also recommended to [register the warranty online](#).

### 9.2 MASONRY FIREPLACE THROAT DAMPER

If the fireplace's draft control system is to remain in the masonry fireplace, it must be locked open for access of the chimney liner or removed entirely. If you remove draft control system from the masonry hearth, you will need to install the metal plate (27009), supplied with the owner's manual kit, indicating that the masonry hearth has been modified. It must be secured inside the masonry hearth, in a visible place and easy to locate.

THIS FIREPLACE MAY HAVE BEEN ALTERED TO ACCOMMODATE A FIREPLACE INSERT AND SHOULD BE INSPECTED BY A QUALIFIED PERSON PRIOR TO RE-USE AS A CONVENTIONAL FIREPLACE.

☺ CE FOYER A PEUT-ÊTRE ÉTÉ MODIFIÉ AFIN DE RECEVOIR UN APPAREIL ENCASTRABLE, IL DOIT DONC ÊTRE VÉRIFIÉ PAR UNE PERSONNE QUALIFIÉE AFIN DE DÉTERMINER SA CONFORMITÉ AU CODE LOCAL AVANT DE LE RÉUTILISER. ☺

27009

### 9.3 INSTALLATION OF A COMBUSTIBLE MANTEL SHELF

It is possible to install a combustible shelf with a maximum depth of 12" at a height of at least 27" above the insert. At a height of more than 27", the shelf must still have a maximum depth of 12".

Table 2: Mantel Shelf Clearances

MAXIMUM MANTEL SHELF DIMENSION (X)	MANTEL SHELF CLEARANCES (I)
12" (305 mm) max.	27" (686 mm) min.

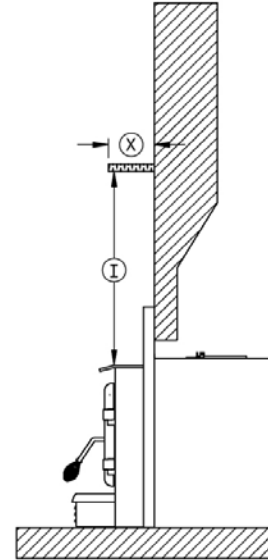

### 9.4 FLOOR PROTECTION

It is necessary to have a floor protection made of non-combustible materials that meets the measurements specified in the «Table 3: Floor Protection» below.

Table 3: Floor Protection

	FLOOR PROTECTION	
	Canada	USA
<b>B</b>	18" (457 mm) <sup>1</sup>	16" (406 mm) <sup>1</sup>
<b>M</b>	8" (203 mm)	N/A
<b>N</b>	N/A	8" (203 mm)

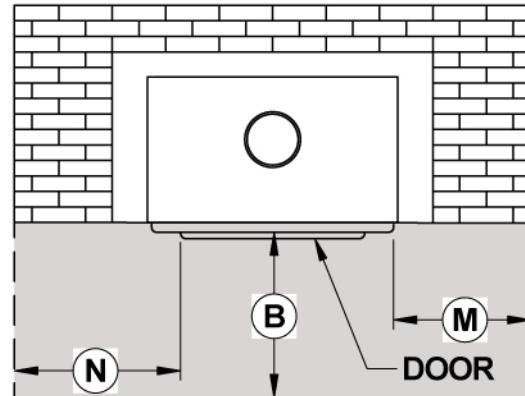

<sup>1</sup>From door opening. The depth of the hearth extension in front of the insert is included in the calculation of the floor protector's dimensions. The masonry hearth should be at least 5" (127 mm) higher than the combustible floor in front of it and a floor protection must extend at least 16" (406 mm USA) and at least 18" (457 mm Canada) without an R value. If the hearth elevation is lower than 5" (127 mm), the non-combustible floor protector in front of the insert should have an R value equal or greater than 1.00 and shall extend 23" (584 mm) in front of the unit.



To determine the need to add floor protection (D) beyond the hearth extension, do the following calculation using the data in «Table 4 : Data for Floor Protection Calculation» of this section:  
 $D = B - (A - C)$ .

The standard configuration of the insert leaves no projection of the convection air jacket in front of the fireplace opening. Therefore, the minimum projection is 0". Although it is possible to position the insert to obtain a projection of 2" (51 mm) or 4" (102 mm) of the convection air jacket in front of the fireplace opening with the use of the projection kit. The choice of the configuration will depend on the previous installation instructions and compliance with building code.

**Table 4 : Data for Floor Protection Calculation**

	<b>A</b>	<b>B</b>	<b>C</b>	<b>D</b>	<b>E</b>	<b>Air Jacket</b>
<b>Maximum Extended</b>	Dimensions of the hearth extension	See section 9.4.1 and 9.4.2	2" / 4" (51 / 102 mm)	$D=B-(A-C)$	10" / 12" (254 / 305 mm)	Back from fireplace facing 2" or 4"
<b>Minimum Extended</b>	Dimensions of the hearth extension	See section 9.4.1 and 9.4.2	0" (0 mm)	$D=B-(A-C)$	14" (356 mm)	Flush with fireplace facing

If the value (D) is negative or zero, additional floor protection in front of the unit is not needed because the masonry fireplace hearth extension is large enough. If the value (D) is positive, an additional floor protection in front of the hearth extension at least equivalent to the result (D) must be added.

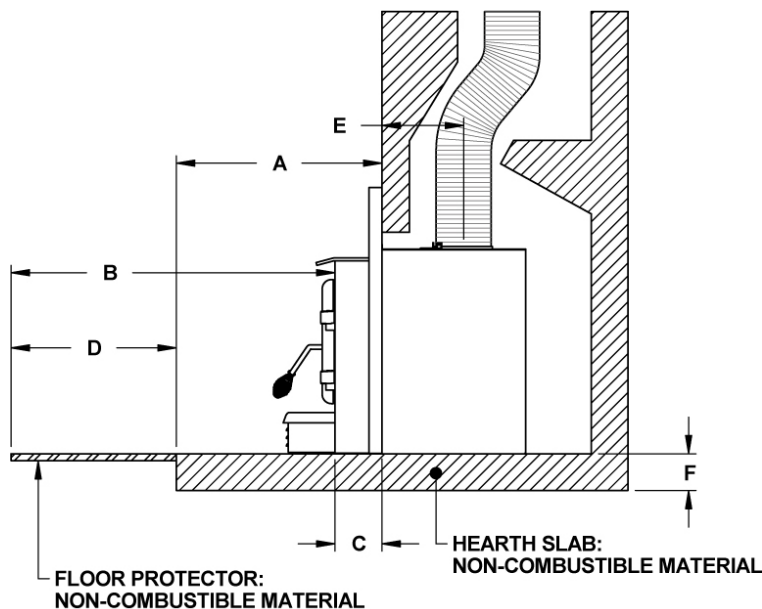

**9.4.1 INSTALLATION RAISED OF 5" AND LESS**

If non-combustible material floor protection needs to be added in front of and level with the hearth extension of the masonry fireplace (F = 5" or less), an R-value equal to or greater than 1.00 is required and should extend at least 23" (584 mm) in front of the unit (B).

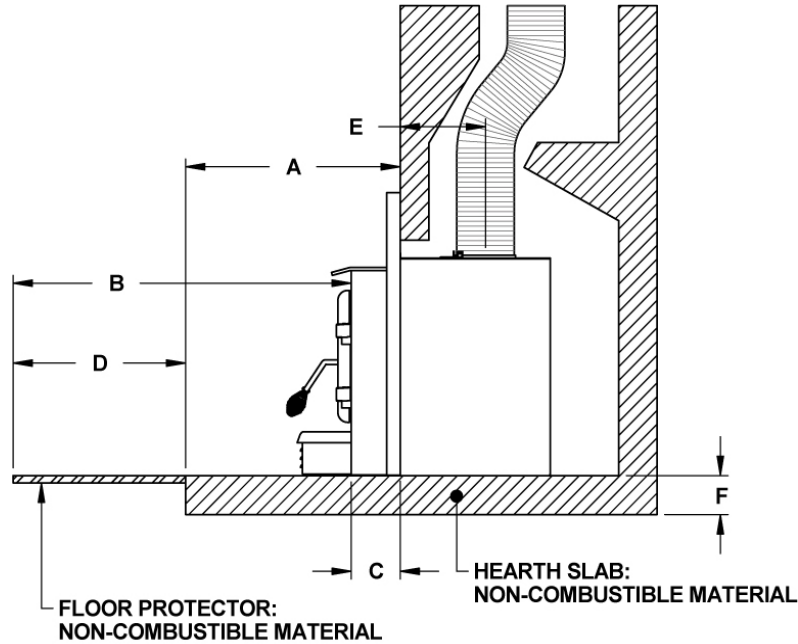

**9.4.2 INSTALLATION RAISED OF MORE THAN 5"**

If the extension of the masonry hearth is raised at least 5" (127 mm) from the floor protection, a non-combustible material, without an R-value, must extend at least 16" (406 mm in USA) or 18" (457 mm in Canada) in front of the unit.

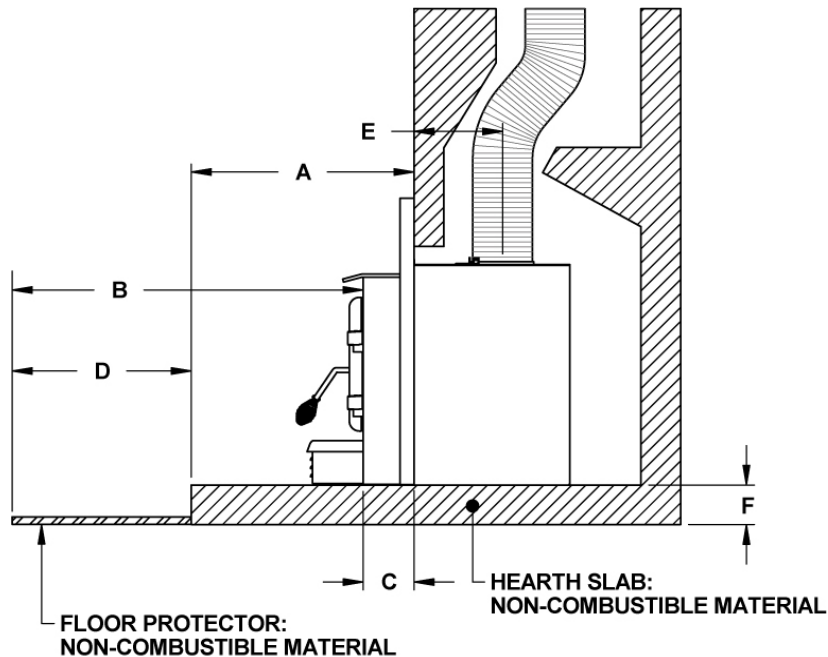

**9.4.3 R VALUE**

There are two ways to calculate the R-value of the floor protection. First, by adding the R-values of materials used, or by the conversion if the K factor and thickness of the floor protection are given.

To calculate the total R value from R values of the materials used, simply add the R-values of materials. If the result is equal to or greater than the R-value requirements, the combination is acceptable. R-values of some selected materials are shown below:

**Table 5: Thermal Characteristics of Common Floor Protection Materials\***

<b>MATERIAL</b>	<b>CONDUCTIVITY (k) PER INCH</b>	<b>RESISTANCE (R) PER INCH THICKNESS</b>
Micore® 160	0.39	2.54
Micore® 300	0.49	2.06
Durock®	1.92	0.52
Hardibacker®	1.95	0.51
Hardibacker® 500	2.3	0.44
Wonderboard®	3.23	0.31
Cement mortar	5.00	0.2
Common brick	5.00	0.2
Face brick	9.00	0.11
Marble	14.3 – 20.00	0.07 – 0.05
Ceramic tile	12.5	0.008
Concrete	1.050	0.950
Mineral wool insulation	0.320	3.120
Limestone	6.5	0.153
Ceramic board (Fibremax)	0.450	2.2
Horizontal still air** (1/8")	0.135	0,920**

\* Information as reported by manufacturers and other resources

\*\*Horizontal still air can't be «stack» to accumulate R-values; each layer must be separated with another non-combustible material.

**Example:**

Required floor protection R of 1.00. Proposed materials: four inches of brick and one inch of Durock® board.

Four inches of brick ( $R = 4 \times 0,2 = 0,8$ ) plus 1 inch of Durock® ( $R = 1 \times 0.52 = 0.52$ ).

$$0.8 + 0.52 = 1.32.$$

This R value is larger than the required 1.00 and is therefore acceptable.

In the case of a known K and thickness of alternative materials to be used in combination, convert all K values to R by dividing the thickness of each material by its K value. Add R values of the proposed materials as shown in the previous example.

**Example:**

K value = 0.75

Thickness = 1

R value = Thickness/K = 1/0.75 = 1.33

**9.5 MINIMUM MASONRY OPENING, CLEARANCES TO COMBUSTIBLES**

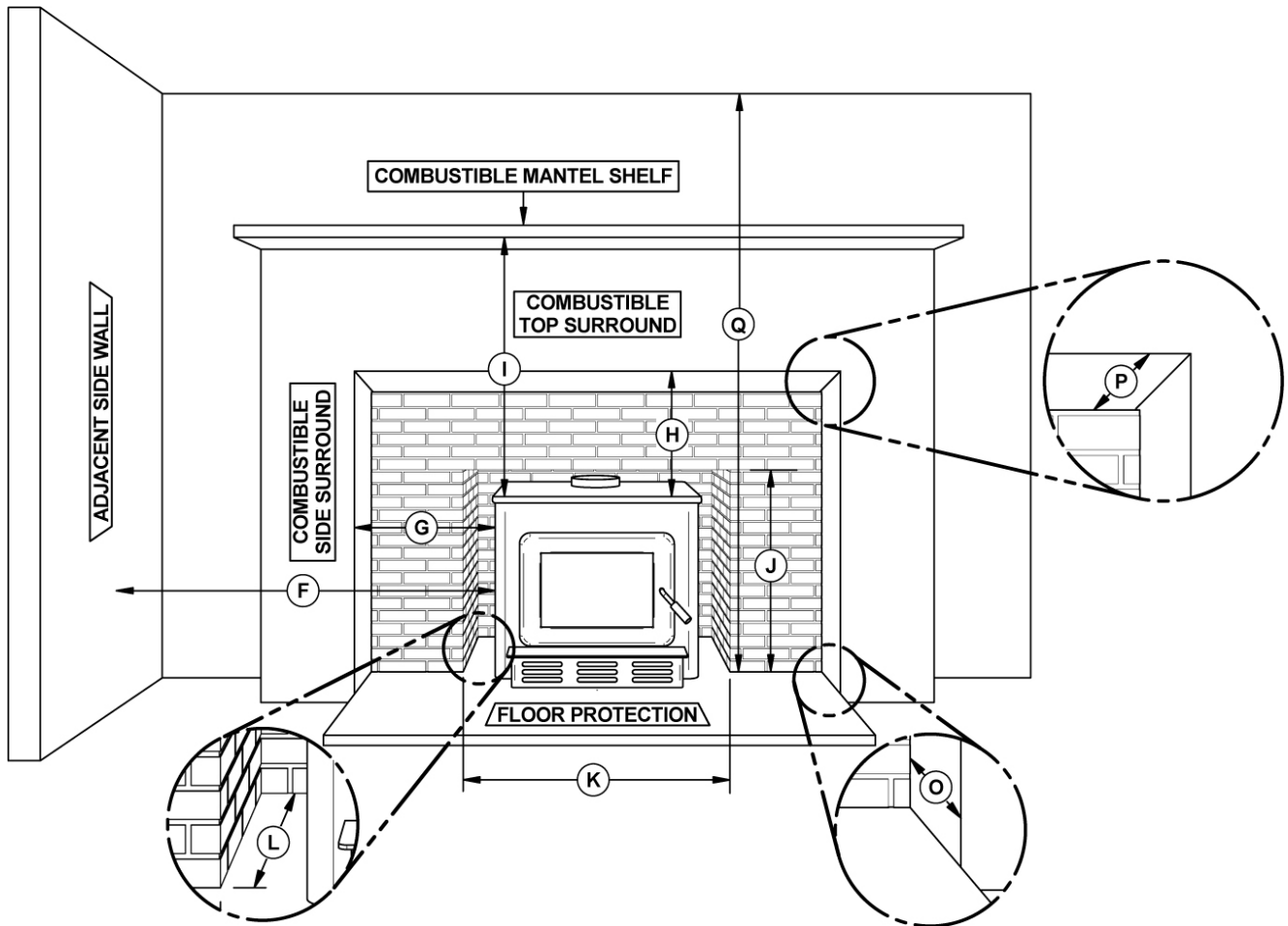

	CLEARANCES
F	16" (406 mm)
G	9" (229 mm)
H	27" (686 mm)
I	27" (686 mm)
Q	84" (213 cm)

	MINIMUM MASONRY OPENING
J	23 5/16 " (592 mm)
K	28 7/8 " (733 mm)*
L	19 5/8 " (498 mm)**

	MAXIMUM THICKNESS
O	5" (127 mm)
P	12" (305 mm)

\* Where a fresh air intake is needed, we suggest you add a minimum of 4" to the width of the minimum masonry opening.

\*\* If projection kit is used L = 17 5/8" or 15 5/8". If installed without projection kit L = 19 5/8".

## 10 THE VENTING SYSTEM

### 10.1 GENERAL

The venting system, made up of the chimney and the liner inside the chimney, acts as the engine that drives your wood heating system. Even the best insert will not function safely and efficiently as intended if it is not connected to a suitable chimney and liner system.

The heat in the flue gases that pass from the insert into the chimney is not waste heat. This heat is what the chimney uses to make the draft that draws in combustion air, keeps smoke inside the insert and safely vents exhaust to outside. The heat in the flue gas can be seen as the fuel the chimney uses to create draft.

### 10.2 BLOCK-OFF PLATE

To reduce the possibility of a cold air back draft from the masonry chimney into the room, the installation of a sheet metal block-off plate (**A**) is recommended. When fabricating the block-off plate, cut the pipe hole slightly larger than the liner diameter and pass the liner through the hole. Install the block-off plate and secure it with masonry nails. Seal the joints between the plate and the chimney with high temperature silicone and use stove cement to seal between the pipe and the plate.

In Canada, the CSA B365 Standard permits «Roxul» type wool to be stuffed around the liner as it passes through the throat area as an alternative to a sheet metal block-off plate. However, this method is less efficient than using a plate.

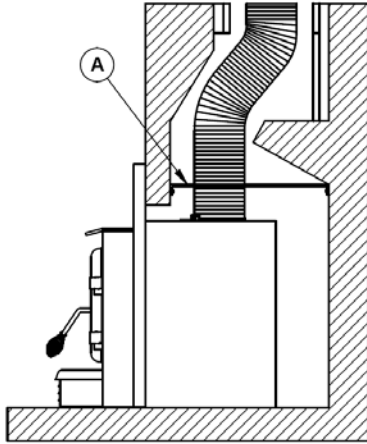

### 10.3 SUITABLE CHIMNEYS

Your wood insert will provide optimum efficiency and performance when connected to a 6-inch diameter chimney liner. The connection to a chimney having a diameter of at least 5 inches (Canada only) is permitted, if it allows the proper venting of combustion gases and that such application is verified and authorized by a qualified installer. Otherwise, the diameter of the flue should be 6 inches. The reduction of liner diameter to less than 6" should only be done if the total height of the masonry chimney is greater than 20 feet.

### 10.4 LINER INSTALLATION

The use of a chimney liner (rigid or flexible) is recommended to ensure the best performance. To ensure an optimal draft, it is also strongly recommend adding a minimum of 12" rigid liner between the top of the masonry chimney and the rain cap. In all cases, liners should be installed in accordance with the liner manufacturer's instructions, including instructions for extension above the masonry.

Use chimney liners listed UL 1777, ULC S635 or CAN/ ULC S640.

In order to connect the insert to the liner, refer to section «10.5 Chimney Liner Installation».

**ATTENTION INSTALLER:** When positioning the unit in a fireplace opening prior to the flue installation, install the insert into the opening until the top lip of air jacket is flush with fireplace facing.

If lag bolts or anchors are to be used to secure the insert, the hole locations should be marked with the unit in place. Remove the insert and locate the anchors.

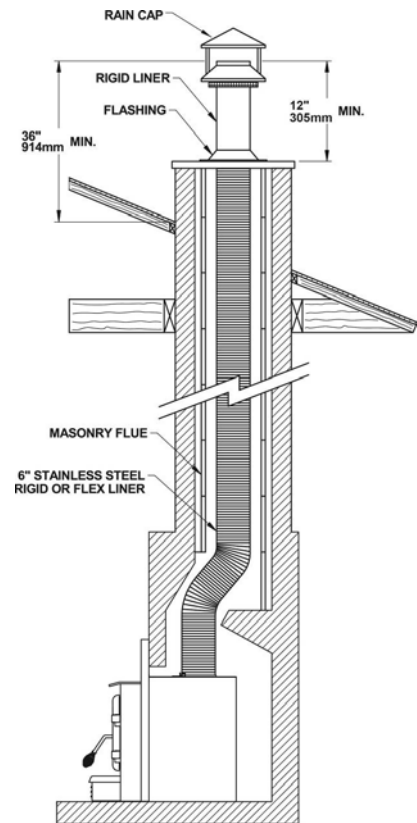

## 10.5 LINER CONNECTION

Two options are possible to connect the liner to the insert:

### 10.5.1 LINER STARTER ADAPTOR

Two options are possible:

Install the chimney liner starter adaptor, provided with the chimney liner. Follow the chimney liner starter adaptor manufacturer's instructions.

In order to connect the chimney liner starter adaptor to the flue outlet, install three brackets with the three screws, all provided in the user manual, on top of the insert.

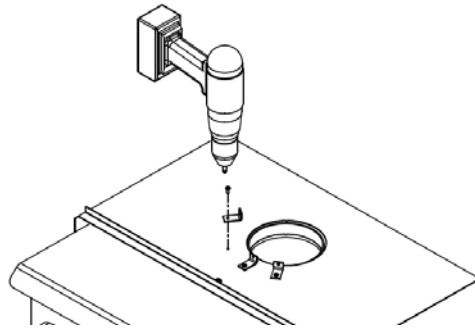

The long end of the brackets must be attached to the insert. Insert the chimney liner into the flue collar of the unit and secure the liner to the brackets with three self-tapping screws (not included).

The dealer may offer a liner fastening system (AC02006), sold separately. Follow the installation instructions provided with the liner fastening system.

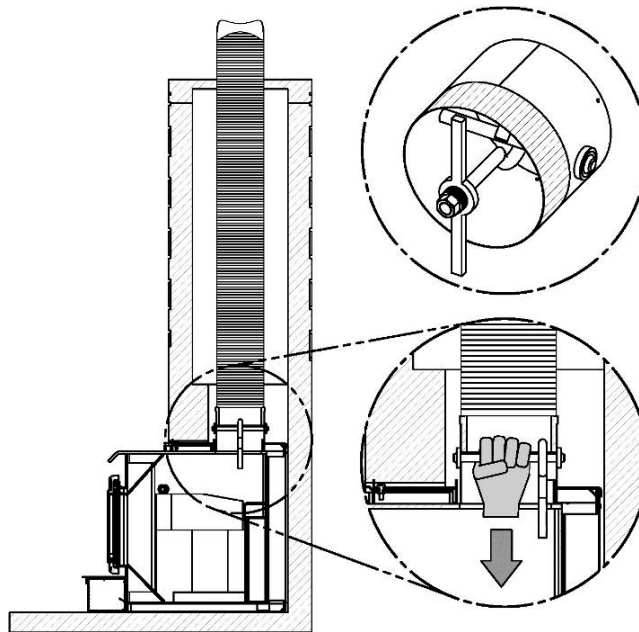

### 10.5.2 LINER OFFSET ADAPTOR

A liner offset adaptor, sold separately, can also be installed. This should only be installed if no other option is possible and if the total height of the fireplace and chimney is at least 20 feet. This kind of adaptor is restricting the free flow of exhaust gases and may result in smoke roll-out from the insert when the door is open for reloading. When installing a liner offset adaptor, secure the three brackets provided in the user manual on top of the insert. The long end of the brackets must be attached to the insert. Then, follow the instructions in the manual provided with the liner offset adaptor kit.

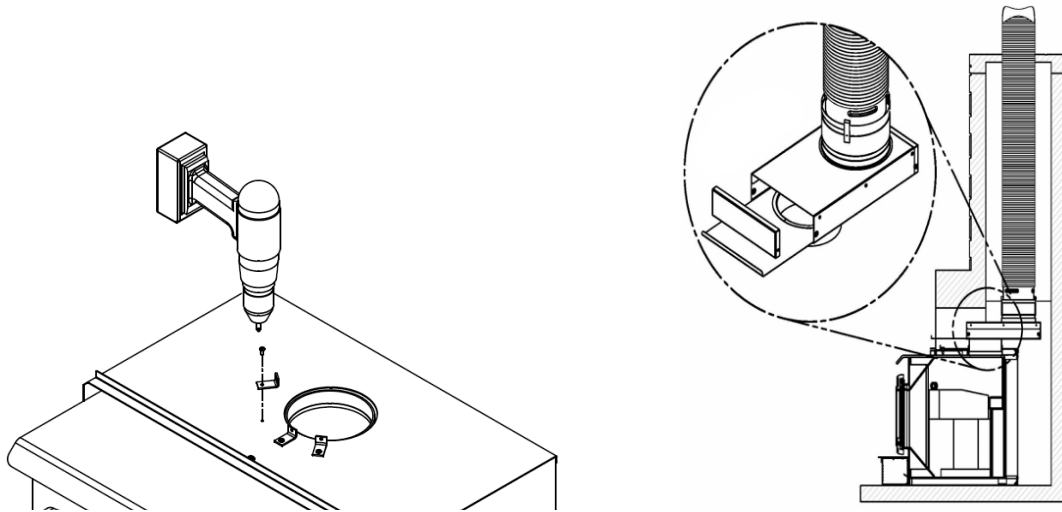

### 10.6 MINIMUM CHIMNEY HEIGHT

The top of the chimney should be tall enough to be above the air turbulence caused when wind blows against the house and its roof. The chimney must extend at least 1 m (3 ft.) above the highest point of contact with the roof, and at least 60 cm (2 ft.) higher than any roof line or obstacle within a horizontal distance of 3 m (10 ft.).

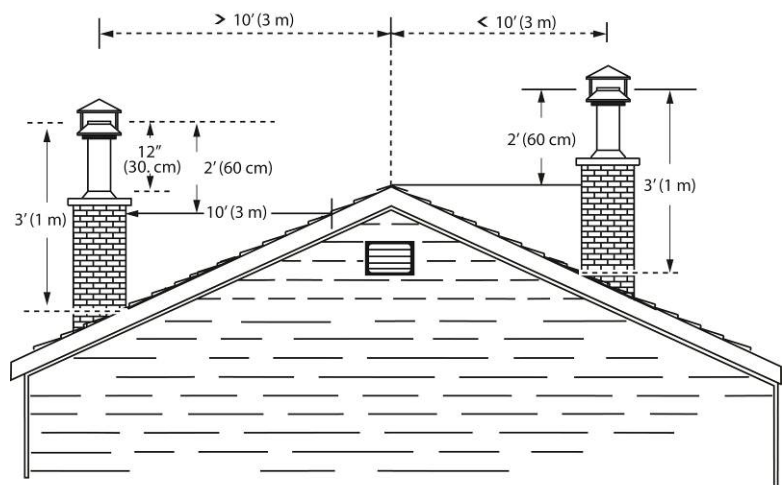



## 10.7 CHIMNEY LOCATION

Because the venting system is the engine that drives the wood heating system, it must have the right characteristics. The signs of bad system design are cold back drafting when there is no fire in the insert, slow kindling of new fires, and smoke roll-out when the door is opened for loading.

When it is cold outside, the warm air in the house is buoyant so it tends to rise. This tendency of warm air to rise creates a slight pressure difference in the house. Called 'stack effect', it produces a slightly negative pressure low in the house (relative to outside) and a slightly positive pressure zone high in the house. If there is no fire burning in a heater connected to a chimney that is shorter than the warm space inside the house, the slight negative pressure low in the house will compete against the desired upward flow in the chimney.

There are two reasons why the chimney in the house at right will cold backdraft when it is cold outside and there is no fire burning in the insert. First, the chimney runs up the outside of the house, so the air in it is colder and denser than the warm air in the house. And second, the chimney is shorter than the heated space of the house, meaning the negative pressure low in the house will pull outside air down the chimney, through the insert and into the room. Even the finest insert will not work well when connected to this chimney.

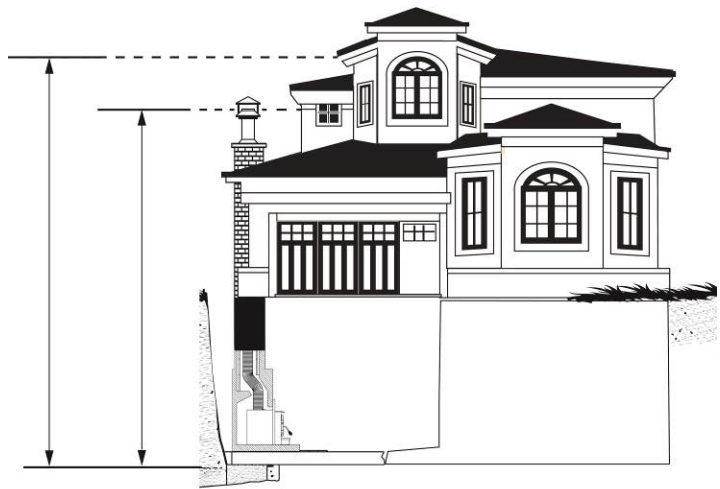

## 10.8 SUPPLY OF COMBUSTION AIR

In Canada, wood inserts are not required to have a combustion air supply from outside. Research has shown that outside air supply do not compensate for the depressurization of the house and may not be sufficient to provide a supply of combustion air in windy weather. However, to reduce the risks against smoke spillage due to house depressurization, a carbon monoxide (CO) detector is required in the room where the insert is installed. The CO detector will provide warning if for any reason the wood insert fails to function correctly.

The safest and most reliable supply of combustion air for a wood insert is from the room in which it is installed. Room air is already preheated so it will not chill the fire, and its availability is not affected by wind pressures on the house. Contrary to commonly expressed concerns, almost all tightly sealed new houses have enough natural leakage to provide a small amount of air needed by the insert. The only case in which the wood insert may not have adequate access to combustion air is if the operation of a powerful exhaust device (such as a kitchen range exhaust) causes the pressure in the house to become negative relative to outdoors.

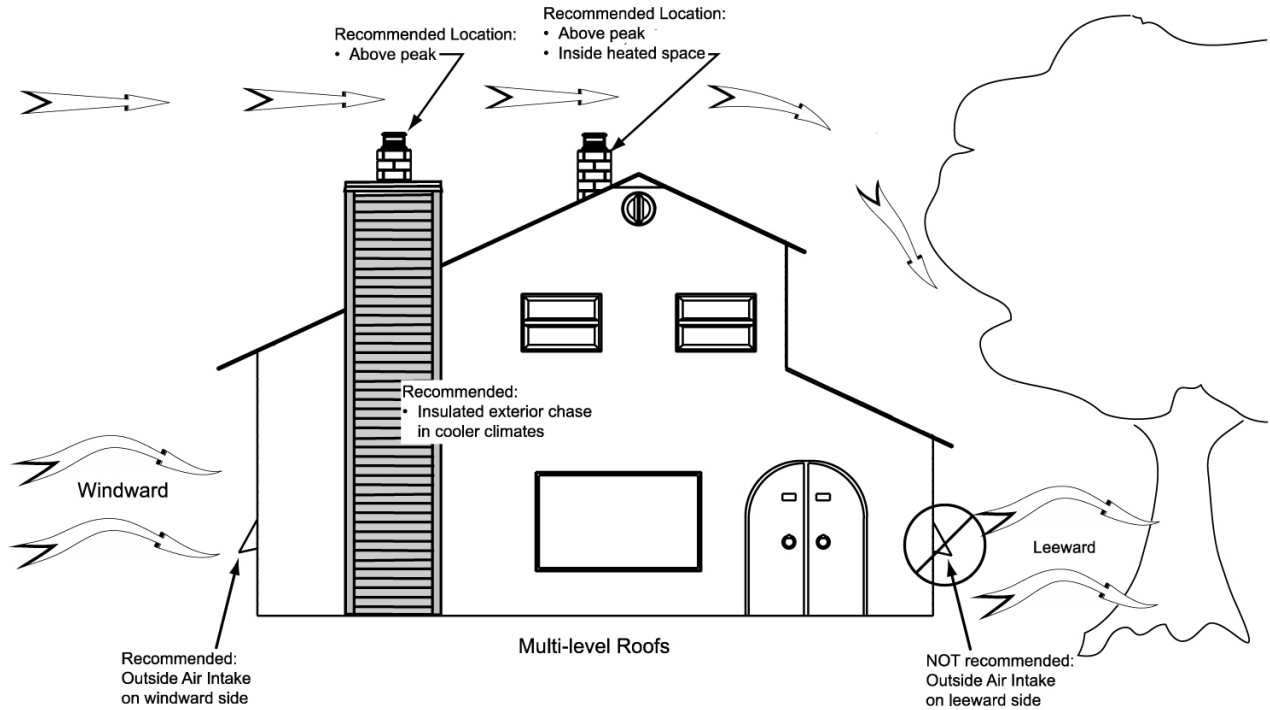

If an air intake is installed through the wall of the house, its pressure can vary during windy weather. If there are changes in wood insert performance in windy weather, and in particular if smoke puffs from the insert, the air duct should be disconnected from the insert to determine if it is the cause of the problem. In some windy conditions, negative pressure at the duct weather hood outside the house wall may draw hot exhaust gases from the insert backwards through the duct to outdoors. Check the outdoor air duct for soot deposits when the full system is cleaned and inspected at least once each year.

## APPENDIX 1: INSTALLING THE FACEPLATE

**NOTE:** If the depth and or the opening of the masonry hearth require the use of the optional projection kit and/or an optional faceplate backing plate kit, follow the instructions included with these options before beginning the installation of the cast iron faceplate

1. Remove the steel faceplate already installed on the insert.
2. Put together the steel face plate with the three parts of the cast iron faceplate.

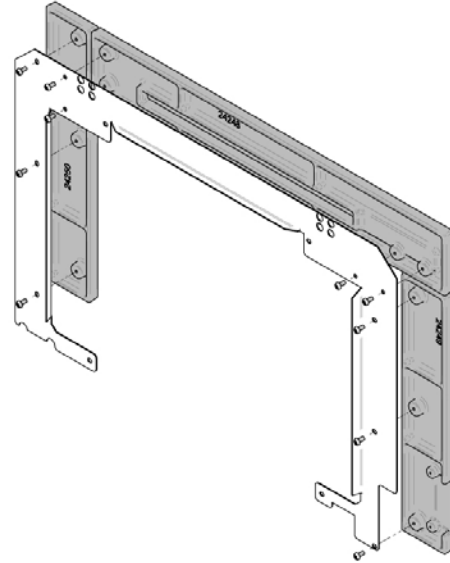
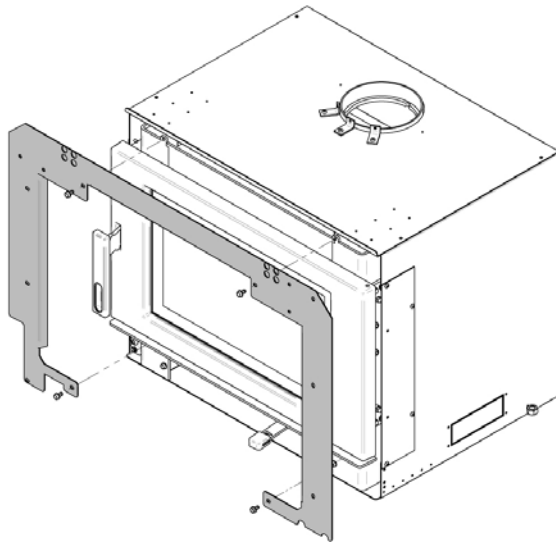

3. Pull gently on the blower switch assembly. It is very important not to disconnect the wires.
4. Approach the faceplate and screw the blower switch assembly on the left hand side.

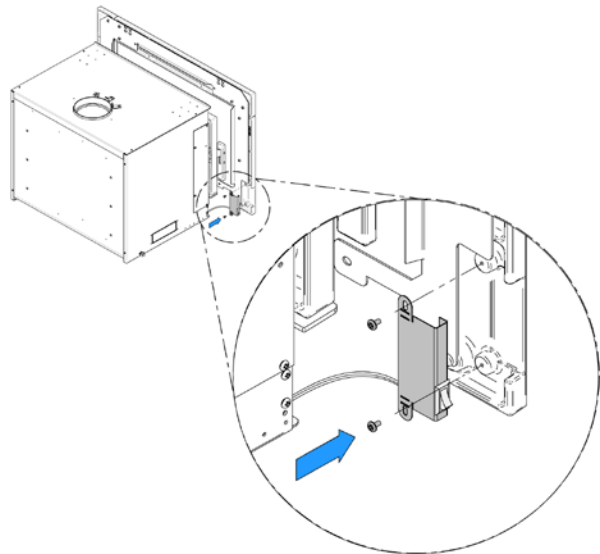
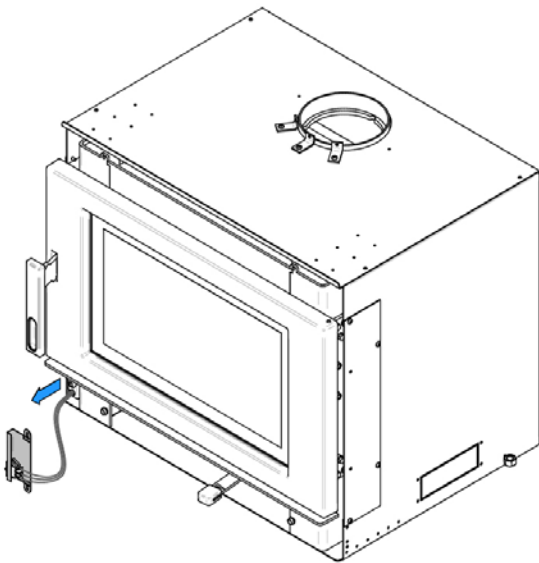

5. Install the faceplate on the insert, being careful not to pinch the blower switch wires.
6. Remove the air control wooden handle.

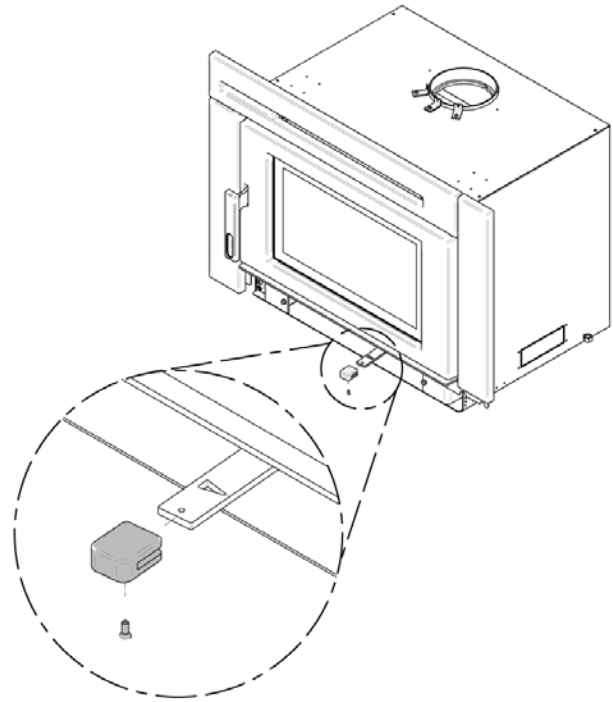
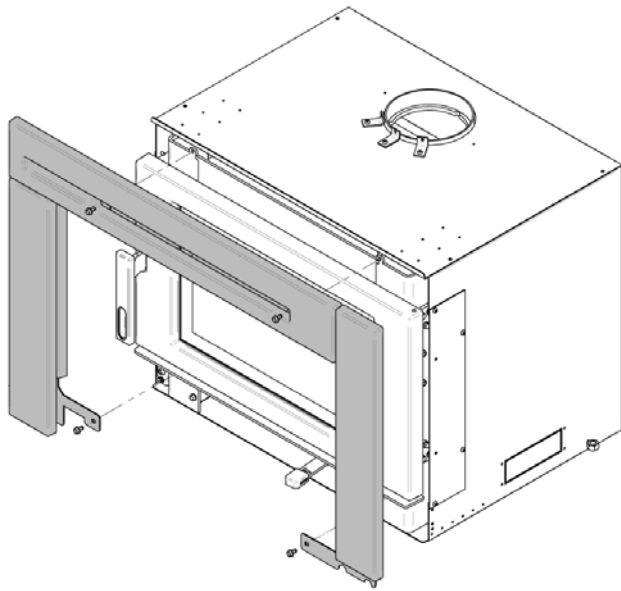

7. Slightly unscrew the two screws at the bottom of the insert. Hook the bottom faceplate and screw it back in place. Reinstall the wood handle.

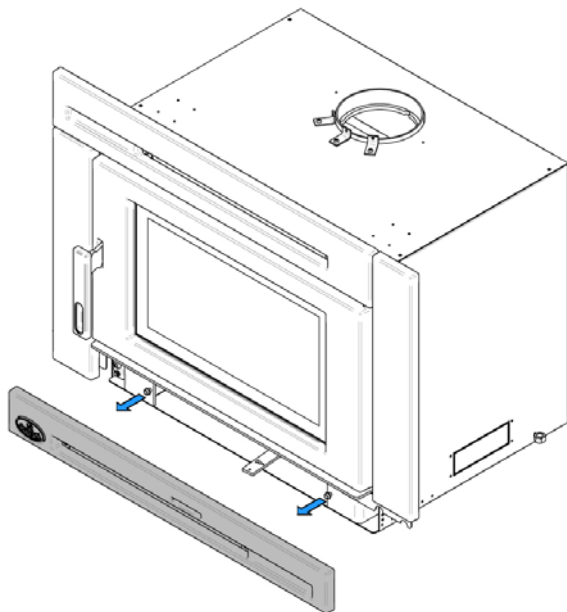

## APPENDIX 2: INSTALLING THE OPTIONAL FIRE SCREEN

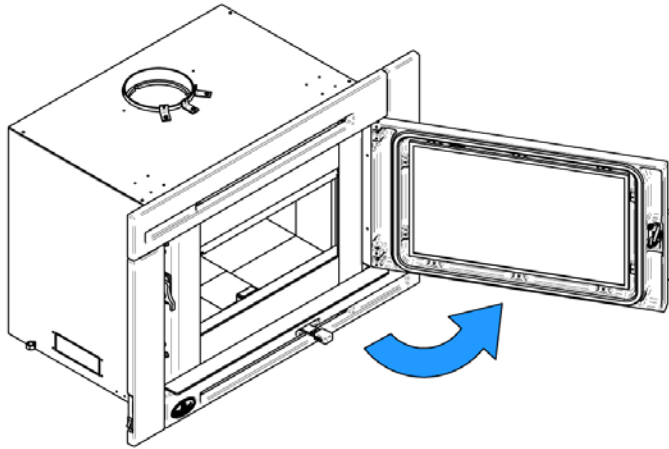

Open the door.

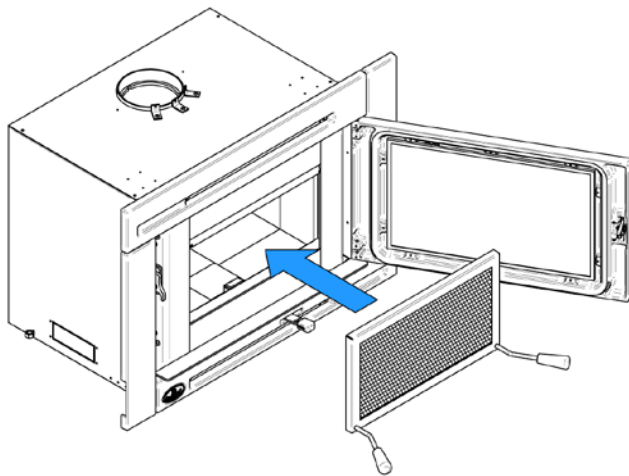

Hold the fire screen by the two handles and bring it close to the door opening.

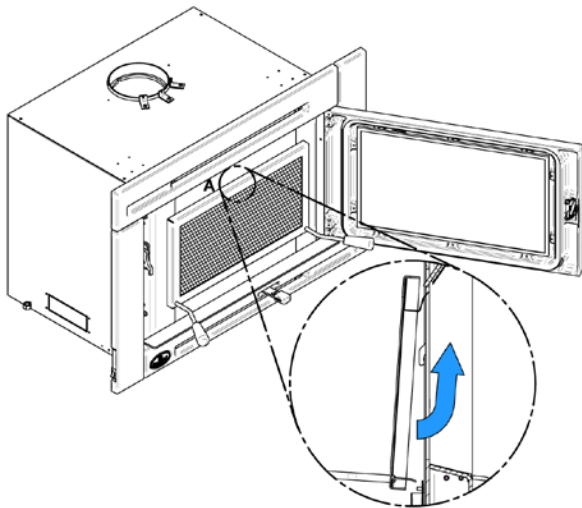

Lean the upper part of the fire screen against the top door opening making sure to insert the top fire screen brackets behind the primary air deflector.

Lift the fire screen upwards and push the bottom part towards the insert then let the fire screen rest on the bottom of the door opening.

**Warning:** *Never leave the insert unattended while in use with the fire screen.*

### APPENDIX 3: INSTALLING THE OPTIONAL FRESH AIR INTAKE KIT

**Note:** Only remove the knock-out that will be connected to the fresh air inlet.

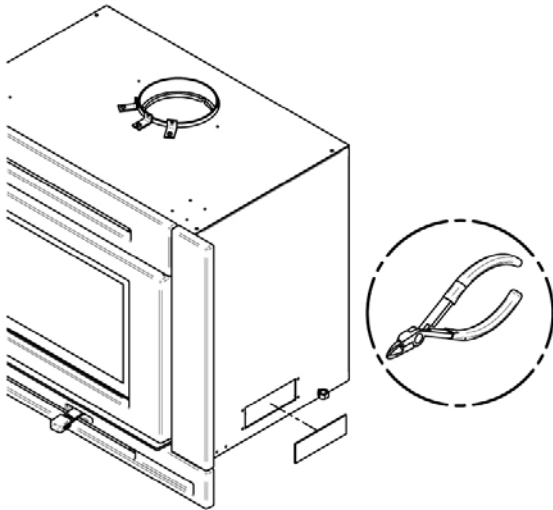

Using pliers, remove the rectangular knock-out plate (A) located on the left or right side of the convection air jacket. Choose the side that is best for your installation.

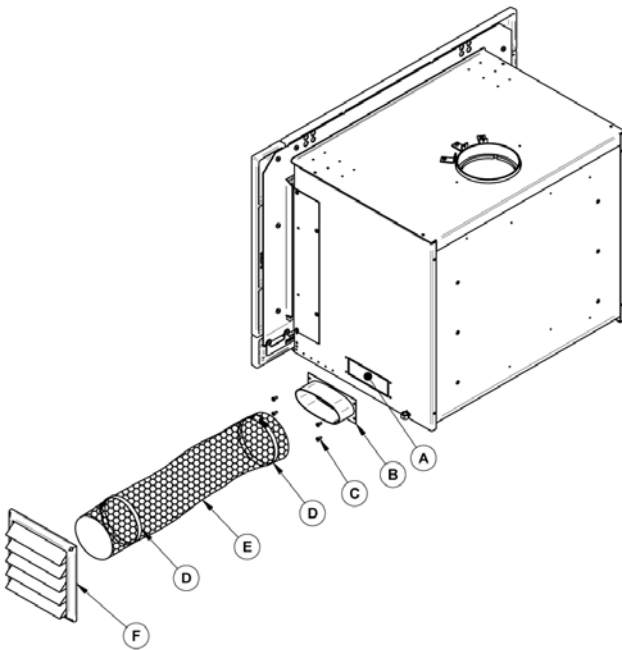

Then, install the fresh air kit adapter (B) using 4 screws (C). Secure the flexible pipe<sup>1</sup> (E) to the adapter (B) using one of the adjustable pipe clamps (D). Secure the other end of the pipe to the outside wall termination (F) using the second adjustable pipe clamp (D). The outside wall termination (F) must be installed outside of the building.

<sup>1</sup> The pipe must be HVAC type, insulated, and must comply with ULC S110 and/or UL 181, Class 0 or Class 1.

## APPENDIX 4: BLOWER REPLACEMENT

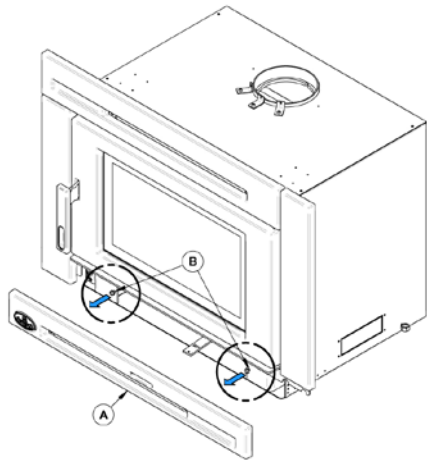

1. Slightly loosen screws (B).
2. Lift the faceplate (A) by ½" then pull it towards you to remove.

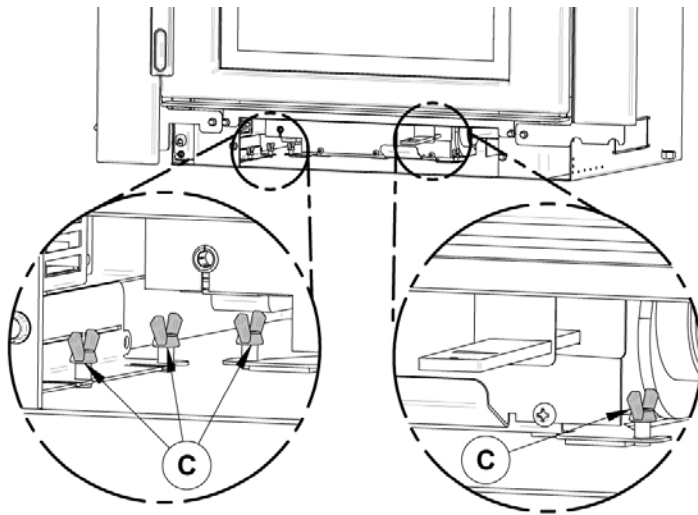

3. Slightly loosen the 4 wing nut (C) then pull the blower assembly (D) towards you to remove it from the convection air jacket. Make sure to disconnect the wiring as it is accessible.

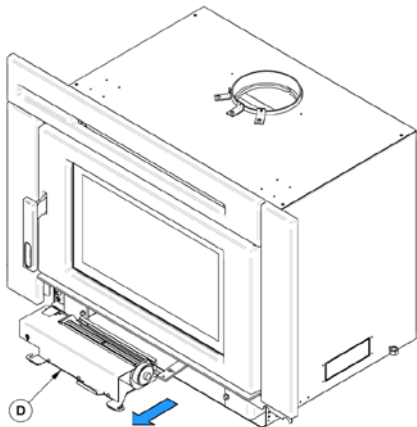

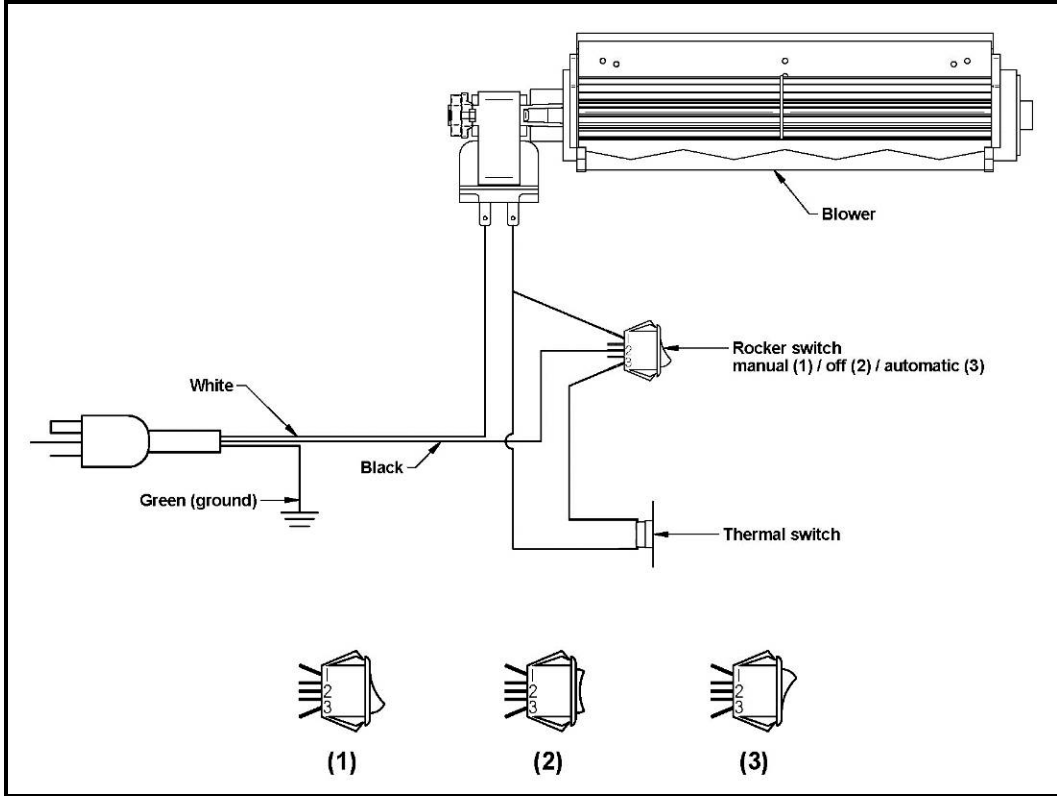



## APPENDIX 5: INSTALLATION OF SECONDARY AIR TUBES AND BAFFLE

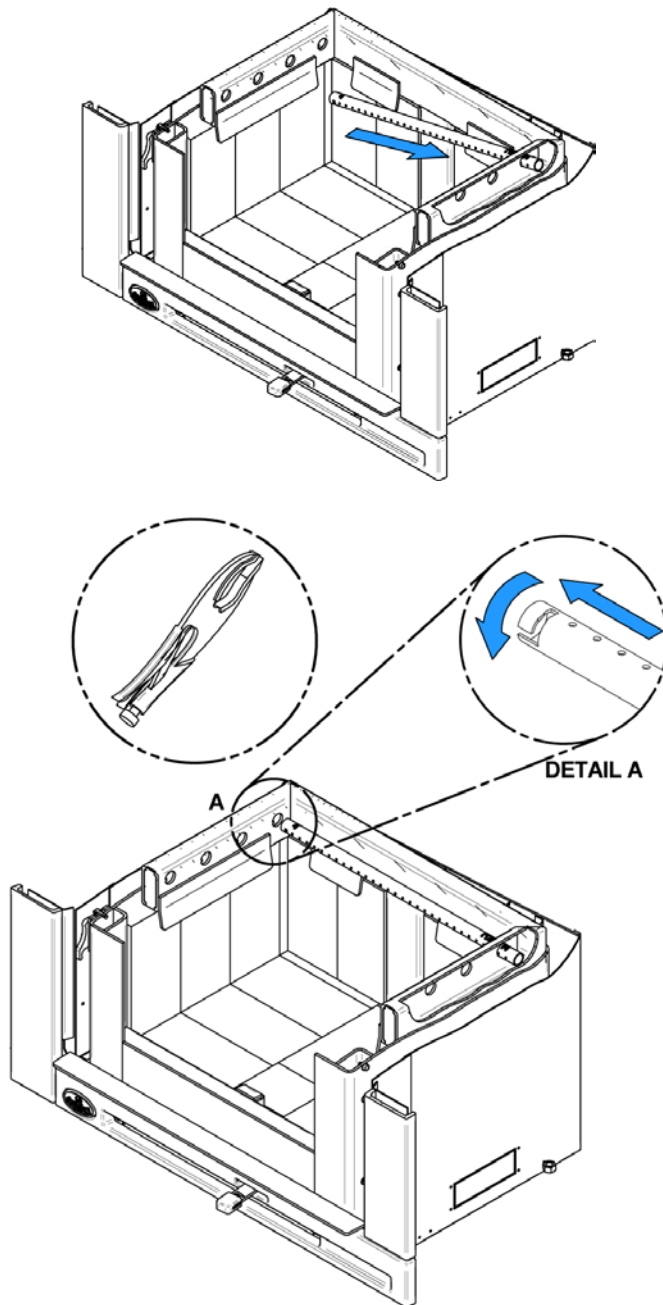

1. Starting with the rear tube, lean and insert the right end of the secondary air tube into the rear right channel hole. Then lift and insert the left end of the tube into the rear left channel.
  
2. Align the notch in the left end of the tube with the key of the left air channel hole. Using a « Wise grip » hold the tube and lock it in place by turning the tube as shown in **DETAIL A**. Make sure the notch reaches the end of the key way.
  
3. Repeat **steps 1** and **2** for the two tubes in the back then install the baffle before installing the two front tubes.
  
4. To remove the tubes use the above steps in reverse order.

**Note that** secondary air tubes (B) can be replaced without removing the baffle board (A).

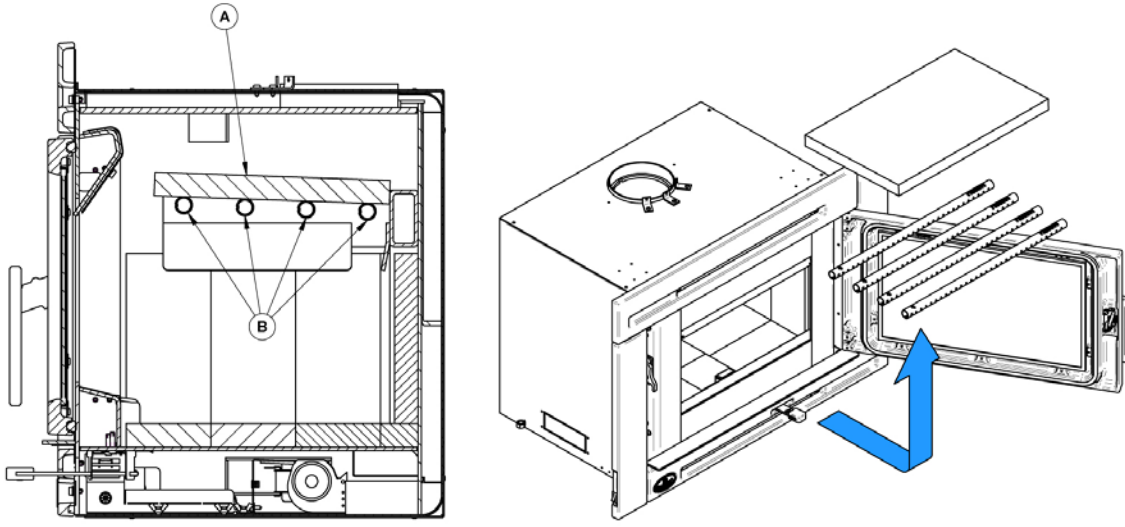

## APPENDIX 6: REMOVAL INSTRUCTIONS

For the purpose of inspecting the insert itself or the fireplace, your insert may need to be removed. To remove your insert follow these instructions:

- Remove the faceplate assembly (A) using the reverse steps of **Appendix 1**.
- If installed, take-off the backing plates (B) and (C) and the projection kit by removing the front screws securing them to the insert.
- Remove the screws that secure the chimney liner to the fixation brackets (E).
- Unscrew the leveling bolts (F) located on each side of the insert.
- Pull-out the insert from the fireplace opening to perform the maintenance work.

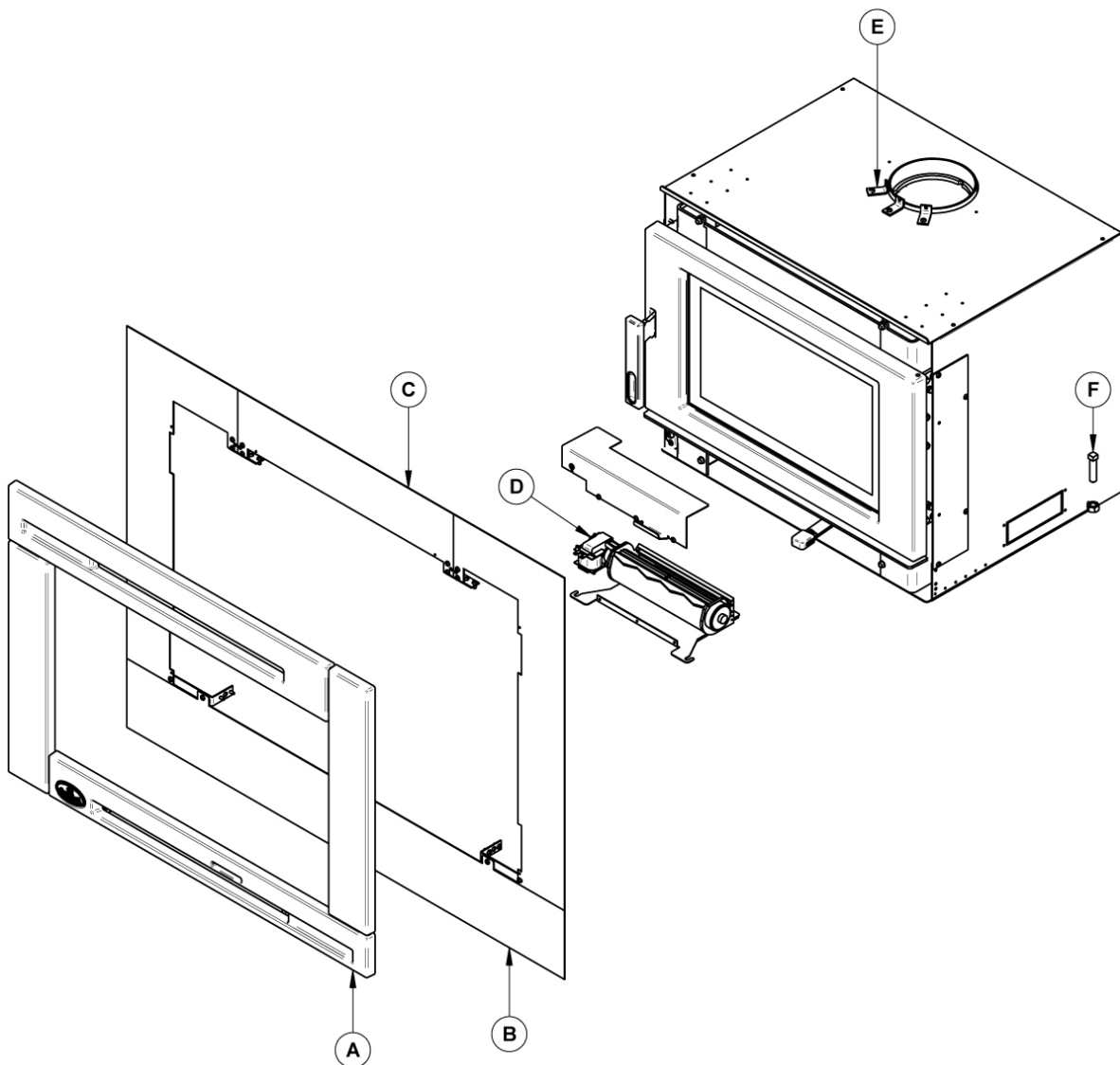

# APPENDIX 7: EXPLODED DIAGRAM AND PARTS LIST

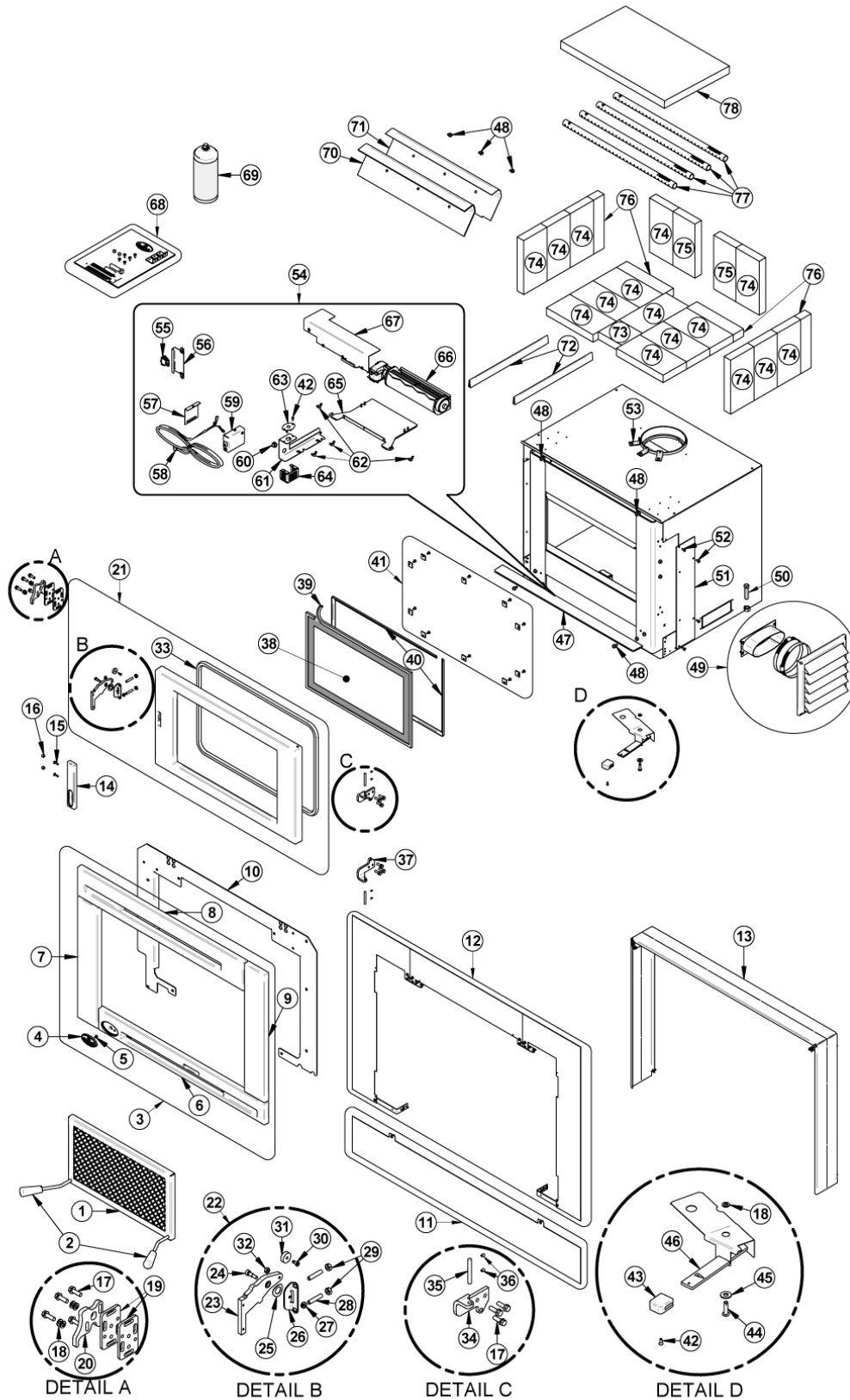

**IMPORTANT:** THIS IS DATED INFORMATION. When requesting service or replacement parts for your insert, please provide the model number and the serial number. We reserve the right to change parts due to technology upgrade or availability. Contact an authorized dealer to obtain any of these parts. Never use substitute materials. Use of non-approved parts can result in poor performance and safety hazards.

#	Item	Description	Qty
1	AC01315	RIGID FIRESCREEN	1
2	30569	ROUND WOODEN HANDLE BLACK	2
3	SE24248	FACEPLATE KIT FOR MATRIX INSERT	1
4	30450	OSBURN DOOR LOGO	1
5	30124	SCREW #8 - 32 X 5/16" TRUSS QUADREX ZINC	1
6	PL24247	BOTTOM CAST IRON FACEPLATE PAINTED BLACK	1
7	PL24249	LEFT CAST IRON FACEPLATE PAINTED BLACK	1
8	PL24248	TOP CAST IRON FACEPLATE PAINTED BLACK	1
9	PL24250	RIGHT CAST IRON FACEPLATE PAINTED BLACK	1
10	PL65087	FACEPLATE SUPPORT	1
11	AC01321	BOTTOM FACEPLATE BACKING PLATE 44" X 6"	1
11	AC01333	BOTTOM BACKING PLATE FOR FACEPLATE 50" X 6"	1
12	AC01322	29" X 44" FACEPLATE BACKING PLATE KIT	1
12	AC01332	29" X 50" FACEPLATE BACKING PLATE KIT	1
13	AC01323	2" OR 4" PROJECTION KIT FOR INSERT	1
14	30765	WOODEN DOOR HANDLE	1
15	30123	SCREW #8 - 32 X 5/8" PAN QUADREX ZINC	2
16	30766	WOODEN CAP HANDLE	2
17	30094	HEX SCREW WASHER HEAD 1/4-20 X 3/4" F ZINC TYPE	10
18	30187	STAINLESS WASHER ID 17/64" X OD 1/2"	3
19	PL65075	LATCH SHIM	2
20	PL65076	DOOR LOCK	1
21	SE24245-01	CAST IRON DOOR WITH GASKET AND HANDLE	1
22	SE65073	HANDLE REPLACEMENT KIT	1
23	PL65073	DOOR HANDLE	1
24	30754	HEX SOCKET SHOULDER HEX SCREW #10-24 X 3/8"	1
25	30801	BLACK OXIDE SPRING WASHER	1
26	PL65082	HANDLE SUPPORT	1
27	30238	TWO-WAY LOCKNUT HEX #10-24 ZINC	1
28	30128	SOCKET SET SCREW 1/4"-20 X 1 1/4"	2
29	30100	BLACK HEX NUT 1/4 - 20	2
30	31012	HEX SOCKET SHOULDER HEX SCREW #8-32 3/16" X 1/4"	1
31	31011	BALL BEARING	1
32	30007	HEX LOCK NUT #8-32	1
33	AC06500	SILICONE AND 5/8" X 8' BLACK DOOR GASKET KIT	1

#	Item	Description	Qty
34	PL65614	DOOR HINGE	1
35	30755	DOWEL PIN 1/4" X 2"	2
36	30117	SOCKET SET SCREW #10-32 X 1/4"	4
37	PL65615	HINGE	1
38	SE23051	GLASS WITH GASKET - 20 1/4"W X 12 1/2"H	1
39	AC06400	3/4" (FLAT) X 6' BLACK SELF-ADHESIVE GLASS GASKET	1
40	PL65646	GLASS FRAME	2
41	SE63024	GLASS RETAINER WITH SCREWS KIT (10 UNITS)	1
42	30021	SELF TAPPING SCREW 8-32 "F" TYPE X 7/16" FLAT HEAD PHILLIPS BLACK	2
43	30764	WOODEN AIR CONTROL HANDLE	1
44	30506	SCREW PAN TORX TYPE F 1/4-20 X 1" BLACK	1
45	30206	ZINC WASHER 5/16"ID X 3/4"OD	1
46	SE65842	AIR CONTROL DAMPER ASSEMBLY	1
47	SE65754	ASH LIP	1
48	30060	THREAD-CUTTING SCREW 1/4-20 X 1/2" F HEX STEEL SLOT WASHER C102 ZINC	5
49	AC01298	5"Ø FRESH AIR INTAKE KIT OVAL	1
50	30337	SQUARE HEAD SET SCREW 1/2-13 X 1-3/4"	2
51	PL65731	LATCH AND HINGES ACCESS PANEL	1
52	30131	BLACK METAL SCREW #10 X 1/2" TYPE "A" PAN QUADREX	4
53	PL34052	LINER FIXATION BRACKET	3
54	SE65746	FAN ASSEMBLY	1
55	44092	3 POSITION ROCKER SWITCH	1
56	PL65752	SWITCH BRACKET	1
57	PL65629	JUNCTION BOX COVER	1
58	60013	POWER CORD 96" X 18-3 type SJT	1
59	PL65627	JUNCTION BOX	1
60	30413	SNAP BUSHING	1
61	PL65626	FAN WIRE GUIDE	1
62	30484	WING NUT 1/4-20	4
63	44028	CERAMIC THERMODISC F110-20F	1
64	PL65632	THERMODISC CASING	1
65	PL65746	FAN BOTTOM FIXATION PLATE	1
66	44075	TANGENTIAL BLOWER 1800 115V-60hZ-30W (S) 90 CFM	1
67	PL65748	FAN PROTECTION COVER	1
68	SE45929	INSTRUCTION MANUEL KIT MATRIX INSERT	1
69	AC05959	METALLIC BLACK STOVE PAINT - 342 g (12oz) AEROSOL	1
70	21387	TOP AIR DEFLECTOR INSULATION	1
71	PL65505	TOP AIR DEFLECTOR PROTECTOR	1
72	PL30583	FLOORED BRICK RETAINER	2
73	PL36084	4" X 4 1/2" X 1 1/4" REFRACTORY BRICK	1

#	Item	Description	Qty
74	29020	4 1/2" X 9" X 1 1/4" REFRACTORY BRICK HD	15
75	PL36636	REFRACTORY BRICK 4 1/4" X 9" X 1 1/4"	2
76	PL36056	2" X 9" 1 1/4" REFRACTORY BRICK	4
77	PL65514	SECONDARY AIR TUBE	4
78	21389	C-CAST BAFFLE 20" X 12 1/2" X 1 1/4"	1

## OSBURN LIMITED LIFETIME WARRANTY

The warranty of the manufacturer extends only to the original retail purchaser and is not transferable. This warranty covers brand new products only, which have not been altered, modified nor repaired since shipment from factory. Proof of purchase (dated bill of sale), model name and serial number must be supplied when making any warranty claim to your OSBURN dealer.

**This warranty applies to normal residential use only. Damages caused by misuse, abuse, improper installation, lack of maintenance, over firing, negligence or accident during transportation, power failures, downdrafts, venting problems or underestimated heating area are not covered by this warranty. The recommended heated area for a given appliance is defined by the manufacturer as its capacity to maintain a minimum acceptable temperature in the designated area in case of a power failure.**

This warranty does not cover any scratch, corrosion, distortion, or discoloration. Any defect or damage caused by the use of unauthorized or other than original parts voids this warranty. An authorized qualified technician must perform the installation in accordance with the instructions supplied with this product and all local and national building codes. Any service call related to an improper installation is not covered by this warranty.

The manufacturer may require that defective products be returned or that digital pictures be provided to support the claim. Returned products are to be shipped prepaid to the manufacturer for investigation. Transportation fees to ship the product back to the purchaser will be paid by the manufacturer. Repair work covered by the warranty, executed at the purchaser's domicile by an authorized qualified technician requires the prior approval of the manufacturer. All parts and labour costs covered by this warranty are limited according to the table below.

The manufacturer, at its discretion, may decide to repair or replace any part or unit after inspection and investigation of the defect. The manufacturer may, at its discretion, fully discharge all obligations with respect to this warranty by refunding the wholesale price of any warranted but defective parts. The manufacturer shall, in no event, be responsible for any uncommon, indirect, consequential damages of any nature, which are in excess of the original purchase price of the product. A one-time replacement limit applies to all parts benefiting from lifetime coverage. This warranty applies to products purchased after June 1<sup>st</sup>, 2015.

DESCRIPTION	WARRANTY APPLICATION*	
	PARTS	LABOUR
Combustion chamber (welds only) and cast iron door frame.	Lifetime	5 years
Ceramic glass (thermal breakage only**), plating (manufacturing defect**) and convector air-mate.	Lifetime	N/A
Surrounds, heat shields, ash drawer, steel legs, pedestal, trims (aluminum extrusions), C-Cast baffle**, vermiculite baffle**, secondary air tubes**, removable stainless steel combustion chamber deflectors and supports.	7 years	N/A
Handle assembly, glass retainers and air control mechanism.	5 years	3 years
Removable carbon steel combustion chamber components.	5 years	N/A
Standard and optional blower, heat sensors, switches, rheostat, wiring and electronics.	2 years	1 year
Paint (peeling**), gaskets, insulation, ceramic fiber blankets, firebricks and other options.	1 year	N/A
All parts replaced under the warranty.	90 days	N/A

**\*Subject to limitations above. \*\*Picture required.**

Labour cost and repair work to the account of the manufacturer are based on a predetermined rate schedule and must not exceed the wholesale price of the replacement part.

Shall your unit or a components be defective, contact immediately your **OSBURN** dealer. To accelerate processing of your warranty claim, make sure to have on hand the following information when calling:

- |  |  |
|--|--|
| Your name, address and telephone number; | Serial number and model name as indicated on the   |
| Bill of sale and dealer's name;          | nameplate fixed to the back of your unit;          |
| Installation configuration;              | Nature of the defect and any relevant information. |

**Before shipping your unit or defective component to our plant, you must obtain an Authorization Number from your OSBURN dealer. Any merchandise shipped to our plant without authorization will be refused automatically and returned to sender.**