

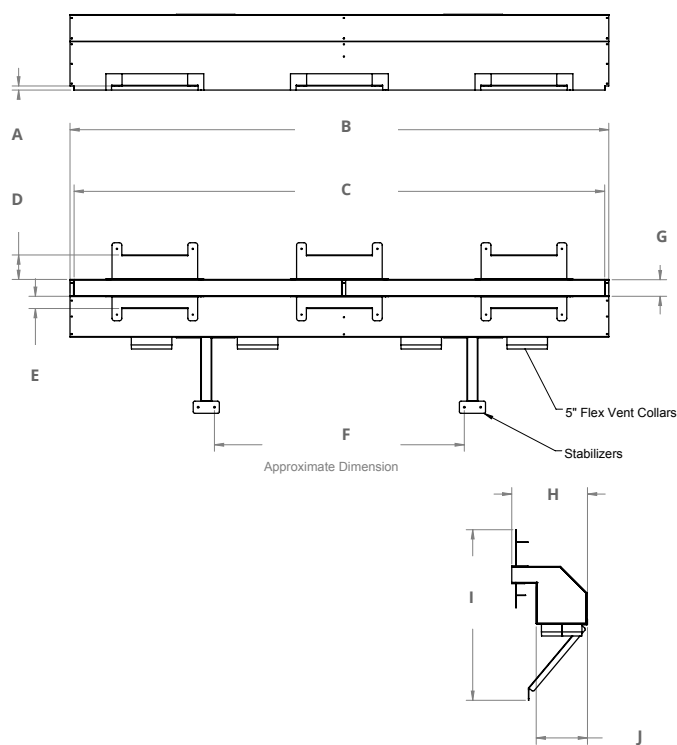

**HDKPD63, HDKPD72
COOL WALL ADVANTAGE TV KIT**

- 24' of 5" diameter flex pipe required for completion of installation. Flex pipe is available from Montigo as part # HDKPDFK.
- The installation of this fireplace must be done by a qualified and certified gas appliance installer.
- Check local codes and read all instructions prior to installation.
- See installation manual for clearances to combustibles
- Minimum clearance to flexible ducting is 1"



HDKPD63, HDKPD72 DIMENSIONS

	A	B	C	D	E	F	G	H	I	J
63"	1/2"	66 1/16"	65 1/16"	3"	1 1/2"	30 5/8"	2"	9 5/16"	20 15/16"	6 5/16"
72"	1/2"	75 13/16"	74 13/16"	3"	1 1/2"	39 7/16"	2"	9 5/16"	21"	7 1/16"

Assembly

1 Unscrew Cap and replace with supplied Crimp Collars using the same hardware.

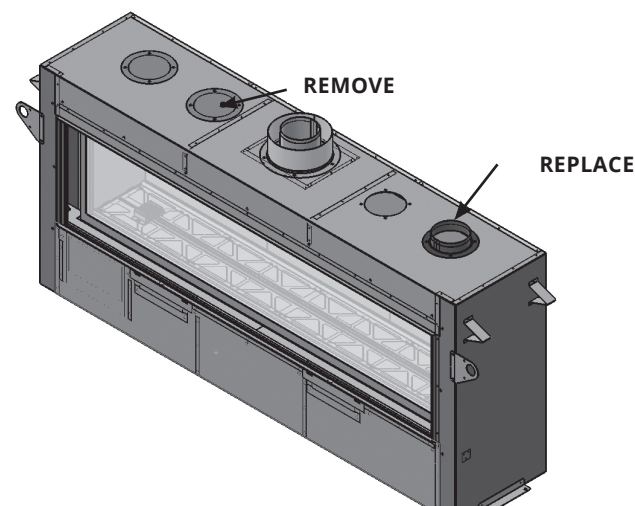

2 Secure Heat Distribution kit to Framing at Desired Height and use supplied crimp collars to secure ducting. If using Montigo Flex Pipe Kit HDKPD63FK please ensure that the pipe is fully extended before cutting to desired length. Montigo flex pipe can be stretched 50% (e.g. 6' pipe can be stretched to 9')

Maintain 1" Clearance to combustibles from flex pipe.

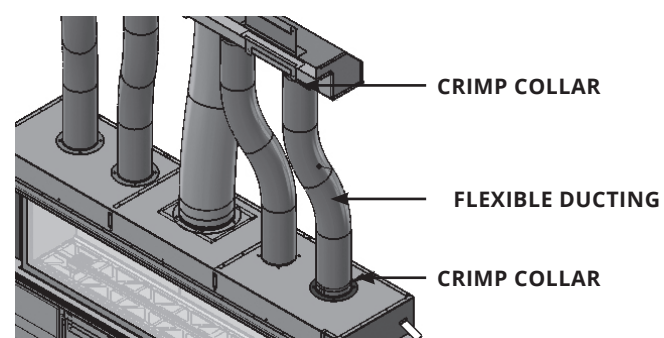

3 Install boards A and B first then secure the TV kit with the lower screws. Boards B will be cut to length depending on the height of the Heat Distribution Kit. Then install the upper board C to secure the Heat Distribution Kit.

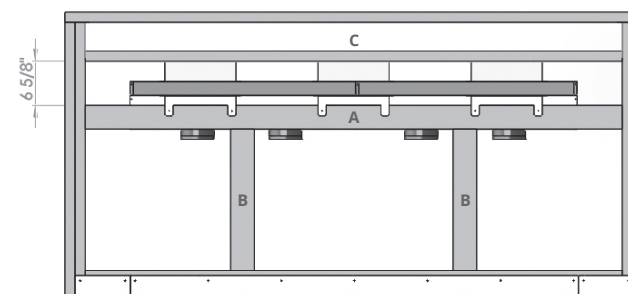

4 The opening should be a minimum of 33" from the top of the fireplace and a minimum of 3" from the ceiling. Secure with 12 wood screws (not provided)

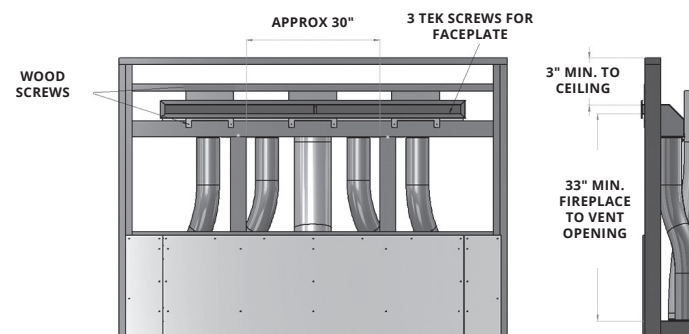

5 Insert Brace to secure unit to stud frame

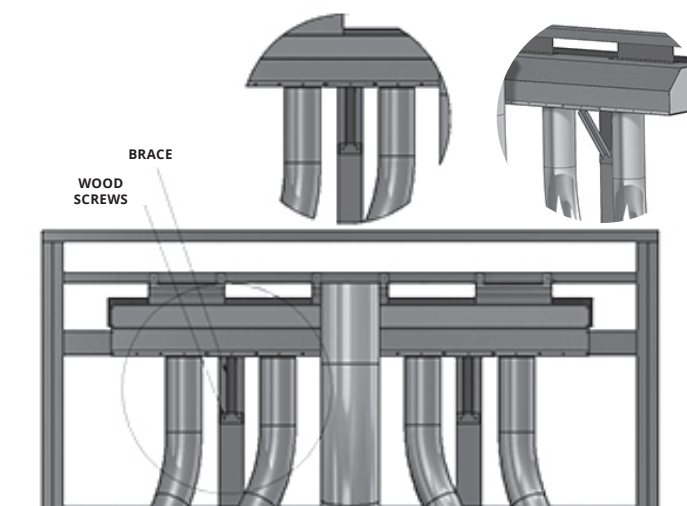

NOTICE

Installer: Leave this manual with the appliance.
Consumer: Retain this manual for future reference.

Finishing

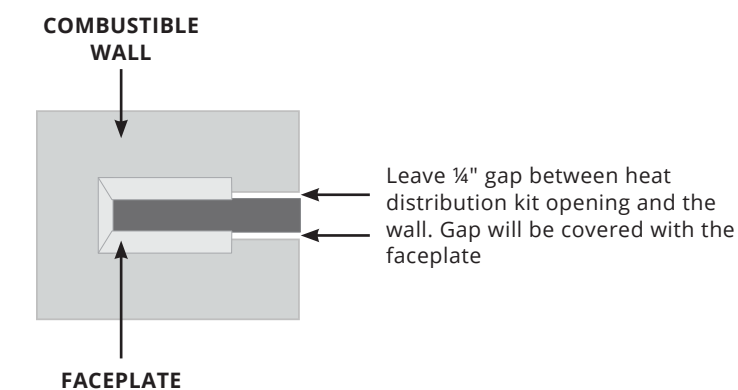



HDKSD COOL WALL ADVANTAGE SIDE DISCHARGE KIT

NOTICE

Installer: Leave this manual with the appliance.
 Consumer: Retain this manual for future reference.

- 24' of 5" diameter flex pipe required for completion of installation. Flex pipe is available from Montigo as part # HDKPDFK.
- The installation of this fireplace must be done by a qualified and certified gas appliance installer.
- Check local codes and read all instructions prior to installation.
- See installation manual for clearances to combustibles materials
- Minimum clearance to flexible ducting is 1"

HDKSD DIMENSIONS

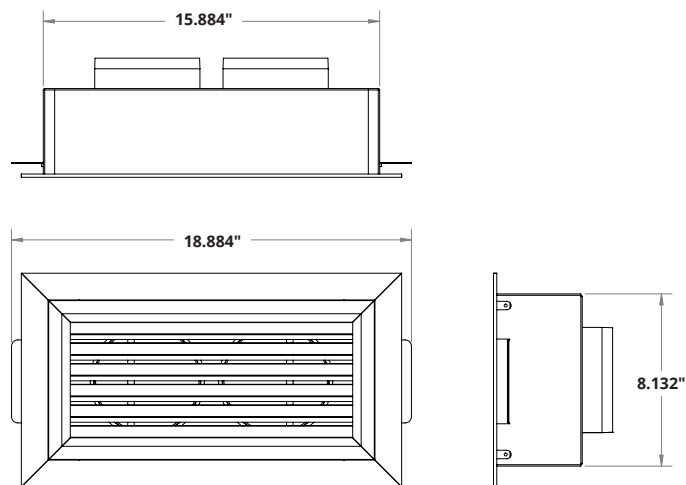

Assembly

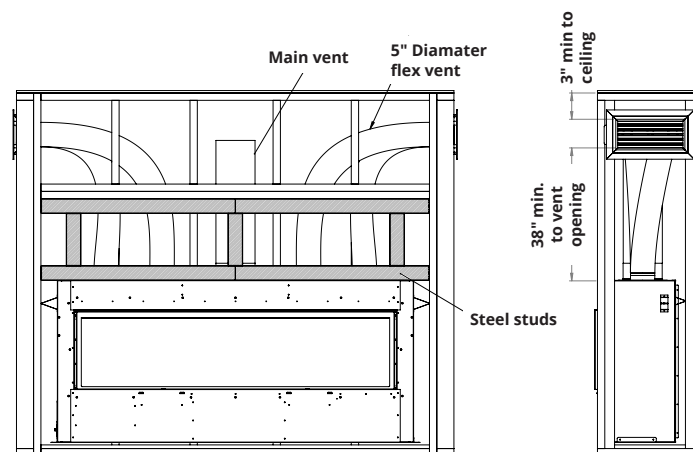

⚠ WARNING

Some materials used in the manufacturing process of this product can expose you to Benzene which is known in the State of California to cause cancer and birth defects or other reproductive harm. For more information go to www.P65warnings.ca.gov