



# SENTINEL

FREE STANDING DIRECT VENT GAS STOVE

 marquis  
COLLECTION

Unit Illustrated: FDV350N Direct Vent Natural Gas Stove, F35DB Black Door and Ceramic Glass, LOGF35 Fibre Oak Log Set with Embers.

Direct Vent Free Standing Stove; a safe and efficient heating appliance with the convenience of gas. Your best choice for installation anywhere throughout your home.

## DIMENSIONS AND SIZING

With a direct vent appliance you can vent either through the side wall above the unit or straight up through the roof.

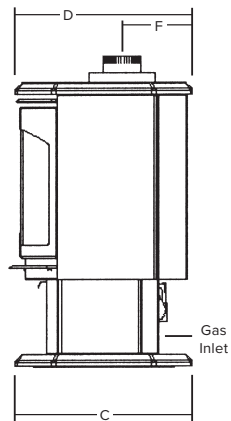
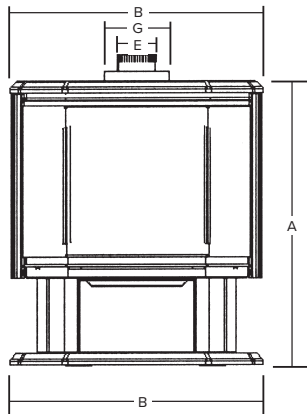

### FDV350

- A 30 3/8"
- B 27 5/16"
- C 19 1/16"
- D 19 1/16"
- E 4" dia.
- F 7 1/2"
- G 7" dia.

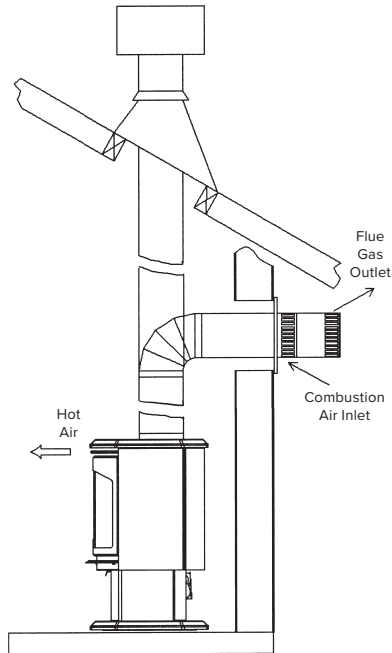

## STANDARD FEATURES

- Millivolt Valve with Hi-Low heat and flame adjustment and allows operation during a power failure
- Proflame II (PF2) Models include Remote Control – Features flame, fan, thermostat, smart thermostat and battery backup
- Dual burner system, with realistic flame pattern
- Heat radiating ceramic glass with panoramic view from three sides
- Mobile home approved
- Approved for installation in a bedroom or bed sitting room
- Black Louver
- Fibre Oak Log Set with Embers\*

## OPTIONAL FEATURES

**Fan Kit:** Heat activated with variable speed control

**Brick Refractory Liner**

**Thermostat:** Wall Mount Millivolt Thermostat or Programmable Thermostat

**Remote Control (Millivolt):** On/Off, Thermostat On/Off, Thermostat On/Off modulating, Thermostat On/Off modulating

**B-Vent Adapter (Convert Stove to 4" B-Vent)**

## MINIMUM CLEARANCES TO COMBUSTIBLES

- 12" from side of unit
- 3" from back of unit
- 3" from side of unit in corner

## ALCOVE INSTALLATION

- 30" depth (max.)
- 55 1/2" height (min.)
- 52 1/2" width (min.)

Model	FDV350N / FDV350NE2	FDV350LP / FDV350LPE2
Fuel	Natural	Propane
Input Max	37,000 BTU	35,000 BTU
Input Min.	29,000 BTU	27,000 BTU
FE (P.4.1-15)	66.63% / 67.47%	69.33% / 70.17%

## LOG SET



LOGF35  
Fibre Oak with Embers

## SAFETY SCREEN BARRIER



## REMOTE CONTROLS



Marquis Fireplaces maintains a program of continuous testing, refinement and improvements of all its products. Some aspect of units shown here may be changed at any time without notice or obligation.

Certified for USA and Canada to: ANSI Z21.88-2017 / CSA 2.33-2017, CSA 2.17-2017

Note: Components may have to be ordered separately to create a complete unit. Discuss with your local Marquis Dealer for clarification.



### FOR CALIFORNIA RESIDENTS ONLY:

**WARNING!** This product can expose you to chemicals including Carbon Monoxide, that is an externally vented by-product of fuel consumption, which is [are] known to the State of California to cause birth defects or other reproductive harm. For more information, visit [www.P65Warnings.ca.gov](http://www.P65Warnings.ca.gov).

Crafted entirely in Canada, each Marquis fireplace is built to the highest standards and made to last.



LIMITED LIFETIME WARRANTY

2340 Logan Avenue  
Winnipeg, Manitoba, CAN  
R2R 2V3  
Phone: 204.632.1962  
Fax: 204.632.1960  
[marquisfireplaces.net](http://marquisfireplaces.net)

Printed in Canada  
B070 – 10/18