

Linea 60



DRAMATIC FIRE

Our **Linea** is a stunning addition to an outdoor living area. Its long line of modern fire creates a stunning visual display and still keeps a comfortable 5" of table space all around. This unit is perfect either for an entertainment space or to create a space divider.

Product Features/ Specifications:

- 65K BTU and 190K BTU
- Liquid Propane or Natural Gas
- Complimentary Lava Rocks
- Other media available for purchase
- Manual Lit Ignition (available for upgrade to Electronic Ignition - please contact for further information)
- Weight: 305 lbs.
- Overhead clearance: 84" - 120" (depending on burner) and 36" horizontally to combustibles.

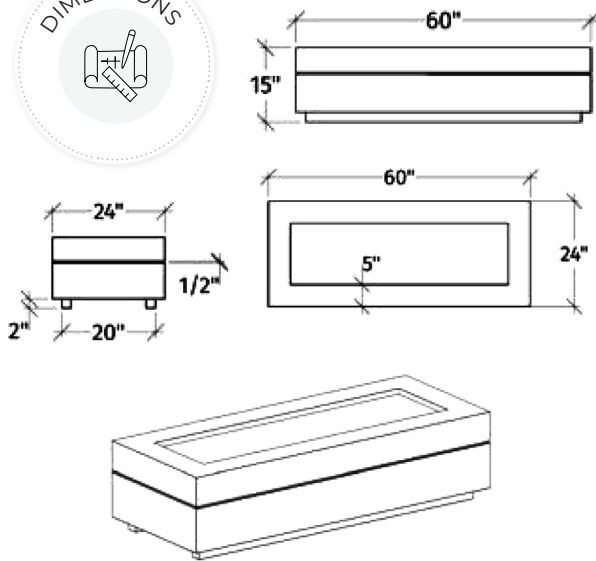
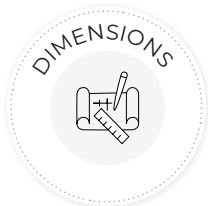

Min. and Max. Gas Inlet Pressures:

The installer is responsible for using the correct fuel lines and/or regulation to provide gas to the fire feature within the specified minimum and maximum gas inlet pressures.

Gas Inlet Pressures

MATCH LIGHT	Minimum	Maximum
Natural Gas	3.5" W.C. (.8718 Kpa)	7.0" W.C. (1.7436 Kpa)
Liquid Propane	11.0" W.C. (2.7399 Kpa)	13.0" W.C. (3.2381 Kpa)