

- Installation Instructions -

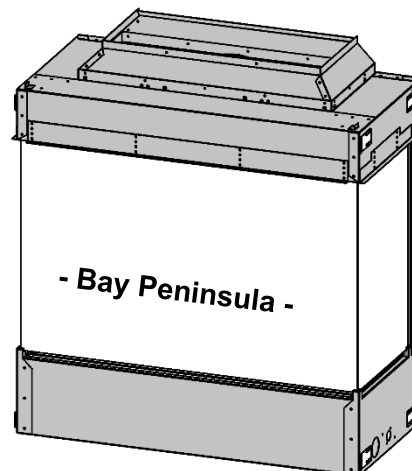

Model Numbers: MQZCVBG34NE2, MQZCVBG34LPE2

Certified to: CSA/ANSI Z21.88:19 • CSA 2.33:19
and CSA 2.17-2017
VENTED GAS FIREPLACE HEATERS



⚠ WARNING:

FIRE OR EXPLOSION HAZARD

Failure to follow safety warnings exactly could result in serious injury, death, or property damage.

-Do not store or use gasoline or other flammable vapors and liquids in the vicinity of this or any other appliance.

-WHAT TO DO IF YOU SMELL GAS

- Do not try to light any appliance.
- Do not touch any electrical switch; do not use any phone in your building.
- Leave the building immediately.
- Immediately call your gas supplier from a neighbor's phone. Follow the gas supplier's instructions.
- If you cannot reach your gas supplier, call the fire department

-Installation and service must be performed by a qualified installer, service agency or the gas supplier.

INSTALLER: Leave this manual with the appliance. **CONSUMER:** Retain this manual for future reference.

This appliance may be installed in an aftermarket, permanently located, manufactured home (USA only) or mobile home, where not prohibited by local codes.

This appliance is only for use with the type of gas indicated on the rating plate. This appliance is not convertible for use with other gases, unless a certified kit is used.

⚠ WARNING: do not operate this appliance without decorative glass embers on burner and media tray.

**VENTED GAS FIREPLACE HEATER:
NOT FOR USE WITH SOLID FUEL**

IT IS THE RESPONSIBILITY OF THE HOME OWNER TO ENSURE THAT NO ONE TOUCHES A HOT APPLIANCE.

- If the barrier becomes damaged, the barrier shall be replaced with the manufacturer's barrier for this appliance.
- Any safety screen, guard, or barrier removed for servicing the appliance, must be replaced prior to operating the appliance.
- Children and adults should be alerted to the hazards of the high surface temperatures of this appliance and should stay away to avoid burns or ignition of clothing.
- Do not clean when the glass is hot.
- Young children should be carefully supervised when they are in the same room as the appliance. Toddlers, young children and others may be susceptible to accidental contact burns.
- A physical barrier is recommended if there are at risk individuals in the house. To restrict access to a fireplace or stove, install an adjustable safety gate to keep toddlers, young children and other at risk individuals out of the room and away from hot surfaces.
- Do not leave the fireplace remote control where it is accessible to children.



DANGER



HOT GLASS WILL CAUSE BURNS.

DO NOT TOUCH GLASS UNTIL COOLED.

NEVER ALLOW CHILDREN TO TOUCH GLASS.

A barrier designed to reduce the risk of burns from the hot viewing glass is provided with this appliance and must be installed for the protection of children and other at-risk individuals.

If the barrier becomes damaged, the barrier must be replaced with the manufacturer's barrier for this appliance.



WARNING:

A HORIZONTAL VENT CERTIFIED GUARD (SAFETY CAGE) IS AVAILABLE WHEN REQUIRED BY LOCAL CODES.

SAFETY CAGES ARE AVAILABLE FOR ALL HORIZONTAL VENT TERMINATIONS. CHECK WITH YOUR DEALER.

- **TERMINATION CAP IS HOT!** Do not place flammable materials on or within 24 inches of termination caps.
- It is imperative that the vent termination be located observing the minimum clearances as shown in manual.
- There must not be any obstruction such as bushes, garden sheds, fences, decks or utility buildings within 24" from the front of the termination plate.
- Do not locate termination where excessive snow or ice build-up may occur. Be sure to check vent termination area after snow falls and clear to prevent accidental blockage of venting system. When using snow blowers, make sure snow is not directed towards vent termination area.
- Venting terminal shall not be recessed into a wall or siding.

| | |
|--|-------|
| Hot Glass & Vent Termination Warnings..... | 2 |
| Table of Contents..... | 3-4 |
| Warnings, Installations and Operations - Installation Regulations..... | 5 |
| Installation Requirements for the Commonwealth of Massachusetts..... | 6 |
| Carbon Monoxide (CO) Detector..... | 6 |
| Pre-installation Questions and Answers..... | 7 |
| Operations and Maintenance Instructions..... | 7 |
| Mobile Home/Manufactured Housing Installation..... | 8 |
| Installation & Framing | |
| Framing Your Gas Fireplace..... | 9 |
| Stand-off and Nailing Tab Locations..... | 9 |
| Nailing Tab Guide..... | 10 |
| Locating Your Appliance..... | 11 |
| Fireplace Dimensions..... | 11 |
| Vented Chase Requirements, Options, and Framing | |
| Vented Chase Requirements..... | 12 |
| Vented Chase Opening Options..... | 12 |
| Framing Dimensions- Full Chase with Front -OR- Side Grills..... | 13 |
| Framing Dimensions- Full Chase with Open Top..... | 14 |
| Framing Dimensions- Recessed Front Chase with Front Grill..... | 15 |
| Framing Dimensions- Recessed Front Chase with Open Top..... | 16 |
| Framing Dimensions- Recessed Front and Side Chase Open Top..... | 17 |
| Framing Dimensions- Corner Framing-Full Chase with Open Top..... | 18 |
| Framing Dimensions- Corner Framing-Recessed Front Chase with Open Top..... | 19 |
| Framing Dimensions- Corner Framing- Recessed Front and Side Chase- Open Top..... | 20 |
| Mantel and Adjacent Wall Clearances..... | 21 |
| Clearance to Combustibles..... | 22 |
| V34EG Grill Installation..... | 23 |
| V34EGS Side Grill Installation..... | 24 |
| Facing Requirements..... | 25 |
| Using Upper Tile Lips (supplied with unit)..... | 25 |
| ZCV34BGCK Corner Kit- Optional..... | 26-29 |
| General Information | |
| Side Glass Removal and Installation..... | 30 |
| Front Glass Installation and Removal..... | 31 |
| Glass Door Information..... | 32 |
| Glass Safety Barrier Installation / Removal..... | 33 |
| Component Locations..... | 34 |
| Accessories and Options | |
| 34ZCVBG-TLK Tile Lip Kit..... | 35 |
| Halogen Lighting Kit ULK5-2..... | 36-37 |
| Glass Back Liner Installation..... | 38 |
| Glass Side Liner Installation..... | 39 |
| Refractory Back Liner Installation..... | 40 |
| Refractory Side Liner Installation..... | 41 |
| Media Options | |
| Crushed Glass and Media Options..... | 42 |
| MQROCK2, MQROCK3..... | 43 |
| MQ STONE Decorative Stone Set..... | 43 |
| MQEMBER..... | 43 |
| RBCB1 Cannonballs..... | 44 |
| MQLOGF453 Driftwood Log Set..... | 45 |
| MQRBD3 Driftwood Log Set..... | 46 |
| MQRBRW Birch Log Set..... | 47 |

| | |
|--|-------|
| MQ42D Driftwood Log Set..... | 48 |
| MQLOGF34BW Birch Log Set..... | 49 |
| MQLOGF34OAK Oak Log Set..... | 50 |
| MQLOGF34BW & MQLOGF34OAK Setup Instructions..... | 51 |
| Gas Line Installation, Use, and Maintenance | |
| Gas Line Installation / Gas Specifications Chart..... | 52 |
| Annual Inspection List..... | 53 |
| Troubleshooting the Gas Control System..... | 54 |
| Burner System Maintenance..... | 55 |
| Gas Conversion Part A..... | 56 |
| Gas Conversion Part B - Top Convertible SIT Pilot..... | 57 |
| Gas Conversion Part C - SIT Valve and Modulator..... | 58 |
| Burner System Removal and Installation..... | 59 |
| Lighting Instructions- IPI..... | 60 |
| Proflame 2 IPI System | |
| Parts List..... | 61 |
| Proflame 2 IFC Module and Remote Control..... | 62 |
| Cold Climates – CPI Setting..... | 63 |
| Proflame 2 Remote Control..... | 64-65 |
| Proflame 2 Schematic..... | 66 |
| WMBH – Wall Mount Battery Holder - Option..... | 67 |
| Venting | |
| Vent Terminal Clearances..... | 68 |
| General Vent Installation..... | 69 |
| Installation of Side Wall Venting..... | 70 |
| Venting Routes and Components..... | 71 |
| Horizontal Venting Table..... | 71 |
| Flue Restrictor..... | 72 |
| Venting Straight Up Through Roof..... | 73-74 |
| Venting - Cathedral Ceiling..... | 75 |
| Co Linear Flex Kits..... | 76 |
| Approved for Power Vent | 77 |
| Parts Lists | |
| Power Vent Parts List..... | 78 |
| MQZCVBG34 Parts List..... | 79-80 |
| Warranty | |
| Limited Lifetime Warranty..... | 81 |

Warnings, Installations and Operations - Installation Regulations

This gas appliance must be installed by a qualified installer in accordance with local building codes, or in the absence of local codes, with the current CAN/CSA-B149.1 or .2 Installation Code (in Canada) or the current National Fuel Gas Code Z223.1- NFPA 54 when installed in the United States. This appliance, when installed, must be electrically connected and grounded in accordance with local codes, or in the absence of local codes, with the current CSA C22.1 Canadian Electrical Code or with the National Electrical Code; ANSI/NFPA 70 when installed in the United States.



FOR SAFE INSTALLATION AND OPERATION OF YOUR GAS FIREPLACE PLEASE NOTE THE FOLLOWING:

1. Do not clean when the glass is hot.
2. Do not use abrasive cleaners.
3. Using a substitute glass will void all product warranties.
4. For safe operation, glass doors must be closed.
5. When purging the gas line, the glass front must be removed.
6. Do not strike or abuse glass. Take care to avoid breakage.
7. Do not alter gas orifice.
8. No substitute materials may be used other than factory supplied components.
9. This appliance gives off high temperatures and should be located out of heavy traffic areas and away from furniture and draperies.
10. Children and adults should be alerted to the hazards of the high surface temperatures of this appliance and should stay away to avoid burns or ignition of clothing.
11. Young children should be carefully supervised when they are in the same room as the appliance. Toddlers, young children and others may be susceptible to accidental contact burns. A physical barrier is recommended if there are at risk individuals in the house. To restrict access to a fireplace or stove, install an adjustable safety gate to keep toddlers, young children and other at risk individuals out of the room and away from hot surfaces.
12. Under no circumstances should any solid fuels (wood, paper) be used in this appliance.
13. Under no circumstances should this appliance be modified. Any parts that have to be removed for servicing should be replaced prior to operating this appliance.
14. Any safety screen, guard, or barrier removed for servicing an appliance must be replaced prior to operating the appliance.
15. Installation and repair should be done by a qualified service person. The appliance should be inspected before use and at least annually by a professional service person. More frequent cleaning may be required due to excessive lint from carpeting, bedding material, et cetera. It is imperative that control compartments, burners and circulating air passageways of the appliance be kept clean. Make sure that the gas valve and pilot light are turned off before you attempt to clean this unit.
16. Clothing or other flammable material should not be placed on or near the appliance. This appliance should not be used as a drying rack for clothing nor should Christmas stockings or decorations be hung from it.
17. Do not use this heater if any part has been under water. Immediately call a qualified service technician to inspect the heater and to replace any part of the control system and any gas control which has been under water.
18. Do not operate appliance unless completely installed as per installation instructions.
19. Failure to position the parts in accordance with these diagrams or failure to use only parts specifically approved with this appliance may result in property damage or personal injury.
20. **WARNING: Do not operate appliance with the glass front removed, cracked or broken. Replacement of the glass should be done by a licensed or qualified service person.**
21. The appliance area must be kept clear and free from combustible materials, gasoline, and other flammable vapors and liquids.
22. The front of the fireplace gives off high temperatures that could ignite combustible material which is kept close to the front of the unit.
23. Ensure that power to the Fireplace is turned off before servicing.
24. Do not operate this Fireplace without the glass front or with a broken glass.
25. Improper installation, adjustment, alteration, service or maintenance can cause injury or property damage. Refer to the owner's information manual provided with this appliance. For assistance or additional information consult a qualified installer, service agency, or the gas supplier.
26. Operation of this appliance when not connected to a properly installed and maintained venting system or tampering with the blocked vent shutoff system can result in carbon monoxide (CO) poisoning and possible death.
27. This appliance is equipped with a three-prong (grounding) plug for your protection against shock hazard and should be plugged directly into a properly grounded three-prong receptacle. Do not cut or remove the grounding prong from this plug.
28. **NOT INTENDED FOR USE AS A PRIMARY HEAT SOURCE.** This appliance is tested and approved as either supplemental room heat or as a decorative appliance. It should not be factored as primary heat in residential heating calculations.
29. This appliance must not be connected to a chimney flue serving a separate solid-fuel burning appliance.
30. Remove all loose materials from the appliance (manual, remote control, etc.) before connecting gas and electricity.
31. Ensure that the remote control is "OFF" before connecting gas and electricity to the appliance.

Installation Requirements for the Commonwealth of Massachusetts

In the Commonwealth of Massachusetts, the installer or service agent shall be a plumber or gas fitter licensed by the Commonwealth.

When installed in the Commonwealth of Massachusetts or where applicable codes; the unit shall be installed with a CO detector per the requirements listed below.

1. For direct-vent appliances, mechanical-vent heating appliances or domestic hot water equipment, where the bottom of the vent terminal and the air intake is installed below four feet above grade the following requirements must be satisfied:
 - A. If there is not one already present, on each floor level where there are bedroom(s), a carbon monoxide detector and alarm shall be placed in the living area outside the bedroom(s). The carbon monoxide detector shall comply with NFPA 720.
 - B. A carbon monoxide detector shall be located in the room that houses the appliance or equipment and shall:
 - Be powered by the same electrical circuit as the appliance or equipment such that only one service switch services both the appliance and the carbon monoxide detector;
 - Have battery back-up power;
 - Meet ANSI./UL 2034 Standards and comply with NFPA 720; and
 - Have been approved and listed by a Nationally Recognized Testing Laboratory as recognized under 527 CMR.
 - C. A Product-approved vent terminal must be used, and if applicable, a Product-approved air intake must be used. Installation shall be in strict compliance with the manufacturer's instructions. A copy of the installation instructions shall remain with the appliance or equipment at the completion of the installation.
 - D. A metal or plastic identification plate shall be mounted at the exterior of the building, four feet directly above the location of vent terminal. The plate shall be of sufficient size to be easily read from a distance of eight feet away, and read "Gas Vent Directly Below".
2. For direct-vent appliances, mechanical-vent heating appliances or domestic hot water equipment where the bottom of the vent terminal and the air intake is installed above four feet above grade the following requirements must be satisfied:
 - A. If there is not one already present, on each floor level where there are bedroom(s), a carbon monoxide detector and alarm shall be placed in the living area outside the bedroom(s). The carbon monoxide detector shall comply with NFPA 720.
 - B. A carbon monoxide detector shall:
 - Be located in the room that houses the appliance or equipment;
 - Be either hard-wired or battery powered or both; and
 - Shall comply with NFPA 720.

A Product-approved vent terminal must be used, and if applicable, a Product-approved air intake must be used. Installation shall be in strict compliance with the manufacturer instructions. A copy of the installation instructions shall remain with the appliance or equipment at the completion of the installation.

For the state of Massachusetts a **T-handle gas shut-off valve** must be used on a gas appliance. This T-handle gas shut-off valve must be listed and approved by the state of Massachusetts. This is in reference to the state of Massachusetts state code CMR238.

Carbon Monoxide (CO) Detector

NOTE: It is recommended that a Carbon Monoxide (CO) Detector be installed in or near bedrooms and on all levels of your home. Place a detector about 15ft [4.5m] outside the room that houses your gas appliance.

Certified for installation in a bedroom or bed/sitting room. In Canada must be installed with listed millivolt thermostat. In USA see local codes.



WARNING

This product and the fuels used to operate this product (liquid propane or natural gas), and the products of combustion of such fuels, can expose you to chemicals including benzene, which is known to the State of California to cause cancer and reproductive harm. For more information go to: www.P65Warnings.ca.gov.

Pre-installation Questions and Answers

About curing of the paint

Your stove or fireplace has been painted with the highest quality silicone stove paint. This paint dries quickly in 15-20 minutes when first applied at the factory. However, due to the high temperature silicone components, the paint will cure when heat is applied to the appliance as it is first used. The following information applies to the curing process to get the paint fully hard and durable. **Note: Use of painter's tape is not recommended, as it may damage the paint.**

Fire the appliance four successive times for 10 minutes each firing and a 5 minute cool down between each. Be aware during log and firebox paint curing that a white deposit may be developing on the inside of the glass doors. It is important to remove this white deposit from the glass doors using a fireplace glass cleaner.

- Babies, small children, pregnant women and pets should leave the area during the cure phase.
- Ventilate well, open doors and windows.
- Do not touch during curing.

Why does my fireplace or stove give off odor?

It is normal for your fireplace to give off some odor at first. This is due to the curing of the paint, adhesives, silicones and any undetected oil from the manufacturing process as well as the finishing materials used with the installations (e.g. marble, tile and the adhesives used to adhere this product to the walls can react with heat and cause odors).

It is recommended that you burn your gas fireplace or stove for a minimum of four hours at a time with the fan off (if a fan is present) after the curing of the paint has been completed. These odors can last upward to 40 hours of burn time; keep burning at a minimum of four hours per use until odors dissipate.

Noise coming from the fireplace?

Noise is caused by the expansion and contraction of metal as the appliance heats up and cools down. This is normal and is similar to the sounds produced by a furnace or heating duct. This noise does not affect the operation or longevity of your fireplace.

It is also normal for the fan to make some noise when it comes on. This noise can be reduced somewhat by turning down the speed of the fan with the variable speed control. Be aware, however, that this will reduce the volume of heated air circulated into the room by the fan.

Note to the Installer:

Be sure appliance is working properly and its operation (including remote control operation, if included) is fully explained to and understood by the customer.

Operations and Maintenance Instructions

For safe installation and operation note the following:

- Be sure to read and understand all the instructions in this manual before operation of appliance.
- Ensure all wiring is correct and properly enclosed to prevent possible shock.
- Check for gas leaks.
- Make sure the glass door is properly installed before operation. Never operate the appliance with the glass door removed.
- Make sure venting and termination cap are installed and unobstructed.
- If brick or porcelain liners are used, ensure they are installed.
- Verify that the pilot can be seen when lighting the appliance. If not, the log or rock placement is incorrect.
- If the unit is turned off, you must wait a minimum of 60 seconds before re-lighting it.
- Venting systems should be periodically examined by a qualified agency.
- The flow of combustion and ventilation air must not be obstructed.
- The Burner/Log Assembly has been engineered and permanently adjusted for proper flame control.
- Periodically remove the logs from the grate assembly and vacuum any loose particles from the grate and burner areas. See Log Placement page to remove logs. Vacuum burner parts and replace logs.
- Never use your gas fireplace as a cooking device.
- Label all wires prior to disconnection when servicing controls. Wiring errors can cause improper and dangerous operation. Verify proper operation after servicing.
- Areas in and around the Chase Vent Openings should be cleaned annually.

Mobile Home/Manufactured Housing Installation

This Direct Vent System Appliance must be installed in accordance with the manufacturer's installation instructions and the Manufactured Home Construction and Safety Standard Title 24 CFR, Part 3280, or the current Standard for Fire Safety Criteria for Manufactured Home Installations, Sites, and Communities ANSI/NFPA 501A, and with CAN/CSA Z240 MH Mobile Home Standard in Canada.

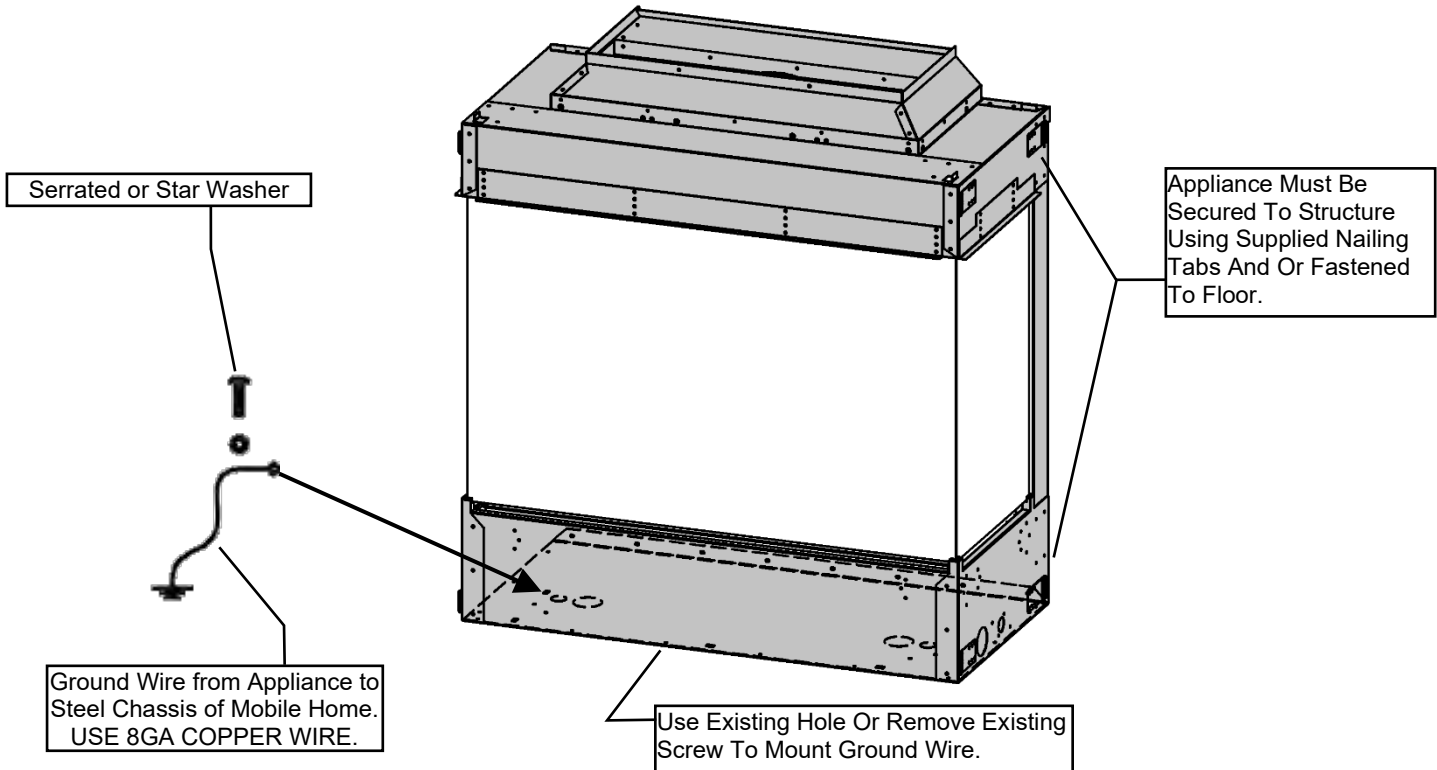

THE VENTED GAS FIREPLACE HEATERS (ANSI Z21.88) IN THIS MANUAL MAY BE INSTALLED IN MANUFACTURED (MOBILE) HOMES AFTER FIRST SALE IN THE USA.

THE VENTED GAS FIREPLACE HEATERS IN THIS MANUAL MAY BE INSTALLED IN MANUFACTURED (MOBILE) HOMES IN CANADA.

Please follow the current ANSI/NFPA 70 National Electrical Code in the USA and CAN/CSA C22.1 Canadian National Electrical Code in Canada.

An appliance must be grounded to the steel chassis of the home with 8 ga. copper wire using a serrated or star washer to penetrate paint or protective coating to insure grounding. Use carriage bolt at the attachment point (see diagram above) to secure the appliance to the floor.



Warning: Do not compromise the structural integrity of the manufactured home wall, floor or ceiling, during installation of appliance or venting.

For required venting components see venting installation in appropriate section of this manual.

Certified for installation in a bedroom or bed/sitting room. In Canada must be installed with listed millivolt thermostat. In USA see local codes.

Framing Your Gas Fireplace

This section is intended for qualified installers only. Before beginning, make note of where the gas and electrical accesses are located on the unit. This will streamline the construction process. Furthermore, familiarize yourself with the venting and clearance requirements (see Venting section) for this appliance. Failure to comply with those requirements can seriously compromise the safety and operation of the fireplace.

Specifications

1. Cold climate installation recommendation: When installing this fireplace against non-insulated exterior wall or chase, it is recommended that the outer walls be insulated to conform to applicable insulation codes. Drywall & vapor barrier must be installed over insulation to prevent contact of insulation and unit.
2. Choose fireplace location and frame in accordance with the fireplace framing dimensions specified (view diagrams).
3. Drywall or other combustible material can extend up to the Drywall Stops located on the sides of the unit, and up to the bottom and top.
4. A Hearth is not required for this unit.

Vertical Venting in Cold Climates

In cold climate conditions where temperatures go below -10 degrees Celsius or 14 degrees Fahrenheit, we recommend that the chase be insulated and where the vent pipe enters into the attic space that the pipe be wrapped with an insulated Mylar sleeve. This will increase the temperature of the vent and help the appliance to vent properly in cold weather conditions.

It is also important in vertical vented direct vent appliances that the appliance be operated daily during the winter months as this will help stop the termination from freezing up. We recommend using a set at room temperature to allow the unit to cycle.

For IPI models it may be necessary to set the appliance to Standing Pilot mode to maintain heat in the cavity. The purpose of this procedure is to prevent cold air from penetrating the chimney and then onto the living space. Therefore, when the internal temperature is slightly elevated the fireplace is able to freely exhaust its combustion and hence making it easier to startup.

Certified for installation in a bedroom or bed sitting room. In Canada must be installed with listed millivolt thermostat. In USA see local codes.

Stand-off and Nailing Tab Locations

Make note of where the stand-off locations are. These stand-offs are provided as indicators to illustrate the boundaries for framing. Therefore, no framing material is permitted to extend beyond these stand-offs.

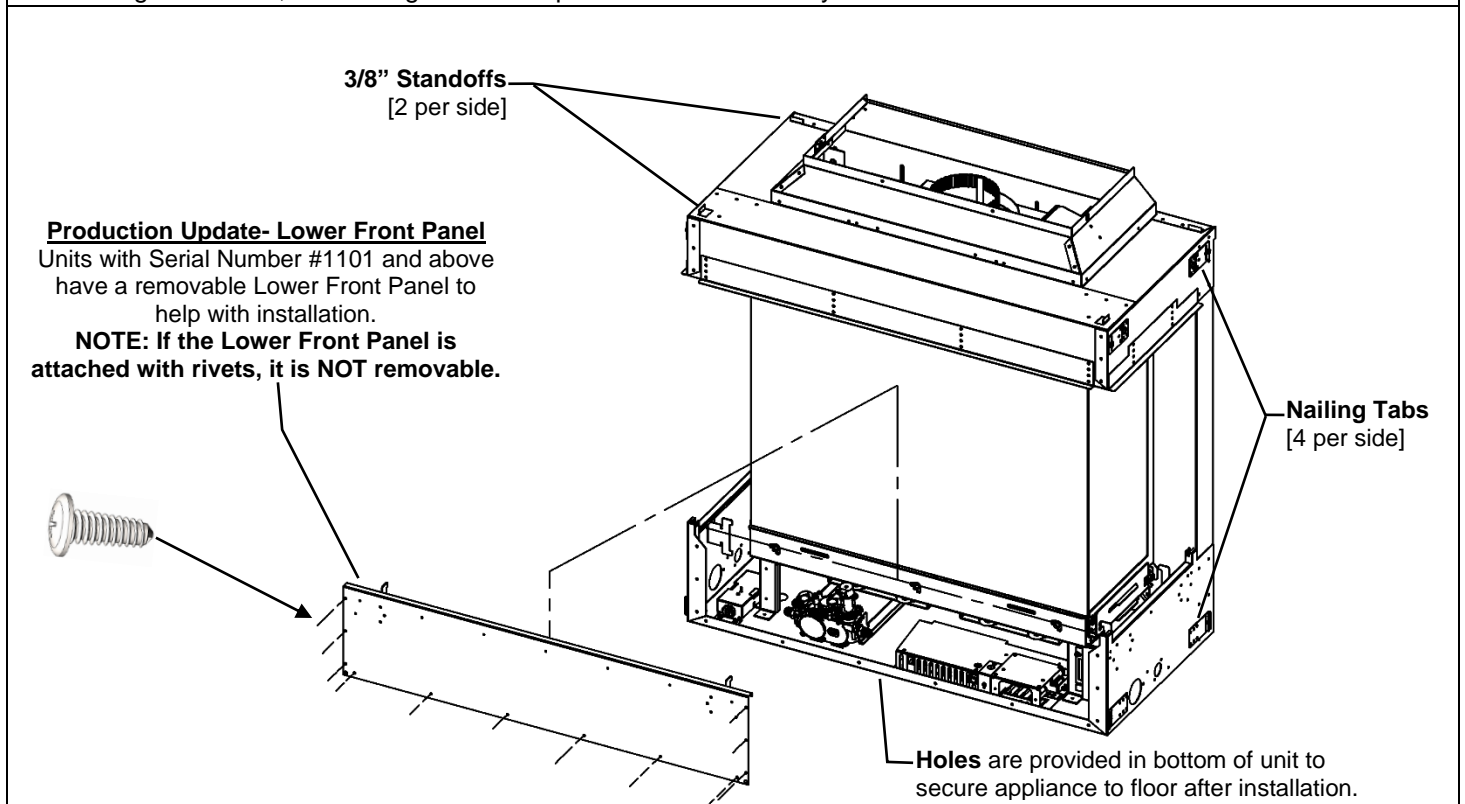

MQZCVBG34

-Nailing Tab Guide-

[Qty] 4 Nailing Tabs are located on each side of the front frame. These Nailing Tabs are used to attach the appliance to framing.

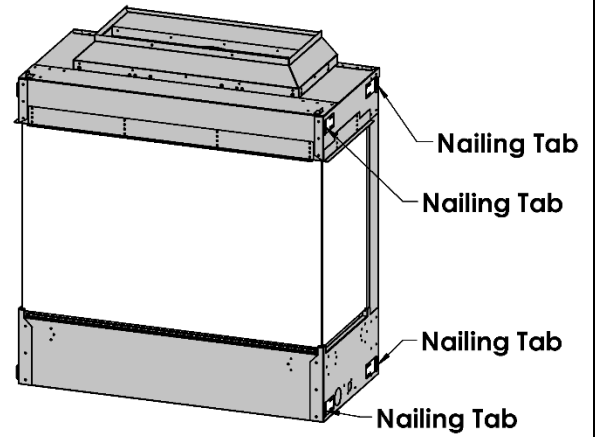
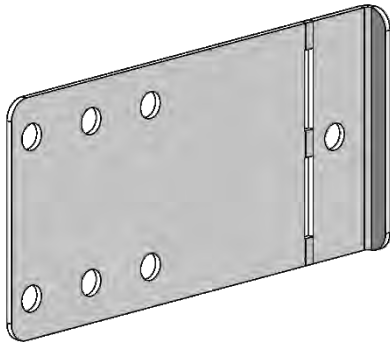

These Nailing Tabs can be used in several ways:

To attach to upper and lower framing:

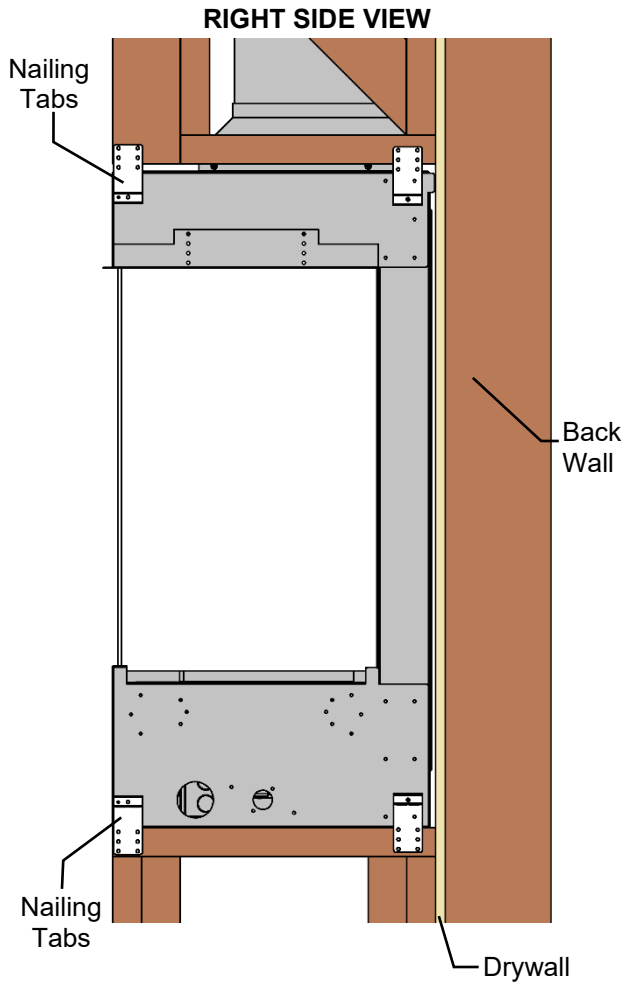

To attach to vertical studs with Corner Kit installed:

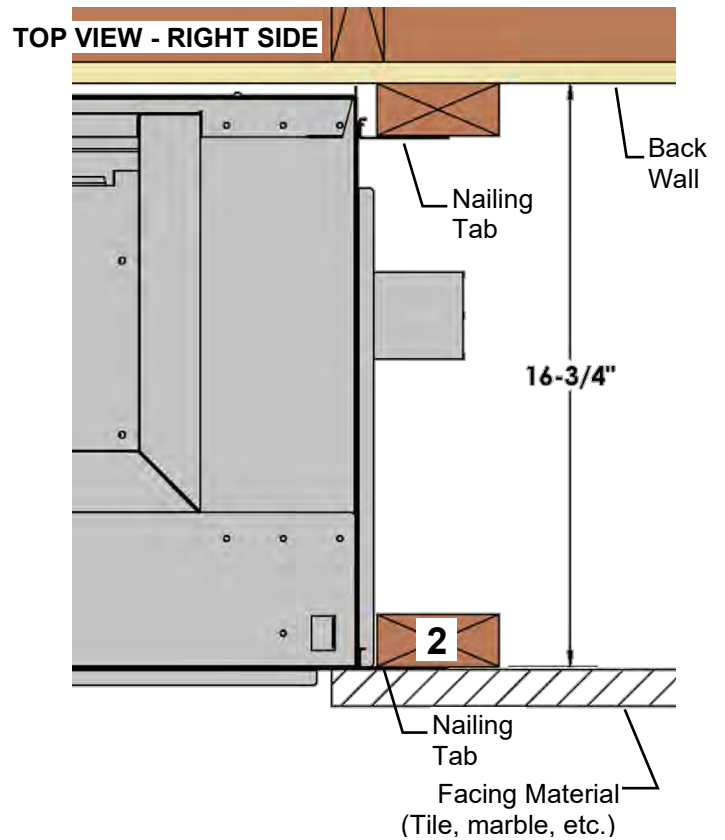

1
Pull up 90° for wall flush with fireplace face.

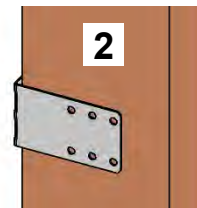

2
Rotate 180° for framing flush with fireplace face.

MQZCVBG34 Bay Peninsula

Locating Your Appliance

LOCATION KEY:

- A. Corner Kit- Left Side
- B. Flat on Wall
- C. Corner Kit- Right Side
- D. Corner Kit- Left Side
- E. Corner Kit- Right Side
- F. 45° Corner
- G. As an Island*

*Island installation with a top vent is possible as long as the horizontal portion of the vent system does not exceed 20 feet (6.1 m).

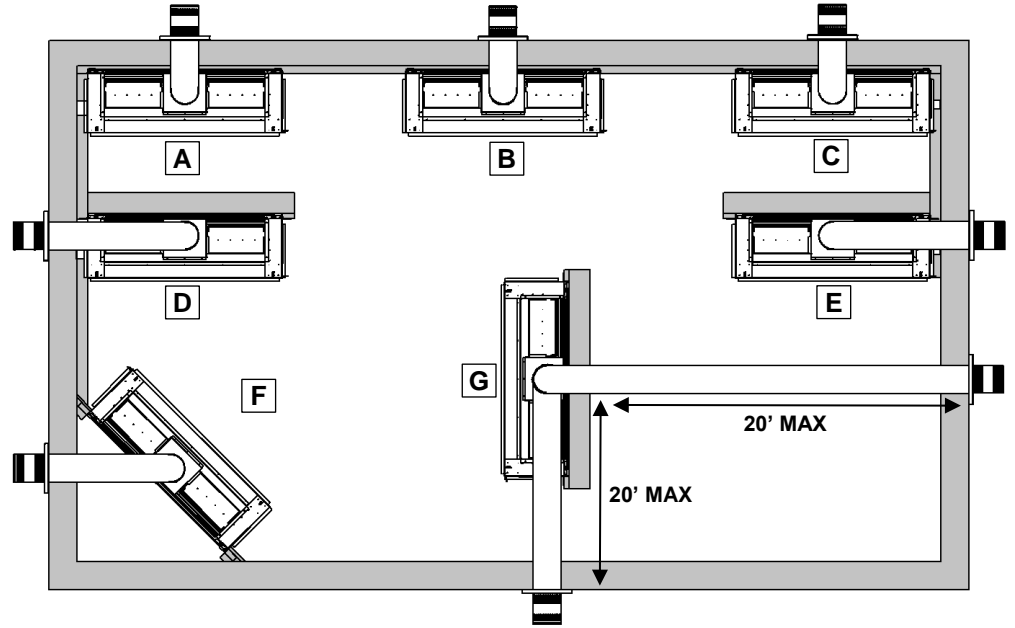

MQZCVBG34 Bay Peninsula

Fireplace Dimensions

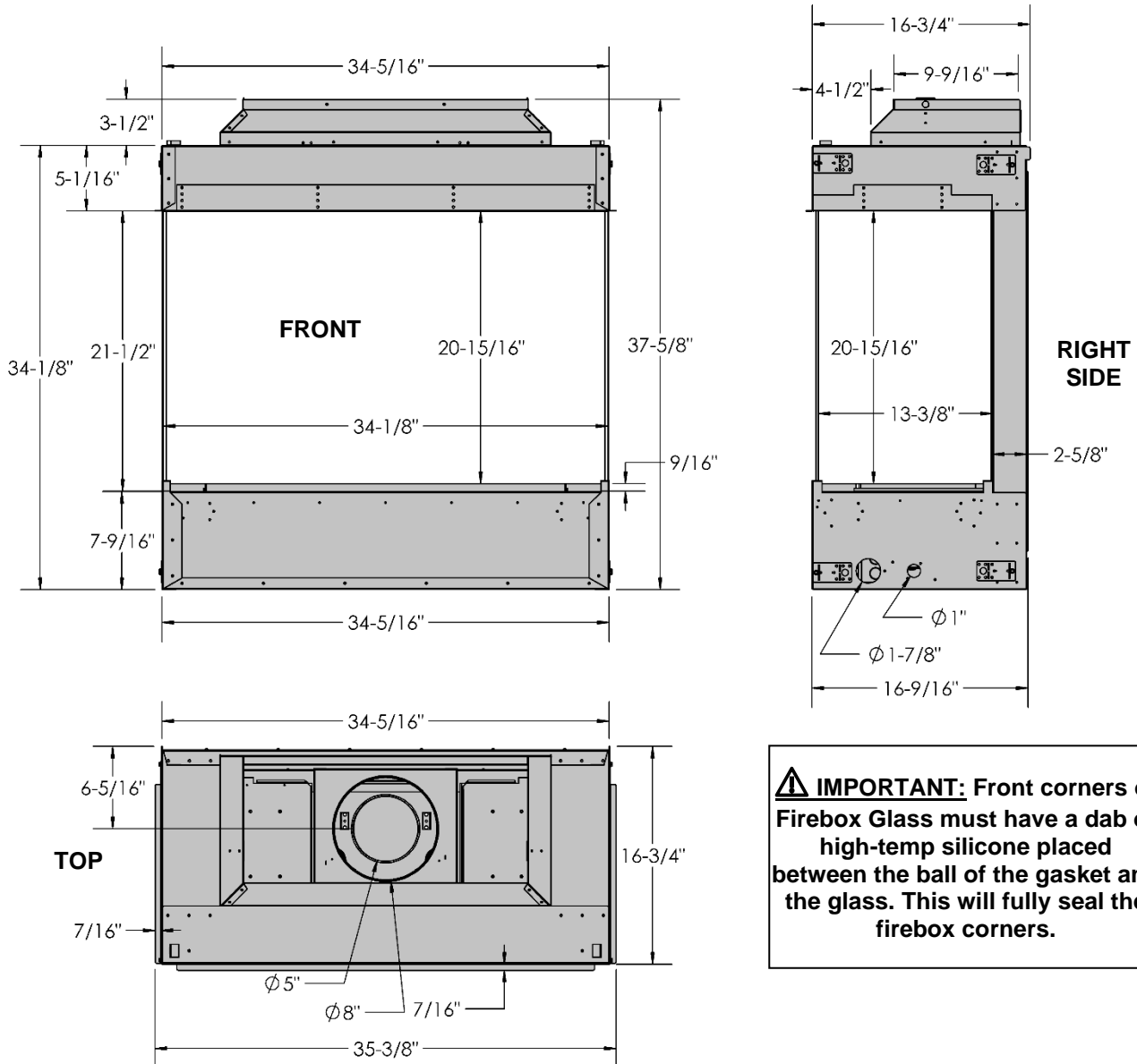

MQZCVBG34 -Vented Chase Requirements-

FIREPLACE CHASE MUST BE VENTED AT THE TOP OF THE ENCLOSURE.

- If you are using grills, you **MUST** use Kingsman Grills (V34EG or V34EGS).
- Minimum **2-1/4" Gap** at top of enclosure for 3-Sided Open Top chases, and a **3" Gap** for Corner Installations.

Chase Vent Openings **LARGER** than the required minimums **ARE** allowed and will reduce surface temperatures. Must be flush with top of enclosure.

HEAT CANNOT BE DISCHARGED INTO THE WALLS, FLOOR, OR CEILING. Heat must exit through the required vented chase opening near the ceiling.

ELECTRICAL WIRES IN CHASE MUST BE PROPERLY ATTACHED TO INSIDE WALL OF CHASE. Please follow the current CSA C22.1 Canadian Electrical Code or the National Electrical Code; ANSI/NFPA 70 when installed in the United States.

⚠ If using insulation in vented chase (i.e. for outside wall), wall board / drywall is required to support all insulation. Vented chase must be clean and free of all debris (i.e. loose insulation, pieces of wood, etc.)

Vented Chase Opening Options:

Full Chase Options:

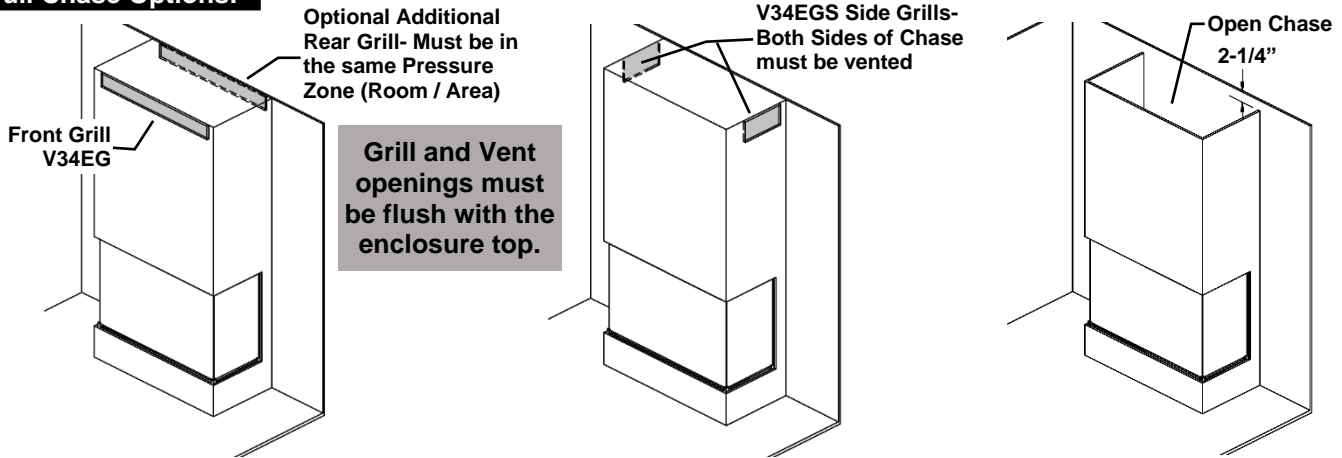

Recessed Chase Options:

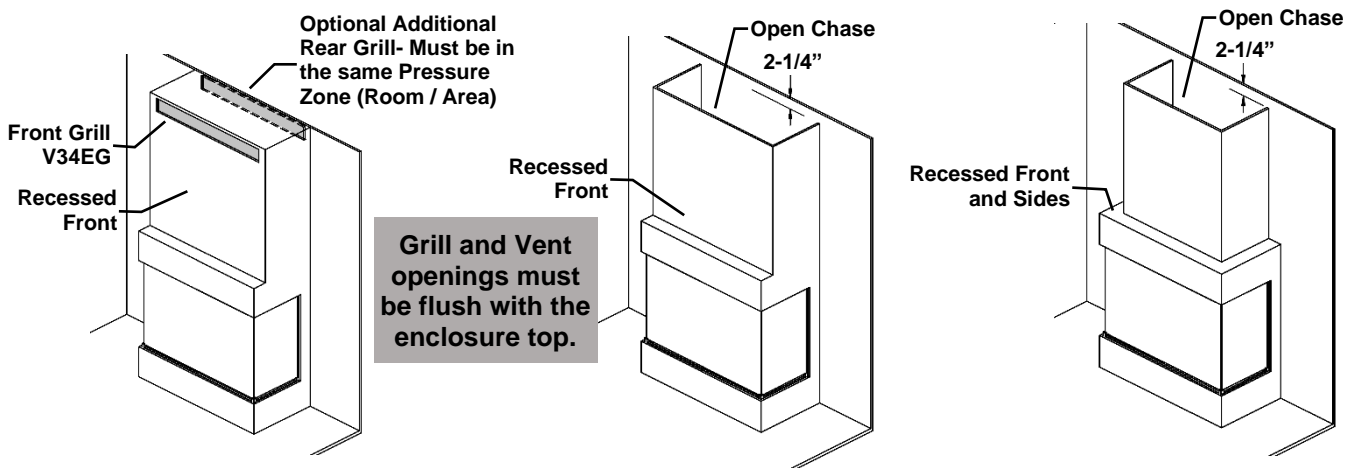

LH or RH Corner Chase Options (Corner Kit Required):

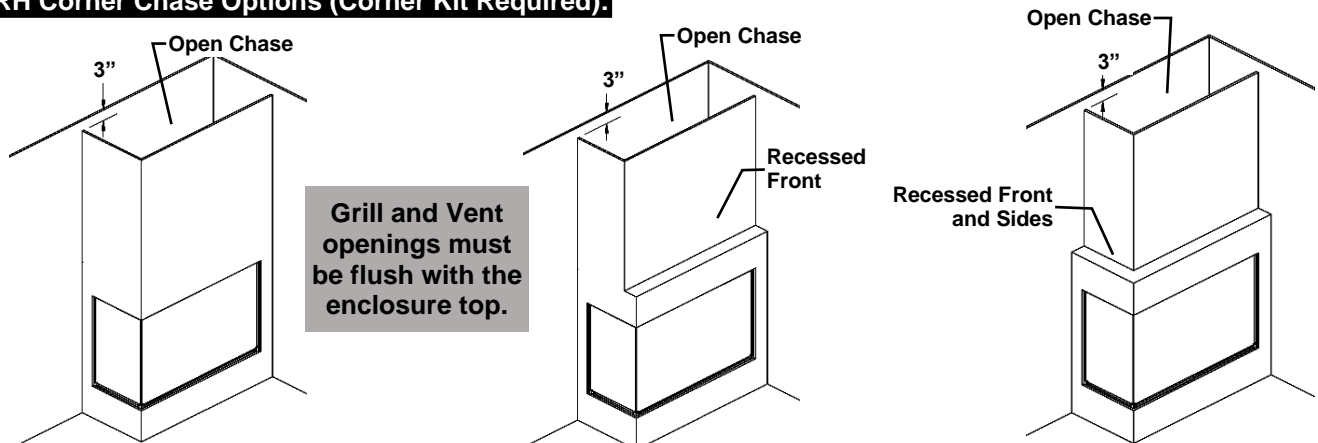

MQZCV34BG Framing Dimensions- Full Chase with Front -OR- Side Grills

Grills **MUST** be located at top of chase. **V34EG** Front Grill -OR- **V34EGS** Side Grills may be used. If **V34EGS** Side Grills are used, both sides of chase must be vented.

NOTE: These structures are not load bearing.

No loose Combustibles (wood, wiring, etc.) are allowed inside the open Chase area.

Unit and Framing can be covered with combustible materials.

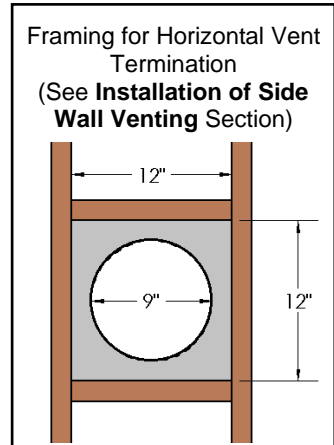
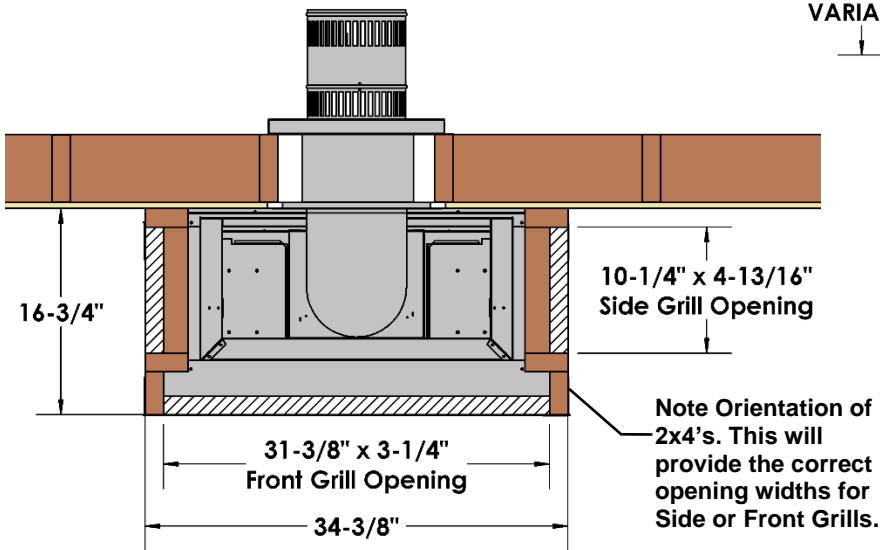
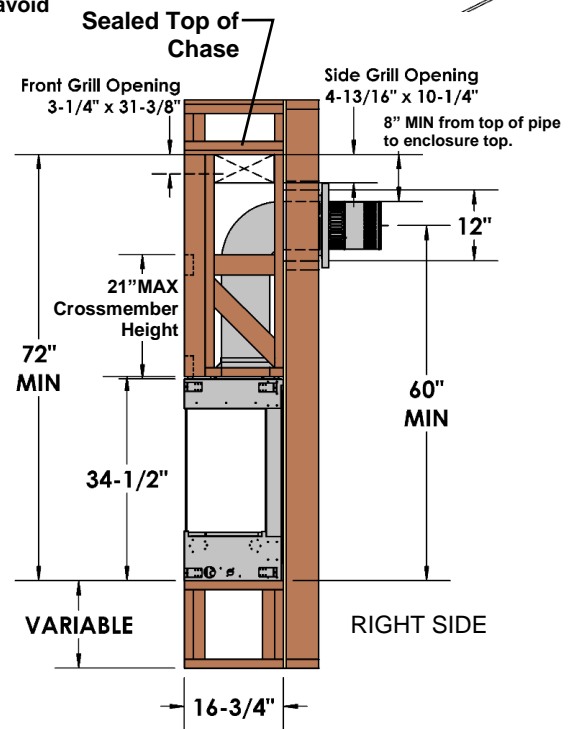
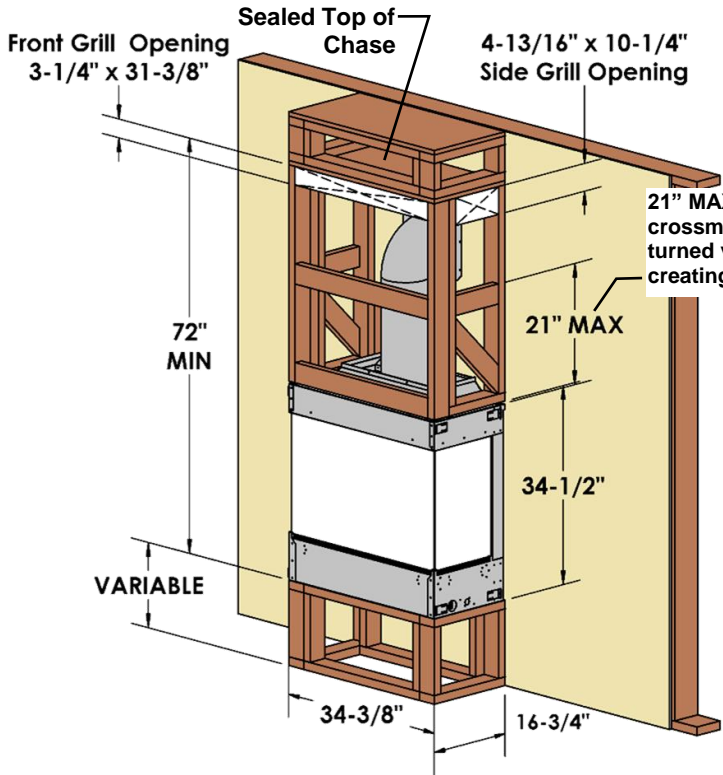
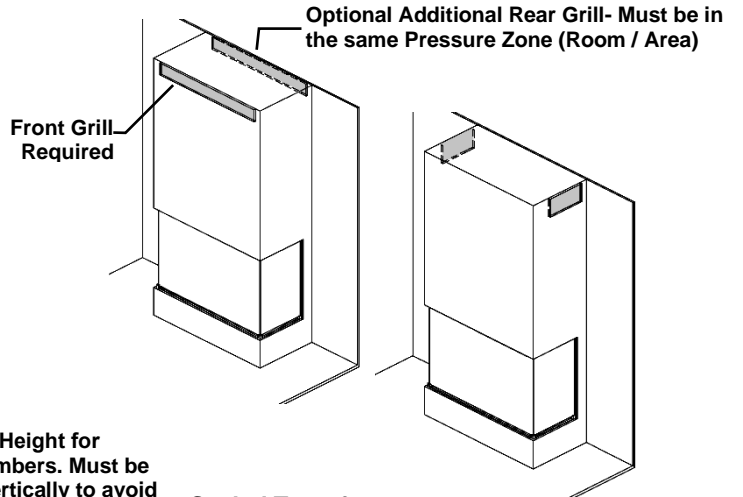

MQZCV34BG Framing Dimensions- Full Chase with Open Top

The top of the chase must have an opening of 2-1/4" on 3 sides.

NOTE: These structures are not load bearing.

No loose Combustibles (wood, wiring, etc.) are allowed inside the open Chase area.

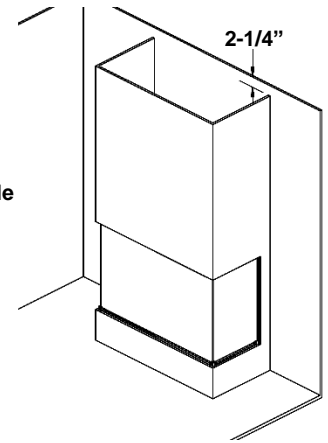

Unit and Framing can be covered with a combustible i.e., drywall.

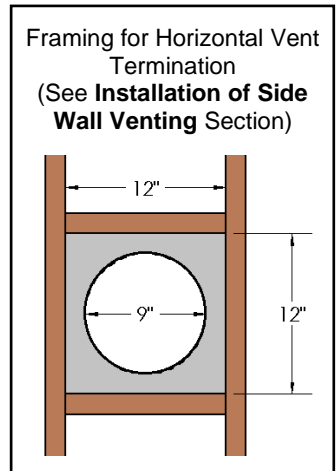
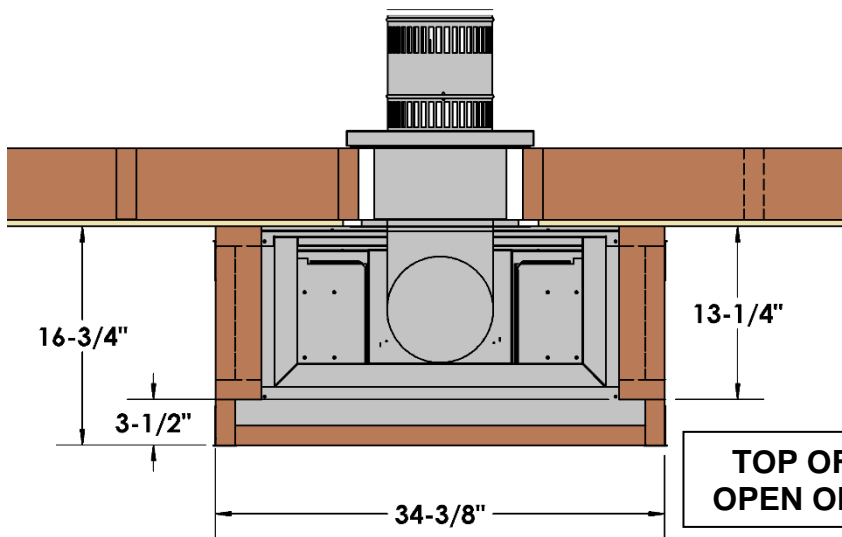
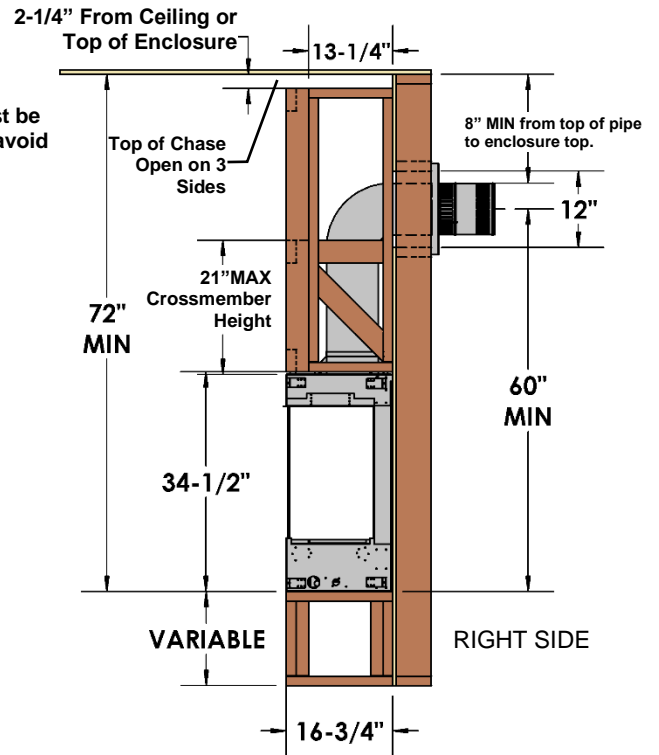
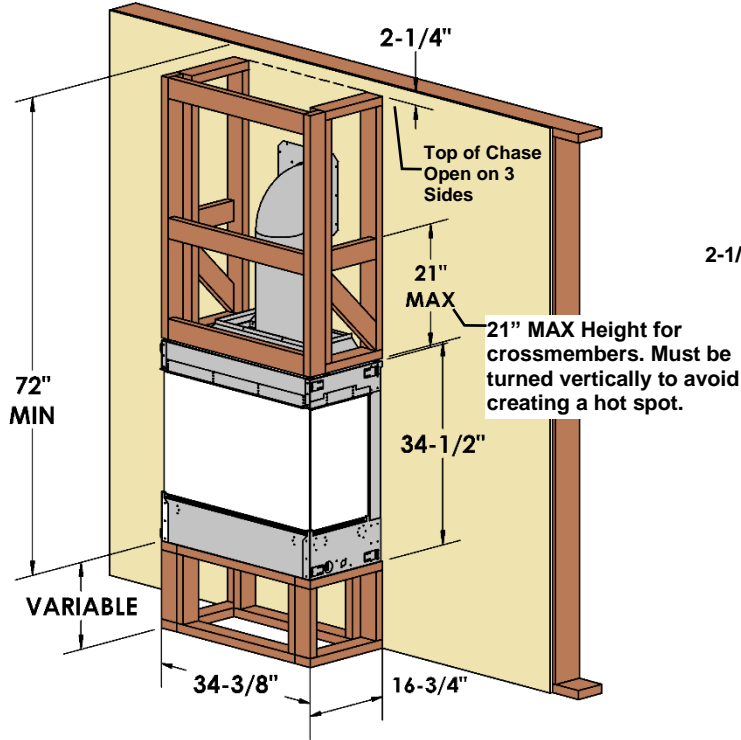

MQZCV34BG Framing Dimensions- Recessed Front Chase with Front Grill

Grill **MUST** be located at top of chase. **V34EG** Front Grill must be used. No Side Grill Option as Chase is too small.

NOTE: These structures are not load bearing.

No loose Combustibles (wood, wiring, etc.) are allowed inside the open Chase area.

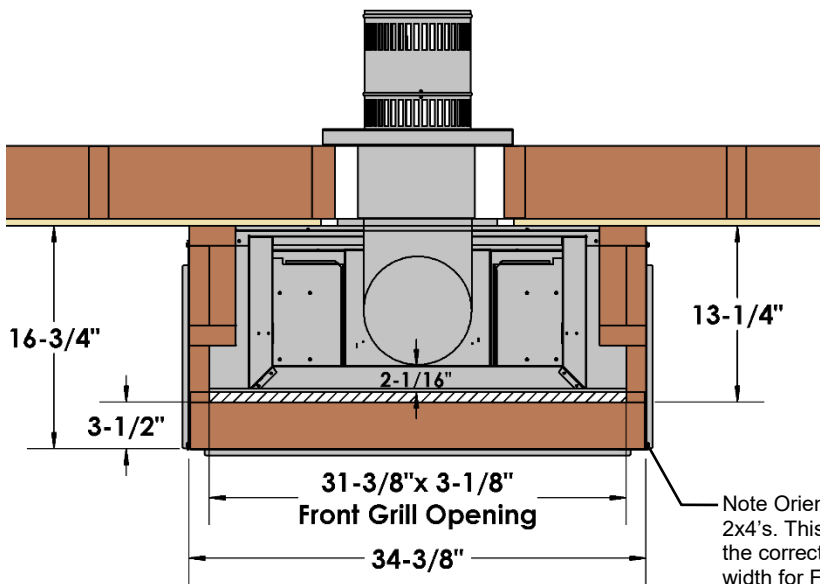
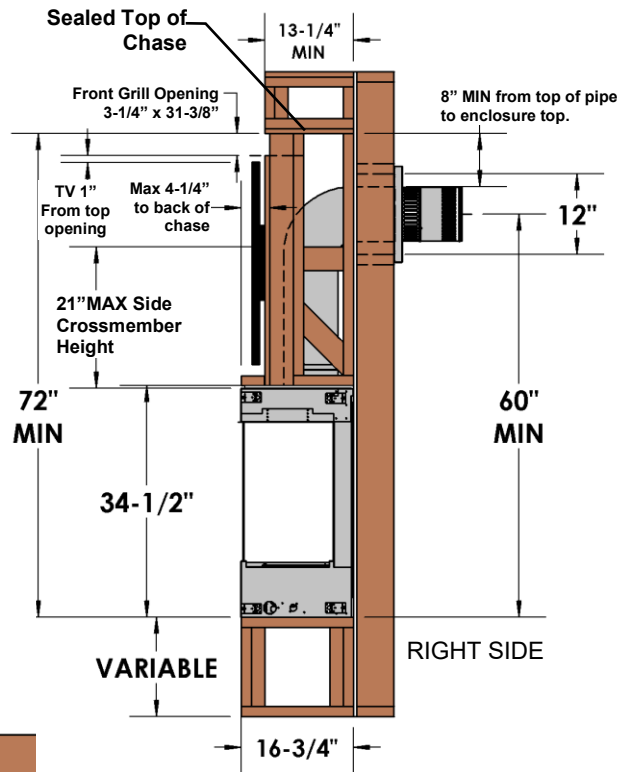
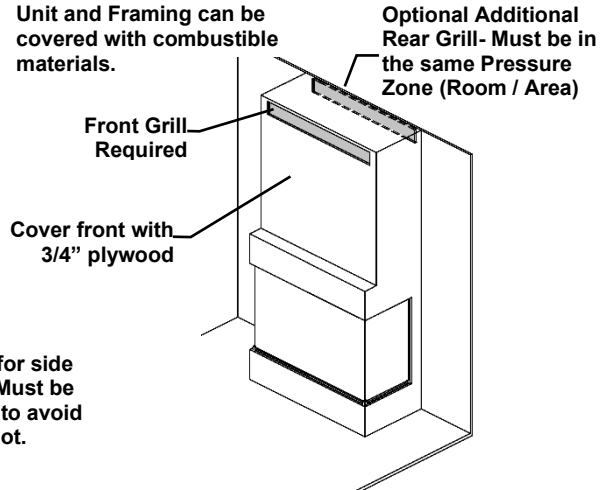
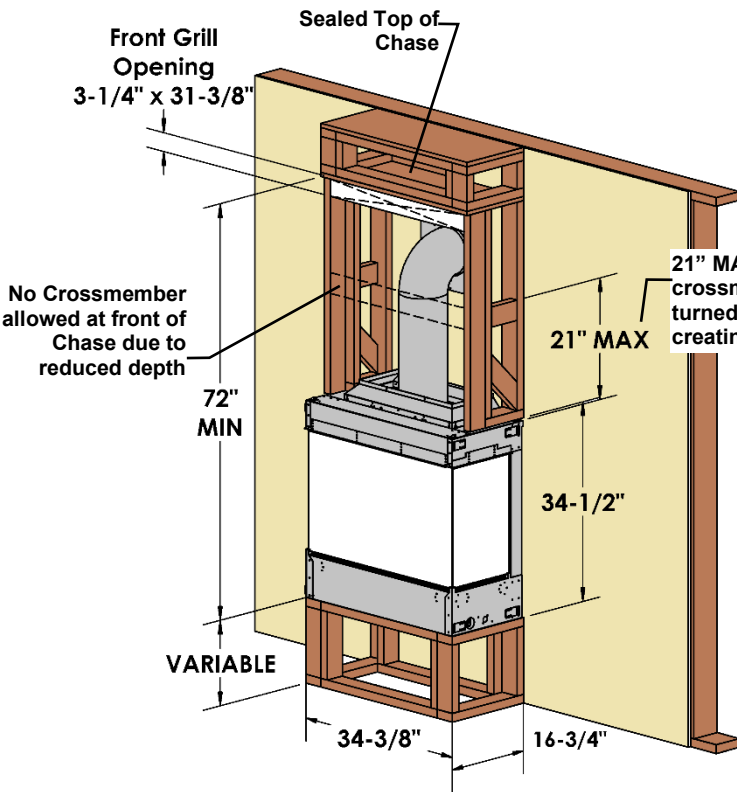

Note Orientation of 2x4's. This will provide the correct opening width for Front Grill.

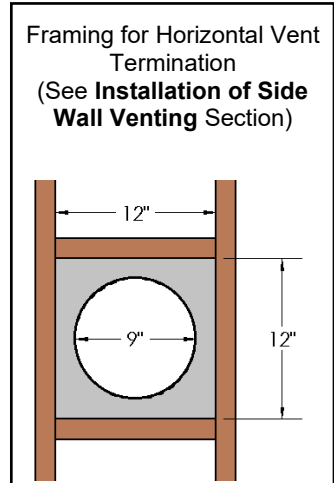

MQZCV34BG Framing Dimensions- Recessed Front Chase with Open Top

The top of the chase must have an opening of 2-1/4" on 3 sides.

NOTE: These structures are not load bearing.

No loose Combustibles (wood, wiring, etc.) are allowed inside the open Chase area.

Unit and Framing can be covered with combustible materials.

Cover front of chase with 3/4" plywood

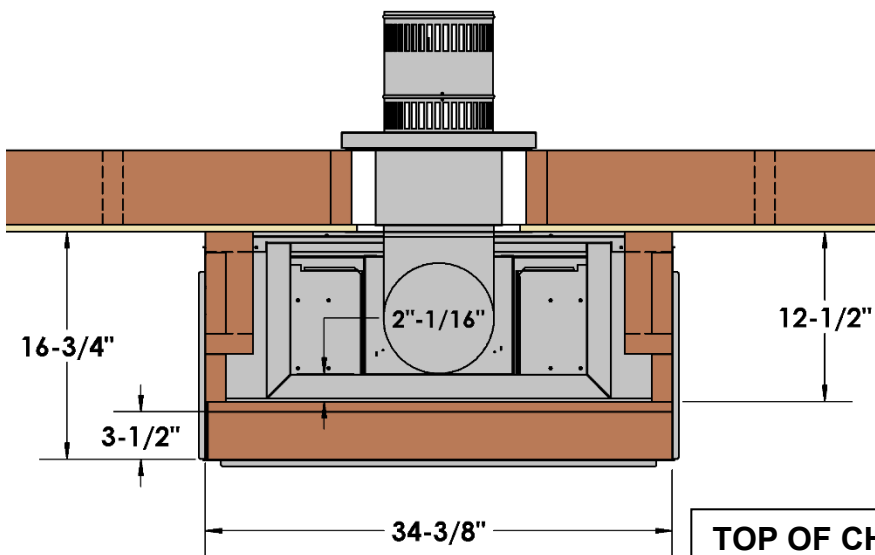
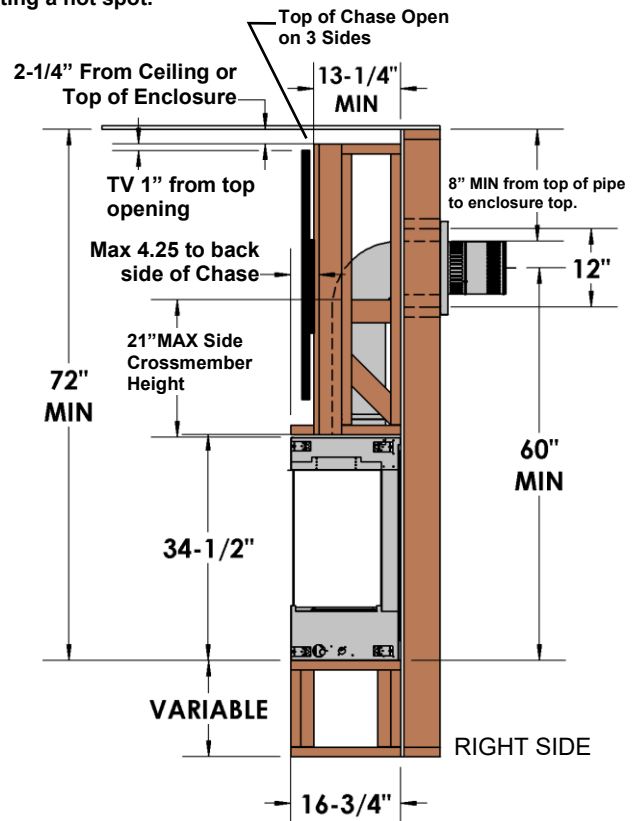
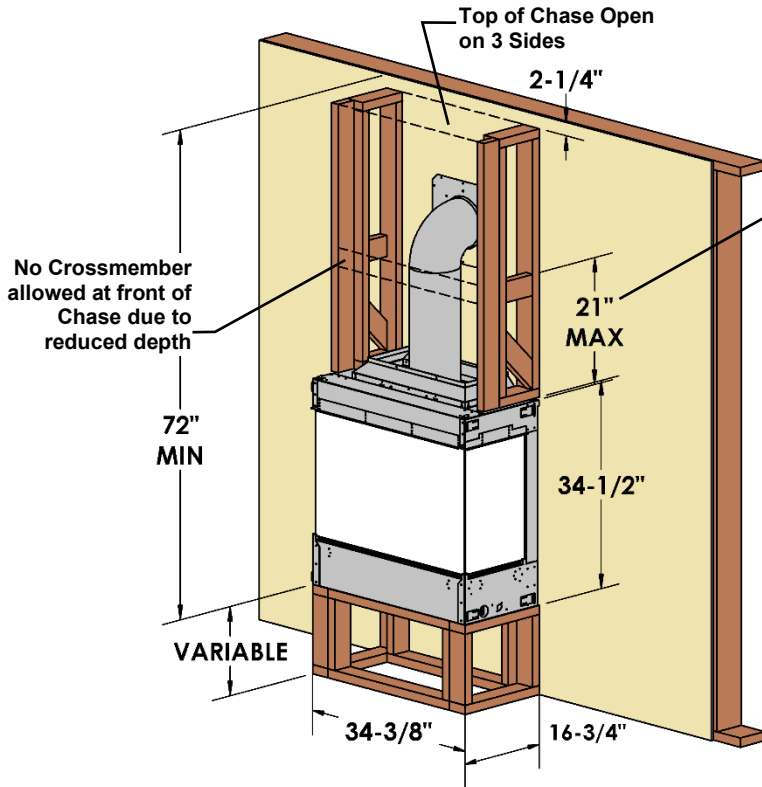
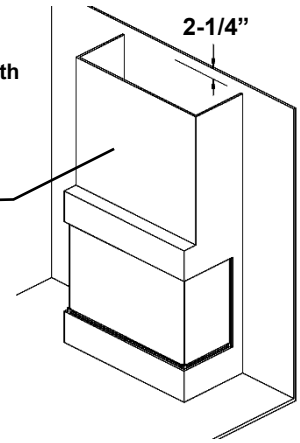

TOP OF CHASE OPEN ON 3 SIDES

Framing for Horizontal Vent Termination
(See Installation of Side Wall Venting Section)

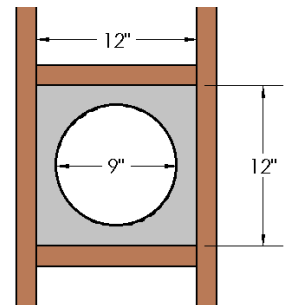

MQZCV34BG Framing Dimensions- Recessed Front and Side Chase Open Top

The top of the chase must have an opening of 2-1/4" on 3 sides.

Do not use combustible materials (i.e., wood framing) inside of Enclosure.

Use metal mount brackets as shown below to secure the enclosure.

NOTE: These structures are not load bearing.

No loose Combustibles (wood, wiring, etc.) are allowed inside the open Chase area.

Use 3/4" plywood and metal mount brackets. No combustibles are allowed inside the recessed chase.

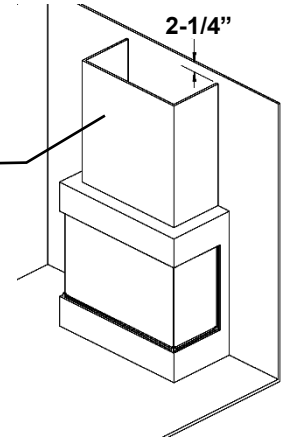

Use 3/4" plywood and metal mount brackets. No combustibles are allowed inside the recessed chase.

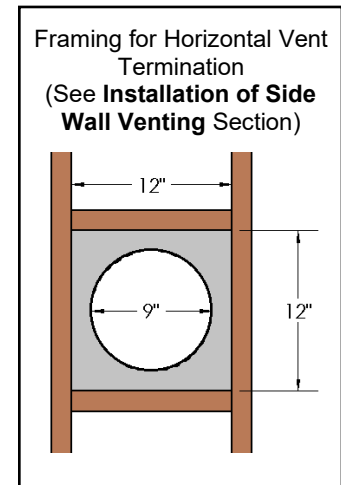
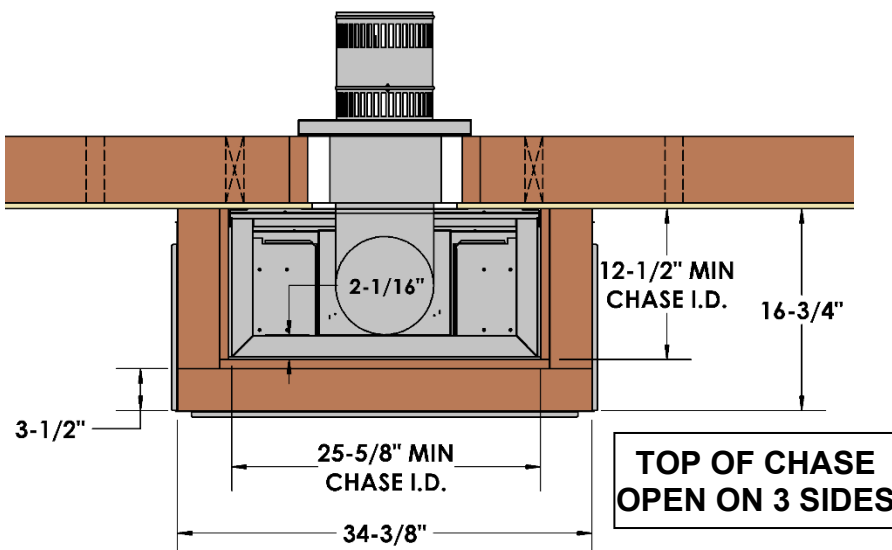
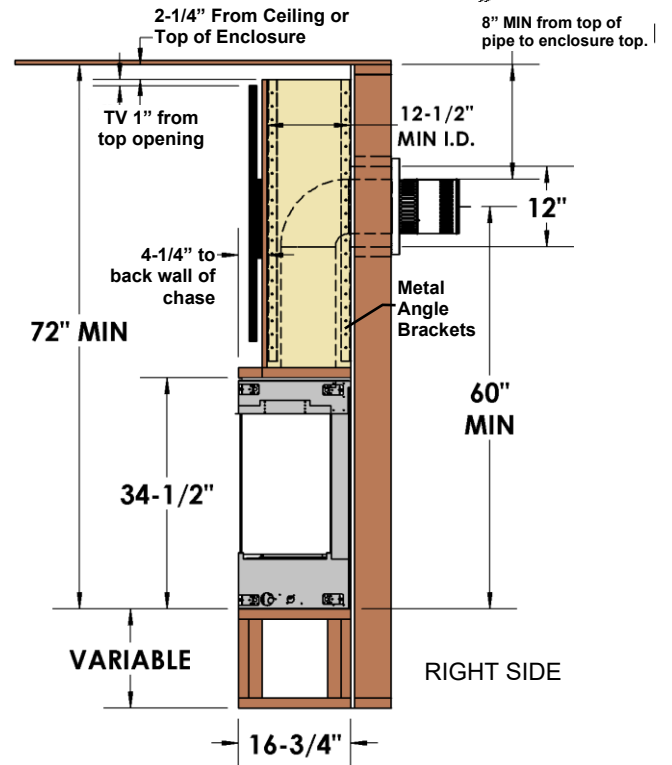
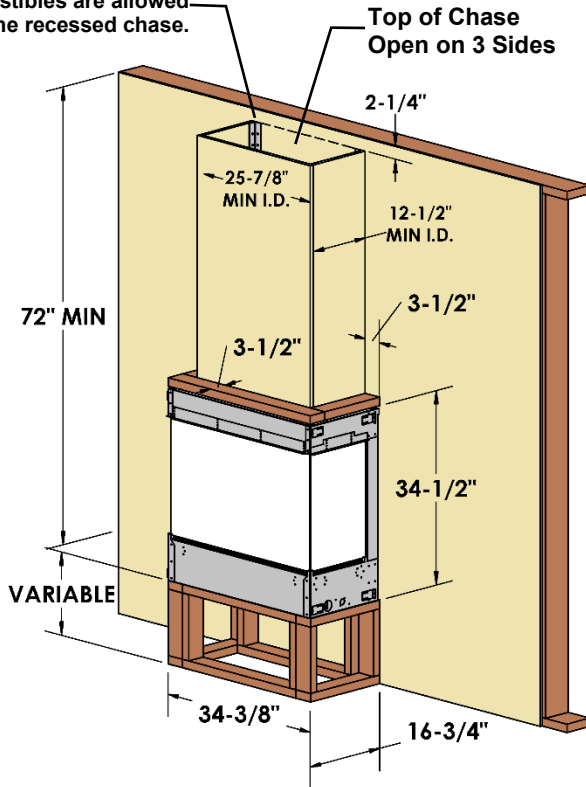

MQZCV34BG Corner Framing Dimensions- Full Chase with Open Top

ZCV34BGCK Corner Kit Required. Can be used on left or right side of unit.
The top of the chase must have an opening of 3".

NOTE: These structures are not load bearing.

No loose Combustibles (wood, wiring, etc.) are allowed inside the open Chase area.

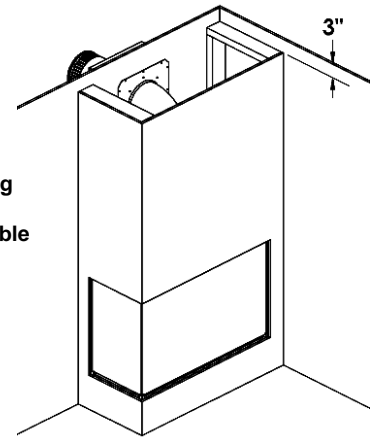

Unit and Framing can be covered with a combustible i.e., drywall.

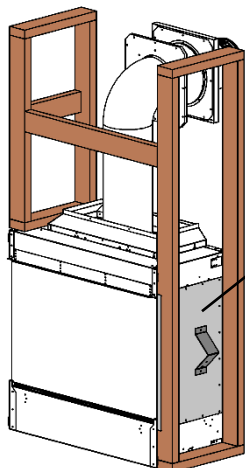
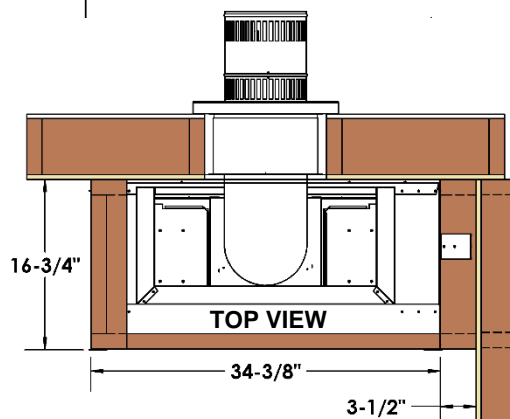
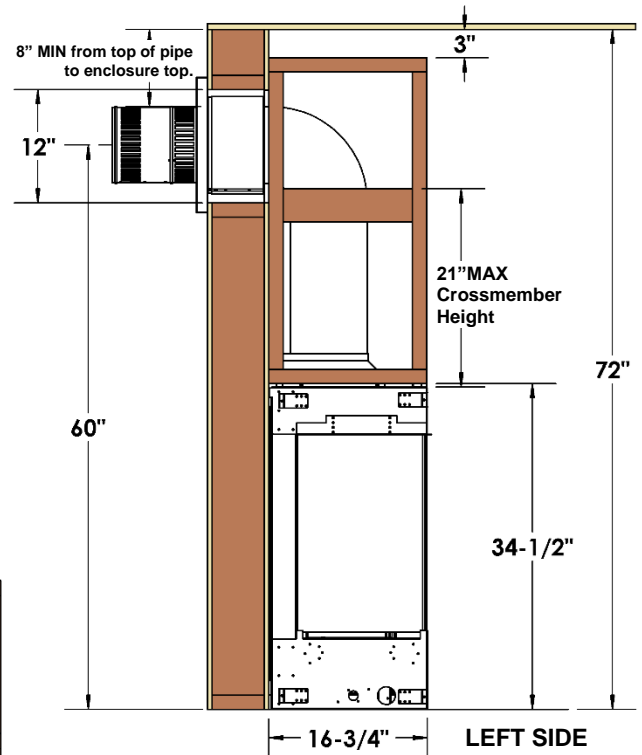
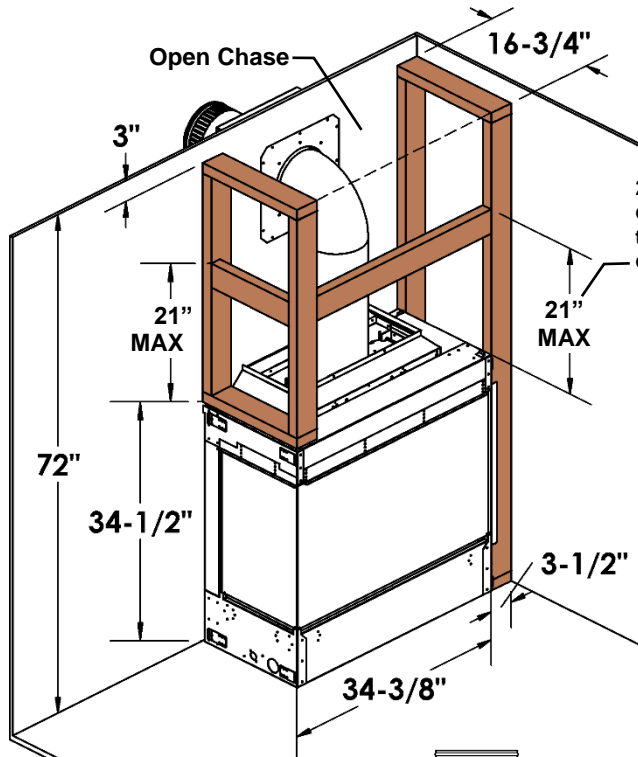

Cavity between 2 x 4 studs must be clear of combustibles.

Framing for Horizontal Vent Termination
(See Installation of Side Wall Venting Section)

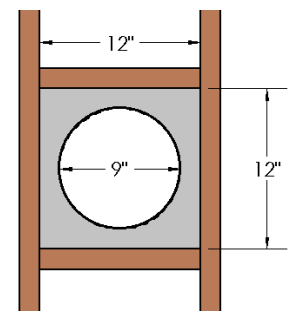

MQZCV34BG Corner Framing Dimensions -Recessed Front Chase- Open Top

ZCV34BGCK Corner Kit Required. Can be used on left or right side of unit.
The top of the chase must have an opening of 3".

NOTE: These structures are not load bearing.

No loose Combustibles (wood, wiring, etc.) are allowed inside the open Chase area.

Unit and Framing can be covered with combustible materials.

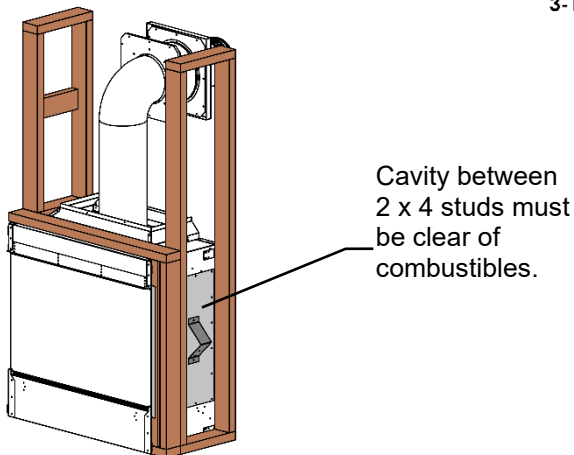
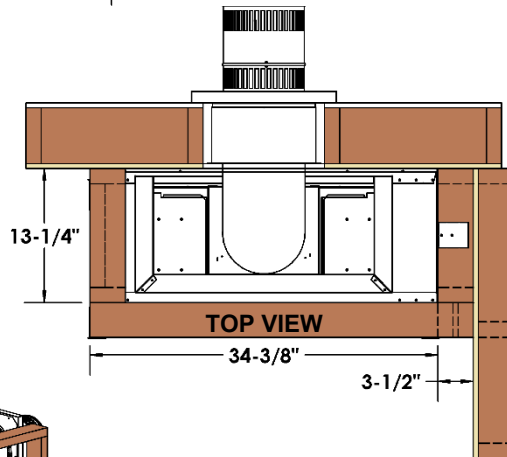
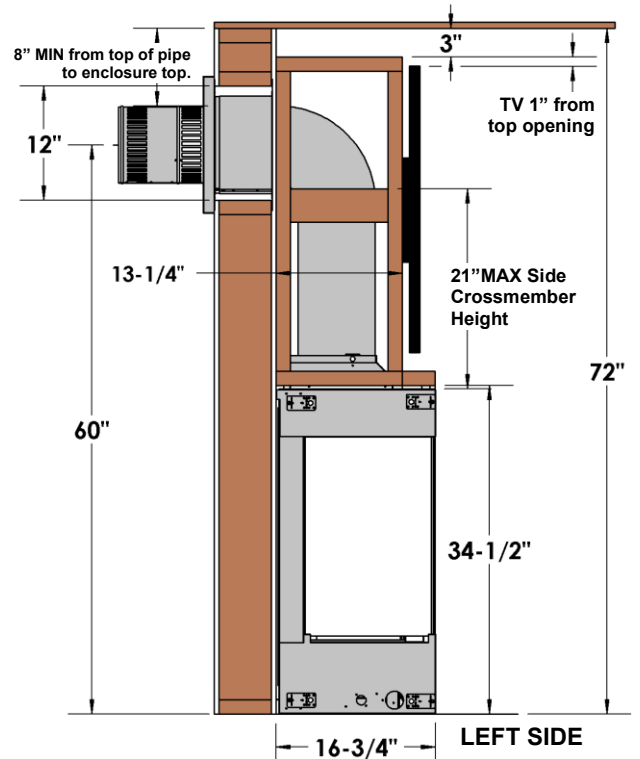
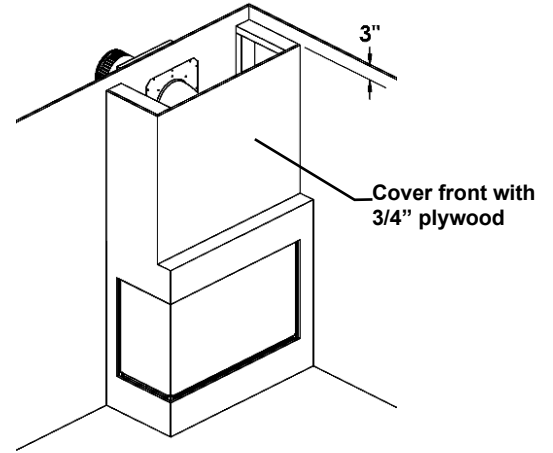
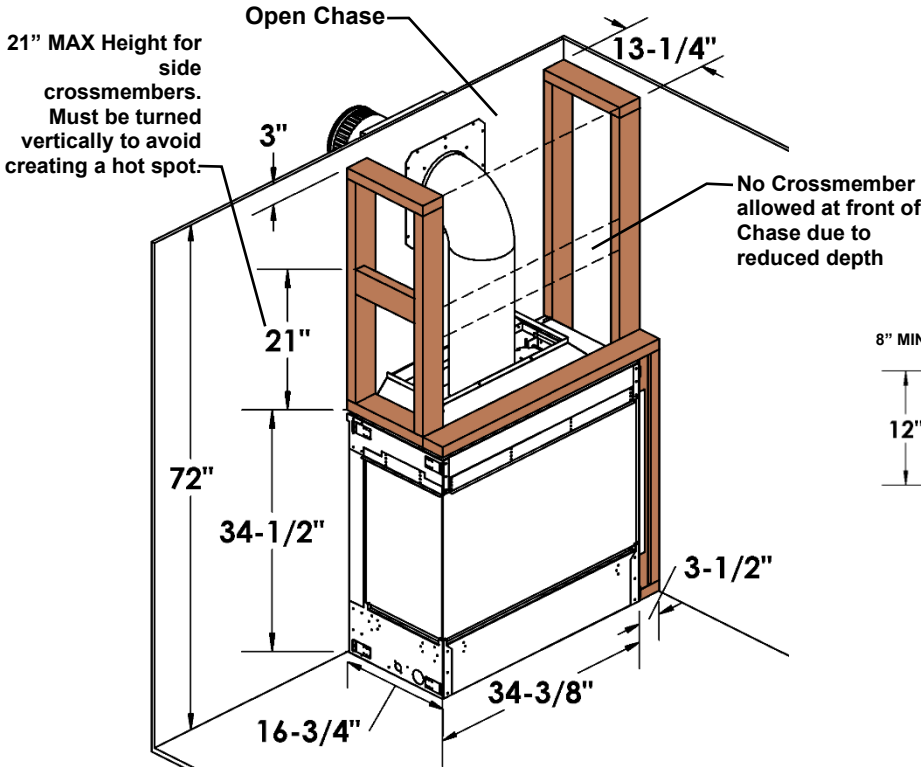

Framing for Horizontal Vent Termination
(See Installation of Side Wall Venting Section)

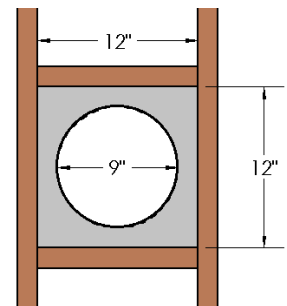

MQZCV34BG Corner Framing Dimensions- Recessed Front and Side Chase- Open Top -

ZCV34BGCK Corner Kit Required. Can be used on left or right side of unit.

The top of the chase must have an opening of 3".

Do not use combustible materials (i.e., wood framing) inside of Enclosure.

Use metal mount brackets as shown below to secure the enclosure.

NOTE: These structures are not load bearing.

No loose Combustibles (wood, wiring, etc.) are allowed inside the open Chase area.

Use 3/4" plywood and metal mount brackets. No combustibles are allowed inside the recessed chase.

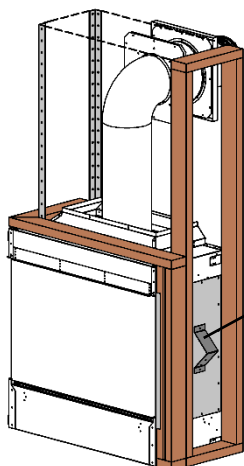
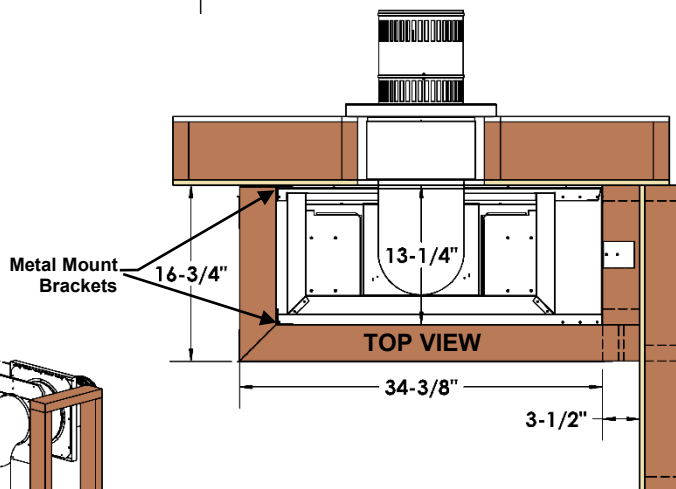
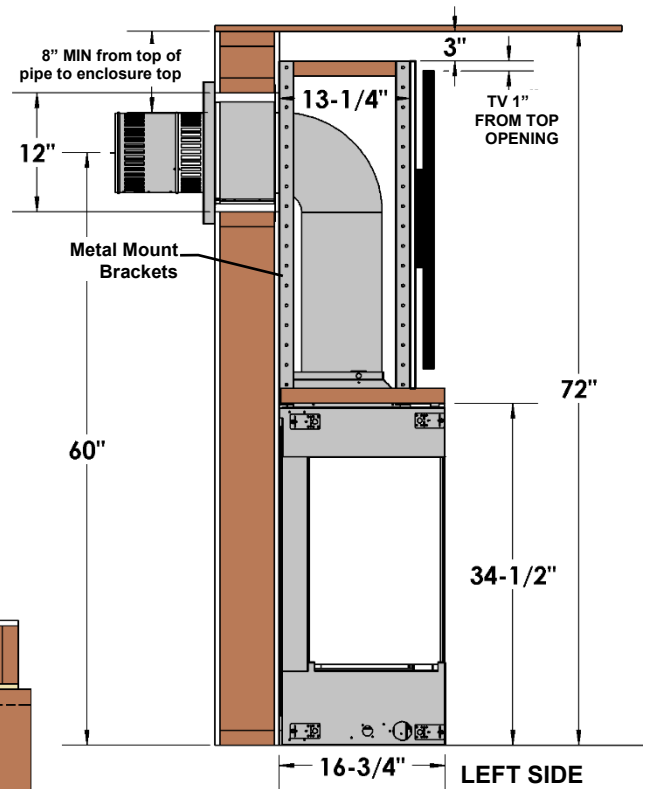
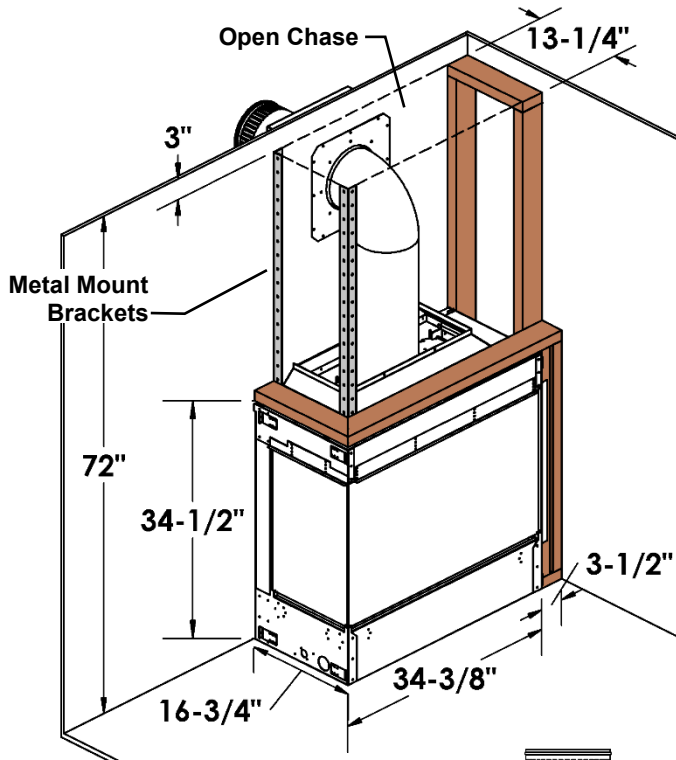
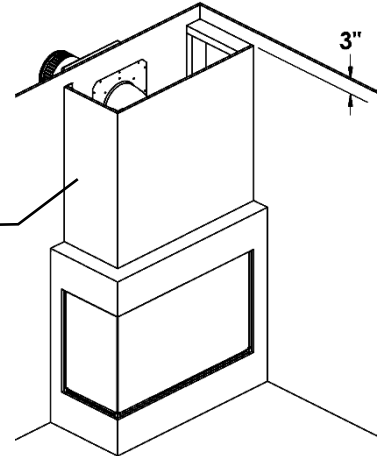

Cavity between 2 x 4 studs must be clear of combustibles.

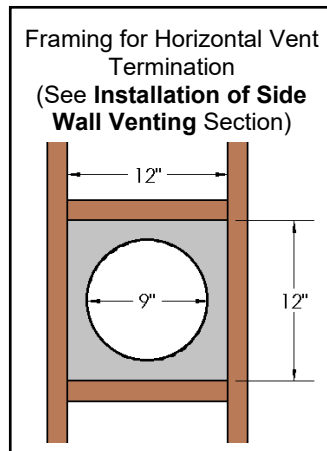

MQZCVBG34 -Mantel and Adjacent Wall Clearances

A **Combustible Mantel** can be placed immediately above the fireplace opening.

A **Combustible Hearth** can be placed immediately below the fireplace opening.

An **Adjacent Side Wall** may project directly from the side of the fireplace opening.

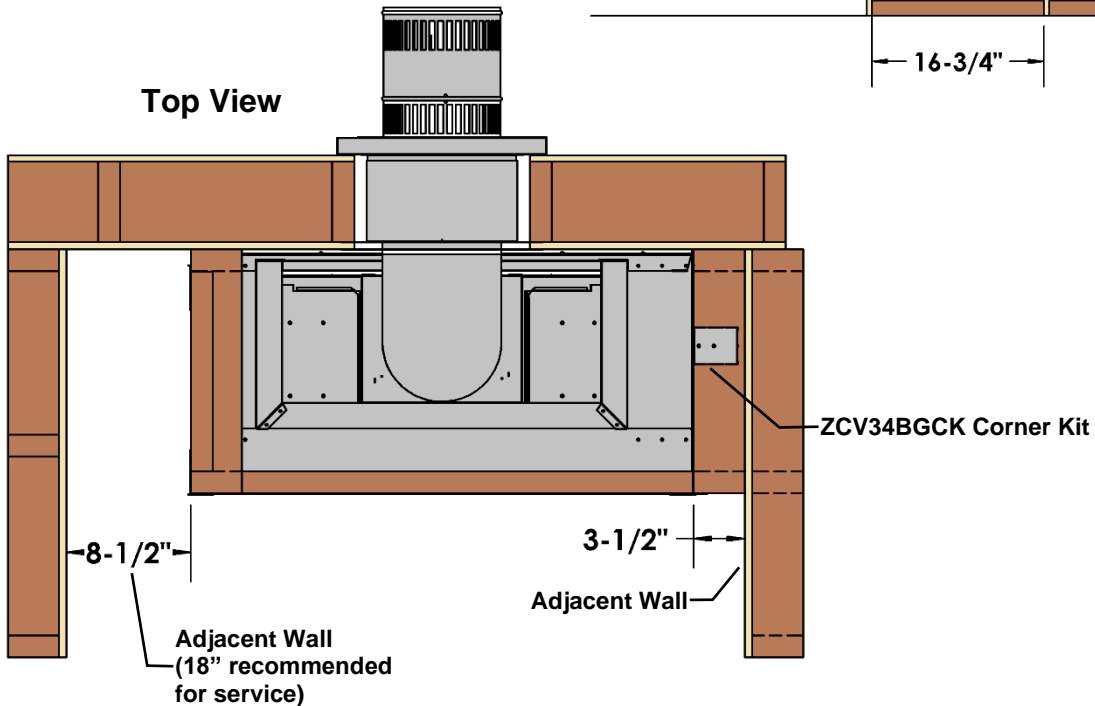
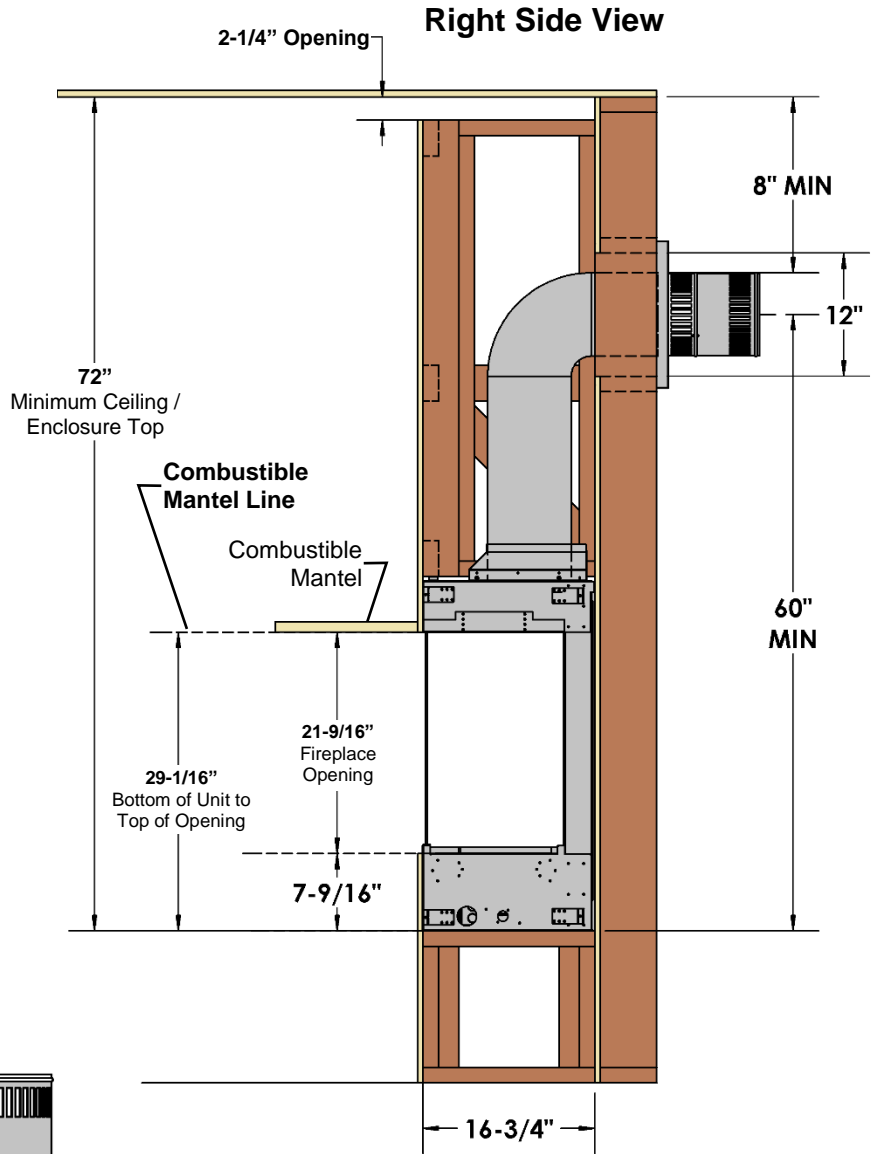

| | |
|---|-----------------|
| Front (Furniture, etc. from glass) | 36" [92cm] |
| Side (Furniture, etc. from glass) | 8-1/2" [21.6cm] |
| Side (from Stand-offs of Unit or Corner Kit) | 0" [0cm] |
| Back (from Stand-offs) | 0" [0cm] |
| Floor* | 0" [0cm] |
| Minimum Ceiling Height (from bottom of fireplace) | 72" [183cm] |
| Top (from Stand-offs) | 0" [0cm] |
| Top of 90° Bend in minimum Enclosure of 72" | 8" [20.3cm] |
| Top of 90° Bend in Enclosure over 72" | 8" [20.3cm] |

VENTING SYSTEMS

| | |
|---|---------------------------------|
| Top of Horizontal Pipe | 1/1/2" [3.8cm] |
| Side & Bottom of Horizontal Pipe | 1" [2.5cm] All Vent Systems |
| Vertical Vent Pipe in Enclosure under 72" | 2-7/8" [7.3cm] All Vent Systems |
| Vertical Vent Pipe in Enclosure over 76" | 1" [2.5cm] All Vent Systems |
| Wall Thimble or Attic Insulation Shield (outside of barrel) | 0" [0cm] |

A TV may be mounted above the fireplace. Must have 1" clearance from the top opening.

No combustibles (crossmembers, etc.) are allowed inside a recessed chase with minimum dimensions of 25-5/8" wide by 12-1/2" deep.

⚠ NOTE
 If using insulation in vented chase (i.e. for outside wall), wall board / drywall is required to support all insulation.
 Vented chase must be clean and free of all debris (i.e. loose insulation, pieces of wood, etc.).

*Note: If appliance is installed directly on carpeting or other combustible material other than wood flooring, a metal or wood panel extending the full width and depth of the appliance must be used. Carpet may extend 1 inch above the floor of the appliance.

Top of Enclosure must be sealed so that no heat can escape.

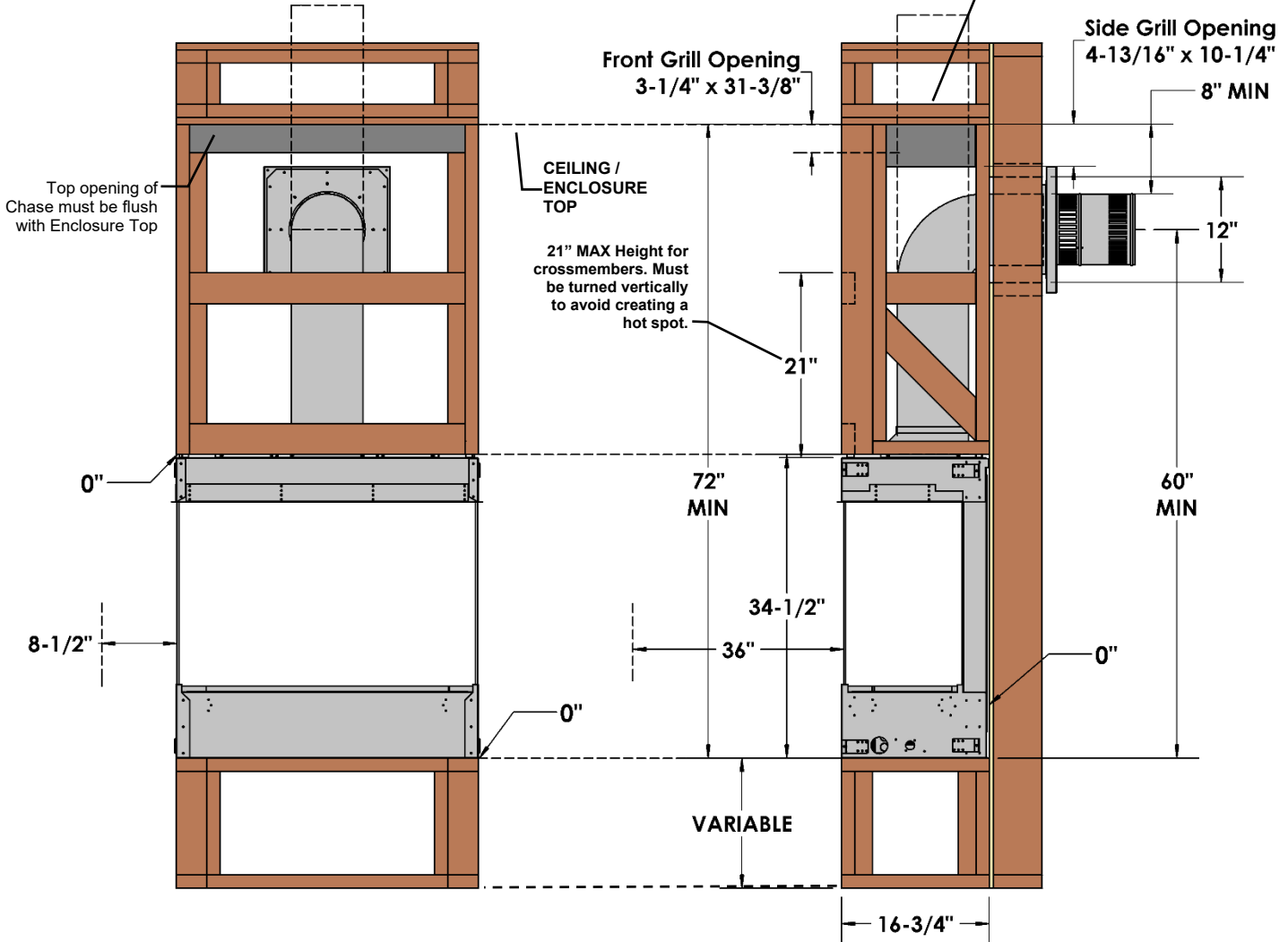

V34EG Grill Installation for MQZCVBG34

-Option-

⚠ Grill openings must be flush with the enclosure top. This is to prevent excess heat from becoming trapped in the top of the chase. Minimum 72" Chase Required. See Framing section of manual.

Parts List:

[1] Louver Grill (ready to paint)

This Grill Meets Minimum Opening Air Free Requirements.

Required Opening Dimensions: 31-3/8" wide x 3-1/4" tall x 1-3/4" deep.

Outer Trim Dimensions: 32-5/16" wide x 4-3/8" tall.

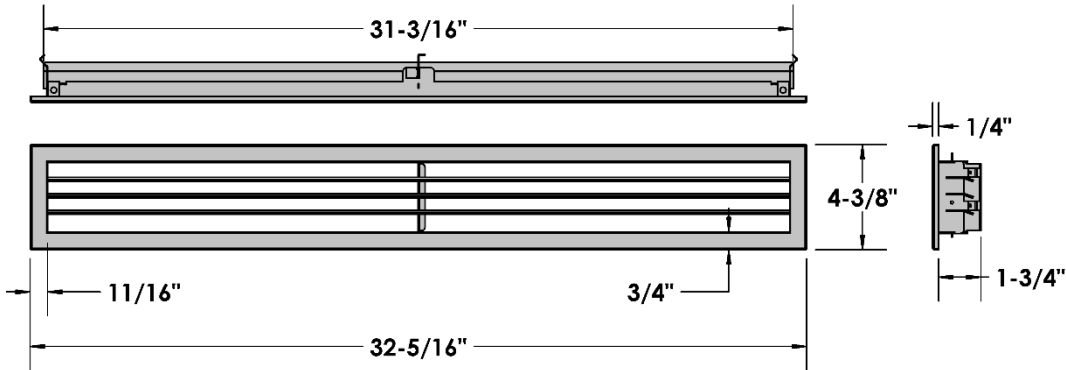

Installation: Insert Grill into opening and fasten to framing with a wood screw at each end.

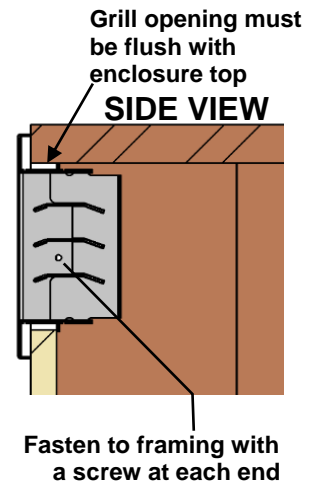
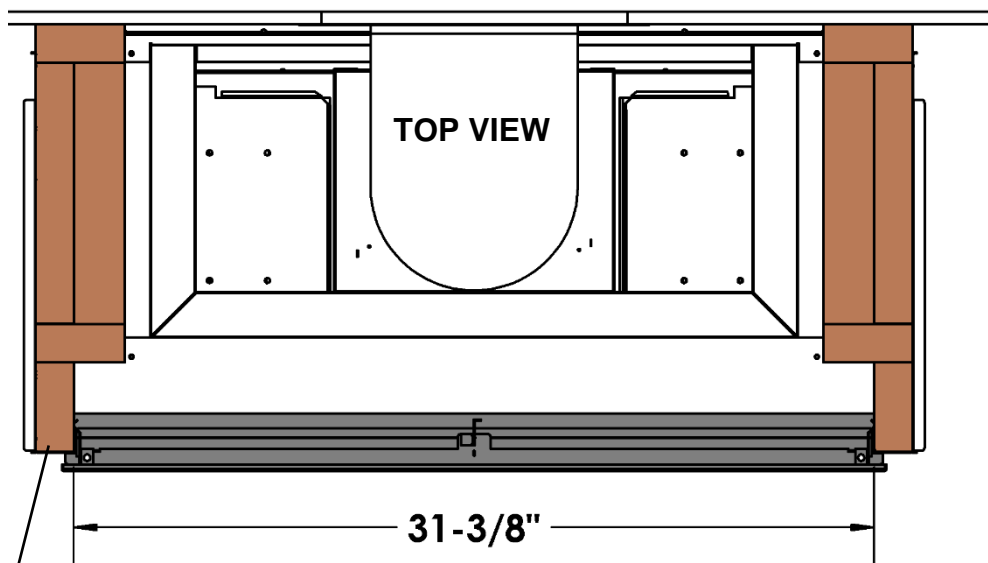

Note Orientation of 2x4's. This will provide the correct opening widths for Side or Front Grills.

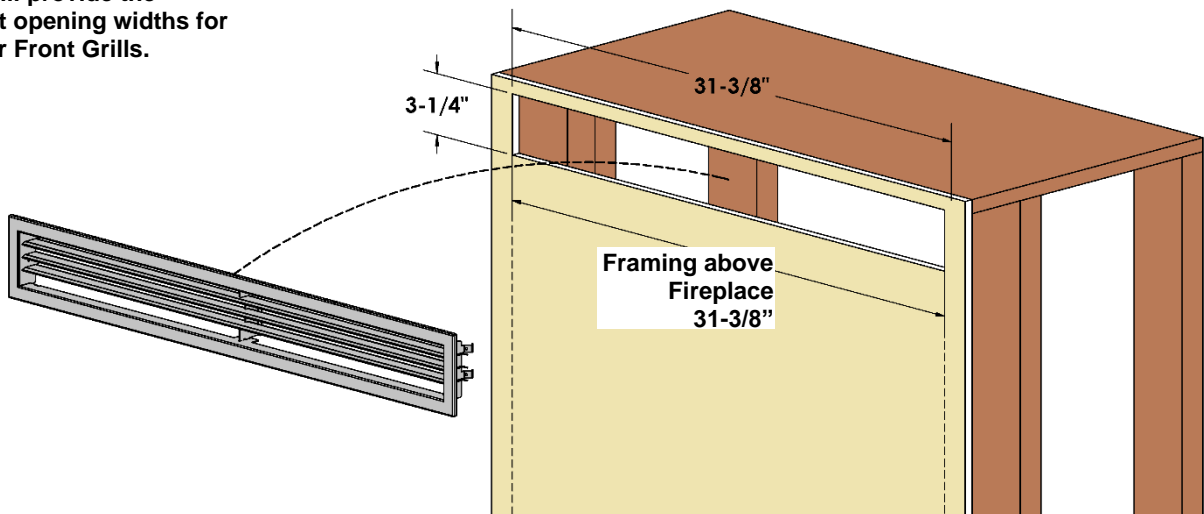

V34EGS Side Grill Installation for MQZCVBG34

-Option-

⚠ Grill openings must be flush with the enclosure top. This is to prevent excess heat from becoming trapped in the top of the chase. Minimum 72" Chase Required. See Framing section of manual.

Parts List:

[Qty 2] Side Grill assemblies (ready to paint)

Grills must be installed on both sides of chase.

Required Opening Dimensions: 10-1/4" wide x 4-13/16" tall

Outer Trim Dimensions: 11-1/4" wide x 6" tall

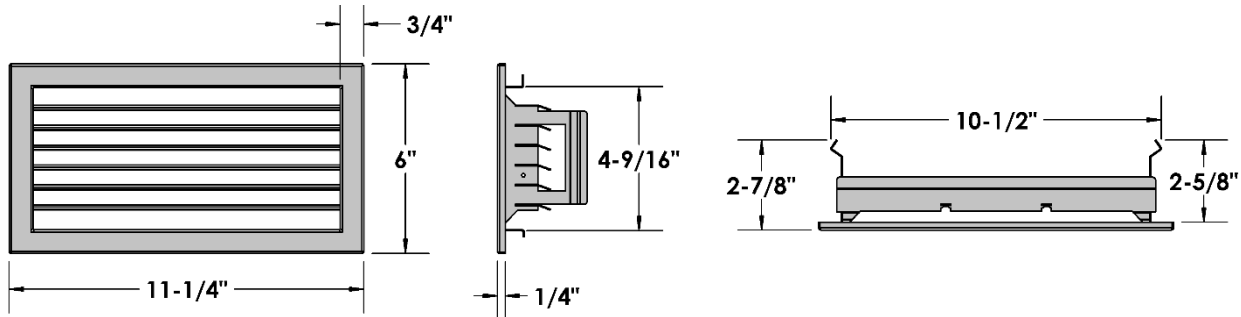

Installation: Insert Grills into openings and fasten to framing with a wood screw at each end.

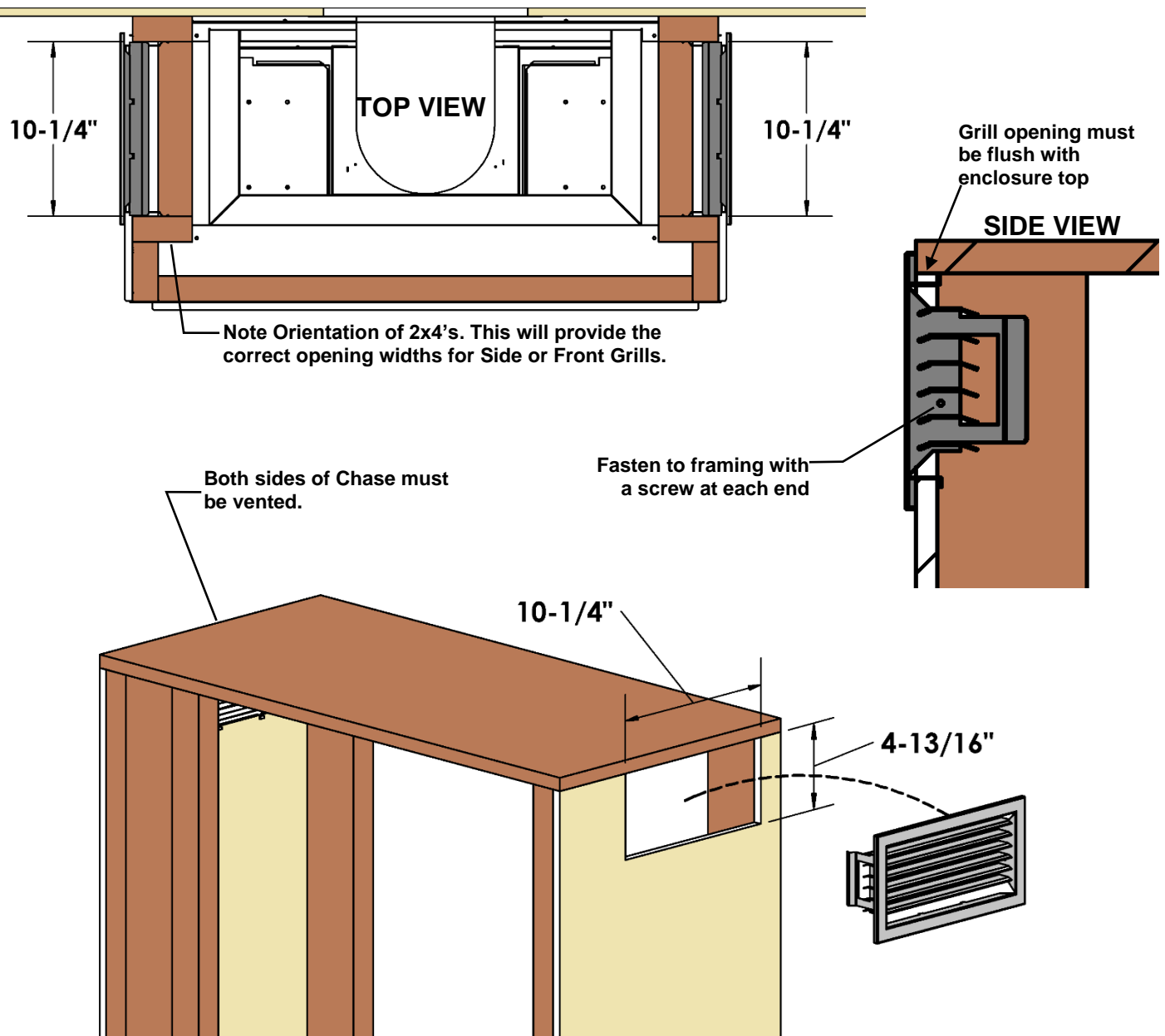

MQZCVBG34

-Facing Requirements

Unit may be covered with combustible material (i.e. drywall) up to the fireplace opening.

FIREPLACE CHASE MUST BE VENTED AT THE TOP OF THE ENCLOSURE.

- Minimum 90 square inches free air opening for grills (V34EG & V34EGS).
- Minimum 2-1/8" Gap at top of enclosure for Open Top chases.

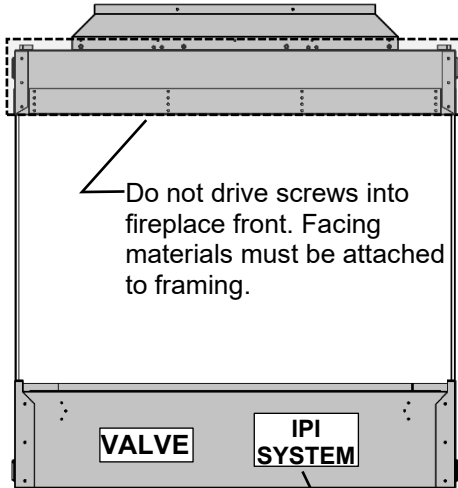

Do not drive screws into these highlighted areas.

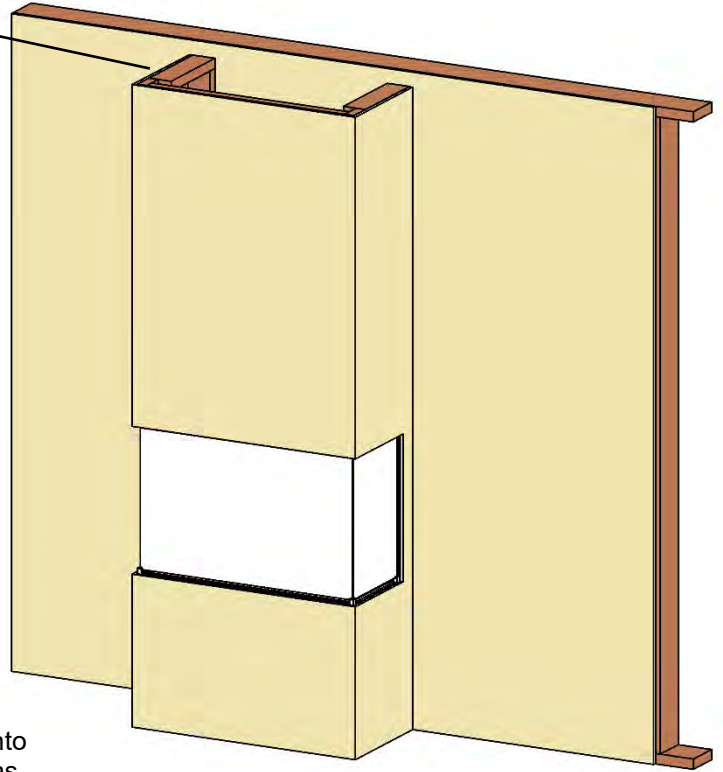

MQZCVBG34

- Using Tile Lip

A Tile Lip is supplied for attachment above the fireplace opening only. This can be used as a standard tile edging or as a mount bracket for other surfaces like drywall or plywood.

Set to desired height and attach through holes in face of fireplace.

For a complete Tile Lip Kit order ZBG34-TLK.

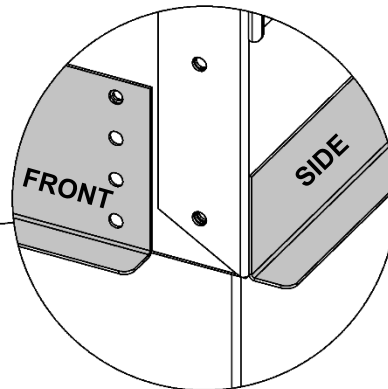
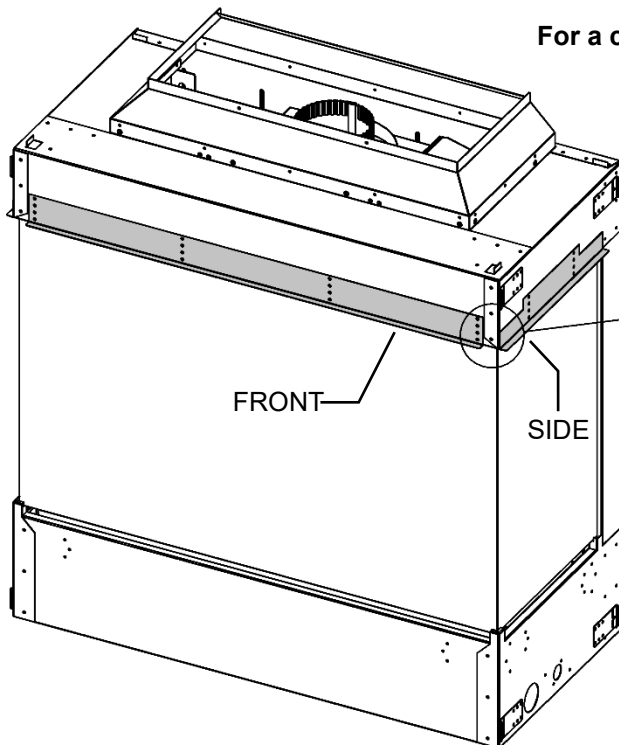

ZCV34BGCK Corner Kit

Option

- MUST BE INSTALLED BEFORE UNIT IS INSTALLED INTO FRAMING.
- CORNER KIT CAN BE INSTALLED AT EITHER END OF FIREPLACE.

⚠ Warning: Failure to position the parts in accordance with these diagrams or failure to use only parts specifically approved with this appliance may result in property damage or personal injury.

Contents of Kit:

- Inner Liner Panel
- Front Glass Cover with Gasket
- Firebox Cover with Gasket
- Front Side Cover
- Fireplace Outer Cover
- 90ml Tube Mill-Pac
- [Qty 34] 1/2" DT Screws

Sheet Metal Components:

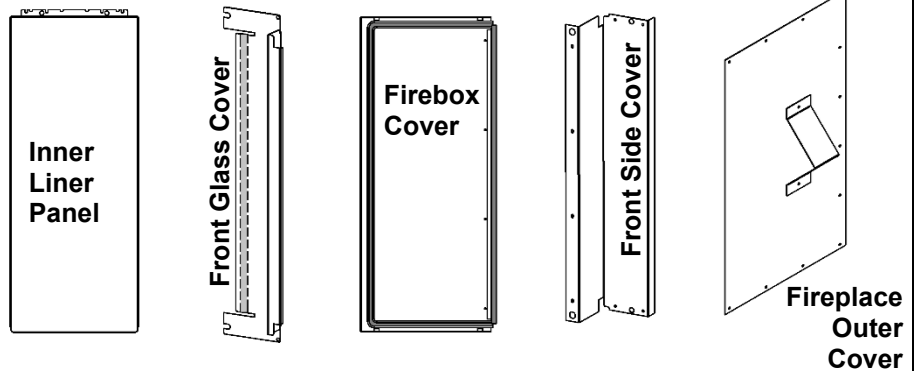

STEP ONE- PREPARATION

- A.** Remove Front Firebox Glass.
- B.** Remove the Side Door Retainers, Firebox Side Glass Panel and Door Frame and discard.
- C.** Cut and remove Side Firebox Gasket 1/4" past the corner edges.

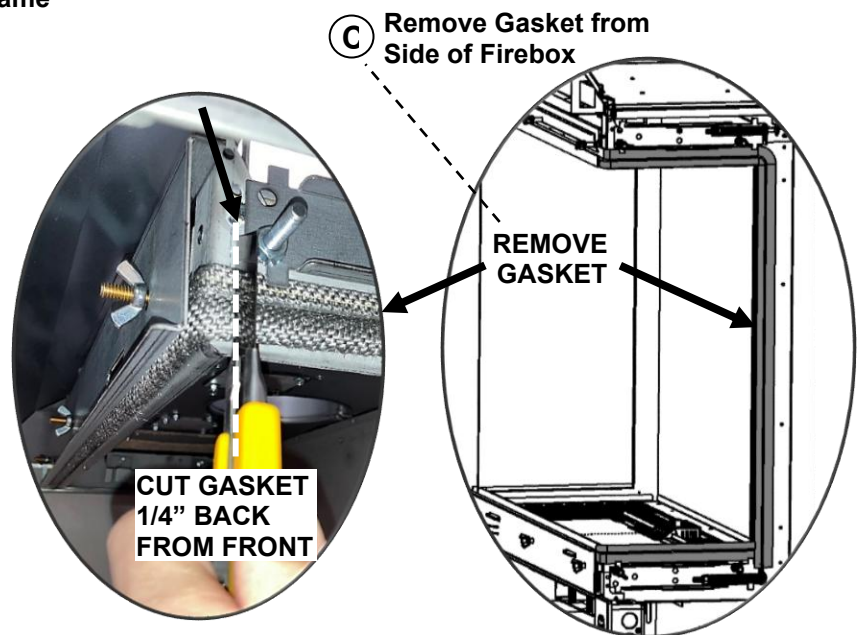
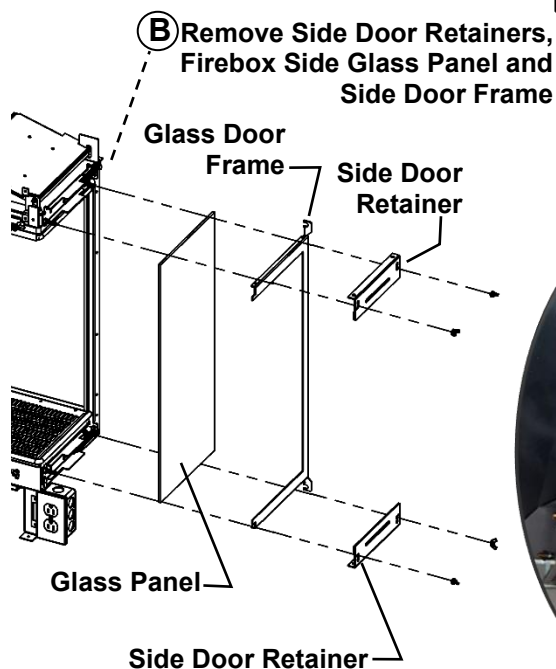
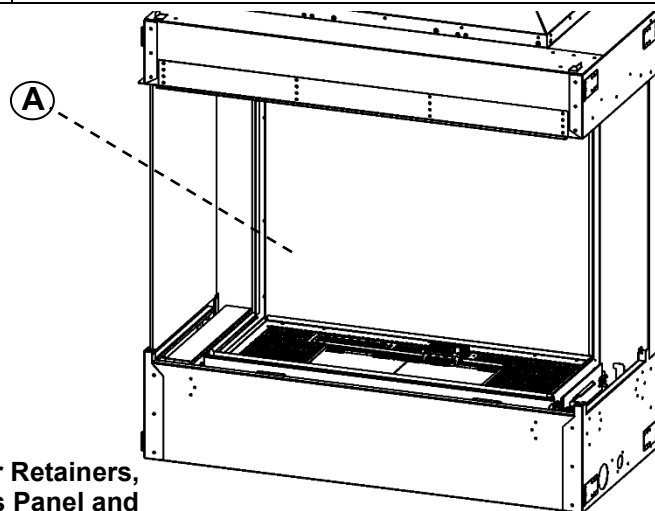

- CONTINUED ON NEXT PAGE -

STEP TWO: INSTALL FIREBOX COVER

- D.** Apply a 3/8" bead of Mill-Pac onto the Seal Gasket of the Firebox Cover. Do not Apply Mill-Pac onto the Front Glass Gasket.
- E.** Insert Firebox Cover through front of fireplace and press against **Back and Side** of firebox.
- F.** Check inside firebox to ensure that Seal Gasket and Mill-Pac are sealed against the side of the firebox. Front Glass Gasket must be flush with front of firebox.
- G.** Attach the Firebox Cover with supplied DT Screws.

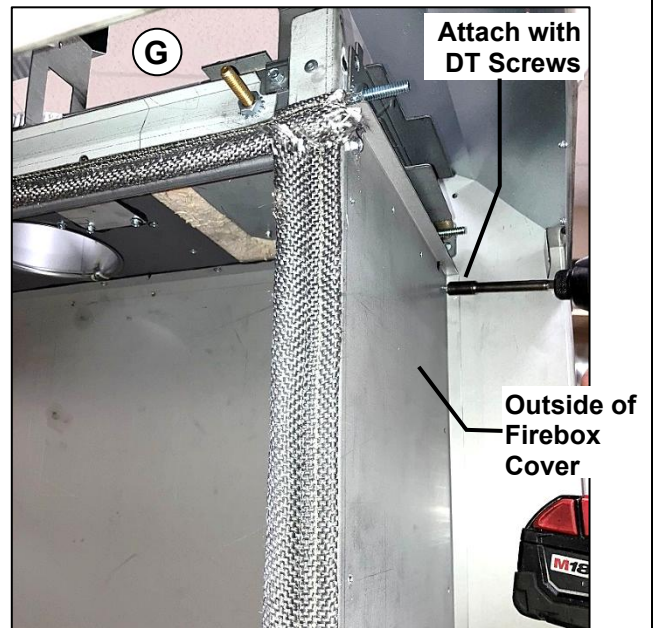
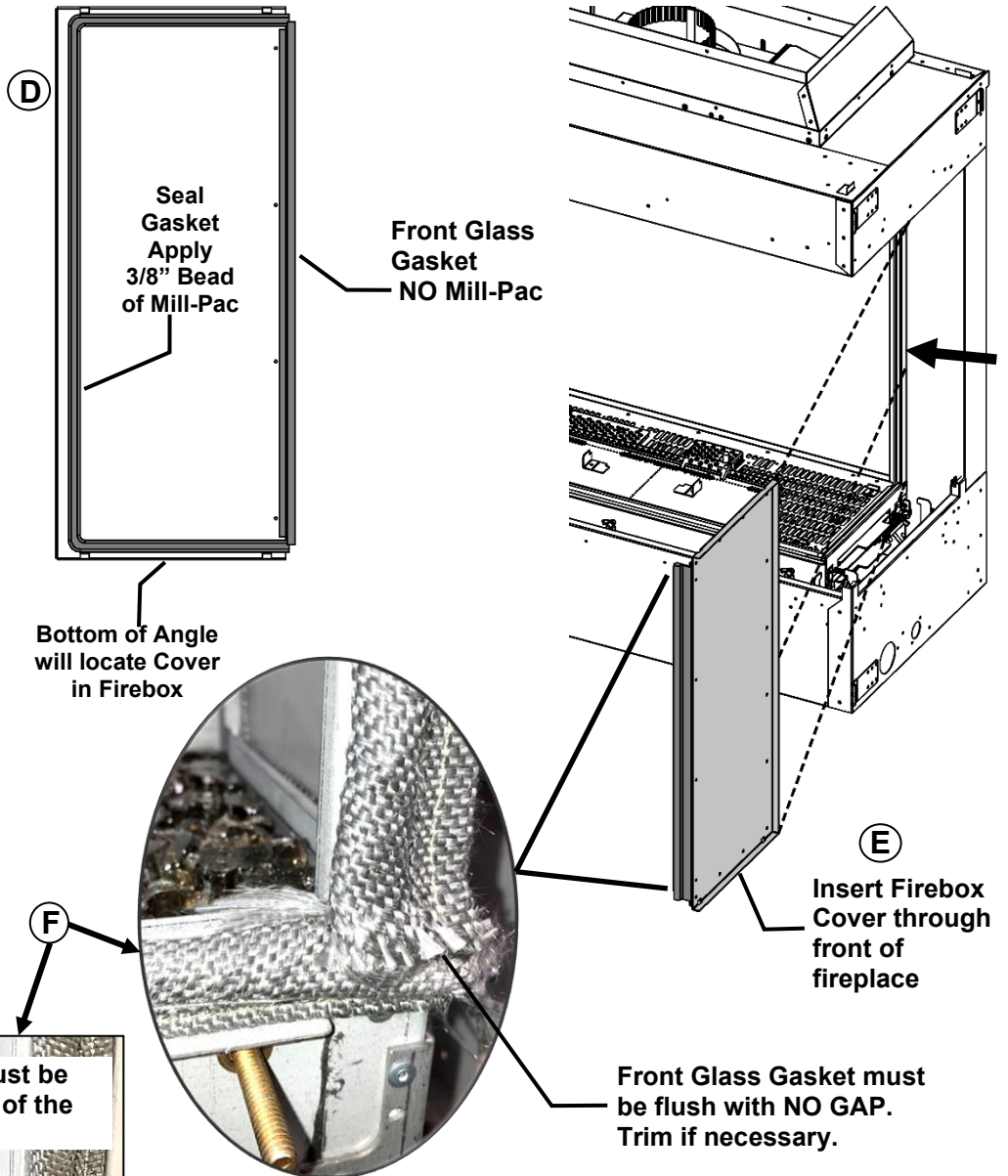

- CONTINUED ON NEXT PAGE -

STEP THREE: INSTALL FRONT SIDE COVER

- H.** Insert Front Side Cover through front of fireplace and attach to Firebox Cover with supplied DT Screws.

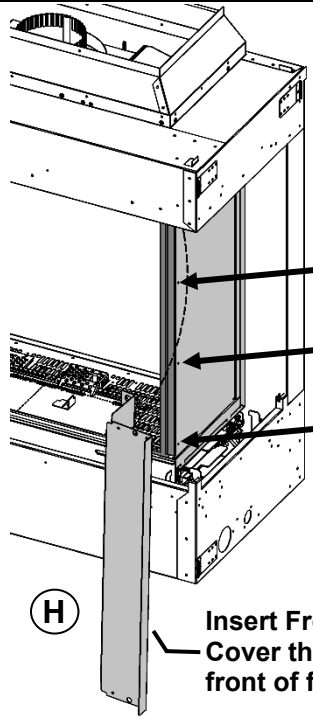

Attach Front Side Cover with DT Screws

STEP FOUR: INSTALL FIREPLACE OUTER COVER

- I.** Use [12] DT Screws to attach Fireplace Outer Cover.
- J.** Set Stand-Off in position and attach with DT Screw.

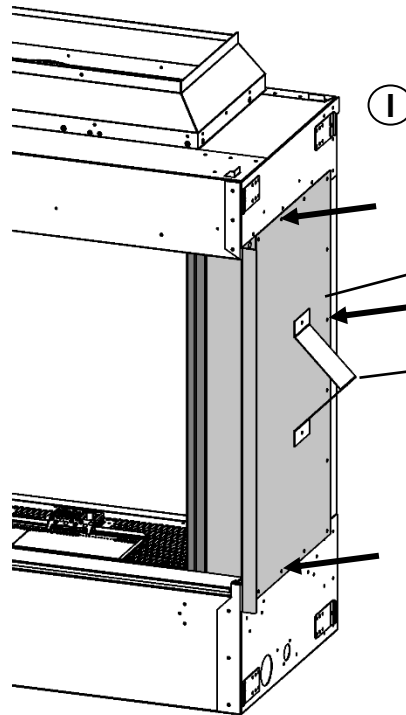

I Use [Qty 12] DT Screws to attach Fireplace Outer Cover

J Set Stand-Off in position and attach with DT Screw.

STEP FIVE: INSTALL INNER LINER PANEL

NOTE: Do not install this component if you are using optional fiber or reflective glass side liners.

- K.** Install Inner Liner Panel inside of Firebox.

K Install Inner Liner Panel inside of firebox

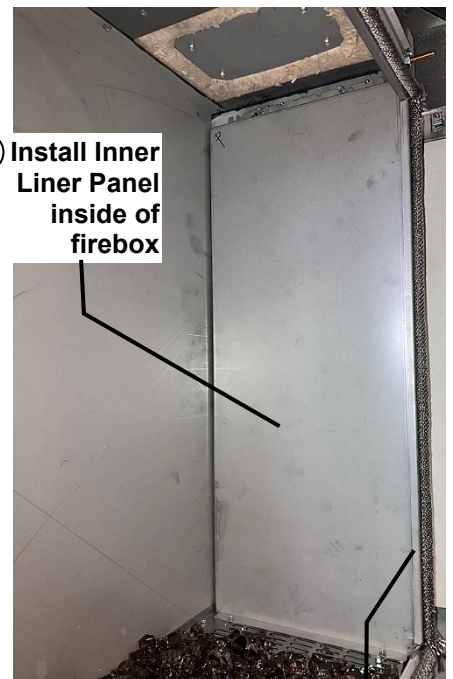

Front Glass Gasket

- CONTINUED ON NEXT PAGE -

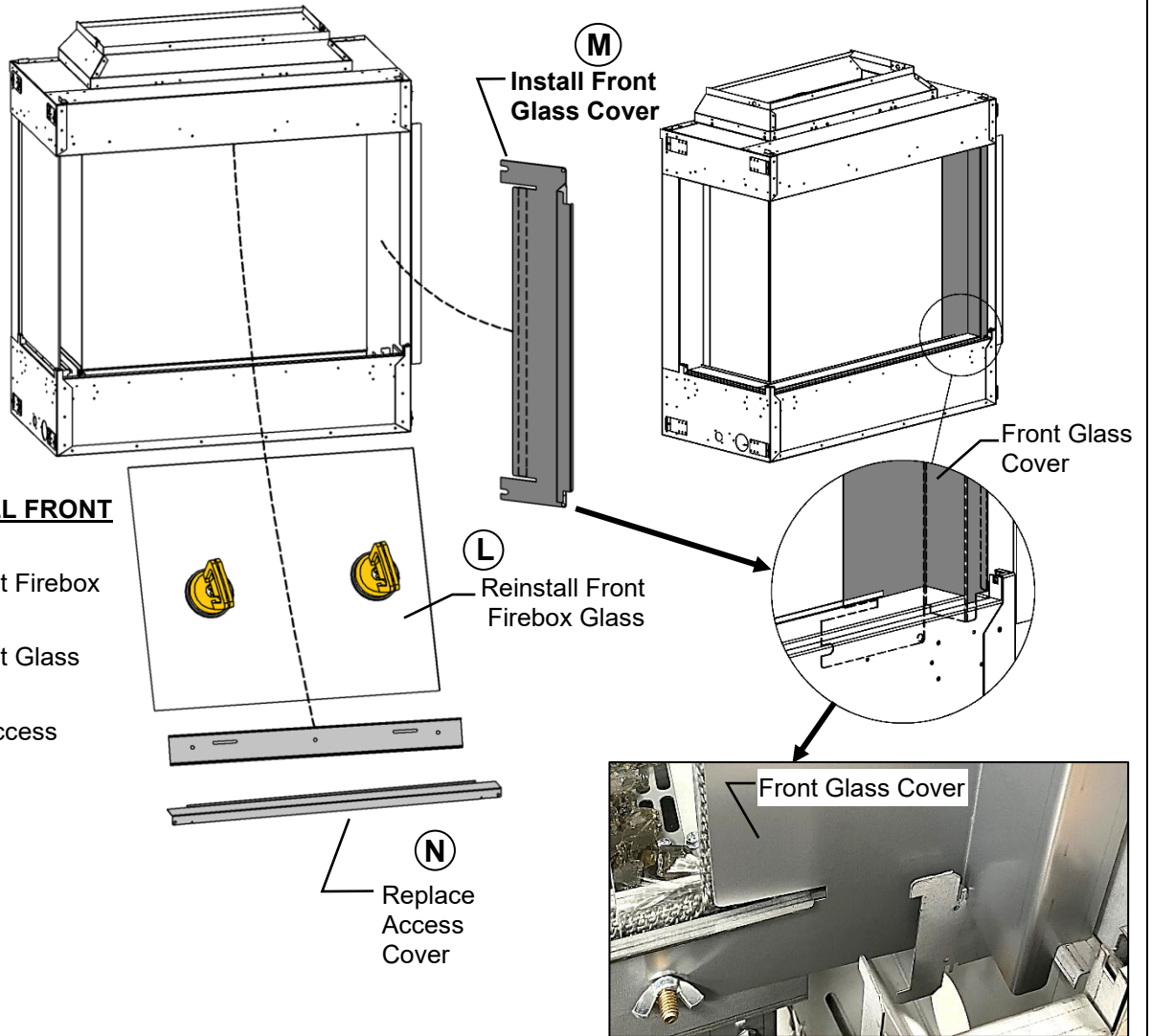

FRAMING:
Refer to Corner Framing Section of manual.

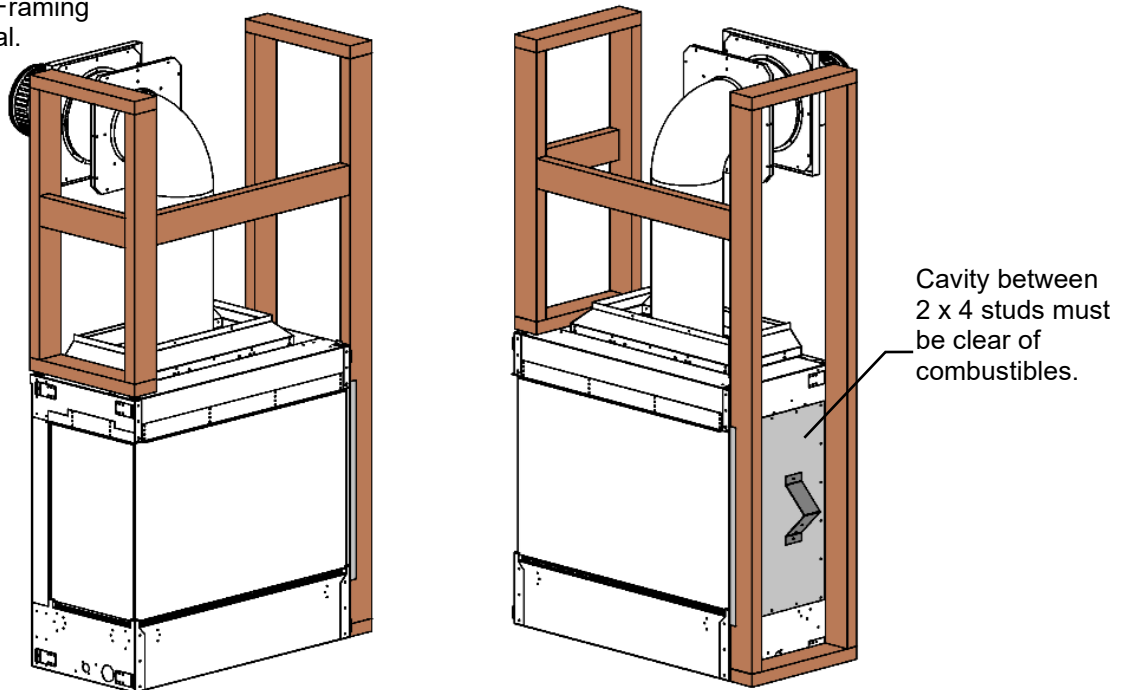

MQZCVBG34

- Side Glass Removal and Installation

Remove Front Firebox Glass first. If the Side Glass Panel or another component must be cleaned or replaced, remove the 4 Wing Nuts from the Side Glass Door and remove Retainers, Glass Door Frame, and Glass.

⚠ IMPORTANT: Front corners must have a dab of high-temp silicone placed between the ball of the gasket and the glass. This will fully seal the firebox corners.

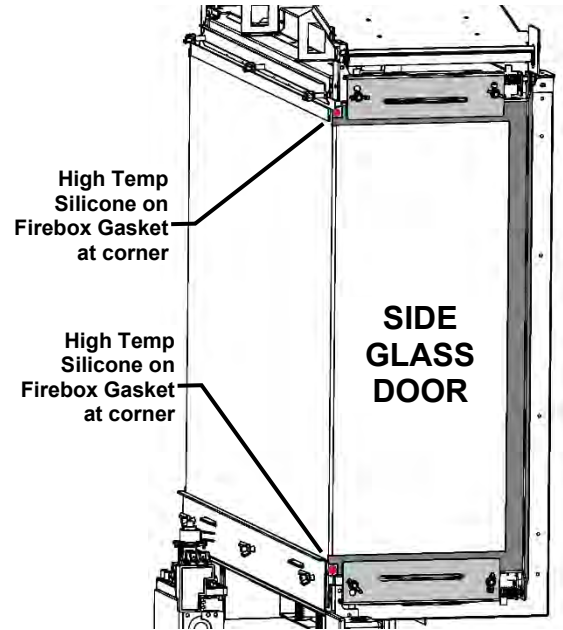
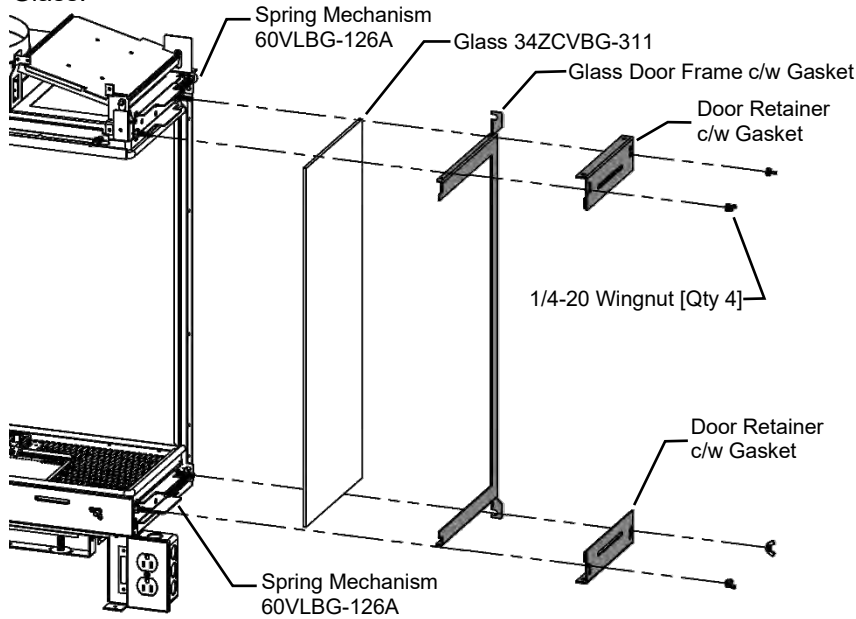

To Reinstall Side Glass Door:

1. Install Glass Door Frame onto firebox by engaging slots in Door Frame behind the heads of the Carriage Bolts on the upper and lower Spring Mechanisms.
2. Install Door Retainers and Wingnuts. Do not fully tighten Wingnuts until Firebox Front Glass Panel is installed.
3. Proceed to Front Glass Installation Instruction.

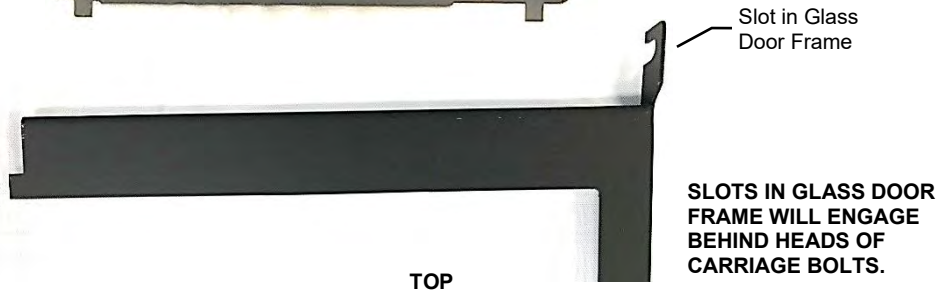
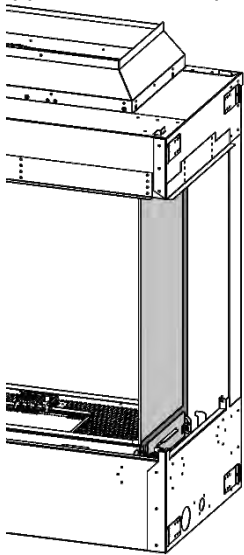

TOP



BOTTOM

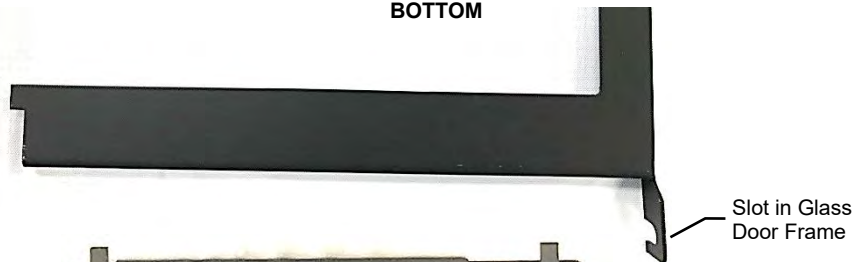

Carriage Bolt

Replacement Part:
Spring Mechanism
60VLBG-126A

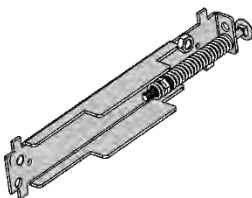

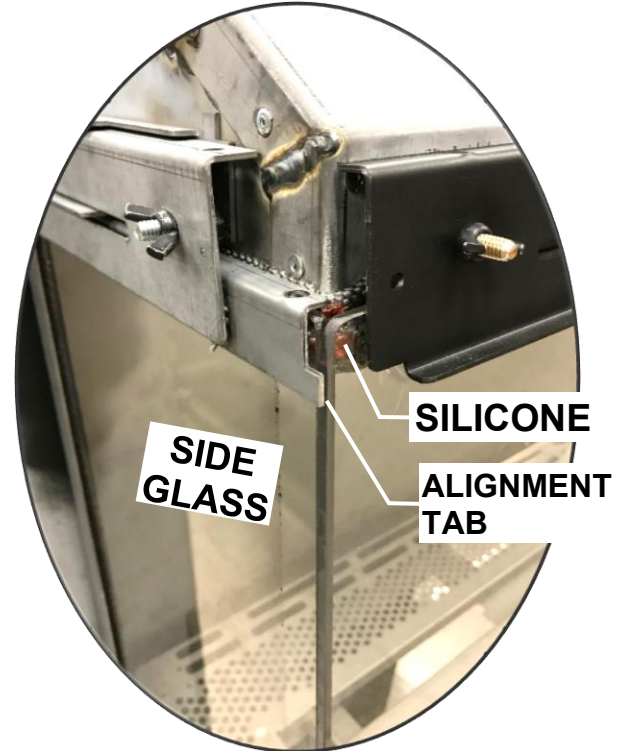
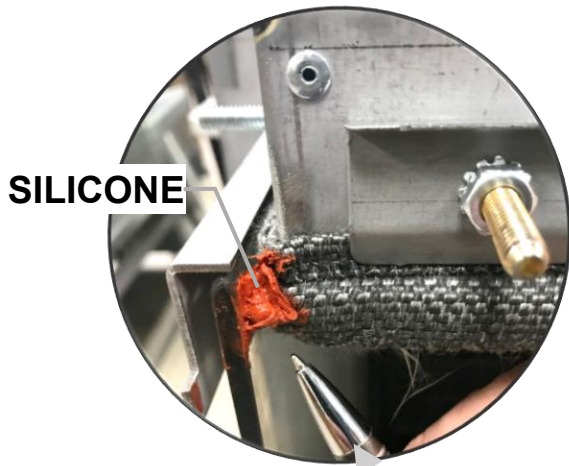

⚠ IMPORTANT: Each corner must have a dab of high-temp silicone placed between the ball of the gasket and the corner glass. This will fully seal the firebox corners.

Front Glass is placed in front of corner glass edge.

NOTE: Side Glass Panels must be in place before Front Glass is installed.

To Install Glass Front:

1. Loosen Upper and Lower Side Glass Retainer wing nuts until they are only lightly snug (See **A** and **B** at right).
2. Place a bead of High Temp Silicone on all four corners of the firebox gasket (see above). This will seal any gaps between where the gasket and the glass corners meet.
3. Install Glass Front into the Lower Glass Retainer. Install Upper Glass Retainer. Tighten wing nuts until lightly snug. **Start at the center and work toward the ends of the glass.**
4. Match Glass Front up with Side Glass at each end using Alignment Tabs (See above).
5. Tighten wing nuts on Glass Front until they are snug. Next, fully finger-tighten wing nuts on Side Glass, and then back them off 1/4 to 1/2 turn. Finally, finish tightening all wing nuts on Glass Front.

NOTE: Do not over tighten nuts as glass could break.

Wingnuts should be finger-tight on Glass Front.

To Remove Glass Front:

1. Remove Wing Nuts on the Upper Glass Retainer and remove the retainer.
2. Loosen Wing Nuts on the Lower Glass Retainer but do not remove. Glass Front can now be lifted out of the fireplace.

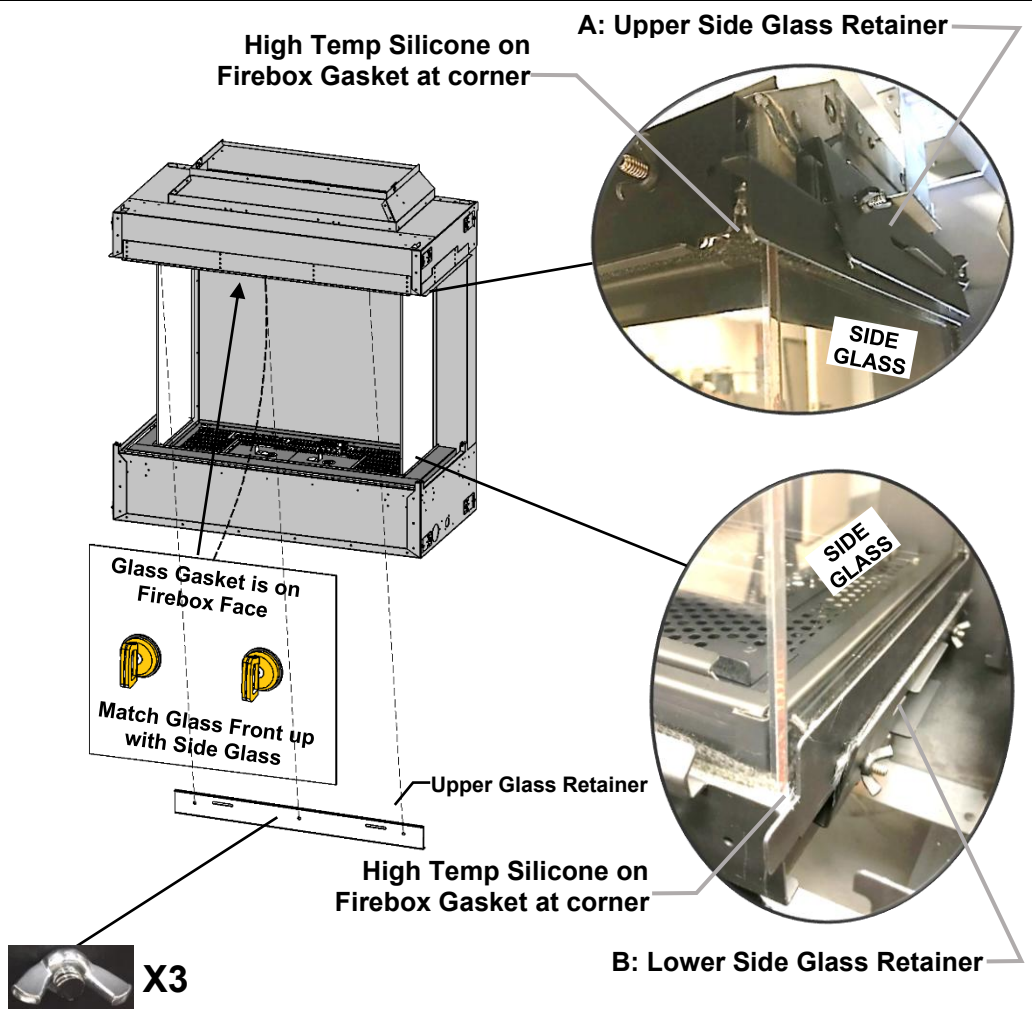

Glass Cleaning

It will be necessary to clean the glass periodically. During startup, condensation, which is normal, forms on the inside of the glass, and causes dust, lint etc. to cling to the glass surface.

Also, initial paint curing can deposit a slight film on the glass. It is therefore recommended that initially the glass be cleaned two or three times with a fireplace glass cleaner. After that, the glass should be cleaned two or three times a season depending on the circumstances.

**Cautions and Warnings**

- Do not clean when the glass is hot.
- The use of substitute glass will void all product warranties (see **Glass Replacement** in this section).
- Care must be taken to avoid breakage of the glass.
- Do not operate this fireplace without the glass front or with a broken glass front.
- Do not strike or abuse the glass.

Glass Replacement - Firebox

Only Robax ceramic or coated Neoceram glass may be used for replacement. Glass must be minimum 5mm thick. **Be sure to purchase glass from an authorized dealer.**

To replace glass, remove old gasket and clean glass. Peel backing from new gasket and install as shown below.

**Use caution when working with glass. Wear gloves.
Suction Cups Recommended.**

Removal of the Glass Front: Refer to ***Glass Door Front Removal / Installation*** section of this manual.

1. Remove nuts with a 3/8" wrench.
2. Remove Glass Door.

Removal of the Glass Side Doors: Refer to ***Glass Door Side Removal*** section of this manual.

1. Remove nuts with a 3/8" wrench.
2. Remove Glass Door.

Glass Replacement – Safety Glass Barrier

Only Tempered Low E Glass may be used, and coated side of glass must face toward firebox.

Be sure to purchase glass from an authorized dealer.

Refer to ***Glass Safety Barrier Installation / Removal*** section of this manual.

**Use caution when working with glass. Wear gloves.
Suction Cups Recommended.**

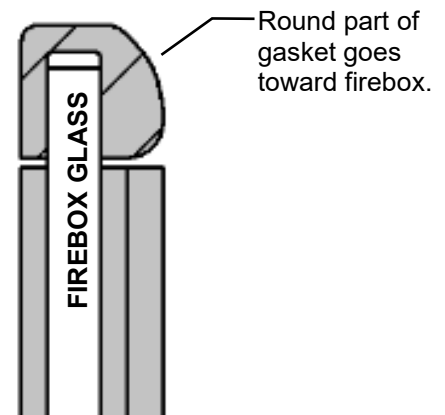

Suction Cups Recommended



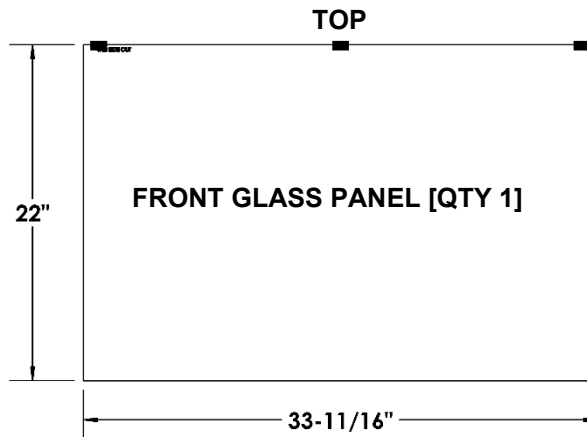
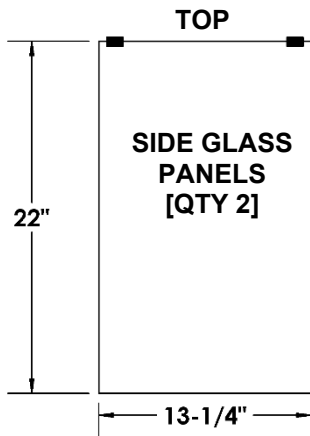

Install side glass first. Repeat procedure for front glass.

- Insert top of glass into clips in top of fireplace
- Bottom of glass will rest in Glass Supports.
- **“THIS SIDE OUT”** etching must face outward.

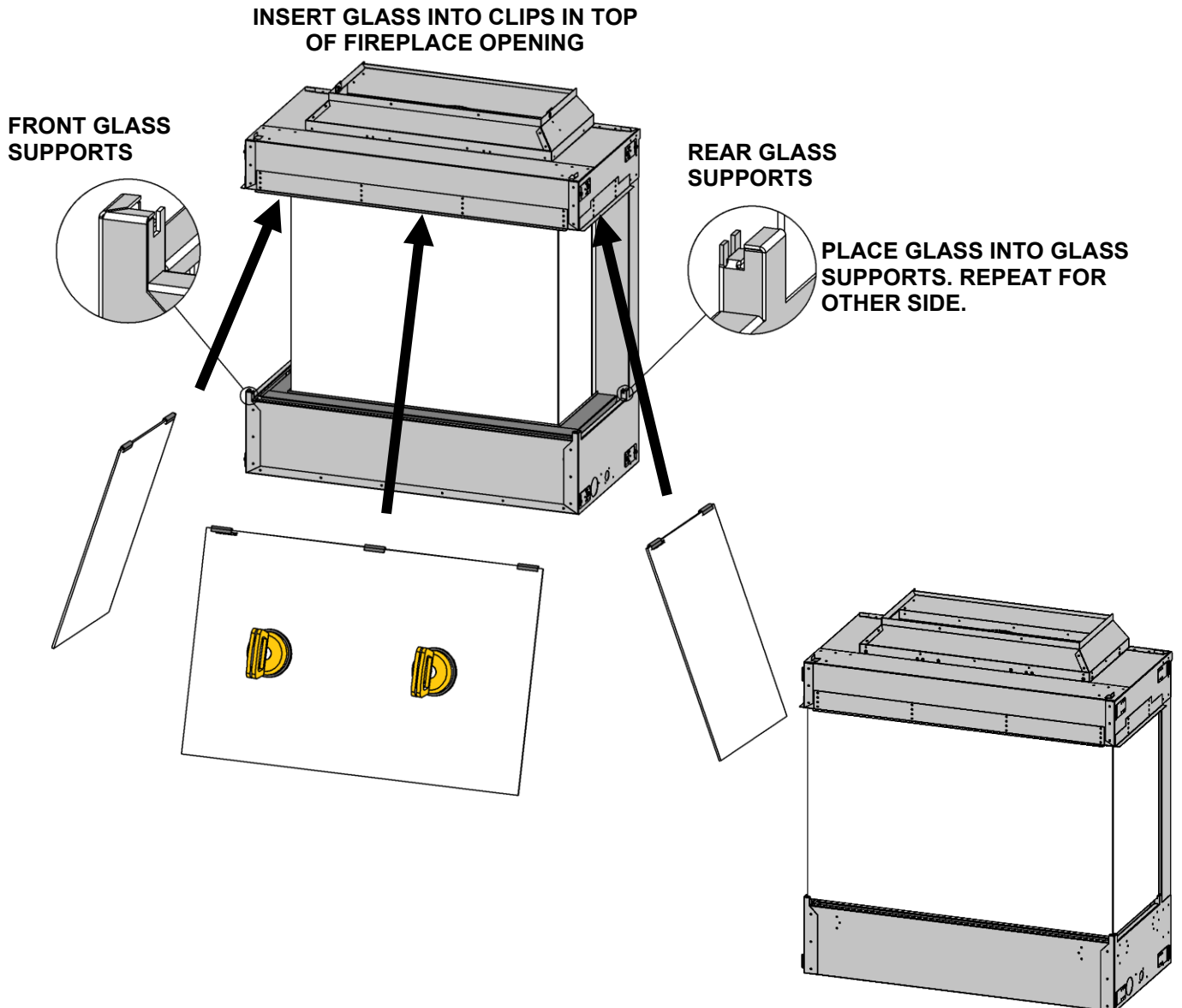

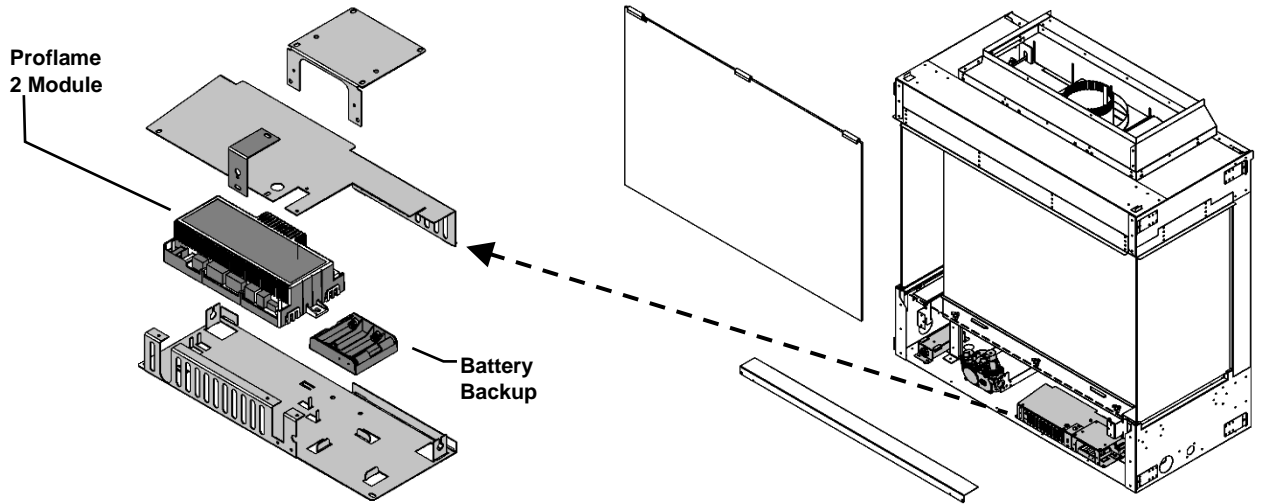

Component Box can be inserted & removed from beneath fireplace through access panel opening (Remove glass door first).

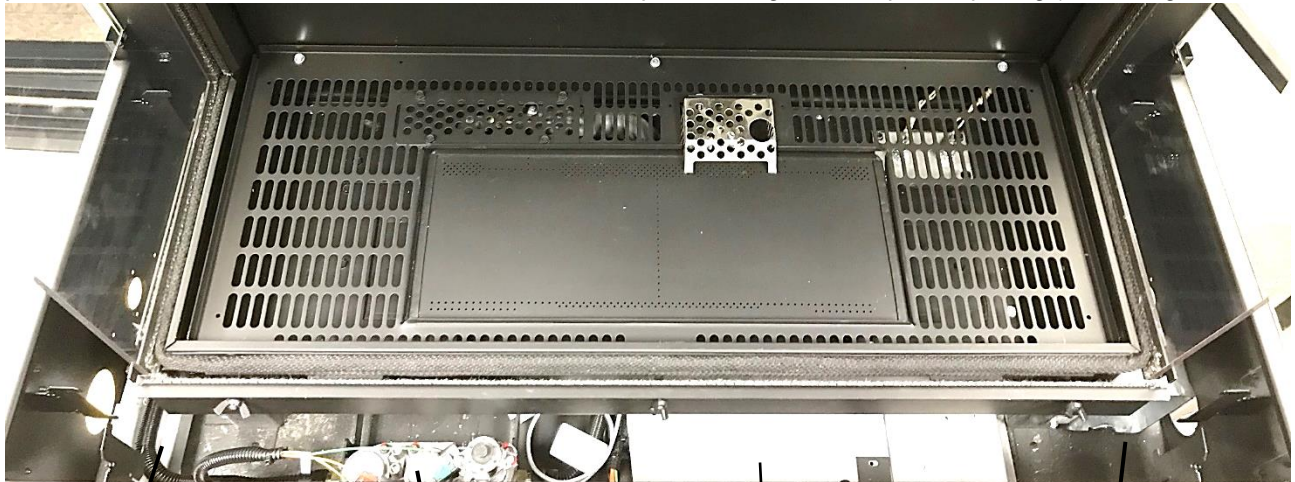

Lamp Transformer Valve Component Box Receptacle

Primary Air Adjustment Access

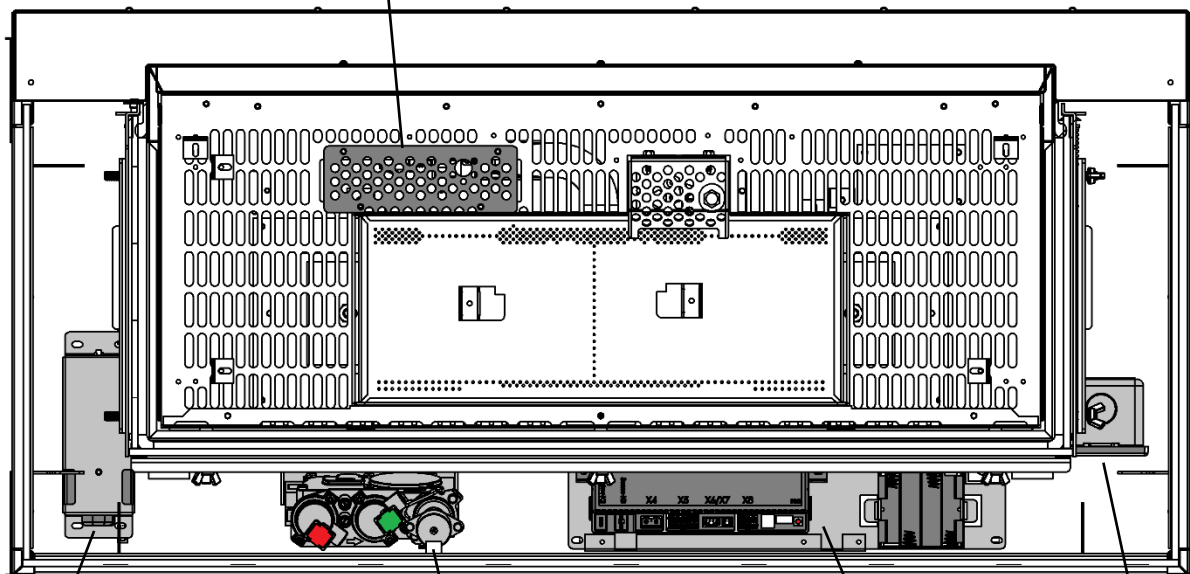

Lamp Transformer Valve Component Box Receptacle

34ZCVBG-TLK Tile Lip Kit

- Optional

The TLK Kit may be used as a trim around the opening of the fireplace. Fasten with supplied self-tapping screws.

| ITEM NUMBER | QUANTITY | PART NUMBER | DESCRIPTION |
|--|----------|-------------|--|
| Kit Consists of items 1-4 | | | |
| 1 | 1 | 34ZCV-TLK1 | Front Bottom Tile Lip 34-7/16" |
| 2 | 2 | 34ZCV-TLK2 | Side Horizontal Tile Lip 14-7/16" |
| 3 | 2 | 34ZCV-TLK3 | Side Vertical Tile Lip 21-5/8" |
| 4 | 23 | 530-685 | #8-1/2" Self-Tapping Screw |
| Items 5 & 6 are supplied with Fireplace | | | |
| 5 | 1 | 34ZCVBG-164 | Front Top Tile Lip 32-1/16" (Supplied with Unit) |
| 6 | 2 | 34ZCVBG-165 | Side Top Tile Lip 13-3/4" (Supplied with Unit) |

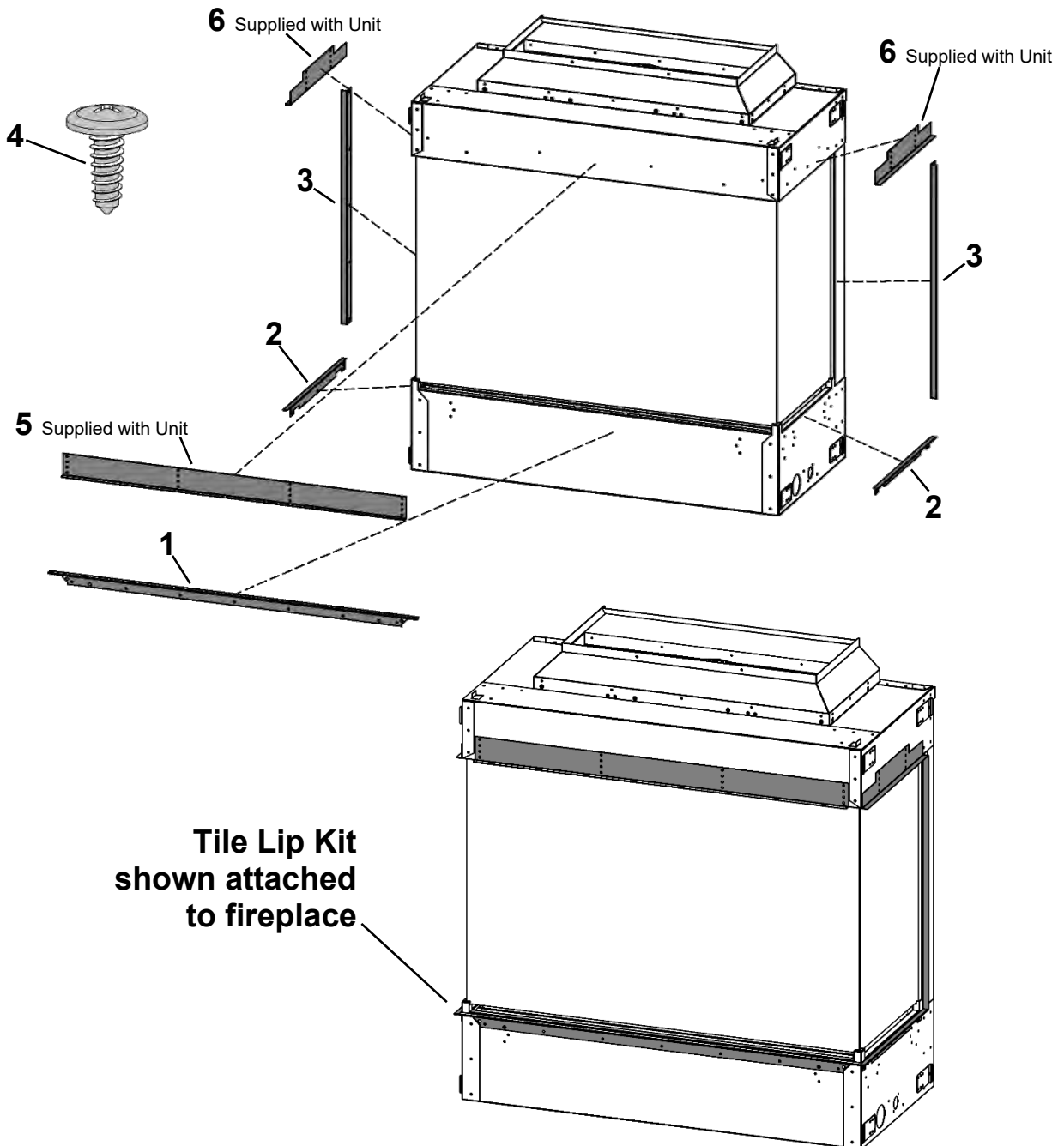

MQZCVBG34 Proflame 2 Units - ULK5-2 Halogen Lights - Factory Installed

Please follow the current ANSI/NFPA 70 National Electrical Code in the USA and CAN/CSA C22.1 Canadian National Electrical Code in Canada.

Contents of Kit:

- [2] 12V Halogen Lamps
- Lamp Plate with Insulated Studs & wiring
- 12VAC Transformer with wire connectors

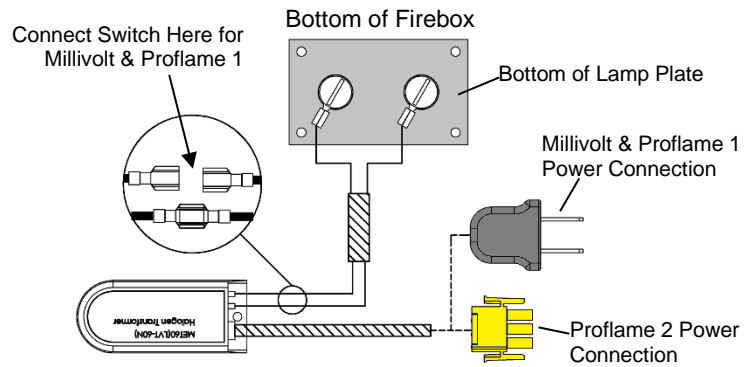
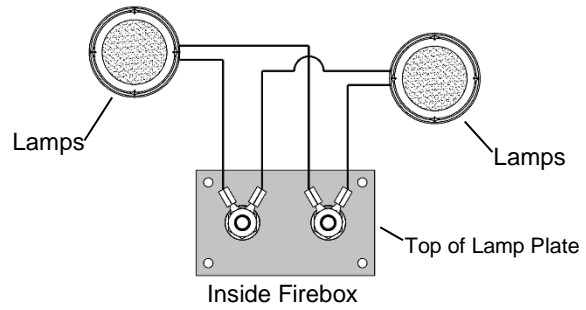
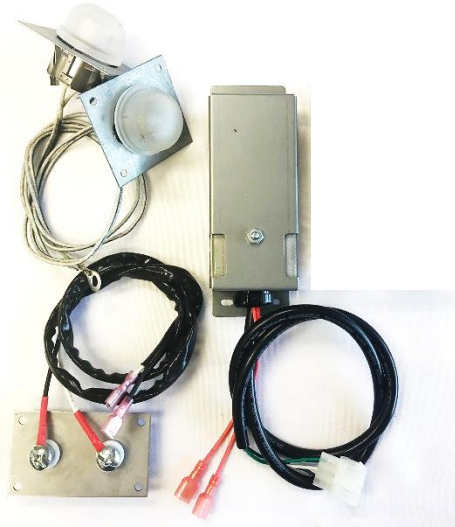

STEP 1: Remove Media Tray and Cover Plate. Place ULK Transformer in position.

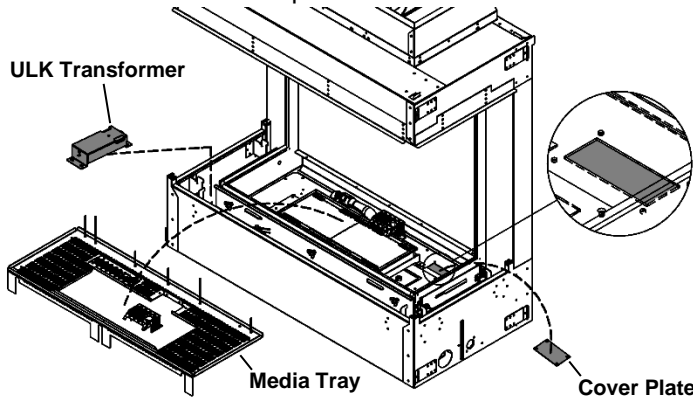

STEP 2: Remove old sealant around exposed opening. Apply New Sealant (Mill-Pac). Insert wires on Lamp Plate through opening. Secure Lamp Plate with screws.

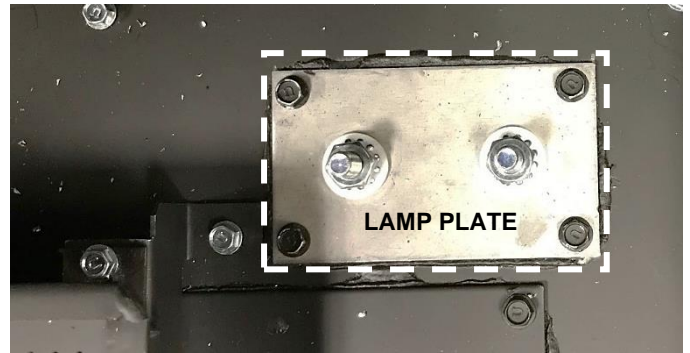

STEP 3: Wire Connections- Refer to schematic at top right of page.

Connect wires from Bottom of Lamp Plate to Red wires on ULK Transformer.

Proflame 2- Plug Yellow connector into White lead from Proflame 2 Module.

See next page for Lamp installation in firebox.



STEP 4:

Install Lamp Assemblies in Firebox Top as shown.

NOTE: Install One Lamp Assembly at a time to avoid confusion when connecting wires to Lamp Plate in Step 5.

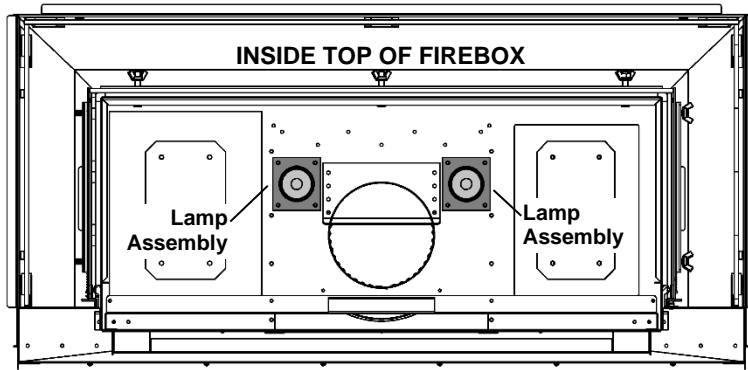

STEP 5: Take wires from rear bottom of firebox and **CONNECT ONE TO EACH STUD ON LAMP PLATE.** Repeat Steps 4 and 5 for the second Lamp Assembly.

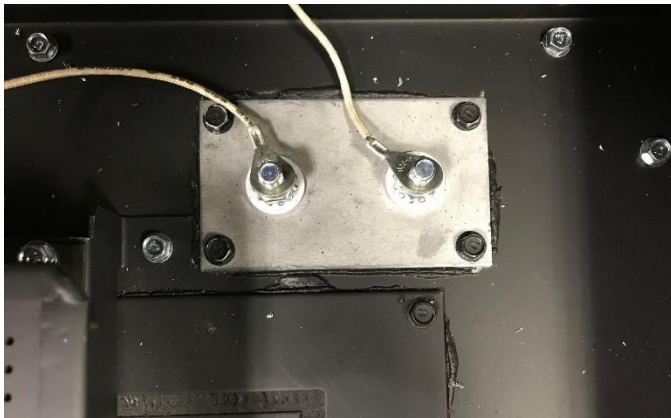

ONE LAMP ASSEMBLY CONNECTED



BOTH LAMP ASSEMBLIES ARE CONNECTED

CONTENTS:
[3] GLASS BACK LINERS

NOTE: Install Glass Back Liners **Before** installing Glass Side Liner from Corner Kit.

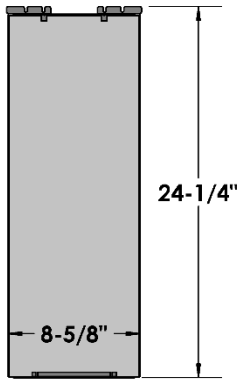

STEP ONE: Remove Liner Clip and screws from inside of firebox with a 1/4" hex driver. Discard Back Clip but **Keep Screws**.

CAUTION
-NOT TEMPERED GLASS-
-EXTREMELY FRAGILE-
-HANDLE WITH CARE-

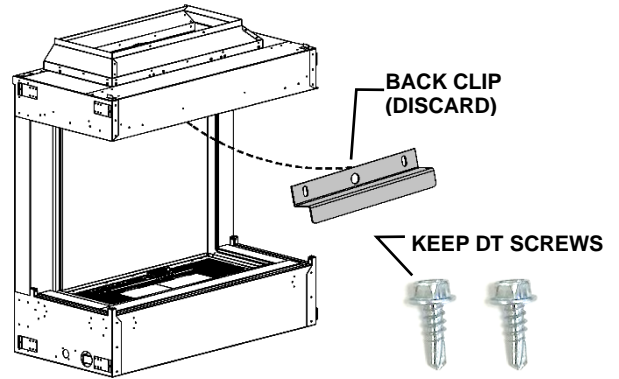

STEP TWO: Bend down tabs at back corners of False Bottom to give clearance for End Panels.



NOTE: Remove [Qty 4] Lower Liner Clips Attached to Media Tray. Keep DT Screws. Lower Liner Clips may be discarded.

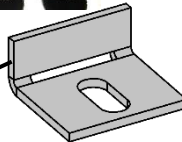

STEP THREE: First install a Glass Back Liner against back wall of firebox at either end. Next install a Glass Back Liner in the center.

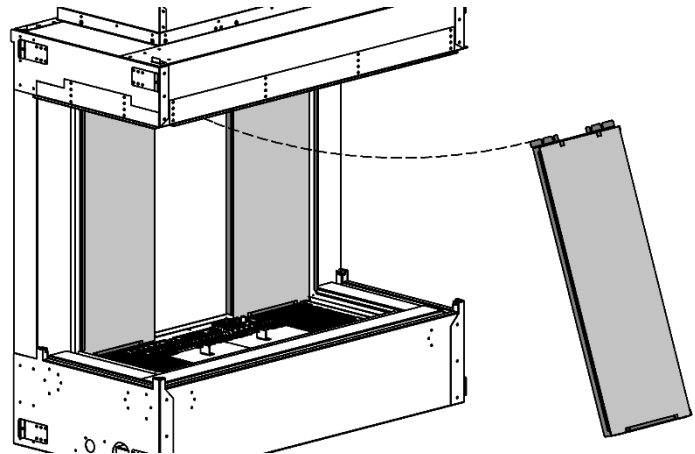

STEP FOUR: Attach top and bottom of liners with DT Screws.

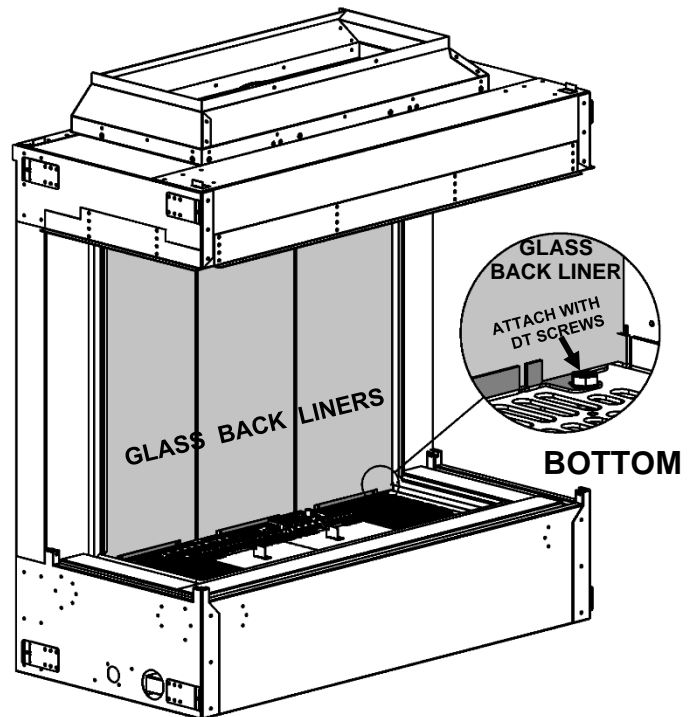
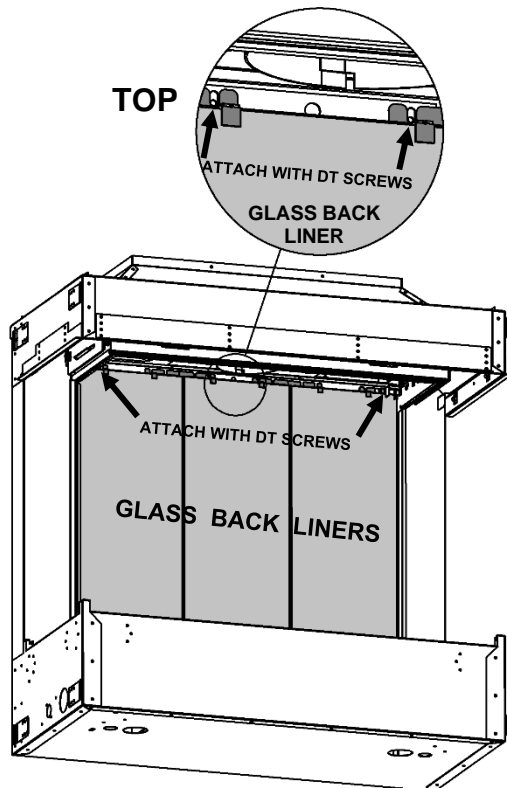

⚠ Note: Discoloration of Glass Liners Is Not Covered Under Warranty.

Glass Liners may discolor during normal operation of your appliance. This is normal, and not considered a defect.

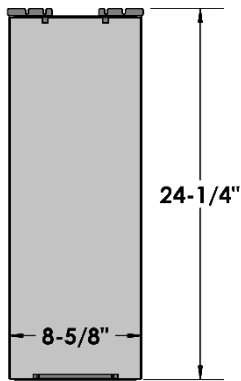

Contents of Kit:
[1] Glass Side Liner

**⚠ CAUTION – NOT TEMPERED GLASS-
EXTREMELY FRAGILE – HANDLE WITH CARE**

NOTE: ZCV34BGCK Corner Kit required. Glass Back Liner must be installed first.

NOTE: If using **CORNER KIT** and you are **NOT** installing a Glass Side Liner, install Inner Liner Panel from Corner Kit before Glass Back Liner. However, if you **ARE** installing a Glass Side Liner, do not install Inner Liner Panel from the Corner Kit.

STEP ONE: Insert Glass Side Liner into firebox.

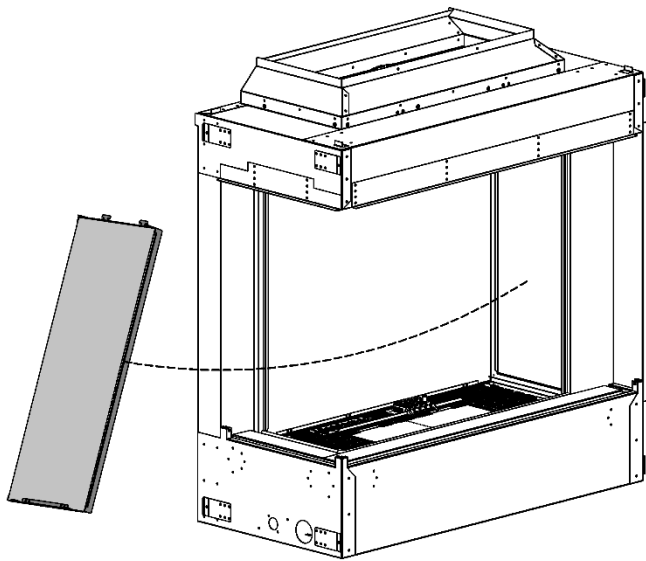

STEP TWO: Set Glass Side Liner in position against side wall of firebox.

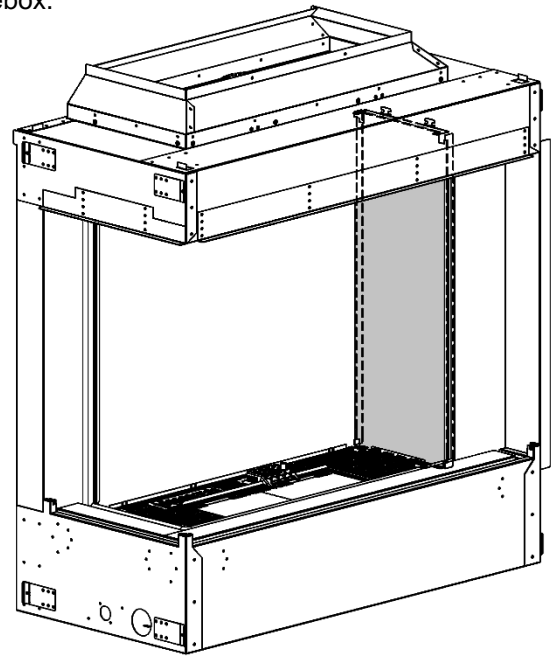

STEP THREE: Attach top and bottom of Glass Side Liner with DT Screws as shown below.

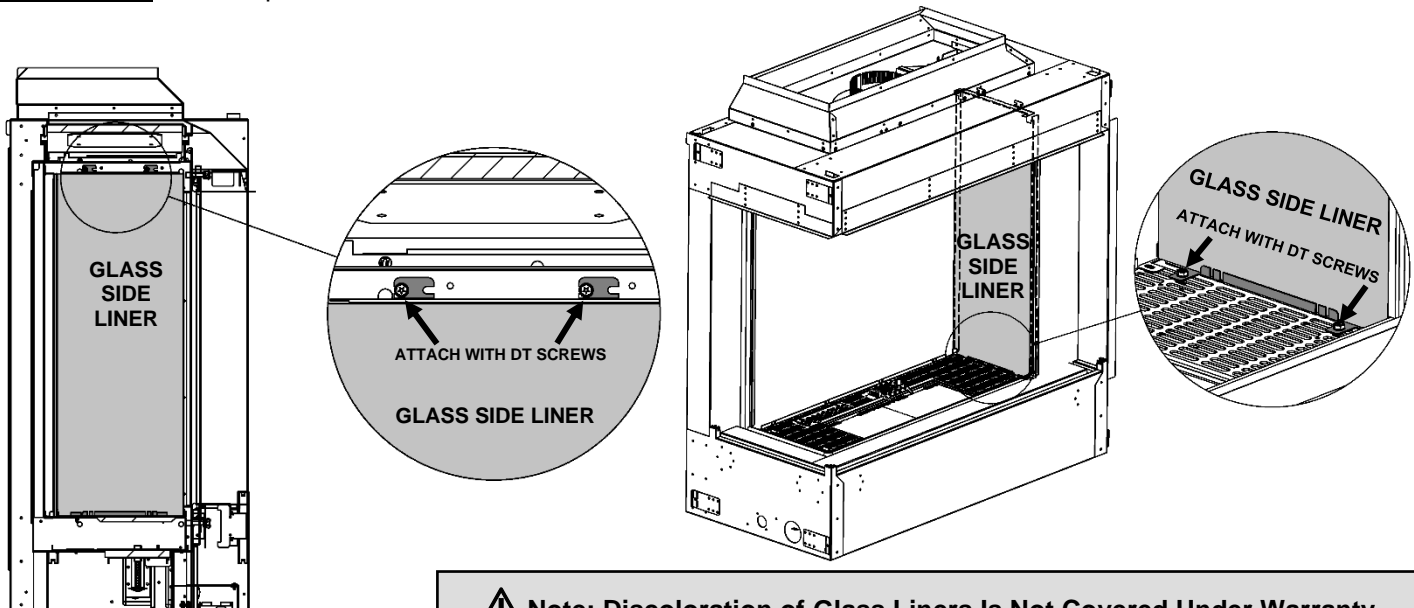

⚠ Note: Discoloration of Glass Liners Is Not Covered Under Warranty.
Glass Liners may discolour during normal operation of your appliance.
This is normal, and not considered a defect.

MQZCVBG34 Refractory Back Liner Installation

Option

CONTENTS:

[1] BACK LINER

NOTE: Install Back Liner **Before** installing Side Liner.

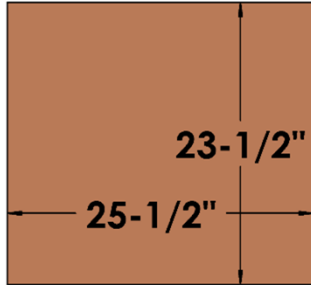

STEP ONE:

Remove Brick Liner Clips and screws from inside of firebox with a 1/4" hex driver.

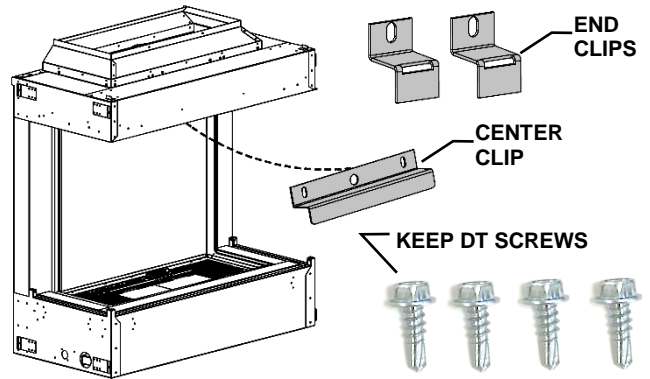

STEP TWO: Remove [Qty 4] Lower Liner Clips Attached to Media Tray.



STEP THREE: Install Back Liner against back wall of firebox.

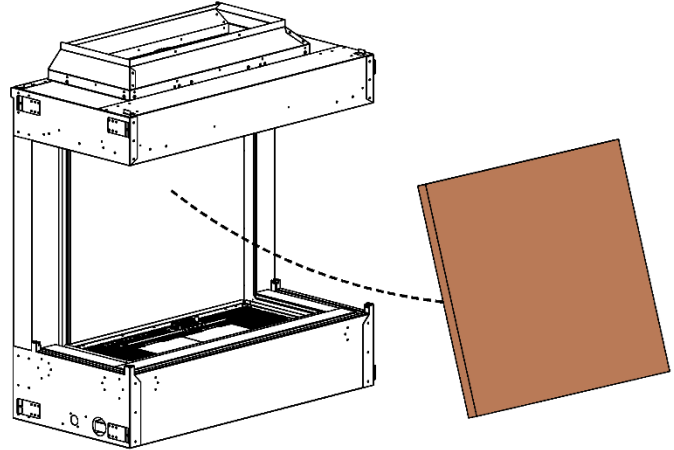

STEP FOUR: Attach top and bottom with Brick Clips and DT Screws.

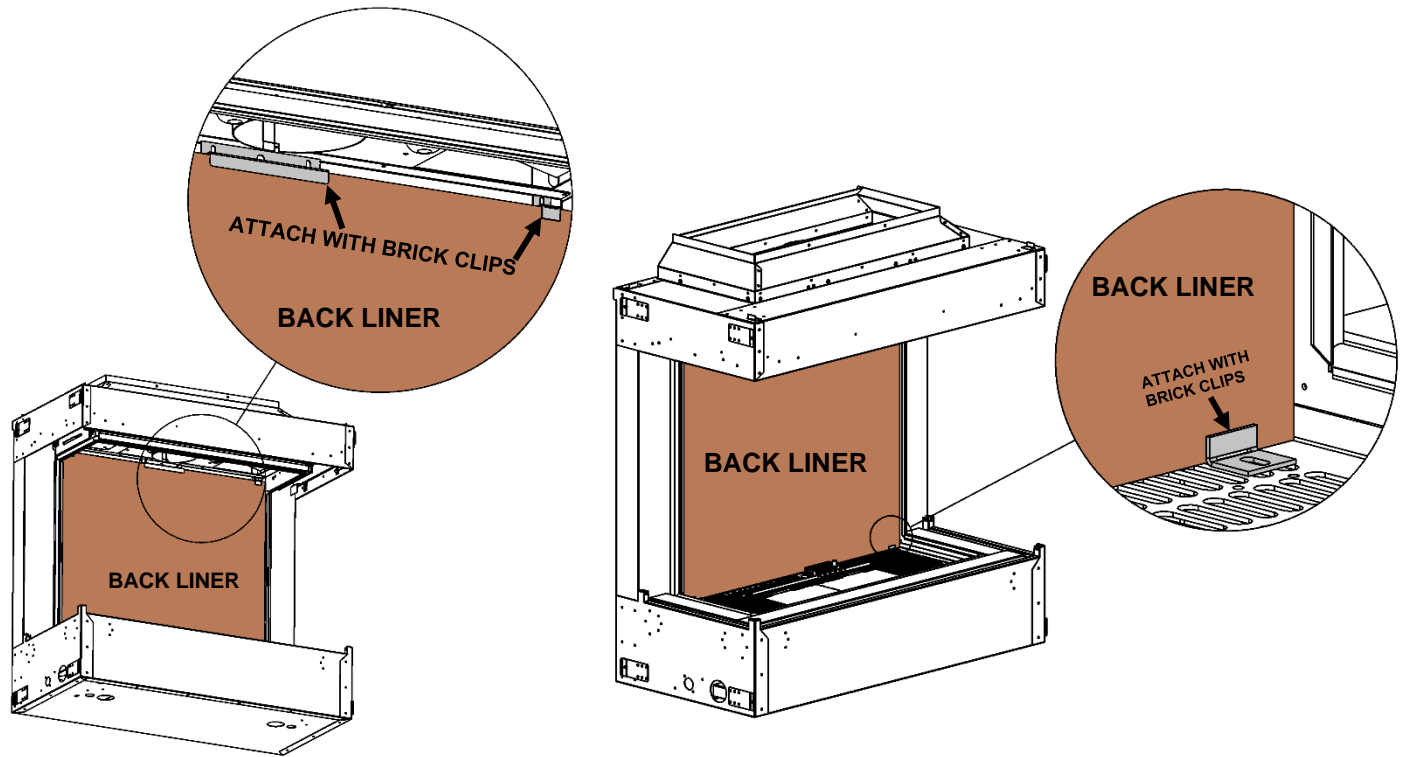

⚠ Note: Discoloration of Liners Is Not Covered Under Warranty.

Liners may discolor during normal operation of your appliance. This is normal, and not considered a defect.

MQZCVBG34 Refractory Side Liner Installation

Option

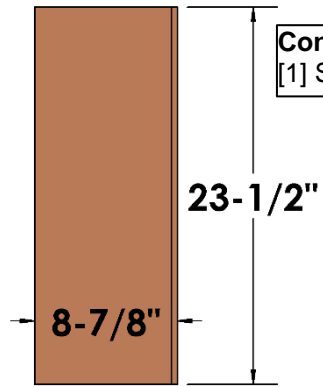

Contents of Kit:
[1] Side Liner

NOTE: ZCVBGCK Corner Kit required. Back Liner must be installed first.
NOTE: If using **CORNER KIT** and you are **NOT** installing a Side Liner, install Inner Liner Panel from Corner Kit before Back Liner. However, if you **ARE** installing a Side Liner, do not install Inner Liner Panel from the Corner Kit.

STEP ONE: Remove Brick Clips from upper side of firebox and bend into shape.

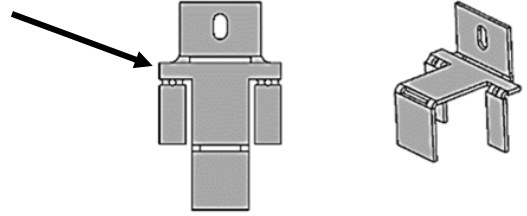

STEP TWO: Insert Side Liner into firebox.

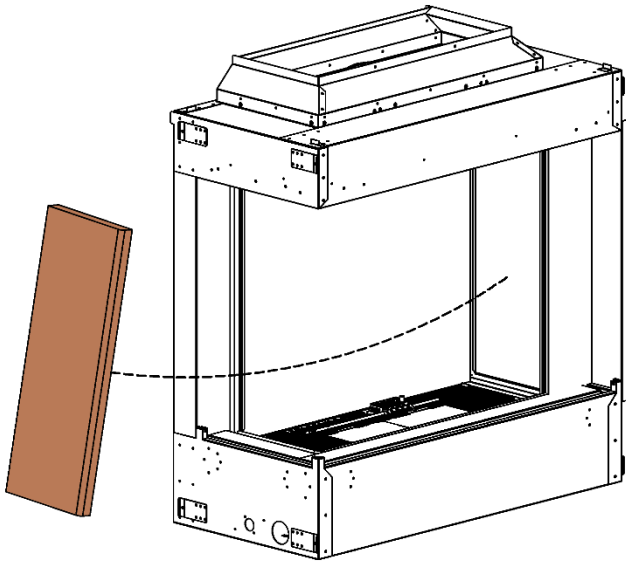

STEP THREE: Set Side Liner in position against side wall of firebox.

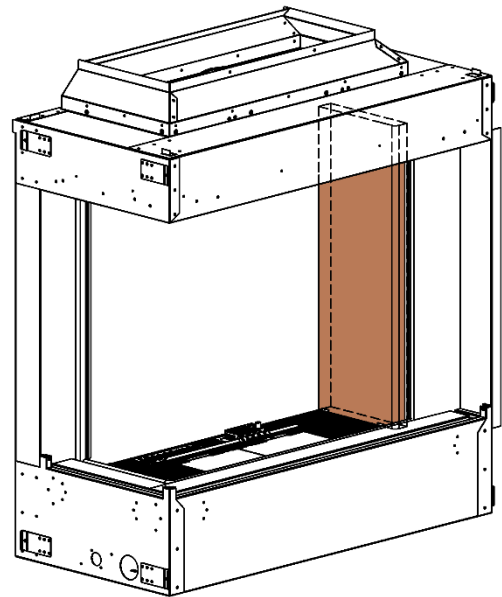

STEP FOUR: Attach top and bottom of Side Liner with Brick Clips as shown below.

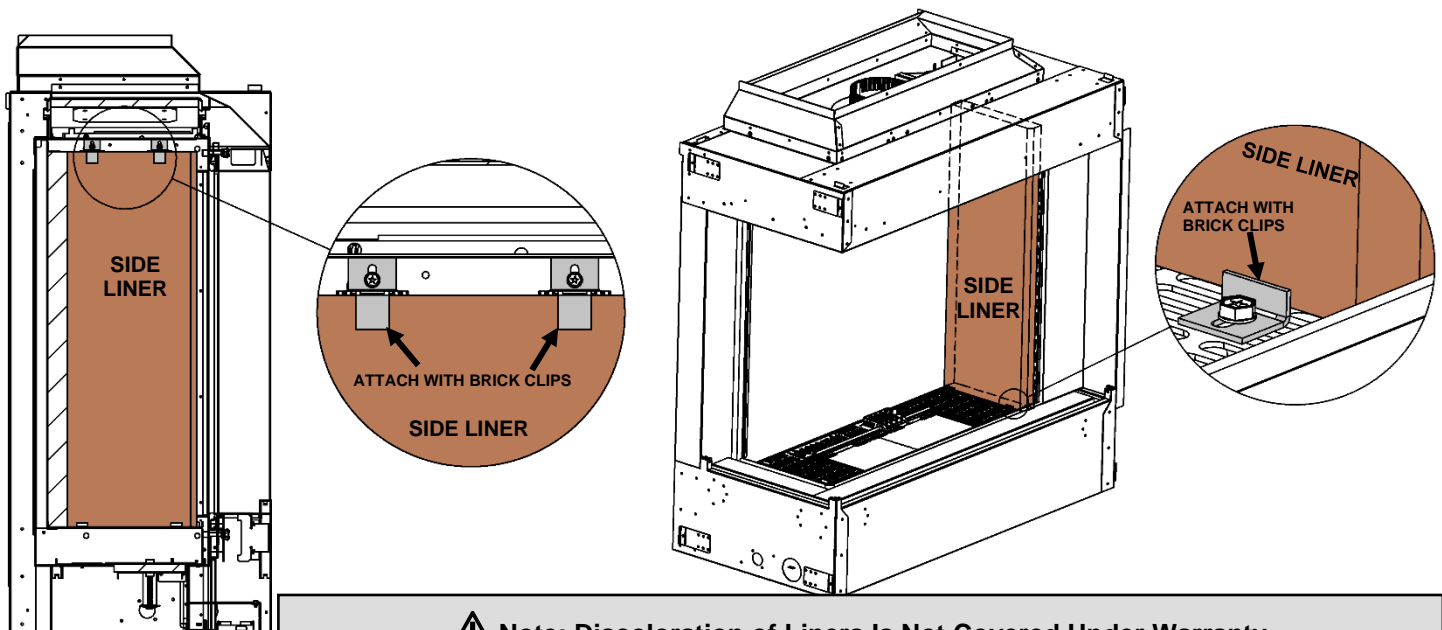

⚠ Note: Discoloration of Liners Is Not Covered Under Warranty.

Liners may discolor during normal operation of your appliance. This is normal, and not considered a defect.

MQZCVBG34 Crushed Glass and Media Options - MQ Dealers Only -

MQZCVBG34 requires [Qty 1] 5LB bag of crushed glass. All glass is sold in 5 LB bags (Maximum 5LB of Glass).

| GLASS SKU | DESCRIPTION |
|-----------|--------------------------------------|
| MQG5W | Decorative Glass 1/2" White |
| MQG5A | Decorative Ember Glass Cobalt Blue |
| MQG5B | Decorative Ember Glass - Black |
| MQG5ZG | Decorative Glass- Zircon Glacier Ice |
| MQG5C | Decorative Glass- Bronze |

The following types of glass are approved:

- Kingsman Decorative Glass
- 1/2" Ember Glass Material from American Fireglass.

GLASS (MQG5W, MQG5A, MQG5B, MQG5ZG, MQG5C)
 If you wish to use this media evenly spread the glass embers onto the false bottom and burner. Ensure the glass embers do not excessively overlap as this will affect the flame pattern. Use care when placing glass embers near the pilot area so as not block or have the glass fall over the crossover holes from the pilot to the burner, as delayed ignition can occur.

Use of any other glass can alter the performance of the unit and is not covered under warranty. Discoloration of glass media may occur if placed on the burner, this is not covered under warranty.

⚠ WARNING

- Pilot Area Must Not Be Covered, as delayed ignition can occur.
- Do not change or substitute the glass ember material provided with this fireplace. If replacing, use only replacement glass embers available from your local authorized dealer.



**Z5GC KINGSMAN
DECORATIVE BRONZE GLASS**



Decorative Glass

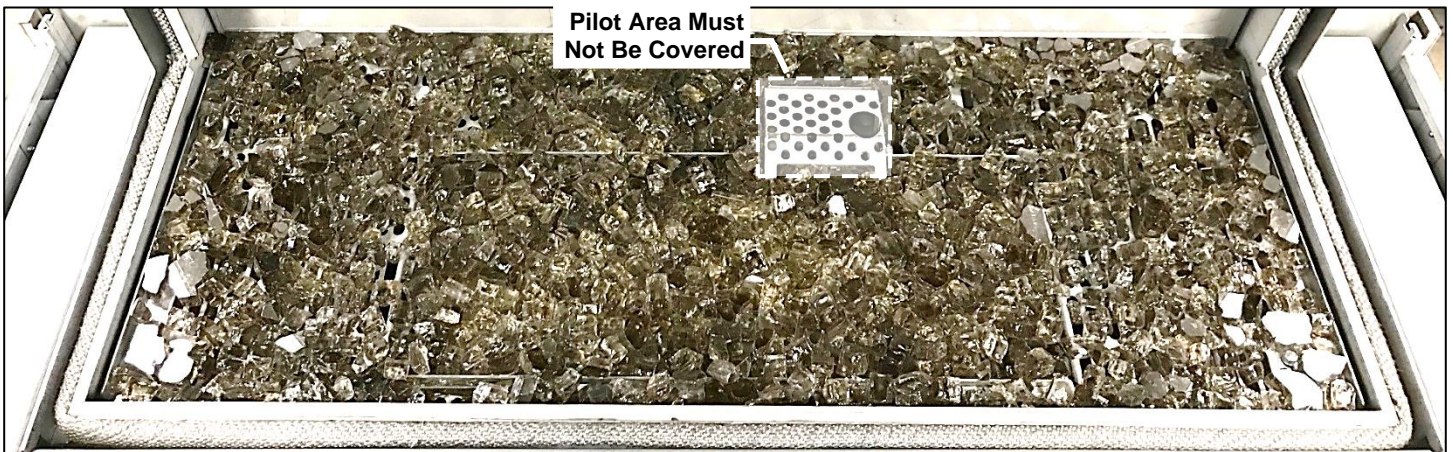

⚠ NOTE

- Pilot Area Must Not Be Covered, as delayed ignition can occur.

MQZCVBG34 - Marquis Collection - Options

MQROCK2, MQROCK3



- **Lava Rock** is supplied with Base Unit. Do not place directly onto Burner.
- Place rocks randomly onto False Bottom and Burner. Do not place directly on burner ports.
- Not all rocks will be used on some installations.
- If sooting occurs change position of or remove affected objects.
- **MQ EMBER** can be placed on Burner.
- **MQ Glass** can be placed on Burner and Glass Tray.



NOTE

Pilot Area Must Not Be Covered, as delayed ignition can occur.

MQ STONE DECORATIVE STONE SET

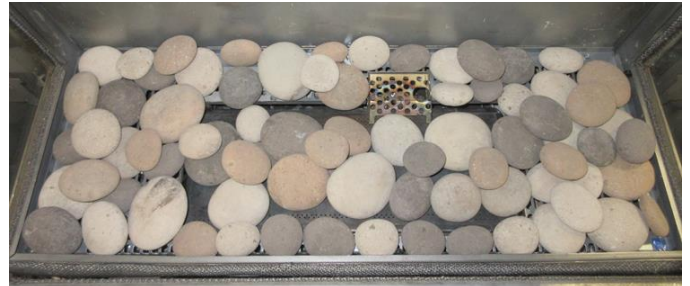

- MQ Stone can be placed on or around Burner.
- **Lava Rock** is supplied with Base Unit. Do not place directly onto Burner.
- Place Stones onto False Bottom and Burner. Do not place directly on burner ports or Pilot Area.
- Not all stones will be used on some installations.
- If sooting occurs change position of or remove affected objects.
- **MQ EMBER** can be placed on Burner.
- **MQ Glass** can be placed on Burner and Glass Tray.

• MQEMBER-

- To be placed directly on Burner and Burner Ports.
- Place these glowing ember chunks randomly. May be used with or without other accessories.

Assorted size and colors. Place randomly as desired inside fireplace.

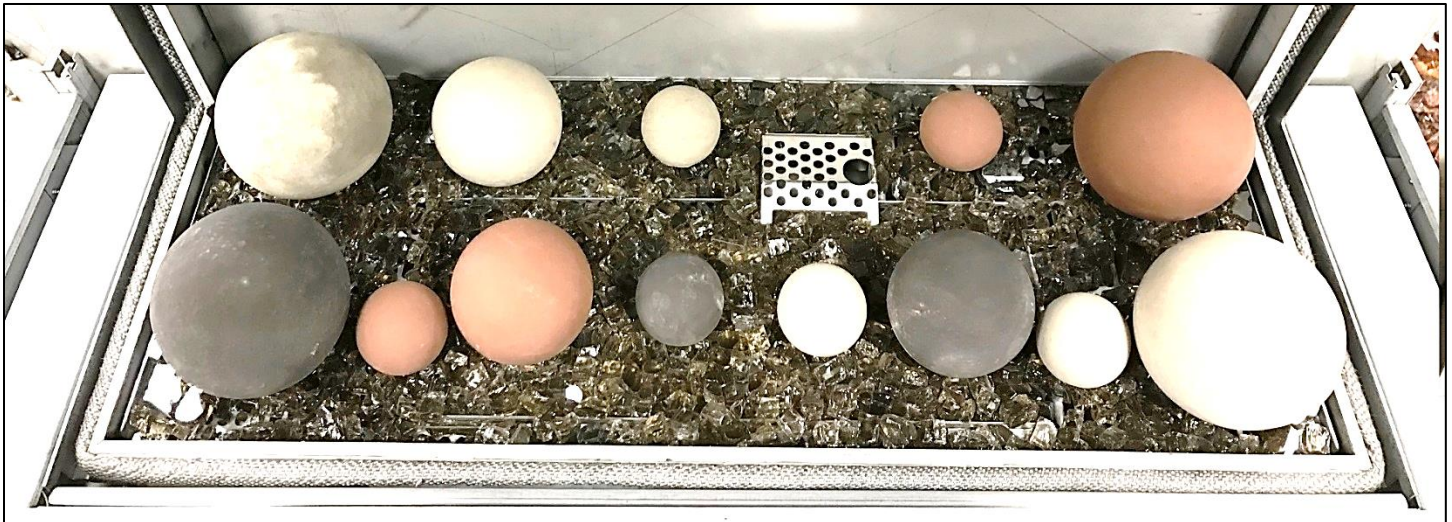

Can be used with MQ Glass, MQ Ember, and / or Lava Rock. Do not place Cannonballs directly on burner ports. If sooting occurs change position of or remove affected objects.

- MQ Glass can be placed directly on Burner and on Glass Tray (Maximum 5 LBS of Glass).
- MQ Ember can be placed directly on Burner Only.
- Lava Rock (Supplied with Base Unit) CANNOT be placed on Burner. Place Lava Rock in channel in front of Glass Tray & on Glass Tray.

 NOTE

- Pilot Area Must Not Be Covered, as delayed ignition can occur.
- Do not place Cannonballs directly on burner ports.

Pilot Area Must Not Be Covered

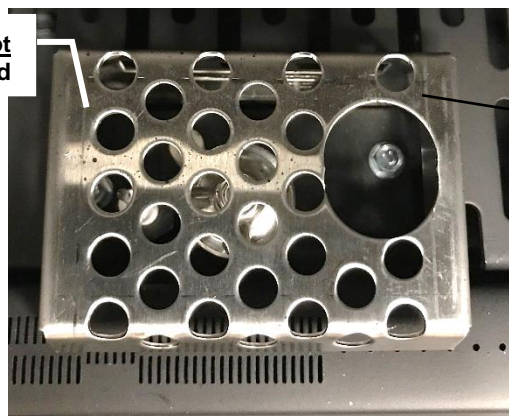

*Pilot Shield should be visually inspected monthly for signs of deterioration due to flame exposure. Replace if necessary.

⚠WARNING: Failure to position the parts in accordance with these diagrams or failure to use only parts specifically approved with this appliance may result in property damage or personal injury.

NOTE: Lava Rock and 350 Embers supplied with fireplace.

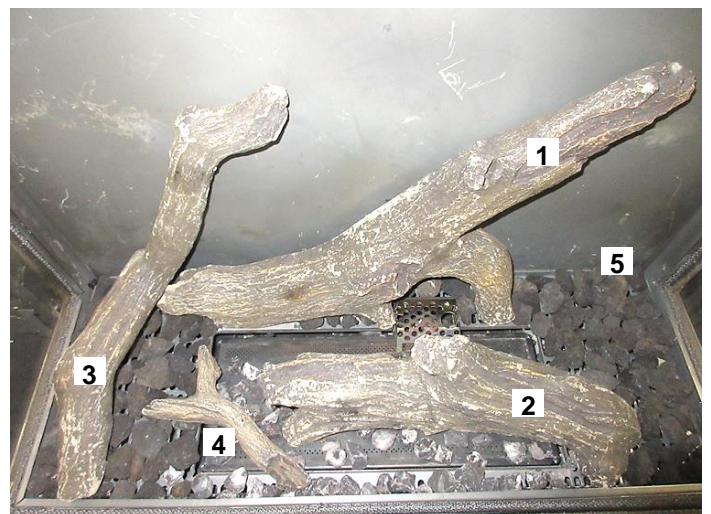
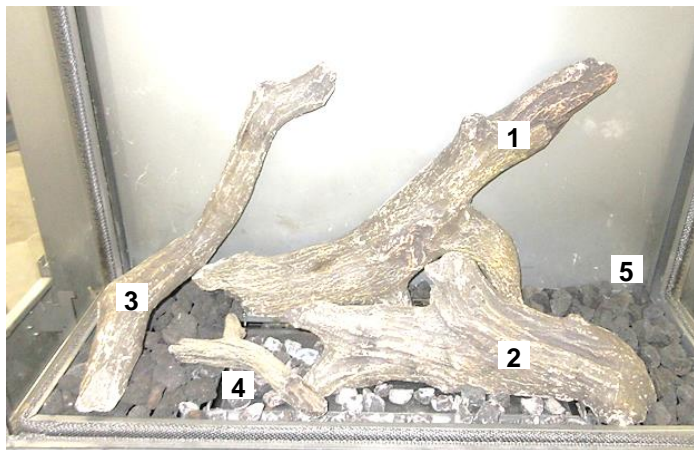

MQZCVBG34 MQRBD3 -5 Piece Driftwood Log Set-

MQ Option

Can be used with MQ Glass, MQ Rock, MQ Stone or MQ Ember. Follow instructions for these accessories.



⚠ NOTE

- For best flame pattern it is essential to spread supplied Crushed Glass or MQEMBER directly onto burner tube.
- If sooting occurs, one or more logs may be removed.





⚠ NOTE

- Pilot area must not be covered, as delayed ignition could occur
- For best flame pattern it is essential to spread supplied Crushed Glass or MQEMBER directly onto burner tube.
- If sooting occurs, one or more logs may be moved.

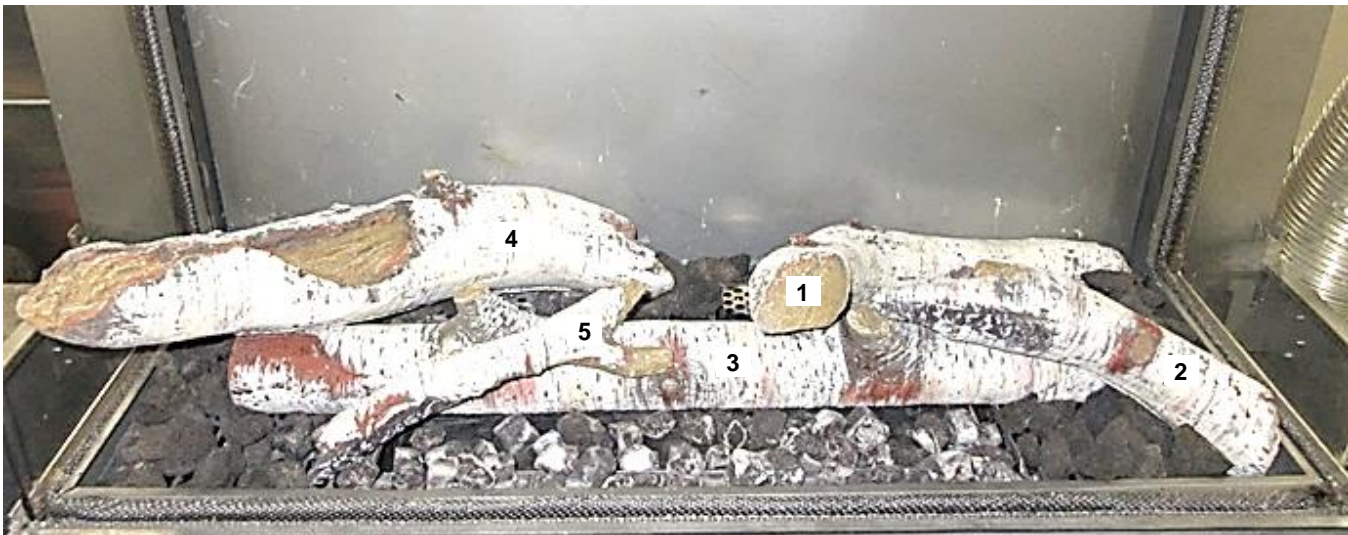



*NOTE: THESE ITEMS ARE SUPPLIED WITH THE FIREPLACE:

*Insulation Wool



*Embers



*Lava Rock



LOG 6 can be replaced with LOG 2 if desired. However, one of these logs must be omitted from the setup.

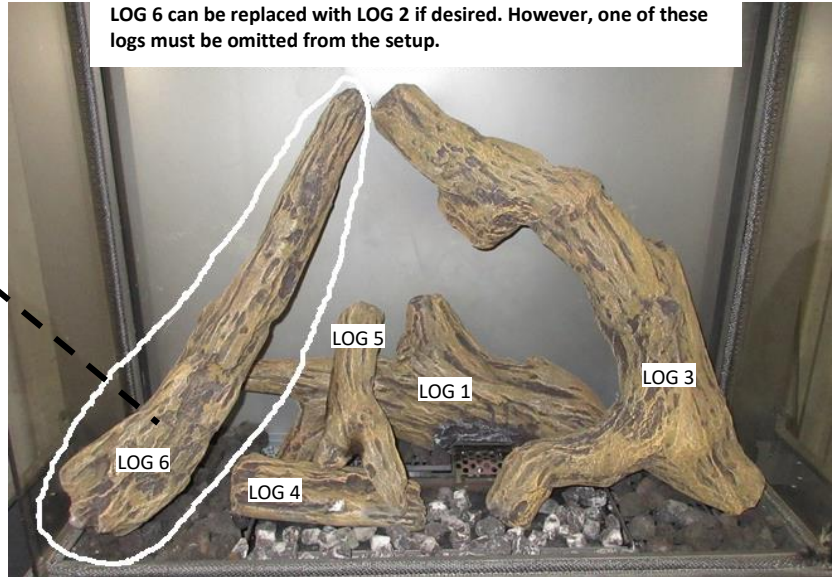

⚠ WARNING:

Failure to position the parts in accordance with these diagrams or failure to use only parts specifically approved with this appliance may result in property damage or personal injury

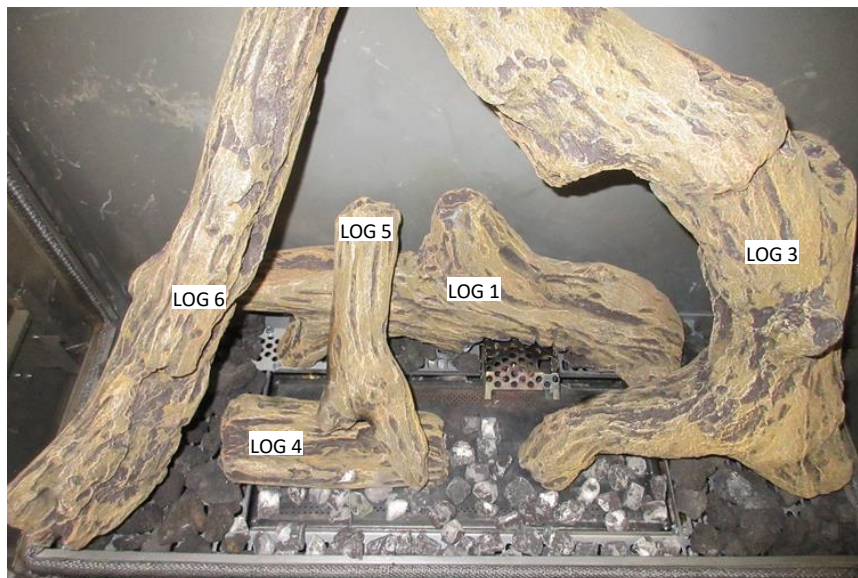

MQLOGF34BW Birchwood Log Set

MQ Option

⚠ NOTE: For best flame pattern it is essential to spread supplied Crushed Glass or MQEMBER directly onto burner tube. If sooting occurs, one or more logs may be removed.

⚠ WARNING: Failure to position the parts in accordance with these diagrams or failure to use only parts specifically approved with this appliance may result in property damage or personal injury.

Refer to MQLOGF34BW & MQLOGF34OAK Setup Instructions.



***NOTE: THESE ITEMS ARE SUPPLIED WITH THE FIREPLACE:**

*Insulation Wool



*Embers



*Lava Rock



⚠ NOTE: For best flame pattern it is essential to spread supplied Crushed Glass or MQEMBER directly onto burner tube. If sooting occurs, one or more logs may be removed.

⚠ WARNING: Failure to position the parts in accordance with these diagrams or failure to use only parts specifically approved with this appliance may result in property damage or personal injury.

Refer to MQLOGF34BW & MQLOGF34OAK Setup Instructions.



***NOTE: THESE ITEMS ARE SUPPLIED WITH THE FIREPLACE:**

*Insulation Wool



*Embers



*Lava Rock



MQLOGF34BW & MQLOGF34OAK Setup Instructions

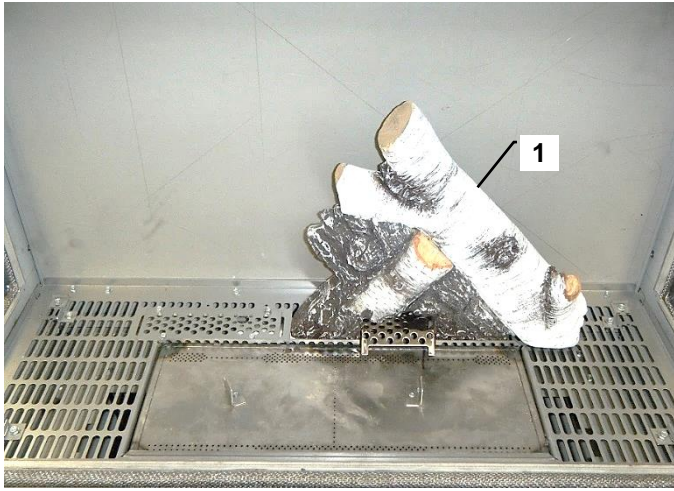

Pull up Log Tabs for Log 3



Set Log 3 onto Tabs on Burner



Place Embers and Insulation Wool on Burner

Place Lava Rock beside burner



This gas appliance should be installed by a qualified installer in accordance with local building codes and with current CAN/CGA - B149.1 or .2 installation codes for Gas Burning appliances and equipment in Canada and the National Fuel Gas Code ANSI Z223 in the U.S.A.

1. The gas pipeline can be brought in through either the right or the left side of the appliance. A knockout is provided at either location to allow for the gas pipe installation and testing of any gas connection.
2. The gas control inlet is 3/8" NPT. Typical installation layout for rigid pipe is shown at right.
3. When using copper or flex connector, use only approved fittings. Always provide a union so that gas line can be easily disconnected for burner or fan servicing. See gas specification for pressure details and ratings.
4. When a vertical section of gas pipe is required for the installation, a condensation trap is needed. See CAN/CGA-B149.1 or .2 for code details.
5. For natural gas, a minimum of 3/8" iron pipe with gas minimum pressure of 4.5" w.c. must be used for supply from the gas meter. Consult with the local gas utility if any questions arise concerning pipe sizes.
6. A 1/8" NPT plugged tappings are accessible for test gauge connection both on the inlet and outlet of the gas valve.
7. Turn the gas supply ON and check for leaks. **DO NOT USE OPEN FLAME FOR THIS PURPOSE.** Use an approved leak testing solution.
8. The appliance and its individual shutoff valve must be disconnected from the gas supply piping system during any pressure testing of that system at test pressures in excess of 1/2 PSIG (3.5 KPa).
9. The appliance must be isolated from the gas supply piping system by closing its individual shutoff valve during any pressure testing of the gas supply piping system at test pressures equal to or less than 1/2 PSIG (3.5 KPa).

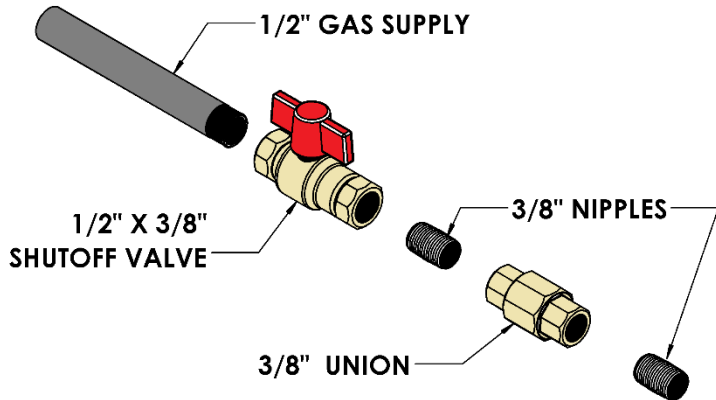

NOTE: The gas line connection may be made of 1/2" rigid pipe or an **Approved Kingsman Flex Connector, such as FP15GC.** Since some municipalities have additional local codes, it is always best to consult your local authorities and the current CAN/CGA - B149.1 or .2 installation code in Canada or the National Fuel Gas code ANSI Z223.1 in the U.S.A

For the state of Massachusetts a T-handle gas shut-off valve must be used on a gas appliance. This T-handle gas shut-off valve must be listed and approved by the state of Massachusetts. This is in reference to the state of Massachusetts state code CMR238.

Important: Always check for gas leaks with a soap and water solution. Do not use open flame for leak testing.

Shutoff valves installed in tubing systems shall be rigidly and securely supported independently of the tubing.

Gas Specifications

| MODELS | MQZCVBG34NE2 | MQZCVBG34LPE2 | |
|--|-----------------------|---------------|-----------------------|
| Fuel | Natural | Propane | |
| Gas Control | IPI | IPI | |
| INPUT | | | |
| Maximum | 25,000 BTU | 24,000 BTU | |
| Low | 17,500 BTU | 19,000 BTU | |
| Orifice Size (0-4500ft) | # 39 | # 51 | |
| Air Shutter | 1/8" | Fully Open | |
| Gas Inlet Size S.I.T. 820 Nova, 3/8" NPT | | | |
| Gas Supply Pressure | Minimum | Normal | Maximum |
| Natural Gas | 5.5" | 7" | 9" |
| Propane | 11" | 11" | 12" |
| Manifold Pressure | Natural Gas | | Propane |
| Manifold Pressure High | 3.5 IN. W.C./1.87 KPa | | 10 IN. W.C./2.61 KPa |
| Manifold Pressure Low | 1.6 IN. W.C./1.40 KPa | | 6.3 IN. W.C./1.57 KPa |

Annual Inspection List for Determining Safe Operation of a Direct Vent Gas Fireplace

Refer to this checklist for proper maintenance, safe use, and operation.

See each section for more specific information.

1. Inspect and operate all pressure relief mechanisms (i.e., relief dampers, spring loaded door latches) installed on your appliance to verify relief mechanisms are free from obstruction to operate.

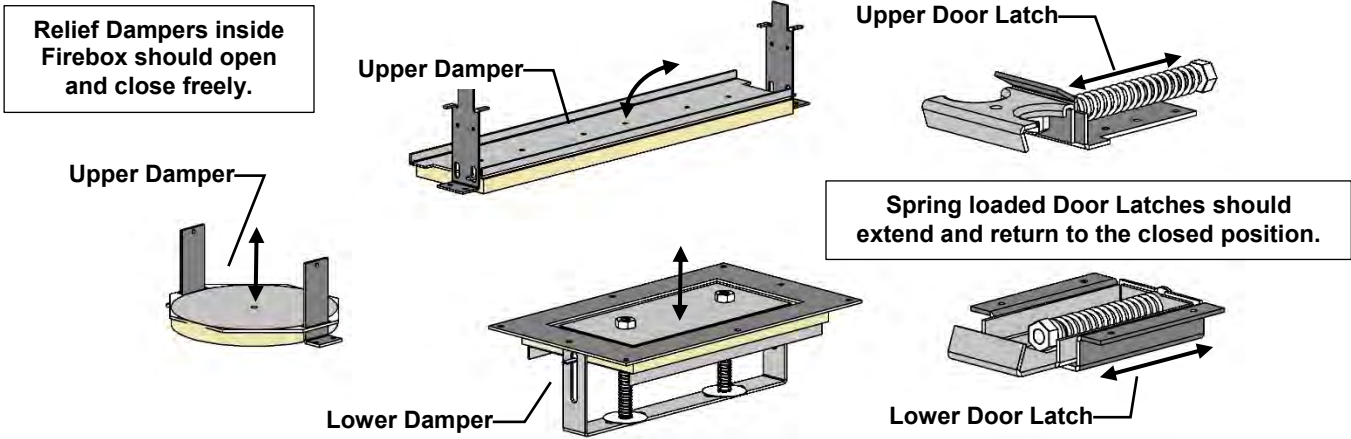

2. Clean glass window with a suitable fireplace glass cleaner. Abrasive cleaners must not be used. Be careful not to scratch the glass when cleaning.

3. Inspect the operation of the Pilot. Ensure that it is working properly.

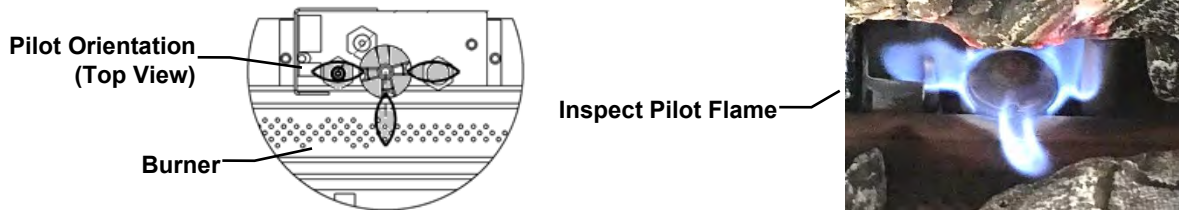

4. Inspect and ensure the lighting of the main burner occurs within 4 seconds of the main gas valve opening. Visual inspection should match that outlined in the appliance instruction manual (refer to **Monthly Flame Inspection**). Inspect primary air openings for blockage.

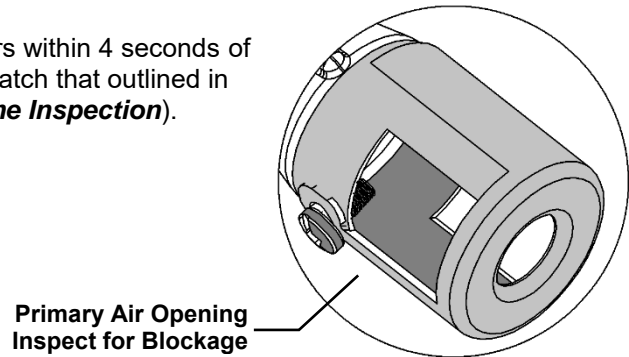

5. Inspect condition of vent and vent terminal for sooting or obstruction and correct if present.
6. Vacuum and clean any debris in the firebox that is not supposed to be there.
7. Test and measure the flame failure response time of the flame safety system. It must de-energize the safety shutoff in no more than 30 seconds.

Procedure for Millivolt Units: Turn on fireplace for 5 minutes. Shut off fireplace while listening to valve. A "click" should be heard within 30 seconds. This indicates the safety shutoff is working properly.

Procedure for IPI Units: Turn on fireplace and allow main burner to come on. Then disconnect Flame Sense wire from IPI Module (X3 Connection). The fireplace should shut down immediately.
8. Check all accessible gas-carrying tubes, connections, pipes and other components for leaks.

Troubleshooting the Gas Control System

⚠ WARNING

BEFORE DOING ANY GAS CONTROL SERVICE WORK, REMOVE THE GLASS FRONT.

NOTE: Before troubleshooting the gas control system, be sure external gas shut off is in the "On" position.

| Problem | Possible Causes | Corrective Action |
|---|--|--|
| Spark igniter will not light. | Defective or misaligned electrode at pilot. | Check for spark at electrode and pilot: if no spark and electrode wire is properly connected, replace igniter. |
| | Defective igniter (push-button). | Using a match, light pilot. If pilot lights, turn off pilot and push the red button again. If pilot will not light - check gap at electrode and pilot should be 1/8" to 1/4" to have a strong spark. |
| Pilot will not stay lit after carefully following lighting instructions. | Defective thermocouple (flame switch where applicable). | Check pilot flame. Must impinge on generator and thermocouple. Clean and/or adjust pilot for maximum flame impingement on generator and thermocouple. Replace thermocouple if pilot will not hold. (Hand tight 1/8 turn on replacement) |
| | Defective valve magnet. | Replace valve, if pilot won't hold after the thermocouple is replaced. |
| Pilot burning, no gas to burner, valve knob "ON", and wall switch "ON". | Wall switch or wires defective. | Check wall switch and wires for proper connections. Jumper wire across terminals at wall switch. If burner comes on, replace defective wall switch. If okay, jumper wires, across wall switch wires at valve. If burner comes on, wires are faulty or connections are bad. |
| | Generator may not be generating sufficient voltage. | Check generator with millivolt meter. Take reading at generator terminals of gas valve. Should read 325 millivolts minimum while holding valve knob depressed in pilot position and wall switch "off" Replace faulty generator if reading is below specified minimum. |
| | Plugged burner orifice. | Check burner orifice for stoppage and remove. |
| | Defective automatic valve operator. | Remove wall switch wires from gas valve. Install jumper wires from top bottom terminals of gas valve. Turn valve on "ON". If main burner does not light, replace valve. |
| Frequent pilot outage problem. | Pilot flame may be too low or blowing (high) causing the pilot safety to drop out. | Clean and/or adjust pilot flame for maximum flame impingement on generator and thermocouple. *See NOTE below – Seven Day Timer |
| Flame lifts off burner and goes out in less than 30 seconds. | Inner 4" liner has come off flue or termination, flame is starving for oxygen. | Attach 4" liner to flue or termination using screws, silicone and clamps as stated in manual. |
| Flame lifts off burner on one side while the rest of the flame remains lit. | Improper installation of firebrick. Firebrick is likely leaning. | Be sure to position firebrick against firebox walls and be sure to use brick clips attached to the inner side of firebox. |

***NOTE:** The pilot system for this appliance may be equipped with a **Seven Day Timer**, in which case the pilot flame will be extinguished if the main burner has not been turned ON for seven days.

This Seven Day Cycle is reset every time the main burner is cycled ON / OFF and the pilot remains lit.

If more than seven days has passed since the main burner has been cycled ON / OFF and the pilot is also out, follow the procedures described in this manual to light the pilot.

NOTE: MILLIVOLT UNITS WITH 7 DAY TIMER – When lighting pilot, the Pilot Knob must be pressed until a **BEEP** is heard. This procedure may take up to **TWO MINUTES**.

It is recommended to annually inspect and clean the Burner System to prevent malfunction and / or sooting. This operation should be performed by your dealer or a qualified technician.

⚠ -CAUTION-

Before servicing the burner system ensure that the gas supply is turned OFF and disconnect all electrical connections to the appliance. Allow the appliance to cool to room temperature. Note that the pilot assembly may be hot in an intermittent or standing-pilot system—even if the main burner was never on. Exercise caution when working within the area.

-ALL WORK SHOULD BE PERFORMED BY A QUALIFIED AND CERTIFIED TECHNICIAN-

Monthly Flame Inspection



It is recommended to turn on the unit at least once a month and inspect the flame pattern to ensure there are no problems with the burner tube (Flame should appear similar to the above picture).

The pilot flame should also be inspected monthly to ensure proper operation.



Pilot Must Maintain This Relationship With Burner.

*Pilot Shield should be visually inspected monthly for signs of deterioration due to flame exposure. Replace if necessary.



Pilot Area Must Not Be Covered.

MQZCVBG34

-Gas Conversion Part A-

Models: MQZCVBG34NE2, MQZCVBG34LPE2

| Kit Number | Description | Pilot Orifice | Burner Orifice Brass (1000-255) | Brass Nipple | Air Shutter | Hi/Lo Regulator |
|---------------|-----------------------------|------------------------------|------------------------------------|----------------|-------------|--------------------------|
| 34ZCVBG-CKLP2 | Propane Conversion -IPI- | 1001-P168SI #35 (977.168) | #51 | 1000-253 Close | Fully Open | 1002-P012SI (907.012) |
| 34ZCVBG-CKNG2 | NG Conversion -IPI- | 1001-P166SI #62 (977.166) | #39 | 1000-253 Close | 1/8" | 1002-P013SI (907.013) |

IMPORTANT: Always check for gas leaks with a soap and water solution. DO NOT USE OPEN FLAME FOR LEAK TESTING.

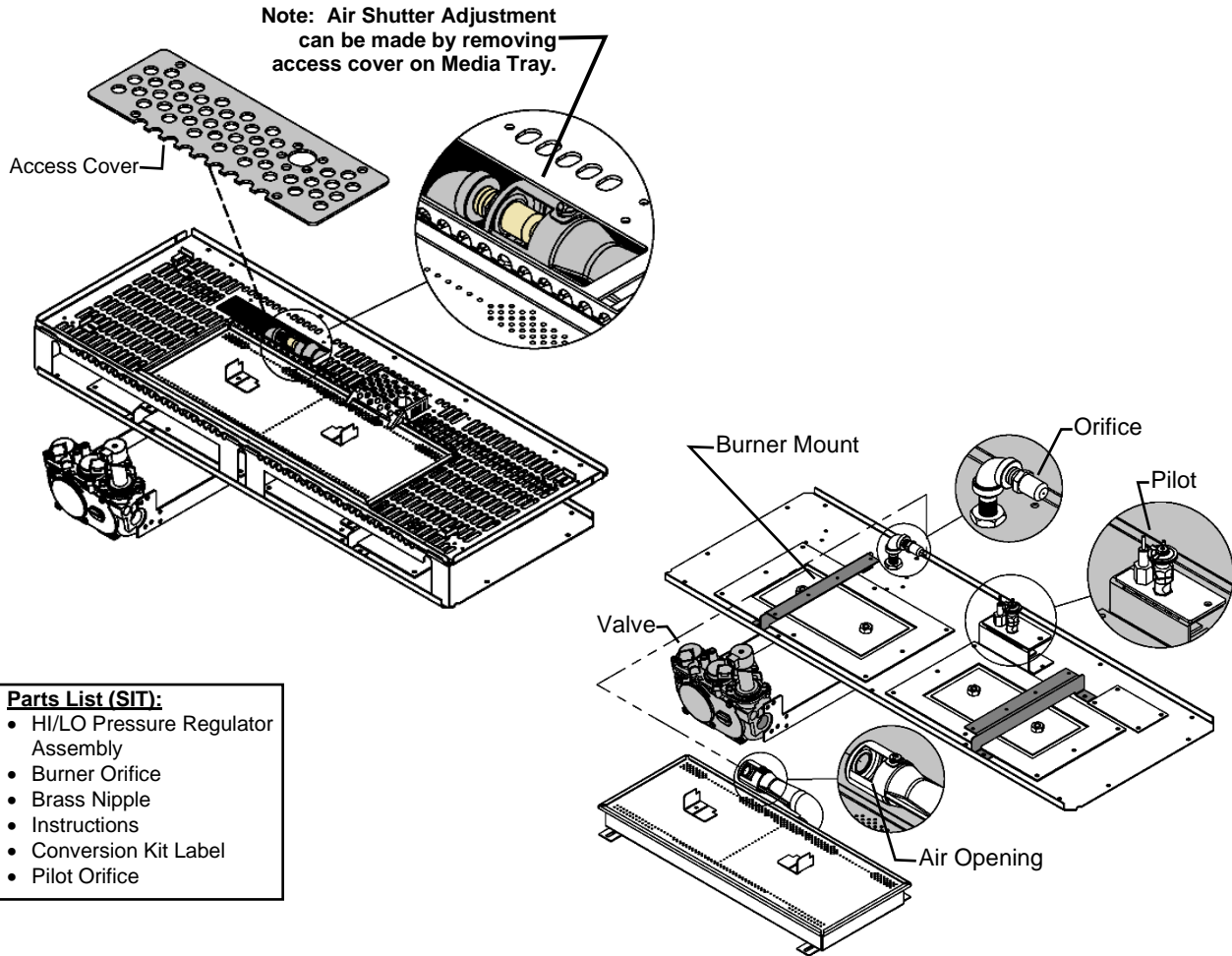

⚠ Caution:

The gas supply shall be shut off prior to disconnecting the electrical power, before proceeding with the conversion.

1. The Burner Tube must be removed from the Burner Pan Assembly (See **Burner Tube Removal**). Adjust the Air Shutter to the correct Primary Air setting as specified in the manual or on the label plate. To adjust the Primary Air setting, loosen screw on the side of the Air Shutter and rotate to the correct opening using a drill bit or tape measure. Retighten screw.
 2. Remove the Main Orifice using a 1/2" wrench and replace with the new Conversion Orifice which came with the Conversion Kit.
 3. Replace the Burner Tube. Install the new Pilot Orifice (See **Pilot Conversion**) and Hi/Lo valve regulator by following instructions supplied with the Conversion Kit.
- Refer to **Gas Specifications Chart** for inlet pressures and input ratings.
 - Clock meter to verify input rate.
 - Place conversion label as close to converted gas control as possible.
 - Refer to **lighting instructions** to verify the normal operating sequence of the ignition system.
 - Refer to **Burner System Maintenance** for proper relationship of the pilot flame to the main burner and for main burner flame appearance.

⚠ Warning

This conversion kit shall be installed by a qualified service agency in accordance with the manufacturer's instructions and all applicable codes and requirements of the authority having jurisdiction. If the information in these instructions is not followed exactly, a fire, explosion or production of carbon monoxide may result causing property damage, personal injury or loss of life. The qualified service agency is responsible for the proper installation of this kit. The installation is not proper and complete until the operation of the converted appliance is checked as specified in the manufacturer's instructions supplied with the kit.



Instructions for converting SIT 190 series pilot burner injector from NG to PROPANE and from PROPANE to NG only. This information should be considered as supplemental to the Appliance Manufacturer's Instructions.

WARNING! The installation of this conversion kit must only be undertaken by a qualified and certified gas appliance installer.

1. Shut-off the gas supply to the appliance.
2. Allow the pilot burner to cool to room temperature.

WARNING: Touching a hot pilot burner can result in injury.

3. The pilot hood is held in place by spring. First remove the spring, then remove the hood by pulling it up from the pilot bracket (fig. 1).
4. Insert a 5/32" or 4 mm Allen wrench into the hexagonal key-way of the injector (fig. 2), and rotate it counter-clockwise until it is free of the injector journal.
5. Verify that the new injector is proper for the application. The injector size is stamped on the side of the injector near the top. Propane injectors have a groove machined around their circumference near the top, while NG injectors do not have a groove (fig. 4). Refer to the Appliance Manufacturer's instruction sheet for the proper injector size.
6. Insert the Allen wrench into the end of the injector. Then, insert the injector into injector journal, and rotate the injector clockwise until a torque of 9 lbf in (1.0 Nm) is achieved.
7. First replace the pilot hood by aligning the tab on the base of the hood with the slot in the side of the pilot journal, and push the hood down, onto the pilot bracket (fig. 3). The hood must sit squarely on the bracket for proper operation. Then replace the spring by pushing it on his seat (fig.3). Check to insure that the hood is properly seated onto the pilot bracket and that the spring is properly inserted onto his seat.
8. Restore the gas supply to the appliance, and ignite the pilot burner. Verify proper ignition and operation.

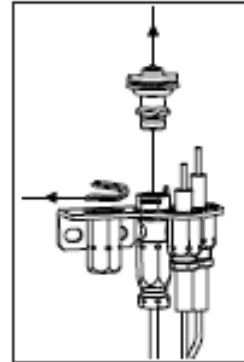

fig. 1

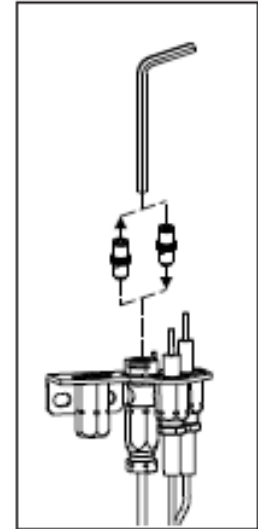

fig. 2

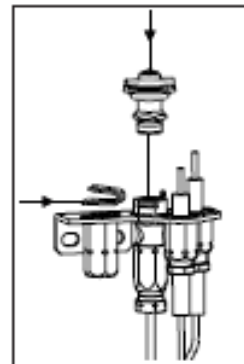

fig. 3

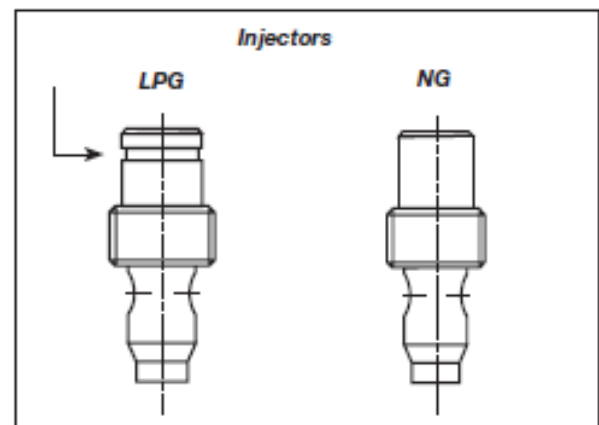

fig. 4

WARNING!

This conversion kit must **ONLY** be applied as part of a conversion kit supplied by the **APPLIANCE MANUFACTURER** for the specific appliance, and type of gas, being converted.



SIT GROUP

www.sitgroup.it

installation instructions

7.252.136

820 NOVA mV

Modulating Conversion Kit



WARNING!

The installation of this conversion kit must only be undertaken by a qualified and certified gas appliance installer.

MODULATING PRESSURE REGULATOR CONVERSION KIT INSTALLATION OR REPLACEMENT INSTRUCTIONS.

- 1 Turn control knob to the OFF position, and shut off the gas supply to the valve.
- 2 Using a Torx T20, or slotted screwdriver, remove and discard the three pressure regulator mounting screws (A), pressure regulator tower (B), and the spring and diaphragm assembly (C).
(If applicable)
- 3 Insure that the rubber gasket (D) is properly positioned and install the new modulating pressure regulator assembly to the valve using the new screws (E) supplied with the kit. Tighten screws securely.
(Reference torque = 25 In.Lb.)
- 4 Install the enclosed identification label (F) to the valve body where it can be easily seen.
- 5 Apply gas to system and re-light appliance according to manufacturers instructions.
- 6 With the main burner "ON", test the new pressure regulator assembly for leaks using a soap solution.
- 7 Relight the main burner in both the HI and LO positions, and verify proper burner ignition and operation.

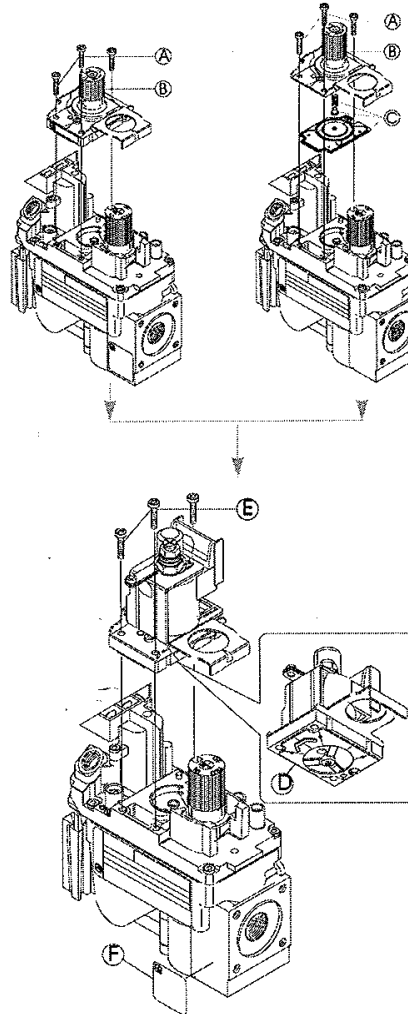

WARNING!

This modulating conversion kit must ONLY be applied as part of a conversion kit supplied by the APPLIANCE MANUFACTURER for the specific appliance, and type of gas, being converted.

INSTALLER NOTICE. These instructions must be left with appliance.



SIT Group

MQZCVBG34

Burner Removal

To remove Burner, remove Media Tray. Remove the [4] DT Screws from Burner. Slide Burner slightly to the right to dislodge it from the Orifice and remove it from the fireplace.

⚠ WARNING

Turn off Unit and allow to cool before cleaning. Only a Qualified service technician should service and repair this appliance.

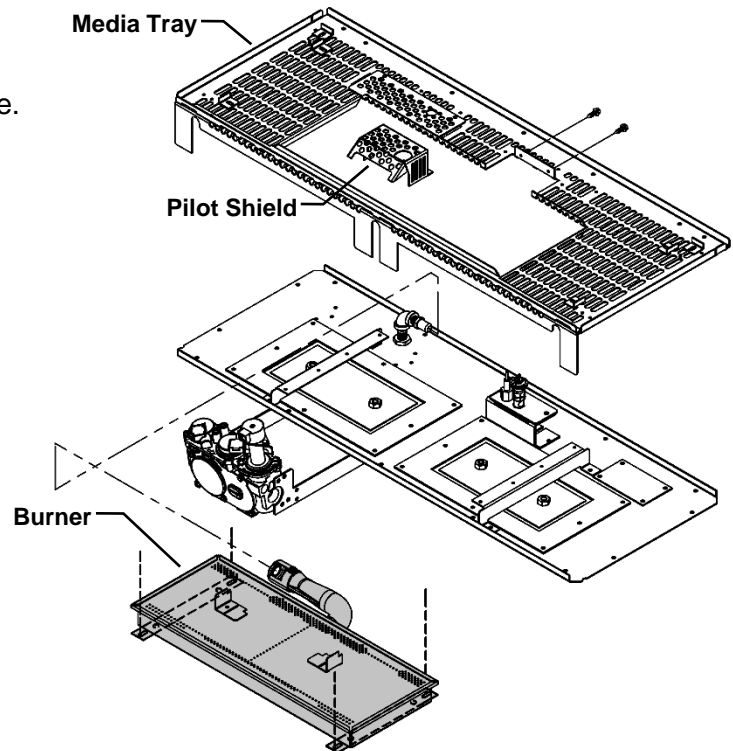

MQZCVBG34

Burner System Removal / Installation

Burner System Removal: Remove Media Tray. Remove DT Screws around perimeter of Burner Pan. Carefully work the burner pan loose & lift the assembly upward to remove it from the firebox cavity. **Burner System Installation** is the reverse of these steps. Ensure that the mounting surface is clean. Use fresh **Black Mill Pac** to reseal the burner pan.



NOTE: Pilot connections through Burner Pan must be sealed with **Red Silicone**.

⚠ WARNING

Turn off Unit and allow to cool before cleaning. Only a Qualified service technician should service and repair this appliance.

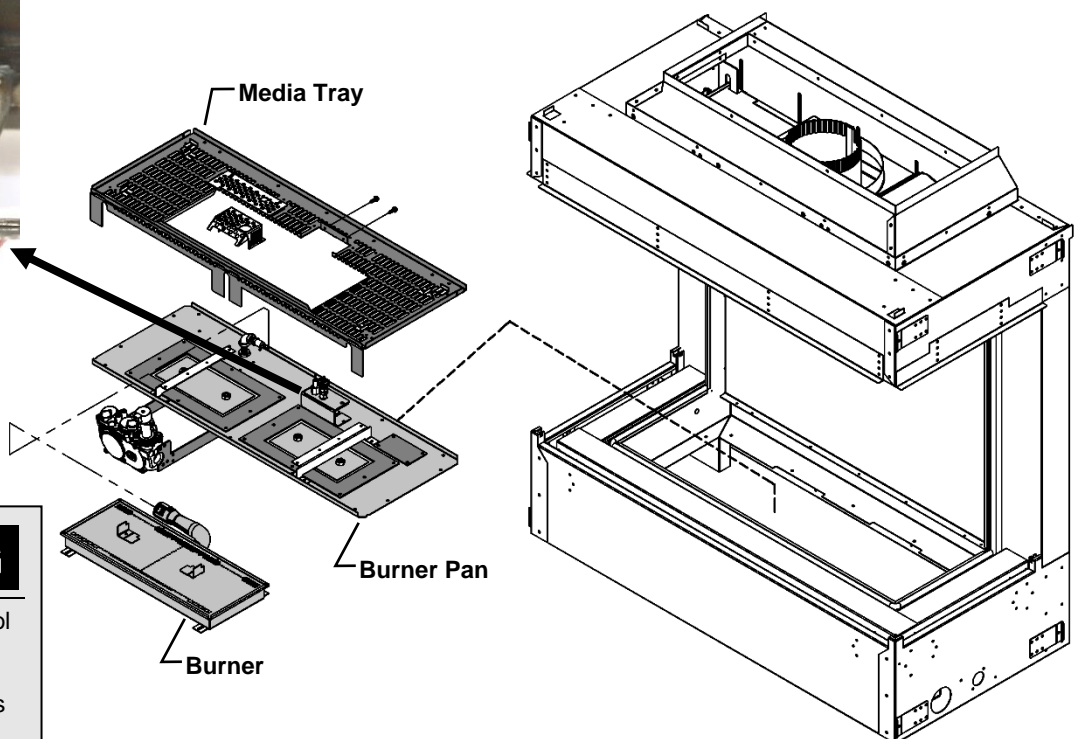

- IPI LIGHTING INSTRUCTIONS - FOR YOUR SAFETY READ BEFORE LIGHTING

WARNING: If you do not follow these instructions exactly, a fire or explosion may result causing property damage, personal injury or loss of life.

- A. This appliance is equipped with an ignition device which automatically lights the pilot. Do not try to light the pilot by hand.
- B. **BEFORE OPERATING** smell around the appliance area for gas. Be sure to smell next to the floor because some gas is heavier than air and will settle on the floor.
- WHAT TO DO IF YOU SMELL GAS
- Do not try to light any appliance.
 - Do not touch any electric switch; do not use any phone in your building.
 - Immediately call your gas supplier from a neighbor's phone. Follow the gas supplier's instructions.
- If you cannot reach your gas supplier, call the fire department.
 - C. Do not use this appliance if any part has been under water. Immediately call a qualified service technician to inspect the appliance and replace any part of the control system and any gas control which has been under water.
 - D. If the gas valve requires repair, call a qualified service technician. Force or attempted repair may result in a fire or explosion.

OPERATING INSTRUCTIONS

1. Stop! Read the safety information above on this label.
2. Read the owner's manual including the section on "Remote Control" operation if applicable.
3. Turn off all electric power to the appliance.
4. This appliance is equipped with an ignition device which automatically lights the pilot. Do not try to light the pilot by hand.
5. Wait five (5) minutes to clear out any gas. Then smell for gas, including near the floor. If you smell gas, STOP! Follow "B" in the safety information above this label. If you do not smell gas, go to next step.
6. Turn on all electric power to the fireplace.
7. Turn "On" Switch that operates the Main Burner. For **Remote Control** units, press the ON/OFF key on the remote control. "ON" will be displayed on the LCD display and a "beep" will be heard at the unit to indicate the command has been received.
8. If the appliance will not operate, follow the instructions "To Turn Off Gas To Appliance" and call your service technician or gas supplier.

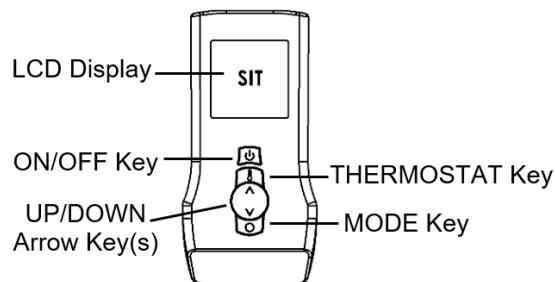

TO TURN OFF GAS TO APPLIANCE

1. Set thermostat to lowest setting. For **Remote Control** units, press the ON/OFF key on the remote control. "OFF" will be displayed on the LCD display and a "beep" will be heard at the unit to indicate the command has been received.
2. Turn off all electric power to the fireplace if service is to be performed.

| IPI PROFLAME 2 - COMPONENT PARTS | | |
|--|-------------|---|
| PART NO. | DESCRIPTION | |
| 1. | 1005-P001SI | Valve IPI Proflame PF2 885.001 NG - Stepper |
| 2. | 1005-P002SI | Valve IPI Proflame PF2 885.002 LP - Stepper |
| 3. | 1005-P325SI | Module IPI - Proflame 2 - 584.325 |
| 4. | 1005-P627SI | Module IPI – Proflame 2 - Basic - 584.627 |
| 5. | 1005-P924SI | Harness PF2 - 584.924 |
| 6. | GTMFL | Transmitter- PF2 - 584.090 - WiFi Version |
| 6b. | 1005-P042SI | Transmitter- PF2 - 584.042 - Non-WiFi Version |
| 6c. | 1005-P080SI | Transmitter- PF2 - 584.080 - WiFi Version |
| For Replacement Transmitters, Replace with Same Part Number | | |
| 7. | 584-PWR-C | Wire Harness PF2 – Power Cord |
| 8. | 584-X4P | Terminal Block |
| 9. | 584-X10 | Wire Harness PF2 |
| 10. | 584-ACC01-C | Wire Harness PF2 - Fan/Light |
| 11. | 584-X8-B | Wire Harness PF2 - Optional Reset Harness |
| 12. | 584-X12 | Optional Power Vent Harness |

| IPI - PF1 and PF2 Common Components | | | |
|-------------------------------------|-------------|--|--------------------------|
| PART NO. | DESCRIPTION | | |
| 13. | 1002-P033SI | TC - Pilot Burner IPI (Assembled) NG 199.033 | |
| 14. | 1002-P047SI | TC - Pilot Burner IPI (Assembled) LP 199.047 | |
| 15. | 1001-P166SI | TC - Orifice Pilot NG 977.166 #62 (IPI) | |
| 16. | 1001-P168SI | TC - Orifice Pilot LP 977.168 #35 (IPI) | |
| 17. | 1001-P280SI | TC - Tubing W/Fittings 1/8 2.182.280 | |
| 18. | 1002-P012SI | IPI Stepper Kit - LP 907.012 | P2 CONVERSION |
| 19. | 1002-P013SI | IPI Stepper Kit - NG 907.013 | |
| 20. | 1002-P014SI | IPI Reg Kit - LP Hi-Lo 907.014 | P1 CONVERSION |
| 21. | 1002-P016SI | IPI Reg Kit - NG Hi-Lo 907.016 | |
| 22. | 1002-P017SI | TC - Electrode Cable & Sparker IPI 915.017 24" | |
| 23. | 1002-P119SI | TC - Electrode Cable & Sparker IPI 35" (Infinite, ZCVRB47, VRB46) | |
| 24. | 1002-P12BH | IPI Battery Housing 12bh347-Gr | |
| 25. | 1002-P903SI | TC - Electrode Flame Sense IPI 007.253/915.903 24" | |
| 26. | 1002-P910SI | TC - Electrode Flame Sense 35" (Infinite, ZCVRB47, VRB46) | |

NOTE: Fan and / or Light Options are not available on some fireplaces. **Check with your dealer.**

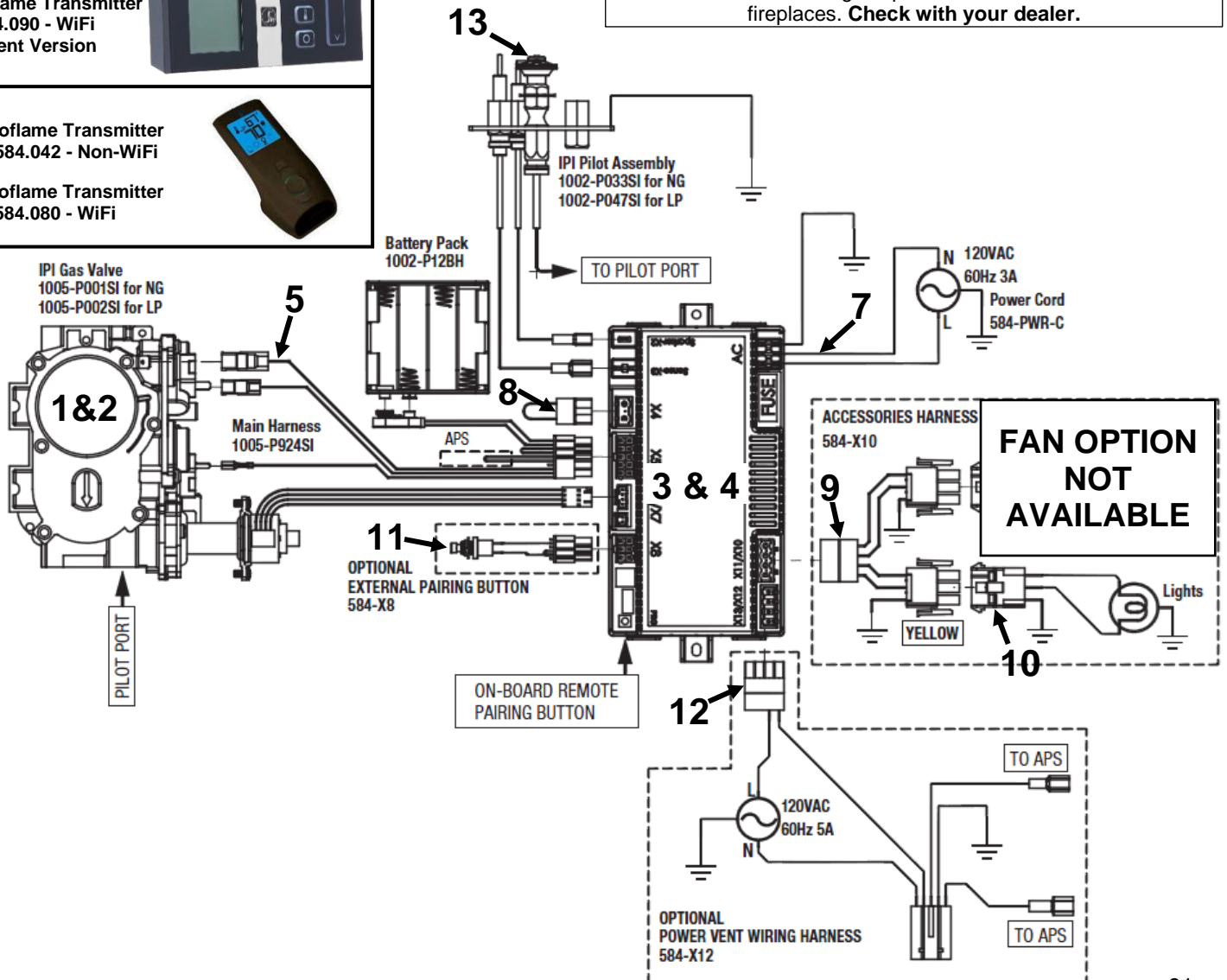
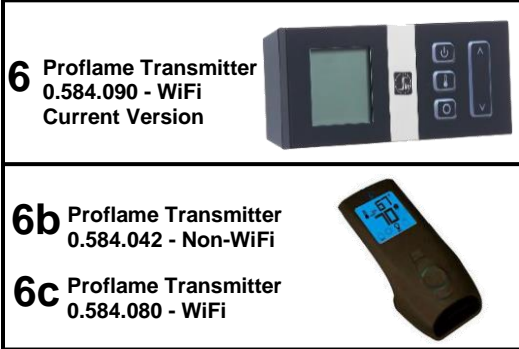

Proflame 2 IPI - IFC Module and Remote Control

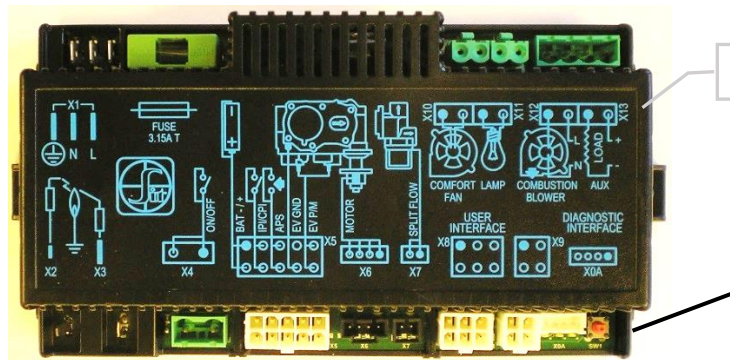
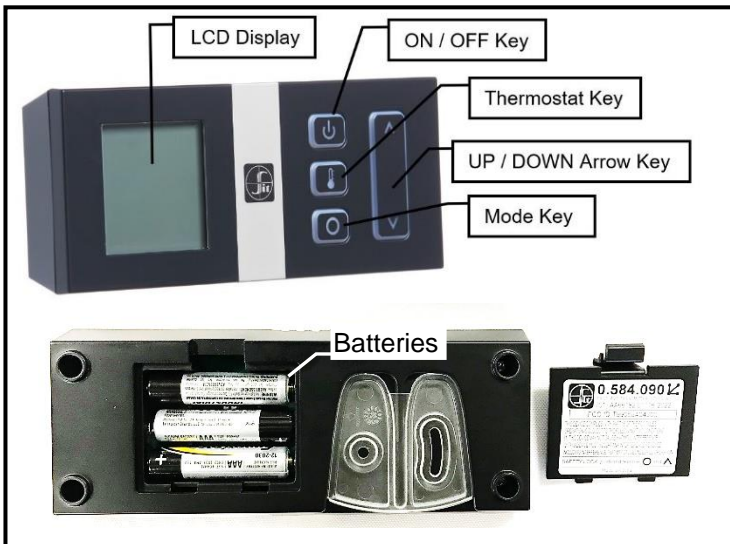

IFC Module

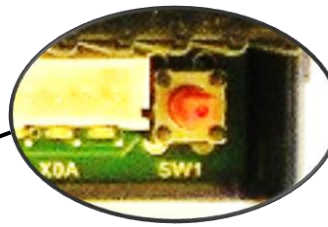

SW1 Button

Pairing Remote Control:

- Install the 3 AAA type batteries in the battery bay, located on the base of the Remote Control. Note polarity of the batteries and insert them as indicated.
- Connect the AC power supply to the IFC Module.
- Press the SW1 button on the IFC Module so the IFC will “beep” and a red LED is illuminated to indicate that the IFC Module is ready to synchronize with a Remote Control within 10 seconds. With the batteries already installed in the Remote Control, push the ON button. The receiver will “beep” four times to indicate the Remote Control’s command is accepted.

The system is now initialized.

Resetting Proflame 2 IFC Module for Manual Use

If the transmitter gets misplaced, is broken, or is no longer wanted the PF2 Module can be reset to a manual system. A manual on/off switch or thermostat may be installed at the X4 connector (this connection is Jumped at the factory) no power is required.

Note: the fireplace accessories (fan, lights) will retain the last settings they had before being reset to manual mode.

The following sequence must be followed to reset the PF2 Module:

- Press the Red **SW1** button until you hear three beeps.

- Within 10 seconds press the **SW1** button again until you hear it beep.
- The PF2 Module may now be turned on/off manually (x4 connector) by a switch (not supplied), the pilot will remain on CPI (continuous pilot ignition) mode, all other functions of main burner, fan and lights will be on the high setting.

Fan Startup and Shutdown Timings:

Fan setting is started with a delay of 5 minutes from the fireplace ignition and stopped with a delay of 12 minutes from the fireplace switching off.

Low Battery Power Detection

When the Remote Control’s batteries are low, a Battery Icon will appear on the LCD display before all power is lost. When the batteries are replaced this icon will disappear.

Battery Backup

The PF2 module is powered by line voltage (AC) with provision of battery backup in case of main power loss. Fans and lighting features will not function with the PF2 Module is powered by battery backup. It is recommended that the 4 x AA batteries are changed before each heating season.

Proflame 2 IPI - Cold Climates – CPI Setting - Proflame 2 Remote Control

Use the CPI setting during cold weather, otherwise the fireplace may have a hard time starting up and establishing a flame. The **CPI** (Continuous Pilot Ignition) setting will keep the firebox and fireplace exhaust vent warm during cold weather. When the firebox and exhaust vent are warm, exhaust gasses will readily flow out of the firebox.

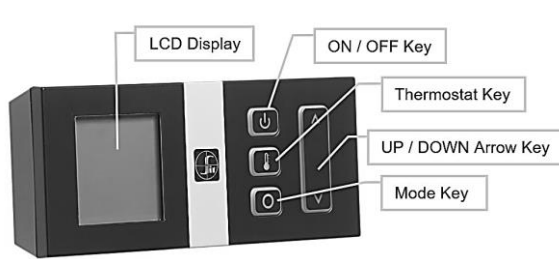

If the firebox and venting are too cold, there is resistance due to the heavy cushion of cold air, and combustion gasses may not rise into the exhaust vent, thus causing the fireplace to cycle or **Lockout** (if this happens see **Lockout Reset Procedures** below).

NOTE: The pilot system for this appliance may be equipped with a **Seven Day Timer**, in which case the pilot flame will be extinguished if the main burner has not been turned ON for seven days. This Seven Day Cycle is reset every time the main burner is cycled ON / OFF and the pilot remains lit. If more than seven days has passed since the main burner has been cycled ON / OFF and the pilot is also out, follow the procedures described in this manual to light the pilot.

To switch from IPI to CPI Mode:

1. Turn the fireplace OFF using the **ON / OFF Key**.

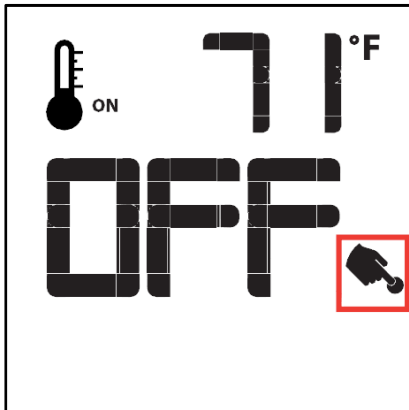

2. Press the **Mode Key**. Display will appear as below.

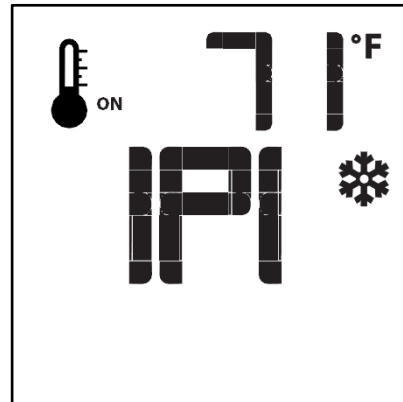

3. Press UP on the **UP / DOWN Arrow Key**. Display will show **CPI**.

The module in the fireplace will beep once to confirm command.

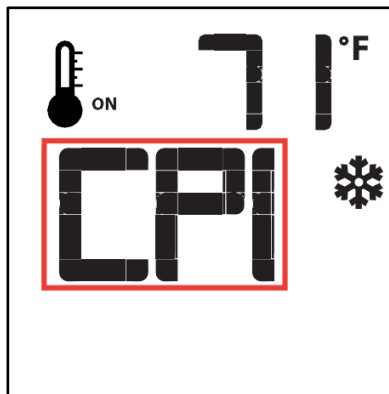

TO RETURN TO IPI (INTERMITTENT PILOT) MODE:

Repeat steps one and two, and then press DOWN on the **UP / DOWN Arrow Key**.

The module in the fireplace will beep once to confirm command.

Lockout Reset Procedures – Proflame 2

If the fireplace has cycled too many times in a short period of time, it will shut down and become unresponsive to any new command.

The LED light on the Proflame 2 module in the fireplace will be flashing red.

This condition is a **Lockout** state.

Lockout Reset Procedure:

1. Disconnect power from the Proflame 2 module in the fireplace for 10 seconds. This includes removing the backup batteries.
2. Once the 10 second interval has passed, reconnect power and reinstall backup batteries. The pilot should now try to light.
3. If the fireplace does not come on, call your fireplace technician.

Proflame 2 Remote Control

Remote-Flame Control

The proflame has six (6) flame levels. With the system on, and the flame level at the maximum in the appliance, pressing the Down Arrow Key once will reduce the flame height by one step until the flame is turned off.

The Up Arrow Key will increase the flame height each time it is pressed. If the Up Arrow Key is pressed while the system is on but the flame is off, the flame will come on in the high position. (Fig. 7 & 8) A single "beep" will confirm reception of the command.



Fig. 7: Flame Off

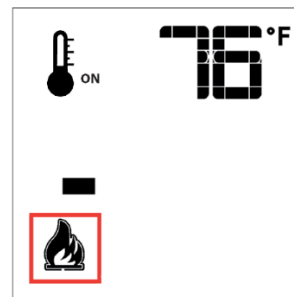

Flame Level 1

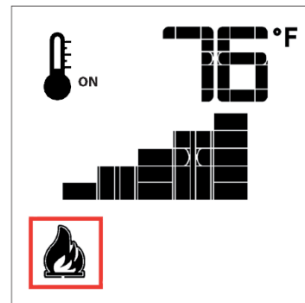
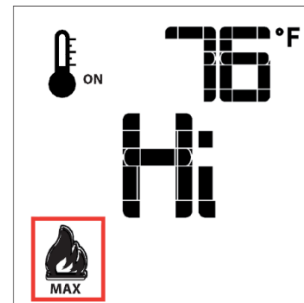

Fig. 8: Flame level 5



Flame Level Maximum

Room Thermostat (Transmitter Operation)

The Remote Control can operate as a room thermostat. The thermostat can be set to a desired temperature to control the comfort level in a room.

To activate this function, press the Thermostat Key (Fig. 1). The LCD display on the Transmitter will change to show that the room thermostat is "ON" and the set temperature is now displayed (Fig. 9). To adjust the set temperature, press the Up or Down Arrow Keys until the desired set temperature is displayed on the LCD screen of the Transmitter.

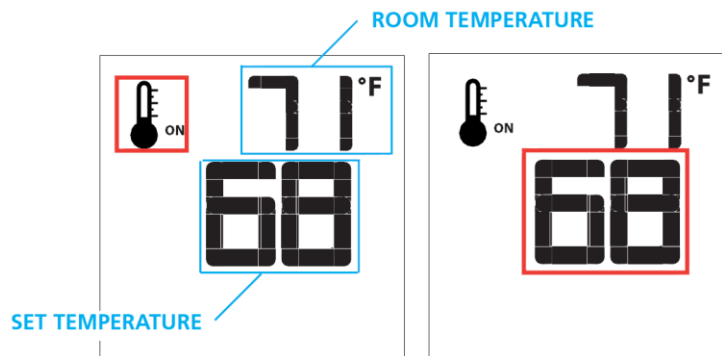

Fig. 9

Fig. 10

Smart Thermostat (Transmitter Operation)

The Smart Thermostat function adjusts the flame height in accordance to the difference between the set point temperature and the actual room temperatures. As the room temperature gets closer to the set point the Smart Function will modulate the flame down.

To activate this function, press the Thermostat Key (Fig. 1) until the word "SMART" appears to the right of the temperature bulb graphic (Fig. 11).

To adjust the set temperature, press the Up or Down Arrow Keys until the desired set temperature is displayed on the LCD screen of the Transmitter (Fig. 12).

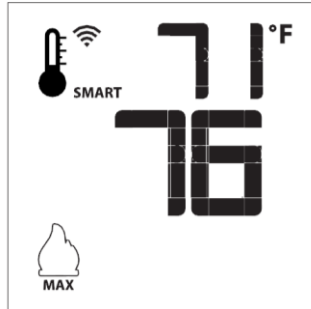

Fig. 11: Smart flame function



Fig. 12

Note:
When Smart Thermostat is activated, manual flame height adjustment is disabled.

FAN OPTION NOT AVAILABLE

Remote dimmer control (Halogen lights only)

The auxiliary function controls the AUX power outlet by the dimmable light control. To activate this function use the Mode Key (fig. 1) to index to the AUX icon (fig. 15 & 16).

The intensity of the output can be adjusted through six (6) levels. Use the Up/Down Arrow Keys (Fig.1) adjust the output level (fig. 16). A single "beep" will confirm reception of the command.

Note:
This function is only available in Room Thermostat or Smart Thermostat Control Mode.



Fig. 15

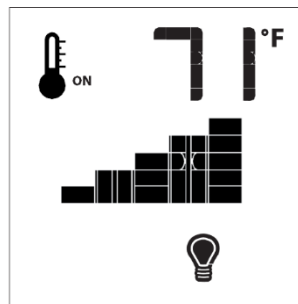
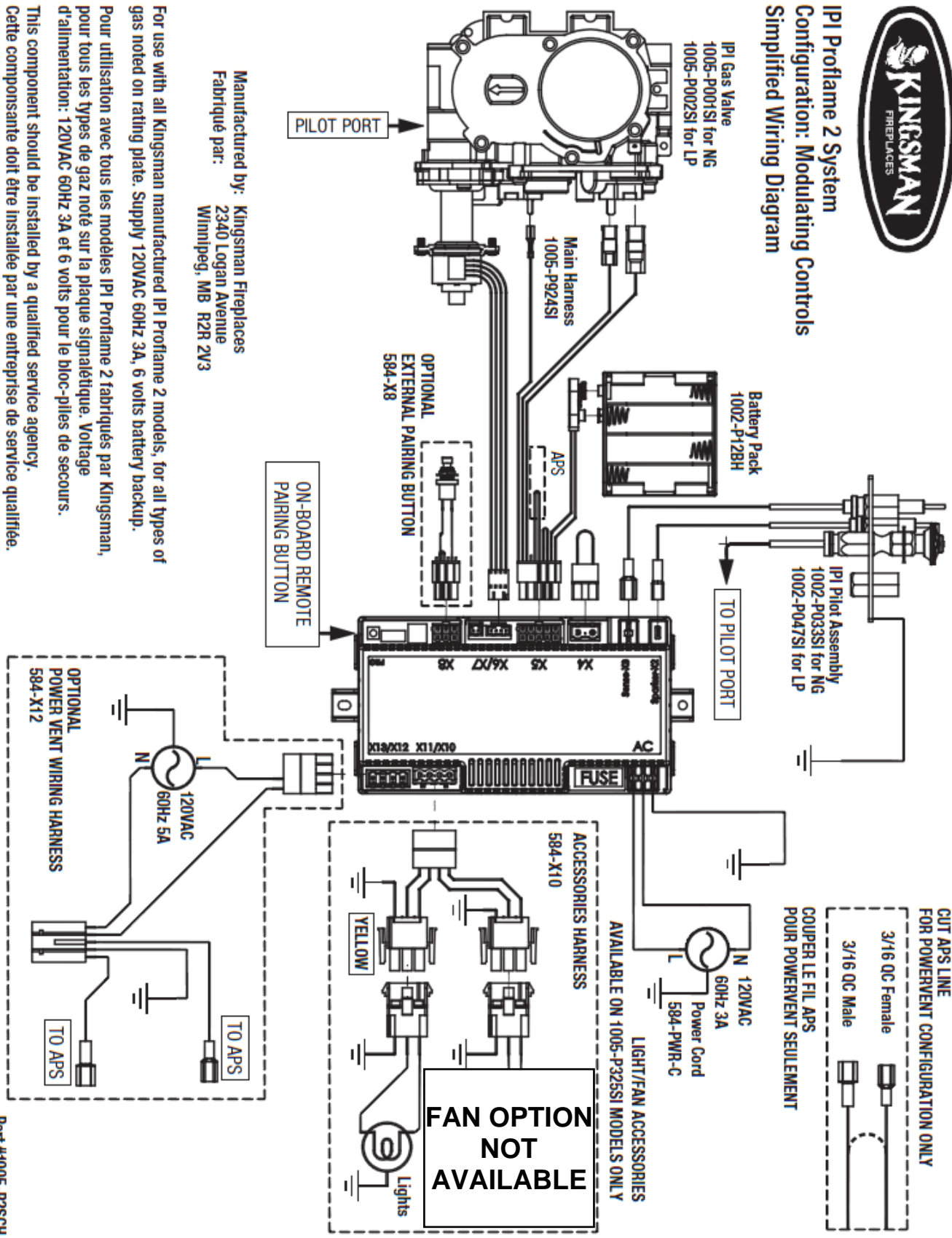

Fig. 16



IPI Profiame 2 System Configuration: Modulating Controls Simplified Wiring Diagram



Manufactured by: Kingsman Fireplaces
 2340 Logan Avenue
 Winnipeg, MB R2R 2V3

For use with all Kingsman manufactured IPI Profiame 2 models, for all types of gas noted on rating plate. Supply 120VAC 60Hz 3A, 6 volts battery backup.

Pour utilisation avec tous les modèles IPI Profiame 2 fabriqués par Kingsman, pour tous les types de gaz noté sur la plaque signalétique. Voltage d'alimentation: 120VAC 60Hz 3A et 6 volts pour le bloc-piles de secours.

This component should be installed by a qualified service agency. Cette composante doit être installée par une entreprise de service qualifiée.

Part #1005-P2SCH

WMBH – Wall Mount Battery Holder – Proflame 1 and 2 IPI Models - Option

The WMBH provides the option for a more convenient and accessible location for the backup batteries.

NOTE: The WMBH is **NOT** a remote control receiver. It functions as a Battery Holder and mode selector switch **ONLY**.

⚠ CAUTION- DO NOT PLUG THE ORIGINAL BATTERY HOLDER SUPPLIED WITH THE APPLIANCE INTO THE WMBH WIRING HARNESS. - NOT FOR USE WITH POWER VENTS -

Parts List:

- [1] Battery Holder
- [1] DCHS Mount Bracket
- [1] Wall Mount Cover Plate
- [1] 16 ft. Wiring Harness

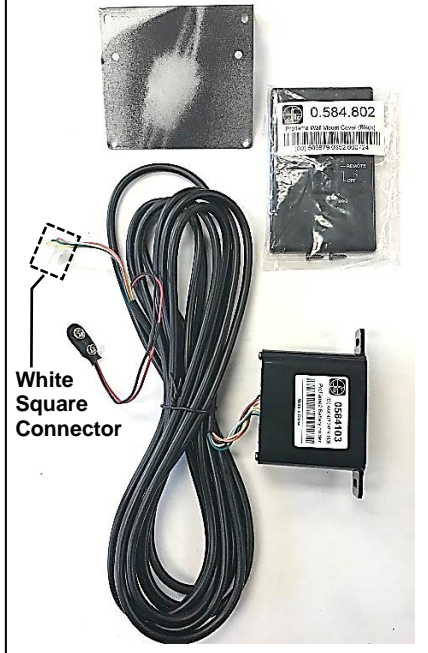

Installation:

- The Battery Holder can be mounted on a vertical wall stud using the DCHS as a mounting bracket.
- Ensure that the face is protruding 1/2" so that the face plate will be flush on the face of the wall.
- Drywall cutout size is 2" wide by 4-1/8" tall.
- Must be installed within 16ft of valve assembly (12ft recommended).

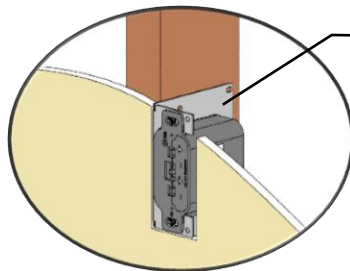

Operating Instructions:

- **Proflame 1:** Set the switch on the Battery Holder to either the **ON** or **REMOTE** position. The WMBH functions as a battery backup should a power outage occur.
- **Proflame 2:** Set the switch on the Battery Holder to the **REMOTE** position. **NOTE:** If the switch on the Battery Holder is set to **ON**, the remote control will be disabled. The WMBH functions as a battery backup should a power outage occur. Refer to the manual that accompanies the Battery Holder for further instructions.

Proflame 1:
-Plug **Battery Connector** into **Battery Holder** connection on wiring harness.

-The **Square Plug Connector** on the 16ft wiring harness is not used.

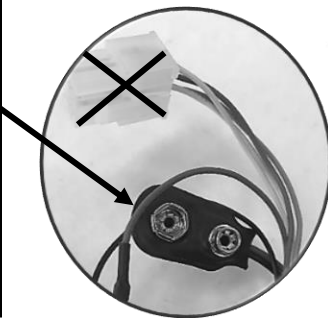

Proflame 2:
-Plug the **Square Plug Connector** into the **User Interface Socket** in the P2 Module.

-Plug the **Battery Connector** into **Battery Holder** connection on the Proflame 2 wiring harness.

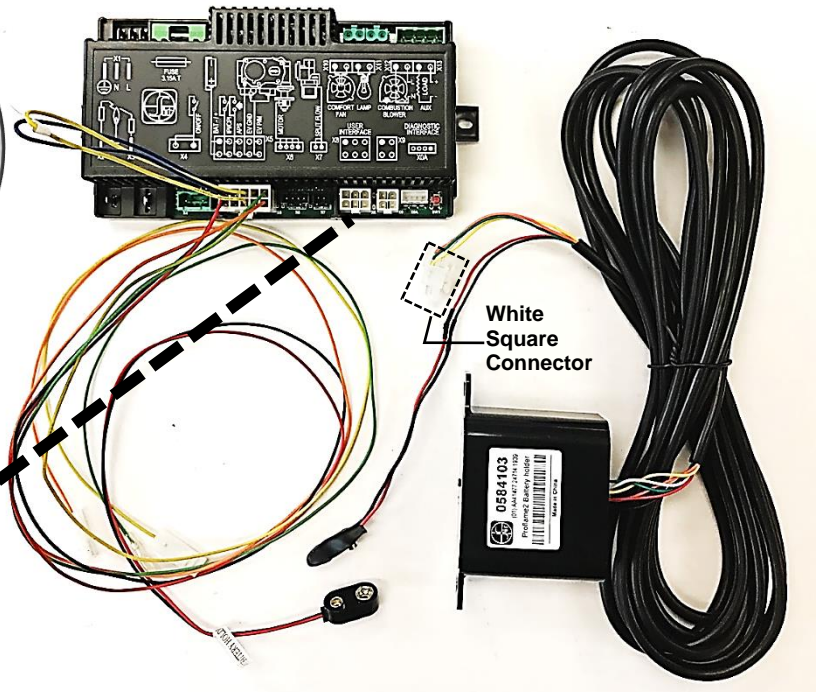
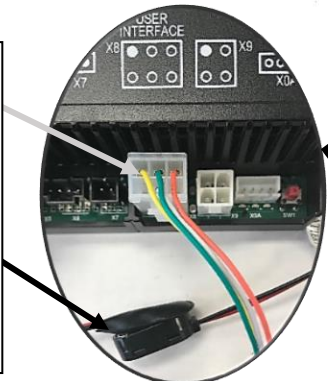

MQZCVBG34

Vent Terminal Clearances

NOTE: A HORIZONTAL VENT CERTIFIED GUARD (SAFETY CAGE) IS AVAILABLE WHEN REQUIRED BY LOCAL CODES.

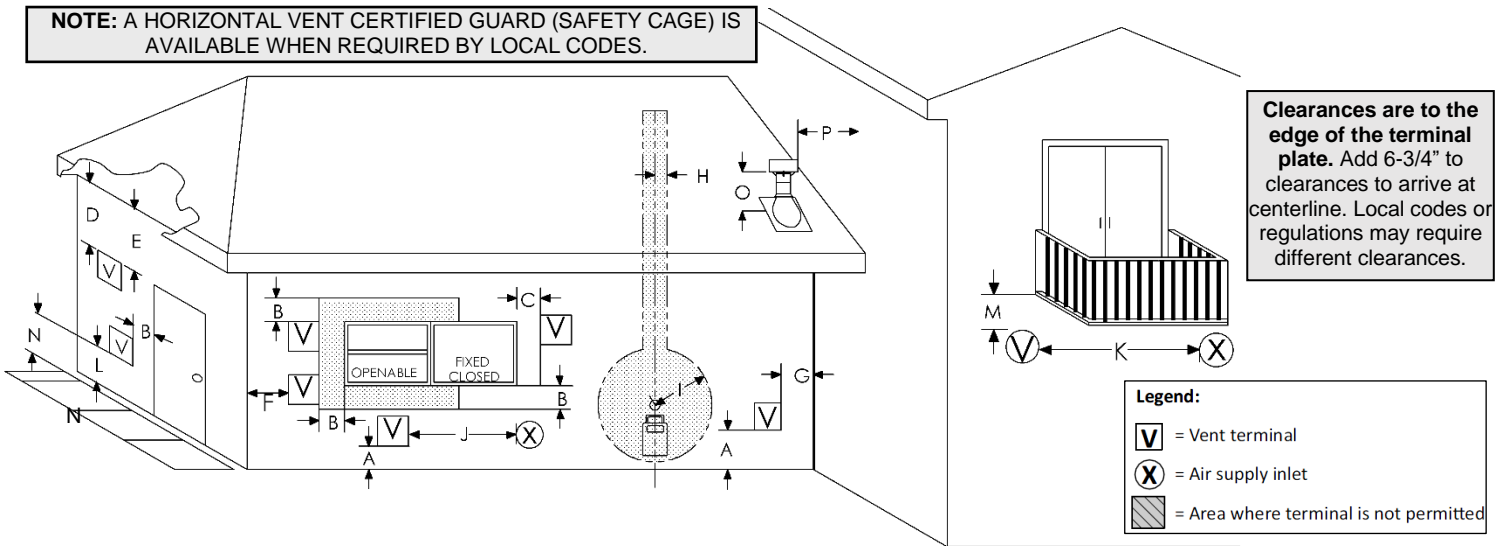

| | | Canadian installations ¹ | US installations ² |
|---|--|---|--|
| A | Clearance above grade, veranda, porch, deck, or balcony | 12 in (30 cm) | 12 in (30 cm) |
| B | Clearance to window or door that may be opened | 6 in (15 cm) for appliances ≤ 10,000 Btu/h (3 kW), 12 in (30 cm) for appliances > 10,000 Btu/h (3 kW) and ≤ 100,000 Btu/h (30 kW), 36 in (91 cm) for appliances > 100,000 Btu/h (30 kW) | 6 in (15 cm) for appliances ≤ 10,000 Btu/h (3 kW), 9 in (23 cm) for appliances > 10,000 Btu/h (3 kW) and ≤ 50,000 Btu/h (15 kW), 12 in (30 cm) for appliances > 50,000 Btu/h (15 kW) |
| C | Clearance to permanently closed window | 12 inches (30cm) recommended to prevent condensation on window | 12 inches (30cm). 9 inches (23cm) for appliances 50,000 Btu's and lower |
| D | Vertical clearance to ventilated soffit located above the terminal within a horizontal distance of 2 feet (61 cm) from the center line of the terminal | 18 inches (46cm) | 18 inches (46cm) |
| E | Clearance to unventilated soffit | 12"(30cm) non-combustible, 17"(43cm) combustible | 12" non-combustible*, 17"combustible* |
| F | Clearance to outside corner | 3" (8cm) * | 3" * |
| G | Clearance to inside corner | 3" (8cm) non-combustible*, 7" (18cm) combustible* | 3" non-combustible*, 7" combustible* |
| H | Clearance to each side of center line extended above meter/regulator assembly | 3 ft (91 cm) within a height 15 ft (4.5 m) above the meter/regulator assembly | 3 ft (91 cm) within a height 15 ft (4.5 m) above the meter/regulator assembly |
| I | Clearance to service regulator vent outlet | 3 ft (91 cm) | 3 ft (91 cm)* |
| J | Clearance to non-mechanical air supply inlet to building or the combustion air inlet to any other appliance | 6 in (15 cm) for appliances ≤ 10,000 Btu/h (3 kW), 12 in (30 cm) for appliances > 10,000 Btu/h (3 kW) and ≤ 100,000 Btu/h (30 kW), 36 in (91 cm) for appliances > 100,000 Btu/h (30 kW) | 6 in (15 cm) for appliances ≤ 10,000 Btu/h (3 kW), 9 in (23 cm) for appliances > 10,000 Btu/h (3 kW) and ≤ 50,000 Btu/h (15 kW), 12 in (30 cm) for appliances > 50,000 Btu/h (15 kW) |
| K | Clearance to a mechanical air supply inlet | 6 ft (1.83 m) | 3 ft (91 cm) above if within 10 ft (3 m) horizontally |
| L | Clearance above paved sidewalk or paved driveway located on public property | 7 ft (2.13 m) | *(Notes: 2) |
| M | Clearance under veranda, porch, deck, or balcony | 12" (30 cm) non-combustible, 17" (43cm) combustible ‡ | 12 in (30 cm) * |
| N | Where a vent termination may cause hazardous frost or ice accumulations on adjacent property surfaces | ** (Notes: 1) | *(Notes: 2) |
| O | Clearance above highest point of exit on roof | 18 in (45cm) | 18 in (45cm) |
| P | Clearance to perpendicular or adjacent wall | 24 in (60cm) | 24 in (60cm) |

Notes:

1) In accordance with the current CSA B149.1, Natural Gas and Propane Installation Code.

2) In accordance with the current ANSI Z223.1/NFPA 54, National Fuel Gas Code.

* Clearance in accordance with local installation codes and the requirements of the gas supplier.

** A vent shall not terminate directly above a paved sidewalk or paved driveway that is located between two single family dwellings and serves both dwellings. Note: This does not apply to non-condensing appliances (Province of Ontario ONLY).

‡ Permitted only if veranda, porch, deck, or balcony is fully open on a minimum of two sides beneath the floor.

It is imperative that the vent termination be located observing the minimum clearances as shown. There must not be any obstruction such as bushes, garden sheds, fences, decks or utility buildings within 24" from the front of the termination plate.

Do not locate termination where excessive snow or ice build-up may occur. Be sure to check vent termination area after snow falls and clear to prevent accidental blockage of venting system. When using snow blowers, make sure snow is not directed towards vent termination area. Venting terminal shall not be recessed into a wall or siding. If finishing the outside wall with vinyl or wood siding it is **required** that a Siding Shield be installed, Part Number ZDVSSLR.

General Vent Installation Information

⚠ WARNING: DO NOT mix parts from different systems unless stated in the manual.

This gas appliance is approved to be vented either through the side wall or vertically through the roof. Only Kingsman Flex (Z-Flex) Venting Kits and components specifically approved and LABELED for this appliance may be used. This appliance is also approved for use with 5 x 8 MG-Duravent Direct Vent system (DirectVent Pro and DirectVent Pro Concentric Flex), BDM Pro Form Direct Vent, Ameri-Vent Direct Vent Pipe System, ICC Excel Direct, Metal Fab Sure-Seal DV and Selkirk Direct Temp.

Rigid or Hard Pipe

When using 5 x 8 MG-Duravent, Ameri-Vent pipe, BDM Pro Form Direct Vent, ICC Excel Direct, Metal Fab Sure-Seal DV and or Selkirk Direct Temp, 5 x 8 MG Duravent hard pipe, Adapter # Z58DFA must be used on units with a sloped flue. Follow installation instructions provided by MG-Duravent/Ameri-Vent/Selkirk Direct Temp, ICC Excel Direct, and Metal Fab Sure-Seal DV for installation of pipe and adhere to the clearance to combustibles provided in this manual. A starter piece of MG Duravent 5/8" will be required when using ICC Pipe on Enclave or Serene models.

Apply a bead of Mill Pac high temp sealant at the flue of the appliance when using a Duravent adapter.

NOTE: It is critical to the proper and safe operation of this fireplace that on all connections the inner liner and the outer casing are both caulked with liberal amounts of sealant. Do not use any kind of tape or silicone other than that recommended in this manual. Use Mill Pac Sealant.

NOTE: These actions are essential for proper resealing or reinstallation of the vent-air intake system.

REMEMBER THAT A 1/4" VERTICAL RISE IS REQUIRED FOR EVERY 12" OF HORIZONTAL RUN.

Flex Pipe Venting

Kingsman Flex pipe is shipped in unexpanded length. When installing pipe expand the lengths. Pipe can be expanded to twice their lengths e.g., 4ft to 8ft. Fully expand pipe and cut off excess.

Do not use more than 2 couplers (**Order ZDV5FC & ZDV8FC – DO NOT fabricate couplers**) to extend short pipes. Single sections are preferred in an installation attaching at the fireplace and termination.

Place the spring spaces provided approximately every two feet to stabilize 5" flex in the center of 8" flex. When forming bends place spring in bend or before and after. (See Fig. 1). Horizontal runs require support metal straps every 2 feet. In offset installation support straps should be used to stabilize pipe.

Expand 5" and 8" flex pipe to the point that the 8" protrudes approximately 2 to 3 inches past outer wall and the 5" flex protrudes approximately 2 to 3 inches past the 8" flex. (See Fig. 1). Attach the 5" pipe to the termination first and secure with sealant and screws then attach the 8" flex to the termination with caulking and screws. Termination may then be moved back to the outer wall and attached to home screwing into the framing. Silicone around termination to waterproof. If siding shield is going to be used attach this using same attaching hole as the top of termination after termination has been caulked for water proofing.

Use Hi Temp Sealant

Apply a bead of Mill Pac high temp sealant to all joints and use four screws to secure each pipe at fireplace, termination and any joint if joining any sections of pipe.

Preventing Moisture Problems

Insulate wall thimbles and attic insulation shields for vertical attic terminations with non-combustible mineral wool Insulation (Roxul, Rockwool, Thermafiber UltraBatt, etc.). Attach and seal the outer perimeter of the wall thimble or attic insulation shield to the existing vapor barrier.

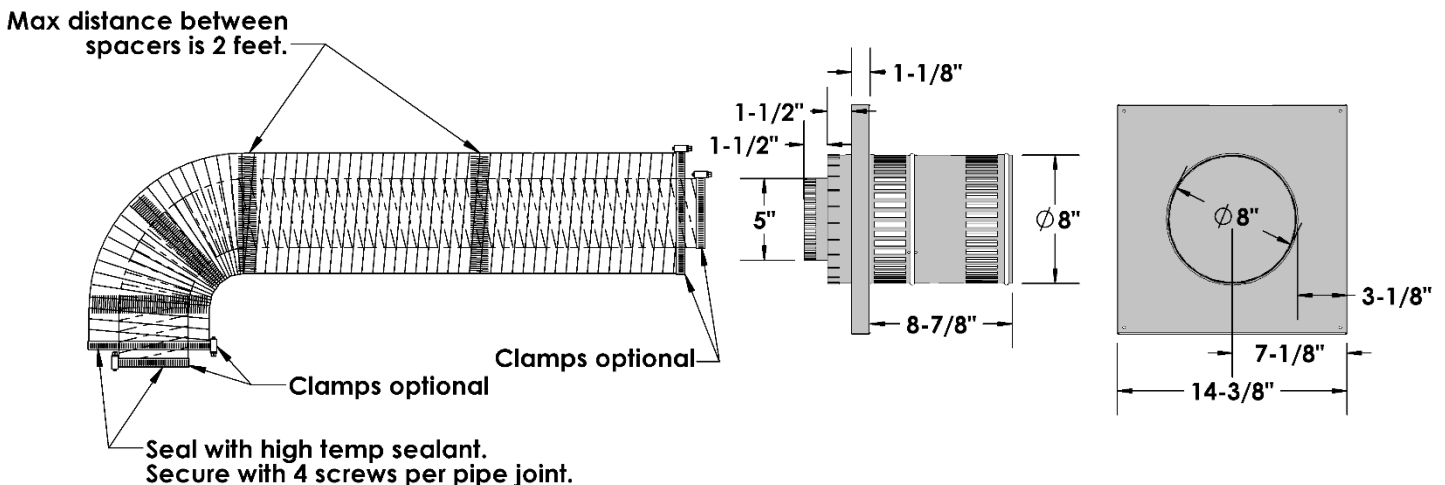

1. To determine the minimum distance from the bottom of fireplace to center of vent see the Framing Your Gas Fireplace section. Cut a hole through the wall allowing for a 12" x 12" (inside diameter) in combustible walls for wall thimble or a 9" diameter hole in a non-combustible wall (See Figure 2).
2. For the clearance to combustibles above a 90-degree bend see Clearance to Combustibles section.
3. Select the approximate vent length, precise measurements are not needed as your flex pipe can be expanded to twice its shipped length for ease of installation.
4. To install wall thimble center over 12" x 12" (inch) framing from both sides of wall and secure. Route flex vent pipe through wall thimble (See Figure 1).
5. Before joining pipes, apply a bead of high temperature sealant (Mill Pac) to end of pipe. First attach the five-inch (5") flue pipe to the vent termination with sealant, and secure with the four screws provided. At this time make sure the spacer springs are attached to the (5") flex pipe as required. Then attach the eight-inch (8") pipe by the same method.
6. Mount vent termination and seal to wall using caulking around the wall thimble to weather proof. After installing the vent termination, double check to make sure the pipe extends properly through wall thimble and into vent termination.
7. Before joining pipes to fireplace flue, apply a bead of high temperature sealant (Mill Pac) to end of pipe. First attach the five-inch (5") flue pipe to fireplace with sealant, and secure with the four screws provided. At this time verify that the spacer springs are attached properly to the (5") flex pipe as required. Then attach the eight-inch (8") pipe by the same method.
8. Support horizontal pipes every two (2) feet (61 cm) with metal strap bands. Re-check fireplace to make sure it is levelled and properly positioned and secured.
9. Support vertical pipes to maintain a minimum of 1" or greater clearance to combustibles with metal strapping bands.
10. If finishing the outside wall with vinyl or wood siding it is **required** that a Siding Shield be installed, Part Number ZDVSSLR.

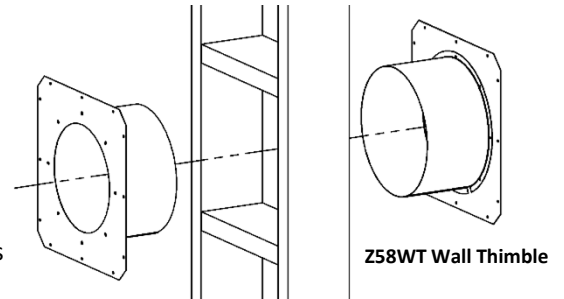

Note: Vent Termination must not be recessed into wall or siding.

WARNING: A HORIZONTAL VENT CERTIFIED GUARD (SAFETY CAGE) IS AVAILABLE WHEN REQUIRED BY LOCAL CODES.

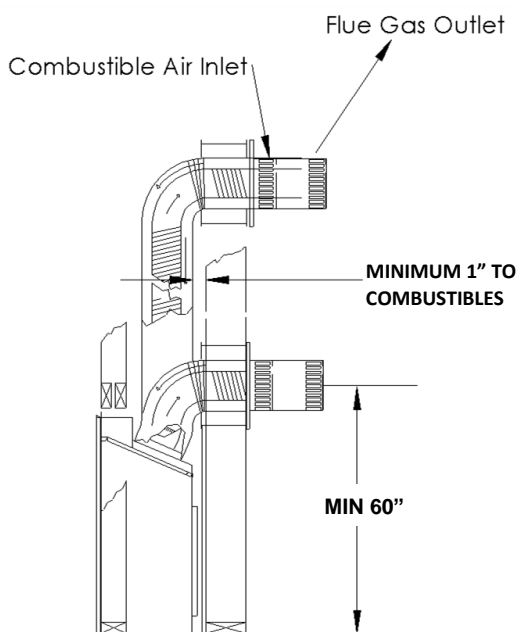

Figure 1

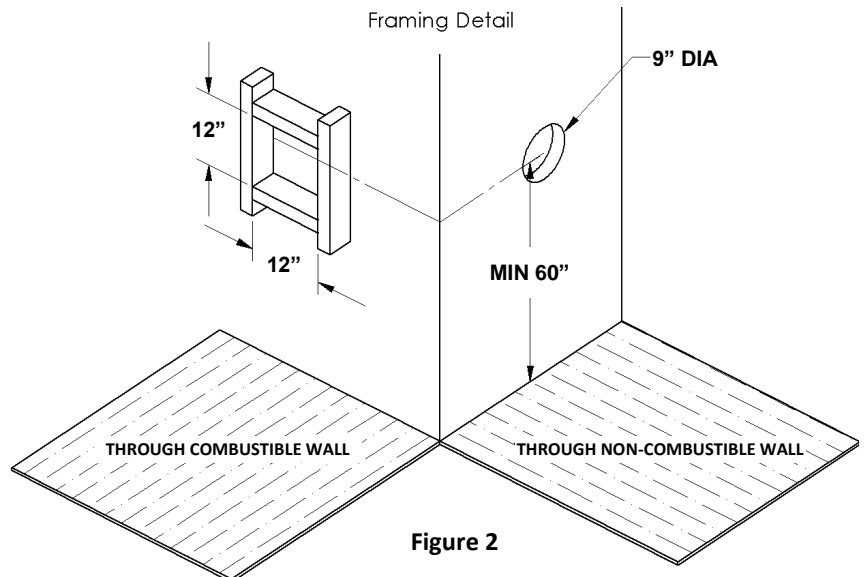

Figure 2

MQZCVBG34 Venting Routes and Components

Venting Routes and Components

Since it is very important that the vent system maintain its balance between the combustion air intake and the flue gas exhaust, certain limitations as to vent configurations apply and must be strictly adhered to.

The table showing the relationship between vertical and horizontal side wall venting will help to determine the various vent lengths.

The maximum horizontal run is 20ft (6.1m) when the vertical rise is 8 ft (2.4m). See **Example A** below.

Note: 1/4" vertical rise is required for every 12" of horizontal run.

The maximum number of 45° bends per side wall installation is four (4) in the horizontal run. You must reduce the length of the horizontal by 18" (45cm) for each 45° bend.

The maximum vertical run is 43ft (13.1m).

Special Note: For each 45° bend installed in the horizontal run, the length of the horizontal run must be reduced by 18" (45cm). This does not apply if the 45° bends are installed on the vertical part of the vent system. **Example:** If according to the table, the length of the horizontal run is 10ft (3m), and two 45° bends are required, the horizontal run length must be reduced to 7ft (2.1m).

Two (2) additional 90° bends (or the equivalent) are allowed. The horizontal run must be reduced by 36" (90cm) for each 90° bend, or 18" (45cm) per each 45° bend.

IMPORTANT:

Always locate the fireplace in such a way that a minimum of offsets and/or horizontal runs are required. For every 12" (30cm) horizontal run, 1/4" (6mm) vertical rise is required.

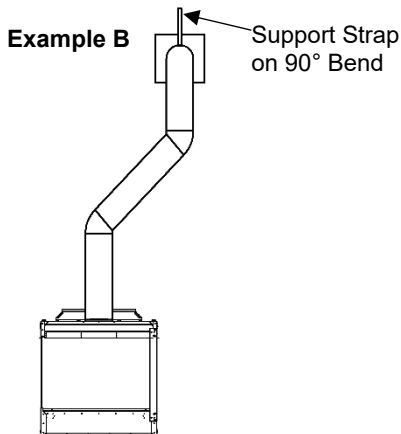
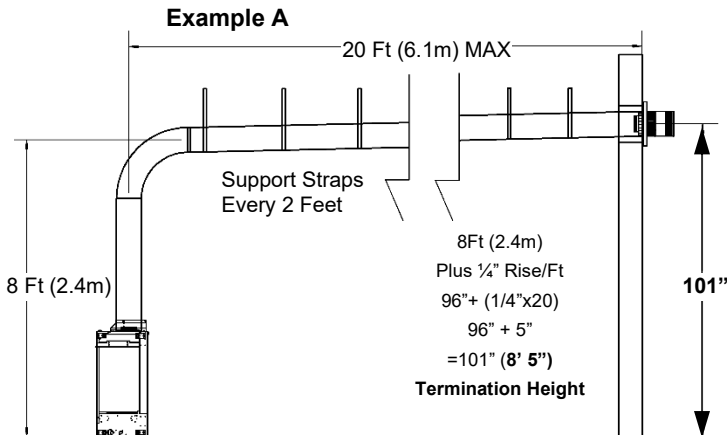

How to Use the Horizontal Vent Table

1. Determine the height of the system and the number of bends required.
2. Having determined the vertical distance, determine the maximum horizontal section allowed.
3. Vent table has been established for 90° horizontal/vertical runs. Flex pipe runs not having 90° bends will not fall into vent table standards.

Horizontal Venting Table from Bottom of Fireplace

For venting to a maximum of 43ft (13.1 meters)

| Total Vertical | | Max Total Horizontal | |
|----------------|--------|----------------------|--------|
| Feet | Meters | Feet | Meters |
| (60" Min) | 1.52 | 4 | 1.2 |
| 6.5 | 2 | 15 | 4.6 |
| 7 | 2.1 | 20 | 6.1 |
| 8 | 2.4 | 20 | 6.1 |
| 9 | 2.75 | 20 | 6.1 |
| 10 | 3.0 | 20 | 6.1 |
| 11 | 3.4 | 20 | 6.1 |
| 12 | 3.7 | 20 | 6.1 |
| 13 | 4.0 | 20 | 6.1 |
| 14 | 4.3 | 20 | 6.1 |
| 15 | 4.6 | 20 | 6.1 |
| 20 | 6.1 | 20 | 6.1 |
| 25 | 7.6 | 15 | 4.6 |
| 30 | 9.1 | 10 | 3.0 |
| 43 (Max) | 13.1 | 0 | 0 |

NOTE: A length of horizontal vent run **less** than the maximum is acceptable (such as up and out) provided that clearances to combustibles are maintained and proper procedures are followed.

NOTE: The final location of the fireplace must be such that the horizontal vent dimensions fall within those stated in the Horizontal Venting Table. The Maximum Vertical vent run is 43ft (13.1m).

IMPORTANT:

Minimum clearance between vertical vent pipes and combustible materials is 1" (25mm).

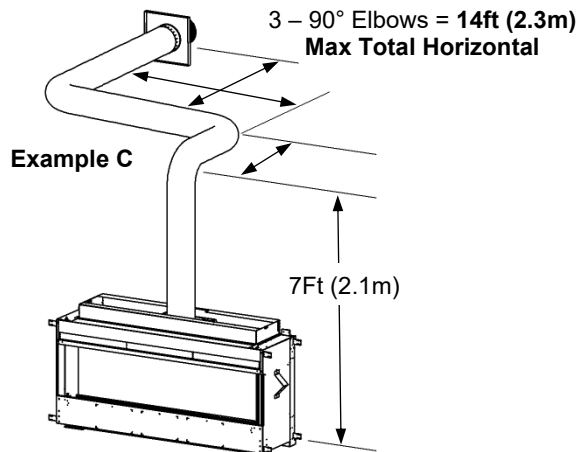

The Flue Restrictor is located in the top of the Firebox in front of the Flue Opening.

For power vent and longer vertically vented installations it is necessary to use the Flue Restrictor. The Flue Restrictor is set fully open from the factory for short horizontal and vertical runs.

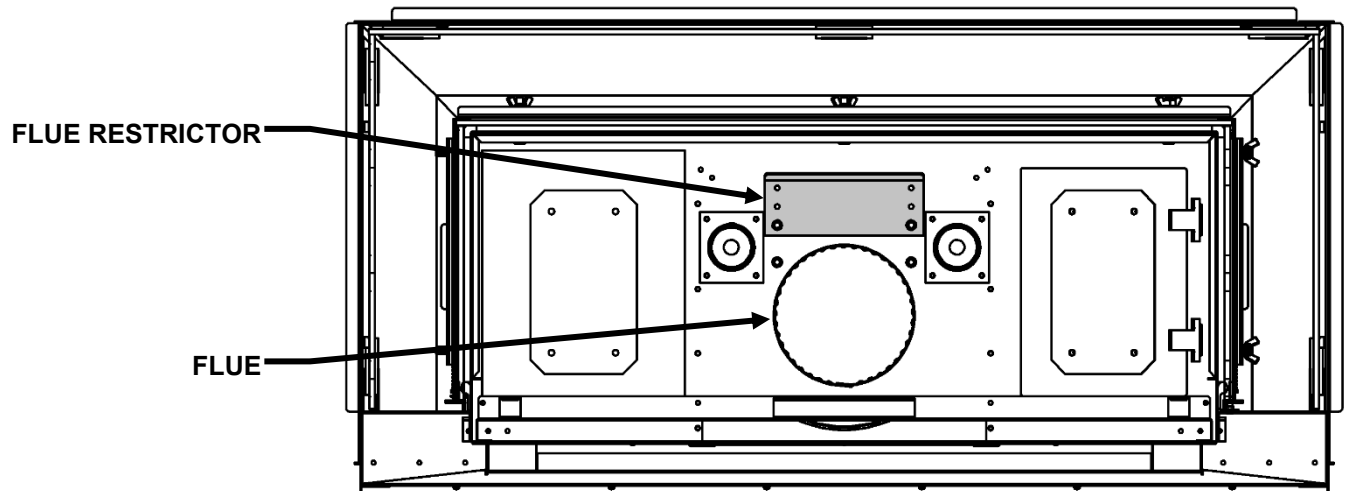
INSIDE TOP OF FIREBOX

To adjust the Flue Restrictor, remove DT Screws from the firebox top and install the Flue Restrictor over the flue, partially blocking it. **Replace ALL DT Screws.**

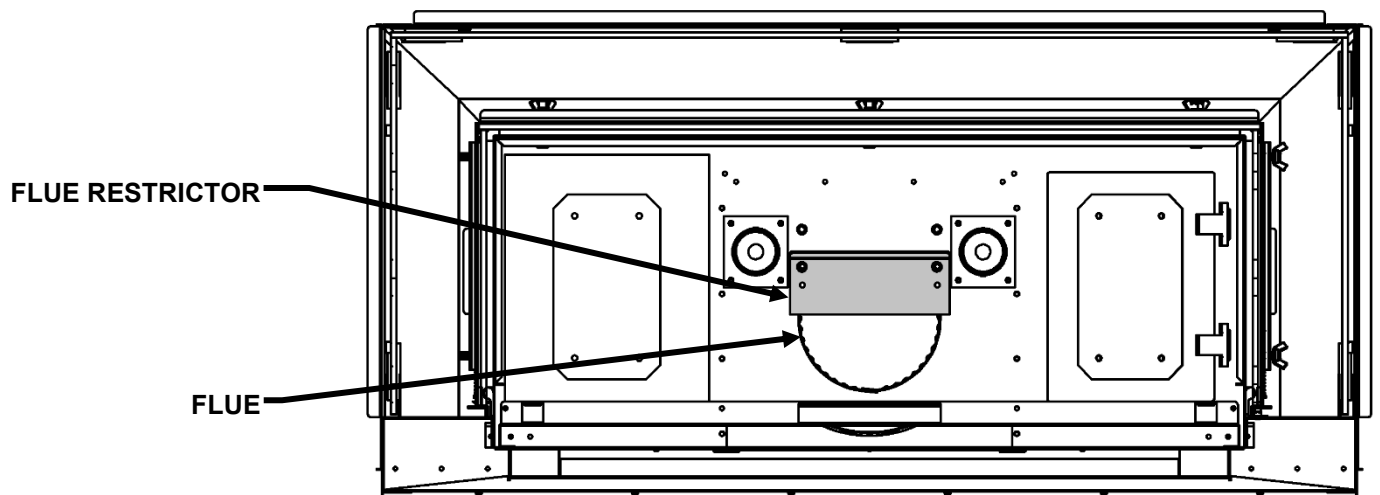
INSIDE TOP OF FIREBOX

Venting Straight Up Through Roof

An Attic Insulation Shield must be installed where the vent passes from a lower living space into an attic space where the chimney is not enclosed. It is designed to keep insulation materials away from the chimney. When installing the Attic Insulation Shield where the chimney passes from a living space to an attic space, install the shield from below and nail in place using 1" spiral nails. A fire stop must be installed on the bottom side of the joists when passing through a ceiling or floor. If an attic insulation shield is to be used, a fire stop is not required.

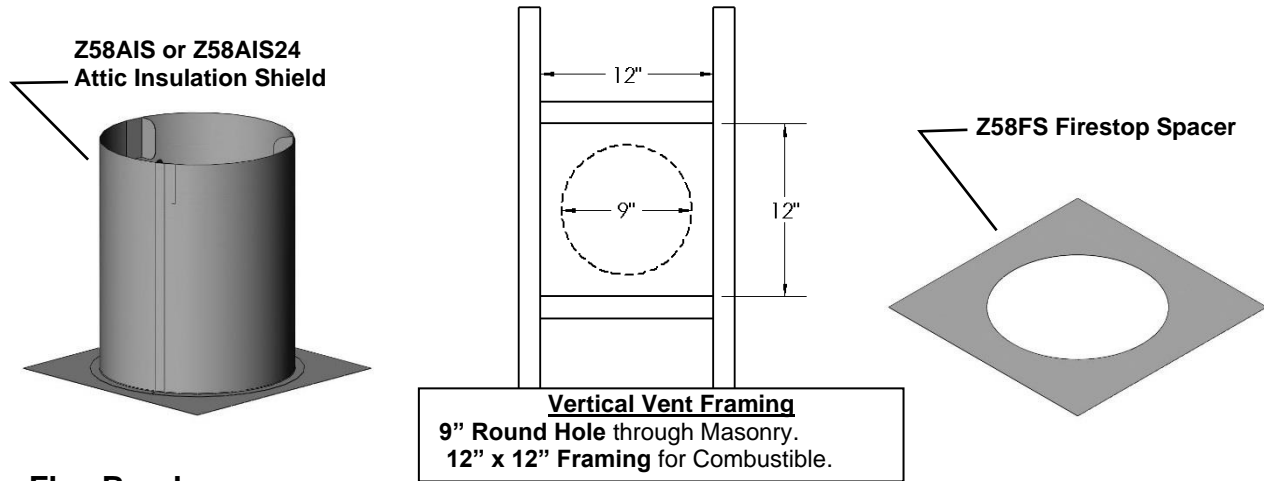

Using Flex Bends

Avoid cutting joists by offsetting the flex pipe.

When using 45° bends a bend support is required directly above the highest bend.

When installing a bend in a joist area a minimum of 4" clearance to combustibles to the top of bend must be maintained, sides and bottom of pipe, a 1" clearance to combustibles must be maintained. If running horizontal through an area a 1-1/2" minimum clearance to the top of the horizontal pipe must be maintained.

Maximum vertical height of system should not exceed 43 feet.

Use roof support and rigid pipe at roof level. Flex pipe is not permitted within roof support.

When penetrating the roof a rigid galvanized pipe must be used. Attach flex pipe to the rigid pipe with high temperature sealant, secure with four screws assuring the flex pipe and rigid pipe are secured. Attach rigid pipe to termination with sealant and screw with 4 sheet metal screws. The inner flex pipe must be secured with 4 screws which must penetrate both the flex pipe and inner section of termination. Attach 8" rigid pipe to 8" termination with sealant and screw with 4 sheet metal screws.

Vertical termination clearance is 18" [45.7cm] above the roof, measured from highest point of exit on the roof line.

Support vertical pipes to maintain minimum of one inch or greater clearances to combustibles.

Roof Flashing

Ensure that you have the proper roof flashing by checking your roof pitch using a level and two rulers, or by using a roof pitch card. Slide a Roof Flashing suitable to your roof slope over the vent. Place the edge of the flashing plate that will be on the higher part of the roof slope under the shingles. Both the sides and the lower edge lay on top of the shingles.

NOTE: At the top edge of the flashing plate, lift the shingles and nail the plate to the roof deck, then cement the shingles to the plate with a suitable waterproof mastic.

Ensure that the chimney is plumb. Square up the flashing plate and nail in place to the roof deck. Use 12 nails with neoprene washers or cover the heads with a suitable waterproof mastic. Wrap the storm collar around the vent above the flashing. Secure the ends together loosely with nut and bolt supplied. Slide the collar down the vent until it comes in contact with the flashing. Tighten the bolt and seal the Storm Collar to the vent with a suitable waterproof non-combustible mastic.

The flashing and storm collar should be painted to match the roof shingles. This will extend its life and improve the appearance. Clean, prime and paint with suitable painting products.

Vertical Venting in Cold Climates

In cold climate conditions where temperatures go below -10 degrees Celsius or 14 degrees Fahrenheit, we recommend that the chase be insulated and where the vent pipe enters into the attic space that the pipe be wrapped with an insulated Mylar sleeve. This will increase the temperature of the vent and help the appliance to vent properly in cold weather conditions.

It is also important in vertical vented direct vent appliances that the appliance be operated daily during the winter months as this will help stop the termination from freezing up.

We recommend using a thermostat set at room temperature to allow the unit to cycle.

For IPI models it may be necessary to set the appliance to Standing Pilot mode to maintain heat in the cavity. The purpose of this procedure is to prevent cold air from penetrating the chimney and then onto the living space. Therefore, when the internal temperature is slightly elevated the fireplace is able to freely exhaust its combustion and hence making it easier to start up.

-ALSO SEE DIAGRAMS ON FOLLOWING PAGES-

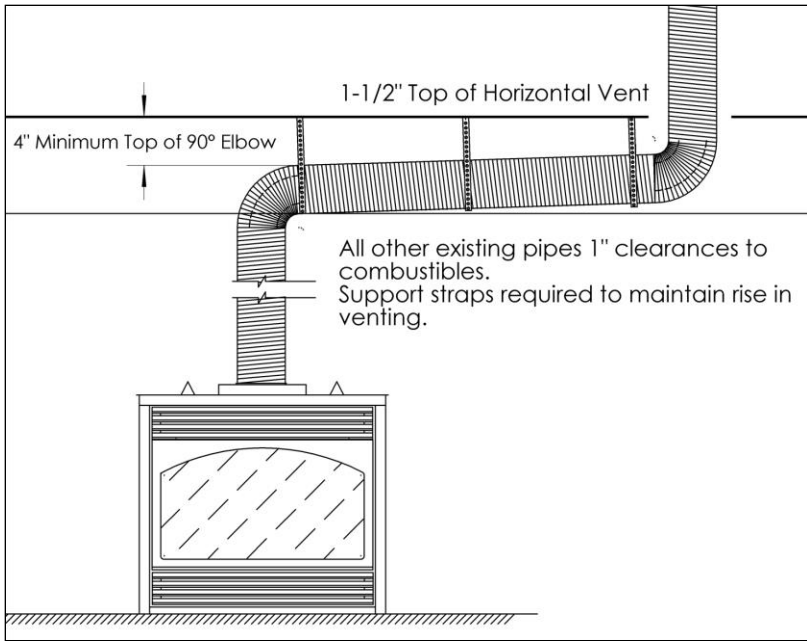

Clearances in horizontal venting.

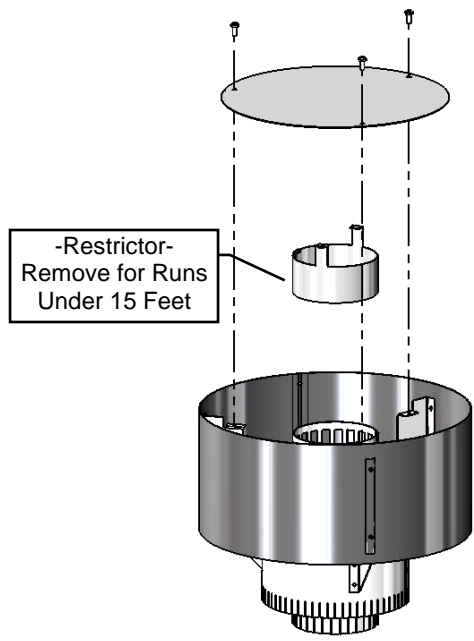

Z58VT

Clearance to adjacent or perpendicular wall is 24 inches (60 cm). (Recommended to prevent re-circulation of exhaust products. For additional requirements check local codes.)

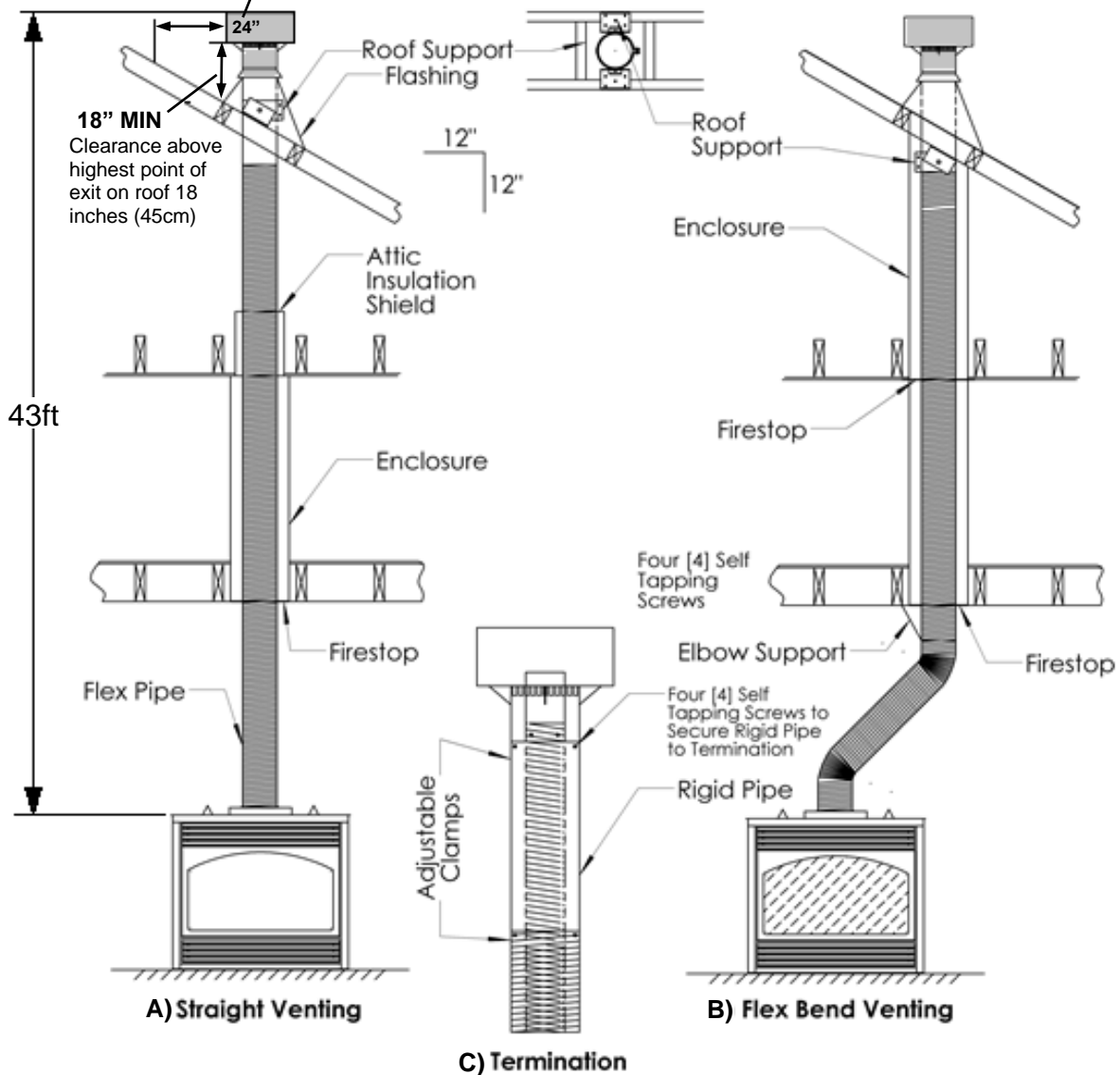

A) Straight-through roof support configuration; B) Flex bend configuration; C) Termination mounting

MQZCVBG34 Venting - Cathedral Ceiling

Just as with a normal ceiling, an **Attic Insulation Shield** must be installed where the fireplace vent passes from a lower living space into an attic space when installing a fireplace into a room with a cathedral ceiling. This will keep insulation and other combustibles away from the vent pipe. A **Support Box** must be built in order to install the Attic Insulation Shield correctly.

A **Fire Stop** must be installed on the bottom side of joists when passing through an uninsulated ceiling or floor.

WARNING: HEAT CANNOT BE DISCHARGED INTO THE WALLS, FLOOR, OR CEILING. Heat must exit through the required 2-1/4" opening at the top of the chase. **Use Hi Temp Sealant.** Insulate Attic Insulation Shield with non-combustible mineral wool insulation, and attach and seal outer perimeter to the existing vapor barrier.

Z58AIS24 or Z58AIS Attic Insulation Shield - Trim to 12" to match chase depth.

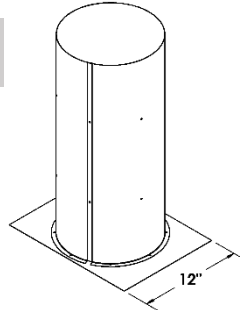
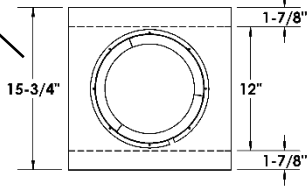

Z58FS Firestop - Hole may need to be elongated to due to ceiling angle. Trim to 12" to match chase depth if necessary.

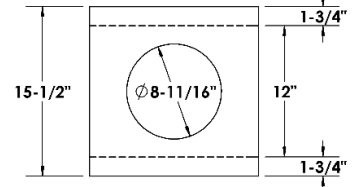
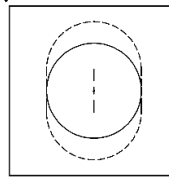

Option 1 - Angled Chase Opening

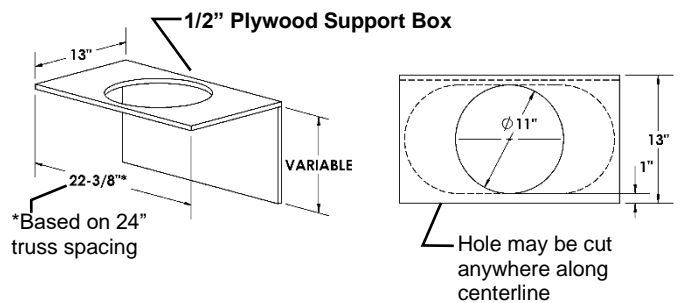

Option 2 - Horizontal Chase Opening

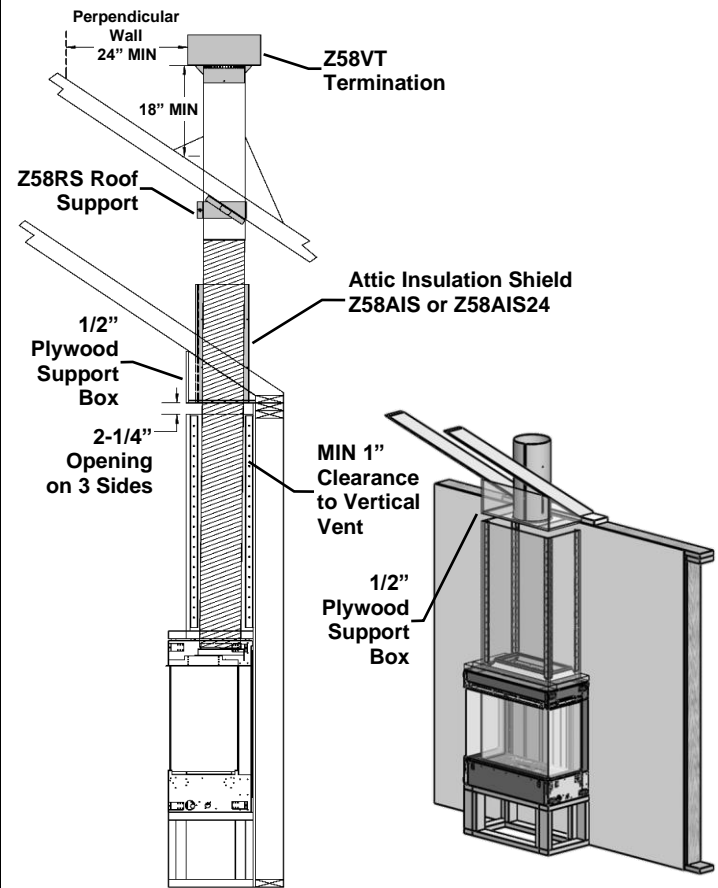
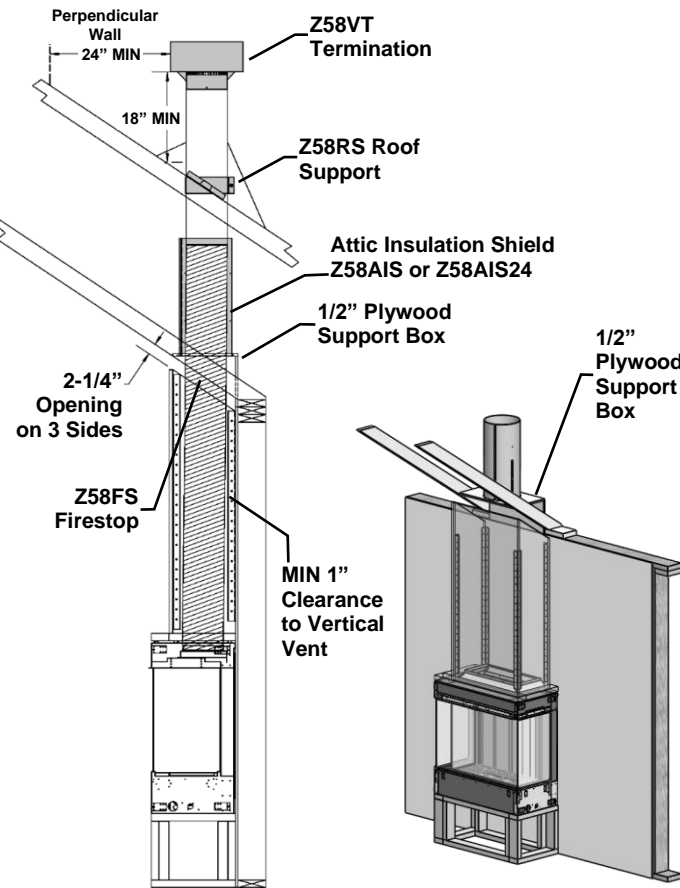
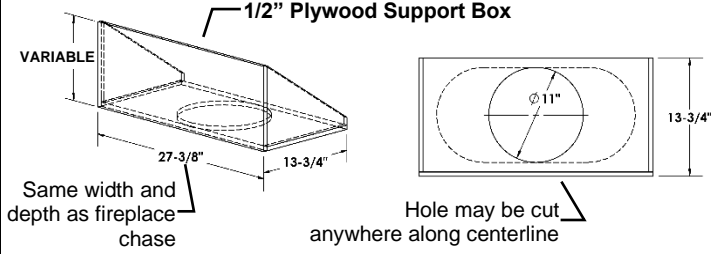

Fireplace Installations Using Co Linear Flex Kits for Units: MQZCVBG34NE2, MQZCVBG34LPE2

⚠ WARNING CO-AXIAL TO CO-LINEAR VENTING CONFIGURATIONS MUST ONLY BE USED IN A NON-COMBUSTIBLE CHIMNEY OR ENCLOSURE. INSTALLATION IN A COMBUSTIBLE ENCLOSURE COULD RESULT IN A FIRE. MINIMUM VENT HEIGHT IS 12 FEET. MAXIMUM VENT HEIGHT IS 43 FEET.

| Hard Pipe Adapter | Co Axial to Co Linear Appliance Connector Options | Size of Flex- 4x3 (Min 12ft / Max 43ft) | Termination Options |
|-------------------|---|--|---|
| 58DVA-X45 | 46DVA-34CLAA 46DVA-GCL34 | I43FK25 (25ft Kit) ZDV3FC (Flex Connectors) ZDV4FC (Flex Connectors) | IDVVT43 (Kingsman)- Requires I43FK25 (25ft Flex Kit) 46DVA-CL33H High-Wind Termination (c/w35ft of Flex) |

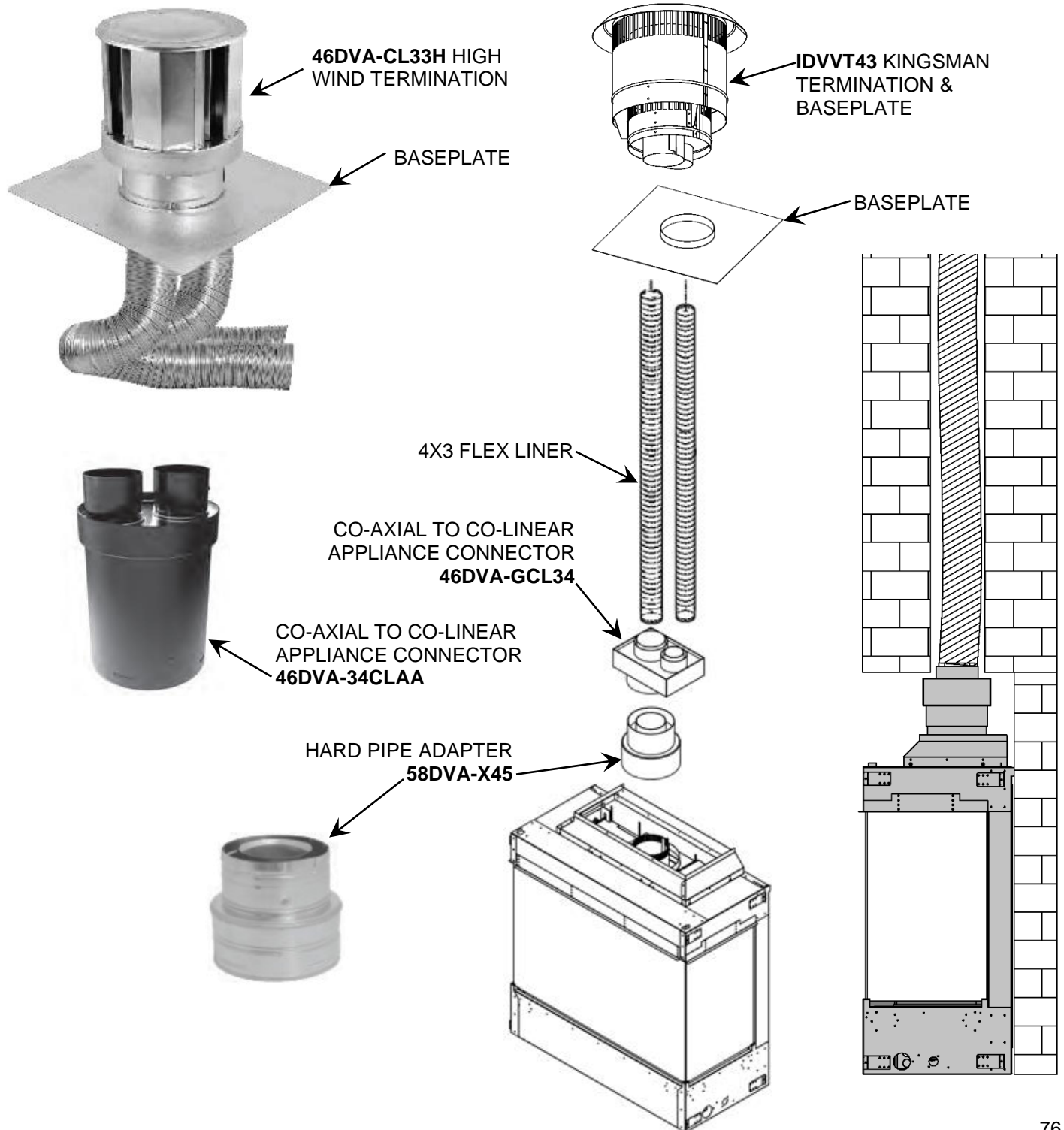

Approved for Power Vent PVH58 / PVH58FM

- This appliance is approved for use with Kingsman Horizontal Power Vents -

A Horizontal Power Vent Termination is intended for use where standard venting configurations are not possible. **Refer to Power Vent Manual for proper installation and use.**

- **NOTE:** MODELS EQUIPPED WITH MILLIVOLT/ STANDING PILOT IGNITION: Downward vertical vent runs are **NOT** permitted.
- **NOTE:** MODELS EQUIPPED WITH INTERMITTENT PILOT IGNITION (Proflame 1 or Proflame 2): Downward vertical vent runs are permitted, however, Cold Climate Switch (Standing Pilot Mode) must **NOT** be used.

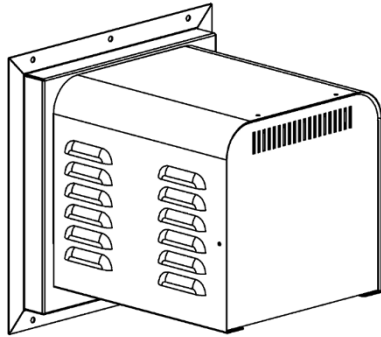

PVH58

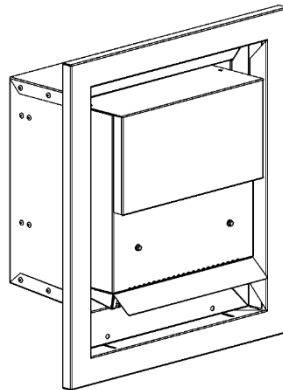

PVH58FM



MQZCVBG34 - Maximum & Minimum Vent Lengths using Power Vents:

- **Minimum Vent Length** is 4 FT vertical x 6 FT horizontal with up to 5 elbows.
- **Maximum Vent Length for 5/8 Flex Pipe** is 7FT vertical x 125FT horizontal with up to 5 elbows.
- **Maximum Vent Length for 5/8 Hard Pipe** is 8FT vertical x 125FT horizontal with up to 8 elbows.

Units Can be Reduced to 3 x 5" or 4 x 6-5/8" Venting (A 12 Inch Length of 5/8 M&G Duravent Pipe Must be Connected to Fireplace Flue First.)

3 x 5" Venting:

- PVA5835- Pipe Reducer for Fireplace
- PVA3558- Pipe Increaser for Termination

4 x 6-5/8" Venting:

- ZDVDRA- Pipe Reducer for Fireplace
- ZDVDIA- Pipe Increaser for Termination



At Fireplace Flue:
 PVA5835 for 3 x 5" Venting
 ZDVDRA for 4 x 6-5/8" Venting



For Power Vent Termination:
 PVA3558 for 3 x 5" Venting
 ZDVDIA for 4 x 6-5/8" Venting

Power Vent Parts List – 5/8 Venting

| NUMBER | DESCRIPTION |
|--------|-------------|
|--------|-------------|

| | |
|-------|--|
| PVH58 | Horizontal Power Vent Starter Kit - Exterior Mount |
|-------|--|

| | |
|---------|---|
| PVH58FM | Horizontal Power Vent Kit - Flush Mount |
|---------|---|

Note: Must use a one foot section of 5/8 DV hard pipe to connect to the Power Vent Termination (not supplied)

CHOOSE CONTROL MODULE OR HARNESS DEPENDENT ON VALVE SYSTEM

| | |
|---------|--|
| PVC58MV | Power Vent Control Module - for Millivolt Models |
|---------|--|

| | |
|----------|---|
| PVC58IPI | Power Vent Control Module - for Proflame 1 - IPI Models |
|----------|---|

| | |
|---------|--|
| 584-X12 | Harness for Proflame 2 IPI - Deluxe Models |
|---------|--|

| | |
|--------|---|
| PVH20H | Main Wiring Harness Assembly – Extension Harness (20ft) |
|--------|---|

CHOOSE VENTING TO BE USED: SECTION 1: 5/8 HARD PIPE - SECTION 2: 3/5" HARD PIPE - SECTION 3: 4x6-5/8" HARD PIPE - SECTION 4: FLEX VENT

SECTION 1 DIRECT VENT HARD PIPE 5/8" – Used for entire installation – Order Z58DFA

| | |
|--------|--|
| Z58DFA | Duravent Hard Pipe Adapter – 5/8" (Sloped Flue) Note: Only sloped flues require Z58DFA adapter. |
|--------|--|

SECTION 2 DIRECT VENT HARD PIPE 3/5"- Used for entire installation- Order PVA5835, PVA3558

| | |
|---------|---|
| PVA5835 | Duravent REDUCER- 5/8" to 3/5" ADAPTER (used at flue of fireplace) (Requires a one-foot section of MG Hard Pipe at flue before using PVA5835) |
|---------|---|

| | |
|---------|------------------------|
| PVA3558 | Termination End |
|---------|------------------------|

| | |
|--|--|
| | Duravent Pipe Increaser- at Power Vent |
|--|--|

SECTION 3 DIRECT VENT HARD PIPE 4 x 6-5/8" - Used for entire installation- Order ZDVDRA, ZDVDIA

| | |
|-------|---|
| ZDVRA | Duravent REDUCER- 5/8" to 4x6-5/8" ADAPTER (used at flue of fireplace) (<i>Requires a one-foot section of MG Hard Pipe at flue before using ZDVDRA</i>) |
|-------|---|

| | |
|--|------------------------|
| | Termination End |
|--|------------------------|

| | |
|--------|--|
| ZDVDIA | Duravent Pipe Increaser- at Power Vent |
|--------|--|

SECTION 4 FLEX VENT – Used for entire installation – order Z58PVA

Note: Must use a one-foot section of 5/8 DV hard pipe (not supplied) to connect to the Power Vent Termination.

| | |
|--------|---|
| Z58PVA | Flex Pipe Adapter Kit - (to adapt flex pipe to power vent to hard pipe) |
|--------|---|

FLEX VENTING KITS

| | |
|--------|---|
| Z58FK5 | Flex Kit (5" & 8" Dia.) x 2.5' (Unexpanded) 5' Expanded |
|--------|---|

| | |
|--------|---|
| Z58FK8 | Flex Kit (5" & 8" Dia.) x 4' (Unexpanded) 8' Expanded |
|--------|---|

| | |
|---------|--|
| Z58FK20 | Flex Kit (5" & 8" Dia.) x 10' (Unexpanded) 20' Expanded *Kits are complete with spring stand-offs & silicone. |
|---------|--|

POWER VENT ACCESSORIES

| | |
|--------|----------------------------|
| ZDV5FC | Flex Connector 5" Diameter |
|--------|----------------------------|

| | |
|--------|----------------------------|
| ZDV8FC | Flex Connector 8" Diameter |
|--------|----------------------------|

| | |
|---------|---------------|
| ZDV5FCL | Flex Clamp 5" |
|---------|---------------|

| | |
|---------|---------------|
| ZDV8FCL | Flex Clamp 8" |
|---------|---------------|

| | |
|--------|---------------------------|
| ZDV4SS | Spring 4" Standoff Spacer |
|--------|---------------------------|

| | |
|---------|-----------------------------|
| PVH58WT | Wall Thimble for Power Vent |
|---------|-----------------------------|

Part No. Description

Fireplaces

MQZCVBG34NE2 Heater Rated Fireplace, NG, Ceramic Glass, Low E Tempered Glass Safety Barrier, Proflame 2 IPI System, Remote Control, Halogen Lights

MQZCVBG34LPE2 Heater Rated Fireplace, Propane, Ceramic Glass, Low E Tempered Glass Safety Barrier, Proflame 2 IPI System, Remote Control, Halogen Lights

Optional Corner Kit

ZCV34BGCK Corner Kit- Can be installed at either end of fireplace.

Enclosure Grills

V34EG Enclosure Grill, 4-3/8"H x 32-5/16"W, 3 louver grill (ready to paint)

V34EGS Enclosure Side Grills [Qty 2] (ready to paint) 6" H x 11-1/4" W, 6 louver grills (ready to paint)

Optional Accessories

34ZCVBG-TLK Tile Lip Kit

Reflective Glass Liners

MQZCVBG34RGB Glass Back Liner

MQZCVBG34RGE Glass Side Liner

Refractory Liners

MQZCVBG34RLTB Traditional Back Liner

MQZCVBG34RLTE Traditional Side Liner

MQZCVBG34RLFB Fluted Back Liner

MQZCVBG34RLFE Fluted Side Liner

Media Options

WARNING: DO NOT OPERATE THIS APPLIANCE WITHOUT DECORATIVE GLASS EMBERS ON BURNER AND MEDIA TRAY

MQG5W Decorative Glass 1/2" White 5LB

MQG5A Decorative Ember Glass Cobalt Blue 5LB

MQG5B Decorative Ember Glass – Black 5LB

MQG5ZG Decorative Glass- Zircon Glacier Ice 5LB

MQG5C Decorative Glass Bronze 5LB

MQROCK2 Rock Set Natural

MQROCK3 Rock Set Multi-Color

MQSTONE Decorative Stones

MQEMBER Glowing Embers

RBCB1 Cannonballs- Assorted size and colors

MQLOGF453 Driftwood Log Set – 5 pc. Set

MQRBD3 Driftwood Log Set – 5 pc. Set

MQRBRW Birchwood Log Set - 5 pc. Set

MQ42D Driftwood Log Set – 5 pc. Set

MQLOGF34BW Birchwood Log Set

MQLOGF34OAK Oak Log Set

Safety Barrier Glass

34ZCVBG-315 Low E Tempered Glass Safety Barrier [1 pc] Front

34ZCVBG -319 Low E Tempered Glass Safety Barrier [2 pcs] Sides

Firebox Glass & Gasket

34ZCV-310 Ceramic Front Glass - 27-1/2" x 23-1/8" No Gasket Required –

34ZCVBG-311 Ceramic Side Glass- 9-11/16" x 23-1/4"

48VL-020 Gasket for Firebox Glass

Replacement Burner Assembly / Burner

34ZCVBG-200A Fireplace Burner

34ZCVBG-BLPE2 Proflame 2 Burner Assembly- Propane c/w Valve System

34ZCVBG-BNE2 Proflame 2 Burner Assembly- Natural Gas c/w Valve System

Conversion Kits

34ZCVBG-CKLP2 Proflame 2 LP Conversion Kit

34ZCVBG-CKNG2 Proflame 2 NG Conversion Kit

Valve Systems

1005-P002SI SIT Proflame 2 Valve Nova LP

1005-P001SI SIT Proflame 2 Valve Nova NG

Pilot Assemblies

1002-P047SI SIT IPI Pilot Assembly LP

1002-P033SI SIT IPI Pilot Assembly NG

Miscellaneous Parts

1000-150GE Silicone GE Red IS806 #736

1000-150MP Hi-Temp Millpac Sealant 840099

1000-255 Orifice Brass - (State Size)

FP15GC Stainless Steel Gas Connector

Optional Thermostats and Remote Controls

GTMFL Remote Control Transmitter- PF2 - 584.090 - WiFi Version

RCP2WIFI **WI-FI Dongle and Harness Kit - for Proflame 2 Appliances** (Control your fireplace with your smartphone - App required)

WMBH Wall Mount - Battery Backup Holder Kit
 - c/w 16 FT Harness - PF1/2
 (Convenient and accessible location for
 Battery Backup for IPI Systems)

Horizontal Vent Termination, Wall
 Thimble, 60" Flex Pipe, Screws, Mill
 Pac.

Electrical Components

34ZCV-P77912 Lamp Halogen c/w 48" lead wires

Replacement Bulb 10W 12V 64418 or Sylvania 58691
 (Lightbulbs not covered under Warranty)

3927ZDV-P601 Halogen Solid State Transformer
 12V 60W

Kingsman Fireplace Venting

Z58VT Vertical Vent Termination

Z58HT Horizontal Vent Termination

FDVHSCU Safety Cage for Horizontal
 Termination

Z58AIS Attic Insulation Shield

Z58AIS24 Attic Insulation Shield

ZDVVOS Offset Support

Z58FS Firestop Spacer

Z58RS Roof Support

Z58GP36 Galvanized Pipe 5" and 8" Dia. x 36"
 (Vertical Installations)

Z58SS Siding Shield

Z58WT Wall Thimble (Horizontal Venting)

Z58WTS Horizontal Wall Thimble Shield (For
 Low Enclosures)

ZDVSS Siding Shield for FDVHT

Z58SSLR Siding Shield - Large Return

Z58GP Galvanized Pipe 8" Dia. x 48"
 (Vertical Installations)

Z58MIS60 Mylar Insulation Sleeve 8" x 5ft

Z58AAF Flashing 8" c/w Storm Collar (1/12 to
 7/12)

Z58AF2 Flashing 8" c/w Storm Collar (8/12 to
 12/12)

Z58AF3 Flashing 8" c/w Storm Collar Flat

ZDV8SC Storm Collar 8"

Z58FK5 Flex Kit (5" & 8" Dia.) x 2.5'
 (Unexpanded)
 5' Expanded

Z58FK8 Flex Kit (5" & 8" Dia.) x 4'
 (Unexpanded)
 8' Expanded

Z58FK20 Flex Kit (5" & 8" Dia.) x 10'
 (Unexpanded) 20' Expanded *Kits are
 complete with spring stand-offs &
 silicone.

Z58HSK5 Horizontal Round Termination Vent
 Starter Kit - 5/8" X 5 FT Length, Wall
 Thimble Shield,

| | |
|---------|----------------------------|
| ZDV5FC | Flex Connector 5" Diameter |
| ZDV8FC | Flex Connector 8" Diameter |
| ZDV5FCL | Flex Clamp 5" |
| ZDV8FCL | Flex Clamp 8" |
| ZDV4SS | Spring 4" Standoff Spacer |



LIMITED LIFETIME WARRANTY

This Limited Lifetime Warranty applies only while the unit remains at the site of the original installation and only if the unit is installed inside the continental United States, Alaska, Hawaii, and Canada. The warranty applies only if the unit is installed and operated in accordance with the printed instructions and in compliance with applicable installation and building codes and good trade practices.

BASIC ONE YEAR WARRANTY

During the first year after installation of the appliance, we will provide a replacement for any component part of your unit found to be defective in materials or workmanship, including labour costs. Repair work requires prior approval by Kingsman, labour costs are based on a predetermined rate schedule and any repair work must be done through an authorized Kingsman dealer.

(Excluded Components: Accent Light Bulbs, Gasketing, Glass Fronts, and Paint)

LIMITED LIFETIME WARRANTY

The heat exchanger, combustion chamber and burner of every Kingsman product excluding the Outdoor Firepit are warranted against materials or workmanship during the period the product is owned by the original owner. The part to be replaced must be returned to our distributor in exchange for the replacement part. Any labor, material, freight and/or handling charges associated with any repair or replacement pursuant to this Limited Lifetime Warranty will not be covered by this warranty.

GENERAL TERMS

In lieu of providing a replacement part, we may, at our option, provide the distributor's component purchase price from us or a credit equal to the distributor's component purchase price from us toward the purchase of any new unit which we distribute. If a credit is given in lieu of a replacement part, the rating plate from the unit being replaced must be submitted on a warranty claim, and the unit being replaced must be made available to our distributor for disposition.

In establishing the date of installation for any purpose, including determination of the starting date for the term of this Limited Lifetime Warranty, reasonable proof of the original installation date must be presented*, otherwise the effective date will be based upon the date of manufacture plus thirty (30) days.

We will not be responsible for and you, the user, will pay for: (a) damages caused by accident, abuse, negligence, misuse, riot, fire, flood, or Acts of God (b) damages caused by operating the unit where there is a corrosive atmosphere containing chlorine, fluorine, or any other damaging chemicals (other than in a normal residential environment) (c) damages caused by any unauthorized alteration or repair of the unit affecting its stability or performance (d) damages caused by improper matching or application of the unit or the unit's components (e) damages caused by failing to provide proper maintenance and service to the unit (f) any expenses incurred for erecting, disconnecting or dismantling the unit (g) parts or supplies used in connection with service or maintenance (h) damage repairs, inoperation or inefficiency resulting from faulty installation or application (i) electricity or fuel costs or any increase in electricity or fuel cost whatsoever including additional or unusual use of supplemental electric heat.

We shall not be liable for any incidental, consequential, or special damages or expenses in connection with any use or failure of this unit. We have not made and do not make any representation or warranty of fitness for a particular use or purpose, and there is no implied condition of fitness for a particular use or purpose. We make no express warranties except as stated in this Limited Lifetime Warranty. No one is authorized to change this Limited Lifetime Warranty or to create for us any other obligation or liability in connections with this unit. Any implied warranties shall last for one year after the original installation. Some states and provinces do not allow the exclusion or limitation of incidental or consequential damages or do not allow limitations on how long an implied warranty or condition lasts, so the above limitations or exclusions may not apply to you. The provisions of this limited warranty are in additions to and not a modification of or subtraction from any statutory warranties and other rights and remedies provided by law.

Save this certificate. It gives you specific legal rights, and you may also have other rights which may vary from state to state and province to province.

In the event your unit needs servicing, contact your dealer or contractor who installed or serviced your unit. When requesting service, please have the model and serial number from each unit readily available. If your dealer needs assistance, the distributor is available for support and we, in turn support the distributor's efforts.

Fill in the installation date and model and serial numbers of the unit in the space provided below and retain this limited warranty for your files.

Model No. _____ Serial No. _____ Date installed _____

Dealer or Contractor Name: _____

*To receive advantage of your warranty, you must retain the original records that can establish the installation date of your unit.