

# FLARE

## FIREPLACES

**WARNING:** If the information in these instructions is not followed exactly, a fire or explosion may result in causing property damage, personal injury, or loss of life.

Do not store or use gasoline or other flammable vapors or liquids in the vicinity of this or any other appliance.

If you smell gas, please:

- Do not try to light any appliance
- Do not touch any electrical switch; do not use any phone in your building.
- Immediately call your gas supplier from a neighbor's phone. Follow the gas supplier's instructions.
- If you cannot reach your gas supplier, call the fire department.

A qualified installer, service agency, or local gas supplier must perform installation and service.

## DANGER



**HOT GLASS WILL CAUSE BURNS.**

**DO NOT TOUCH GLASS UNTIL COOLED**

**NEVER ALLOW CHILDREN TO TOUCH GLASS**



Flare requires installation be performed by an NFI certified installer, or an authorized Flare Dealer Tech who has been trained to professionally install the fireplace. Installations that do not follow this instruction will not be covered by warranty or service.

## NOTICE

**INSTALLER:** Leave this manual with the appliance.

**CONSUMER:** Retain this manual for future reference.

**Installation and service of this appliance must be performed by qualified NFI certified technician, or a certified and trained Flare Fireplaces dealer.**

**Massachusetts:** The piping and final gas connection must be performed by a licensed plumber or gas fitter in the state of Massachusetts. Also, see local code for carbon monoxide requirements.

Flare Fireplaces SIT ProFlame II – CS7

[Flare Front Facing, See-Through, Left Corner, Right Corner, Double Corner, Room Definer, Passage]  
Version 20.5

# FLARE FIREPLACES

## CONTENTS

SAFETY INFO AND WARNINGS.....	7
FLARE FIREPLACES – FRAMELESS IN EVERY WAY .....	9
CSA CERTIFICATION.....	9
MANUAL MODEL LIST AND INFORMATION .....	10
ELECTRICAL AND POWER REQUIREMENTS.....	12
FIREPLACE OPERATION .....	12
REMOTE CONTROL – INSTRUCTIONS.....	12
TEMPERATURE INDICATION DISPLAY .....	13
TURNING THE SYSTEM ON .....	14
FLAME HEIGHT CONTROL.....	15
SMART THERMOSTAT MODE .....	16
MANUAL THERMOSTAT MODE.....	17
CONTINUOUS PILOT AND INTERMITTENT PILOT IGNITION (IPI AND CPI) .....	18
KEY LOCK – CHILD SAFETY MODE .....	19
LOW BATTERY DETECTION .....	20
PAIRING YOUR REMOTE TO THE SIT RECEIVER .....	21
IGNITION SEQUENCE .....	22
WALL SWITCH CONTROL .....	23
MEDIA PLACEMENT GUIDE AND CALCULATION GUIDE.....	24
REFLECTIVE BACK, DOUBLE GLASS, AND SAFETY SCREEN INSTALLATION .....	25
LOCATING GLASS PACK.....	25
REFLECTIVE BACK – INSTALLATION.....	26
INNER CERAMIC GLASS – INSTALLATION.....	27
OUTER TEMPERED GLASS – INSTALLATION.....	31
SAFETY SCREEN – INSTALLATION .....	33
INSTALLATION STEPS .....	34
ACCESS PANEL .....	35
ACCESS - COMPONENT WHIP.....	35
ACCESS PANEL SIZING RECOMENDATIONS .....	36
INSTALLATION PREPARATION.....	37
FIREPLACE UNPACKING .....	37

# FLARE

## FIREPLACES

---

TELESCOPIC LEG SETUP.....	41
FRONT FACING AND SEE-THROUGH FIREPLACE LEG SETUP .....	42
LEFT, RIGHT, AND DOUBLE CORNER FIREPLACE LEG SETUP .....	43
UNPACKING CONTROL UNIT AND ACCESSORIES .....	44
POSITIONING AND SECURING YOUR FIREPLACE .....	45
RGB LED LIGHTING .....	46
PAIRING YOUR RGB LED REMOTE - GEN 1 AND GEN 2.....	48
RGB LED REMOTE PAIRING.....	49
GEN 1 REMOTE PAIRING .....	49
GEN 1 REMOTE UNPAIRING .....	49
GEN 2 REMOTE PAIRING .....	49
CONNECTING LIGHTS DIRECTLY TO FIREPLACE .....	50
RGB LIGHT VERIFICATION – PRE-INSTALL .....	51
OPTIONAL BLOWER KIT – SCREEN UNITS ONLY .....	52
VENTING PIPE .....	53
VENT PIPE SIZE USED ON EACH FIREPLACE .....	54
VENT PIPE - CLEARANCES .....	54
DIRECT VENT PIPE CUT-OUT DIMENSIONS.....	55
VERTICAL TERMINATIONS .....	56
MULTIPLE VERTICAL TERMINATIONS .....	57
HORIZONTAL TERMINATIONS .....	58
MULTIPLE HORIZONTAL TERMINATIONS .....	58
VENT TERMINATION CLEARANCES.....	59
VENT RESTRICTOR SETUP .....	60
SIGNS A VENT RESTRICTOR ADJUSTMENT IS NEEDED .....	60
ADJUSTING AIR SHUTTER .....	61
CHIMNEY PATH PLANNING AND INSTALLATION .....	62
FLARE 30R/30H/PASSAGE.....	63
FLARE 45R/45H/45EH .....	64
FLARE 50R/50H/50EH .....	65
FLARE 60R/60H/60EH .....	66
FLARE 70R/70H/70EH .....	67
FLARE 80R/80H/80EH .....	68

# FLARE

## FIREPLACES

---

FLARE 100/100H/100EH .....	69
POWER VENTING.....	70
ELECTRICAL CONNECTION TO THE POWER VENT SYSTEM.....	72
POWER VENT BOARD ELECTRICAL WIRING DRAWING .....	73
GAS REQUIREMENTS.....	75
SIT PROFLAME II GAS VALVE LAYOUT .....	76
USING A REDUCER TO DE-RATE YOUR FLARE FIREPLACE .....	77
ADDING THE FLARE FIREPLACES DE-RATING REDUCER.....	78
ORIFICE SIZE .....	79
GAS VALVE ACCESS DOOR .....	79
LIQUID PROPANE USAGE IN A FLARE FIREPLACE .....	80
COMMONWEALTH OF MASSACHUSETTS.....	81
TELEVISION MOUNTING ABOVE THE FIREPLACE.....	83
TV INSTALL – FLAT EXAMPLE .....	84
TV INSTALL – RECESSED WITH FIREPLACE OVERHANG.....	85
45-DEGREE ELBOW ON TOP OF FIREPLACE TO MAINTAIN CLEARANCE TO RECESS.....	86
TV INSTALL – NO RECESS WITH MANTEL.....	88
FRAMING SPECIFICATIONS .....	89
METAL FRAMING .....	89
WOOD FRAMING .....	90
FIREPLACE CLEARANCES .....	91
NON-COMBUSTIBLE MATERIALS SPECIFICATIONS.....	100
CLEARANCE TO A SPRINKLER.....	101
HEAT RELEASE AND AIR INTAKE SPECIFICATION .....	102
HEAT RELEASES .....	102
HEAT RELEASE EXAMPLES .....	103
DROP WALL .....	103
SHADOW LINE.....	103
LINEAR SLOT OR LOUVERED GRATE.....	104
AIR INTAKE.....	105
DOUBLE GLASS REQUIRED AIR INTAKE EXAMPLES .....	106
FLOATING HEARTH .....	106
TOE-KICK REVEAL .....	107



# FLARE FIREPLACES

---

LEFT AND RIGHT-SIDE VENTS .....	108
LINEAR SLOT .....	109
FLARE FRONT, SEE THROUGH, AND CORNER FIREPLACE CLEARANCE .....	110
FLAT – SIDE AND ISOMETRIC VIEW & CLEARANCES .....	110
L SHAPE – SIDE AND ISOMETRIC VIEW .....	113
SIDE OVERHANG FOR LEFT, RIGHT, AND DOUBLE CORNER FIREPLACES.....	116
INDOOR/ OUTDOOR KIT.....	117
OUTDOOR KIT INSTALLATION CONSIDERATIONS.....	117
OUTDOOR KIT OVERHANG REQUIREMENTS .....	118
OUTDOOR KIT FRAMING AND FINISH .....	119
OUTDOOR KIT CLEARANCE TO NON-COMBUSTIBLE WALL .....	119
OUTDOOR KIT OPENING DIMENSIONS .....	120
WEATHER-PROOF YOUR OUTDOOR KIT CAVITY.....	121
FIREPLACE BURNER DIMENSIONS .....	121
HOME AUTOMATION.....	122
ELECTRIC AND CONTROL .....	123
ELECTRIC DIAGRAM - SCREEN .....	123
SIT PROFLAME II DIAGRAM – DOUBLE GLASS AND POWER VENT .....	124
DOUBLE GLASS BOARD & LED LIGHT GUIDE .....	125
ELECTRICAL DIAGRAM - POWER VENT SYSTEM .....	126
REPLACEMENT PARTS .....	127
MAINTENANCE .....	128
GLASS MAINTENANCE .....	129
PILOT MAINTENANCE .....	129
BURNER MAINTENANCE.....	130
VENT MAINTENANCE.....	130
DOUBLE GLASS FANS MAINTENANCE .....	131
MAINTENANCE LOG.....	132
WARRANTY POLICY .....	133
18 MONTH COMPREHENSIVE WARRANTY .....	133
LIMITED 5 YEAR COVERAGE .....	133
LIMITED 10 YEAR COVERAGE .....	134
CONDITIONS.....	134

# FLARE FIREPLACES

---

EXCLUSIONS .....	135
WARRANTY VOID WHEN.....	135

# FLARE

## FIREPLACES

### SAFETY INFO AND WARNINGS

## WARNING!

If the information in these instructions is not followed exactly, a fire or explosion may result causing property damage, personal injury, or loss of life. A qualified installer, service agency or the supplier must perform installation and services.

The direct vent system appliance must be installed as an OEM installation in manufactured homes (USA only), or an aftermarket permanently located, or a mobile home, where not prohibited by local codes, and must be installed in accordance with Manufacturer's instructions and the Manufactured Home Construction and Safety Standard, Title 24 CFR, Part 3280, in the United States, or the Standard for Installation in Mobile Homes, CAN/ CSA Z240 MH Series, in Canada.

This appliance is only for use with the type(s) of gas indicated on the rating plate. A conversion kit is supplied with the appliance.

This product is listed to the ANSI standards for ANSI A21.50b-2009 / CSA 2.22b-2009 Vented Gas Fireplaces CAN/ CGA 2.17-M91 Gas-Fired Appliance for use at high altitudes.

NEVER LEAVE CHILDREN OR ANY OTHER AT-RISK INDIVIDUAL ALONE WITH THE APPLIANCE.

## WARNING!

Proposition 65 Warning: Fuels used in gas, wood burning or oil-fired appliances, and the products of combustion of such fuels, contain chemicals known to the State of California to cause cancer, birth defects and other reproductive harm. California Health & Safety Code Sec. 25249.6. In the State of Massachusetts, only a licensed plumber and gas fitter may install this product. See Note for the Commonwealth of Massachusetts.

Due to elevated temperatures, the appliance should be located out of traffic and away from furniture and draperies. Children and adults should be alerted to the hazards of high surface temperature and should stay away to avoid burns or clothing ignition.

Young children should be carefully supervised when they are in the same room as the appliance. Toddlers, young children, and others may be susceptible to accidental contact burns. A physical barrier is recommended if there are at-risk individuals in the house. To restrict access to a fireplace or stove, install an adjustable safety gate to keep toddlers, young children, and other at-risk individuals out of the room and away from hot surfaces.

# FLARE

## FIREPLACES

This appliance must be electrically wired and grounded in accordance with local codes, or in the absence of local codes, with National Electric Code ANSI/NFPA 70 – latest edition or the Canadian Electric Code CSA C22.1

A 110-120V AC Circuit for this product must be protected with ground-fault circuit-interrupter protection, in compliance with the applicable electrical codes, when it is installed in locations such as bathrooms or near sinks.

When an existing Category I heater is removed or replaced, the original venting system may no longer be sized to properly vent the attached appliances. Instructions shall also indicate effects of an improperly sized venting system (formation of condensate, leakage, spillage, etc.) and shall specify the following test procedure.



### **WARNING CARBON MONOXIDE POISONING WARNING**

Failure to follow the steps below for each appliance connected to the venting system being placed into operation could result in carbon monoxide poisoning or death. The following steps shall be followed for each appliance connected to the venting system being placed into operation, while all other appliances connected to the venting system are not in operation:

1. Seal any unused openings in the venting system.
2. Inspect the venting system for proper size and horizontal pitch, as required in the National Fuel Gas Code, ANSI Z223.1/NFPA 54 or the Natural Gas and Propane Installation Code, CSA B149.1 and these instructions. Determine that there is no blockage or restriction, leakage, corrosion, and other deficiencies which could cause an unsafe condition.
3. As far as practical, close all building doors and windows, and all doors between the spaces in which the appliance(s) connected to the venting system are located and other spaces of the building.
4. Close all fireplace dampers.
5. Turn on clothes dryers and any appliance not connected to the venting system. Turn on any exhaust fans, such as range hoods and bathroom exhausts, so they are operating at maximum speed. Do not operate a summer exhaust fan.
6. Follow the lighting instructions. Place the appliance being inspected into operation, and adjust the thermostat so appliance is operating continuously.
7. Test for spillage from draft hood equipped appliances at the draft hood relief opening after five minutes of main burner operation. Use the flame of a match or candle.
8. If improper venting is observed during any of these above tests, the venting system must be corrected in accordance with the National Fuel Gas Code, ANSI Z223.1/NFPA and/or Natural Gas and Propane Installation Code, CSA B149.1.
9. After it has been determined that each appliance connected to the venting system properly vents when evaluated as outlined above, return doors, windows, exhaust fans, fireplace dampers and any other gas-fired burning appliance to their previous conditions of use.

# FLARE FIREPLACES

## FLARE FIREPLACES – FRAMELESS IN EVERY WAY

Flare Fireplaces are where innovation, quality and luxury come together to form innovative ideas. By combining superior raw materials, contemporary design, creative technology, and a frameless way of thinking, we have created a full line of direct-vent fireplaces that are luxurious, simple to operate, and efficient. Our modern gas fireplaces are distinguished by their clean linear design, superior built quality, and unique features.

## CSA CERTIFICATION

All our fireplaces are evaluated and have been certified to meet stringent CSA guidelines, ensuring optimum quality, safety, and efficiency, as well as been certified and evaluated to work with Natural Gas or Liquid Propane.

**Certification Information:** [CSA File # 263124](#)

CSA/ANSI Z21.88-2019 • CSA 2.33-2019- Vented Gas Fireplace Heaters

**CSA Classes:** CLASS 2901 84 / CLASS 2901 04

All fireplaces are rated for commercial and residential use.



### The CSA Mark

The Canadian Standards Association (CSA) is a nonprofit association serving business, industry, government and consumers in Canada and the global marketplace. Among many other activities, CSA develops standards that enhance public safety. A Nationally Recognized Testing Laboratory, CSA is familiar with U.S. requirements. **According to OSHA regulations, the CSA-US Mark qualifies as an alternative to the UL Mark.**

**Here are some areas where CSA standards are applied:**

- Canadian Electrical Code, Part III-Outside Wiring
- Electrical Engineering Standards
- Electromagnetic Compatibility

# FLARE FIREPLACES

## MANUAL MODEL LIST AND INFORMATION

All models share the same gas valve system, remote, gas connection, and glass type, simplifying installation and operation. All warnings and instructions apply to all models. Refer to the model's name for specific model, clearance, and installation information.

- Flare Front 30 - 100 ": 16" (R), 24" (H), 30" (EH)
- See-Through 30 - 100 ": 16" (R), 24" (H), 30" (EH)
- Left Corner 30 - 100 ": 16" (R), 24" (H), 30" (EH)
- Right Corner 30 - 100 ": 16" (R), 24" (H), 30" (EH)
- Double Corner 30 - 100 ": 16" (R), 24" (H), 30" (EH)
- Flare Room Definer 45 - 100": 16" (R), 24" (H), 30" (EH)

**Flare Fireplaces should only be connected to M&G DuraVent or ICC 4x6 or 5x8 venting system.** Refer to the specific appliance model and size to determine vent size and chimney pathway requirements. For detailed chimney installation information please use the following manuals:

[DuraVent Pro Installation](#)

[DuraVent Direct Vent Pro Concentric Flex](#)

- DuraVent Direct Vent Pro Concentric Flex pipe is only approved for vertical implementation, and up and out applications with up to 2' of horizontal to the termination to prevent sagging. Mixing rigid and flex is also acceptable.

*Ex: Flare Fireplaces sized 30-70" may go up 3' using the concentric DuraFlex, turn 900-degrees, then terminate horizontally. Please note Flare Fireplaces sized 80-100" require 6' minimum rise before their first elbow/bend.*

[ICC Pro Installation](#)

This product is listed to ANSI standards for "Vented Gas Fireplace Heaters" and applicable sections of "Gas Burning Heating Appliances for Manufactured Homes and Recreational Vehicles", and "Gas Fired Appliances for Use at High Altitudes". Installation **MUST** comply with local, regional, state, and national codes and regulations. Consult insurance carrier, local building inspector, fire officials or authorities that have authority over restrictions, installation inspection and permits

# FLARE

## FIREPLACES

This installation must conform to local codes. In the absence of local codes, you must comply with the National Fuel Gas Code, ANSI Z223.1 -latest edition in the USA and the CAN/CGA B149 Installation Codes in Canada.

Improper installation, adjustment, alteration, service, or maintenance can cause injury or property damage. For assistance or additional information, consult a qualified service technician, service agency or your local fireplace dealer.



Flare Fireplaces requires installation be performed by an NFI certified installer, or certified Flare dealer. Installations that do not follow this instruction will not be covered or serviceable under warranty.

# FLARE

## FIREPLACES

### ELECTRICAL AND POWER REQUIREMENTS

**Screen Unit:** 110V, 15A Outlet (Dedicated circuit is optional but recommended) or directly wired. When using an outlet, make sure the outlet is accessible in the event of servicing.

**\*\*** 110V, 15A additional power source needed if Optional RGB-LEDs are included in unit.

**Double Glass:** 110V, 15A Outlet (Dedicated circuit is optional but recommended) or directly wired. When using an outlet, make sure the outlet is accessible in the event of servicing.

**\*\*** No additional power source needed for optional RGB-LEDs.

### FIREPLACE OPERATION

Every indoor Flare Fireplace ship with a remote control and wall switch to operate the fireplace and its features. **These two items do not work in parallel with one another, so if you turn the fireplace on with one it must also be turned off with that same option.** \*Home automation is also available by removing the included wall switch and replacing it with a low voltage close-contact relay which can be tied into a new or existing home automation system or smart device.

\* Flare Fireplaces does not recommend the use of home automation with our fireplaces. Only operate the fireplace when you can be in the same room as the high-powered gas appliance.

### REMOTE CONTROL – INSTRUCTIONS

The SIT ProFlame II system ships with an easy-to-use four-button remote control. It requires three AAA batteries and has a 0-50°C ambient temperature rating with a 315MHz radio frequency.

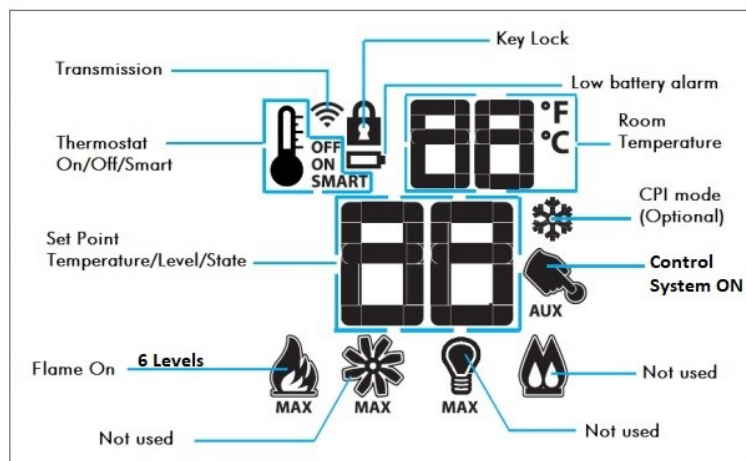



# FLARE FIREPLACES

---

## TEMPERATURE INDICATION DISPLAY

When the system is turned off the LCD screen will display the current room temperature in Fahrenheit (°F) or in Celsius (°C.).

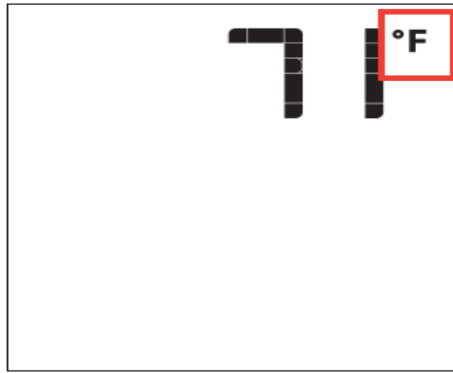
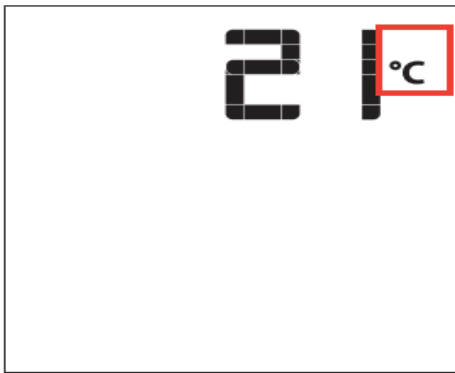

To change from in Fahrenheit (°F) to Celsius (°C.), or vice versa, press the **“Thermostat”** key and the **“Mode”** key at the same time.

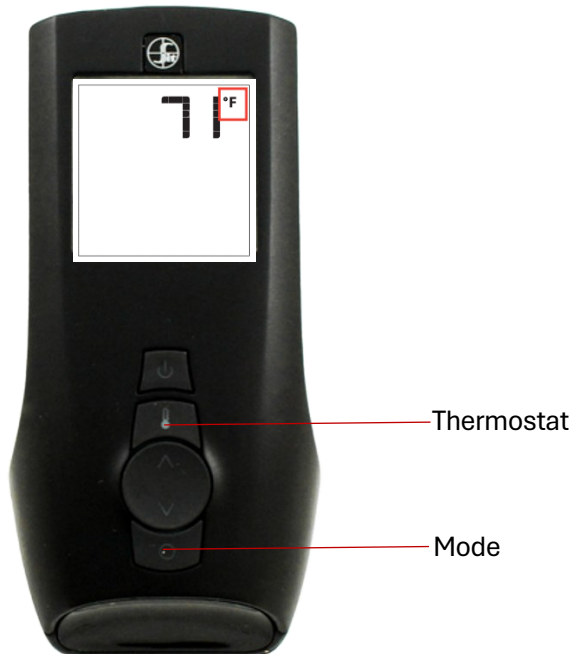

# FLARE FIREPLACES

---

## TURNING THE SYSTEM ON

When in “On” mode the remote LCD will show the room temperature icon, and any other modes currently turned on by default.

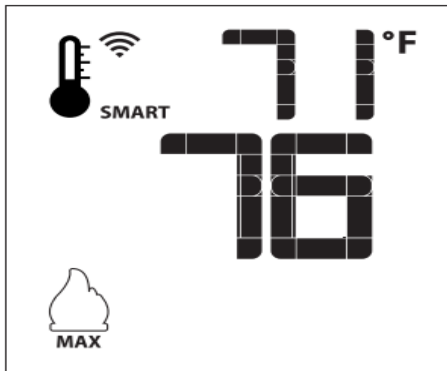

To turn “On” press the On/Off remote button. The remote LCD will then show other icons. At that time, the module will activate the appliance and a single beep from the receiver will confirm command from the remote.



# FLARE

## FIREPLACES

### FLAME HEIGHT CONTROL

ProFlame II has 6 levels of modulation. When the system is On the flame level will be at the maximum level. Once adjusted the remote LCD will show a series of 6 steps going down, or up, depending on adjustments being made.

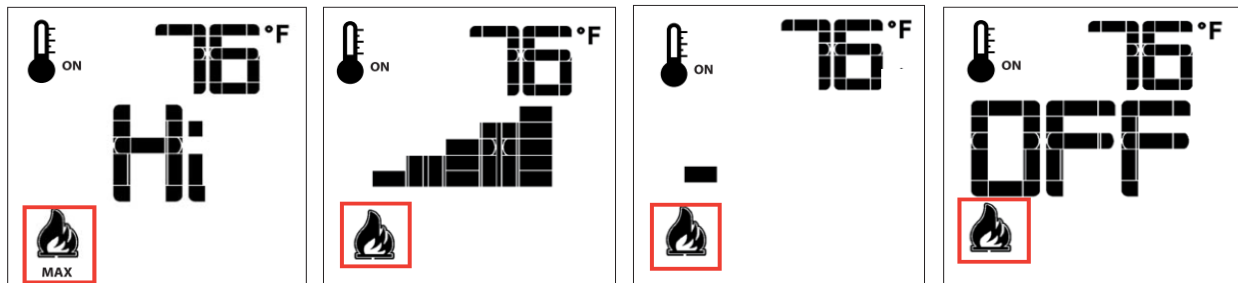

By pressing the “Down” key once it will reduce the flame height by one step. Continued pressing of the down arrow will result in the unit turning off. To return to normal fireplace operation use the “Up” key to increase the flame height to high. If the “Up” has been pressed while the system is ON, but the flame is OFF the flame will come ON in the high position.



# FLARE FIREPLACES

---

## SMART THERMOSTAT MODE

The smart thermostat mode will adjust the flame height depending on the set temperature that has been set by the user. When the room temperature gets close to the set temperature the smart thermostat function will modulate the flame down.

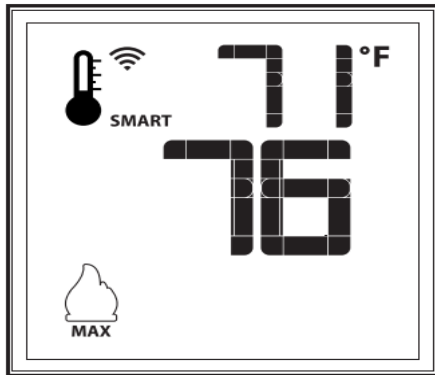

To activate the smart thermostat function, press the **“Thermostat”** key while the appliance is on until the word SMART appears beside the icon of the thermostat. To adjust the set temperature, press the **“Up”** or **“Down”** arrow keys until the desired temperature is displayed on the LCD.



# FLARE FIREPLACES

---

## MANUAL THERMOSTAT MODE

The Remote control can operate as a room thermostat. The thermostat can be set to a desired temperature to control the room temperature. The thermostat icon on the LCD screen will display the thermostat status is ON. The user can then set a suitable temperature for the space.

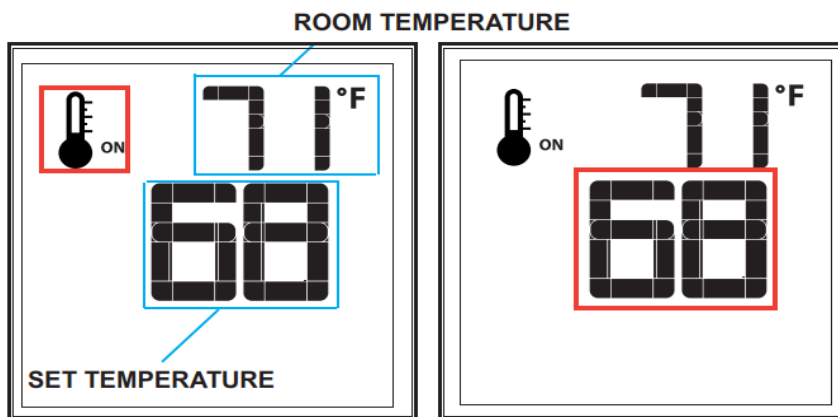

To activate this option, press the “**Thermostat**” key. To adjust the desired temperature, use the “**Up**” or “**Down**” until the desired temperature is displayed on the remote LCD screen.

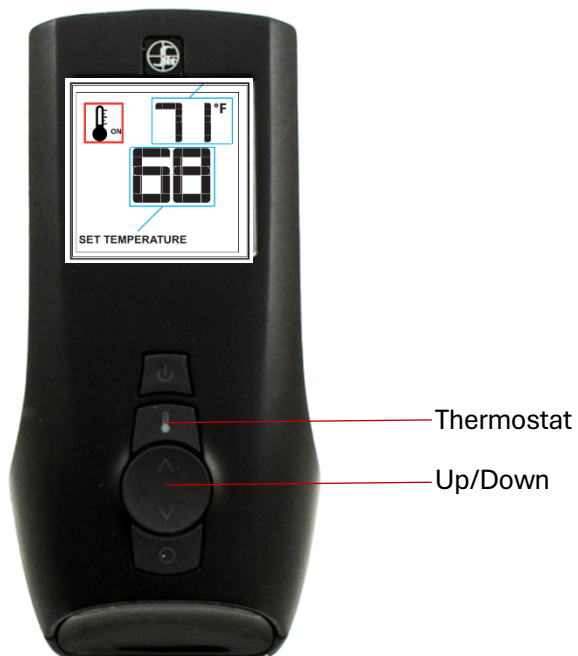

# FLARE FIREPLACES

---

## CONTINUOUS PILOT AND INTERMITTENT PILOT IGNITION (IPI AND CPI)

By default, the Flare Fireplace is setup for IPI operation, but this can be changed to CPI **on screen units only**.

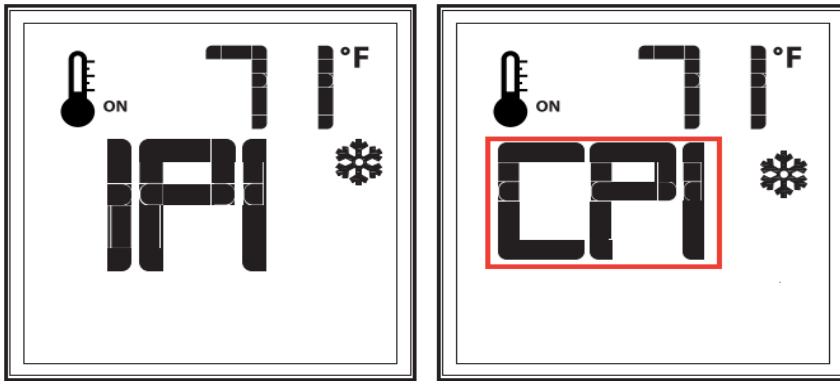

When the system is Off pressing the “**Mode**” key to index to CPI mode icon. Pressing the “**Up**” arrow will select the **CPI** mode *(but it is still not activated. See instructions at link above)*



[For detailed instructions on how to change from IPI to CPI please click here.](#)

# FLARE FIREPLACES

---

## KEY LOCK – CHILD SAFETY MODE

To avoid unsupervised operation of the remote control this feature has been created. A lock icon will appear on the LCD screen.

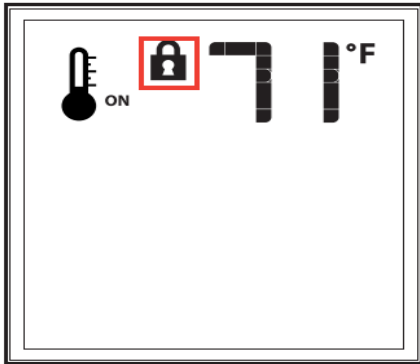

To activate this feature, press the **“Mode”** and **“Up”** at the same time. A lock icon will appear in the LCD screen. To deactivate this feature, press **“Mode”** and **“Up”** at the same time.



# FLARE FIREPLACES

---

## LOW BATTERY DETECTION

The lifespan of your remotes three AAA batteries varies based on remote and fireplace operation. When the remote battery is low an empty battery icon will appear on the LCD Screen

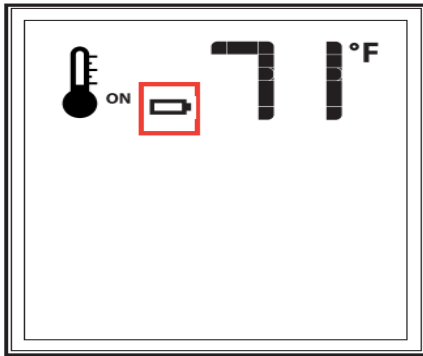

## WARNING

Do not use a screwdriver or other metallic object to remove the batteries from the battery box! This could cause a short circuit to the system.



# FLARE FIREPLACES

## PAIRING YOUR REMOTE TO THE SIT RECEIVER

Your remote will come paired with the fireplace receiver to allow for operation out of the box. In the event of a remote or receiver replacement, or power failure, use the following procedure to pair the remote with the receiver. First, install 3 AAA batteries in the remote battery bay located on the remote back. Next, press the SW1 button on the module see the following figure, the module will beep 3 times to indicate that it is ready to synchronize with the remote. Finally, press the ON/OFF button in the remote, the module will beep 4 times to indicate that the remote and the module are synchronized to each other.

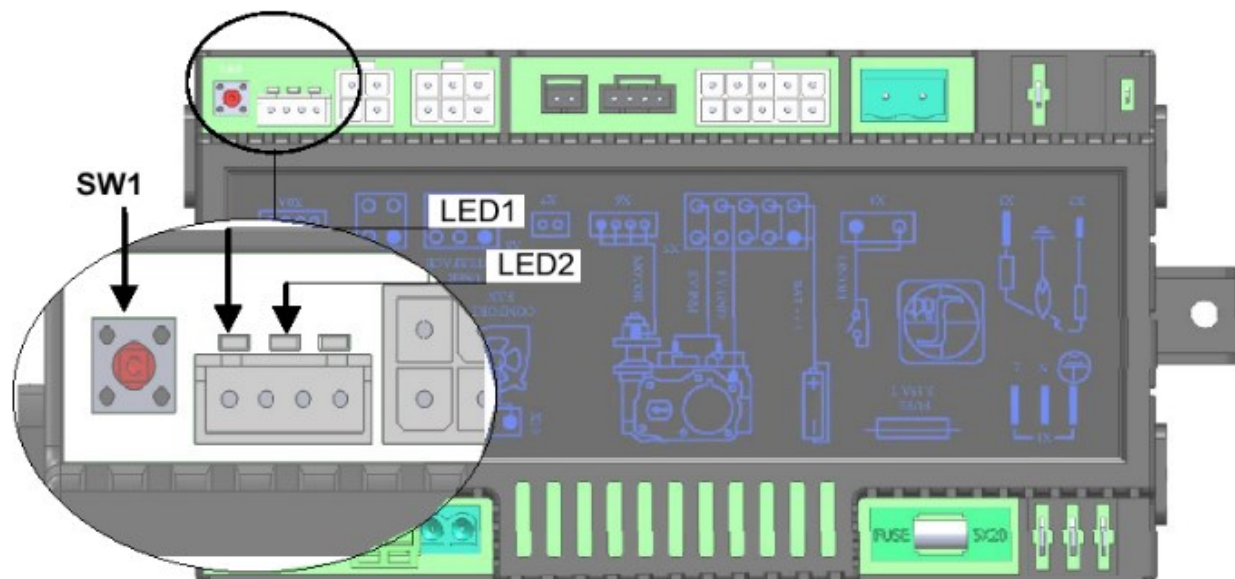

**SW1 = Programing Button**

# FLARE FIREPLACES

---

## IGNITION SEQUENCE

Starting from Off, press the remote power button. Four seconds after it is pushed the SIT module will send a spark to the pilot hood, and spark for 60 seconds. If there is no flame ignition during the first ignition sequence, the SIT module will stop sparking for approximately 35 seconds and then begin sparking again. The second attempt will spark for 60 seconds. If there is no positive ignition after the second sequence the SIT module will go into a Lock Out and the LED Indicator Light will blink three times in intervals until the system is reset.

**Reset Using the Transmitter ON/OFF power button:** Turn the system off by pressing the remote power button. After approximately 2 seconds press it again

**Low Battery Condition (<4V) Remote Control:** Battery icon will appear on LCD remote control display. Replace batteries.

**Low Battery Condition (<4V) Battery Backup:** Red LED Indicator will blink (1) time in intervals. Low double-beep emitted from SIT control module when it receives an ON/OFF command from the remote control. Replace Batteries.

**Pilot Flame Error Condition:** Red LED Indicator will blink (2) times in intervals. Contact your dealer if this occurs.

**System Lock Out Condition:** Red LED Indicator will blink (3) times in intervals. Make sure gas is turned on and sensor is not shorted. Follow **Reset Using the Transmitter ON/OFF power button** instructions above.

# FLARE

## FIREPLACES

---

### WALL SWITCH CONTROL

The SIT ProFlame II system ships with an easy-to-use wall switch which operates the On/Off functionality only. It can be used in the event the remote control isn't nearby or has no battery charge. The wall switch comes connected to the X8 port on the SIT receiver.

### NOTICE

When used with double glass, power vented, and summer kit systems, the wall switch must be connected to operate the relay necessary to turn the secondary fan system on, verify power, and allow ignition. Also, the wall switch does not work together with the remote. If you turn on the unit with the wall switch, it must also be turned off using the wall switch to prevent syncing and ignition issues with your system.



# FLARE FIREPLACES

## MEDIA PLACEMENT GUIDE AND CALCULATION GUIDE

Every Flare fireplace can be set up with approved glass, stone, or wood media. Quantities are determined by the size of the fireplace and type of media chosen within that fireplace. Mixing of media types (i.e., glass and stones together) is acceptable if the quantities are adjusted to prevent overwhelming the burner and gas flow. To achieve a balance between the ideal appearance and operation the following guidelines have been set to create an optimum overall presentation. Stepping outside of these recommendations will lead to excess sooting, uneven gas flow, and degraded flame presentation.

Media Calculation Guide

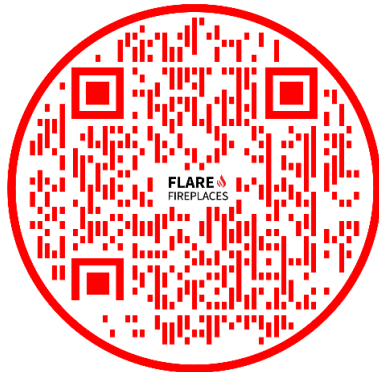

Media Placement Guide

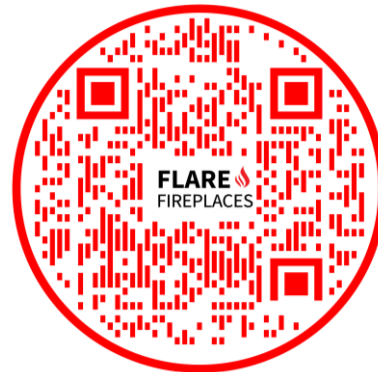

## NOTICE FOR ALL MEDIA TYPES

- Maintain a 1" clearance on all sides of the pilot cover to prevent continuity issues with ignition.
- Do not install media in quantities that exceed the recommendations in the media calculation guide.
- Do not use media to block or cover burner ports.
- Keep all media within the fireplace burner tray.
- Do not place media between the inner glass and external safety barrier.
- Media cannot be smaller than ¼"
- Keep all media types in a single layer over the burner to prevent poor flame presentation, excess sooting, and overheating.

## WARNING!

**CHOKING HAZARD!** Ensure that the fireplace area is clear of fire glass particles as these could be ingested by small children. Vacuum area after installation.

# FLARE FIREPLACES

## REFLECTIVE BACK, DOUBLE GLASS, AND SAFETY SCREEN INSTALLATION

The following outlines how to install your Reflective Back, Double Glass, and Safety Screen, which can ship with a Flare fireplace. To see a step-by-step video on this installation, [please click here](#).

**FOR A STEP BY STEP VIDEO OF THIS PROCESS  
PLEASE SCAN THE QR CODE BELOW**

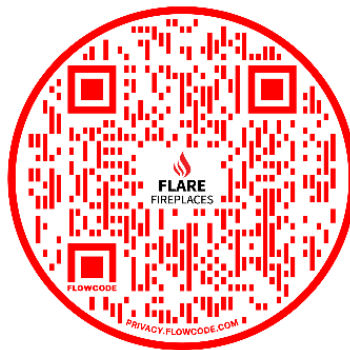

## LOCATING GLASS PACK

A Flare fireplace will come with its glass pre-packaged safely, inside the fireplace crate, attached to the interior frame using 4 screws. Removing these screws allows you to pull the glass packet away from the crate. Store this glass packet in a safe location until you are ready to install the glass panels.



# FLARE FIREPLACES

## REFLECTIVE BACK – INSTALLATION

Your black reflective back panel will be installed against the back wall of the fireplace using two suction cups, secured by the included reflective back brackets, and behind the outside lip of the burner tray along the base of the fireplace. See examples outlined in the steps and images below.

Using suction cups, lift your reflective back into position against the back wall of your fireplace, making sure to set behind the lower lip of the burner tray.

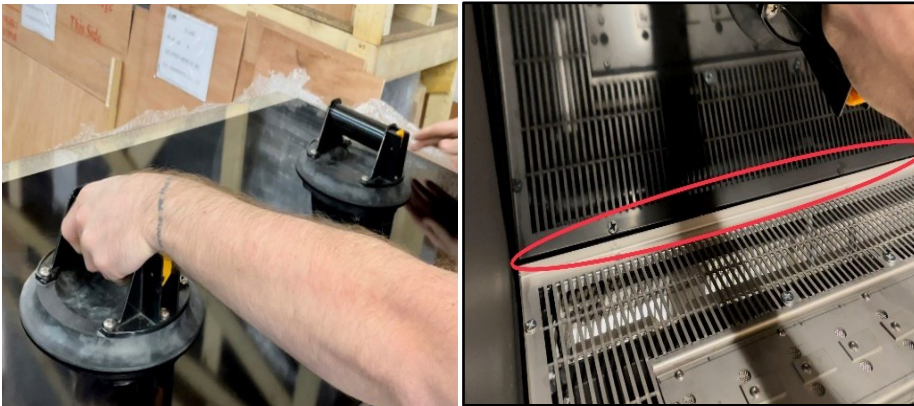

Using your handheld power drill, attach your reflective back holders over your glass by securing the included screw(s) into the back panel of the fireplace. Take care to not overtighten your bracket screw to protect against unwanted glass breakage. You want to have some give so the glass can flex with the fireplace temperature changes.





# FLARE FIREPLACES

## INNER CERAMIC GLASS – INSTALLATION

Your inner ceramic glass panel can be installed after removing the left, right, and bottom fillers. Then remove the left, right, and bottom trim brackets. Followed by opening the top butterfly trim to allow the installer to insert the glass into position. See examples outlined in the steps and images below.

Remove the left and right magnetic fillers by gently lifting and pulling them out. Next, lift out the bottom filler piece(s). This will reveal the trim brackets used to hold your inner ceramic glass in position.



# FLARE FIREPLACES

---

Remove the left, right, and bottom inner trim brackets by loosening the bolts or hand screws, releasing the trim brackets from the fireplace frame. Set aside to protect from damage.

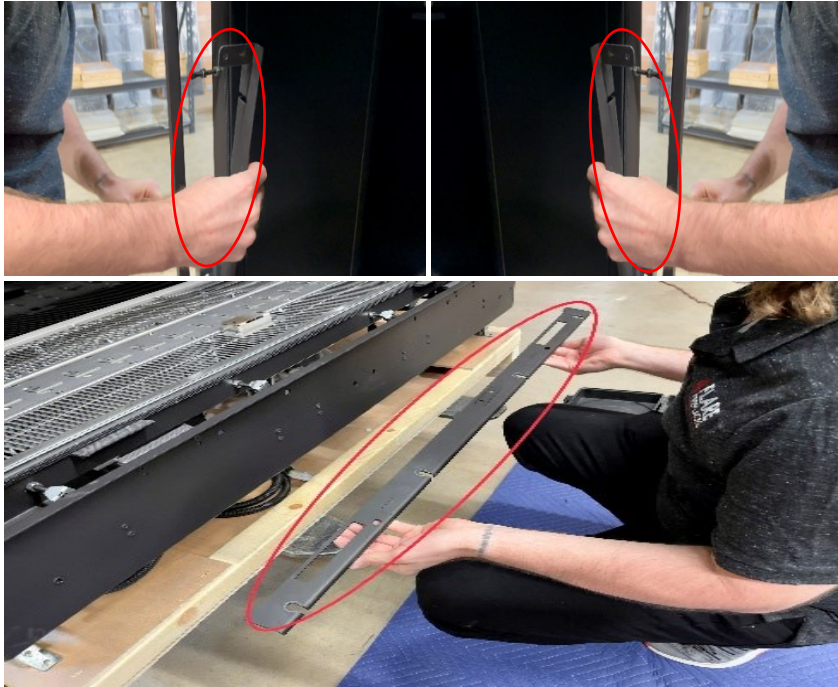

Locate and loosen all hand screws across the top frame of the fireplace. This will open your inner butterfly trim.

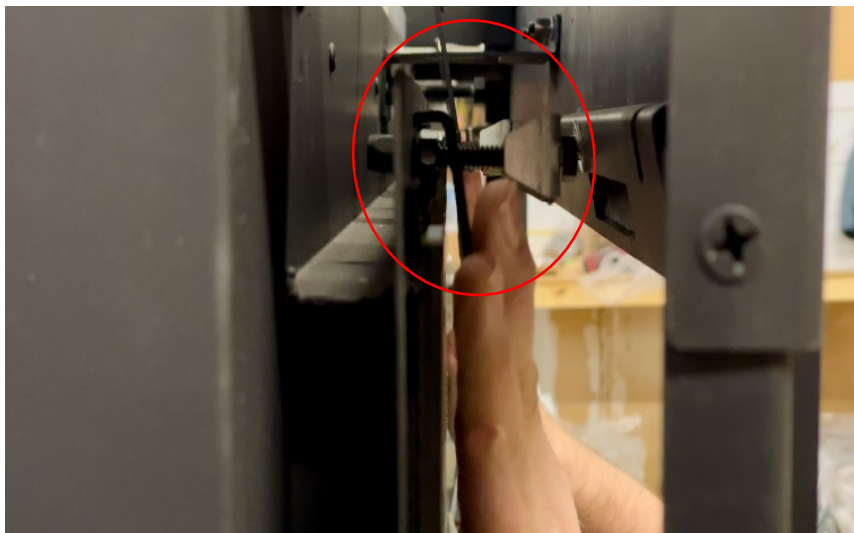



# FLARE

## FIREPLACES

---

Using suction cups insert the inner ceramic glass behind the upper butterfly trim, push in gently, then set panel along the small holders, lining the bottom frame of the fireplace.



Once the inner ceramic glass panel is in position press in and hold the upper butterfly trim while tightening the hand screws, sealing the glass against the non-combustible gasket.



# FLARE FIREPLACES

---

Locate and reinstall your lower trim bracket. Once in position tighten all the hand screws securing your lower trim bracket against the glass, sealing it against the non-combustible gasket.

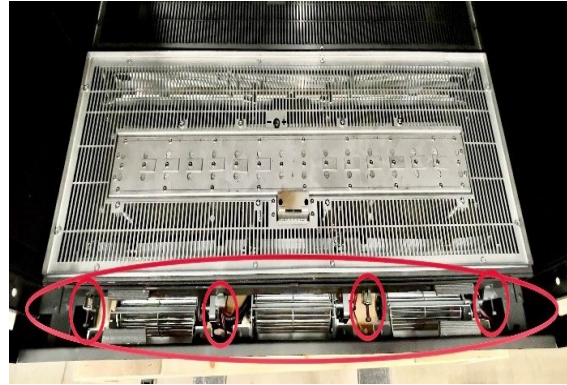

Locate and reinstall your lower louvered filler by placing it on its holder across the bottom frame of the fireplace.



# FLARE FIREPLACES

Locate and reinstall your left and right-side magnetic fillers to complete your inner ceramic glass installation.



## OUTER TEMPERED GLASS – INSTALLATION

Your outer tempered glass panel can be installed only after the inner ceramic glass has been properly placed into position. See examples outlined in the steps and images below.

Using suction cups lift your tempered layer of glass safely into position, gently placing the top of the glass against the outside of the top butterfly trim tabs

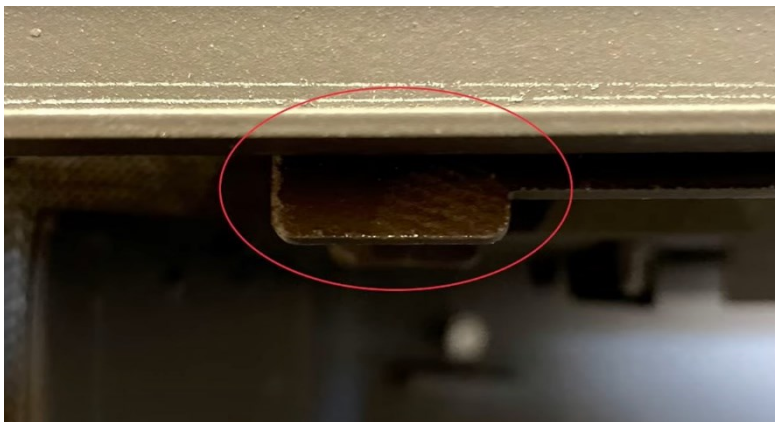

# FLARE

## FIREPLACES

---

Using the top of your glass panel, gently push in on the tabs, sliding your glass up and into the channel built into the top of the fireplace frame.



Once lifted into the top of the fireplace frame, make sure the bottom of your glass has clearance to the bottom fireplace frame and slowly lean glass inward to insert into bottom glass channel.





# FLARE FIREPLACES

## SAFETY SCREEN – INSTALLATION

The Instructions outlined below show how to install the invisible mesh safety screen on all Flare fireplaces. This safety barrier can be installed and removed with no tools.

### NOTICE

The screen safety barrier is designed to reduce the risk of burns from the hot viewing glass and is provided with this appliance unless the unit has been upgraded to include the Double Glass. The invisible mesh screen must remain installed for the protection of children and other at-risk individuals. Do not operate the fireplace without the safety screen barrier.

Using the frame of your screen, gently press against the exposed butterfly trim tabs across the top of the fireplace, pushing in and lifting into position placing the screen in front of the butterfly trim which holds it tight against the inner face.



Gently lean the bottom of the screen frame in and set down within inner screen channel



# FLARE FIREPLACES

## INSTALLATION STEPS

Prior to starting the installation, make sure you read and understand all the WARNING information in the manual. Do not start the installation if you are unclear about any of the installation related subjects.

### Determine the following:

- The vent system configuration to be used based on the fireplace location. Follow the manual venting section to determine the venting requirements and setting.

**NOTE:** Make sure the vent requirements are supported by the Flare manual and installation instruction, as requirements are model size specific.

- Clearance requirements from combustible and non-combustible materials. Follow the clearance instructions and example in the manual.

**NOTE:** Clearance instructions and examples are model specific

- Gas supply piping.
- Confirm if the fireplace is going to operate using Natural Gas (NG) or Propane. Use the attached product label to confirm the fireplace is set for the expected gas type.
- Electrical wiring requirements.
- Framing and finishing details.

1. Unpack the fireplace box, adjust telescopic legs and place in the upright position.
2. Put the Fireplace in the desired location, verifying proper clearances have been met.
3. For units equipped with RGB LED lights, connect and test light system.
4. Attach the fireplace to the back wall or framing using top brackets at each corner.
5. Adjust fireplace vent restrictor based on venting run and document setting here: (1-6) \_\_\_\_\_
6. Connect vent pipe to adapter on top of the fireplace.
7. Connect gas line and verify pressures, documenting here: (**NG:** 7-8 WC, **LP:** 10-11 WC) \_\_\_\_\_
8. Deration may be required if the installation is over 2000' above sea level.
9. Connect any electrical wiring for Summer Kit, Power Vent, or other additional items.
10. Install and properly arrange all fireplace media. ([Click for Media Placement Guide](#))
11. Verify Ignition
12. Adjust air shutter to achieve proper air : gas ratio.
13. Complete framing and finishing work.

**Do not install it if proper specifications have not been met, or the fireplace and components are damaged.**

# FLARE

## FIREPLACES

### ACCESS PANEL

The Flare Fireplace gas valve and control system is on a component “whip” that can be stretched up to 50” from the middle of the fireplace and placed next to the access door location. **Do not place the gas valve or controls above the level of the burner.** Keep the area storing the fireplace components clean and free of unnecessary debris. If the fireplace sits too low on the floor, the controls must be placed outside the non-combustible zone or insulated from the heat from the fireplace. The access door can be placed on any side of the fireplace, below the non-combustible line. The use of a 10”x10” access door is highly recommended. If no access door is installed, it’s possible to access the gas valve from inside the fireplace by removing the glass. The access door can also be used as a lower air intake (**FOR A DOUBLE GLASS INSTALLATION**) if it’s perforated, and the open air-flow requirements are maintained. The access door can be concealed in many ways, such as HVAC vent cover or removable piece of finishing material attached with magnets or screws to the framing.

### ACCESS - COMPONENT WHIP

All Flare fireplaces ship with the components attached to a 50” whip, centered, at the underside of the fireplace. This allows an installer to drag the components to the far left, far right, behind, below, or directly underneath the fireplace. Opening unlimited possibilities for implementing access based on the unique project parameters and the 50” component whip.

### COMPONENT OVERHANG BASED ON SIZE OF FIREPLACE

30” Fireplace:	35” On left and right side
45” Fireplace:	27.5” On left and right side
50” Fireplace:	25” On left and right side
60” Fireplace:	20” On left and right side
70” Fireplace:	15” On left and right side
80” Fireplace:	10” On left and right side
100” Fireplace:	NO OVERHANG

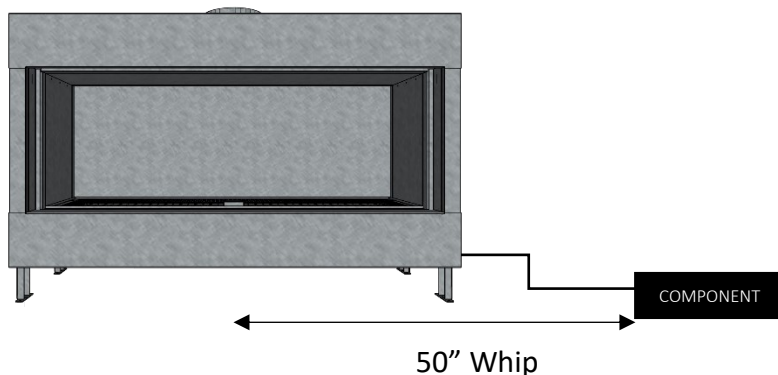

# FLARE

## FIREPLACES

### ACCESS PANEL SIZING RECOMENDATIONS

Access panels will come in all different shapes and sizes, below is minimum sizing for multiple styles outlining what is important for creating meaningful access. Keep in mind the access can be on the front, sides, back, or even under the unit. **These are recommendations, not requirements. Use best judgement for sizing based on the unique design parameters of the project.**

#### Access Panel Styles:

- Removeable piece of finishing material
- Louvered Register
- Door
- Removeable Toe-Kick Reveal

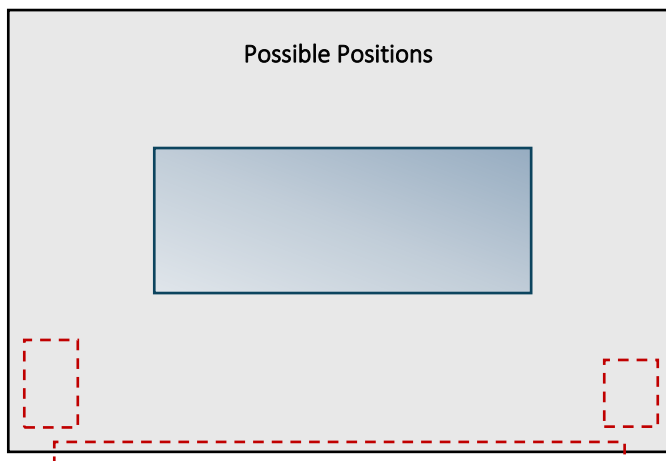
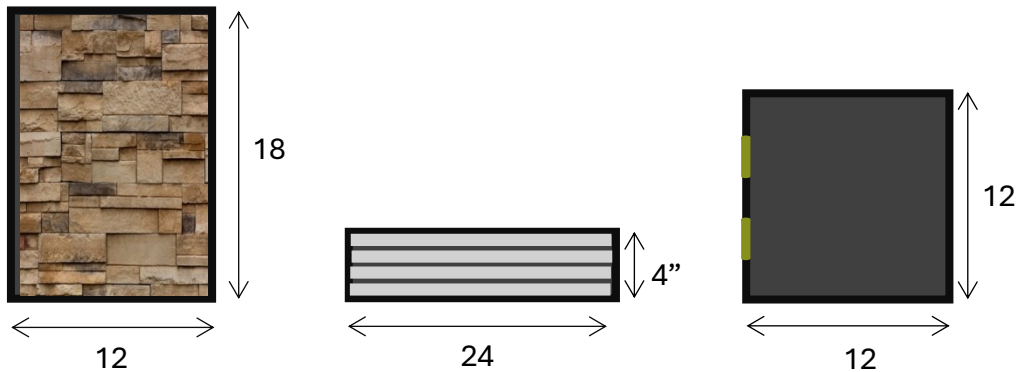



# FLARE FIREPLACES

## INSTALLATION PREPARATION

### FIREPLACE UNPACKING

The following outlines best practices for uncrating and checking in your Flare Fireplace.

Upon delivery verify the fireplace serial number matches your packing slip by locating the fireplace nameplate on the face of your crate. Next, examine the shipment for any damage, making sure to mark any damage found on the Bill of Lading **before your driver leaves**.



## NOTICE

Any damage found after the Bill of Lading is signed and the driver sent on his way may not be covered under warranty. Check-in your fireplaces carefully so we can work together to make sure the transit damage is covered by insurance.

# FLARE FIREPLACES

Using your power drill begin removing the screws on the top and face of the crate to expose the wrapped and protected fireplace inside.



# FLARE FIREPLACES

Once the crate is open use the packing slip to verify everything ordered was successfully delivered. Mark any missing or damaged components on the Bill of Lading **before your driver leaves**.



## NOTICE

If any items from the packing slip are missing from inside the fireplace crate, please call Flare Fireplaces immediately to verify the shipment, as well as any potential resolution.

# FLARE

## FIREPLACES

---

Remove and relocate the glass packet, media, spare parts, and any other immediately unnecessary components to a safe location to not only lighten the load for transit to the jobsite, but to protect these elements from being lost or broken onsite. Please make sure to leave the fireplace, and its electronic components, wrapped until you are ready to install. Protecting them from unnecessary exposure onsite.



# FLARE FIREPLACES

---

## TELESCOPIC LEG SETUP

The fireplace legs will need to be set once the crate has been removed. The legs can be configured so the bottom of the glass will be between 10"-19" above the floor. This means the bottom of the fireplace will be 4"-13" above the floor. Follow the steps below for telescopic legs setup prior to final positioning of the fireplace.

[Telescopic Leg Manual – Minimums and Maximums](#)

[Telescopic Legs Setup Video – Front Facing and See-Through Fireplaces](#)

## NOTICE

Corner style fireplace (Flare-RC/LC/DC/RD) legs will need to be attached to the fireplace, whereas front facing, and see-through styles will come attached from the factory.

## WARNING

Fireplaces must **NOT** be installed without telescopic legs extracted to a minimum of 3". Installing the fireplace without telescopic legs is a fire hazard and may bend the frame causing glass breakage.



# FLARE FIREPLACES

## FRONT FACING AND SEE-THROUGH FIREPLACE LEG SETUP

The following outlines how to adjust your telescopic legs on front facing and see-through fireplaces.

Release the safety pin and two bolts from the leg you are adjusting.

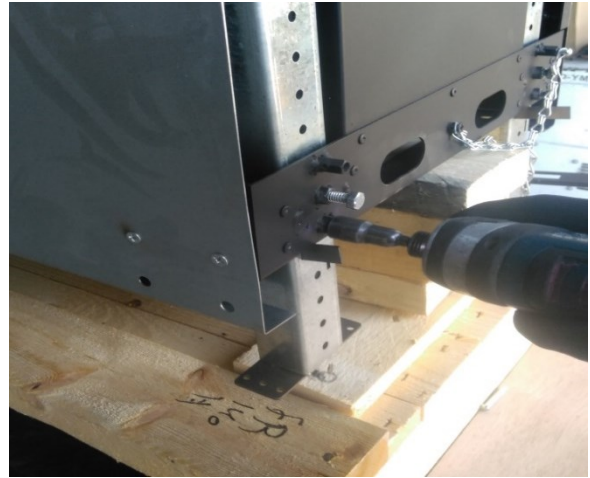

Extend your leg to the desired height, increasing in one-inch increments. Then lock-in your height by reinstalling the two bolts and safety pin. Repeating these steps for all four legs.



\*Add leveling feet if fine-tuned leveling is required to balance your fireplace.

# FLARE FIREPLACES

## LEFT, RIGHT, AND DOUBLE CORNER FIREPLACE LEG SETUP

**Step 1** - First, unpack your corner telescopic legs to verify the four legs and eight screws are present.

**Step 2** - Next, determine which holes to insert the screws so the fireplace will stand at the desired height.

**Step 3** - Attach legs one at a time to each corner using the screws to secure the legs into position.

**Step 4** - Configure remaining legs to the same height.

**Step 5** - Stand the fireplace up and fine tune your feet with the wrench supplied so the fireplace is level. Open the screws to raise the fireplace. Close the screws to lower the fireplace.



## NOTICE

Please note all units must have their telescopic legs attached to achieve the minimum height required to the underside of the fireplace.

# FLARE FIREPLACES

## UNPACKING CONTROL UNIT AND ACCESSORIES

Unpack the accessories (remote, power adapter & wall switch). The gas valve, receiver, control module (for double glass units) **must remain wrapped until the first test of unit.**

- Place accessories (white bag) in a secure location.
- The control unit (gas valve and receiver) is attached to the fireplace on a 50" "umbilical cord".
- Once the fireplace is moved to its final location the control unit can be put close to the service access door.

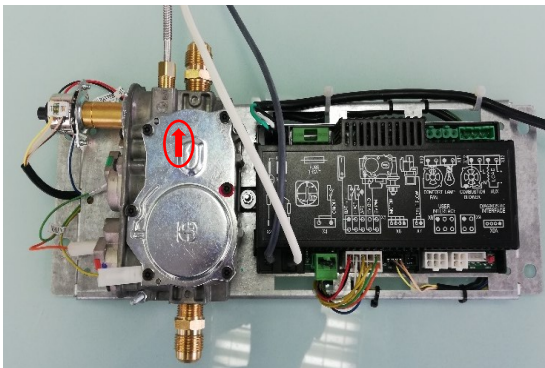



# FLARE FIREPLACES

## POSITIONING AND SECURING YOUR FIREPLACE

Once the telescopic legs have been properly attached and/or adjusted the fireplace can be safely moved, on its delivery pallet, and secured in its final installation location to the back wall or framing using the fireplaces top brackets.

## NOTICE

Make sure to never drag the fireplace during installation. It is recommended to keep the fireplace on its delivery pallet to simplify positioning. The proper clearances and materials for the fireplace surround will need to be verified before attaching the fireplace to the back-wall or framing using the top brackets.



# FLARE

## FIREPLACES

### RGB LED LIGHTING

The Flare Fireplaces RGB LED light kits are the perfect way to showcase your unique style and make a statement inside your Flare Fireplace. The RGB LED light kit open up the possibility of not only designing the space around your fireplace, but the inside your fireplace too. These multi-colored lights are controlled by a touch-screen remote that allows for many different themes, colors, and levels of brightness.

<b>REMOTE</b>	MATERIAL	110x52x20mm
	POWER	AAA Battery *2pcs
	MATERIAL	ABS
	FABRICATION PROCESSING	Multicolor Printing & UV Varnish
	SIZE	85x45x23mm
<b>CONTROLLER</b>	WORKING VOLTAGE	DC12V~24V
	CONTROL WAY	RGB 3 CHANNELS
	MAX LOAD PER CHANNEL	6A
	OUTPUT CONNECTION	COMMON ANODE
	TELECONTROL DISTANCE	30 METERS
	PROGRAMS	20 KINDS

# FLARE

## FIREPLACES

NUMBER	MODE	BRIGHTNESS STATE	SPEED STATE
1	STATIC WHITE	ADJUSTABLE	UNADJUSTABLE
2	WHITE COLOR GRADUAL CHANGES	ADJUSTABLE	ADJUSTABLE
3	ALL COLORS GRADUAL CHANGES	ADJUSTABLE	ADJUSTABLE
4	RED/GREEN/BLUE 3 COLORS GRADUAL CHANGE	ADJUSTABLE	ADJUSTABLE
5	7 COLORS JUMP TO CHANGE	ADJUSTABLE	ADJUSTABLE
6	3 COLORS JUMP TO CHANGE	ADJUSTABLE	ADJUSTABLE
7	RED/GREEN JUMPS TO CHANGE	ADJUSTABLE	ADJUSTABLE
8	REB/BLUE JUMPS TO CHANGE	ADJUSTABLE	ADJUSTABLE
9	BLUE/GREEN JUMPS TO CHANGE	ADJUSTABLE	ADJUSTABLE
10	WHITE COLOR FREQUENTLY BLINKS	ADJUSTABLE	ADJUSTABLE
11	WHITE COLOR GLITTERS	ADJUSTABLE	ADJUSTABLE
12	RED COLOR FREQUENTLY BLINKS	ADJUSTABLE	ADJUSTABLE
13	RED COLOR GLITTERS	ADJUSTABLE	ADJUSTABLE
14	GREEN COLOR FREQUENTLY BLINKS	ADJUSTABLE	ADJUSTABLE
15	GREEN COLOR GLITTERS	ADJUSTABLE	ADJUSTABLE
16	BLUE COLOR FREQUENTLY BLINKS	ADJUSTABLE	ADJUSTABLE
17	BLUE COLOR GLITTERS	ADJUSTABLE	ADJUSTABLE
18	YELLOW COLOR FREQUENTLY BLINKS	ADJUSTABLE	ADJUSTABLE
19	YELLOW COLOR GLITTERS	ADJUSTABLE	ADJUSTABLE
20	CIRCULATION MODE		

# FLARE FIREPLACES

---

## PAIRING YOUR RGB LED REMOTE - GEN 1 AND GEN 2

Use the following instructions to pair your RGB LED remote to your RGB LED Controller in the event the communication between these two items is not functioning

**GEN 1** – No arrow on remote back

[Remote Sync Video](#)



**GEN 2** – With arrow on remote back

[Remote Sync Video](#)



# FLARE

## FIREPLACES

### RGB LED REMOTE PAIRING

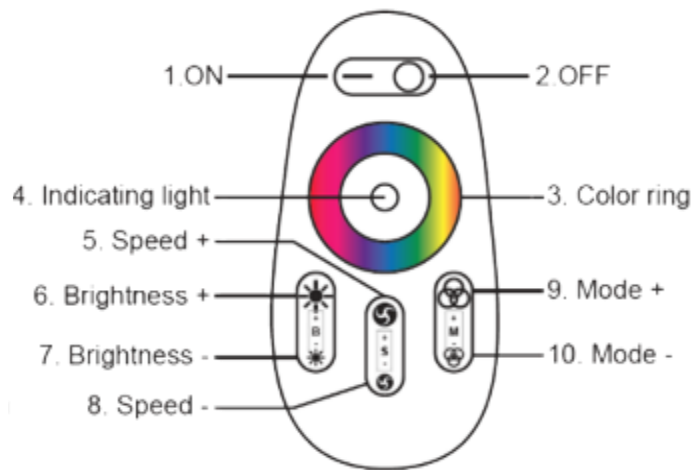

### GEN 1 REMOTE PAIRING

Confirm your components are correctly connected. Remove power to the LED system, then after a short 5 second wait, reconnect power and press the #5 button the moment you see your LED lights in the firebox illuminate. If successful, your LED lights will flash twice.

### GEN 1 REMOTE UNPAIRING

Confirm your components are correctly connected. Remove power to the LED system, then after a short 5 second wait, reconnect power and press the #5 button the moment you see your LED lights in the firebox illuminate. If successful, your LED lights will flash twice.

### GEN 2 REMOTE PAIRING

Confirm your components are correctly connected. Remove power to the LED system, then after a short 5 second wait, reconnect power and press the #1 and #10 buttons simultaneously the moment you see your LED lights in the firebox illuminate. If successful, your LED lights will flash twice.

**\*GEN 2 Remotes have no unpairing process**

# FLARE FIREPLACES

## CONNECTING LIGHTS DIRECTLY TO FIREPLACE

The RGB LED light kit can be directly connected to the SIT Proflame II receiver module, allowing for your lights to be on only when the fireplace is powered on and to control turning the lights On and Off using the SIT Proflame II remote. The control of themes, colors, and brightness are still controlled using the RGB LED Remote, but the built-in memory allows you to set the lights to fit your needs and place the RGB Led remote in a safe location.

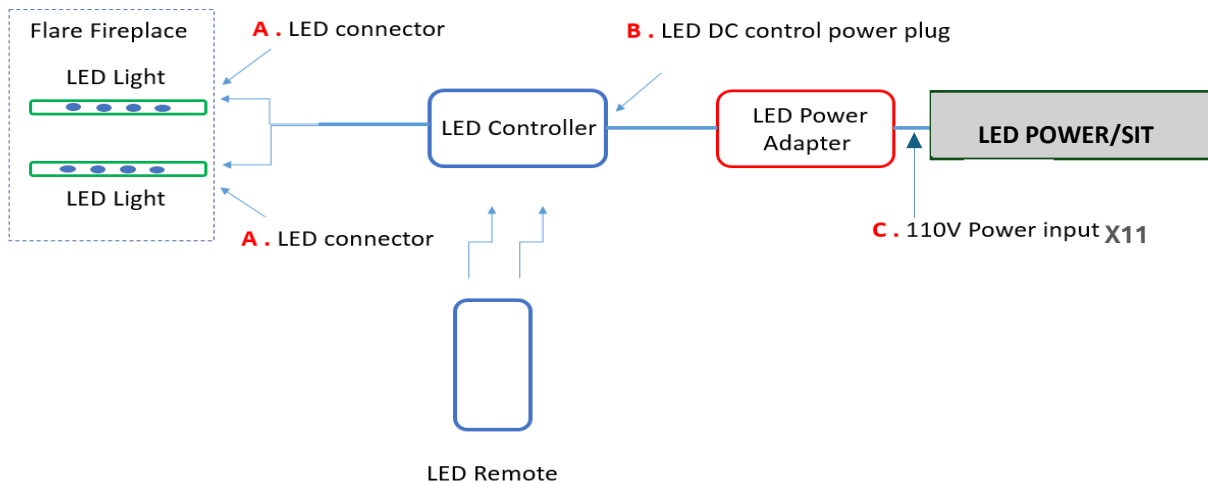
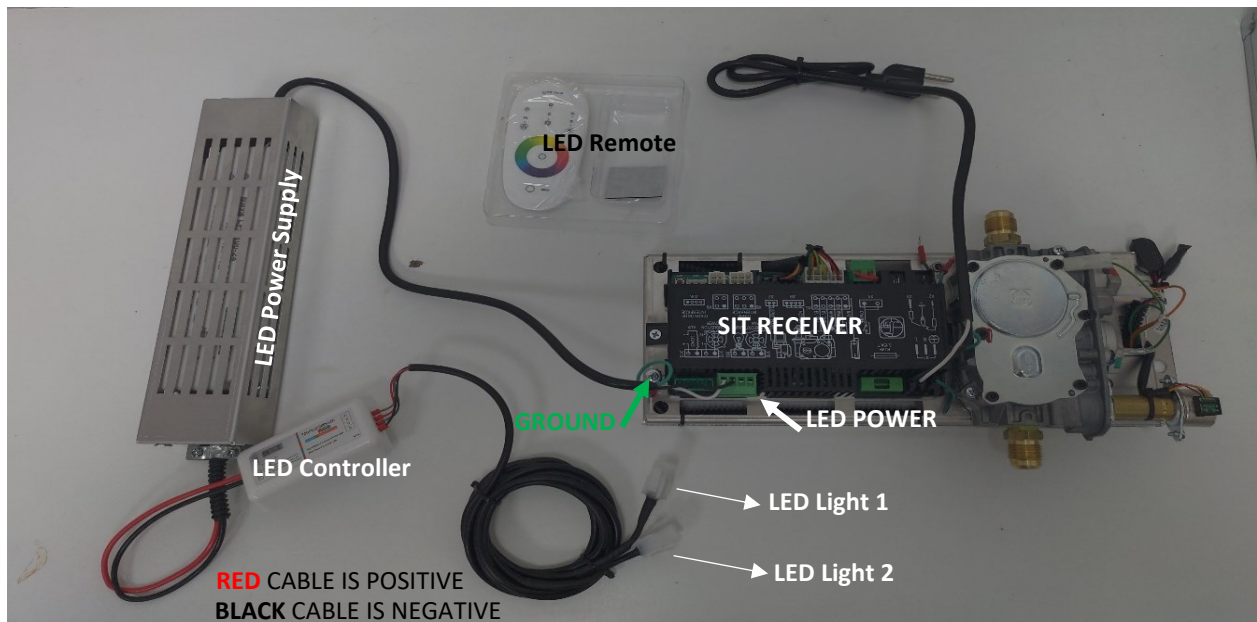

# FLARE FIREPLACES

## RGB LIGHT VERIFICATION – PRE-INSTALL

It is best if LED lights are connected and evaluated during the initial stages of installation to allow easy access to the components (before the wall finishing material is done). Evaluating the LED light requires a 110V power source.

### Testing/Installation steps:

1. Remove all LED components from the shipping bag.
2. Components are pre-connected prior to shipping. Connect LED connectors (points A) to the fireplace using the quick-connect connectors.
3. Connect LED Controller to the LED power supply (point B)
4. Connect LED Power supply to X11 port on the SIT Receiver (point C).
5. Use the SIT Remote to turn on the light mode. Once ON, ensure the LED responds by pressing the color wheel on your RGB LED remote.

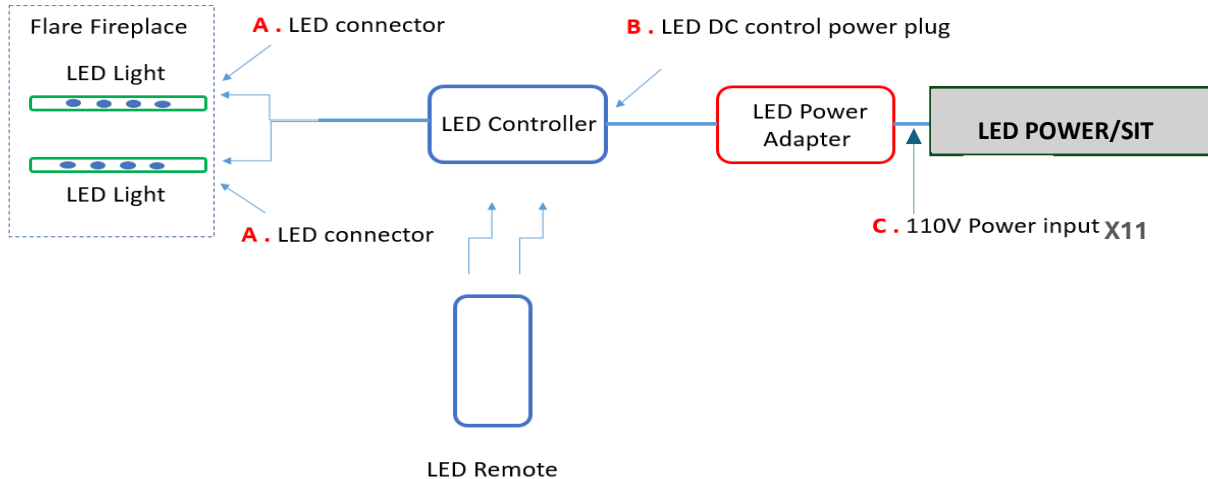

## NOTICE

For independent control of your RGB LED lights, meaning the lights will operate whether the fireplace is on or off, cut off the green molex and ground pin to tie into a standard three-prong plug that can be plugged into its own power outlet. In this scenario only the RGB LED remote can be used to operate the remote.

# FLARE

## FIREPLACES

### OPTIONAL BLOWER KIT – SCREEN UNITS ONLY

The Flare silent blower kit can be added to a safety screened unit to help circulate more heat from the front of the fireplace into the room. The blowers will be powered using a 110V plug. A switch controlling power to the outlet the plug is connected to will be needed in order to turn the fans On and Off, otherwise they will run at all times.

### NOTICE

The blowers will need air intake to successfully operate. **Use the chart below to determine the size of the air intake required.**

Fireplaces sized between 30" – 50"	50 Sq" of open airflow
Fireplaces sized between 60" – 70"	70 Sq" of open airflow
Fireplaces sized between 80" – 100"	100 Sq" of open airflow

### NOTICE

See-Through fireplaces must have air intake balanced on each side to evenly feed fresh air to blower fans. It is recommended to exceed the minimum sizing requirements to help extend the life of your blower fans.



# FLARE FIREPLACES

## VENTING PIPE

This appliance is approved for use with M&G DuraVent venting and ICC. DO NOT mix pipe, fittings or joining methods from different manufacturers.

**DuraVent:** For detailed DuraVent chimney installation information please use the M&G DuraVent direct vent installation manual: <http://www.duravent.com>

**ICC:** For detailed ICC chimney installation information please use the ICC direct vent installation manual: <http://icc-chimney.com/en/exceldirect>

- Where a vent pipe passes through a floor or ceiling, a ceiling firestop must be used to retain insulation and maintain proper clearances. Use roof support brackets where needed.
- Install the first section of vent pipe into the collar on top of the fireplace.
- Connections between each vent system component must be tightly joined and secured. Follow the vent manufacturer's instructions for information on how to seal and secure vent and vent connections.
- Horizontal runs of vent pipe must be supported to prevent any downward sags. Horizontal pipe sections should be supported at least every 4 feet. Wall Straps can be used for this purpose.
- When installing the vent pipe, make sure that the vent pipe is supported by the structural/frame surrounding and not by fireplace.
- Ensure that the insulation is kept clear of the vent pipe using either a wall thimble or an attic insulation shield. Follow the installation instructions supplied with the individual venting components.

## NOTICE

These instructions should be used as a guideline and do not supersede local codes in any way. Install venting according to local codes, these instructions, the current National Fuel Gas Code (ANSI-Z223.1) in the USA or the current standards of CAN/CSA-B149.1 in Canada.

# FLARE FIREPLACES

## VENT PIPE SIZE USED ON EACH FIREPLACE

The vent pipe size used differs based on the size of the fireplace being installed. Also note any fireplace that is being power vented automatically uses the 3x5 CVS pipe, and all Room Definer fireplaces use the 5x8 DVA pipe. Use the following chart to determine what pipe size is used on each fireplace.

Fireplace Size	Vent Pipe Size
Flare 30" Fireplace	4x6
Flare 45" Fireplace	4x6 or *5x8
Flare 50" Fireplace	5x8
Flare 60" Fireplace	5x8
Flare 70" Fireplace	5x8
Flare 80" Fireplace	5x8
Flare 100" Fireplace	5x8

(\*Room Definer Only)

## VENT PIPE - CLEARANCES

A minimum clearance of **3 inches** (76mm) to the top and **1 inch** (51mm) to the sides and bottom of the vent pipe on all horizontal runs to combustibles is required. Horizontal vents must have a 1/4-inch rise for every 1-foot run towards the termination.

A minimum of **1 inch** (25mm) all around the vent pipe on all vertical runs to combustibles is required except for clearances in appliance enclosures.

When penetrating through combustible walls and ceilings, frame a minimum of 10.5 in x 10.5 in opening and ensure that the insulation is kept clear of the vent pipe using either a wall thimble or an attic insulation shield. use the DuraVent framing cutout dimension table based on your selected part.

# FLARE

## FIREPLACES

### DIRECT VENT PIPE CUT-OUT DIMENSIONS

DIRECTVENT PRO FRAMING OR CUTOUT DIMENSIONS		
STOCK NUMBER	COMPONENT DESCRIPTION	SIZE
46DVA-WT	Wall Thimble	10"x 10"
46DVA-WTS	Wall Thimble (Small)	9"x 9"
46DVA-WTU	Wall Thimble Universal	9"x 9"
46DVA-CS	Ceiling Support	10-3/4"x 10-3/4"
46DVA-FS	Fire Stop	9"x 9"
46DVA-WFS	Wall Fire Stop	10"x 10"
46DVA-VSS	Vinyl Siding Standoff	17"x 17"
46DVA-CF	Counter Flashing (Assembled)	13-1/2"x 13-1/2"
46DVA-CFK	Counter Flashing (4pc.Kit)	13-1/2"x 13-1/2"
46DVA-CFKS	Counter Flashing (Kit Small)	10-1/2"x 10-1/2"
46DVA-VSK	Vinyl Siding Standoff (4 Pc.Kit)	13-1/2"x 13-1/2"
46DVA-VSKS	Vinyl Siding Standoff (Kit Small)	10-1/2"x 10-1/2"
46DVA-IS	Insulation Shield	9"x 9"
58DVA-WT	Wall Thimble	10-1/2"x 10-1/2"
58DVA-WTS	Wall Thimble (Small)	9"x 9"
58DVA-WTU	Wall Thimble Universal	9"x 9"
58DVA-CS	Ceiling Support	10-3/4"x 10-3/4"
58DVA-FS	Fire Stop	10-1/2"x 10-1/2"
58DVA-WFS	Wall Fire Stop	10-1/2"x 10-1/2"
58DVA-VSS	Vinyl Siding Standoff	19-1/2"x 19-1/2"
56DVA-VSK	Vinyl Siding Standoff (4 Pc.Kit)	16"x 16"
58DVA-CF	Counter Flashing (Assembled)	16"x 16"
58DVA-CFK	Counter Flashing (4pc.Kit)	16"x 16"
58DVA-IS	Insulation Shield	11"x 11"

# FLARE

## FIREPLACES

### VERTICAL TERMINATIONS

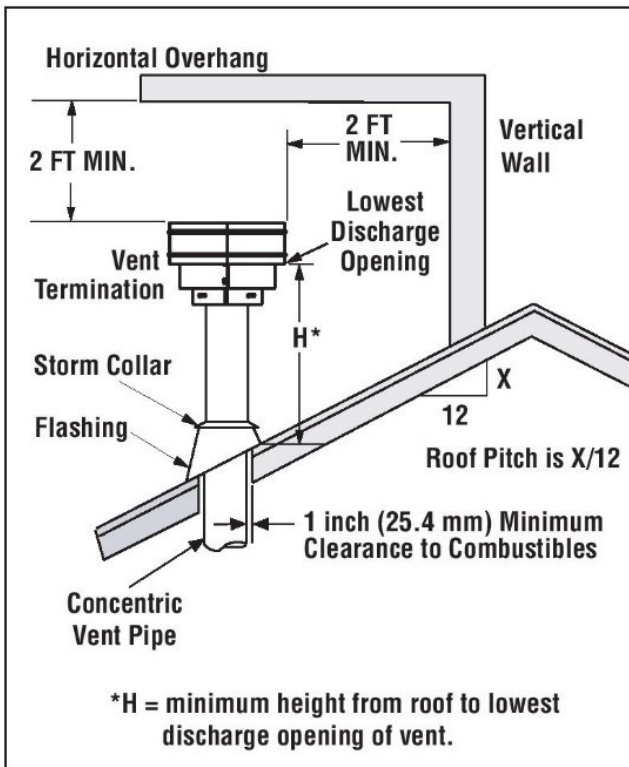
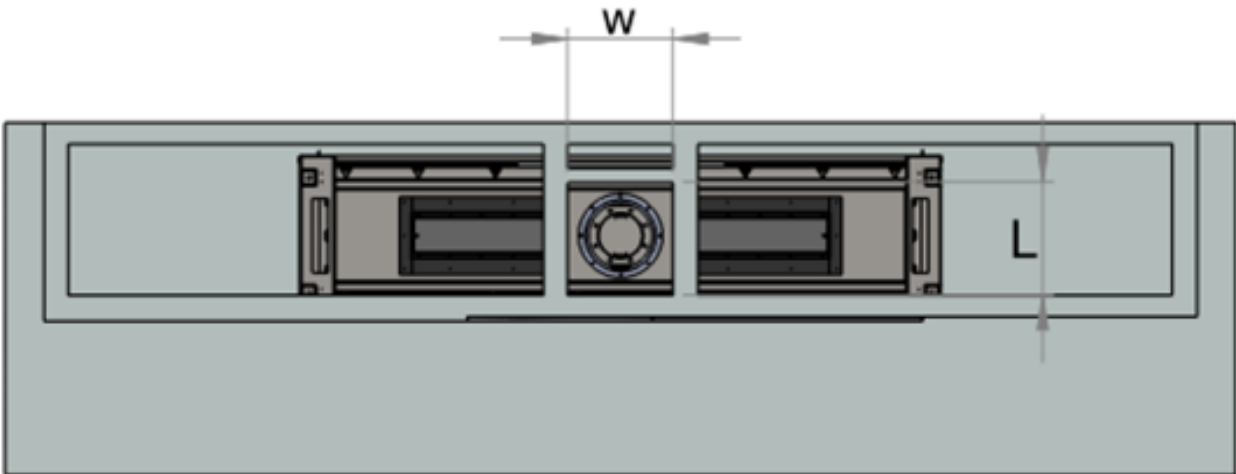

**Termination Heights for Vents Above Flat or Sloped Roofs (Ref. NFPA 54 / ANSI Z223.1)**

Roof Pitch	*Feet	*Meters
Flat to 6/12	1.0	0.3
6/12 to 7/12	1.25	0.38
7/12 to 8/12	1.5	0.46
8/12 to 9/12	2.0	0.61
9/12 to 10/12	2.5	0.76
10/12 to 11/12	3.25	0.99
11/12 to 12/12	4.0	1.22
12/12 to 14/12	5.0	1.52
14/12 to 16/12	6.0	1.83
16/12 to 18/12	7.0	2.13
18/12 to 20/12	7.5	2.29
20/12 to 21/12	8.0	2.44

\* Minimum 24" horizontal clearance to any surface, such as exterior walls, for vertical terminations.

# FLARE

## FIREPLACES

### MULTIPLE VERTICAL TERMINATIONS

A	B
6" Minimum up to 20"	18" minimum
20" and over	0" minimum

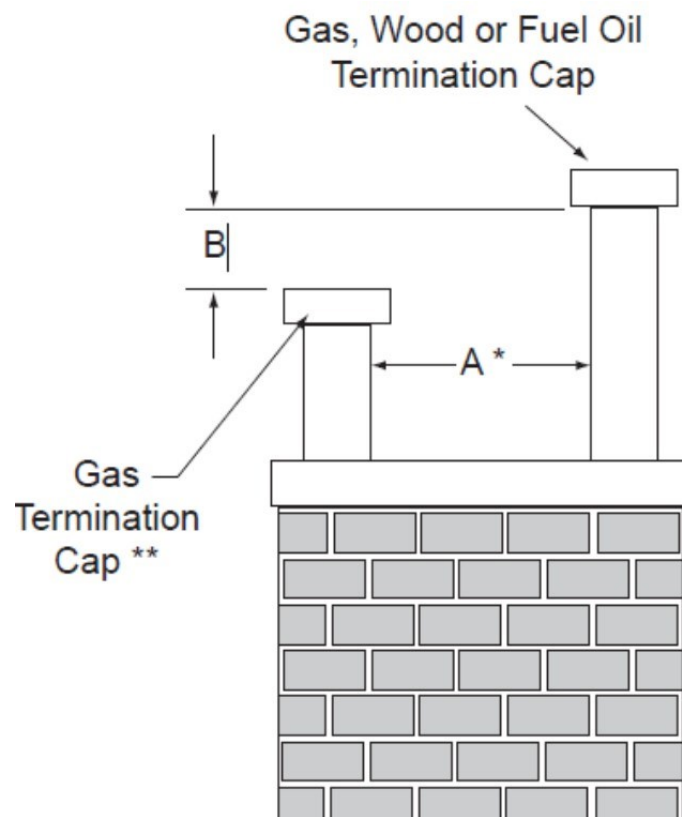

# FLARE

## FIREPLACES

---

### HORIZONTAL TERMINATIONS

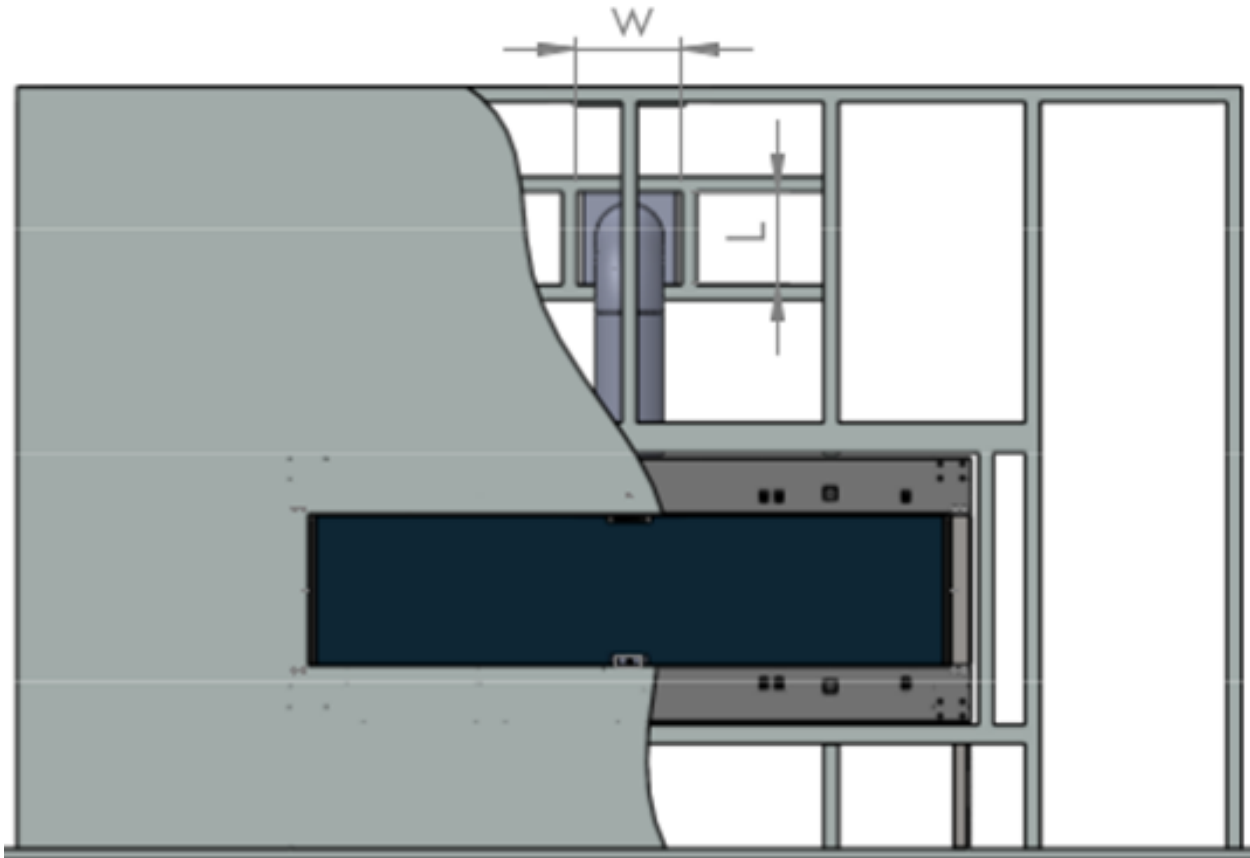

---

### MULTIPLE HORIZONTAL TERMINATIONS

A minimum distance of 18" should be kept between multiple horizontal terminations

# FLARE

## FIREPLACES

### VENT TERMINATION CLEARANCES

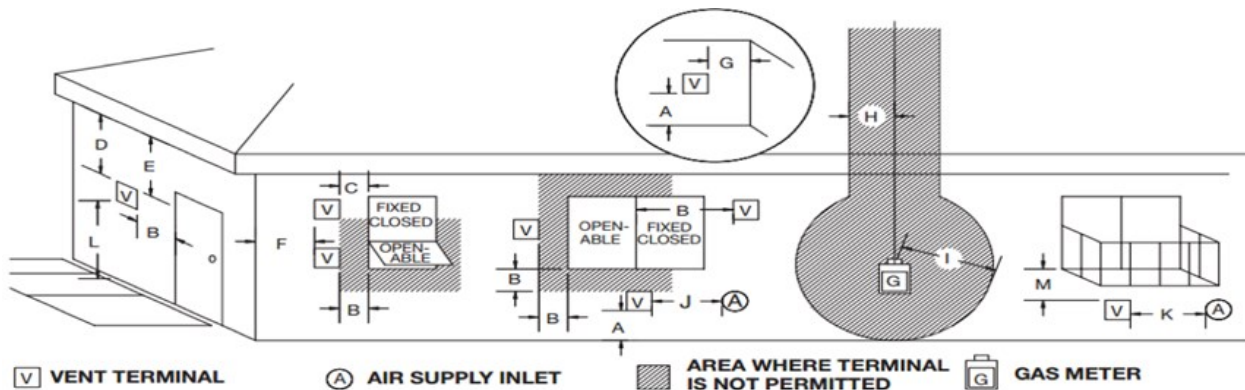

A	<sup>^</sup> 12" Minimum	Clearance above grade veranda, porch, deck, or balcony.
B	**12" Minimum	Clearance to operational window or door.
C	12" Minimum	Clearance to inoperable window or door.
D	24" for Flares sized 80"-100"	Vertical clearance to ventilated soffit located above the terminal within a horizontal distance of 2' from edge of terminal. Vinyl surfaces require 24" minimum.
	18" for Flares sized 30"-70"	
E	24" for Flares sized 80"-100"	Clearance to unventilated soffit. Vinyl surfaces require 24" minimum.
	18" for Flares sized 30"-70"	
F	6" Minimum	Clearance to outside corner.
G	6" Minimum	Clearance to inside corner.
H	3' Minimum	*Not to be installed above meter/regulator assembly within 3' horizontally from the centerline of the regulator.
I	3' Minimum	Clearance to service regulator vent outlet
J	*12" Minimum	Clearance to non-mechanical air supply inlet to building or the combustion air inlet to any other appliance.
K	*6' Minimum	Clearance to a mechanical air supply inlet.
L	***7' Minimum	Clearance above paved sidewalk or a paved driveway located on public property.
M	***20" Minimum	Clearance under veranda, porch, deck, or balcony.

- <sup>^</sup> Vent shall not terminate directly above a sidewalk or paved driveway, located between two single family dwellings, serving both dwellings.
- \*\* Only permitted if veranda, porch, deck, or balcony is fully open on a minimum of 2 sides beneath the door.
- \* Clearance in accordance with local installation codes and the requirements of the gas supplier.
- \* As specified in CGA B149 Installation Codes, note local Codes or Regulation may require different clearances.
- \* For U.S.A. Installations follow the current National Fuel Gas Code, ANSI Z223.1
- \*\*\* Horizontal vent termination minimum clearance to adjacent structure or fence is 48".
- \*\*\*\* Minimum 24" horizontal clearance to any surface (such as an exterior wall) for vertical terminations.

# FLARE FIREPLACES

## VENT RESTRICTOR SETUP

The Flare Fireplace direct vent system is equipped with a vent restrictor. Use Chimney Path Installation and Planning to determine the right vent restrictor setup for your installation. The unit leaves the factory with the restrictor open. Once the vent run is determined the restrictor can be adjusted using a 10mm wrench. Document the restrictor setting so it can be used in conjunction with your vent run layout to determine a successful natural draft.

## NOTICE

Vent restrictor setup and adjustments should only be done by a certified installer.



## SIGNS A VENT RESTRICTOR ADJUSTMENT IS NEEDED

The vent restrictor should be opened if the flame has the following characteristics:

- Excessively tall flame while lifting off the burner.
- Flame lacks movement.

The vent restrictor should be closed if the flame has the following characteristics:

- Low flame height.
- Excessive flame movement.



# FLARE

## FIREPLACES

### ADJUSTING AIR SHUTTER

The correct fuel-air mixture in your Flare Fireplace produces yellow flame tips, with blue base and offers minimal soot buildup. The Fuel-air mixture is set by the factory, but may need adjustment by fireplace installer, depending on site conditions. **In all cases, it is recommended to verify inlet pressure to match recommended values, in addition to setting the air shutter on the burner.**

#### 1. Identifying and locating the air shutter on your Flare Fireplace.

**EX 1: ON THE BURNER**



**EX 2: UNDER YOUR FIREPLACE**



- **Example 1:** If there is no access to the underside of the fireplace, the adjustment can be made from inside the fireplace, on the burner. Each burner (**up to three burners, on units 60" and above**) has a + and – sign located on it. In between that + and – sign is a Philips head screw or bolt that can be turned to either open or close the air shutter. **See Ex. 1 above for visual.**
- **Example 2:** The second option allows you to adjust your Flare Fireplaces air shutter by accessing it from directly underneath the fireplace. **See Ex. 2 above for visual**

#### **Adjust the Air shutter if the Air to Fuel mixture is not correct:**

- If the flame is yellow or orange and produces soot (low air leading to a rich flame) - Introduce more air by turning clockwise.
- The flame is very blue (too much air) - Reduce the air by turning counterclockwise.

#### **Common reason air shutter adjustment may be needed:**

- LP conversion has been done.
- High above sea level installation. High elevation with low oxygen in the air.
- Soot buildup on the glass or termination cap

# FLARE FIREPLACES

## CHIMNEY PATH PLANNING AND INSTALLATION

To calculate the vent runs, use the following tables and instructions. Please note that power vent runs are model specific. Use the tables below to calculate the restrictor setting. These fireplaces are designed and tested to function with natural venting in equal pressure environments. Natural venting allows hot air and CO<sub>2</sub> to rise and exhaust out through the vent naturally while simultaneously creating a slight draft of oxygen to allow the flame to burn clean and efficiently. Please know that if your installation environment presents negative or positive pressure, caused by strong HVAC systems or kitchen hoods, a power vent system may be needed to counter this unique environment.

- Diagonal runs have both vertical and horizontal vent aspects when calculating the effects. Use the rise for the vertical aspect and the run for the horizontal aspect.
- Various combinations of vent runs may be used. Refer to the tables below based on Fireplace size.
- The numbers in the table represent the restrictor setting based on the vent path.
- Symbol “x” in the table means the path is not allowed.
- Setting the restrictor to 1 means there is no restriction.
- Numbers in the table represent the restrictor setting to be set.
- Document the restrictor setting configuration prior to leaving the installation site.
- The tables apply to both NG (Natural Gas) and Propane.
- Minimum 3 ft vertical run (A) required before any bend or turn on fireplaces sized 30” – 70”
- Minimum 6 ft vertical run (A) required before any bend or turn on fireplaces sized 80” – 100”
- A maximum of **four** 90° vent elbows are allowed in the vent run. Any configuration with more than 4 elbows requires vent review and approval from Flare Fireplaces.
- Two 45° elbows may be used in place of one 90° elbow.
- The tables represent the manufacturer’s guideline based on testing and design. Additional external factors may affect the restrictor choice needed. If flames appear to be not typical, please contact Flare Fireplaces for restrictor size recommendations.
- Use the empty table in the page below to document and calculate the installation vent path.
- Any venting pathway that does not appear in the tables below require approval from Flare Fireplaces.
- For optimum performance and flame appearance, keep the vent length to a minimum and limit the number of elbows.

# FLARE

## FIREPLACES

### FLARE 30R/30H/PASSAGE

Suitable for all 30R/30H/30EH

Length Calculation Guide
<b>Y-Effective Axis Parameters</b>
A - 1st Flue Length (3 ft. Minimum Rise)
B - Vertical Flue Length
C - Roof Terminal = 1.5 ft.
H - Small Elbow (45°) = 1 ft.
<b>X-Effective Axis Parameters</b>
D - Horizontal Flue Length
E - Elbow (90°) = 3 ft.
F - Elbow (Lying 90°) = 6 ft.
G - Wall Terminal = 3 ft.

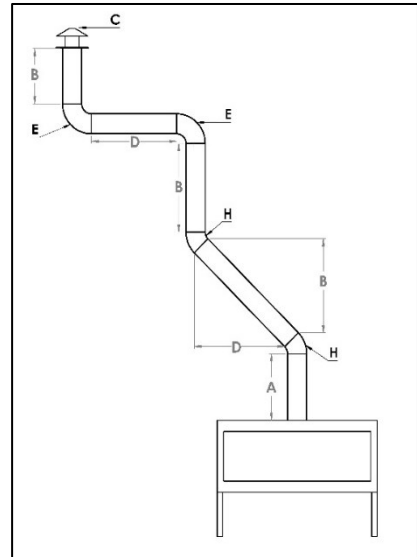
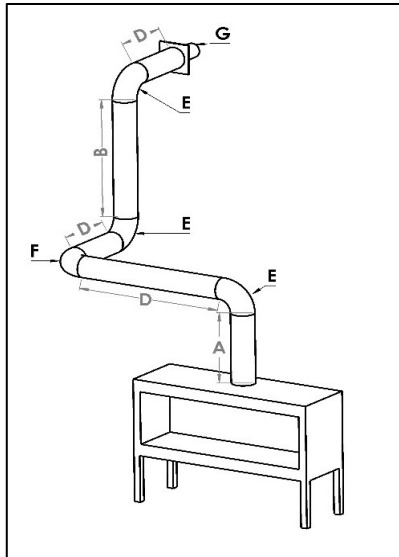

**Vent Restrictor Setting:** Determined by calculation of the unique run. Set to 1, 2, 3, 4, 5, 6 using chart below. An X requires the run to be power vented.

Y- Effective Vertical Length	X- Effective Horizontal Length													
	FEET	0	3	6'	10'	13'	17'	20'	23'	26'	30'	33'	36'	39'
3'	3	2	1	1	1	1	1	1	1	1	X	X	X	X
6'	3	2	2	1	1	1	1	1	1	1	1	1	X	X
10'	3	2	2	1	1	1	1	1	1	1	1	1	1	1
13'	2	2	1	1	1	1	1	1	1	1	1	1	1	1
16'	2	1	1	1	1	1	1	1	1	1	1	1	1	1
19'	2	1	1	1	1	1	1	1	1	1	1	1	1	1
23'	2	1	1	1	1	1	1	1	1	1	1	1	X	X
26'	1	1	1	1	1	1	1	1	1	1	1	1	X	X
30'	1	1	1	1	1	1	1	1	1	1	X	X	X	X
33'	1	1	1	1	1	1	1	1	1	1	X	X	X	X
36'	1	1	1	1	1	1	1	X	X	X	X	X	X	X
39'	1	1	1	1	1	1	1	X	X	X	X	X	X	X
43'	1	1	1	1	1	1	1	X	X	X	X	X	X	X
46'	1	1	1	1	1	1	1	X	X	X	X	X	X	X
50'	1	1	1	1	1	1	1	X	X	X	X	X	X	X

# FLARE FIREPLACES

## FLARE 45R/45H/45EH

Suitable for all 45R/45H/45EH Fireplaces

Length Calculation Guide
<b>Y-Effective Axis Parameters</b>
A - 1st Flue Length (3 ft. Minimum Rise)
B - Vertical Flue Length
C - Roof Terminal = 1.5 ft.
H - Small Elbow (45°) = 1 ft.
<b>X-Effective Axis Parameters</b>
D - Horizontal Flue Length
E - Elbow (90°) = 3 ft.
F - Elbow (Lying 90°) = 6 ft.
G - Wall Terminal = 3 ft.

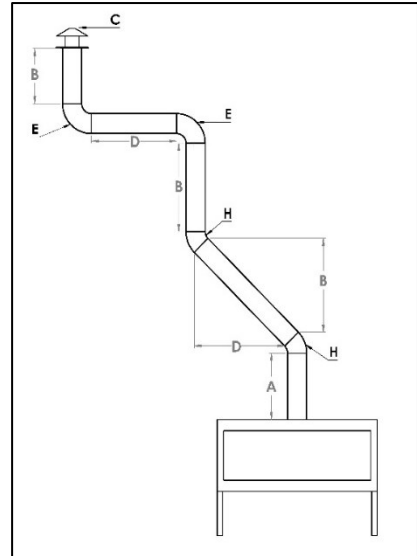
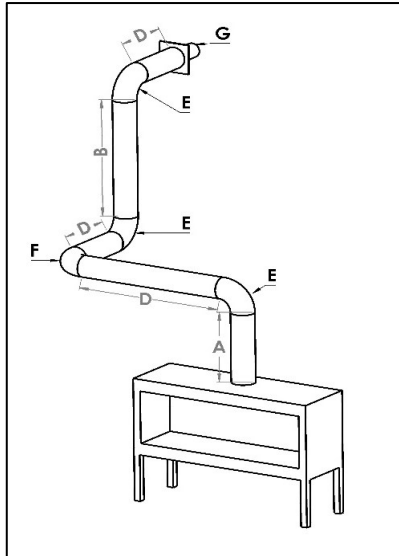

**Vent Restrictor Setting:** Determined by calculation of the unique run. Set to 1, 2, 3, 4, 5, 6 using chart below. An X requires the run to be power vented.

Y-Effective Vertical Length	Flare 45/45H/45EH	X- Effective Horizontal Length												
	FEET	0	3	6'	10'	13'	17'	20'	23'	26'	30'	33'	36'	39'
3'	1	1	1	1	1	1	1	1	1	X	X	X	X	X
6'	3	2	2	1	1	1	1	1	1	X	X	X	X	X
10'	3	2	2	1	1	1	1	1	1	1	1	X	X	X
13'	2	2	2	1	1	1	1	1	1	1	1	1	1	X
16'	2	1	1	1	1	1	1	1	1	1	1	1	1	X
19'	2	1	1	1	1	1	1	1	1	1	1	1	X	X
23'	1	1	1	1	1	1	1	1	1	1	1	X	X	X
26'	1	1	1	1	1	1	1	1	1	1	X	X	X	X
30'	1	1	1	1	1	1	1	1	1	X	X	X	X	X
33'	1	1	1	1	1	1	1	1	1	X	X	X	X	X
36'	1	1	1	1	1	1	1	1	1	X	X	X	X	X
39'	1	1	1	1	1	1	1	1	X	X	X	X	X	X
43'	1	1	1	1	1	1	1	1	X	X	X	X	X	X
46'	1	1	1	1	1	1	1	X	X	X	X	X	X	X
50'	1	1	1	1	1	1	1	X	X	X	X	X	X	X

# FLARE FIREPLACES

## FLARE 50R/50H/50EH

Suitable for all 50R/50H/50EH Fireplaces

Length Calculation Guide
<b>Y-Effective Axis Parameters</b>
A - 1st Flue Length (3 ft. Minimum Rise)
B - Vertical Flue Length
C - Roof Terminal = 1.5 ft.
H - Small Elbow (45°) = 1 ft.
<b>X-Effective Axis Parameters</b>
D - Horizontal Flue Length
E - Elbow (90°) = 3 ft.
F - Elbow (Lying 90°) = 6 ft.
G - Wall Terminal = 3 ft.

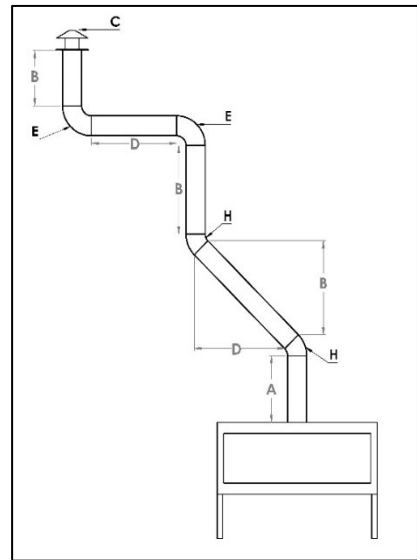
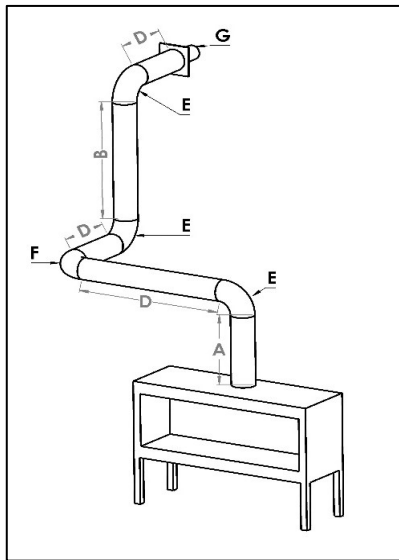

**Vent Restrictor Setting:** Determined by calculation of the unique run. Set to 1, 2, 3, 4, 5, 6 using chart below. An X requires the run to be power vented.

Y-Effective Vertical Length	Flare 50/50H	X- Effective Horizontal Length												
	FEET	0	3	6'	10'	13'	17'	20'	23'	26'	30'	33'	36'	39'
3'	2	2	2	2	1	1	1	1	1	1	1	1	X	X
6'	3	3	2	2	2	2	1	1	1	1	1	1	1	1
10'	3	3	2	2	2	2	1	1	1	1	1	1	1	1
13'	3	3	2	2	2	1	1	1	1	1	1	1	1	1
16'	3	3	2	2	2	1	1	1	1	1	1	1	1	1
19'	2	2	2	2	2	1	1	1	1	1	1	1	1	1
23'	2	2	2	2	1	1	1	1	1	1	1	1	1	1
26'	2	2	2	2	1	1	1	1	1	1	1	1	1	1
30'	2	2	2	1	1	1	1	1	1	1	1	1	1	1
33'	1	1	1	1	1	1	1	1	1	1	1	1	1	1
36'	1	1	1	1	1	1	1	1	1	1	X	X	X	X
39'	1	1	1	1	1	1	1	1	1	1	X	X	X	X
43'	1	1	1	1	1	1	1	1	1	1	X	X	X	X
46'	1	1	1	1	1	1	1	1	1	X	X	X	X	X
50'	1	1	1	1	1	1	1	1	1	X	X	X	X	X

# FLARE FIREPLACES

FLARE 60R/60H/60EH

Suitable for all 60R/60H/60EH Fireplaces

Length Calculation Guide	
Y-Effective Axis Parameters	
A	1st Flue Length (3 ft. Minimum Rise)
B	Vertical Flue Length
C	Roof Terminal = 1.5 ft.
H	Small Elbow (45°) = 1 ft.
X-Effective Axis Parameters	
D	Horizontal Flue Length
E	Elbow (90°) = 3 ft.
F	Elbow (Lying 90°) = 6 ft.
G	Wall Terminal = 3 ft.

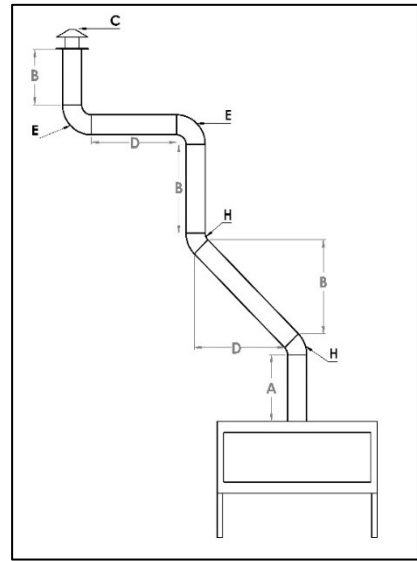
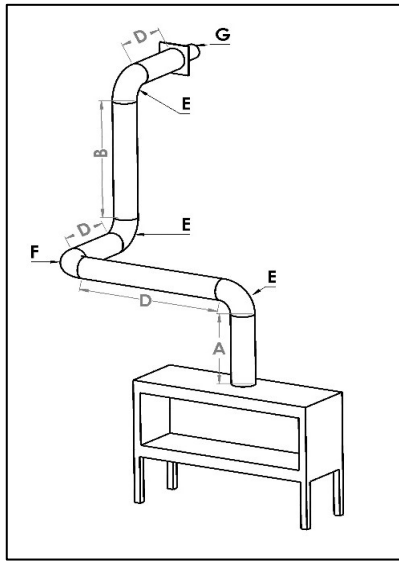

**Vent Restrictor Setting:** Determined by calculation of the unique run. Set to 1, 2, 3, 4, 5, 6 using chart below. An X requires the run to be power vented.

Y-Effective Vertical Length	Flare 60/60H	X- Effective Horizontal Length												
	FEET	0	3	6'	10'	13'	17'	20'	23'	26'	30'	33'	36'	39'
3'	2	2	1	1	1	1	1	1	1	1	1	X	X	X
6'	3	3	2	1	1	1	1	1	1	1	1	1	1	X
10'	2	2	2	1	1	1	1	1	1	1	1	1	1	1
13'	2	2	2	2	1	1	1	1	1	1	1	1	1	1
16'	2	2	2	1	1	1	1	1	1	1	1	1	1	1
19'	2	2	1	1	1	1	1	1	1	1	1	1	1	1
23'	2	2	1	1	1	1	1	1	1	1	1	1	1	1
26'	1	1	1	1	1	1	1	1	1	1	1	1	1	1
30'	1	1	1	1	1	1	1	1	1	1	1	1	1	1
33'	1	1	1	1	1	1	1	1	1	1	1	X	X	X
36'	1	1	1	1	1	1	1	1	1	1	1	X	X	X
39'	1	1	1	1	1	1	1	1	1	1	1	X	X	X
43'	1	1	1	1	1	1	1	1	1	X	X	X	X	X
46'	1	1	1	1	1	1	1	1	1	X	X	X	X	X
50'	1	1	1	1	1	1	1	1	1	X	X	X	X	X

# FLARE FIREPLACES

## FLARE 70R/70H/70EH

Suitable for all Flare 70R/70H/70EH Fireplaces

Length Calculation Guide	
<b>Y-Effective Axis Parameters</b>	
A	1st Flue Length (3 ft. Minimum Rise)
B	Vertical Flue Length
C	Roof Terminal = 1.5 ft.
H	Small Elbow (45°) = 1 ft.
<b>X-Effective Axis Parameters</b>	
D	Horizontal Flue Length
E	Elbow (90°) = 3 ft.
F	Elbow (Lying 90°) = 6 ft.
G	Wall Terminal = 3 ft.

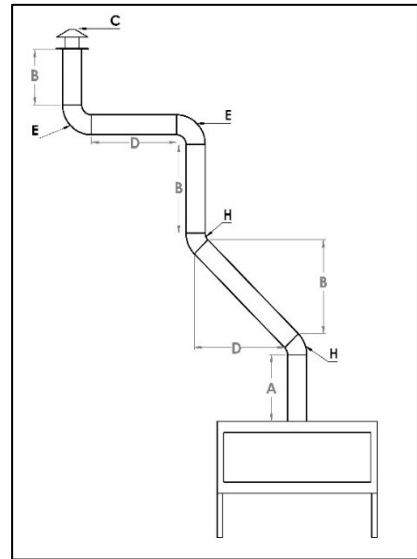
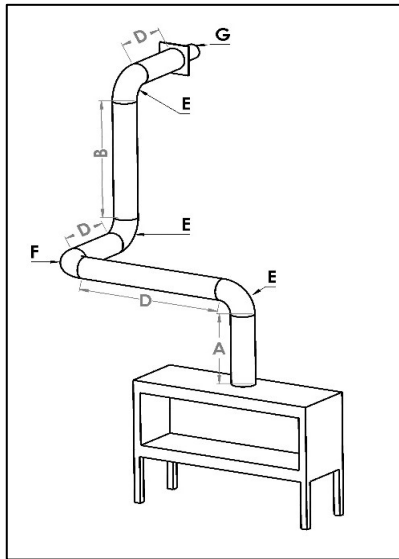

**Vent Restrictor Setting:** Determined by calculation of the unique run. Set to 1, 2, 3, 4, 5, 6 using chart below. An X requires the run to be power vented.

Y-Effective Vertical Length	X- Effective Horizontal Length													
	FEET	0	3'	6'	10'	13'	17'	20'	23'	26'	30'	33'	36'	39'
3'	1	1	1	1	1	1	1	1	1	1	X	X	X	X
6'	2	2	1	1	1	1	1	1	1	1	1	X	X	X
10'	3	2	1	1	1	1	1	1	1	1	1	1	1	X
13'	3	2	1	1	1	1	1	1	1	1	1	1	1	X
16'	2	2	1	1	1	1	1	1	1	1	1	1	1	1
19'	2	2	1	1	1	1	1	1	1	1	1	1	1	X
23'	2	1	1	1	1	1	1	1	1	1	1	1	X	X
26'	1	1	1	1	1	1	1	1	1	1	1	X	X	X
30'	1	1	1	1	1	1	1	1	1	1	1	X	X	X
33'	1	1	1	1	1	1	1	1	1	X	X	X	X	X
36'	1	1	1	1	1	1	1	1	1	X	X	X	X	X
39'	1	1	1	1	1	1	1	1	X	X	X	X	X	X
43'	1	1	1	1	1	1	1	1	X	X	X	X	X	X
46'	1	1	1	1	1	1	1	1	X	X	X	X	X	X
50'	1	1	1	1	1	1	1	1	X	X	X	X	X	X



# FLARE FIREPLACES

## FLARE 80R/80H/80EH

Suitable for all Flare 80R/80H/80EH Fireplaces

Length Calculation Guide
Y-Effective Axis Parameters
A - 1st Flue Length (6ft. Minimum Rise)
B - Vertical Flue Length
C - Roof Terminal = 1.5 ft.
H - Small Elbow (45°) = 1 ft.
X-Effective Axis Parameters
D - Horizontal Flue Length
E - Elbow (90°) = 3 ft.
F - Elbow (Lying 90°) = 6 ft.
G - Wall Terminal = 3 ft.

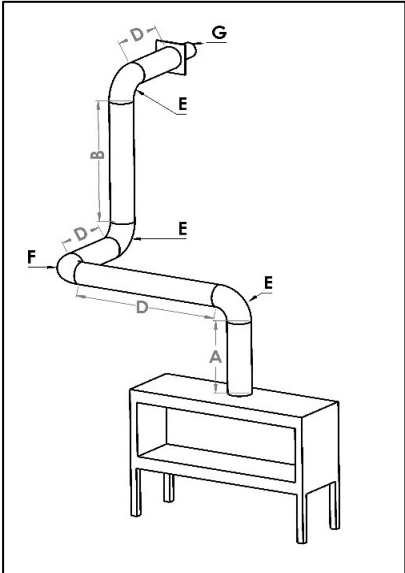
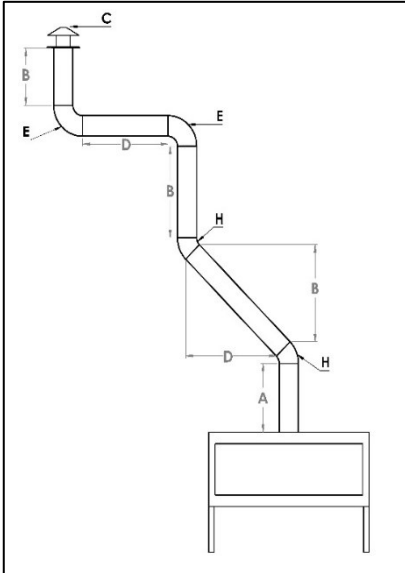
**Vent Restrictor Setting:** Determined by calculation of the unique run. Set to 1, 2, 3, 4, 5, 6 using chart below. An X requires the run to be power vented.

Y- Effective Vertical Length	Flare 80/80H/80EH	X- Effective Horizontal Length												
	FEET	0	3	6'	10'	13'	17'	20'	23'	26'	30'	33'	36'	39'
3'		X	X	X	X	X	X	X	X	X	X	X	X	X
6'		2	1	1	1	1	1	X	X	X	X	X	X	X
10'		2	2	1	1	1	1	1	1	X	X	X	X	X
13'		2	2	1	1	1	1	1	1	1	X	X	X	X
16'		2	1	1	1	1	1	1	1	1	X	X	X	X
19'		2	1	1	1	1	1	1	1	1	X	X	X	X
23'		1	1	1	1	1	1	1	1	1	1	X	X	X
26'		1	1	1	1	1	1	1	1	1	1	1	X	X
30'		1	1	1	1	1	1	1	1	1	1	1	X	X
33'		1	1	1	1	1	1	1	1	1	1	X	X	X
36'		1	1	1	1	1	1	1	1	X	X	X	X	X
39'		1	1	1	1	1	1	1	1	X	X	X	X	X
43'		1	1	1	1	1	1	1	X	X	X	X	X	X
46'		1	1	1	1	1	1	X	X	X	X	X	X	X
50'		1	1	1	1	1	1	X	X	X	X	X	X	X

# FLARE

## FIREPLACES

FLARE 100/100H/100EH

Suitable for all Flare 100/100H/100EH Fireplaces

Length Calculation Guide
<b>Y-Effective Axis Parameters</b>
A - 1st Flue Length (6ft. Minimum Rise)
B - Vertical Flue Length
C - Roof Terminal = 1.5 ft.
H - Small Elbow (45°) = 1 ft.
<b>X-Effective Axis Parameters</b>
D - Horizontal Flue Length
E - Elbow (90°) = 3 ft.
F - Elbow (Lying 90°) = 6 ft.
G - Wall Terminal = 3 ft.

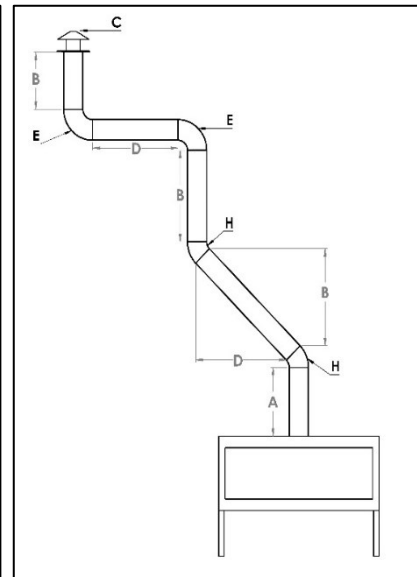
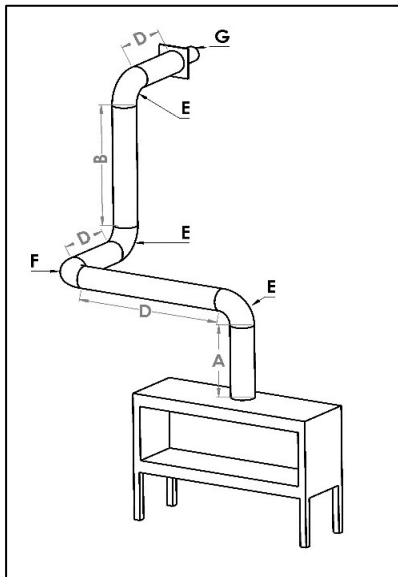

**Vent Restrictor Setting:** Determined by calculation of the unique run. Set to 1, 2, 3, 4, 5, 6 using chart below. An X requires the run to be power vented.

Y-Effective Vertical Length	X- Effective Horizontal Length													
	FEET	0	3	6'	10'	13'	17'	20'	23'	26'	30'	33'	36'	39'
3'	X	X	X	X	X	X	X	X	X	X	X	X	X	X
6'	2	1	1	1	1	1	X	X	X	X	X	X	X	X
10'	2	2	1	1	1	1	1	1	X	X	X	X	X	X
13'	2	2	1	1	1	1	1	1	1	X	X	X	X	X
16'	2	1	1	1	1	1	1	1	1	X	X	X	X	X
19'	2	1	1	1	1	1	1	1	1	X	X	X	X	X
23'	1	1	1	1	1	1	1	1	1	1	X	X	X	X
26'	1	1	1	1	1	1	1	1	1	1	1	X	X	X
30'	1	1	1	1	1	1	1	1	1	1	X	X	X	X
33'	1	1	1	1	1	1	1	1	1	X	X	X	X	X
36'	1	1	1	1	1	1	1	1	X	X	X	X	X	X
39'	1	1	1	1	1	1	1	1	X	X	X	X	X	X
43'	1	1	1	1	1	1	1	X	X	X	X	X	X	X
46'	1	1	1	1	1	1	X	X	X	X	X	X	X	X
50'	1	1	1	1	1	1	X	X	X	X	X	X	X	X

# FLARE FIREPLACES

## POWER VENTING

For unsupported vent routes (based on the gravity vent tables above) a power venting solution is required. The power venting solutions allow Flare Fireplaces to operate in vent conditions that would not be possible without the motor unit. See the [Flare Power Vent Installation Manual](#) for more specific instructions.

The system is designed and tested with DuraVent 3x5 gasket direct vent pipes. It is critical for the safety and operation of the system to use the DuraVent 3x5 gasket system.

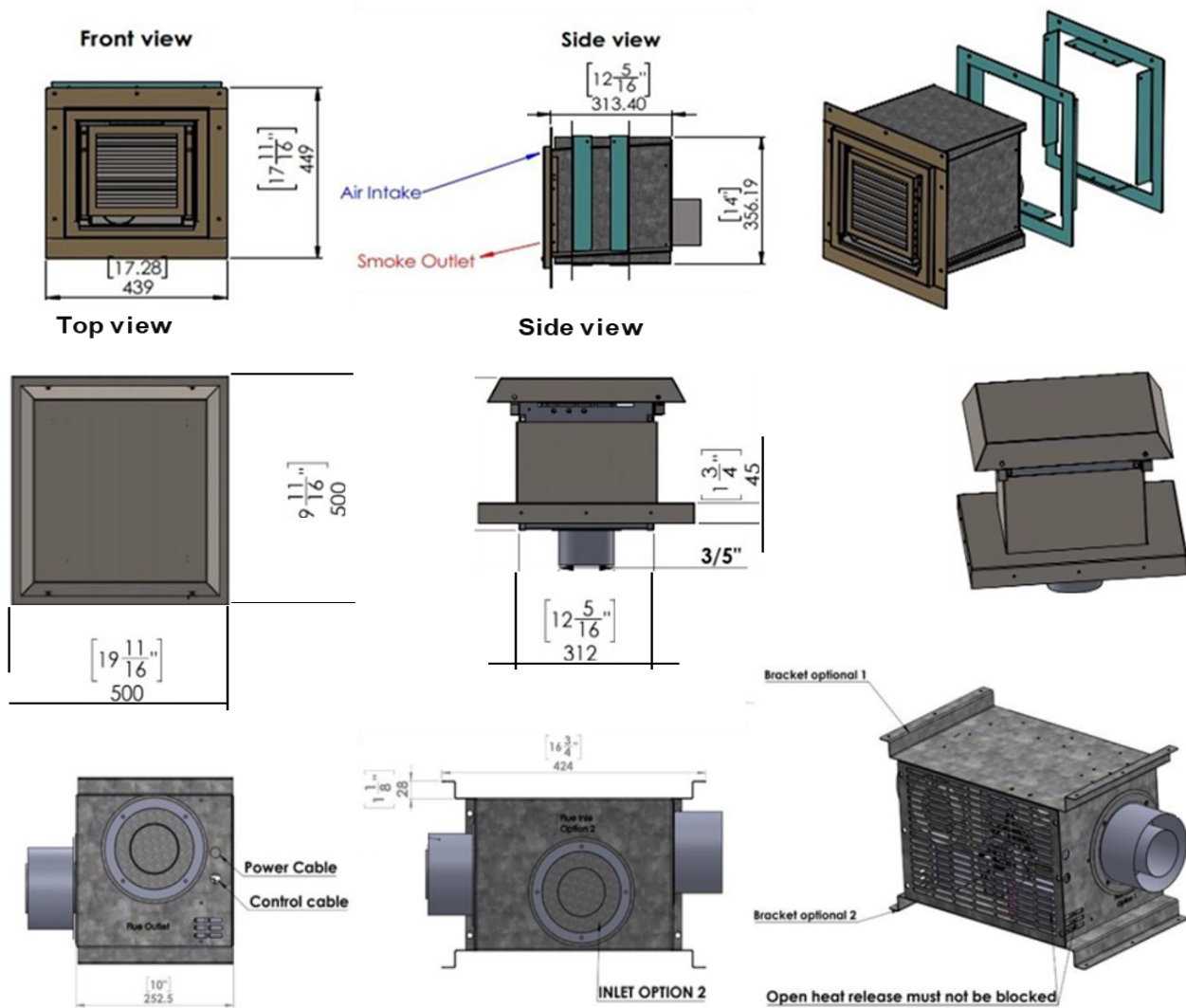

# FLARE FIREPLACES

When using the power vent system, direction of flow through the vents can be up, down, horizontal or diagonal since the system is sealed and vacuumed. The vent restrictor level should be set based on length in feet, number of elbows and the vent termination.

## NOTICE

A minimum length of **12ft venting** is required between the Fireplace and the SK, Flare Fireplaces sizes **30"-70"**. A minimum length of **15ft**, Flare sizes **80"-100"**, is required between the fireplace and the SK. For more information, please reference the [Power Vent Installation Manual](#).

**Clearance** - Clearances between the vent pipe and combustible materials must be maintained at 3" inches top and 1" for side and below. Maintain the same clearance from the power vent box to any combustible materials.

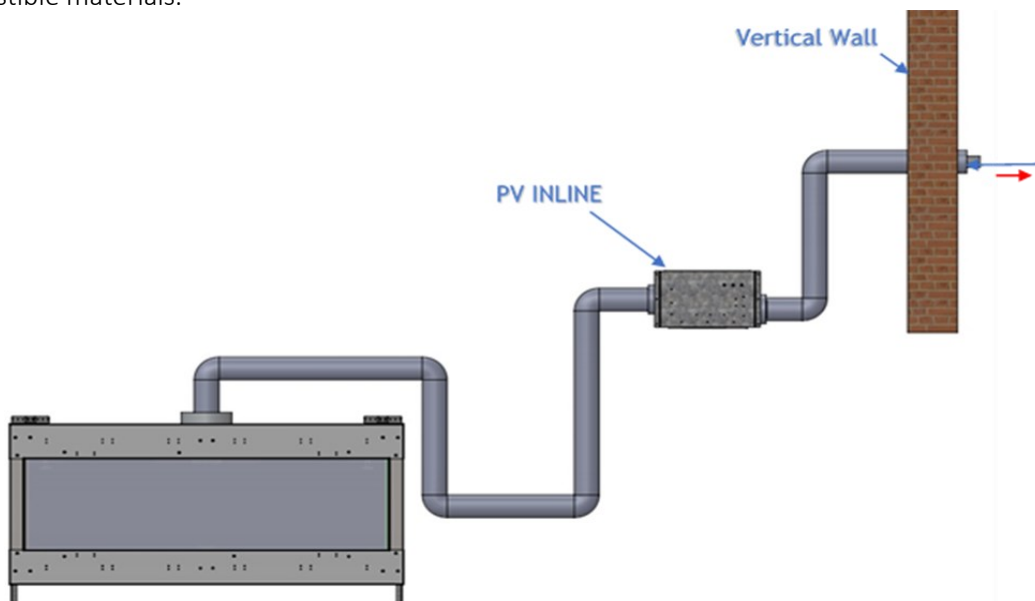

## WARNING

A power vented unit must be installed by a qualified installer in accordance with these instructions. CAUTION! Failure to install, operate, and maintain the power venting system in accordance with manufacturer's instructions will result in conditions which may produce bodily injury and/or property damage.

# FLARE FIREPLACES

## ELECTRICAL CONNECTION TO THE POWER VENT SYSTEM

- The PV system will be getting 115V from the Flare Fireplace board.
- The PV system is connected to the Fireplace control system with a **high voltage 4 wire cable** - labeled below as connection “PV Power 115V”.
- Cable to be used is 16 AWG-4 copper wire. Cable is not included with the PV kit and can be sourced separately.
- Connect 4 wire high voltage cable from the Power Vent to matching colors - white to white, black to black & green to green and red to red on the PV system.
- The Flare Fireplaces Fan board is a must for operating a Flare Fireplace with a PV system.

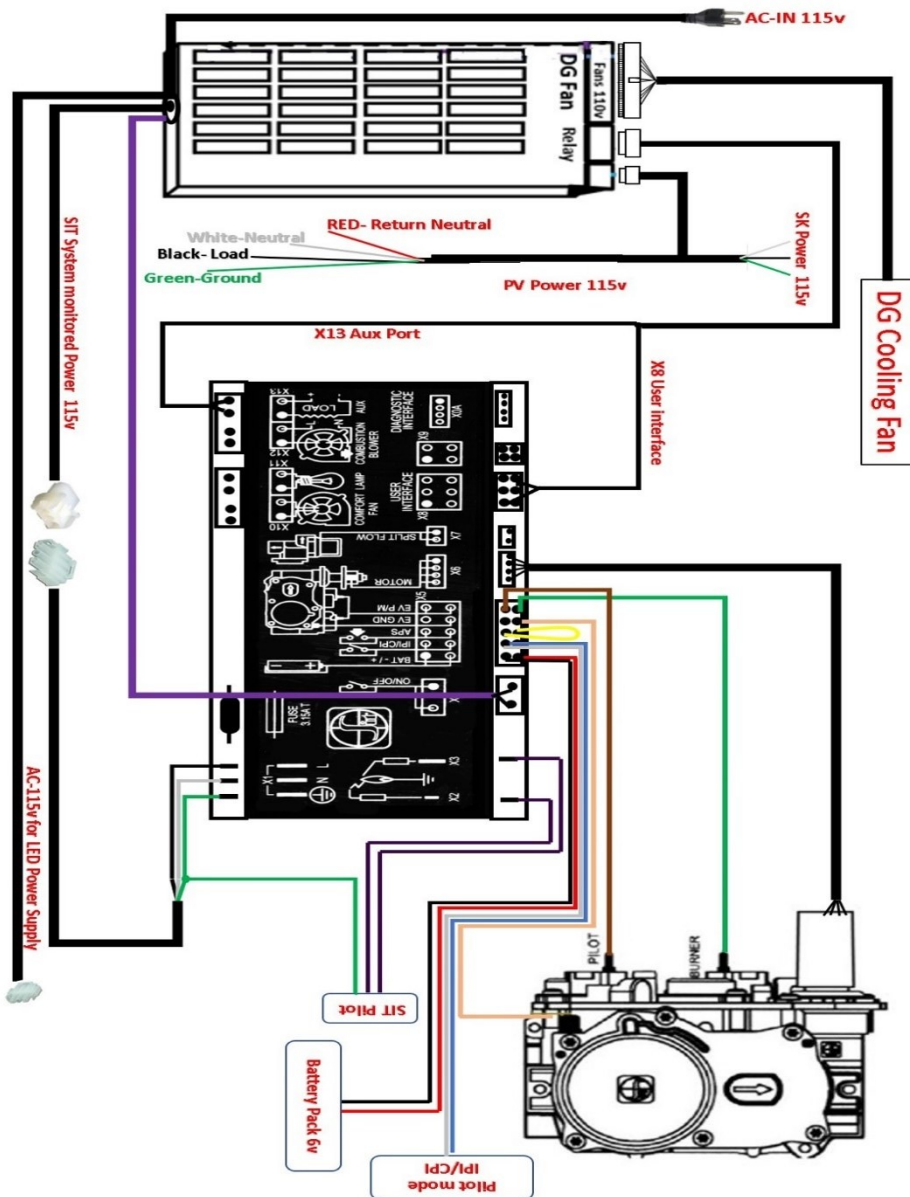

# FLARE FIREPLACES

## POWER VENT BOARD ELECTRICAL WIRING DRAWING

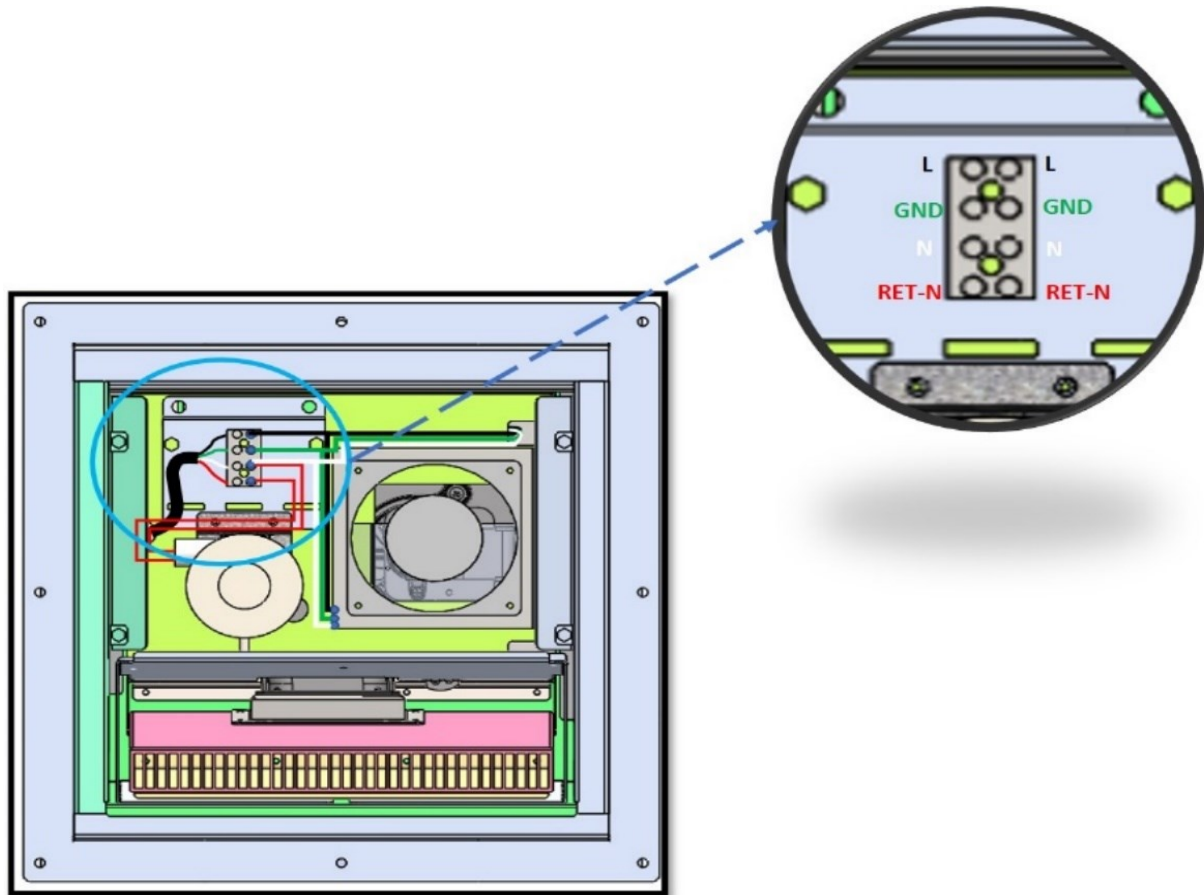

# FLARE

## FIREPLACES

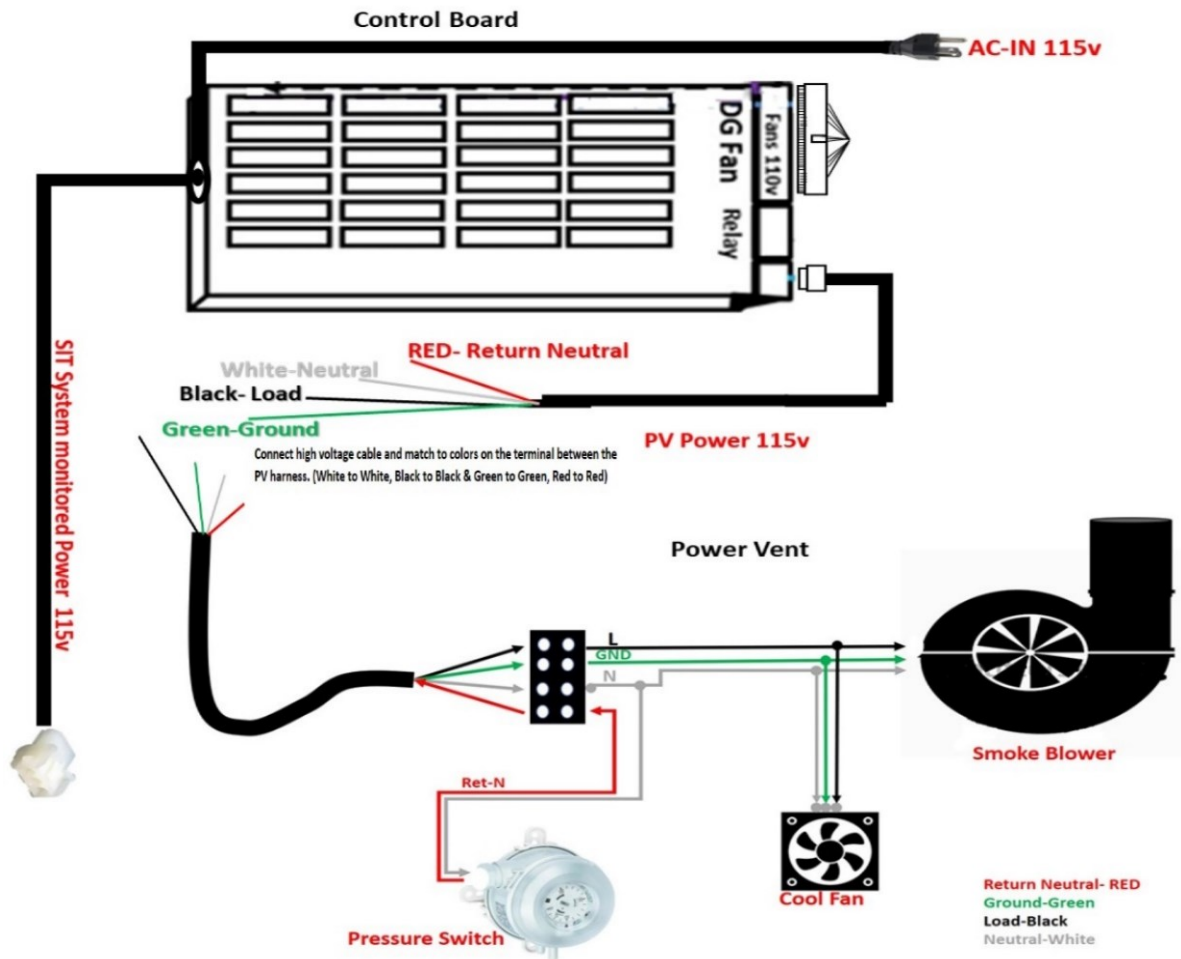

# FLARE

## FIREPLACES

### GAS REQUIREMENTS

#### WARNING! RISK OF FIRE OR EXPLOSION!

All gas handling and installation should be performed by qualified service technician or installer.

Gas build-up during line purge could ignite. Ensure adequate ventilation. Make sure there are no ignition sources/sparks or open flames.

Do not change the gas valve setting! The fireplace gas valve has been preset at the factory.

Installing an external manual gas valve before connection to the fireplace is a must.

Make sure to check for gas leaks before lighting the fireplace for the first time. When checking for leaks do not use open flame.

This appliance and its individual shut off valve must be disconnected from gas supply piping system during any pressure testing of that system at test pressures more than ½ psig (3.5 kPa). This appliance must be isolated from the gas supply piping system by closing its individual manual shut off valve during any pressure testing of the gas supply piping system at test pressures equal to or less than 1/2 psig (3.5 kPa).

- Move the appliance into position and secure it to the wall using the back or side mount.
- Install a manual gas valve before the connection to the fireplace appliance automatic valve.
- Connect the gas line to the fireplace. The appliance is designed to accept a 1/2" (13mm) gas supply.
- Connect the gas supply in accordance with local codes, CAN/CSA-B149.1 in Canada or to the current National Fuel Gas Code, ANSI Z223.1 / NFPA 54 in the United States.
- Check for gas leaks using non-corrosive commercially available leak-check solution before operating the gas appliance.
- Measure and document gas pressure here: Inlet \_\_\_\_\_ W.C. Burner (Manifold) \_\_\_\_\_ W.C. -- Make sure the Min/Max inlet pressure match the table below.
- Lighting the fireplace for the first time may take some time until the line is purged.

Gas Pressure	Natural Gas	Propane
Inlet pressure	7.0" W.C	10". W.C

**\*Do not place gas valve above the burner line of the fireplace\***

**WARNING!** Risk of Fire or Explosion! High pressure will damage the valve. Low pressure could cause an explosion.

**Verify inlet pressures** - Verify minimum pressures when other household gas appliances are operating



# FLARE

## FIREPLACES

### SIT PROFLAME II GAS VALVE LAYOUT

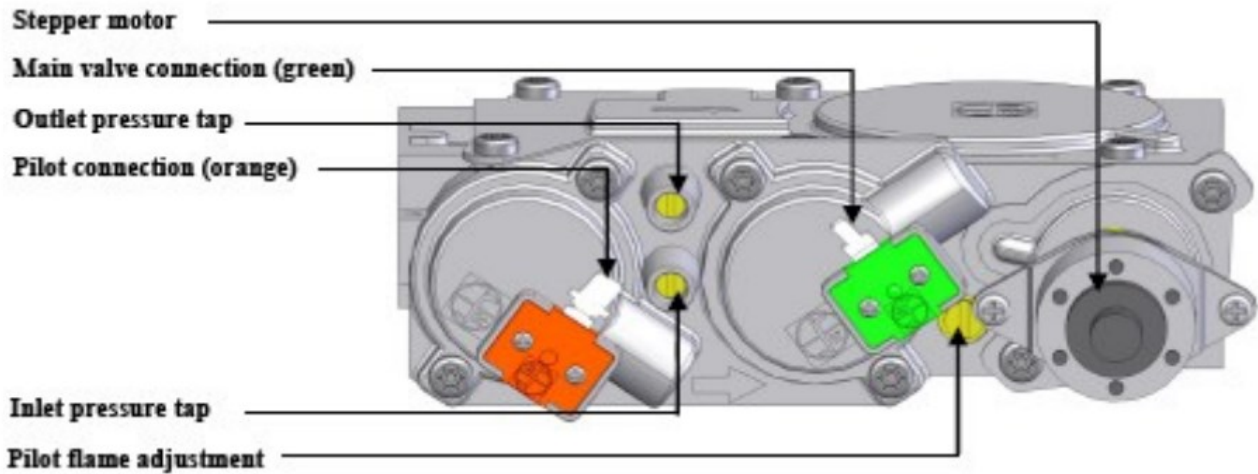

## NOTICE

Have the gas supply line installed in accordance with local codes, if any. If not available, follow ANSI 223.1. Installation should be done by a qualified installer approved and/or licensed as required by the locality (in the Commonwealth of Massachusetts installation must be performed by a licensed plumber or gas fitter).

# FLARE

## FIREPLACES

### USING A REDUCER TO DE-RATE YOUR FLARE FIREPLACE

Flare Fireplaces appliances use the SIT ProFlame II System valve and are tested/approved for installations at elevations of 0–4500 feet (0–1372 meters) above sea level using the standard burner orifice sizes. At the time of installation, it must be determined by the installer if the appliance needs to be de-rated for elevations above 4500 feet. Contact your local gas supplier for the de-rating requirements in your area. Only use the Flare Fireplaces de-rating reducer on installations above 4500 Ft. If the installer must convert the unit to adjust for varying altitudes, the information sticker must be filled out by the installer and adhered to the appliance at the time of conversion.

#### DE-RATE TABLE

MODEL	GAS TYPE	REDUCER SIZE	CALC BTU.	STANDARD BTU
30"	LPG	1.6 mm	18000	23000
45"	LPG	1.9 mm	22000	28000
50"	LPG	2.0 mm	27000	35000
60"	LPG	2.2 mm	36000	43000
70"	LPG	2.5 mm	38000	45000
80"	LPG	2.7 mm	42000	49000
100"	LPG	2.9 mm	51000	57000
30"	NG	3.0 mm	27000	33000
45"	NG	3.2 mm	30000	36000
50"	NG	3.5 mm	35000	45000
60"	NG	3.8 mm	40000	51000
70"	NG	4.1 mm	44000	52000
80"	NG	4.5 mm	48000	55000
100"	NG	4.7 mm	49000	57000

# FLARE FIREPLACES

## ADDING THE FLARE FIREPLACES DE-RATING REDUCER

Add the de-rating reducer when your fireplace is being installed at elevations over 4500 ft above sea level. Please contact your local gas supplier for de-rating requirements in your area.

1. Shut off gas, remove power, and locate your gas valve. Once disconnected, verify direction of gas flow by locating the flow-arrow on top of the valve. Turn off gas and remove hard line to valve. **SEE EXAMPLE 1**

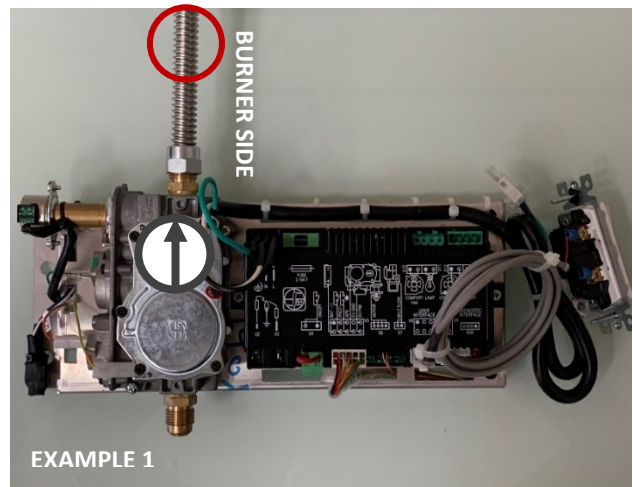

2. Add reducer between gas hard line and flex line connected to SIT ProFlame II valve on the burner side. Use appropriate reducer as specified in "DE-RATE TABLE". **SEE EXAMPLE 2**

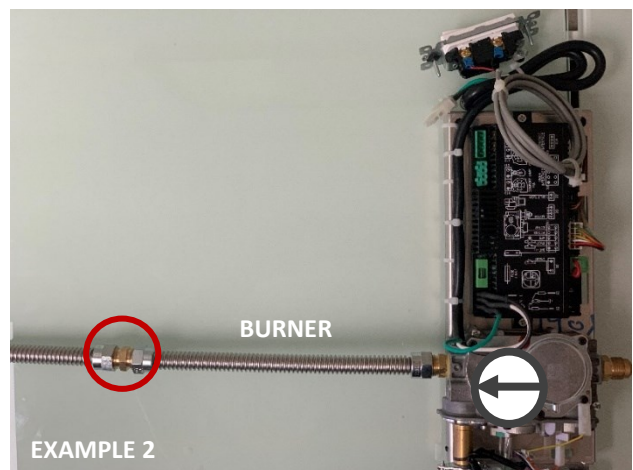

# FLARE FIREPLACES

## ORIFICE SIZE

Flare Fireplace appliances are tested and approved for installations at elevations of 0–4500 feet (0–1372 meters) above sea level using the standard burner orifice sizes. At the time of installation, it must be determined if the appliance needs to be de-rated. Contact your local gas supplier for deration requirements for your area. De-rated installation consideration can start at 2000 Ft above sea level. At higher elevations, the amount of BTU fuel value delivered must be reduced by either using gas that has been de-rated by the gas company or by changing the burner orifice to a smaller size as regulated by the local authorities that have jurisdiction and by the (USA) National Fuel Gas Code NFPA 54/ANSI Z223.1 - latest edition or in Canada, the CAN/CSA-B149.1 code – latest edition.

## GAS VALVE ACCESS DOOR

The Flare Fireplace gas valve and control system is on an “umbilical cord” that can be stretched up to 50” from the middle of the fireplace and be put next to the access door location. **Do not place the gas valve or controls above the level of the burner.** If the fireplace is to sit low on the floor, the controls must be placed outside the non-combustible zone or insulated from the heat from the fireplace. The access door can be placed on any side of the fireplace, below the non-combustible line. The use of a 10”x10” access door is highly recommended. If no access door is installed, it is possible to access the gas valve from inside the fireplace by removing the glass. The access door can also be used as a lower air intake for a double glass installation if it is perforated, and the opening requirements are maintained. The access door can be concealed in many ways such as HVAC vent cover, removable tile connected with Velcro straps and more.

## MANUAL GAS SHUT OFF

The installation of this appliance **REQUIRES** the implementation of a readily accessible Manual Gas Shut Off. Confirm requirements of location and shut off type with your local codes. **NOTE:** The Electronic Ignition of Flare Fireplaces **DOES NOT** satisfy the requirement for a Manual Gas Shut Off. See below for example of Manual Gas Shut Off



# FLARE FIREPLACES

## LIQUID PROPANE USAGE IN A FLARE FIREPLACE

The Flare Fireplace can operate and fire using Natural Gas (Default) or Liquid Propane gas. If your installation requires the fireplace to operate using Liquid Propane gas, make sure only to use the Flare Fireplaces liquid propane conversion kit.

Depending on your fireplace ignition system, LPG conversion kit may include the following:

- LPG burner orifices
- Pilot LPG orifices
- SIT ProFlame II Valve LPG Conversion Kit

**NEVER OPERATE A FIREPLACE ORDERED FOR NATURAL GAS WITH LP GAS UNLESS CONVERTED BY A CERTIFIED FIREPLACE TECHNICIAN. USE ONLY FLARE FIREPLACE LP CONVERSION KIT. ALWAYS MEASURE GAS INLET PRESSURE AND OUTLET PRESSURE POST CONVERSION**

Your Fireplace may be shipped to support Liquid Propane Gas. Check your Flare Fireplaces gas rating plate at the back of your valve to confirm the gas type.

## NOTICE

Flare Fireplaces does offer the ability to run your fireplace with a liquid propane tank though there are certain limitations this fuel type presents when compared to the usage of natural gas. Liquid propane burns more efficiently and hotter than natural gas so to accommodate this increase in heat we must use smaller orifices to achieve a lower BTU that can cause your flame to appear smaller than on a unit run on natural gas. Flame height on Flare Fireplaces using Liquid Propane is roughly 4-6" in height because of this adjustment.

---

## COMMONWEALTH OF MASSACHUSETTS

### State of Massachusetts Carbon Monoxide

Detector/Vent Terminal Signage Requirements for all side wall horizontally vented gas fueled equipment installed in every dwelling, building or structure used in whole or in part for residential purposes, including those owned or operated by the Commonwealth and where the side wall exhaust vent termination is less than seven (7) feet above finished grade around the venting, including but not limited to decks and porches, the following requirements shall be satisfied:

1. **INSTALLATION OF CARBON MONOXIDE DETECTORS.** At the time of installation of the side wall horizontal vented gas fueled equipment, the installing plumber or gas fitter shall observe that a hard-wired carbon monoxide detector with an alarm and battery back-up is installed on the floor level where the gas equipment is to be installed. In addition, the installing plumber or gas fitter shall observe that a battery operated or hard-wired carbon monoxide detector with an alarm is installed on each additional level of the dwelling, building or structure served by the side wall horizontal vented gas fueled equipment. It shall be the responsibility of the property owner to secure the services of qualified licensed professionals for the installation of hard-wired carbon monoxide detectors.
  - a. If the side wall horizontally vented gas fueled equipment is installed in a crawl space or an attic, the hard-wired carbon monoxide detector with alarm and battery back-up may be installed on the next adjacent floor level.
  - b. If the requirements of this subdivision cannot be met at the time of completion of installation, the owner shall have a period of thirty (30) days to comply with the above requirements; provided, however, that during said thirty (30) day period, a battery-operated carbon monoxide detector with an alarm shall be installed.
2. **APPROVED CARBON MONOXIDE DETECTORS.** Each carbon monoxide detector as required in accordance with the above provisions shall comply with NFPA 720 and be ANSI/UL 2034 listed as IAS certified.
3. **SIGNAGE.** A metal or plastic identification cation plate shall be permanently mounted to the exterior of the building at a minimum height of eight (8) feet above grade directly in line with the exhaust vent terminal for the horizontally vented gas fueled heating appliance or equipment. The sign shall read, in print size no less than one-half (1/2) inch in size, "GAS VENT DIRECTLY BELOW. KEEP CLEAR OF ALL OBSTRUCTIONS".
4. **INSPECTION.** The state or local gas inspector of the side wall horizontally vented gas fueled equipment shall not approve the installation unless, upon inspection, the inspector observes carbon monoxide detectors and signage installed in accordance with the provisions of 248 CMR 5.089(2)(a) 1 through 4.

(b) **EXEMPTIONS.** The following equipment is exempt from 248 CMR 5.089(2)(a) 1 through 4.

# FLARE

## FIREPLACES

---

5. The equipment listed in Chapter 10 entitled “Equipment Not Required to Be Vented” in the most current edition of NFPA 54 as adopted by the Board; and
6. Product Approved side wall horizontal vented gas fueled equipment installed in a room or structure separate from the dwelling, building or structure used in whole or in part for residential purposes.

(c) MANUFACTURER REQUIREMENTS – GAS EQUIPMENT VENTING SYSTEM PROVIDED. When the manufacturer of Product Approved side wall horizontally vented gas equipment provides a venting system design or venting system components with the equipment, the instructions provided by the manufacturer for installation of the equipment and the venting system shall include:

7. Detailed instructions for the installation of the venting system design or the venting system components; and
8. A complete parts list for the venting system design or venting system.

(d) MANUFACTURER REQUIREMENTS – GAS EQUIPMENT VENTING SYSTEM NOT PROVIDED. When the manufacturer of a Product Approved side wall horizontally vented gas fueled equipment does not provide the parts for venting the fuel gases, but identifies “special venting systems”, the following requirements shall be satisfied by the manufacturer.

9. The referenced “special venting system” instructions shall be included with the appliance or equipment installation instructions; and
10. The “special venting systems” shall be Product Approved by the Board, and the instructions for that system shall include a parts list and detailed installation instructions.

(e)) A copy of all installation instructions for all Product Approved side wall horizontally vented gas fueled equipment, all venting instructions, all parts list for venting instructions, and/or all venting design instructions shall remain with the appliance or equipment at the completion of the installation.

# FLARE FIREPLACES

## TELEVISION MOUNTING ABOVE THE FIREPLACE

The Flare Fireplace frameless design directs the heat from the fireplace into the fireplace chase to be released from the top vent opening. The design allows for a relatively low temperature on the external wall above the fireplace which allows you to mount a TV or art piece as close as 12" from the glass opening, regardless of size, style, or safety barrier selected.

Follow the charts and instruction below for suggested installation of a television above the fireplace.

- Please note that the electric wiring used for the television must be insulated when installed inside the chase above the fireplace.
- It is critical that wiring insulation **does not** obstruct the hot air flow from going to the top part of the chase to be released back to the room.
- Placing insulation above the fireplace may result in a Fire hazard. The air flow above the fireplace should remain open to allow heat to be released from the top of the chase.
- Follow the chart below for clearance and sizing.
- **It is recommended to double wall** the area behind the TV to allow cables and other related material to be installed with less concern of blocking hot air flow. Use non-combustible material for double wall.
- All wires **MUST** be secured and anchored to the frame to prevent any possibility of wires dropping on top of the Fireplace.
- TV can be recessed when installed above the Fireplace, be protected by a mantel or flush installed above the fireplace.
- Wires should be inserted into the recess from the top or sides (In order to avoid proximity to the fireplace vent).
- To reduce the amount of heat around and below the TV, **increase** the size of the heat release **above the minimum** required for your fireplace size unit.

## WARNING!

\*Please note that most television manufacturers and manuals will instruct the owner **not to install** television above or near a fireplace. Mounting a television above the fireplace is based on the owner's decision and responsibility. Flare will not be held liable for any adverse effects on a TV, artwork or other equipment located near the Flare appliance. It is the customer's responsibility to verify that their TV or artwork can withstand the wall temperatures at the installation site.



# FLARE FIREPLACES

## TV INSTALL – FLAT EXAMPLE

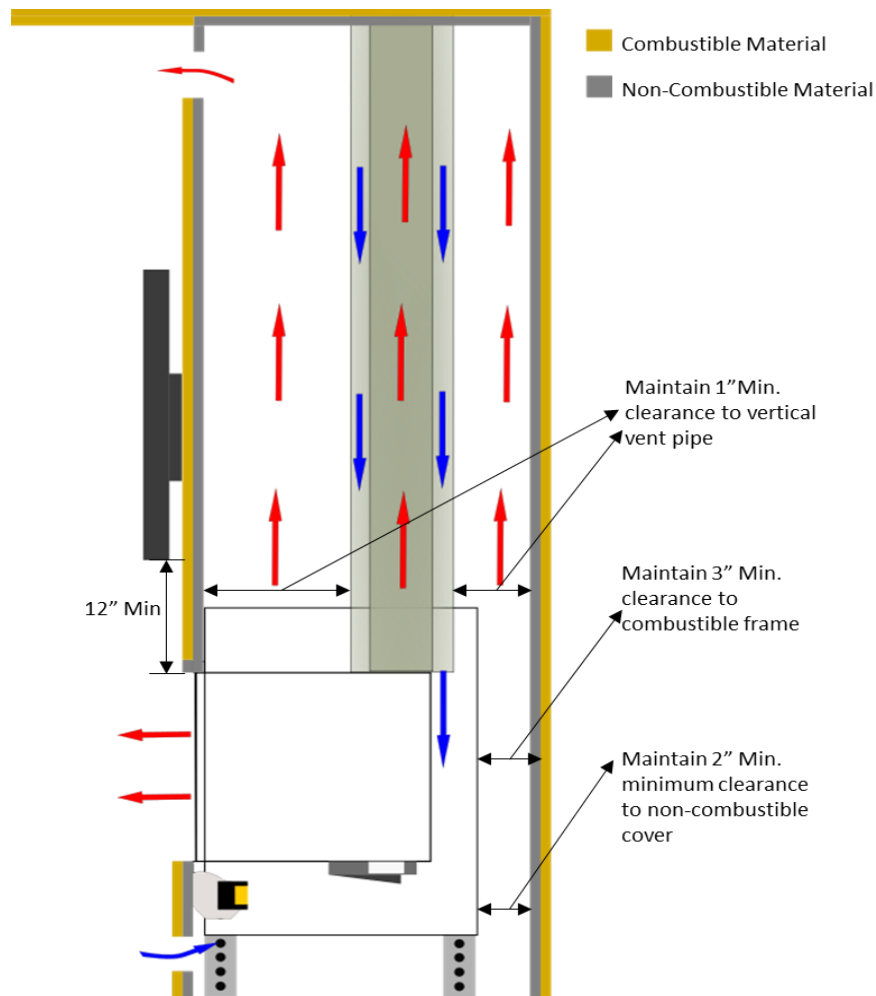

\*The example above is not an exact rendering of every fireplace style and vent placement offered by flare but is meant to convey clearances for use on all unit installations. For exact drawings of the fireplaces and their vent placement download dimension or framing guides [here](#).

## WARNING!

Maintain Open Air flow between the fireplace and drywall. Make sure cables or any other materials are not blocking hot air flow.

# FLARE FIREPLACES

## TV INSTALL – RECESSED WITH FIREPLACE OVERHANG

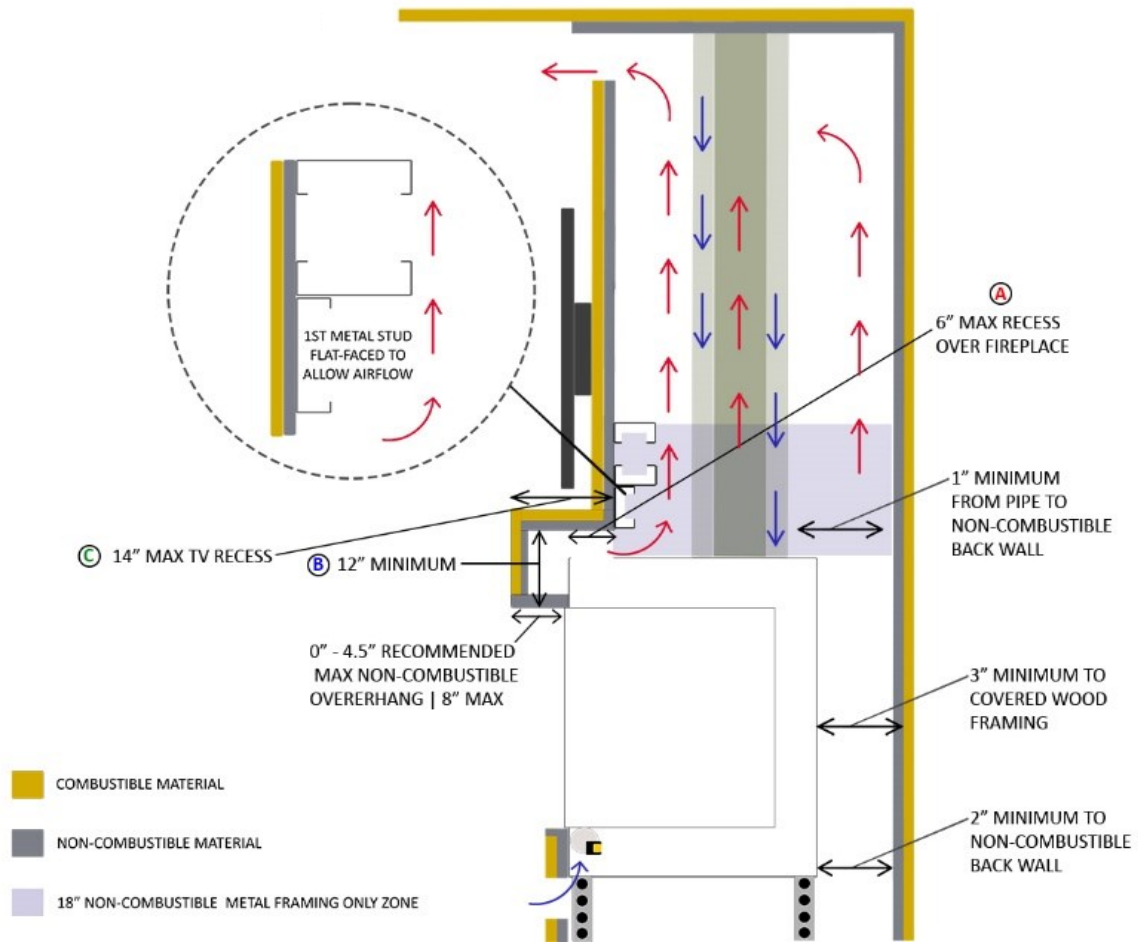

- A. Directly over the fireplace the television recess should be no deeper than 6" inches.
- B. A minimum of 12" above the top of the fireplace glass opening to the underside of the recess.
- C. Extending the overhang to the max of 8" and recessing into the cavity to the max of 6" can create an overhang up to 14" deep.

## WARNING!

Use non-combustible framing and finishing materials only for overhang construction, finishing materials may not extend into the glass installation zone. See an example of this above. Do not recess any deeper than 14" from the face of your finishing material to the back of the recess, as it will damage the TV.

# FLARE

## FIREPLACES

---

\*The example above is not an exact rendering of every fireplace style and vent placement offered by flare but is meant to convey clearances for use on all unit installations. For exact drawings of the fireplaces and their vent placement download dimension or framing guides [here](#).

### WARNING!

Maintain Open Air flow between the fireplace and drywall. Make sure cables or any other materials are not blocking hot air flow.

---

#### 45-DEGREE ELBOW ON TOP OF FIREPLACE TO MAINTAIN CLEARANCE TO RECESS

When planning a TV recess, clearance to the vent pipe in the chase is critical and needs to be a minimum of 1" to the non-combustible recessed wall. This is to prevent heat from radiating from the vent to the recessed wall and being transferred to the TV. Due to the central location and diameter of the vent (8 inches) on our front facing & see-through models, one of the following solutions may be necessary to maintain the clearance requirement:

1. The television recess should be no more than 6" inches deep, **12" above the top of the fireplace glass opening**. You must maintain a 1" clearance from your recess to the vent pipe to prevent overheating.
2. Install two 45 elbows directly above the fireplace followed by a minimum 4 ft vertical vent rise. The two small elbows will move the vertical section back 5 5/8". Note that the 1-inch clearance from the vent applies also to the back non-combustible wall.
3. Do not use any elbow with an angle larger than 45 degrees.
4. A **4 ft** minimum vertical vent rise must be used after the **two 45-degree** elbows on fireplaces sized between **30"** and **70"**. A **6 ft** minimum rise will be required for units sized at **80"** and **100"**.
5. **Note: Max recess of TV into the cavity should not exceed 6"**. Recesses exceeding this dimension run the risk of creating a shelf and hindering air flow above unit, resulting in a wall that may overheat.
6. **The following vent path should be used for Flare Front and Flare See Through only.**

# FLARE

## FIREPLACES

4x6		5x8	
Offset	Rise	Offset	Rise
5"	13 1/2"	5 5/8"	15 3/8"

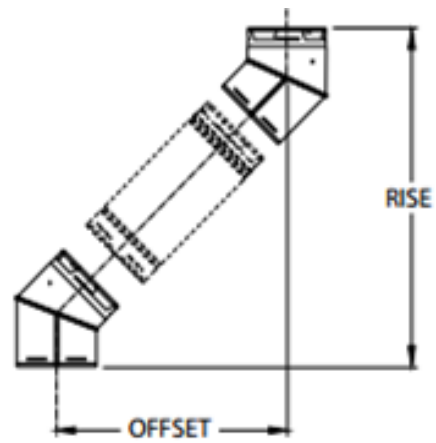
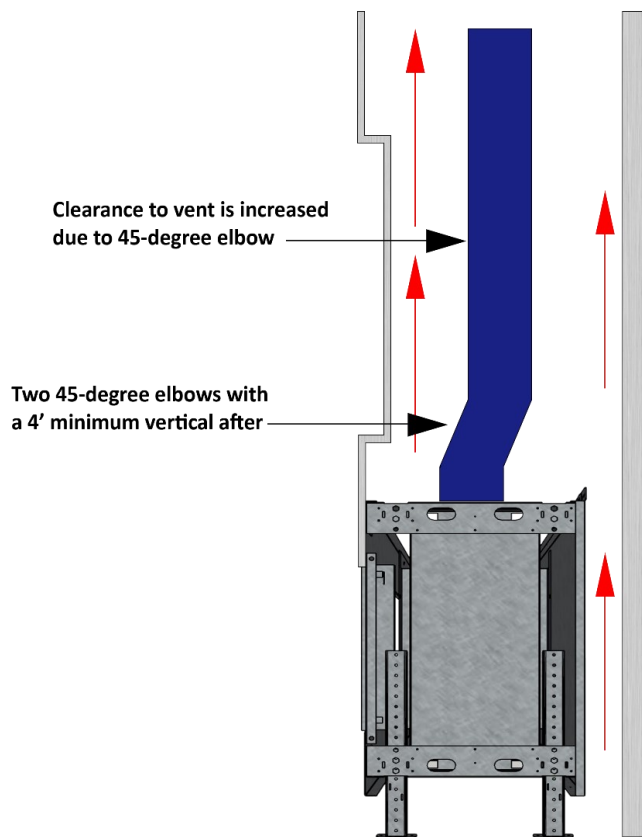

# FLARE FIREPLACES

## TV INSTALL – NO RECESS WITH MANTEL

Minimum Requirements for Installing a Television without a Recess:

- The TV must be at least 11 Inches total above the glass of the fireplace.
- The mantel must be at least 1 inch thick, 6 inches deep, and be installed a minimum of 8 inches above the glass.
- The TV must be at least 2 inches above the mantel and 1 inch back from the edge of the mantel.
- To reduce the amount of heat around and below the TV, increase the size of the heat release above the minimum.
- All measurements shown are minimum requirements.

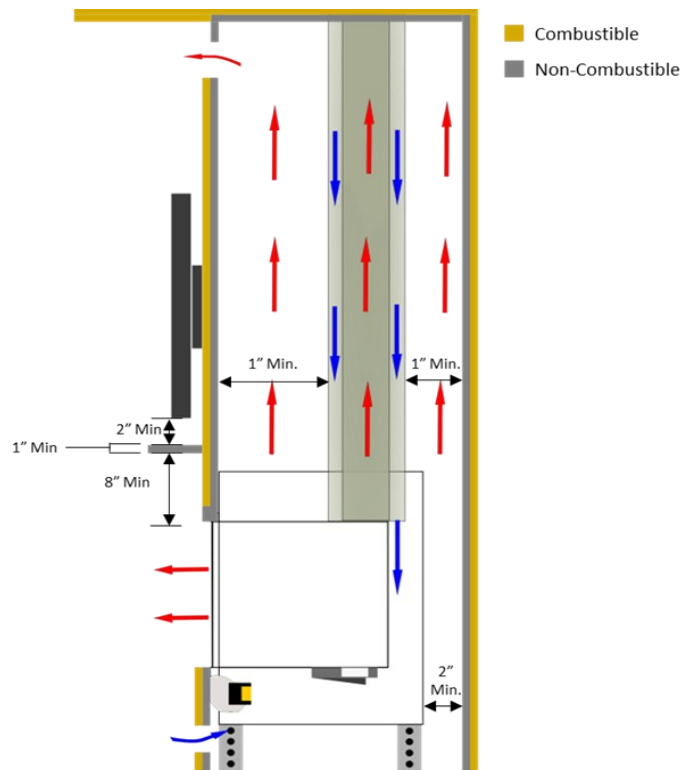

\*The example above is not an exact rendering of every fireplace style and vent placement offered by flare but is meant to convey clearances for use on all unit installations. For exact drawings of the fireplaces and their vent placement download dimension or framing guides [here](#).

## WARNING!

Maintain Open Air flow between the fireplace and drywall. Make sure cables or any other materials are not blocking hot air flow.

# FLARE FIREPLACES

## FRAMING SPECIFICATIONS

### METAL FRAMING

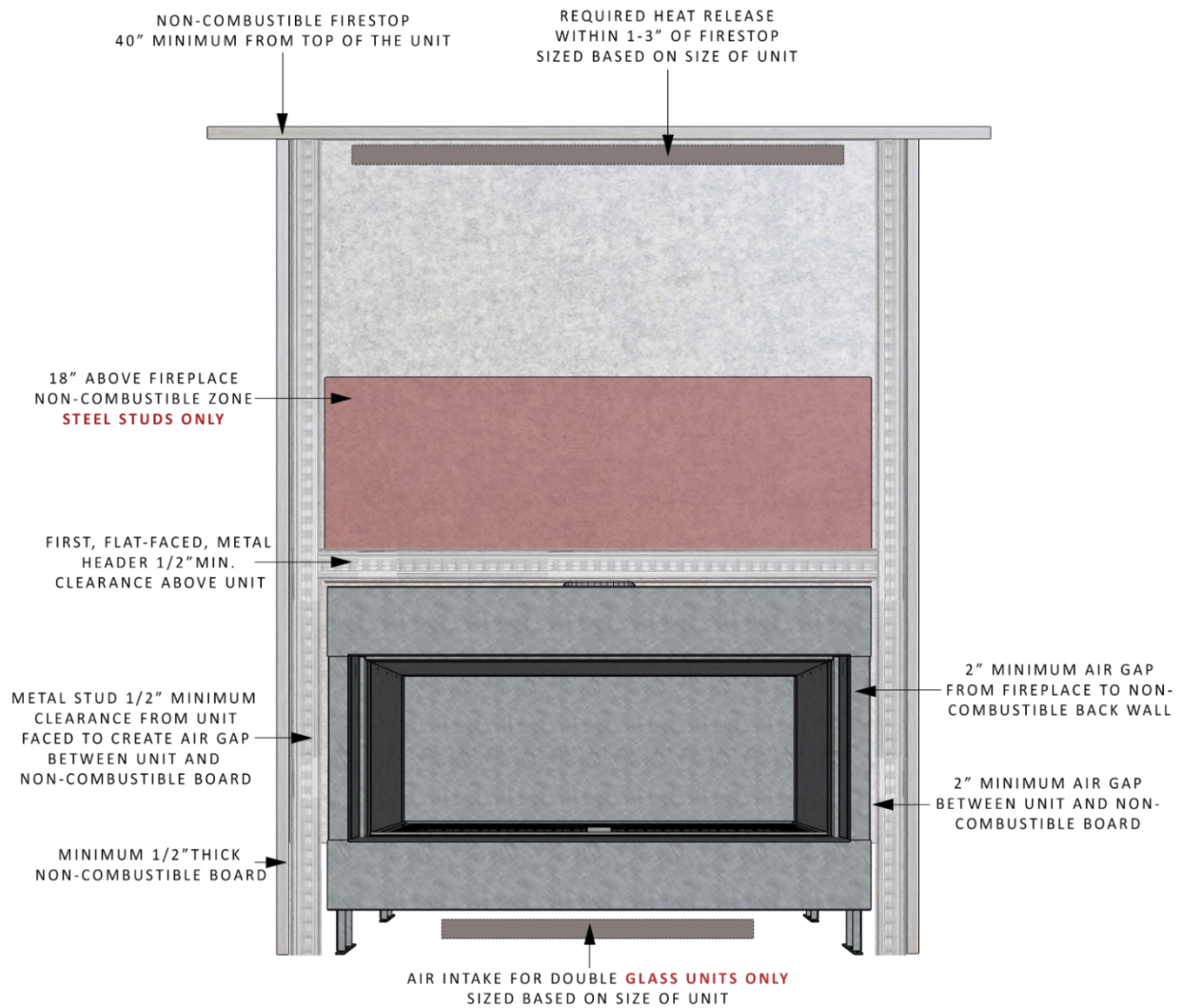

## NOTICE

For more detailed framing information please refer to your unit specific framing guide

# FLARE FIREPLACES

## WOOD FRAMING

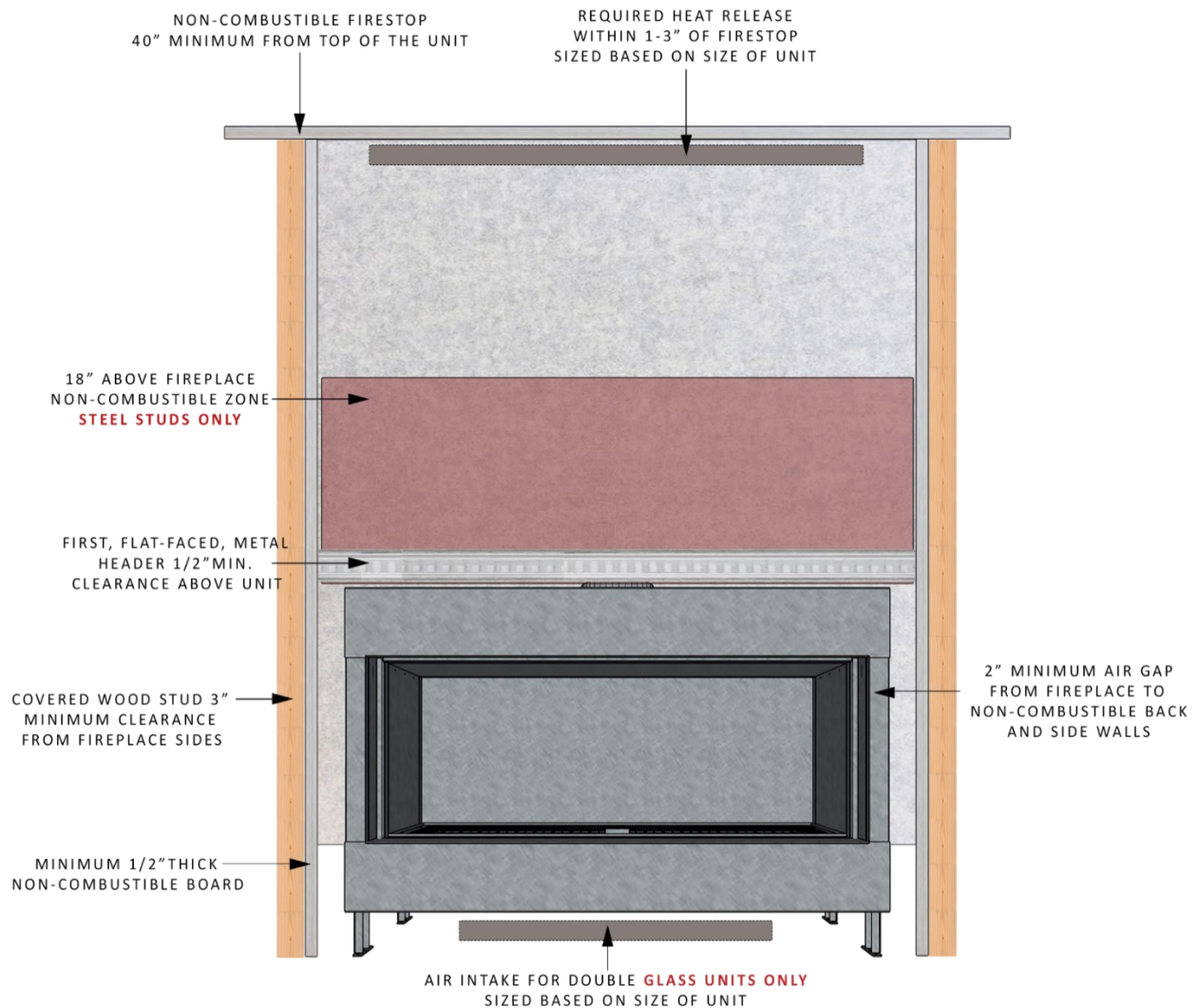

## NOTICE

For more detailed framing information please refer to your unit specific framing guide

# FLARE

## FIREPLACES

### FIREPLACE CLEARANCES

1. **Floor Clearance** – The minimum clearance from the floor to the fireplace is 3 inches. The fireplace comes with telescopic legs pre-set to 4 inches but can be adjusted down by 1 inch to meet the minimum clearance. The unit can also be recessed into the floor, provided all other clearance and installation requirements are met.

**NOTE:** Install appliance on hard metal, cement board, drywall, or wood surfaces, extending full width and depth.

**WARNING!** - DO NOT install directly on carpeting, vinyl, or any combustible material other than wood.

2. **Glass Front Clearance** – Keep all furniture and combustible objects at least 36 inches away from the glass front of the appliance.
3. **Clearance to Metal Stud Framing** – A minimum clearance of 1/2 inch is required from metal framing. If a header is necessary within the first 18" above the fireplace, it must be made of metal framing.
4. **Direct Vent Pipe Minimum Clearances to Combustibles** –

- **Horizontal Run:** Horizontal vent runs must maintain a minimum clearance of 3 inches at the top and 1 inch at the sides and bottom from combustibles. Additionally, the vent pipe must have a minimum rise of 1/4 inch (6 mm) per foot towards the termination.
- **Vertical Rise:** Vertical vent runs must maintain a minimum of 1 inch (25mm) around the vent pipe on all vertical runs, to combustibles, is required. Except for clearances in appliance enclosures.

**WARNING!** - Never allow the vent to run downward. A downward slope can trap heat and become a possible fire hazard.

**WARNING!** Maintain vent clearance to combustibles as detailed above. DO NOT pack air space with insulation or other materials. Failure to keep insulation or other materials away from vent pipe could cause overheating and fire.

**WARNING!** Flare fireplaces are not designed to be load bearing or support weight of any architectural framing. All framings should be self-supported, supported by back wall, side wall, or ceiling. Mounting the framing to a fireplace subjects' glass to unsupported weight and could result in damage to fireplace. Improper framing or mounting to unit will void product warranty. Please consult Flare Fireplaces directly for additional questions or concerns about framing options.



# FLARE

## FIREPLACES

5. **Combustible Mantel Clearance** – Combustible mantel clearance can vary per mantel size and location. Use chart and provided table for information on mantel installation. Do not anchor any mantel or shelf to the fireplace. Only use metal studs above the fireplace as anchor points.

REF	Height	Mantel Depth
A	2"	1"
B	4"	4"
C	6"	6"
D	10"	12"

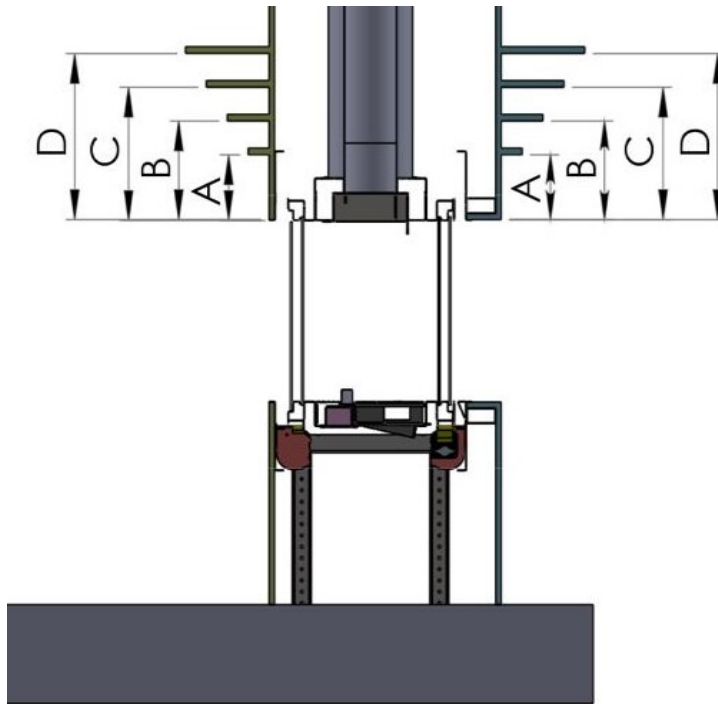

### NOTICE

\*Non-combustible mantels do not have a minimum clearance to the fireplace opening and can be brought as close to the glass as allowed by the frame of the fireplace. Please keep in mind any material used could potentially heat up dramatically the closer to the fireplace you bring it and the longer the fireplace is on.

# FLARE

## FIREPLACES

---

6. **Fireplace Shelf Enclosure** – The minimum height to the inside of a shelf above the top of the fireplace is 6 inches (**12 inches above the glass**). This shelf must be built with non-combustible material at least 5/8" thick. Due to the low size of the shelf enclosure, it is recommended to build the enclosure using Skamol board. The Skamol board is a light non-combustible material that can help prevent the formation of cracks and is a good insulator. \*The shelf enclosure **MUST** have a heat release opening centered on top of your shelf, and on the front or back of the longest face of the surround, doubling the opening requirement seen when using standard floor to ceiling surround. See example below



**NOTE:** You may avoid a top release, when at least doubling the minimum heat release requirement by creating an opening that releases heat from all sides of the shelf-enclosure.

- A. Required heat release on top of shelf enclosure, sized based on size of the fireplace. [Heat Release Specification Manual](#)
- B. 12" minimum from glass opening to underside of non-combustible board within shelf enclosure.

### WARNING!

\*Room Definer fireplaces, depending on the surround configuration, may require an additional heat release to alleviate heat build-up caused by the vent pipe. Please contact Flare Fireplaces at 1 (866) 639-1590 to verify your application is safe.

# FLARE

## FIREPLACES

7. **Ceiling Clearance-** The minimum ceiling height for a Flare Fireplace is 40" above the top of the fireplace.

**WARNING!** The heat released above the fireplace is critical for keeping the chase and surrounding walls at a relatively low temperature.

8. **Minimum Clearance From Non-Combustible to Fireplace Sides and Back** – The minimum clearance from the back and sides of the fireplace to any **non-combustible** material (i.e., cement board or Type X fire rated board) is 2 inches. This clearance allows for proper air flow.
9. **Minimum Clearance From Covered Combustible to Fireplace Sides and Back** – Combustible material at the back or sides of the fireplace, **MUST** be covered with non-combustible material that is at least ½ inch thick, and in some cases 5/8" thick. Wood studs, covered with non-combustible material, can be placed a minimum of 3" away from the side and back.

**Example:** A non-combustible cement board is placed 2 ½" inches from the back of the fireplace. The cement board used is ½" inch thick. Combustible material can be used behind cement board as it is a total of 3 inches away from the back of the fireplace and is covered with a non-combustible material.

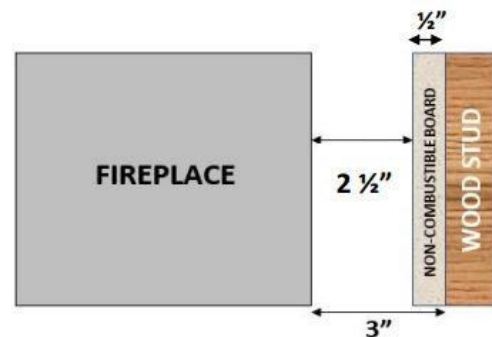

10. **Minimum Clearance From Combustible to Fireplace Sides and Back** – Clearance to uncovered combustible material at the back or sides of the fireplace, **below the non-combustible line is 8"**.
11. **Minimum Clearance Directly Above the Fireplace, Inside the Chase** – The first 18" above the fireplace is a non-combustible zone. Only non-combustible metal studs can be installed, maintaining a minimum of ½" away from the fireplace. Metal studs should not connect to or touch the fireplace. Doing so will result in heat transfer from the fireplace to the metal stud. Make sure not to block hot air flow to the heat release by front facing the first metal stud in the event you are adding a header in the non-combustible zone.

# FLARE

## FIREPLACES

### 12. Minimum Clearance Above the Fireplace Non-Combustible Zone, Inside the Chase –

**Zone A:** First 18” directly above the fireplace **MUST** be framed using metal studs if adding a header.

**Zone B:** All combustibles above the 18” must be covered with non-combustible board. There should be no combustible materials left uncovered above the fireplace inside the chase. Fireplace chase should be designed and built to allow hot air to be released from the unit and rise-up in a non-combustible channel to the heat release.

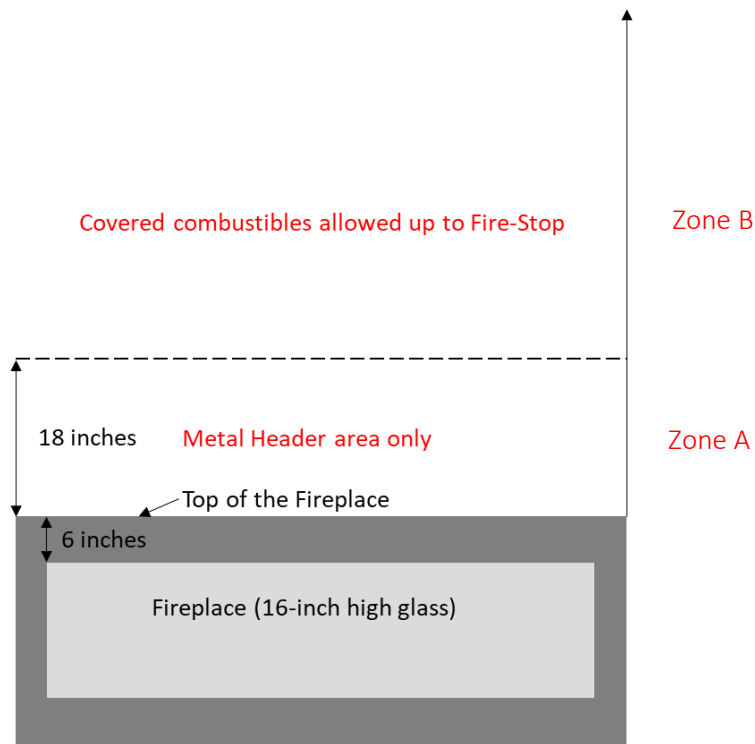

### 13. Chase Ceiling – Top of the chase (Firestop) must be covered with noncombustible material. No exposed combustible materials are allowed inside the chase.

# FLARE

## FIREPLACES

---

### 14. Hearth Clearances –

- A. Clearance to an **uncovered combustible hearth** below the glass is **2 inches** as seen in **EXAMPLE 1**
  - B. When bringing your hearth to glass height it must be non-combustible for the first 7” extending from the glass before any combustible material can be used to finish the hearth. As seen in **EXAMPLE 2**
15. **Adjacent Wall 1** – Distance to any adjacent side-wall must be at least 7 inches from the glass, as seen in **EXAMPLE 1**

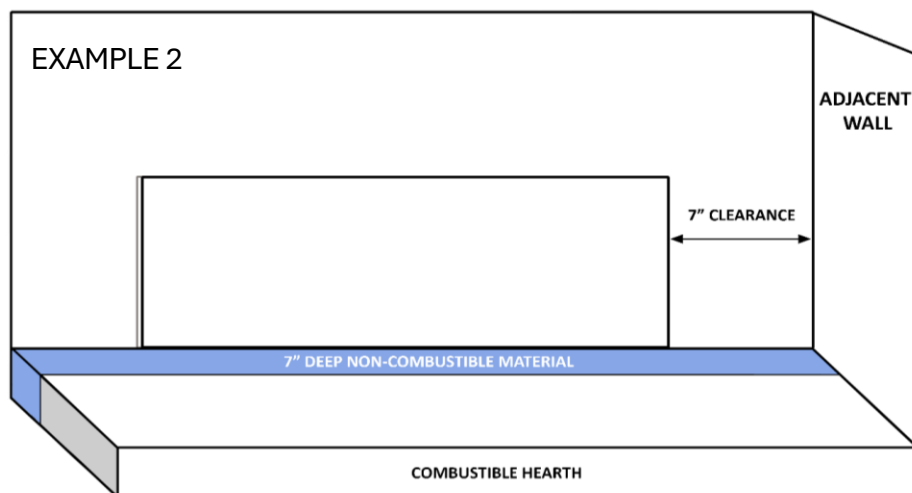
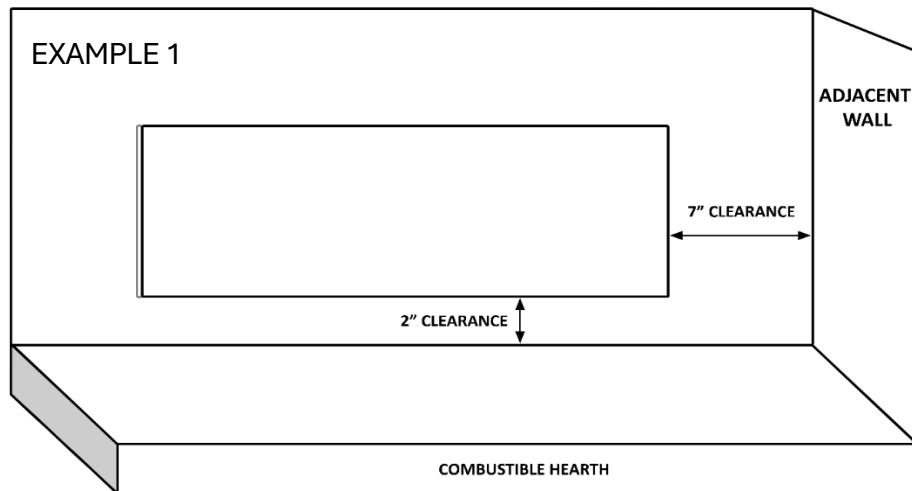

# FLARE

## FIREPLACES

16. **Finishing Around Front of Fireplace** – Non-combustible finishing material (i.e., cement board, brick, stone, and tile) **MUST** be used to finish around the front of the appliance. Covered combustible material can also be used to finish around the front of the fireplace, but only if the proper distance from the fireplace is maintained. See Examples 1, 2, and 3 below for further details

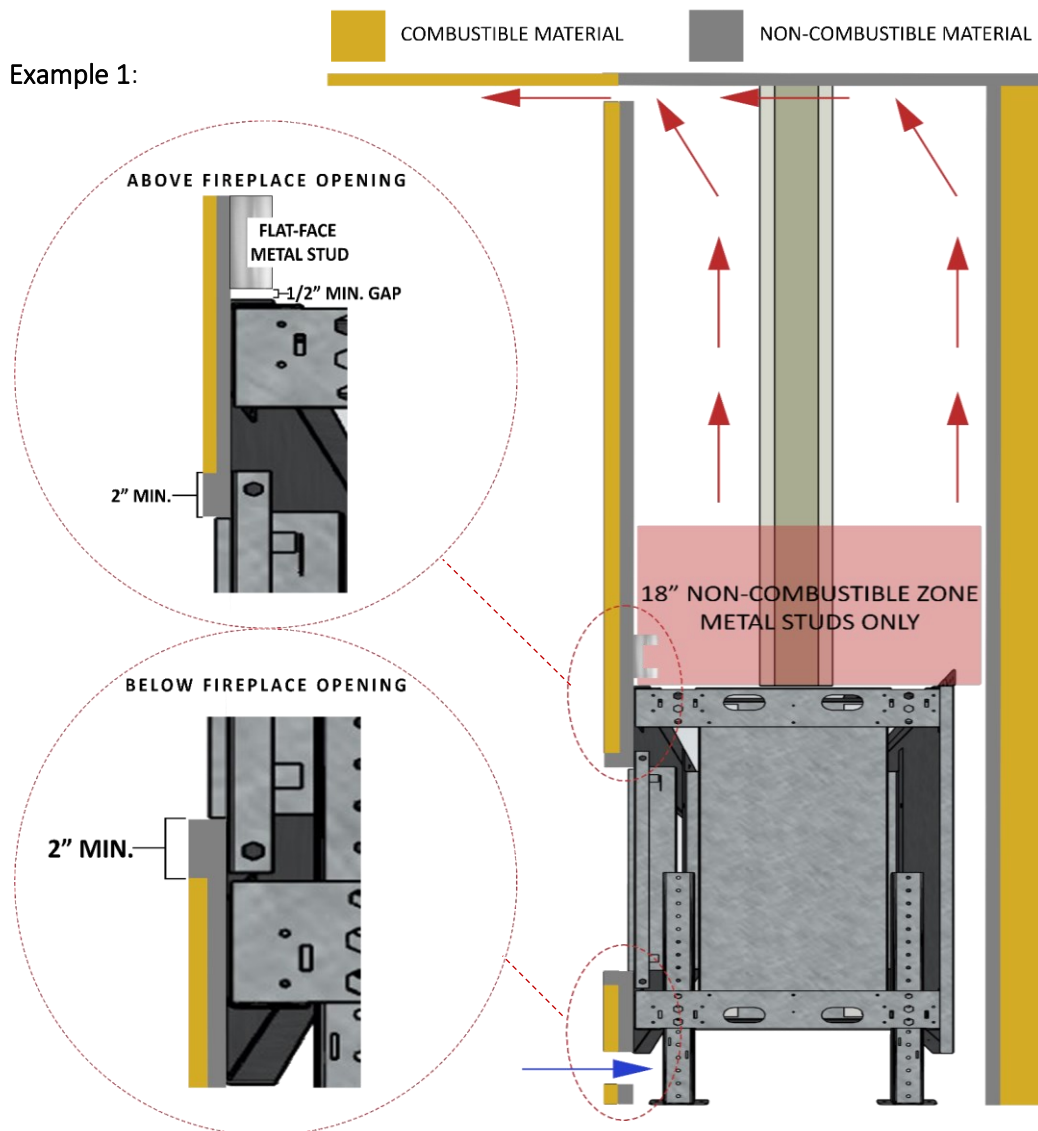

### NOTICE

Do not connect materials to or drill into the metal fireplace frame. This can result in excessive heat transfer and/or damage to the fireplace and surrounding materials.

# FLARE

## FIREPLACES

Example 2:

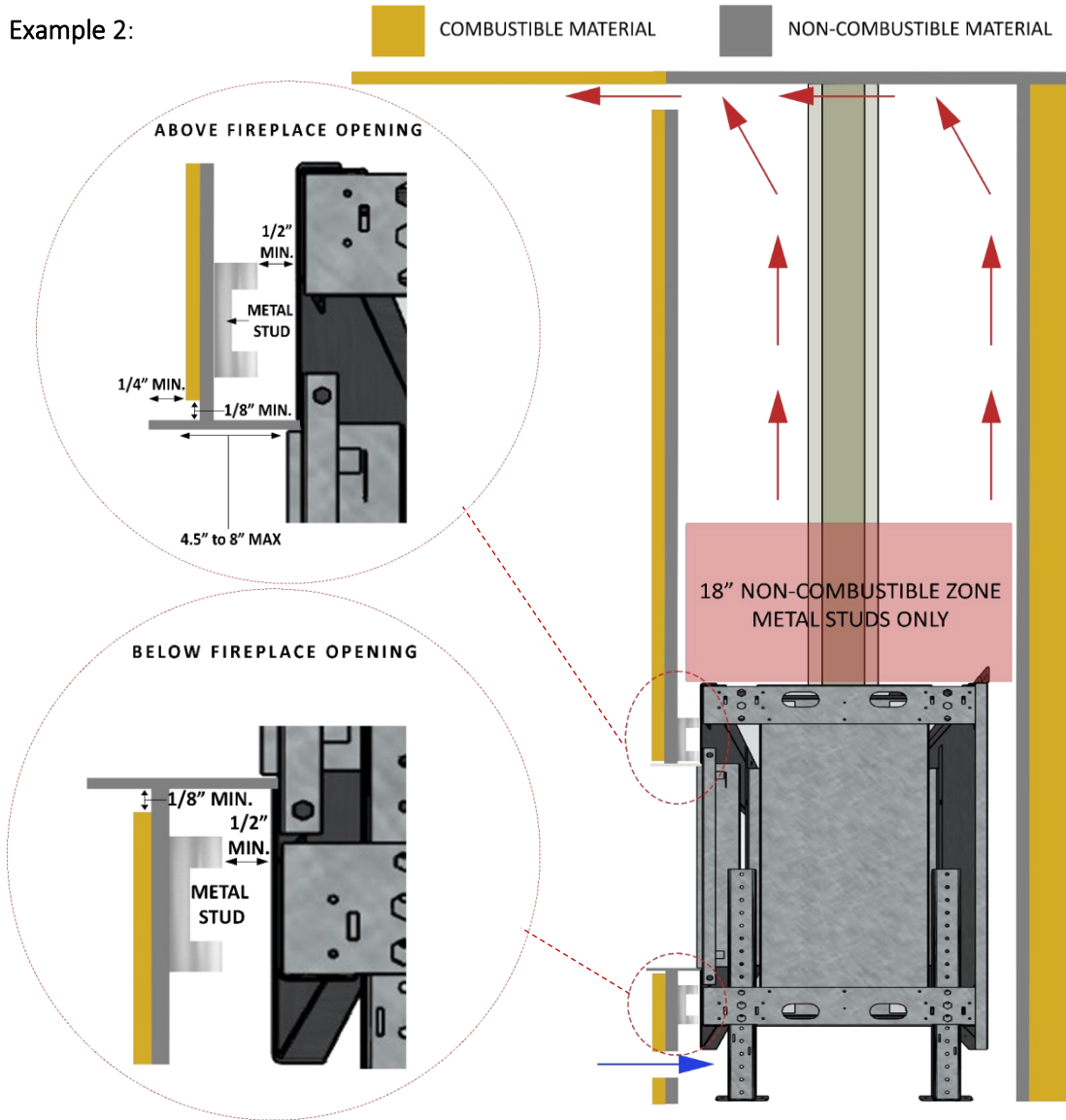

### NOTICE

Do not connect materials to or drill into the metal fireplace frame. This can result in excessive heat transfer and/or damage to the fireplace and surrounding materials.

# FLARE

## FIREPLACES

Example 3:

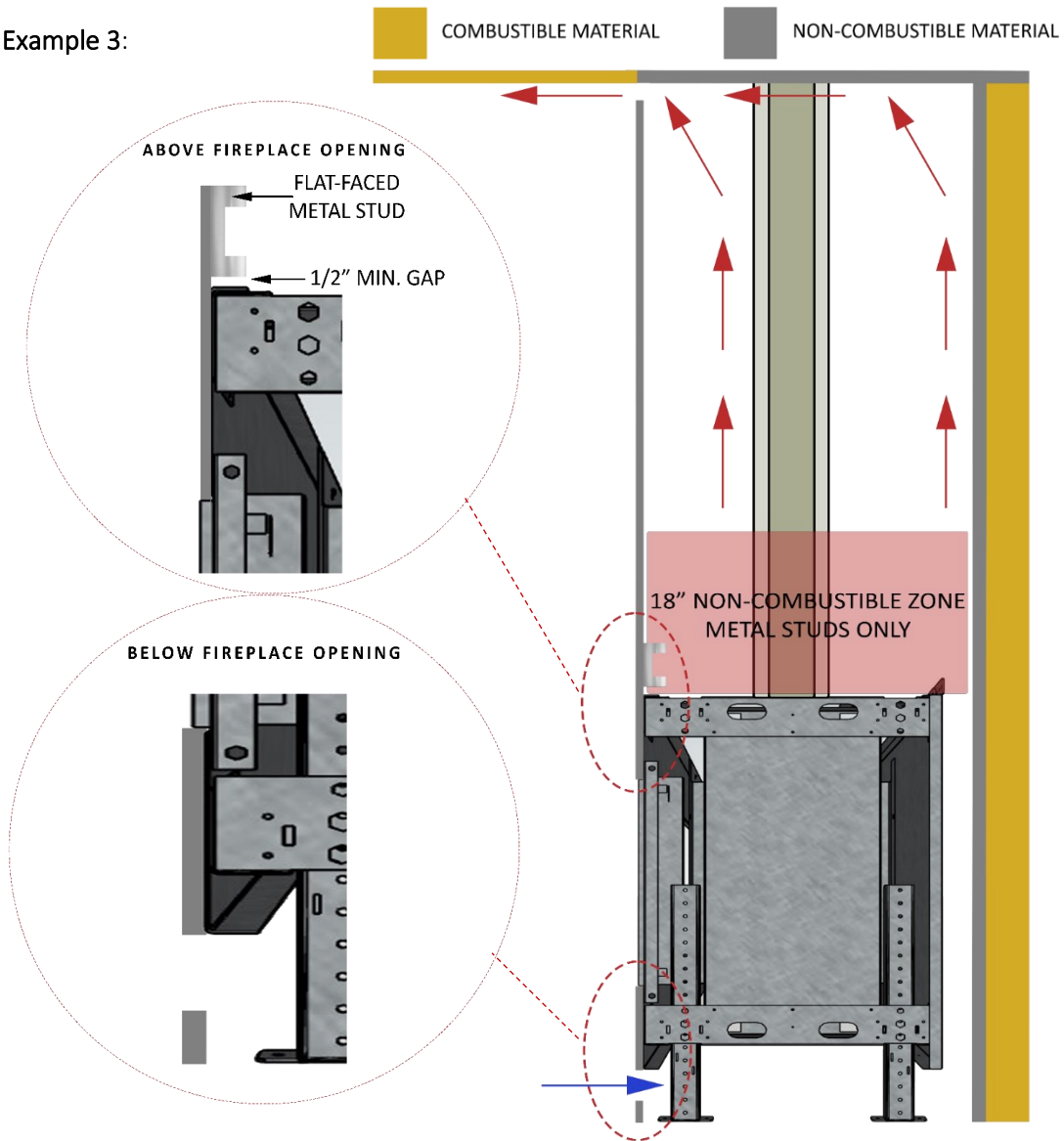

## NOTICE

Do not connect materials to or drill into the metal fireplace frame. This can result in excessive heat transfer and/or damage to the fireplace and surrounding materials.



# FLARE

## FIREPLACES

### NON-COMBUSTIBLE MATERIALS SPECIFICATIONS

#### Non-Combustible Materials Specification

Material which will not ignite and burn. Such materials are those consisting entirely of steel, iron, brick, tile, concrete, slate, glass or plasters, or any combination thereof. Materials that are reported as passing ASTM E 136, Standard Test Method for Behavior of Materials in a Vertical Tube Furnace at 750 °C shall be considered non-combustible materials. Non-combustible cement board approved must be at least 1/2" (13 mm) thick.

Non-combustible material may be installed on the fireplace frame to cover the metal part as detailed in the installation examples and clarifications only if there is no weight transfer to the fireplace. Facing and/or finishing materials must never overhang into the glass opening.

**DO NOT** connect materials to or drill into the metal fireplace frame. This can result in excessive heat transfer and/or damage to the fireplace and surrounding materials.

All joints between the finished wall sheathing and the appliance must be sealed with non-combustible materials.

**WARNING!** Risk of Fire! DO NOT apply combustible materials beyond the minimum clearances. Comply with all minimum clearances to combustibles as specified in this manual. Examples of acceptable noncombustible materials:

- Skamol Skamotec
- Promat Promafour System 1/2" 12 mm, 5/8" 15 mm, 3/4"/18 mm
- James Hardie - Hardiebacker® 1/2" 12 mm Cement Board
- 5/8" 15 mm Type X fire rated drywall.
- 1/2" 12 mm Type C fire rated drywall
- PermaBASE Cement Board 1/2" 12mm and 5/8" 15 mm

#### Combustible Materials Specification

Materials made of or surfaced with wood, compressed paper, plant fibers, plastics, or other material that can ignite and burn, whether flame-proofed or not, or plastered or un-plastered shall be considered combustible materials.

# FLARE FIREPLACES

## CLEARANCE TO A SPRINKLER

In a situation where a sprinkler head is installed within proximity to a Heat Release, the diagram below **MUST** be followed. The distance between the sprinkler head & Heat Release opening cannot be less than 60" in length at every point from the origin of the Heat Release. You must also verify the sprinkler head sensor is set to the proper heat setting so it does not activate when the room heats up from the fireplace being operated normally. **DO NOT INSTALL A SPRINKLER IN THE FIREPLACE CAVITY.** Please follow the local building code to determine what temperature setting is relevant for your installation.

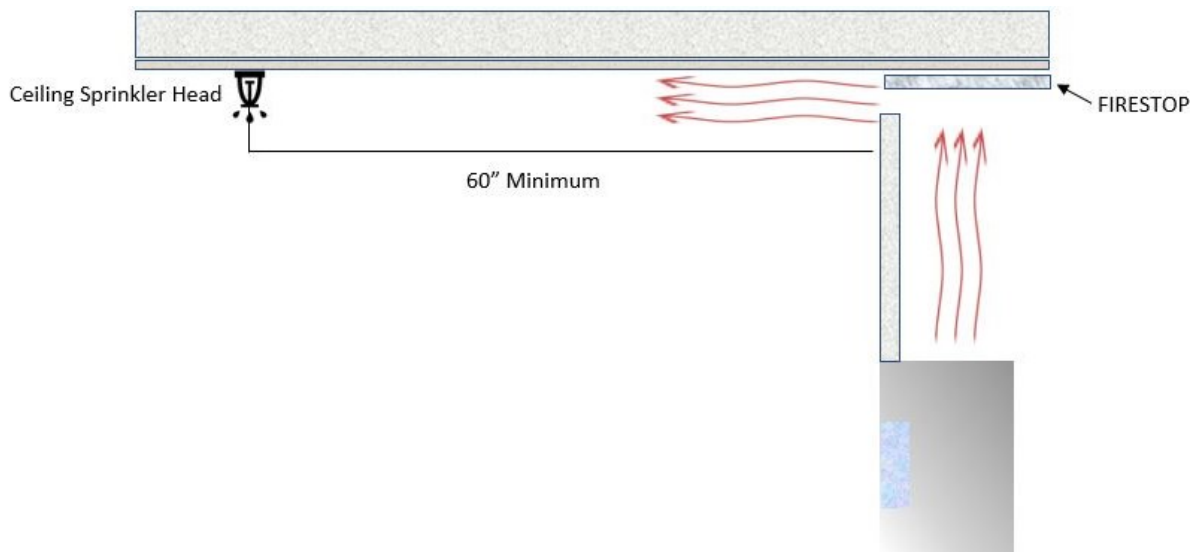

## WARNING!

Vaulted ceilings can create a channel that funnels hot air directly towards a sprinkler head placed at the proper distance from heat release, as stated above. If the sprinkler head sensor is not rated for high heat it could potentially set off the sprinkler system inadvertently. Please work with builder & inspector to verify your sprinkler system is properly set to accommodate higher temperatures & is not set up in a heat channel

# FLARE

## FIREPLACES

### HEAT RELEASE AND AIR INTAKE SPECIFICATION

For more specific information related to understanding the Heat Release and Air Intake please use the following links, and read information outlined below.

[Heat Release Manual](#)

[Air Intake Manual](#)

### HEAT RELEASES

The **heat release opening is required for all fireplaces** and allows warm air to passively flow back into the room. This controls the temperature of the surrounding walls, keeping them relatively cool, and allowing a TV or art piece to hang 12" from the glass opening regardless of fireplace size, style, or safety barrier.

#### **Heat Release Keys:**

1. Must remain open at all times.
2. Must be at the top of the enclosure and within 1" – 3" of the non-combustible firestop.
3. Can be located on any interior side of the surround
4. If placed on the side of the surround it must be on both sides and sized equally
5. The heat release must be interior facing
6. The heat release may be oriented horizontally or \*vertically.  
\* Vertically oriented heat releases must be 30% larger than horizontally oriented heat releases and must be kept 3" below the firestop and 24" above the top of the fireplace.
7. Restriction created by finishing over opening must be considered when calculating open-air flow
8. All sizing is assuming the surround stops a minimum of 40" above the fireplace

Fireplaces sized **30" – 50"** the vent area must be at least **100 square inches of open-air flow.**  
(\*130 square inches of open-air flow if vertically oriented)

Fireplaces sized **60" – 70"** the vent area must be at least **140 square inches of open-air flow.**  
(\*182 square inches of open-air flow if vertically oriented)

Fireplaces sized **80" – 100"** the vent area must be at least **200 square inches of open-air flow.**  
(\*260 square inches of open-air flow if vertically oriented)

## NOTICE

Any opening greater than the minimum size is highly recommended and will help reduce the temperature of the surrounding walls. Make sure a non-combustible fire stop is placed atop the inside of the chase and is framed in a way that does not allow any pockets of heat to be formed. All heat should be able to rise to the fire stop and freely flow out of the heat release opening into the room.

# FLARE FIREPLACES

---

## HEAT RELEASE EXAMPLES

---

### DROP WALL

The drop-wall heat release is implemented by creating a surround that reaches the minimum ceiling level of 40" above the top of the fireplace, and instead of bringing the surround all the way to the ceiling you hold your entire surround from the ceiling, opening the top of the surround to allow heat to rise out of the top and into the room.



---

### SHADOW LINE

The shadow line heat release is implemented by dropping your surround 1" – 3", recessing your build back 3" – 4" then finishing to the ceiling. This will create a small L-shaped reveal at ceiling level where the portion of the reveal running parallel to the ceiling is left open across the length and/or sides of the surround.

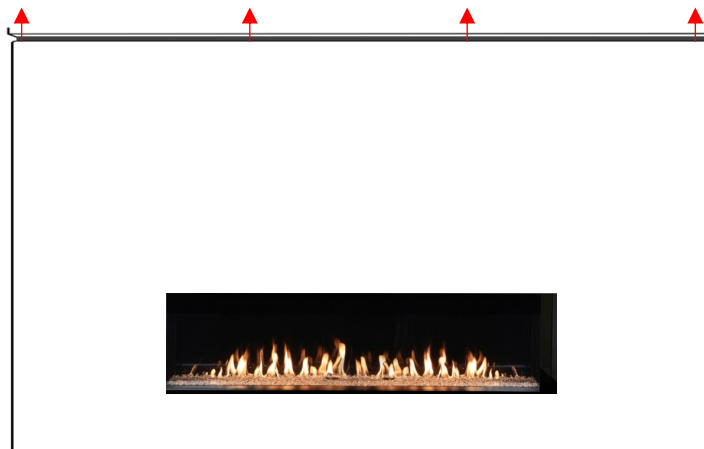

# FLARE

## FIREPLACES

---

### LINEAR SLOT OR LOUVERED GRATE

The linear slot or louvered grate heat release is implemented by creating an opening in your fireplace surround within 1" – 3" of the non-combustible firestop which meets the open air-flow requirements and allows the heat to enter the room through the opening provided.

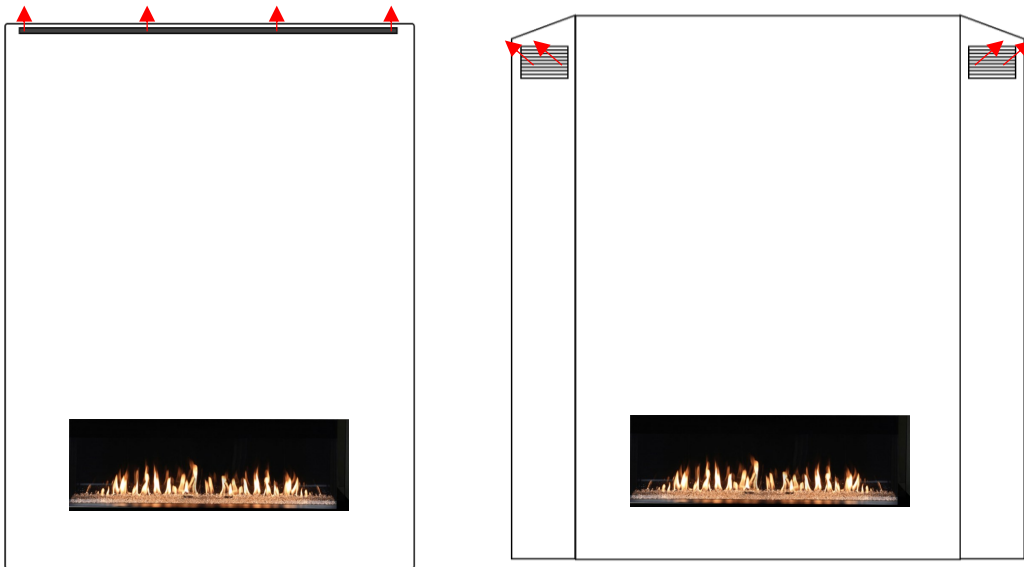

# FLARE

## FIREPLACES

---

### AIR INTAKE

The air intake opening is required for all fireplaces equipped with the upgraded double/triple glass safety barrier. The air intake allows for fresh air from a conditioned space to cool the outer glass safety barrier, preventing it from reaching temperatures that require a screen. This also contributes to the temperature of the surrounding walls, so its implementation is key to a safe and long-lasting fireplace.

#### Air Intake Keys:

1. Must remain open at all times.
2. Must be at the bottom of the enclosure and begin within 2" – 4" off the floor.  
*Notes: The available height off the floor may increase or decrease based on the use of telescopic legs or implementation of a platform.*
3. Can be located on any interior side of the surround
4. If placed on the side of the surround it must be on both sides and sized equally
5. The air intake must be interior facing
6. The air intake must be horizontally oriented.
7. Restriction created by finishing over opening must be considered when calculating open-air flow
8. May pull room-temp air from a space below the fireplace, like an attic or conditioned crawl space

Fireplaces sized **30" - 50"** - vent area must be at least **50 square inches of open-air flow**.

*\*See-Through and Room Definer 30" – 50" vent area must be at least 100 square inches of open-air flow.*

Fireplaces sized **60" - 70"** - vent area must be at least **70 square inches of open-air flow**.

*\*See-Through and Room Definer 60" – 70" vent area must be at least 140 square inches of open-air flow.*

Fireplaces sized **80" - 100"** - vent area must be at least **100 square inches of open-air flow**.

*\*See-Through and Room Definer 80" – 100" vent area must be at least 200 square inches of open-air flow.*

## NOTICE

Any opening greater than the minimum size is highly recommended and will help reduce the temperature of the glass and surrounding walls. Make sure if building a platform to raise the fireplace, the platform is completely open to allow fresh air to flow to the underside of the fireplace. All room temperature air should be able to easily reach the underside of the fireplace. *\*See-Through and Room Definer fireplaces must have their air intake doubled, and preferably balanced on both long sides of the unit to feed the double glass fans evenly.*

# FLARE FIREPLACES

---

## DOUBLE GLASS REQUIRED AIR INTAKE EXAMPLES

---

### FLOATING HEARTH

The floating hearth intake uses the depth of an existing hearth to mask an opening tucked underneath. This masking allows you to create an opening that is both large enough to exceed the minimum sizing requirements and allow a technician a large space for accessing the components.



# FLARE FIREPLACES

---

## TOE-KICK REVEAL

To implement a toe-kick reveal, construct your build so that it stops 2" – 4" above the floor and is recessed 2" – 3" from the front edge. Then, extend the finishing to the floor. This creates an upside-down L-shape, where the segment of the L parallel to the floor remains open along the entire length. This design allows you to also remove the portion of the build that sits perpendicular to the floor, opening up large access to the fireplace components.





# FLARE FIREPLACES

---

## LEFT AND RIGHT-SIDE VENTS

Vents may be cut into the finishing material or placed over an opening in the surround to finish out the air intake. It's critical that if putting an air intake on the side of your surround it's on both sides and sized evenly to allow enough fresh air to reach the fireplace in a balanced manner.

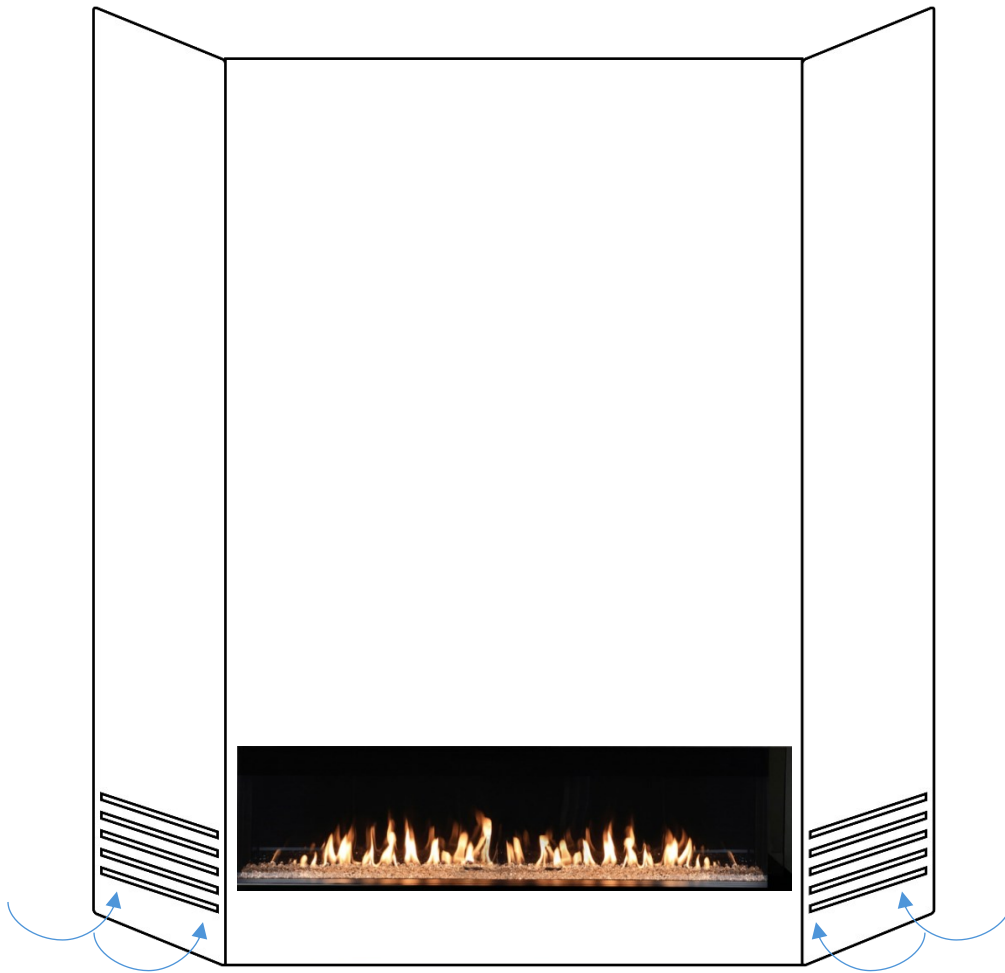

## NOTICE

Fireplaces Sized 70"-100" may require openings to either be larger to feed the center of your fireplace, or an opening also placed across the front to prevent the fans found at the center of your fireplace from being starved of fresh air, creating hot spots on your glass.

# FLARE FIREPLACES

---

## LINEAR SLOT

The linear slot is an effective and straightforward method for implementing an air intake. Simply cut a slot in the face or backside of the fireplace surround to meet the necessary airflow requirements. If you are adding a custom finishing piece, consider any restrictions this piece creates, and ensure it does not obstruct the opening and maintains proper airflow.

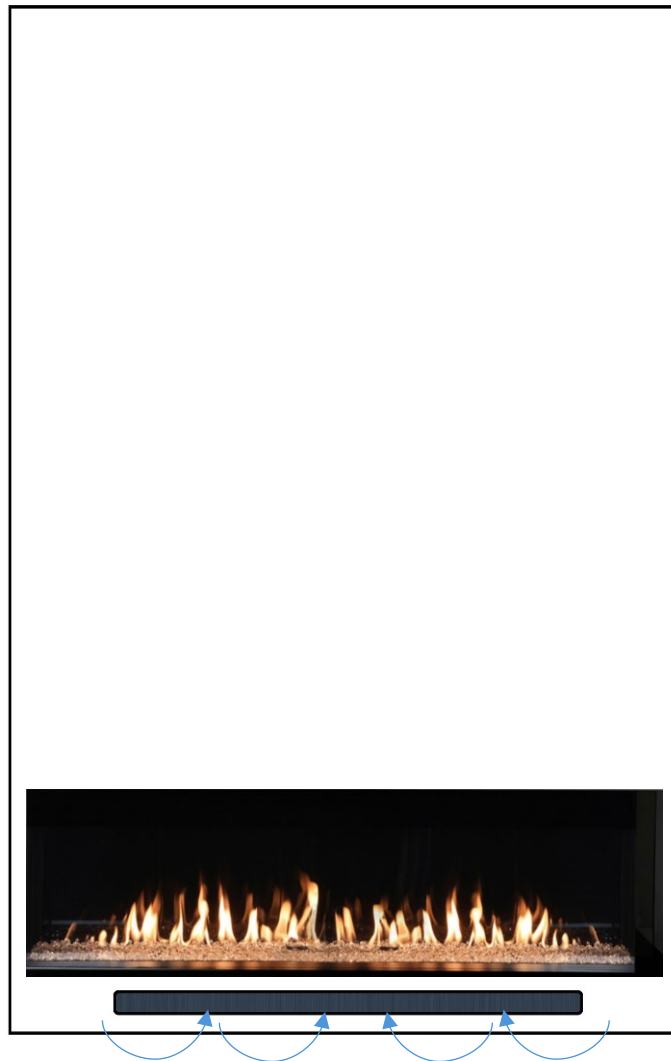

# FLARE FIREPLACES

## FLARE FRONT, SEE THROUGH, AND CORNER FIREPLACE CLEARANCE

### FLAT – SIDE AND ISOMETRIC VIEW & CLEARANCES

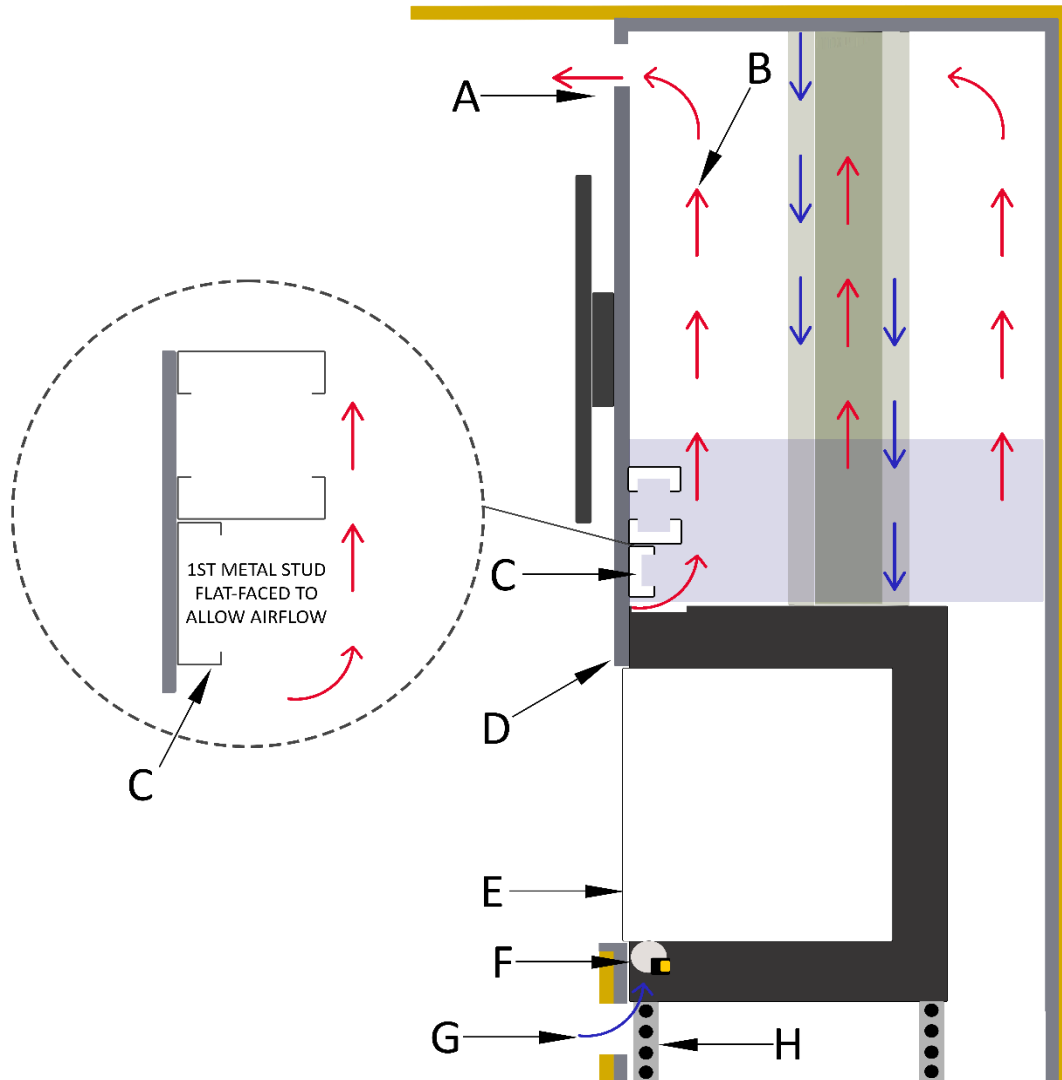

**Warning!** – Maintain open Air flow between the fireplace and drywall. Make sure cables or any other materials are not blocking.

# FLARE

## FIREPLACES

---

- A. Top Vent system - Hot Airflow outlet from the wall enclosure **MUST** remain open. The outlet must be at the top part of the enclosure, but not necessarily at the front, if the measurements below are maintained.

Fireplaces sized **30" – 50"** the vent area must be at least **100 square inches of open-air flow.**

(\*130 square inches of open-air flow if vertically oriented)

Fireplaces sized **60" – 70"** the vent area must be at least **140 square inches of open-air flow.**

(\*182 square inches of open-air flow if vertically oriented)

Fireplaces sized **80" – 100"** the vent area must be at least **200 square inches of open-air flow.**

(\*260 square inches of open-air flow if vertically oriented)

- B. Open air flow for hot air to rise from the fireplace to the top of the enclosure. The enclosure can be supported by studs, but open-air flow **MUST** always be maintained. In case needed, insulation for electric wires or systems may be added but it is **important** to keep most of the air flow open. **Never place any insulation on the fireplace.**
- C. Metal Stud below non-combustible material line. Below the non-combustible line, all studs used should be metal type. No studs to be connected to the fireplace frame (1/2 Inch clearance). Open hot airflow **MUST** be maintained and should not be blocked. **Note: Max recess of TV cavity should not exceed 6". Recesses exceeding this dimension run the risk of creating a shelf and hindering air flow above unit, resulting in a wall that may overheat.**
- D. Non-combustible material is placed flat on the front fireplace support bracket. The support bracket holds the fire-rated, non-combustible, material and allows hot air to rise from the glass into the fireplace enclosure. Hot air is to be released into the room using the top static vent opening.
- The fireplace enclosure must allow air to rise and circulate from the top of the fireplace glass (from lower vent opening), to be released back to the room from the top.
  - To increase heating, the enclosure should prevent hot air from being released to the attic by venting it back to the room using the static vent system (A).
  - Non-combustible stud **MUST NOT** be connected or drilled into the fireplace frame. Drilling into the fireplace frame can result in damage to the fireplace.
- E. Cold air, drafted from the room through the lower static vent, (G) flows up and is heated by the fireplace. The Cold air gap should remain open to allow air to flow up and exchange heat with the fireplace. The fireplace can be installed with double glazing glass system or safety screens. A blower system may be used to push cold air up (F).

# FLARE

## FIREPLACES

---

F. Heat exchange blowers are optional when a fireplace is installed with safety screens. Heat exchange blowers must be included when installing a double glass fireplace. The blowers are designed to move cold air from the room using the lower vent opening (G) up against the fireplace glass. As the air flows on the glass, it is heated and released back to the room from the glass front and from the top (A) vent opening.

G. Lower vent opening. **OPTIONAL** for normal installation. A **MUST** for double glass installation or blower kit option.

For fireplaces sized **80" & 100"** – vent area must be at least **100 square inches OPEN AIR FLOW**.

For fireplaces sized **60" & 70"** - vent area must be at least **70 square inches OPEN AIR FLOW**.

For fireplaces sized **50"** and below - vent area must be at least **50 square inches OPEN AIR FLOW**.

**WARNING!** See Through and Room Definer fireplaces the air intake requirements are double, equal on both sides.

H. Adjustable fireplace legs.

# FLARE FIREPLACES

## L SHAPE – SIDE AND ISOMETRIC VIEW

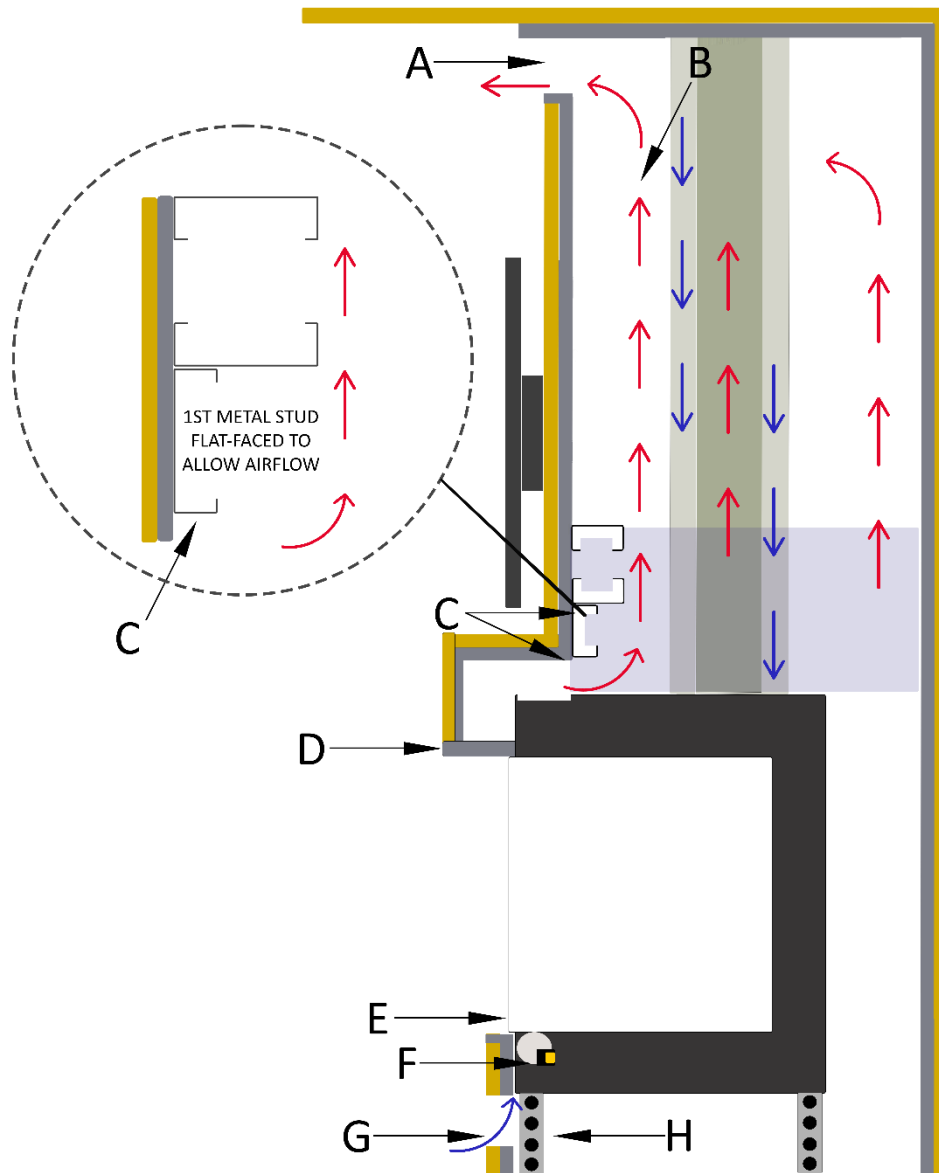

**Warning!** – Maintain open Air flow between the fireplace and drywall. Make sure cables or any other materials are not blocking.

# FLARE

## FIREPLACES

---

- A. Top Vent system - Hot Airflow outlet from the wall enclosure **MUST** remain open. The outlet must be at the top part of the enclosure, but not necessarily at the front, if the measurements below are maintained.

Fireplaces sized **30" – 50"** the vent area must be at least **100 square inches of open-air flow.**

(\*130 square inches of open-air flow if vertically oriented)

Fireplaces sized **60" – 70"** the vent area must be at least **140 square inches of open-air flow.**

(\*182 square inches of open-air flow if vertically oriented)

Fireplaces sized **80" – 100"** the vent area must be at least **200 square inches of open-air flow.**

(\*260 square inches of open-air flow if vertically oriented)

- B. Open air flow for hot air to rise from the fireplace to the top of the enclosure. The enclosure can be supported by studs, but open-air flow **MUST** always be maintained. In case needed, insulation for electric wires or systems may be added but it is **important** to keep most of the air flow open. **Never place any insulation on the fireplace.**
- C. Metal Stud below non-combustible material line. Below the non-combustible line, all studs used should be metal type. No studs to be connected to the fireplace frame (1/2 Inch clearance). Open hot airflow **MUST** be maintained and should not be blocked. **Note: Max recess of TV cavity should not exceed 6". Recesses exceeding this dimension run the risk of creating a shelf and hindering air flow above unit, resulting in a wall that may overheat.**
- D. Non-combustible material is placed flat on the front fireplace support bracket. The support bracket holds the fire-rated, non-combustible, material and allows hot air to rise from the glass into the fireplace enclosure. Hot air is to be released into the room using the top static vent opening.
- The fireplace enclosure must allow air to rise and circulate from the top of the fireplace glass (from lower vent opening), to be released back to the room from the top.
  - To increase heating, the enclosure should prevent hot air from being released to the attic by venting it back to the room using the static vent system (A).
  - Non-combustible stud **MUST NOT** be connected or drilled into the fireplace frame. Drilling into the fireplace frame can result in damage to the fireplace.
- E. Cold air, drafted from the room through the lower static vent, (G) flows up and is heated by the fireplace. The Cold air gap should remain open to allow air to flow up and exchange heat with the fireplace. The fireplace can be installed with double glazing glass system or safety screens. A blower system may be used to push cold air up (F).

# FLARE

## FIREPLACES

---

F. Heat exchange blowers are optional when a fireplace is installed with safety screens. Heat exchange blowers must be included when installing a double glass fireplace. The blowers are designed to move cold air from the room using the lower vent opening (G) up against the fireplace glass. As the air flows on the glass, it is heated and released back to the room from the glass front and from the top (A) vent opening.

G. Lower vent opening. **OPTIONAL** for normal installation. A **MUST** for double glass installation or blower kit option.

For fireplaces sized **80" & 100"** – vent area must be at least **100 square inches OPEN AIR FLOW**.

For fireplaces sized **60" & 70"** - vent area must be at least **70 square inches OPEN AIR FLOW**.

For fireplaces sized **50"** and below - vent area must be at least **50 square inches OPEN AIR FLOW**.

**WARNING!** See Through and Room Definer fireplaces the air intake requirements are double, equal on both sides.

H. Adjustable fireplace legs.



# FLARE

## FIREPLACES

### SIDE OVERHANG SPECIFICATION FOR LEFT, RIGHT, AND DOUBLE CORNER FIREPLACES

When installing a Left, Right, or Double Corner fireplace with left and right non-combustible overhangs, please follow the specification outlined below to maintain a safely operating fireplace and surround.

- First 18" of framing above the fireplace must be metal studs.
- All finishing materials within and above this glass recess must be non-combustible
- At no point can your overhang reach down into the viewing area.
- There is no maximum distance for overhangs on the left or right side of the fireplace.
- Minimum distance to a non-combustible is 12" from the glass
- Minimum distance to a combustible is 36" from the glass

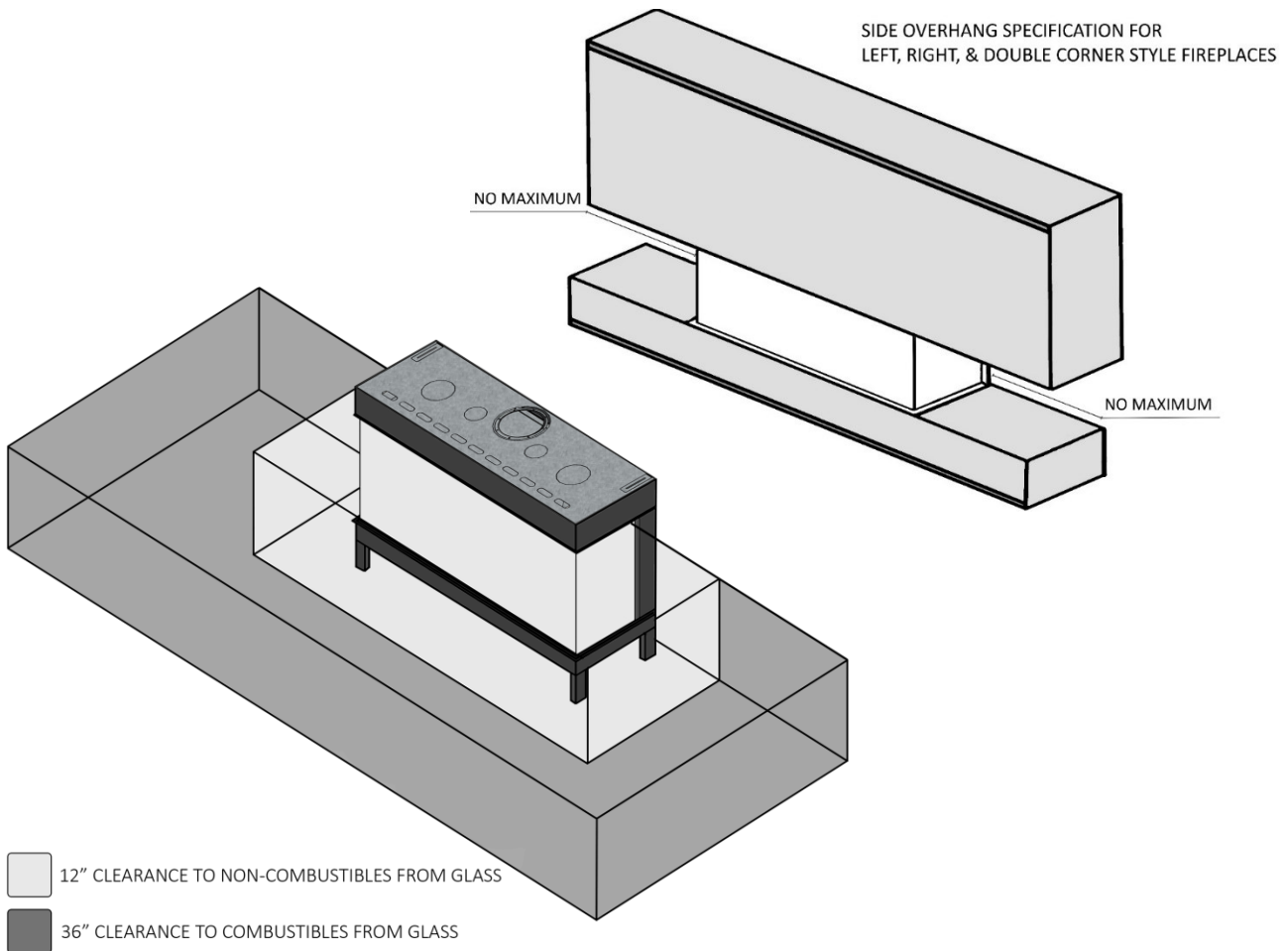

# FLARE

## FIREPLACES

### INDOOR/ OUTDOOR KIT

The following installation information is used for the Flare Fireplace outdoor kit. The outdoor window kit can only be used with Flare Front, Flare See Through, and the Flare See Through Passage fireplaces. The Flare outdoor kit is installed like a window and must be weatherproofed on all sides. It must include an overhang or cover to protect the face from exterior elements. All fireplace clearances must be followed when installing a Flare Fireplace next to this outdoor window kit. Appliance location

### OUTDOOR KIT INSTALLATION CONSIDERATIONS

Because the outdoor kit only adds weather resistance to the face of an interior fireplace, a weatherproof enclosure is required for the unit and its components. It will also need the openings for your heat release, and if using double glass, air intakes to face the interior of the build, and only install these units with the proper overhang or roof considerations. This will help with the long-term protection of your fireplace and its components.

**Below are other examples of elements to consider for your outdoor kit equipped fireplace.**

- The fireplace must be installed in a completely weatherproof enclosure, with one interior facing the wall.
- The outdoor kits are made from a high-quality black painted stainless steel and are weather resistant on the front window only.
- All fireplace controls and gas components must be installed in a weatherproof enclosure.
- The outdoor kit can occasionally tolerate small amounts of water but is not waterproof.
- The fireplace must be enclosed in a weatherproof enclosure covered in typical weatherproof material, such as siding/ stucco/stone/tile, etc. and have a weatherproof structure to shed water that extends horizontally beyond the front and side perimeter of the fireplace.
- Water running down vertical surfaces should be directed away from the fireplace using flashing. Measures must be taken to ensure any accumulated water drains away from the fireplace and structure.
- When the fireplace is installed on surfaces where water may collect or cause damage, a suitable drainage pan should be placed under the unit and the water drained away.
- Do not use the remote-controlled handset supplied with the appliance. The use of the thermostat on the remote may result in continued operation of the fireplace.
- Exposure to outdoor sun - Exposure to outdoor sunlight will cause some painted finishes to fade over time. Fading is unavoidable and not covered under warranty. Minimize fading by installing the fireplace away from direct sunlight.
- Make sure the fireplace is fully turned off when attempting to clean the front of the fireplace (including pilot).

# FLARE FIREPLACES

## OUTDOOR KIT OVERHANG REQUIREMENTS

A weatherproof overhang in front of the fireplace is  $\frac{1}{2}$  the height of the fireplace face-wall, measured from the base of the unit to the ceiling.

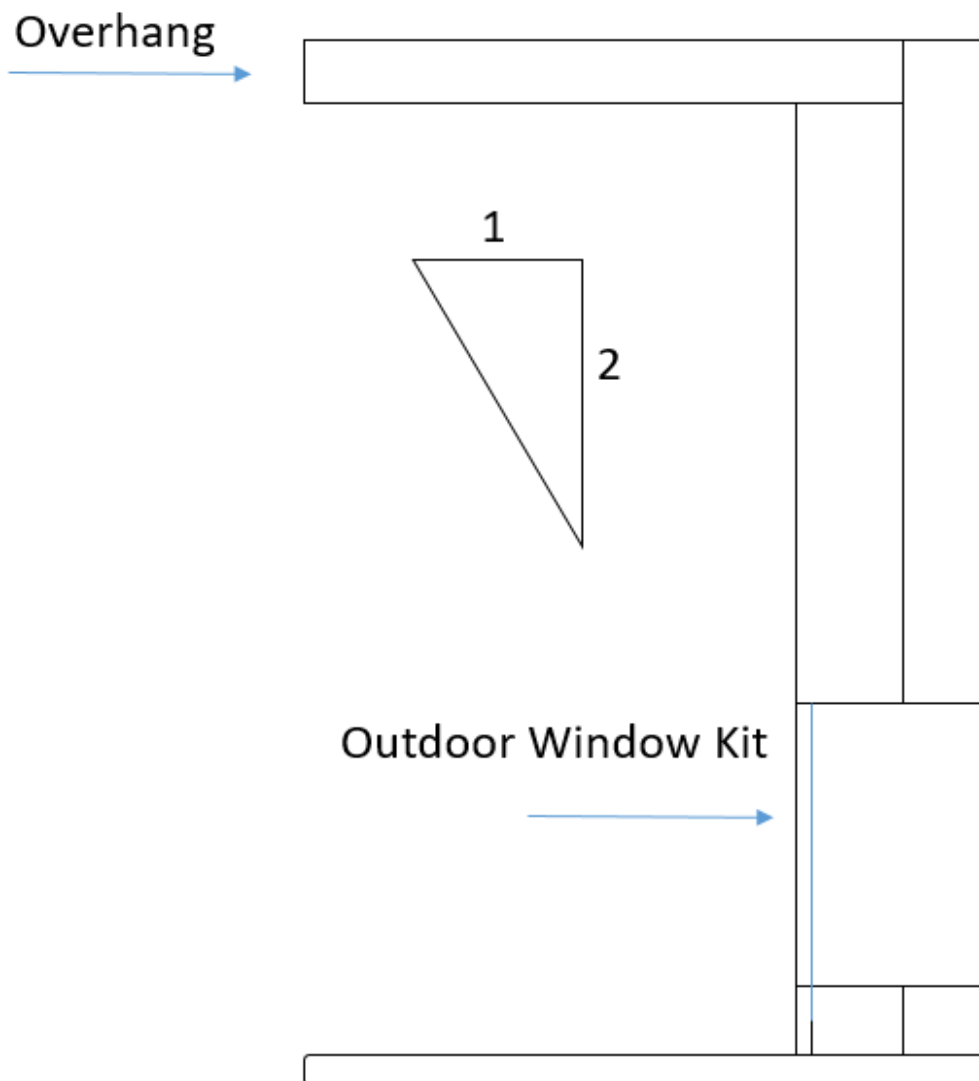

# FLARE FIREPLACES

## OUTDOOR KIT FRAMING AND FINISH

All studs and surrounding material should follow the fireplace clearances and non-combustible requirements

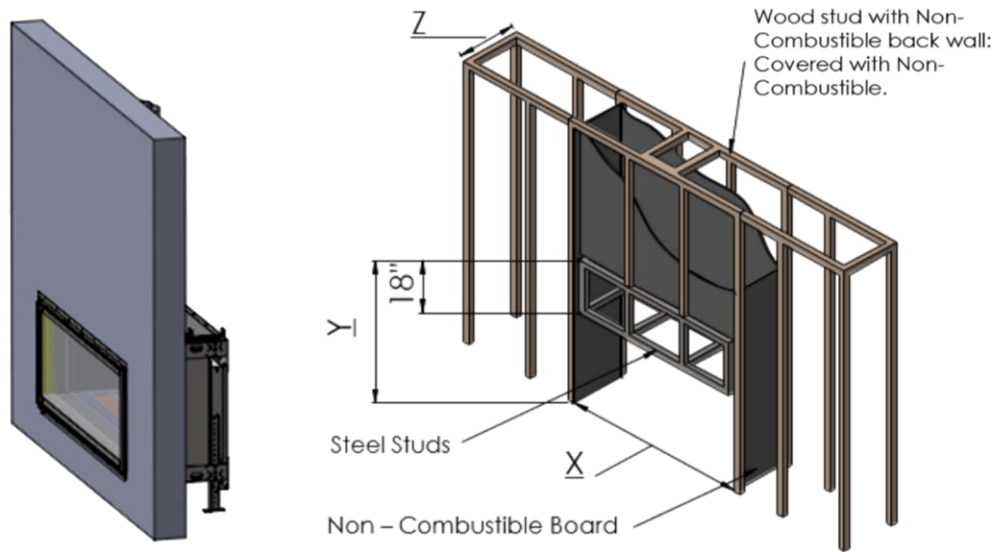

## OUTDOOR KIT CLEARANCE TO NON-COMBUSTIBLE WALL

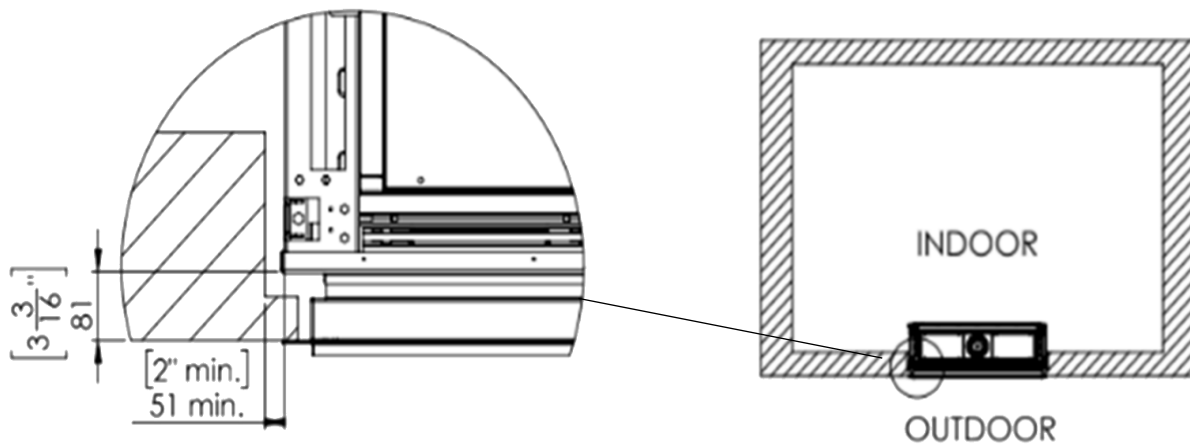

# FLARE

## FIREPLACES

### OUTDOOR KIT OPENING DIMENSIONS

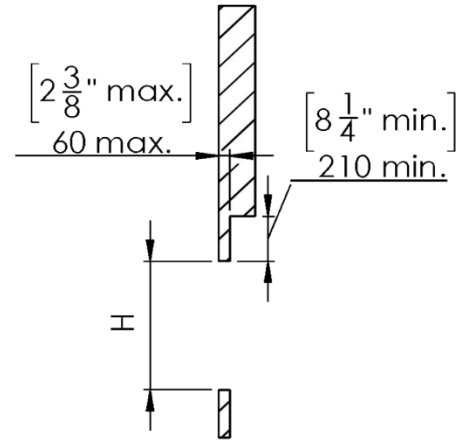
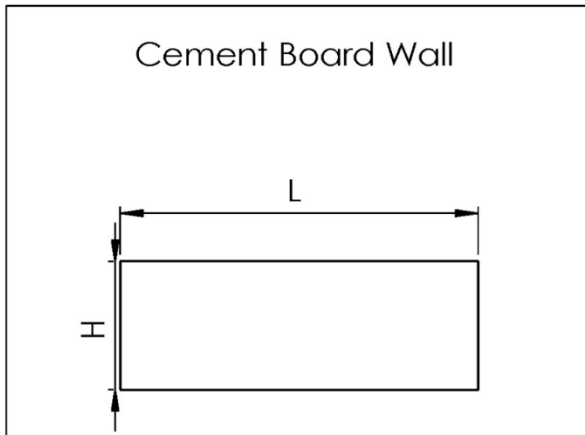

External Opening Dimensions			
		H	L
45	Inch	20	43 <sup>13</sup> / <sub>16</sub>
	mm	508	1113
50	Inch	20	50 <sup>8</sup> / <sub>16</sub>
	mm	508	1283
60	Inch	20	60 <sup>5</sup> / <sub>16</sub>
	mm	508	1783
70	Inch	20	70 <sup>3</sup> / <sub>16</sub>
	mm	508	1783
80	Inch	20	82 <sup>12</sup> / <sub>16</sub>
	mm	508	2102
100	Inch	20	99 <sup>11</sup> / <sub>16</sub>
	mm	508	2532

Use the Flare architectural guide for information on the window size and opening:  
<http://flarefireplaces.com/portfolio-items/flare-outdoor/>

# FLARE

## FIREPLACES

### WEATHER-PROOF YOUR OUTDOOR KIT CAVITY

The outdoor window kit should be sealed with non-combustible tape, around the inner most flange, prior to covering it with brick or stucco. All non-combustible finishing material can come directly to the outer-most flange around the face of the fireplace. Creating that frameless appearance around your opening.



### FIREPLACE BURNER DIMENSIONS

BURNER TYPE	SIZE (in)	FIREPLACE SIZE	# OF BURNERS
A	21 11/16"	30"	1
B	31 12/16"	45"	1
C	40 1/16"	50"	1
D	50 1/16" (14", 22", 14")	60"	3
E	59 15/16" (14", 32", 14")	70"	3
F	68 4/16" (14", 40", 14")	80"	3
G	84" (22", 40", 22")	100"	3

# FLARE FIREPLACES

## HOME AUTOMATION

A Flare Fireplace can be operated through an external source (See cautionary remark below) such as a smart home (home automation) system by using the 6- pin connector on the SIT receiver **X8 port** in place of the included Wall Switch. The existing Flare Fireplace wall switch cable must be used to connect the receiver to the home automation system. The existing Flare Fireplace wall switch cable can be located by removing the included Flare Fireplaces wall switch, exposing the wire provided, and replacing it with a dry contact On/Off relay controlled by the home automation system. The existing Flare Fireplace wall switch cable can be extended up to 100 FT for integration into a new or existing Home Automation System. **Please contact Flare Support for additional information on appropriate relays to be used.**

1. The included Flare Fireplaces Wall Switch Can be seen in the example below

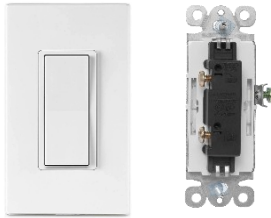

2. An example of the exposed wall switch with cables used to connect to dry contact On/Off relay can be seen below.

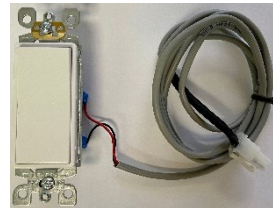

3. Remove the physical switch exposing your wires as seen below



4. Use exposed cables to connect your system to dry contact On/Off relay and tie into home automation or smart product.

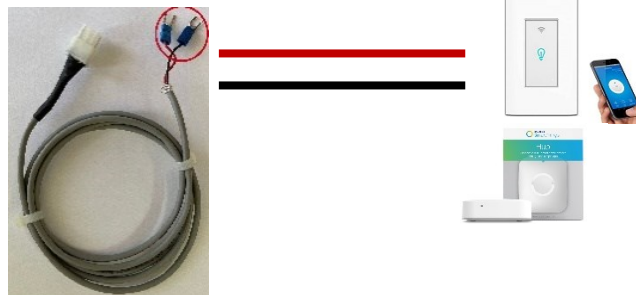

## WARNING!

Do not control fireplace from outside of home using externally connected device. Only operate 3<sup>rd</sup> party application or home automation when you can physically see the fireplace turning on & off. It is not meant to operate without line of sight to fireplace.

# FLARE FIREPLACES

## ELECTRIC AND CONTROL

### ELECTRIC DIAGRAM - SCREEN

**X8:** Wall Switch / Home Automation

**X4:** Closed Circuit (Jumper Present)

**X3 and X2:** Spark Ignitor and Sensor

**X1:** Power (Green : Ground, White : Common, Black : Line)

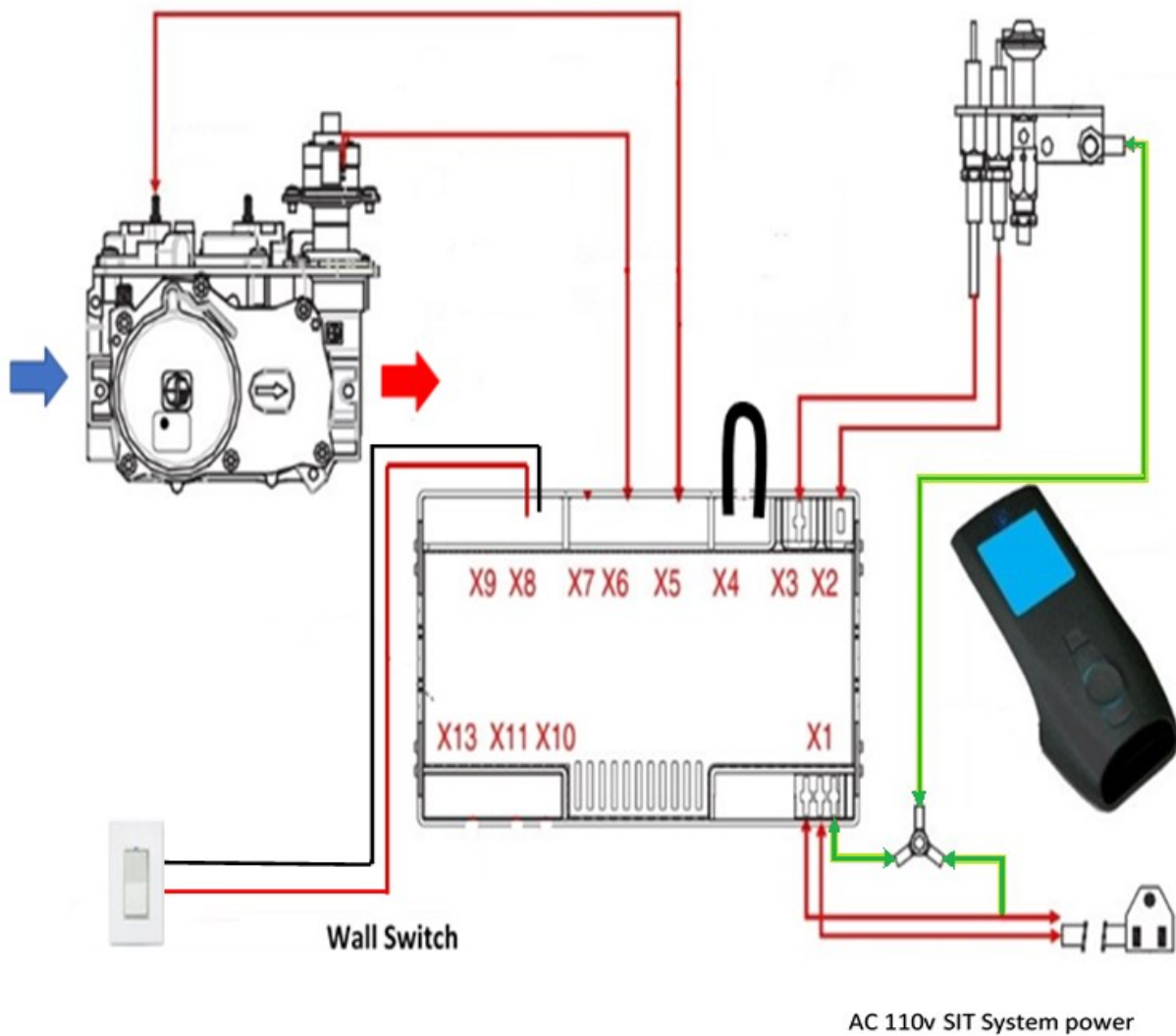



# FLARE

## FIREPLACES

### SIT PROFLAME II DIAGRAM – DOUBLE GLASS AND POWER VENT

**X13:** Auxiliary used to open and close relay port on double glass board

**X8:** Wall Switch / Home Automation

**X4:** On/Off, controlled via Flare Control Board verification

**X3 and X2:** Spark Ignitor and Sensor

**X1:** Power (Green : Ground, White : Common, Black : Line)

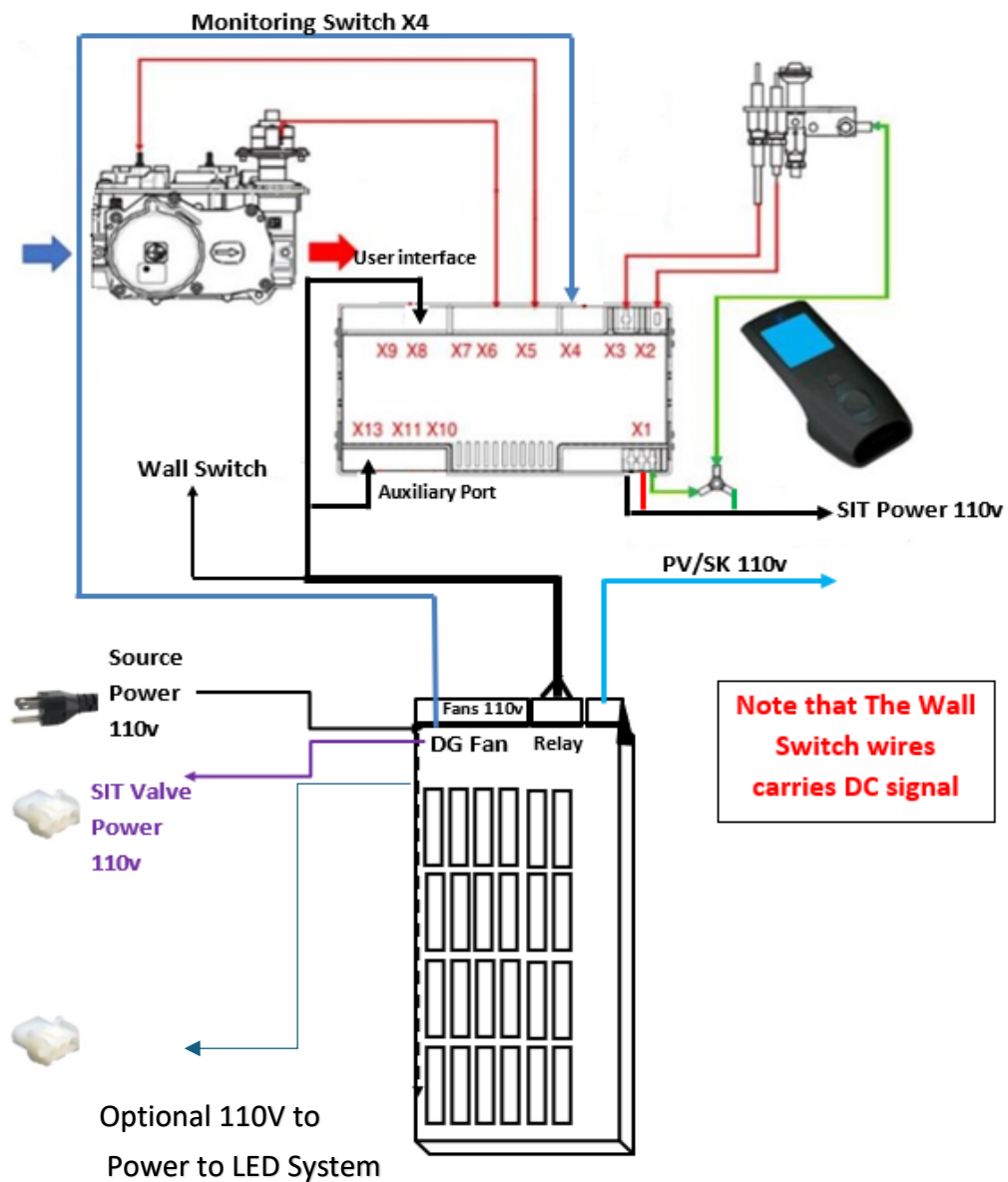

# FLARE

## FIREPLACES

### DOUBLE GLASS BOARD & LED LIGHT GUIDE

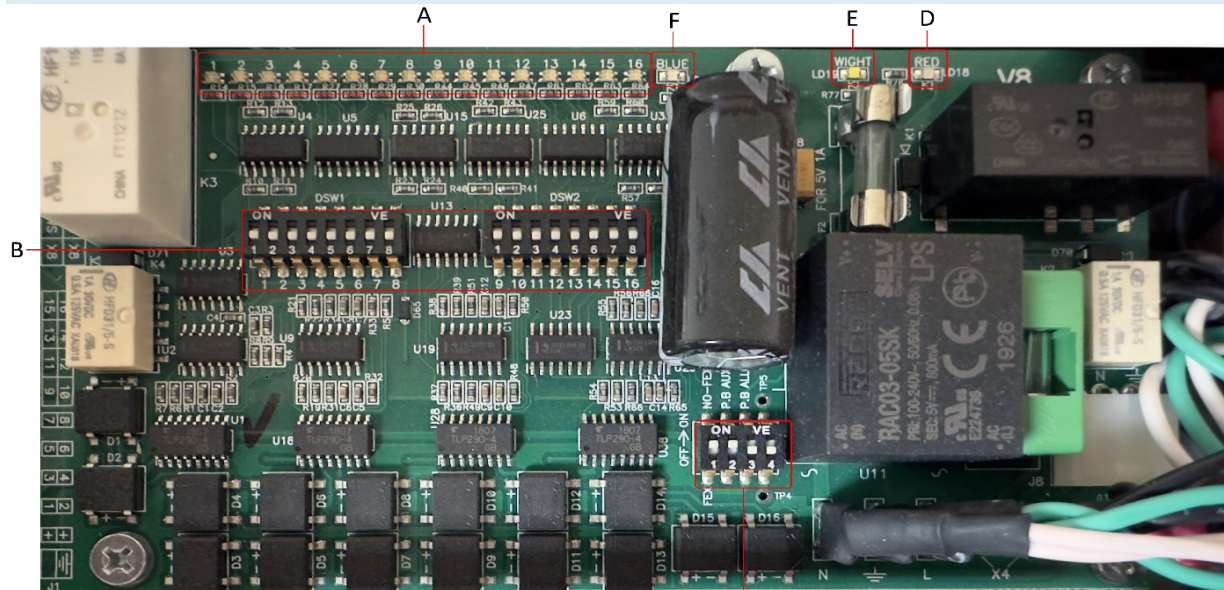

- A. **Double Glass Fan LEDs:** When fans are operating properly these LEDs will be green for each fan being monitored on the fireplace. When fans are failing to operate properly the LEDs will be amber.
- B. **Double Glass Fans Monitoring Dip-Switches:** These dip-switches will be off when monitoring double glass fans, and on when either a fan is not present or being bypassed for troubleshooting.
- C. **Fan Exhaust Monitoring Dip-Switches:**
  1. **Power Vent Dip-Switch:** This switch will be off when a power vent is connected to the system, and on when a power vent is not present or being bypassed for troubleshooting.
  2. **Relay Dip-Switch:** This switch will be off when a fireplace is equipped with either double glass or a power vent, and on only when bypassed for troubleshooting.
  3. **Master Bypass Dip-Switch:** This will always be off unless being turned on to bypass for troubleshooting.
  4. N/A
- D. **Red Power LED:** This light will be on when the control board is getting 110V power, and only turns off when power is disconnected.
- E. **White Relay LED:** This light will be turned on when the units ignition process begins and a request for the double glass or power vent fans be turned on is made successfully.
- F. **Blue Power Vent LED:** The blue power vent LED only turns on when the power vent is properly powered and communicating with control board.

# FLARE FIREPLACES

## ELECTRICAL DIAGRAM - POWER VENT SYSTEM

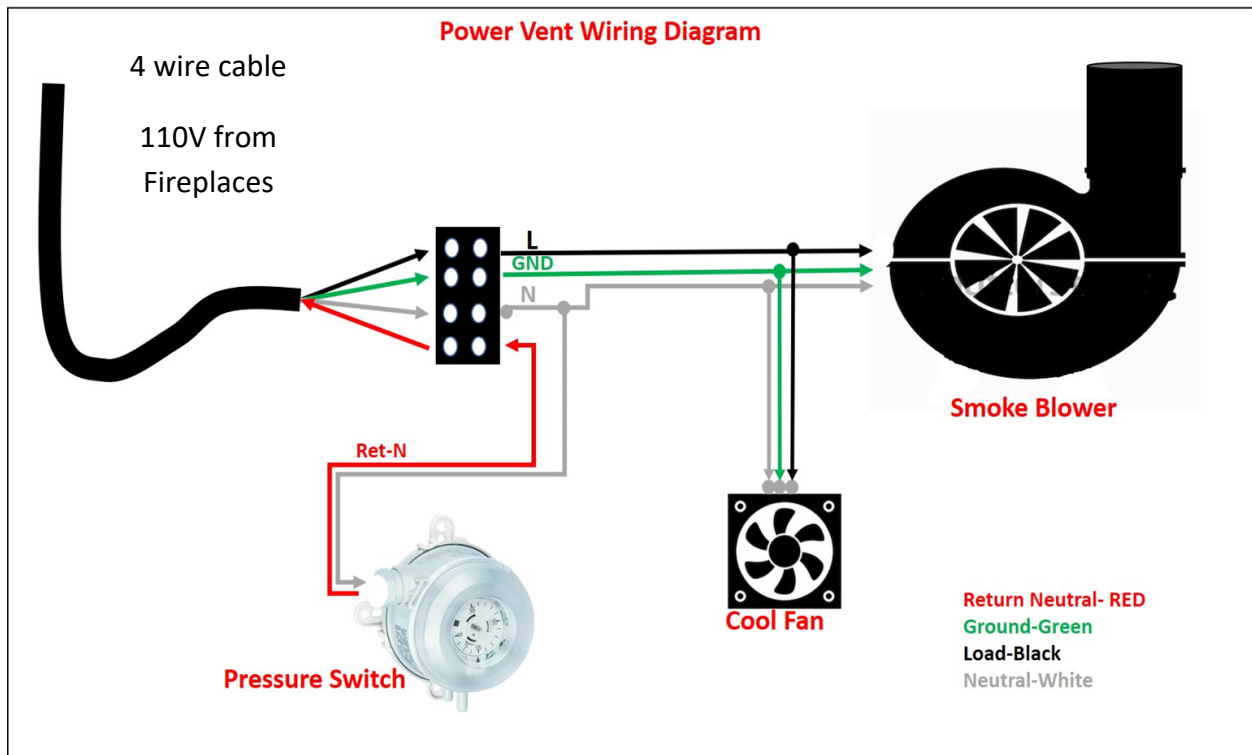

# FLARE

## FIREPLACES

### REPLACEMENT PARTS

See below for SIT ProFlame II replacement parts list. These are the most commonly used components a technician may need when working on the fireplace system.

- Please contact your local fireplace dealer to purchase replacement parts.
- Please provide description, part number, Part SKU, and Fireplace serial number.
- Please use a trained and certified technician for any fireplace related service.

PART NAME	DESCRIPTION	SKU
SIT-Full Gas System	Gas Valve System, Receiver, SIT Wiring	<a href="#">1SITCGS</a>
SIT-Valve NG	Natural Gas Valve for SIT System	<a href="#">1SITGVNG</a>
SIT-Valve LP	Liquid Propane Gas Valve for SIT System	<a href="#">1SITGVLP</a>
SIT-Remote	Remote for SIT System	<a href="#">1SITREM</a>
SIT-Receiver	Receiver for SIT System	<a href="#">1SITREC</a>
SIT-Wall Switch X-8	Wall Switch for Screened SIT System	<a href="#">1SITWS</a>
SIT-Data X-5 Cable	Data Cable for SIT System	<a href="#">1SITX5DC</a>
SIT- Ground Cable	Ground Cable for SIT System	<a href="#">1SITGC</a>
SIT-LED Control	Cable to control LED Lights with SIT Module	<a href="#">1SITRGBC</a>
SIT-V4 Control Board	Main Control Board for SIT V4 System	<a href="#">1SITCBV4</a>
SIT-V5 Control Board	Main Control Board for SIT V5 System	<a href="#">1SITCBV5</a>
SIT-110 X-1 Cable With Molex	SIT Double Glass Wiring Harness with Molex	<a href="#">1SITX1-M</a>
SIT- 110 X-1 Cable	SIT Screen Adapter Wiring Harness	<a href="#">1SITX1</a>
SIT-Pilot Assembly NG	Natural Gas Pilot assembly for SIT System	<a href="#">1SITPANG</a>
SIT-Pilot Assembly LP	Liquid Propane Pilot Assembly for SIT System	<a href="#">1SITPALP</a>
SIT - Pilot Orifice NG	Natural Gas Pilot Orifice	<a href="#">STPORNG</a>
SIT- Pilot Orifice LP	Liquid Propane Pilot Orifice	<a href="#">STPORLP</a>
SIT-Spark Cable	Ignition Cable for SIT System	<a href="#">1SITSC</a>
SIT - Thermocouple	Brass Thermocouple Fitting for GV60 Valve	<a href="#">1SITPTH</a>
SIT - Pilot Gas Line	Metal Pilot Tube	<a href="#">1SITPPT</a>
SIT-NG Motor	Natural Gas Motor for SIT Gas Valve	<a href="#">1SITNGMT</a>
SIT-LP Motor	Liquid Propane Motor for SIT Gas Valve	<a href="#">1SITLPMT</a>
SIT-Jumper x-4	Relay Jumper for SIT System	<a href="#">1SITJUMP</a>
SIT-V5-V4	SIT V5 - V4 Fan Cable	<a href="#">1SITV5V4FAN</a>
SIT-V4 DG Relay Kit and Wall Switch	Double Glass Relay Kit and Wall Switch for V4	<a href="#">1SITDGRL4</a>
SIT-V5 DG Relay Kit and Wall Switch	Double Glass Relay Kit and Wall Switch for V5	<a href="#">1SITDGRL5</a>
SIT Pilot Brass Compression Fitting	Brass Pilot Compression Fitting for SIT System	<a href="#">1SITBRASS</a>
SIT Technicians Toolbox	Most Common Replacement Parts For The SIT	<a href="#">SITTOOLBOX</a>

## MAINTENANCE

### WARNING!

- It's recommended that a qualified service technician perform a routine inspection at the beginning of each heating season.
- Disconnect power before attempting maintenance or repair of the fireplace.
- Installation and maintenance must be performed by an authorized qualified installer, service agency or gas supplier.
- Any safety screen or guard removed for servicing must be placed back before operating this appliance.
- Do not use this appliance if any part has been under water. Immediately call a qualified service technician to inspect the unit and to replace any part of the control system and any gas valve that has been under water or impacted.
- Any alteration to the product that causes soot or carbon to form and results in damage is not the responsibility of the manufacturer.
- Do not modify or substitute any part of this appliance.
- Inspect the external vent cap on a regular basis to make sure that no debris, plants, trees, or shrubs are interfering with the air flow.
- Do not operate the fireplace without the fireplace glass.
- It is imperative that control compartments, screens, or fans system for double glass be kept clean and free of obstructions. These areas provide the air necessary for safe operation.
- To light the heater using the built-in igniter, do not use matches or any other external device.
- Never remove, replace, modify, or substitute any part of the heater unless instructions are given in this manual. A trained technician must do all the other work. Do not modify or replace orifices.
- Fireplaces in commercial applications are used more frequently and may require more frequent maintenance.

# FLARE

## FIREPLACES

---

- Failure to inspect and maintain the fireplace may lead to improper combustion and a potentially dangerous situation. We recommend the following procedures be done by a qualified technician.

### GLASS MAINTENANCE

- Always use suction cups to remove the fireplace glass.
- Use the manual procedure for instruction on how to remove the fireplace glass.
- Always use gloves when removing the glass to protect your hand and prevent fingerprints on the glass.
- Do not use abrasive cleaners on the glass panels.
- Do not attempt to clean the glass panels when they are hot.
- Do not use normal household (usually ammonia-based) glass cleaners to clean the glass as these cleaners can leave a permanent stain. Only a gas fireplace glass cleaner should be used.
- Verify no cracks or breakage in the glass.
- Place glass in a safe location to prevent breakage.
- Never attempt to operate the fireplace without the fireplace glass.

### PILOT MAINTENANCE

- Visually inspect the pilot flame. The pilot flame should be always present when the fireplace is in operation.
- Make sure the pilot flame has two flame tips, one pointing to the flame sensor (thermocouple), and one to the center of the burner.
- Make sure the pilot area is clean from any dust, media or any other debris that may disrupt the operation of the ignition system. Lint or foreign material must be removed with a brush or vacuum.
- Verify fireplace ignition using the remote or wall switch. Verify electronic ignition, sparking sequence, pilot operation and burner ignition.

# FLARE

## FIREPLACES

---

### BURNER MAINTENANCE

- The flames from the burner should be visually checked. The flame should have a blue base and yellow tops and be candle-like in appearance.
- If excessive soot is found inside the firebox area, the fireplace will require adjustment. Verify the air shutter and vent restrictor setting and document any changes.
- If the flame becomes sooty, dark orange in color, or extremely tall, do not operate the heater.
- Measure and document the fireplace gas pressure.

Inlet: \_\_\_\_\_ W.C.

Outlet: \_\_\_\_\_ W.C.

### VENT MAINTENANCE

The following venting system inspection by a qualified service technician is recommended every six months:

- Inspect for excessive condensation, e.g., water droplets forming in the inner lining and subsequently dripping out of the joints. This can cause corrosion in the system.
- Check for corrosion in areas exposed to the elements. Where rust spots or holes have appeared, these must be immediately replaced.
- Ensure that there is no foreign material in the vents. Survey by removing the cap and shining a light down the vent.
- Check all joints and pipes to make sure that nothing has been disturbed or loosened.

# FLARE FIREPLACES

---

## DOUBLE GLASS FANS MAINTENANCE

- Disconnect power to the Flare control system.
- Remove the external glass and the covering trim.
- Inspect the fans around the Flare firebox and make sure they are all turning.
- Clean all fans with a brush and vacuum to remove any dust or debris.
- Inspect the lower fireplace intake. Clean the lower vent intake with a brush and vacuum any dust or debris.
- Connect back the Flare control power and press the Flare remote arrow down. Make sure all fans are working properly.
- Turn off the fans and install back the trim and glass.



# FLARE FIREPLACES

---

## MAINTENANCE LOG

The service technician should use the following document. A copy should be kept with the technician and owner for future reference.

### Flare Fireplaces – Maintenance Log

Service Date: \_\_\_\_\_

#### Unit Information

Model Type and Size: \_\_\_\_\_ Serial #: \_\_\_\_\_

#### Owner Information

Name: \_\_\_\_\_

Address \_\_\_\_\_

#### Technician Information

Name: \_\_\_\_\_ Company Name \_\_\_\_\_

Technician NFI # \_\_\_\_\_

#### Service Information

Yearly Maintenance: \_\_\_\_\_

Other: \_\_\_\_\_

Details: \_\_\_\_\_

\_\_\_\_\_

\_\_\_\_\_

\_\_\_\_\_

\_\_\_\_\_

# FLARE FIREPLACES

## WARRANTY POLICY

Flare Fireplaces subjects every fireplace and component to rigorous testing to verify it is free from any defects before it leaves our warehouse. Flare Fireplaces photographs and documents the fireplace and all components' moments before shipping them to our nationwide network of authorized dealers for installation, verifying full operation of the fireplace and all components. Our factory is supervised by CSA and subject to the highest operating standards.

## 18 MONTH COMPREHENSIVE WARRANTY

Effective beginning 18 months from the **original date of purchase from an authorized Flare Fireplaces Dealer**, our Comprehensive Warranty includes replacing or repairing any defective electronic components. These parts include the following components

- Gas Valve
- Receiver
- Remote
- LED Lighting Strips, Remote, & Controller
- Authorized Media
- Wall Switch
- Wi-Fi Components

**This warranty does not apply to any component that shows evidence of misuse, abuse, improper installation, exposure to water or moisture, excessive heat, dust, or paint.**

## LIMITED 5 YEAR COVERAGE

Effective for five years from the **original date of purchase**, Flare Fireplaces Limited Five-Year Coverage includes replacing both ceramic and tempered glass.

This coverage is warrantable under the following circumstances:

- Thermal Breakage Only

**This coverage is void if the glass is damaged due to construction, improper storage, pitting, transport, handling, or cleaning. This includes using ammonia or detergent based cleaning-solvents or solutions instead of lukewarm water and a lint free cloth. Other products may leave streaking or a honeycomb shaped stain on your fireplace glass.**

# FLARE FIREPLACES

---

## LIMITED 10 YEAR COVERAGE

Limited Lifetime Coverage is extended to the following components:

- Firebox
- Burners

## CONDITIONS

- **Warranty coverage begins on the date of original purchase.**
- Minor warping of certain components or discoloration is normal and is not considered a defect that is covered under this warranty. Major disruption and buckling of parts can be caused by over-firing of your fireplace. Over-firing above the rated value specified in the manual is contrary to the manufacturer's instructions and may void this warranty.
- All installations must be performed by a qualified technician in accordance with applicable local and national requirements.
- Installations must be done in accordance with the Flare Fireplaces installation manual. The Limited Warranty applies only if the product is installed in the United States or Canada and only if installed, operated, and maintained in accordance with the attached product manual.
- It is the responsibility of the installer to ensure the appliance is firing per the rating plate.
- Any part that is found in our judgment to be defective shall be repaired, replaced, or refunded at Flare Fireplaces' option.
- This warranty only covers appliances that are purchased through a Flare Fireplaces authorized dealer or distributor.
- The warranty is only valid while the appliance remains at the site of original installation.
- Flare Fireplaces does not install or provide installation services. The installation of the fireplaces must be done by an authorized installer. The fireplace limited warranty does not cover the installation service, or any part related to the installation of the fireplace or surrounding of the fireplace and venting.
- **Contact your dealer for a warranty service.** If the dealer is unable to provide necessary parts, contact the nearest Flare Fireplaces authorized dealer or supplier.

# FLARE

## FIREPLACES

---

### EXCLUSIONS

- This warranty does not apply to any component that shows evidence of misuse, abuse, improper installation, accident, or lack of maintenance.
- Flare Fireplaces is not responsible for televisions, mantels, surrounds or finishing material around the fireplace.
- Flare Fireplaces is not responsible for installation, operational or environmental conditions beyond our control.
- Flare Fireplaces shall in no event be liable for any special, indirect, or consequential damages of any nature which are more than the original purchase price of the product.
- Flare Fireplaces may at its discretion discharge all obligations by refunding the wholesale price of the defective part.
- This warranty may not be extended or modified by our dealers or representatives.
- The Limited Warranty only covers parts and labor as provided above. Flare Fireplaces will not be responsible for materials, components, or construction, which are not manufactured or supplied by Flare Fireplaces or for the labor necessary to install, repair or remove such materials, components, or construction.

### WARRANTY VOID WHEN

- An unauthorized media type is used in the firebox.
- The appliance has been over-fired or operated in atmospheres contaminated by chlorine, fluorine, or other damaging chemicals. Over-firing can be identified by, but not limited to, warped plates or pipes, rust colored iron or bubbling, cracking and discoloration of steel or enamel finishes.
- The appliance is subjected to prolonged periods of moisture or condensation.
- There is any damage to the appliance or other components due to water or weather damage, which is the result of, but not limited to, improper chimney or venting installation.
- Holes have been drilled into the fireplace for some reason.