



PRODIGY

Single Sided
See through

QUICK DIMENSIONS

	PC3		PC4		PC5		PC6		PC7		PC8	
	UNIT	FRAM.	UNIT	FRAM.	UNIT	FRAM.	UNIT	FRAM.	UNIT	FRAM.	UNIT	FRAM.
F.WIDTH	40 ¹ / ₄	42 ¹ / ₄	52 ¹ / ₄	54 ¹ / ₄	64 ¹ / ₄	66 ¹ / ₄	76 ¹ / ₄	78 ¹ / ₄	88 ¹ / ₄	90 ¹ / ₄	100 ¹ / ₄	102 ¹ / ₄
HEIGHT [°]	23 ¹ / ₄	26 ³ / ₁₆	23 ¹ / ₄	26 ³ / ₁₆	23 ¹ / ₄	26 ³ / ₁₆	23 ¹ / ₄	26 ³ / ₁₆	23 ¹ / ₄	26 ³ / ₁₆	23 ¹ / ₄	26 ³ / ₁₆
SS DEPTH	19 ⁷ / ₈	19 ¹ / ₄	19 ⁷ / ₈	19 ¹ / ₄	19 ⁷ / ₈	19 ¹ / ₄	19 ⁷ / ₈	19 ¹ / ₄	19 ⁷ / ₈	19 ¹ / ₄	19 ⁷ / ₈	19 ¹ / ₄
ST DEPTH	19 ⁷ / ₈	18 ⁷ / ₁₆	19 ⁷ / ₈	18 ⁷ / ₁₆	19 ⁷ / ₈	18 ⁷ / ₁₆	19 ⁷ / ₈	18 ⁷ / ₁₆	19 ⁷ / ₈	18 ⁷ / ₁₆	19 ⁷ / ₈	18 ⁷ / ₁₆
VIEWING	36 × H		48 × H		60 × H		72 × H		84 × H		96 × H	

Unit dimensions do not include mounting flanges

Standard

COOL-Pack glass system

Multi-color LED lighting

Intake dampers

Choice of glass media

Options

Speckled stones,
driftwood

Indoor-Outdoor seal kit
for see through units

Black reflective glass[†]

Flue gas dampers

[†] Standard in PC420 PC520
PC620 PC820

[°] Plus glass height

BTU LISTING

PC**3**N* / 40,000

PC**4**N* / 50,000

PC**5**N* / 75,000

PC**6**N* / 88,000

PC**7**N* / 100,000

PC**8**N* / 112,000

PC**3**L* / 31,000

PC**4**L* / 52,000

PC**5**L* / 64,000

PC**6**L* / 78,000

PC**7**L* / 105,000

PC**8**L* / 120,000

Features

All glass barriers, no screen required

Zero clearance

Compatible with home automation systems

Commercial grade valve, burner and control system



AVAILABLE DIMENSIONS

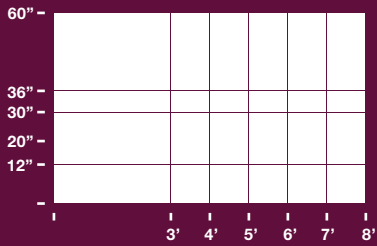

Indoor-Outdoor

Bridge the ample beauty of the outdoors with the comfort of your indoor space. Any size see-through prodigy can be transformed into a fully sealed indoor-outdoor unit with the addition of a kit.

Unit Specifications

	BTU Natural Gas	BTU Liquid Propane	Intake venting	Required B vent	Electrical requirements	Powevent Roof	Powevent Wall	Powevent Inline	Total area of free air intake
PC**3****	40,000	31,000	2 x 6"	8"	208-240 VAC Single Phase 15 Amp	PCSBFPV-R03-08	PCSBFPV-W03-08	PCINGPV-L03-08	56.52 sq.inches
PC**4****	50,000	52,000	2 x 8"	10"	208-240 VAC Single Phase 15 Amp	PCSBFPV-R03-10	PCSBFPV-W03-10	PCINGPV-L03-10	100.48 sq.inches
PC**5****	75,000	64,000	2 x 8"	10"	208-240 VAC Single Phase 15 Amp	PCSBFPV-R03-10	PCSBFPV-W03-10	PCINGPV-L03-10	100.48 sq.inches
PC**6****	88,000	78,000	2 x 8"	10"	208-240 VAC Single Phase 15 Amp	PCSBFPV-R03-10	PCSBFPV-W03-10	PCINGPV-L03-10	100.48 sq.inches
PC**7****	100,000	105,000	2 x 8"	10"	208-240 VAC Single Phase 15 Amp	PCSBFPV-R03-10	PCSBFPV-W03-10	PCINGPV-L03-10	100.48 sq.inches
PC**8****	112,000	120,000	2 x 10"	12"	208-240 VAC Single Phase 15 Amp	PCSBFPV-R03-12	PCSBFPV-W03-12	PCINGPV-L03-12	157 sq. inches

Body finish	Flue location	Intake vent locations:	COOL-Pack glass temperature	Burner style	Fuel	Controls	Control cable	Damper cable
Matte black	Top	Top both sides	As low as 115°F (46°C)	See chart	Natural gas or propane	On/Off wall switch, multifunction LED remote	50'	50'x2

PRODIGY QUICKSHIP

The following units are stocked and feature premium Glacier firestones and pre-installed black reflective glass panels. Natural gas only.
PC420 PC520 PC620 PC820

	PC3 BURNER STYLE	PC4 BURNER STYLE	PC5 BURNER STYLE	PC6 BURNER STYLE	PC7 BURNER STYLE	PC8 BURNER STYLE
60"	ribbon	high/low	high/low	high/low	high/low	high/low
36"	ribbon	high/low	high/low	high/low	high/low	high/low
30"	ribbon	high/low	high/low	high/low	high/low	high/low
20"	ribbon	high/low	high/low	high/low	high/low	high/low
12"	ribbon	ribbon	ribbon	ribbon	ribbon	ribbon



**RIBBON
BURNER**

**HIGH-LOW
BURNER**

Unit Dimensions

FLANGE DIMENSIONS

1" mounting flanges are removable and vary in location based on the unit configuration. Flanges on the Single sided and See through units are set back 5/8". Additionally, the flange on the top of all Prodigy configurations is set back 5/8".



PRODIGY SINGLE SIDED DIMENSIONS

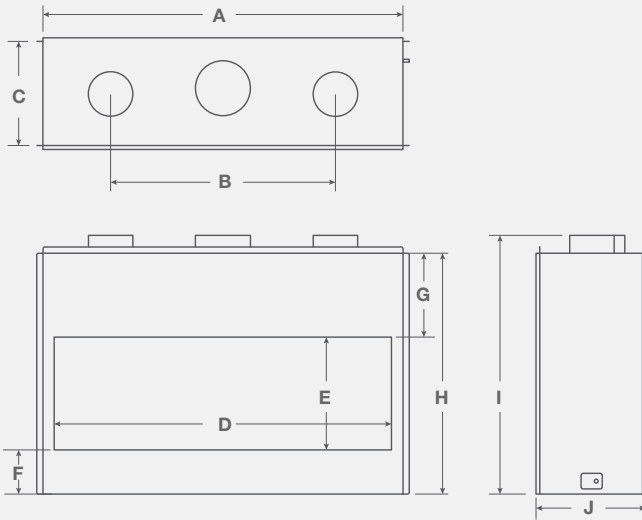

PRODIGY SEE THROUGH DIMENSIONS

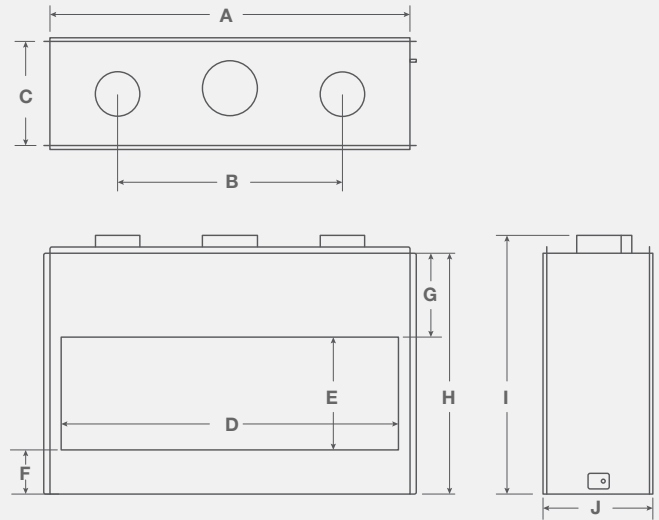

PRODIGY CORNER DIMENSIONS

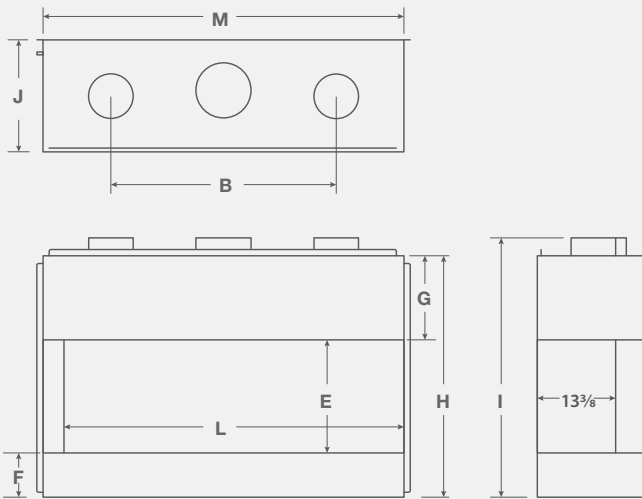

PRODIGY BAY DIMENSIONS

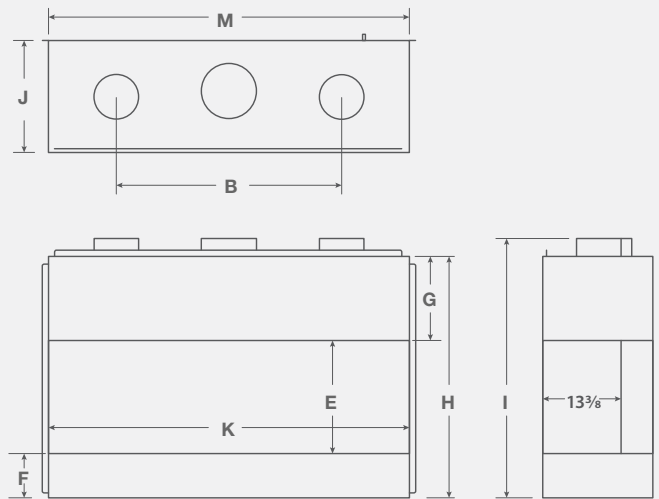

	AIR INTAKE	EXHAUST	A	B	C	D	E	F	G	H	I	J	K	L	M
8	2X10	12"	100 ¹ / ₄	60		95 ¹ / ₂							103 ¹ / ₂	99 ³ / ₄	103 ⁷ / ₈
7	2X8	10"	88 ³ / ₄	56		83 ¹ / ₂							91 ¹ / ₂	87 ³ / ₄	91 ¹ / ₈
6	2X8	10"	76 ³ / ₄	48		71 ¹ / ₂							79 ¹ / ₂	75 ³ / ₄	79 ⁷ / ₈
5	2X8	10"	64 ¹ / ₄	40	18 ³ / ₈	59 ¹ / ₂							67 ¹ / ₂	63 ³ / ₄	67 ⁷ / ₈
4	2X8	10"	52 ¹ / ₄	32		47 ¹ / ₂							55 ¹ / ₂	51 ³ / ₄	55 ⁷ / ₈
3	2X6	8"	40 ¹ / ₄	24		35 ¹ / ₂							43 ¹ / ₂	39 ³ / ₄	43 ⁷ / ₈

Unit Framing Rough-in

PRODIGY SINGLE SIDED FRAMING ROUGH IN

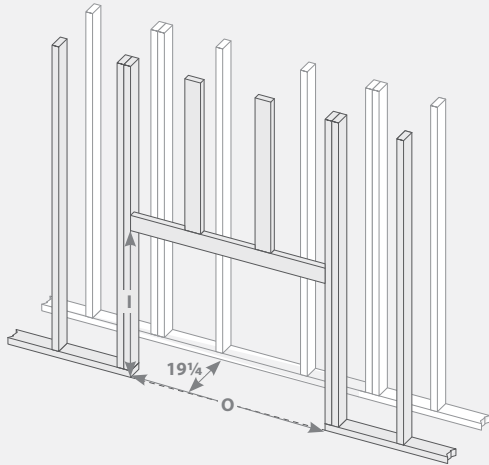

	3'	4'	5'	6'	7'	8'
O	42 ¹ / ₄	54 ¹ / ₄	66 ¹ / ₄	78 ¹ / ₄	90 ¹ / ₄	102 ¹ / ₄
I	26 ³ / ₁₆ + Glass Height					

PRODIGY SEE THROUGH FRAMING ROUGH IN

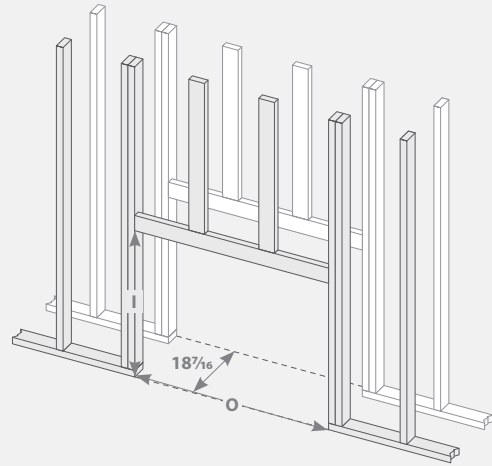

	3'	4'	5'	6'	7'	8'
O	42 ¹ / ₄	54 ¹ / ₄	66 ¹ / ₄	78 ¹ / ₄	90 ¹ / ₄	102 ¹ / ₄
I	26 ³ / ₁₆ + Glass Height					

“O” dimension allows the unit to be pushed into place with the mounting flanges still installed. Once the unit is in place, add studs behind the mounting flanges to properly secure.

PRODIGY CORNER FRAMING ROUGH IN

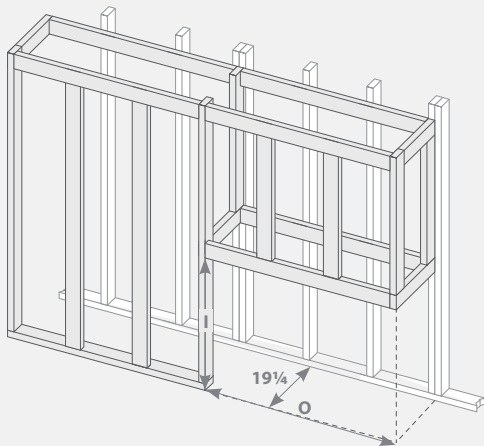

	3'	4'	5'	6'	7'	8'
O	43 ¹ / ₄	55 ¹ / ₄	67 ¹ / ₄	79 ¹ / ₄	91 ¹ / ₄	103 ¹ / ₄
I	26 ³ / ₁₆ + Glass Height					

PRODIGY BAY FRAMING ROUGH IN

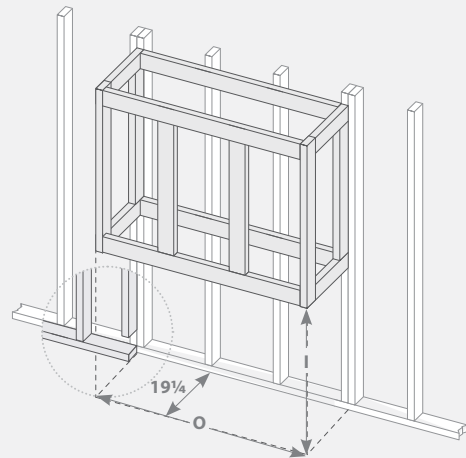

	3'	4'	5'	6'	7'	8'
O	42 ⁹ / ₁₆	54 ⁹ / ₁₆	66 ⁹ / ₁₆	78 ⁹ / ₁₆	90 ⁹ / ₁₆	102 ⁹ / ₁₆
I	26 ³ / ₁₆ + Glass Height					