

## LINEAR GAS FIREPLACE

## DIMENSIONS

PART	ACTUAL	FRAMING
FRONT WIDTH	51 $\frac{1}{8}$ "	59 $\frac{3}{4}$ "
BACK WIDTH	51 $\frac{1}{8}$ "	59 $\frac{3}{4}$ "
HEIGHT	41"	49 15/16"
DEPTH	17 $\frac{3}{4}$ "	17 11/16"
VIEWING AREA	36" X 14 $\frac{7}{8}$ "	N/A

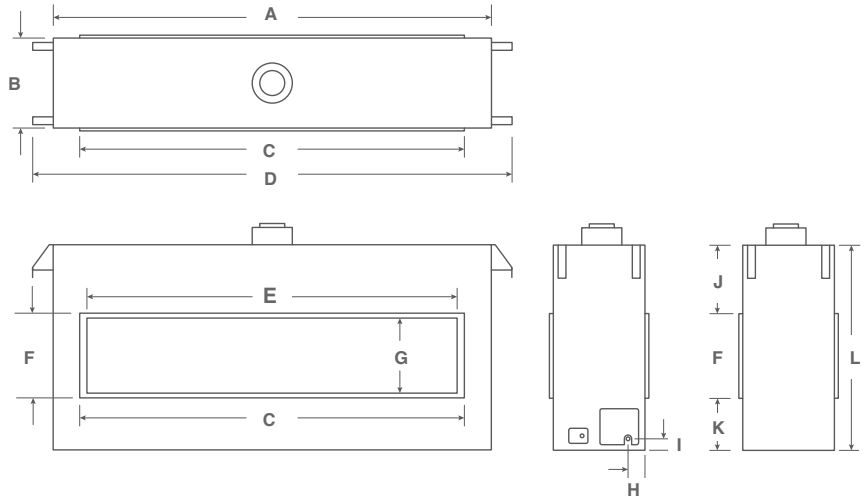

D3615 SEE THROUGH DIMENSIONS

A	B	C	D	E	F	G	H	I	J	K	L
51 $\frac{1}{8}$	17 $\frac{3}{4}$	40 $\frac{3}{4}$	59 $\frac{3}{4}$	37 $\frac{7}{8}$	17	15 $\frac{1}{2}$	8 $\frac{1}{8}$	2 $\frac{3}{8}$	13 $\frac{3}{8}$	10 $\frac{3}{8}$	41

## FEATURES

- 17 11/16" Framing Depth
- Montigo 4<sup>TH</sup> generation 35,000 BTU/HR concealed linear burner
- Standard 5/8 direct vent pipe
- Powervent capable to meet any vent configuration up to 100 feet
- Field convertible to propane with optional conversion kit
- Heat distribution kits for secondary heating

## TECHNICAL SPECIFICATIONS

### D3615ST Comes standard with:

- Full load Proflame2 control system and full function remote control
- 35,000 BTU/HR NG or LP Montigo 4<sup>TH</sup> generation linear concealed burner
- 30% turn down gas valve with stepper motor
- Ceramic glass doors with flush safety screens
- Black glass reflective liner kit
- Multicolor LED uplighting with remote control
- Star Ice fireglass media
- Cementboard facing

### D3615ST Options:

- Cool Wall Advantage TV kit
- Cool Wall Advantage side discharge kit

**LINEAR GAS FIREPLACE**

**FRAMING SPECIFICATIONS**

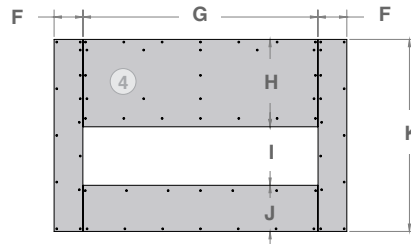
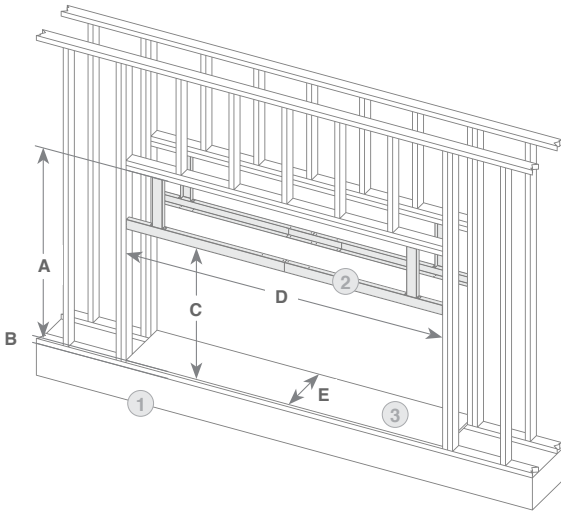

1	Floor structure
2	Non-combustible metal framing
3	Fireplace platform
4	Concrete board

D3615 SEE THROUGH DIMENSIONS

A	B	C	D	E	F	G	H	I	J	K
49 <sup>1</sup> / <sub>16</sub>	2 <sup>1</sup> / <sub>4</sub>	N/A	59 <sup>3</sup> / <sub>4</sub>	17 <sup>11</sup> / <sub>16</sub>	10 <sup>7</sup> / <sub>16</sub>	40 <sup>7</sup> / <sub>16</sub>	24	17 <sup>1</sup> / <sub>8</sub>	12 <sup>3</sup> / <sub>16</sub>	53 <sup>11</sup> / <sub>16</sub>



**SPECIFICATIONS**

- Sides: 4"
- Back: N/A
- Top : 8 15/16"
- Floor: 0"
- Facing Material: Cement board (Supplied)

Unit Code	BTU		Efficiency	
	High	Low	P.4. 1-02	Steady state
D3615NI	35,000	23,000	> 63%	> 70%
D3615LI	35,000	23,000	> 63%	> 70%

—  —

The perfect  
combination of  
performance  
and design

—