

INSTALLER:

Leave this manual with the appliance.

CONSUMER:

Retain this manual for future reference.



TOWN & COUNTRY
L U X U R Y F I R E P L A C E S

WARNING: If the information in these instructions is not followed exactly, a fire or explosion may result causing property damage, personal injury or death.

DANGER: If you smell gas:

1. Shut off gas to the appliance
2. Extinguish any open flame.
3. If odor continues, keep away from the appliance and immediately call your gas supplier or fire department.

WARNING: Do not store or use gasoline or other flammable vapors and liquids in the vicinity of this or any other appliance.

An LP-cylinder not connected for use shall not be stored

WARNING: Improper installation, adjustment, alteration, service or maintenance can cause injury or property damage. Read the installation, operating and maintenance instructions thoroughly before installing or servicing this equipment.

TC36 OUTDOOR GAS FIREPLACE INSTALLATION AND OPERATING INSTRUCTIONS



MODEL:
TC36.OD
SERIES C
MODULAR DIRECT VENT FIREPLACE

WARNING: For Outdoor Use Only

 **DANGER**



CARBON MONOXIDE HAZARD

This appliance can produce carbon monoxide which has no odor.

using it in an enclosed space can kill you.

Never use this appliance in an enclosed space such as a camper, tent, car or home.

SERIAL #



Installation and service must be performed by a qualified installer, service agency or the gas supplier.

Table of Contents

Caution	3
Safety	3
This Fireplace Intended For Outdoor Use Only	5
Propane Conversion	6
Fireplace Dimensions	7
Minimum Clearances to Combustible Material	7
Installation Requirements	8
Window Frame Removal.....	8
Top Standoffs.....	9
Locating The Fireplace	9
Framing and Finishing	10
TC36 Steel Stud Framing Kit.....	12
Adjustable Lintel	14
Hearth Extension.....	15
Honeywell Control Valve	16
Gas Supply	17
Gas Pressure Check.....	17
Venting.....	18
Wall Termination Venting	18
Wall Termination Venting Chart.....	21
Roof Termination Venting Chart.....	22
Vent Terminal Clearance.....	25
Vent Terminal Minimum Clearances	25
Vent Pipe Sealant.....	26
Insulated Collar Shield (Included).....	26
Vent Restrictor Adjustment	27
Firebox Panels Installation.....	28
Lighting Instructions	30
First Fire.....	30
Maintenance	31
TC36.CODE Replacement Parts.....	32
Replacement Parts – Honeywell Control System	33
Wiring Diagram.....	34
Wall Termination Kit	35
Roof Termination Kit	35
Wall Shield / Ceiling Firestop Thimble	35
Vent Pipe Dimensions	36
Vent Offset Chart.....	37
Safety Label Location.....	38

Caution

FOR YOUR SAFETY - Do not install or operate your Town & Country fireplace without first reading and understanding this manual. Any installation or operational deviation from the following instructions voids the Town & Country Fireplaces™ Warranty and may prove hazardous.

This appliance and its individual shut off valve must be disconnected from gas supply piping system during any pressure testing of that system at test pressures in excess of 1/2 psig (3.5 kPa).

This appliance must be isolated from the gas supply piping system by closing its individual manual shut off valve during any pressure testing of the gas supply piping system at test pressures equal to or less than 1/2 psig (3.5 kPa).

Note: When lit for the first time, the appliance will emit a slight odour for a couple of hours. This is due to the curing of paints, sealants and lubricants used in the manufacturing process. This condition is temporary. Open doors and windows to ventilate area. Smoke and fumes caused by the curing process may cause discomfort to some individuals.

Do not use the fireplace if any part has been under water. Immediately call a qualified service technician to inspect the fireplace and to replace any part of the control system and any gas control which has been under water.

Safety

Due to high temperatures, this gas appliance should be located out of traffic and away from furniture and draperies.

Children and adults should be alerted to the hazards of high surface temperatures and should stay away to avoid burns or clothing ignition.

Young children should be carefully supervised when they are in the same room as the appliance.

Clothing or other flammable material should not be placed on or near the appliance.

Any grill, panel or door removed for servicing the unit must be replaced prior to operating. Failure to do so may create a hazardous condition.

Installation and repair should be done by a qualified service person. The appliance should be inspected before use and at least annually by a professional service person. More frequent cleaning may be required due to excessive lint from carpeting, bedding material, etc.. It is imperative that control compartments, burners and circulating air passageways of the appliance be kept clean.

It is our policy that no responsibility is assumed by the Company or by any of its employees or representatives for any damages caused by an inoperable, inadequate, or unsafe condition which is the result, either directly or indirectly, of any improper operation or installation procedures.

This appliance must not be connected to a chimney flue serving a separate solid fuel burning appliance.



We recommend that our gas hearth products be installed and serviced by professionals who are certified in the United States by the National Fireplace Institute® (NFI) as NFI Gas Specialists

DANGER



HOT GLASS WILL CAUSE BURNS.

DO NOT TOUCH GLASS UNTIL COOLED.

NEVER ALLOW CHILDREN TO TOUCH GLASS.

A barrier designed to reduce the risk of burns from the hot viewing glass is provided with the appliance and shall be installed for the protection of children and other at-risk individuals.

WARNING: Solid fuels should not be burned in this appliance.

Warning:

This appliance is only for use with the type of gas indicated on the rating plate. This appliance is not convertible for use with other gases, unless a certified kit is used.

Important Note for the Commonwealth of Massachusetts:

From Massachusetts Rules and Regulations 248 CMR 5.08:

(a) For all side wall horizontally vented gas fuelled equipment installed in every dwelling, building or structure used in whole or in part for residential purposes, including those owned or operated by the Commonwealth and where the side wall exhaust vent termination is less than seven (7) feet above finished grade in the area of the venting, including but not limited to decks and porches, the following requirements shall be satisfied.

1. **INSTALLATION OF CARBON MONOXIDE DETECTORS.** At the time of installation of the side wall horizontal vented gas fuelled equipment, the installing plumber or gas fitter shall observe that a hard wired carbon monoxide detector with an alarm and battery back-up is installed on the floor level where the gas equipment is to be installed, in addition, the installing plumber or gas fitter shall observe that a battery operated or hard-wired carbon monoxide detector with an alarm is installed on each additional level of the dwelling, building or structure served by the side wall horizontal vented gas fuelled equipment. It shall be the responsibility of the property owner to secure the services of qualified licensed professionals for the installation of hard-wired carbon monoxide detectors.

a. In the event that the side wall horizontally vented gas fuelled equipment is installed in a crawl space or an attic, the hard-wired carbon monoxide detector with alarm and battery back-up may be installed on the next adjacent floor level.

b. In the event that the requirements of this subdivision cannot be met at the time of completion of installation, the owner shall have a period of thirty (30) days to comply with the above requirements; provided, however, that during said thirty (30) day period, a battery operated carbon monoxide detector with an alarm shall be installed.

2. **APPROVED CARBON MONOXIDE DETECTORS.** Each carbon monoxide detector as required in accordance with the above provisions shall comply with NFPA 720 and be ANSI/UL 2034 listed as IAS certified.

3. **SIGNAGE.** A metal or plastic identification plate shall be permanently mounted to the exterior of the building at a minimum height of eight (8) feet above grade directly in line with the exhaust vent terminal for the horizontally vented gas fuelled heating appliance or equipment. The sign shall read, in print size no less than one-half (1/2) inch in size, "GAS VENT DIRECTLY BELOW. KEEP CLEAR OF ALL OBSTRUCTIONS".

4. **INSPECTION.** The state or local gas inspector of the side wall horizontally vented gas fuelled equipment shall not approve the installation unless, upon inspection, the inspector observes carbon monoxide detectors and signage installed in accordance with the provisions of 248 CMR 5.089(2)(a) 1 through 4.

(b) **EXEMPTIONS.** The following equipment is exempt from 248 CMR 5.089(2)(a) 1 through 4.

1. The equipment listed in Chapter 10 entitled "Equipment Not Required To Be Vented" in the most current edition of NFPA 54 as adopted by the Board; and

2. Product Approved side wall horizontal vented gas fuelled equipment installed in a room or structure separate from the dwelling, building or structure used in whole or in part for residential purposes.

(c) **MANUFACTURER REQUIREMENTS – GAS EQUIPMENT VENTING SYSTEM PROVIDED.** When the manufacturer of Product Approved side wall horizontally vented gas equipment provides a venting system design or venting system components with the equipment, the instructions provided by the manufacturer for installation of the equipment and the venting system shall include:

1. Detailed instructions for the installation of the venting system design or the venting system components; and

2. A complete parts list for the venting system design or venting system.

(d) **MANUFACTURER REQUIREMENTS – GAS EQUIPMENT VENTING SYSTEM NOT PROVIDED.** When the manufacturer of a Product Approved side wall horizontally vented gas fuelled equipment does not provide the parts for venting the fuel gases, but identifies "special venting systems", the following requirements shall be satisfied by the manufacturer.

1. The referenced "special venting system" instructions shall be included with the appliance or equipment installation instructions; and

2. The "special venting systems" shall be Product Approved by the Board, and the instructions for that system shall include a parts list and detailed installation instructions.

(e) A copy of all installation instructions for all Product Approved side wall horizontally vented gas fuelled equipment, all venting instructions, all parts lists for venting instructions, and/or all venting design instructions shall remain with the appliance or equipment at the completion of the installation.

This Fireplace Is Intended For Outdoor Use Only!

- **The fireplace must be located inside of a weatherproof enclosure.**
- **Flashing must be installed around the fireplace opening in accordance with local building codes in order to prevent moisture from entering the enclosure.**
- **A drip pan (not supplied with the unit) must be installed under the fireplace and be provided with a means of draining.**
- **Care must be taken to select materials and building practices which will protect the enclosure and fireplace from exposure to moisture.**
- **Not for use with a power vent.**

Propane Conversion

Note: This fireplace comes with a preinstalled Honeywell pilot. When installing the burner assembly, remove the pilot that came attached to the burner and discard.

DO NOT USE ANY OTHER PILOT WITH YOUR OUTDOOR UNIT OTHER THAN THE HONEYWELL PILOT THAT CAME INSTALLED IN THE FIREPLACE.

1. Remove the compression fitting from the bottom of the orifice housing and gently tap the pilot in your hand. The natural gas orifice should fall out. Fig. #1

2. Insert the propane orifice that came in your instruction pack as shown into the orifice housing and reattach the pilot to the compression fitting and pilot tube. Fig. #2 & 3

3. Using the valve conversion kit that came in the instruction pack, convert the valve to propane following the instructions provided with the kit. Fig. #4

Fig. #2

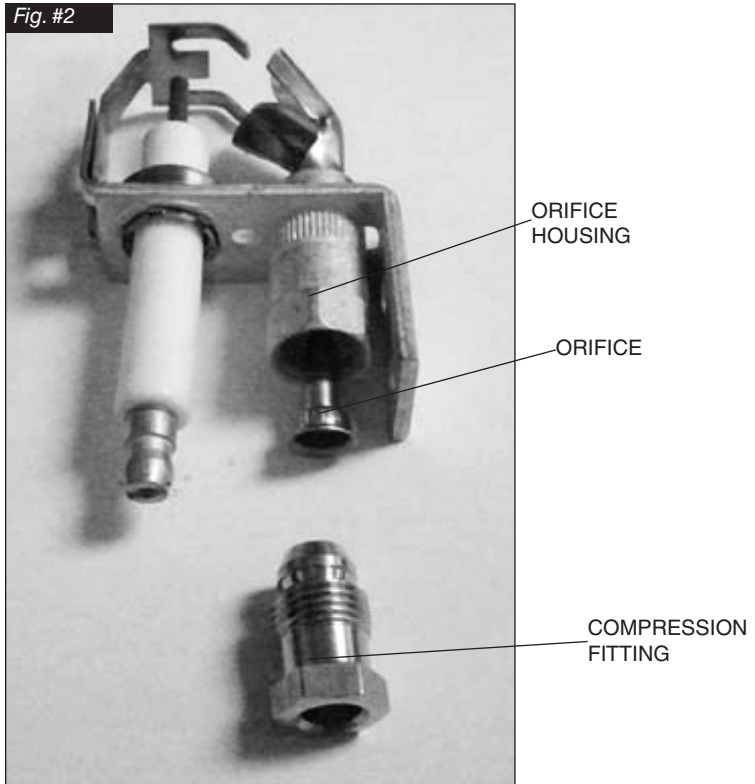

Fig. #1

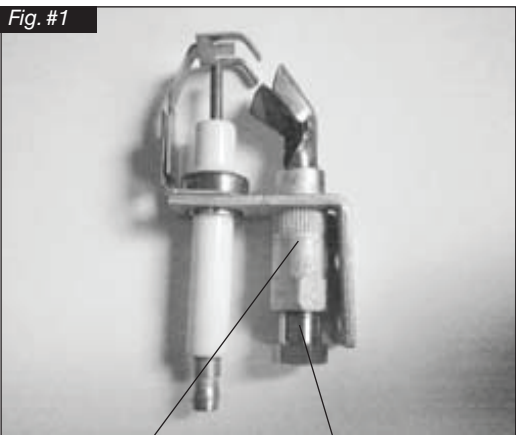

Fig. #3

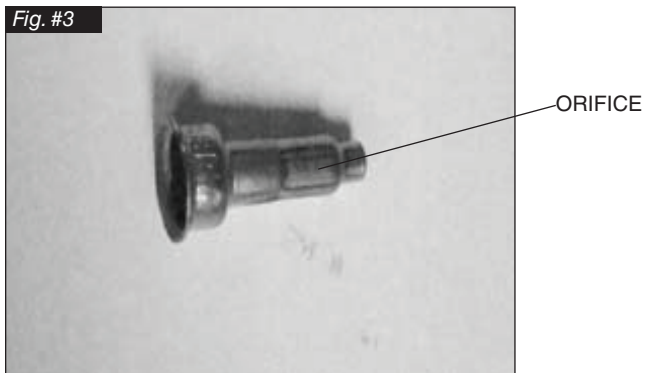
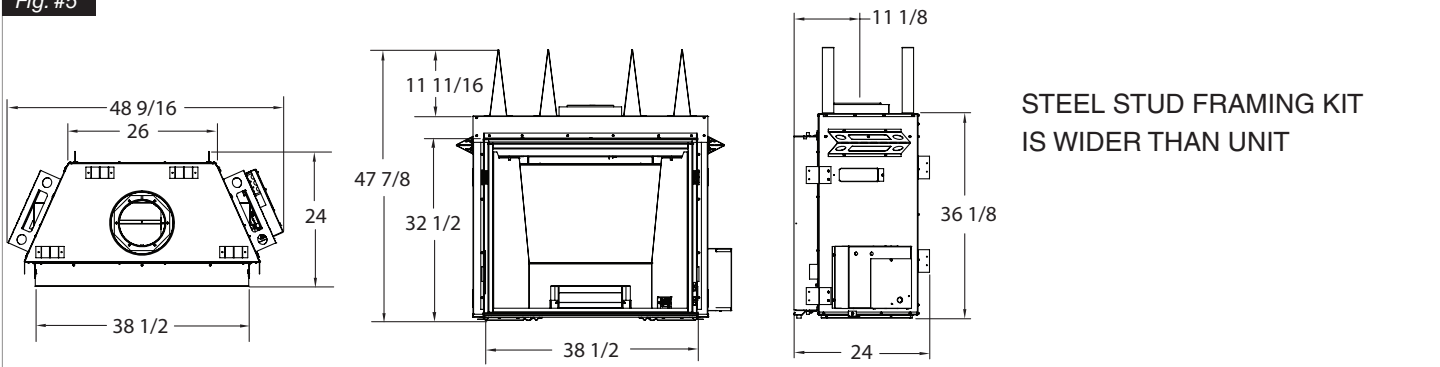

Fig. #4



Fireplace Dimensions

Fig. #5



Minimum Clearances to Combustible Material

Fig. #6

COMBUSTIBLE FRAMING AND FINISH WALL ABOVE STANDOFFS

MAY USE COMBUSTIBLE FACING MATERIAL IN THIS AREA

NON-COMBUSTIBLE FINISH MATERIAL SEE FIG #7

STEEL FRAMING

STANDOFFS

NON-COMBUSTIBLE ZONE. DO NOT INSTALL ANY COMBUSTIBLE MATERIAL, ELECTRICAL WIRING OR GAS PLUMBING IN THIS AREA.

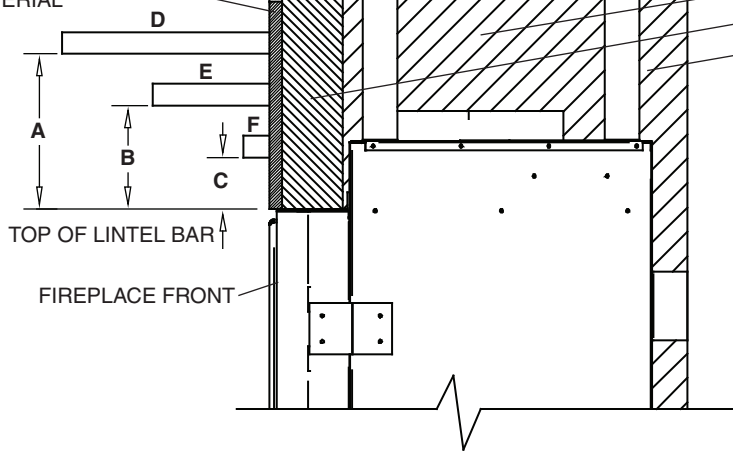

MANTEL CLEARANCE CHART

* MANTEL CLEARANCE

A	9"
B	6"
C	3"
** MANTEL DEPTH	
D	12"
E	6 3/4"
F	1 1/2"

Fig. #7

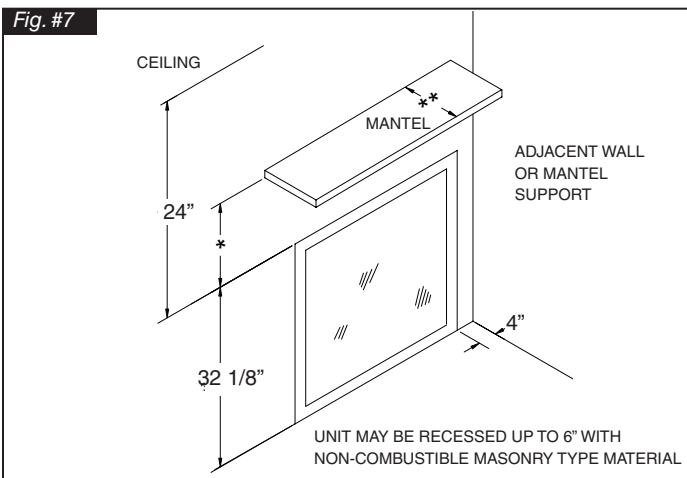

Minimum Clearances:

Side standoffs	0 in.	(0 mm)
Back standoffs	0 in.	(0 mm)
Top standoffs	0 in.	(0 mm)
Bottom of appliance	0 in.	(0 mm)
Adjacent side wall	4 in.	(102 mm)
Ceiling to appliance	24 in.	(610 mm)
*Mantel to appliance	See Figure #2	
**Maximum Mantel extension	See Figure #2	
Mantel support	4 in.	(102 mm)
Vertical vent pipe	1 3/4 in.	(45 mm)
Horizontal Vent pipe (Top, sides and bottom)	1 3/4 in.	(45 mm)

Installation Requirements

The Town & Country Fireplace installation and venting must conform to the current CAN/CGA-B149 installation code (in Canada) or the current National Fuel Gas Code, ANSI Z223.1 (in the USA), and approved per local codes. Only qualified (licensed or trained) personnel should install this product.

In the state of Massachusetts, only a licensed Plumber and Gas Fitter may install this product.

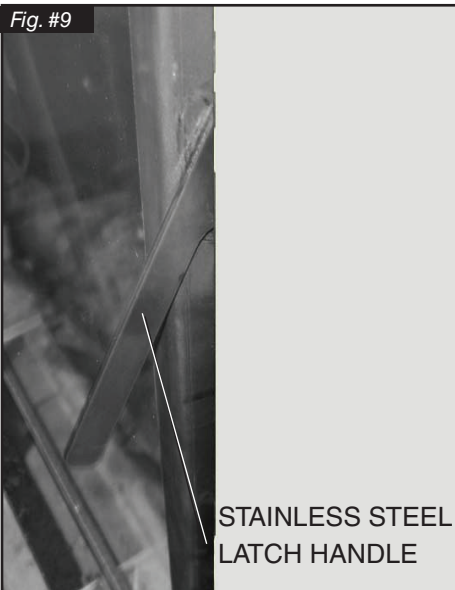

Window Frame Removal

Warning: Turn off the fireplace, and allow ample time for the unit to cool before proceeding.

Caution: The ceramic glass is very fragile, and should be handled with care.

The window frame is held in place by two spring-loaded latches that are operated by a one-piece latch handle.

1. Remove the TC Finishing Touch Trim Kit from the window frame. (If installed)
2. Using a screwdriver or other similar object, push against the notch in the top of the latch and grab the bottom of the latch handle as it protrudes. Lift handle until latch hook disengages. Repeat for other side while holding glass so it does not tip out.
3. Tilt the top of the window frame out to clear the top edge of the unit. Grasp the sides of the frame and lift up and out to disengage from its bottom track.
4. Place the window frame in a safe place to avoid damage.
5. Re-assemble in reverse order. Latch handle should snap into place and be flush with window frame when engaged correctly.

TIP:

To ensure glass is properly latched, grasp the top left and right sides of the glass frame, under moderate pressure it should pull forward and return to original position evenly on both sides.

6. Reinstall Trim Kit if required.

Top Standoffs

The top standoffs are shipped loose inside the fireplace and must be installed on top of the fireplace as shown in Fig #10. Do this once the fireplace is on site and in position.

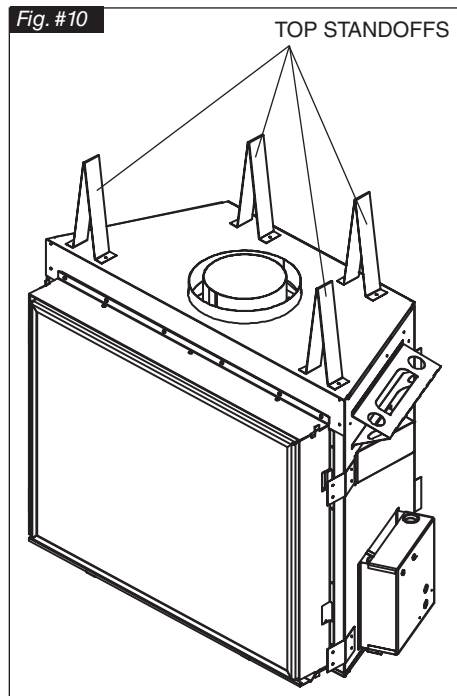

Locating The Fireplace

In planning the installation for the fireplace, it is necessary to determine where the unit is to be installed, location of vent system and where gas supply piping may be plumbed. Various installations are possible, such as, into an existing wall, a corner, a built-in wall or a wall projection (Fig #11). Due to high temperatures, do not locate this fireplace in areas of high traffic or near furniture or draperies.

The minimum clearances from the fireplace to combustible surfaces must be adhered to and are shown in Fig #6 and Fig #7.

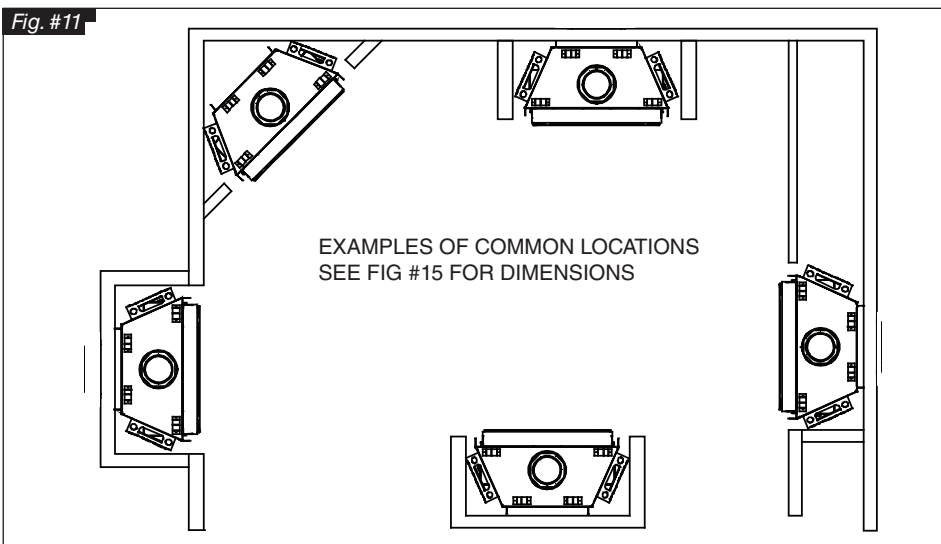

Framing and Finishing

Note: The fireplace should be in place and venting installed before framing in or building an enclosure around the unit.

The Town & Country fireplace must be framed in as described below or totally enclosed with non-combustible material, such as facing brick.

Determine the total thickness of facing material to be used. A thickness of 3/4" will allow the finishing surface to be flush with the front of the unit. If preferred, additional masonry type non-combustible material can be installed above and to the sides up to 6 inches proud of the appliance.

The finishing material must not interfere with glass frame access.

A Steel Stud Framing Kit is supplied with the fireplace and must be used unless the fireplace is totally enclosed with non-combustible material. Assemble the framing kit as per the instructions on pages 12 & 13 of this manual. Attach the steel frame to the fireplace once the fireplace is in its final

position. Secure the steel frame to the framing brackets on each side of the unit. Ensure that the studs are set back far enough to allow for thickness of finishing surface.

The sides, back and top of the fireplace can be framed in up to the steel studs and the fireplace standoffs using conventional lumber. Consult local building codes for specific requirements.

Due to high temperatures, non-combustible backer board, such as cement board or its equivalent, must be used to sheet in the front of the fireplace, extending 12" above and 5 9/16" to the side of the framing edge bars. (Fig #13) Standard sheet rock (dry wall) may be used beyond this.

If the backer board is not to be finished with other non-combustible material such as tiles, it is recommended that the instructions in Fig.#13a be followed closely.

Fabricate and install appropriate flashing to local building code.

Note: Installing unit without flashing installed will void the warranty

Note: Provide proper drainage to divert water underneath the unit

Chase Insulation: When installing this fireplace against a non-insulated exterior wall or chase, it is recommended that the outer walls be insulated to same degree as other exterior walls. Do not place fireplace directly against the insulation. Cover the insulation and plastic vapour barrier with a solid surface, such as dry wall (sheet rock). Consult local codes. Do not insulate or use plastic vapour barrier within the framing kit.

CAUTION: SEE FIGURE #13a BEFORE PROCEEDING.

Fig. #12

NON-COMBUSTIBLE ZONE. DO NOT INSTALL ANY COMBUSTIBLE MATERIAL, ELECTRICAL WIRING, INSULATION, PLASTIC VAPOR BARRIER OR GAS PLUMBING WITHIN THE STEEL STUD FRAMING

STEEL STUD FRAMING KIT DIMENSIONS (Supplied with fireplace)

ALL OTHER FRAMING CAN BE DONE WITH CONVENTIONAL LUMBER

IT IS HIGHLY RECOMMENDED THAT A FULL HEADER BE INSTALLED ABOVE THE METAL FRAMING KIT

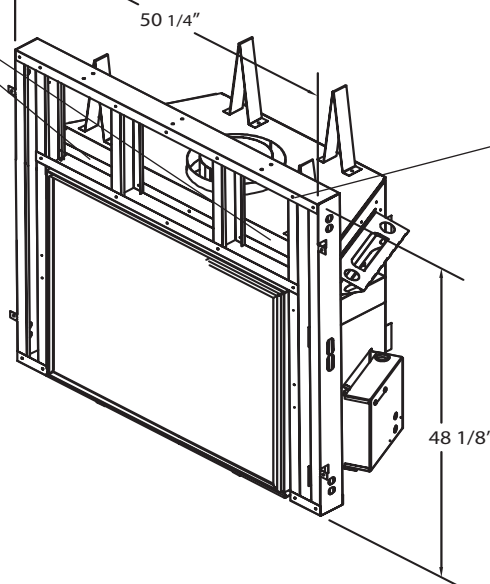

Fig. #13

NON-COMBUSTIBLE BOARD DETAIL

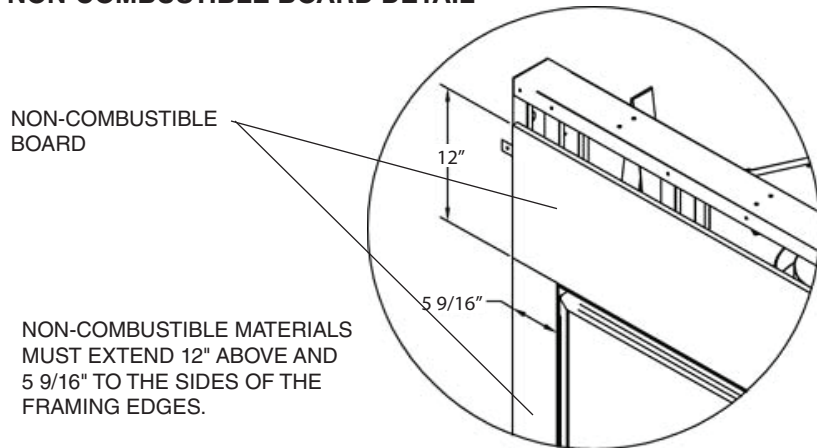

Fig. #13a

IF FINISHING THE WALL ABOVE THE UNIT WITH PAINT, THE FRAMING KIT SHIPPED WITH THE UNIT SHOULD BE DISCARDED.

IT IS RECOMMENDED TO USE FULL SHEETS OF CALCIUM SILICATE BOARD OR ITS EQUIVALENT AND FULL LENGTH METAL STUDS TO FINISH AND FRAME AROUND THE UNIT.

FOLLOW THE MANUFACTURERS MOUNTING AND FINISHING INSTRUCTIONS CLOSELY.

NOTE: IT IS RECOMMENDED TO PRE-DRILL MOUNTING HOLES IN THE BOARD PRIOR TO SECURING TO THE FRAMING. THIS WILL PREVENT THE BOARD FROM CRAKING.

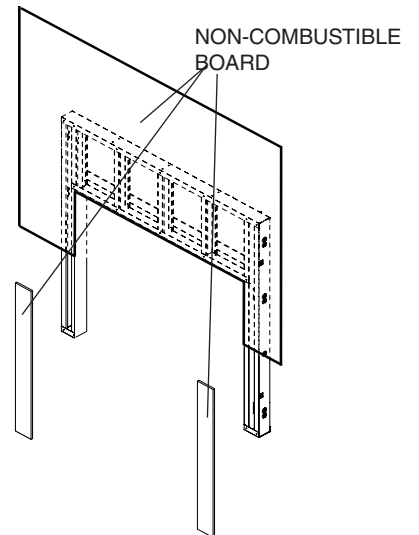

Fig. #14

NON-COMBUSTIBLE RECESSED INSTALLATION DETAIL

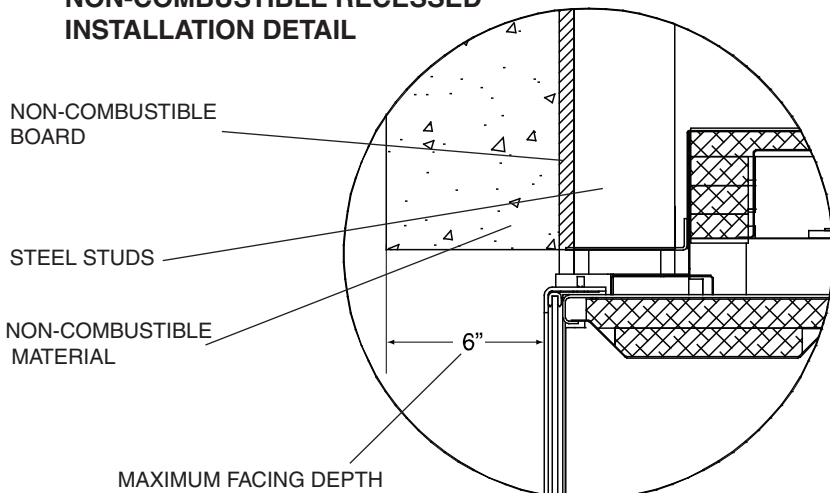
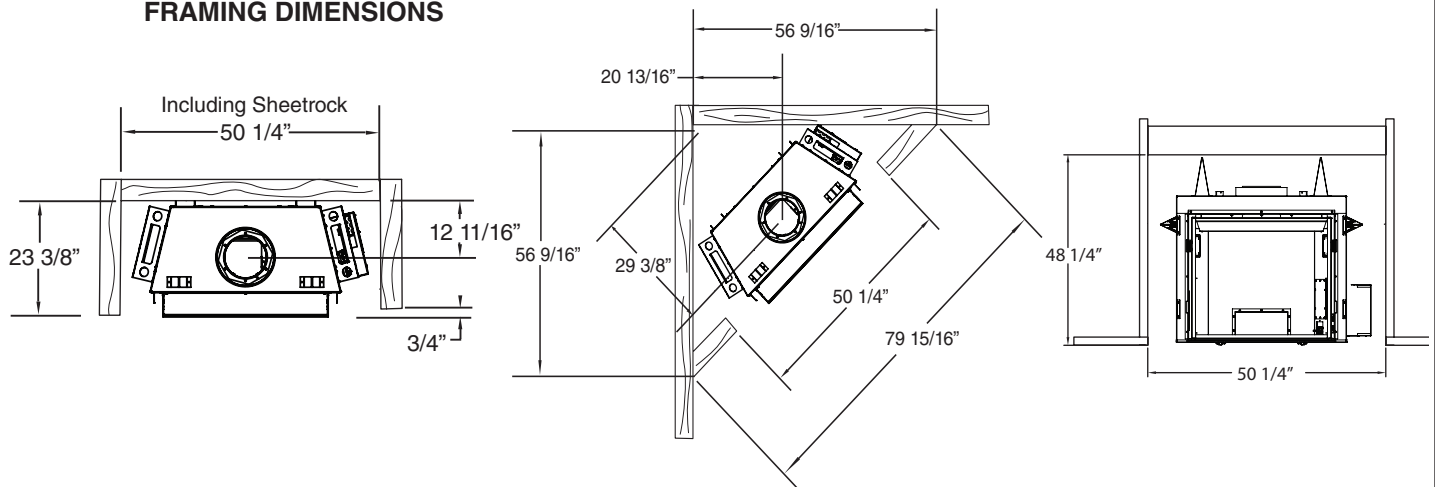

Fig. #15

MINIMUM COMBUSTIBLE FRAMING DIMENSIONS



NOTE: FIREPLACE SHOULD BE IN ITS FINAL LOCATION BEFORE FRAMING.

TC36 Steel Stud Framing Kit TC36.BFRKITA

Each Kit Contains:

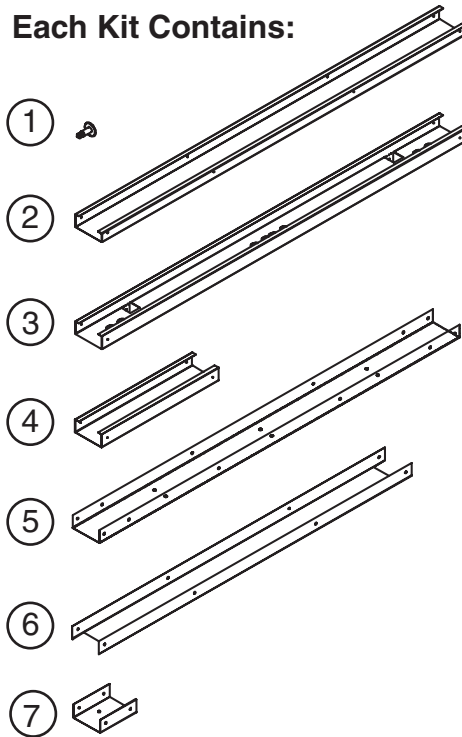

Item	Part #	Description	Qty.
1	5049.9912	SCREW, TEKS #8 x 1/2"	Pkg 40
2	9794.2	STUD, SIDES, 48"L	2
3	9794.5	STUD, OUTER SIDES, 48"L	2
4	9093.22	STUD, CENTER, 15 7/16"L	2
5	9193.501	STUD, HEADER, 49 7/8"L	1
6	9393.001	STUD, PLATE, 41 1/4"L	1
7	9194.5	BASE PLATE, 5 15/16"L	2

Fig. #16

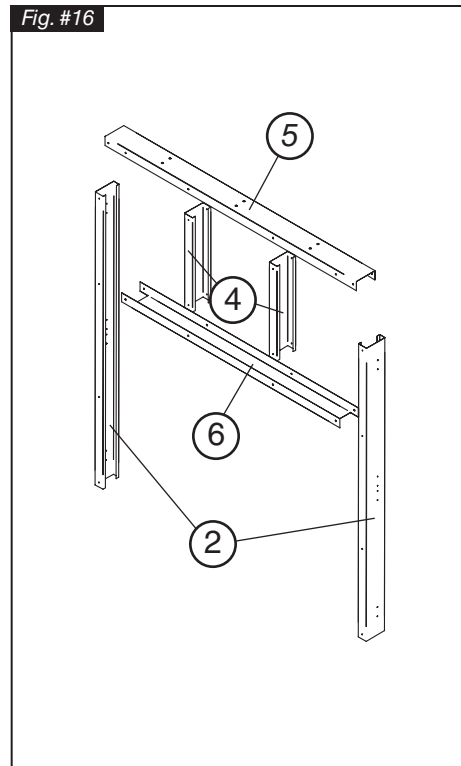

1. Top Frame Assembly

- Lay out side studs (2) and center studs (4) on a large flat surface. (Fig #16)
- Using the screws provided (1), attach the header stud (5) and the plate stud (6) to the center studs (4).

2. Attach Side Studs (Legs)

- Attach the outer side studs (3) to the top of the header stud (5). (Fig #17)
- Fasten the outer side studs (3) at the bottom using the base plates (7).

Fig. #17

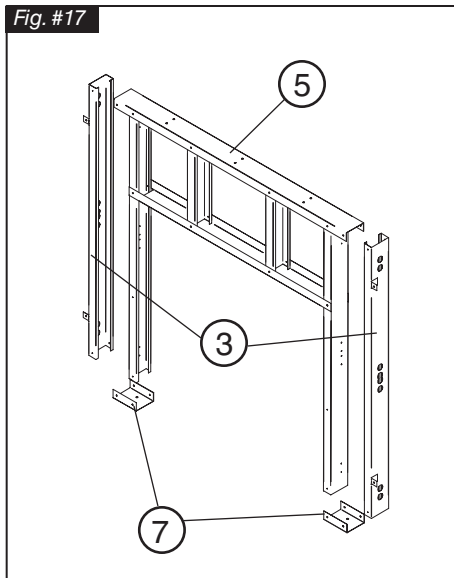

3. Attach the Assembled Frame to the Unit

- Align the assembled frame to the unit framing brackets. (Fig #18) Attach at the fastening points through the access holes in the outer side studs (3).

Fig. #18

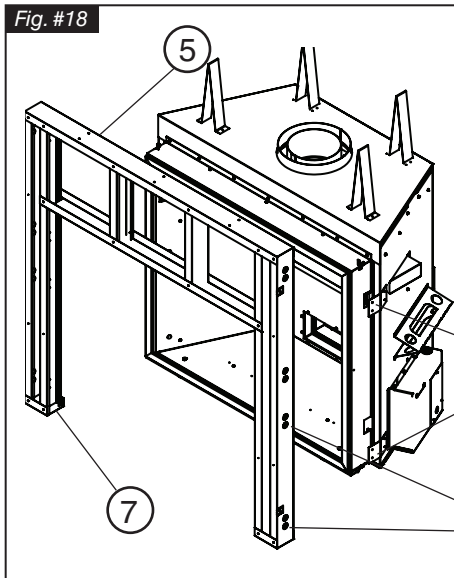

4. Secure to Existing Framing

- Secure the frame assembly to existing framing through the stud header (5) and the stud plates (7).

5. Install Non-combustible Board

- Use drywall screws to install the non-combustible board (Fig #19).

Fig. #19

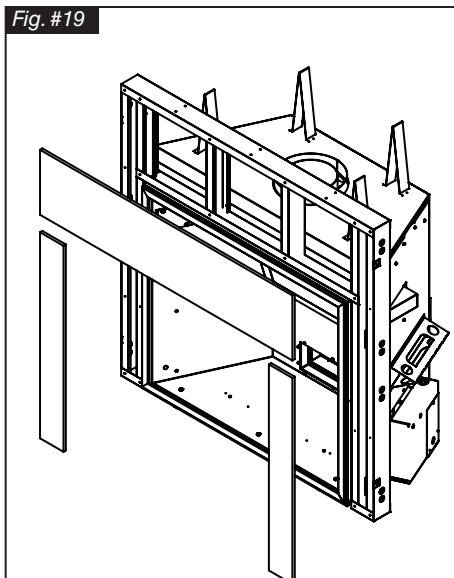

Adjustable Lintel

1. The adjustable lintel assembly has two orientations for desired finishing. A flanged edge and a hemmed edge. The lintel comes factory installed with the flange edge out. If the desired edge is different from the factory setting, use the following steps to change it (Fig.#20).
2. Remove the window trim by lifting and pulling to disengage from the window frame (Fig.#21).
3. Loosen the securing bolts in the upper and lower corners on each side of the lintel and remove the lintel. Rotate the assembly to have the desired edge away from the fireplace (Fig.#22).
4. The lintel assembly has a maximum range of adjustability of 1" to accommodate varying facing material thicknesses. The maximum depth is 6" (Fig.#24).
5. The lintel assembly can then be adjusted to align flush with your facing material by sliding in or out approximately 1"
6. Tighten the securing bolts. (Fig.#22).
7. Re-attach the window trim.

Fig. #20

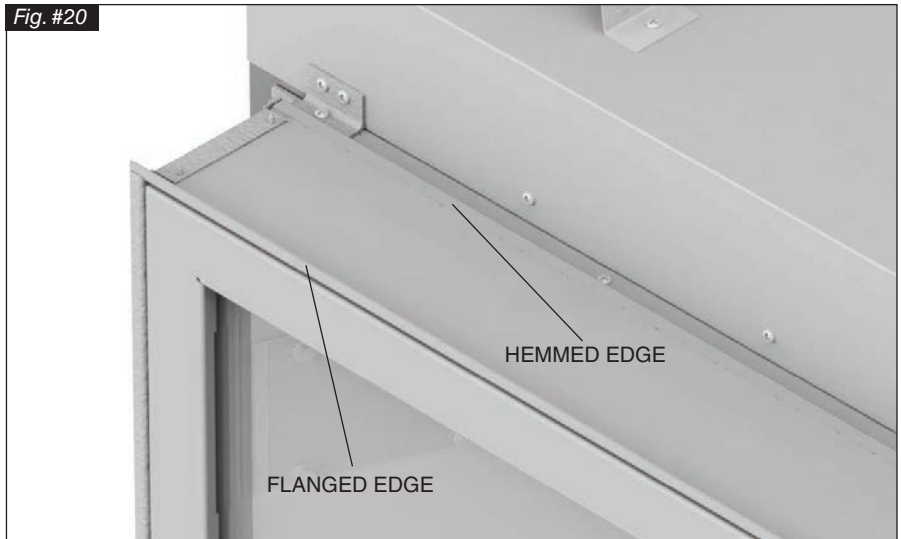

Fig. #21

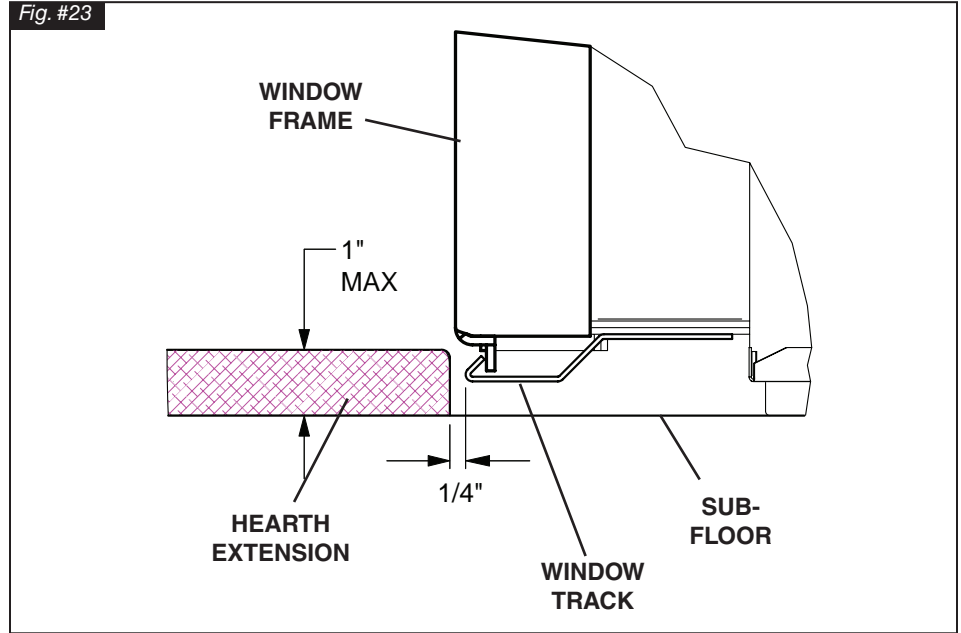

Fig. #22



Hearth Extension

Fig. #23



Caution: While a hearth extension is not required and combustible flooring materials may be brought directly up to the fireplace, many materials (such as wood flooring) may not tolerate the radiant heat from this fireplace, resulting in discoloration, shrinking and cracking. For this reason, we suggest a non-combustible hearth that is no more than 1" above the bottom of the fireplace. If thicker, fireplace must be raised accordingly.

Caution: Hearth extensions thicker than 1" will interfere with the window frame when opening.

This fireplace may be recessed up to a maximum depth of 6", this recess must be constructed from non-combustible material. The space between the outside framing edge and the firebox must be completely free of any obstructions or debris and the window, with trim fitted, must be able to move freely. No building material is permitted to protrude past the framing edges attached to the fireplace under ANY circumstance.

Fig. #24

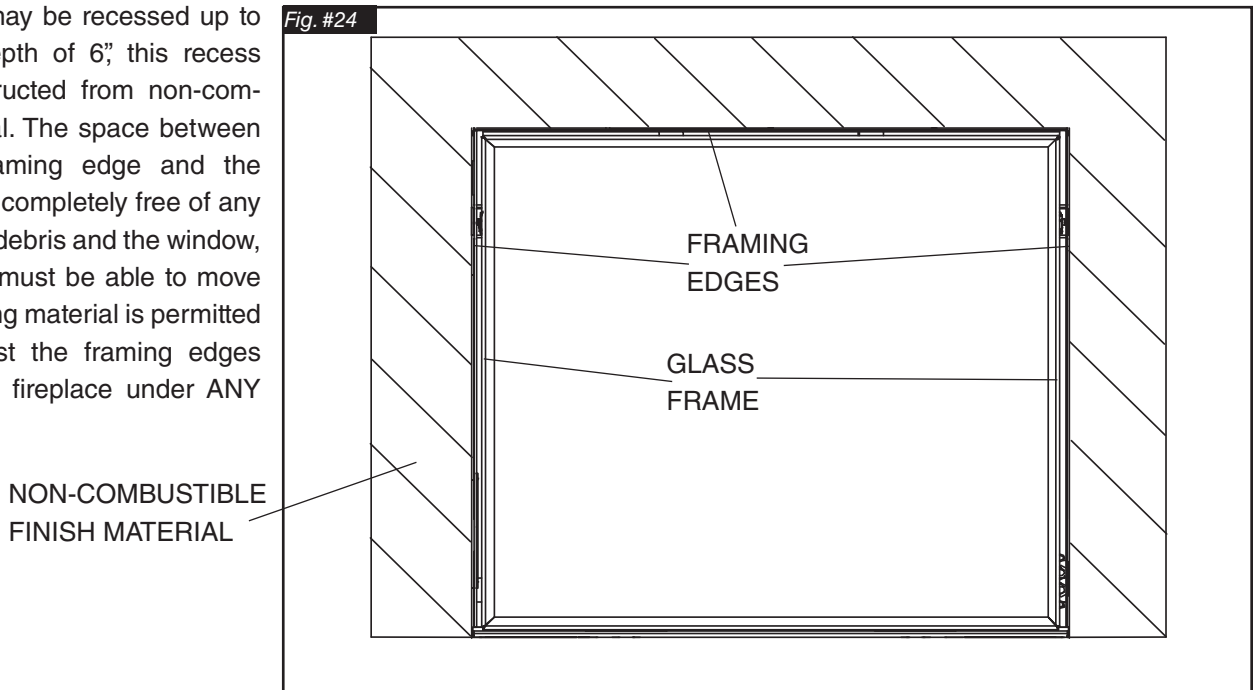

Honeywell Control Valve Plumbing and Electrical

The gas control system is located on the right hand side of the firebox behind an access panel and the decorative firebox panel (if installed). The fireplace is operated via a wall switch.

The wall control is connected to the fireplace by a 14-2 AWG wire, not supplied with the fireplace.

Installation

1. Place the fireplace in the desired location.
2. Remove the window from the fireplace.
3. Remove access panel from right hand side of the firebox (Fig #25).
4. Remove the cover from the electrical box Fig. #26.
5. Run two 110 V. AC switched electrical supplies to the control box and connect to the terminal block installed inside the control box(Fig #27). The fireplace operates on 24V AC supplied by a transformer rated at 110 volts, 60Hz. See wiring diagram on page #34 for correct connections on terminal block.
6. Connect the gas supply to the valve (Fig #28)

ACCESS PANEL

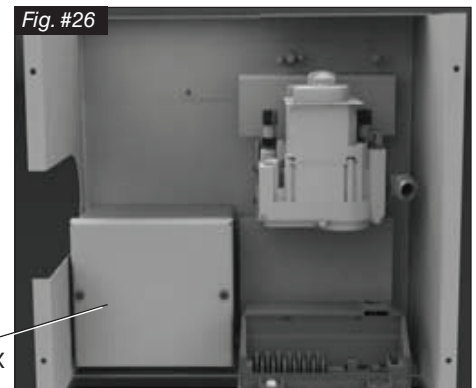

ELECTRICAL BOX
COVER

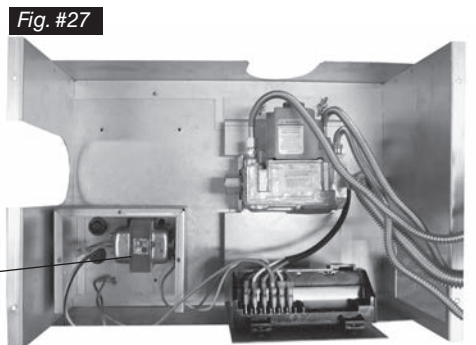

TRANSFORMER
ELECTRICAL CONNECTIONS

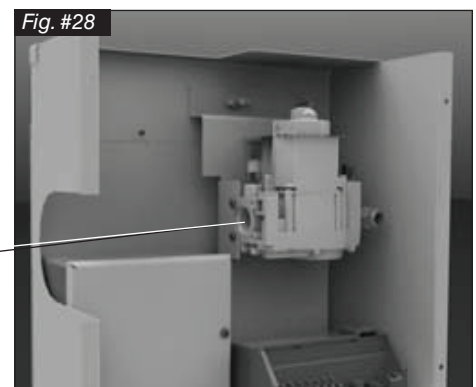

GAS INLET

Gas Supply

Caution: The gas line should be installed by a qualified service person in accordance with all building codes. This section is intended as a guide for qualified technicians installing this appliance. Consult local and / or national building codes before proceeding.

- Gas supply line access holes are located at the top and left sides of the Control Box. Gas valve inlet accepts a 3/8" N.P.T. fitting. Correct gas line diameter must be used to assure proper operation and pressure.
- The fireplace has an input rate of 47,000 BTU/HR on both Natural Gas and Propane.
- **NOTE: A sediment trap, as per national fuel gas code, must be installed in the gas supply line no more than 6 feet from the gas control valve to minimize the possibility of any loose scale or dirt within the gas supply line from entering the control valve.**
- **DO NOT HARD PIPE GAS LINE TO VALVE.** A method of disconnecting the valve from the gas line such as a union or flare fitting must be provided to allow for repair or replacement of the gas valve.

Check local codes for additional requirements.

1. Connect the gas supply to the valve (Fig. #28)
2. Turn on the gas supply and check that all connections are tight and leak free.

WARNING: Use EXTREME CAUTION when using soap and water to do a leak test on the valve/fittings. There are electronics around and below the valve, that can/will be damaged if they come in contact with water.

WARNING: The access panel including gasket must be reinstalled after conversion/installation or servicing has been completed. Failure to do so will cause overheating and premature failure of the control system.

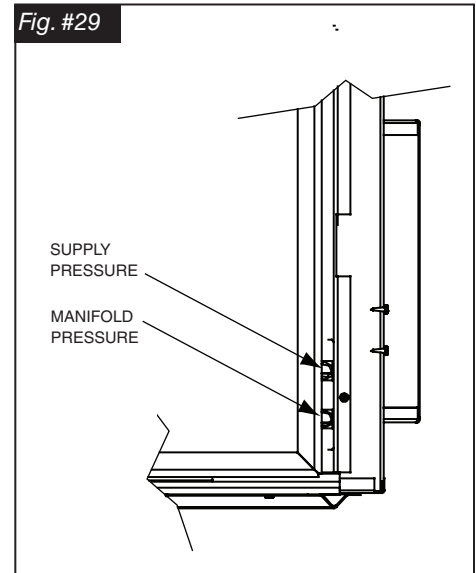

Gas Pressure Check

Note: To test the gas pressure, turn off the gas supply before removing the plug from the supply pressure test port or manifold pressure test port.

Verify gas pressures with the fireplace lit and on the highest setting.

Please refer to the Burner Installation Manual for gas pressure testing procedure.

Correct gas pressure requirement:

	Natural Gas	Propane
Min. Pressure <small>(For purpose of input adjustment)</small>	5.0" WC	12.5" WC
Max. Pressure	13.9" WC	13.9" WC
Manifold Pressure		
Maximum	3.8" WC	11" WC
Minimum	2.1" WC	5.5" WC

Venting

Before installing venting for this unit, the installer should read these instructions to insure that the proper vent configuration has been selected.

Use only Town and Country Termination kits #:

TCVT.WTA - Wall Termination Kit

TCVT.RTA - Roof Termination Kit

Vent system components approved for use with the Town and Country Fireplace are shown in Fig. #32.

Various combinations of vertical and horizontal runs may be used. Refer to Fig. #34 and 35 for details. For optimum performance and flame appearance, keep the vent length to a minimum and limit the number of elbows. Connections between each vent system component must be tightly joined, secured with sheet metal screws and sealed with high temperature self adhesive tape. A horizontal run of vent should have a 1/4" rise for every 1 ft. of run towards the termination.

CAUTION: UNDER NO CONDITION SHOULD COMBUSTIBLE MATERIAL BE CLOSER THAN 1 3/4 INCHES FROM THE TOP AND 1 3/4 INCHES FROM THE SIDES OF A HORIZONTAL SECTION AND 1 3/4 INCHES FROM THE VERTICAL SECTIONS OF THE VENT PIPE.

Wall Termination Venting

Exterior wall opening:

Determine the exact position of the fireplace so that the vent pipe is centered (if possible) between two building framing members. Consult your local building codes prior to proceeding. The vent kit will accommodate up to a maximum wall thickness of 12 inches.

1. Having determined the position of the fireplace, cut and frame a 14 1/2 inch opening centered at a minimum height of 68 1/2 inches above the floor. The opening may be round or square. Height of the opening will vary with each installation. As the horizontal vent run increases, so does the minimum vertical rise (see Fig. #34).

IMPORTANT: When locating the opening, it should be noted that vent terminal clearances must be maintained. See "Vent Terminal Clearances" section for proper clearances.

A minimum 2 foot length of pipe is required off the top of the fireplace for any wall termination. With this minimum vertical rise in combination with a 90° elbow, a maximum horizontal run of 18 inches is permitted (see Fig. #34). For longer horizontal runs greater than 18 inches, increase vertical rise appropriately.

The rise and run must be constrained to the boundaries of the chart shown in Fig. #34. The horizontal run of vent must have a 1/4" rise for every 1 ft. of run towards the termination.

Fig. #30

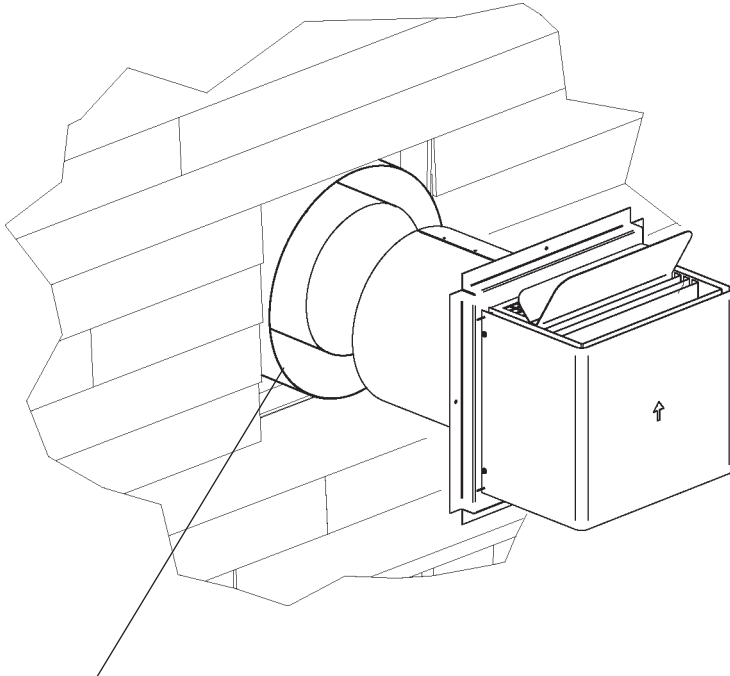

WALL THIMBLE AND VENT MUST NOT PROTRUDE BEYOND SIDING

Wall thimble:

Where a vent pipe passes through a combustible wall, a wall thimble/shield must be used to retain insulation and maintain proper clearances. The wall thimble may be cut to length for various wall thicknesses up to 12" thick.

Measure the wall thickness including the siding. Trim the shield to match the wall thickness. Position the wall thimble from inside through the 14-1/2" opening. Properly adjusted, the thimble should be flush with the outer wall surface.

Fig. #31

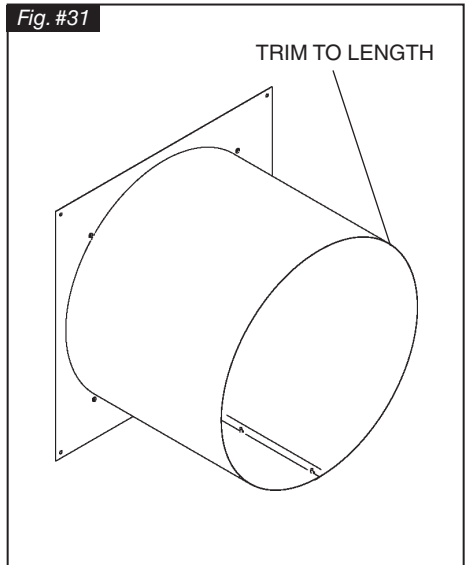

Fig. #32

Vent System Components

Town & Country

12" Pipe Length	TCVT.811X12
18" Pipe Length	TCVT.811X18
24" Pipe Length	TCVT.811X24
48" Pipe Length	TCVT.811X48
12" Adjustable Pipe Length	TCVT.811X12ADJ
45° Elbow	TCVT.811XLB45
90° Elbow	TCVT.811XLB90
Wall/Offset Support	TCVT.811XOS
Wall Termination Kit	TCVT.WTA
Roof Termination Kit	TCVT.RTA
Wall Shield/Ceiling Firestop	TCVT.THIMA
Roof Flashing, Adjustable	TCVT.811FLADJ
Roof Flashing, Flat	TCVT.811FLFLT
Roof Flashing, Steep	TCVT.811FLSTP
	or any flashing that fits 11" pipe

Vent pipe:

Install vent pipe through the wall thimble and attach to flue outlet collar on top of the fireplace. Secure all joints with screws and seal with approved "High Temp." self-adhesive aluminum tape provided.

Adjust the fireplace position so that the vent pipe does not protrude beyond the outer wall. The vent connector on the termination will accommodate walls up to 12" thick.

Wall vent terminal:

- 1) Engage the terminal with the vent pipe and slide terminal into place. Ensure that both inner and outer pipes are fully engaged and then attach the terminal to the outside wall. **The vent terminal must not be recessed into the exterior wall or siding.**
- 2) Caulk in place to prevent any moisture entering the building.

NOTE: MINIMUM CLEARANCES TO THE VENT TERMINAL MUST BE MAINTAINED (see Fig. #40 & 41).

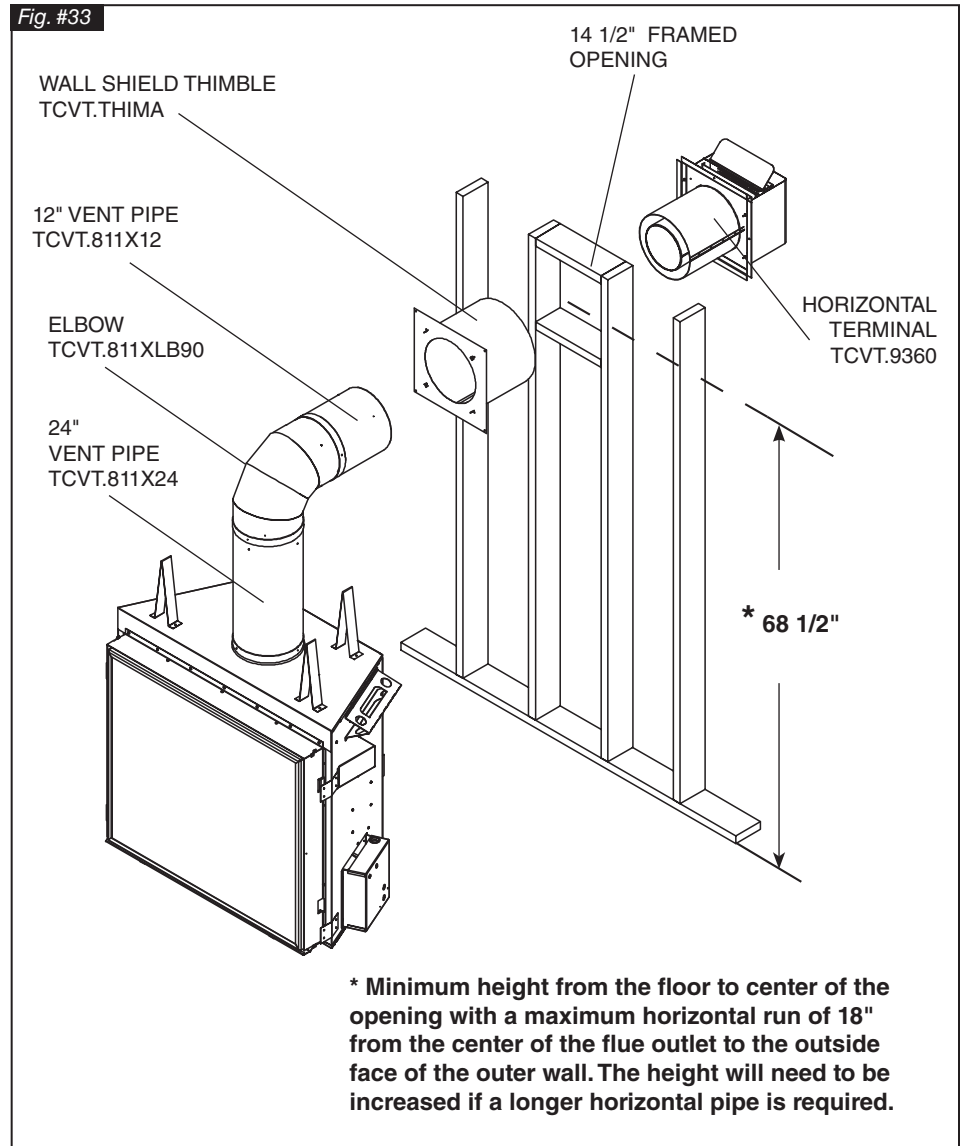

Wall Termination Venting Chart

Fig. #34

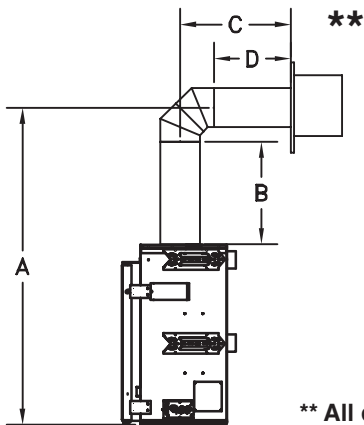

A Minimum rise	B Pipe length	C Maximum run	D Pipe length Max.
68 1/2"	1-24"	20 1/2"	1-12"
72 3/4"	1-12" 1-18"	75 3/4"	1-48" 1-12"
78 3/4"	1-24" 1-12"	11' 2"	2-48" 1-24"
84 3/4"	1-24" 1-18"	15' 10 1/2"	3-48" 1-24" 1-12"
92 1/2"	1-48"	20' 10 1/2"	5-48"

For other rise/run combinations see chart below

** All dimensions are approximate. Both rise and run may vary with different combinations of pipe.

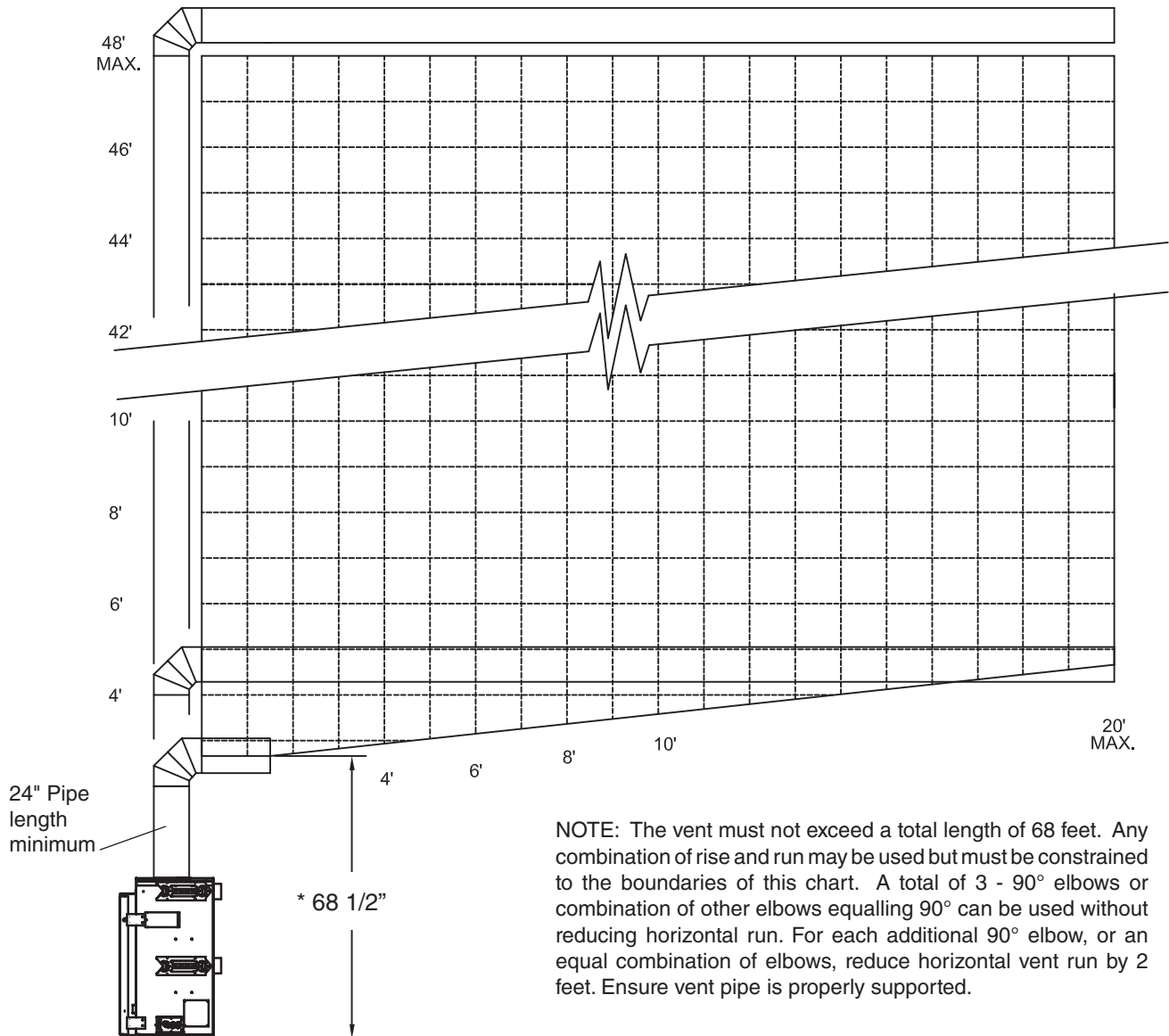

NOTE: The vent must not exceed a total length of 68 feet. Any combination of rise and run may be used but must be constrained to the boundaries of this chart. A total of 3 - 90° elbows or combination of other elbows equalling 90° can be used without reducing horizontal run. For each additional 90° elbow, or an equal combination of elbows, reduce horizontal vent run by 2 feet. Ensure vent pipe is properly supported.

Roof Termination Venting Chart

Fig. #35

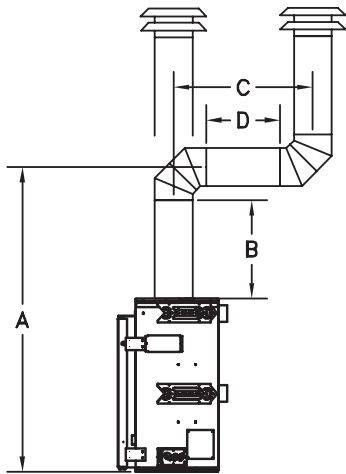

**

A Minimum rise	B Pipe length	C Maximum run	D Pipe length Maximum
68 1/2"	1-24"	29"	1-12"
72 3/4"	1-12" 1-18"	75 1/4"	1-48" 1-12"
78 3/4"	1-24" 1-12"	11' 1 1/2"	2-48" 1-24"
84 3/4"	1-24" 1-18"	15' 10"	3-48" 1-24" 1-12"
92 1/2"	1-48"	20' 10"	5-48"

For other rise/run combinations see chart below

** All dimensions are approximate. Both rise and run may vary with different combinations of pipe.

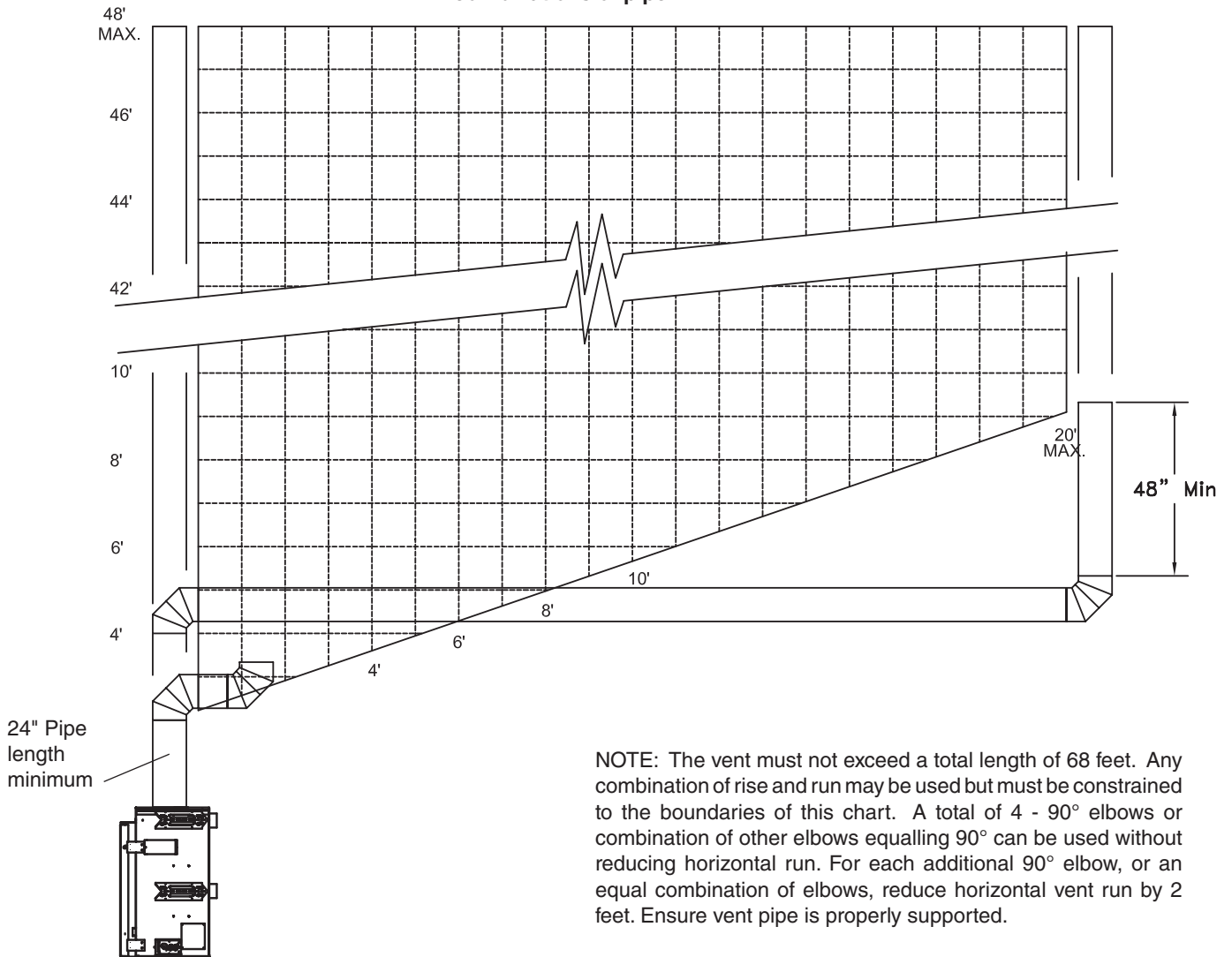
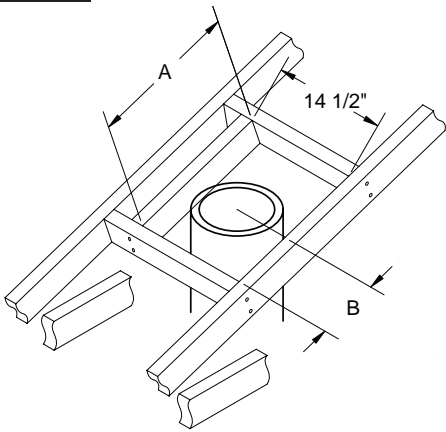

Fig. #36



Size of the opening will have to increase with the pitch of the roof to ensure a 1 3/4" inch air space clearance between vent pipe and combustibles.

Roof Pitch	A	B
0/12	14 1/2"	7 1/4"
4/12	16 1/2"	8 3/4"
6/12	18"	10"
8/12	19 3/4"	11"
12/12	24"	13 3/4"

Ceiling Opening:

1. Determine the exact position of the fireplace so that the vent pipe is centered (if possible) between two building framing members. Lay out the vent system path, minimizing the number of elbows and length of vent. Consult your local building codes prior to proceeding.
2. Cut and frame a 14 1/2" opening in the floor, ceiling or roof where the vent system will pass. Size of the opening in the roof may need to be increased as the pitch of the roof increases. Avoid cutting rafters.

Ceiling Firestop:

Where a vent pipe passes through a floor or ceiling, a ceiling firestop must be used to retain insulation and maintain proper clearances.

From below, push the ceiling firestop through the opening and secure in place. If the firestop is used to penetrate a floor, the outer shield may be trimmed in length. If the firestop penetrates into an attic, leave the shield full length to keep insulation away from the vent pipe. Additionally, after the vent pipe is in place, install a storm collar on top of the shield. This will prevent loose insulation from falling into the area between the vent pipe and the shield.

Fig. #37

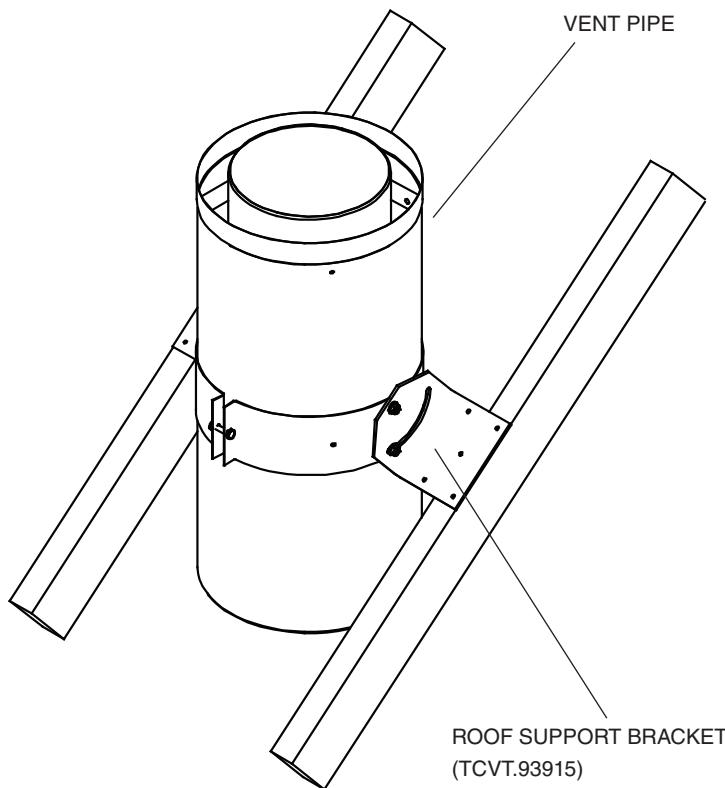

Vent Pipe:

1. Install the first section of vent pipe into the collar on top of the fireplace. Secure in place with screws and seal with approved "High Temperature" self-adhesive aluminium tape provided.
2. Continue adding vent pipe lengths up and through the firestop(s) and through the roof. The vent pipe must extend at least 24" above the roof.

Seal the vent pipe as per "Vent Pipe Sealant" section.

Roof Support Bracket:

Slip the roof support bracket down over the vent pipe. Rotate the 90° brackets to accommodate roof pitch. Attach the brackets to the roof joists with nails or building screws. Tighten the band around the vent pipe and secure in place with screws.

Roof Vent Terminal:

1. Place the roof flashing over the vent pipe, secure and seal it to the roof using the methods and materials appropriate for the type of roof on the building. Shingle roof example shown (Fig #38).
2. Place the storm collar down over the vent pipe until it is level. Tighten storm collar for a snug fit. Apply a thick horizontal ring of mastic around the pipe at top of the storm collar (Fig #38).
3. Lower the roof vent terminal cap over the vent pipe and secure in place with screws provided (Fig #38). Seal screw heads and joints with caulking to prevent any moisture entering the venting system.

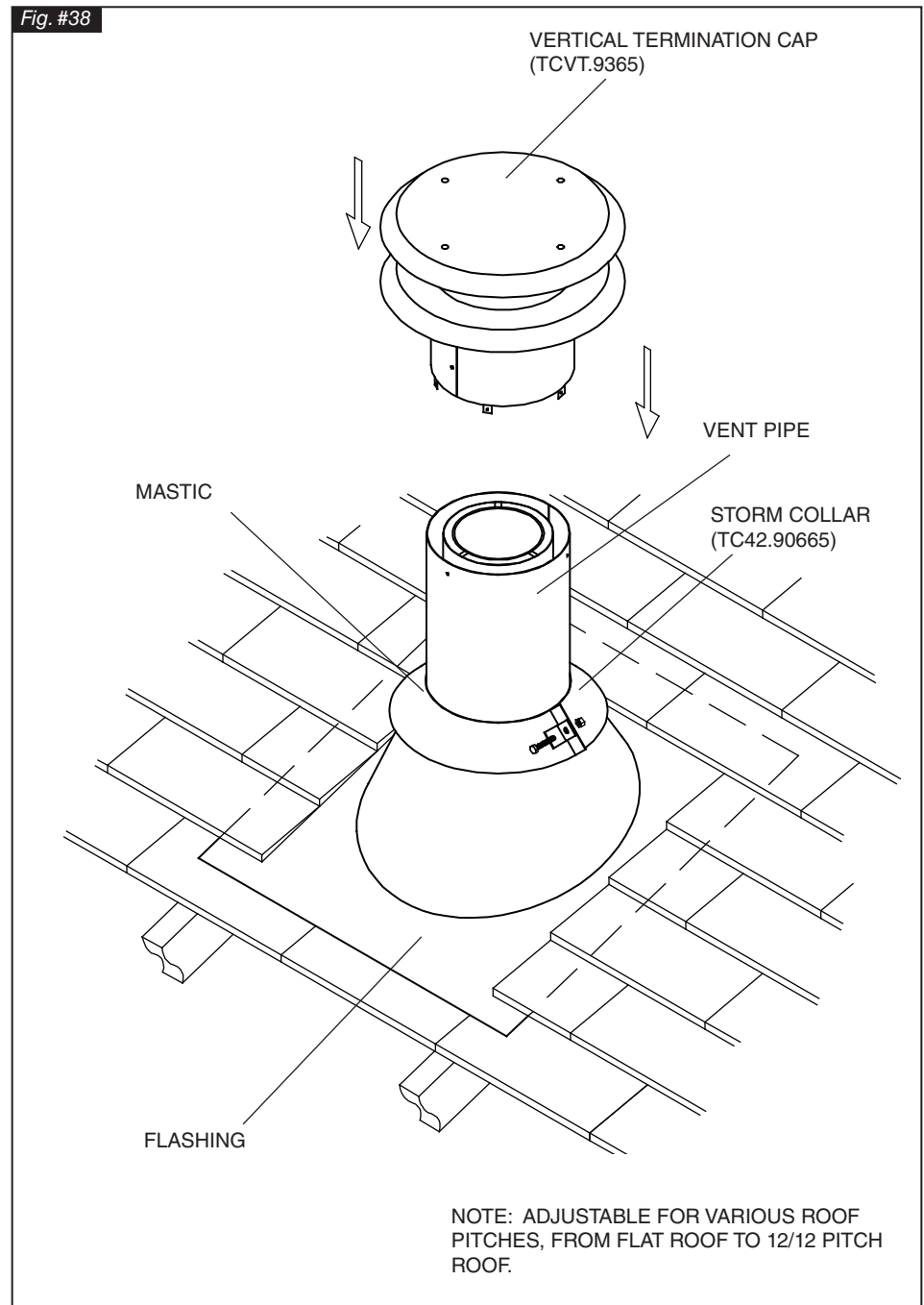

Vent Terminal Clearance

Minimum clearances to the vent terminal must be maintained as shown in figure #40 & 41. Measure clearances to the nearest edge of termination hood.

NOTE: Vent terminal must not be recessed

NOTE: LOCAL CODES OR REGULATIONS MAY REQUIRE DIFFERENT CLEARANCES.

Fig. #39

Roof Pitch Table	(minimum)	
	ft	m
Flat to 6/12	1.00	0.30
Over 6/12 to 7/12	1.25	0.38
Over 7/12 to 8/12	1.50	0.46
Over 8/12 to 9/12	2.00	0.61
Over 9/12 to 10/12	2.50	0.76
Over 10/12 to 11/12	3.25	0.99
Over 11/12 to 12/12	4.00	1.22

Fig. #40 VENT TERMINAL MINIMUM CLEARANCES TO ADJACENT STRUCTURES

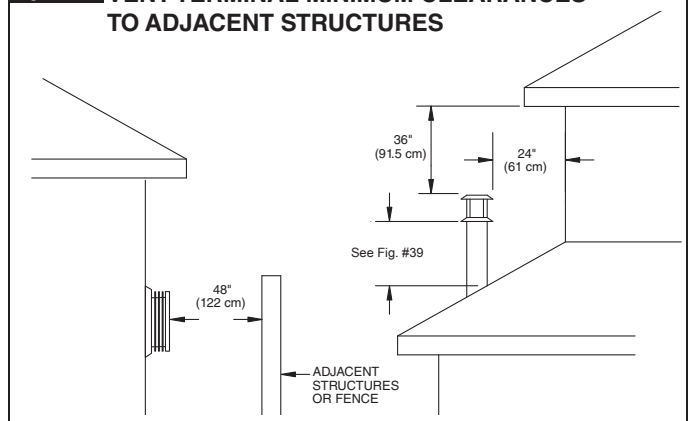

Vent Terminal Minimum Clearances

Fig. #41

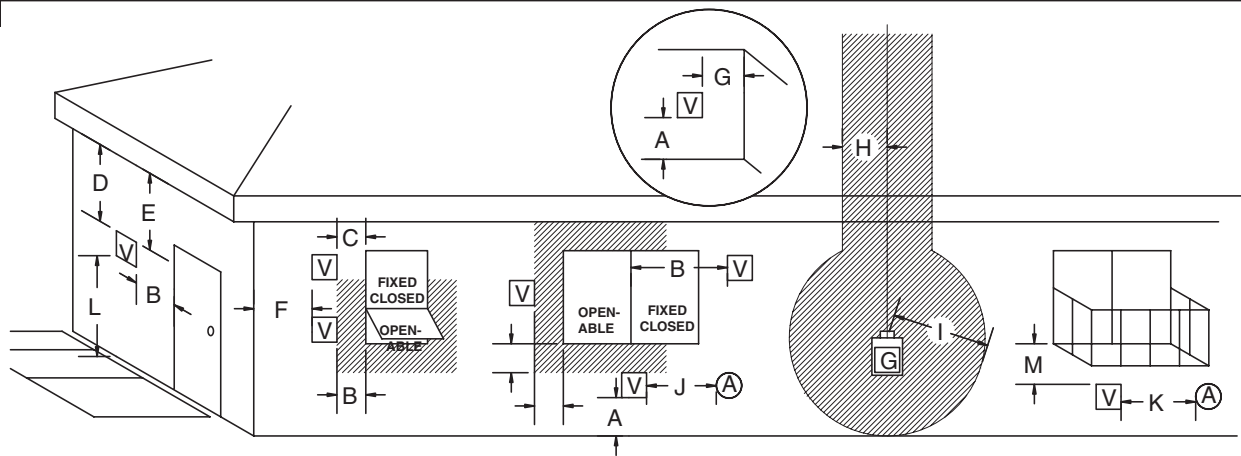

V VENT TERMINAL
 A AIR SUPPLY INLET
 AREA WHERE TERMINAL IS NOT PERMITTED
 G GAS METER

A=	*12 inches (30 cm) min.	Clearances above grade, veranda, porch, deck, or balcony
B=	*12 inches (30 cm) min.	Clearance to window or door that may be opened
C=	12 inches (30 cm) min.	Clearance to permanently closed window recommended to prevent condensation on window
D=	30 inches (76 cm) min.	Vertical clearance to ventilated soffit located above the terminal within a horizontal distance of 2 feet (60 cm) from the edge of the terminal
E=	30 inches (76 cm) min.	Clearance to unventilated soffit
F=	6 inches (15 cm) min.	Clearance to outside corner
G=	6 inches (15 cm) min.	Clearance to inside corner
H=	3 feet (90 cm) min.	*Not to be installed above a meter/regulator assembly within 3 feet (90 cm) horizontally from the center-line of the regulator
I=	*6 feet (1.8 m) min.	Clearance to service regulator vent outlet
J=	*12 inches (30 cm) min.	Clearance to non mechanical air supply inlet to building or the combustion air inlet to any other appliance
K=	*6 feet (1.8 m) min.	Clearance to a mechanical air supply inlet
L=	*7 feet (2.1 m) min.	^ Clearance above paved side-walk or a paved driveway located on public property
M=	**30 inches (76 cm) min	Clearance under veranda, porch, deck, or balcony

^ a vent shall not terminate directly above a side-walk or paved driveway which is located between two single family dwellings and serves both dwellings*

** only permitted if veranda, porch, deck, or balcony is fully open on a minimum of 2 sides beneath the floor*

* as specified in CGA B149 Installation Codes, Note: local Codes or Regulation may require different clearances

* for U.S.A. Installations follow the current National Fuel Gas Code, ANSI Z223.1

Vent Pipe Sealant

Fig. #42

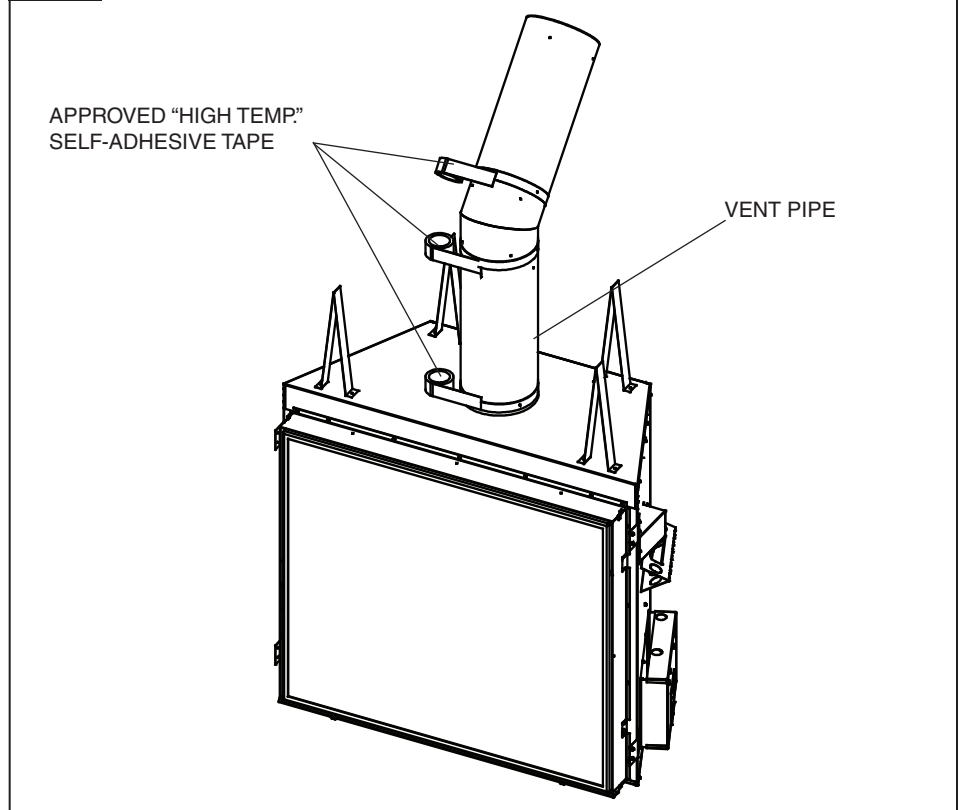

All outer joints of the vent pipe must be sealed with the approved "High Temperature" self-adhesive aluminium tape provided. Wrap the tape completely around the joint and press firmly in place.

Insulated Collar Shield (Included)

After sealing the vent pipe an insulating blanket and cover (Pt# TC36.9709 included) **must be installed** around the vent pipe, flush with the top of the unit and secured by fitting tabs through slots and bending over tabs 180° as shown in Fig. #43. The parts required are included.

*NOTE: bending tabs to 90° away from arc bend prior to installation eases the process.

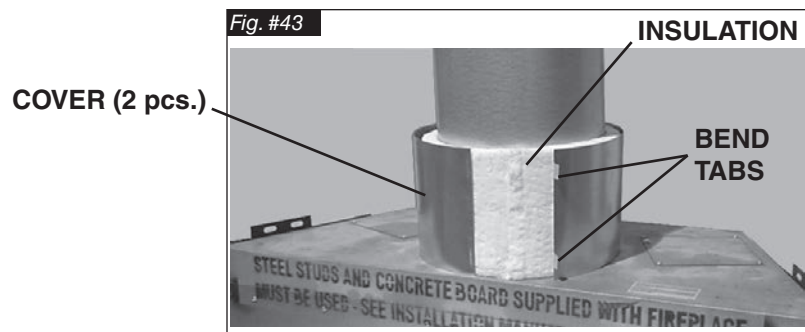

Vent Restrictor Adjustment

The vent restrictor is located on the underside of the firebox top. The unit leaves the factory with the vent restrictor open. The restrictor is built into the appliance for secondary air flow adjustment. Adjustment enables tuning the airflow for optimum flame appearance and performance for a wide variety of vent configurations.

Setting:

- determine the vent height.
- determine the vent horizontal length.
- from the chart determine the restrictor position.

Refer to the chart in Fig. #44 for the correct position of restrictor for the vent configuration of your installation. Restrictor positions are based upon lab tests. The ideal position may vary slightly with installation.

Restrictor position is too closed if the flame has the following characteristics:

- Flame is excessively tall and lifting.
- Flame lacks movement.
- Flame soots.

Restrictor position is too open if the flame has the following characteristics:

- Flame height is low.
- Flame has excessive movement.

To adjust the restrictor:

- Loosen the screw holding the restrictor.
- Move the restrictor to its intended opening.
- Re-tighten the screw.

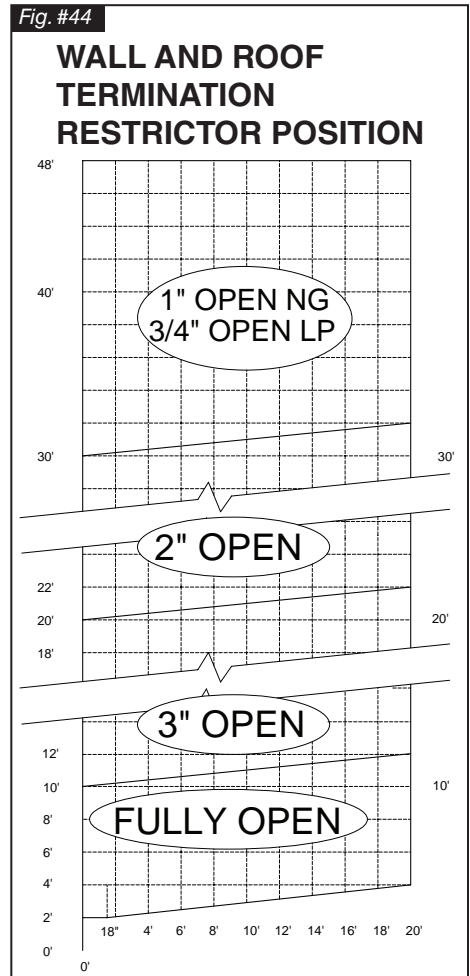

OPENING

VENT RESTRICTOR

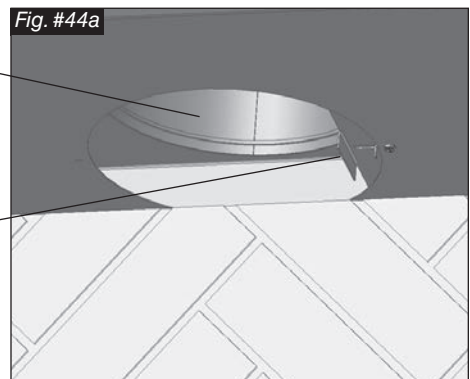

Firebox Panels Installation

(See Porcelain panel instruction manual for specific instructions for these panels) Before proceeding see burner instructions.



ADJUSTABLE "V" BRACKET
REAR LOWER PANEL

The lower rear panel is held tight against the side panels by two "V" brackets located on the firebox rear wall. Although the brackets are adjusted at the factory for the best fit, some adjustment may be necessary. Adjust the angle of the bracket by hand to ensure a snug fit.

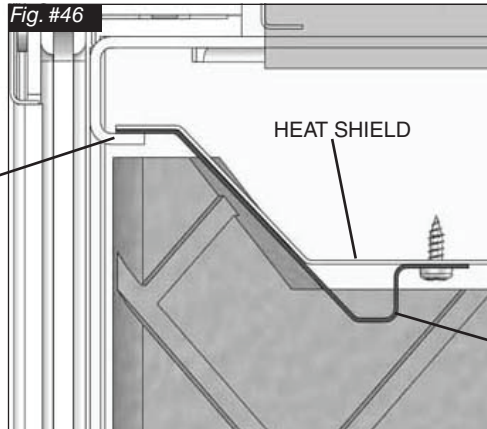

A Firebox Panel Set must be installed for safe operation. Do not use the fireplace without panels. Unpack and inspect all panels. The panels need to be installed before the logs are in place.

Caution: The Firebox Panels are very fragile, and should be handled with care.

1. Remove the Side Panel Retainer located on the underside of the firebox heat shield. The retainer slips between the lip of the firebox and the heat shield and is retained in place by two screws (Fig. 46 & Fig. 47).
2. Install the Lower Rear Panel.



SCREWS

3. Install the Right Side Panel by inserting the bottom of the panel in first and then angling it up into position. It may be necessary to push the firebox shield up to allow panel to move freely into place.
4. Install the Rear Upper Panel.
5. Install the Left Side Panel by inserting the bottom of the panel in first and then angling it up into position.
6. Re-install the Side Panel Retainers.
7. Install the Left and Right Front Panels.

(HERRINGBONE PANEL SET SHOWN)

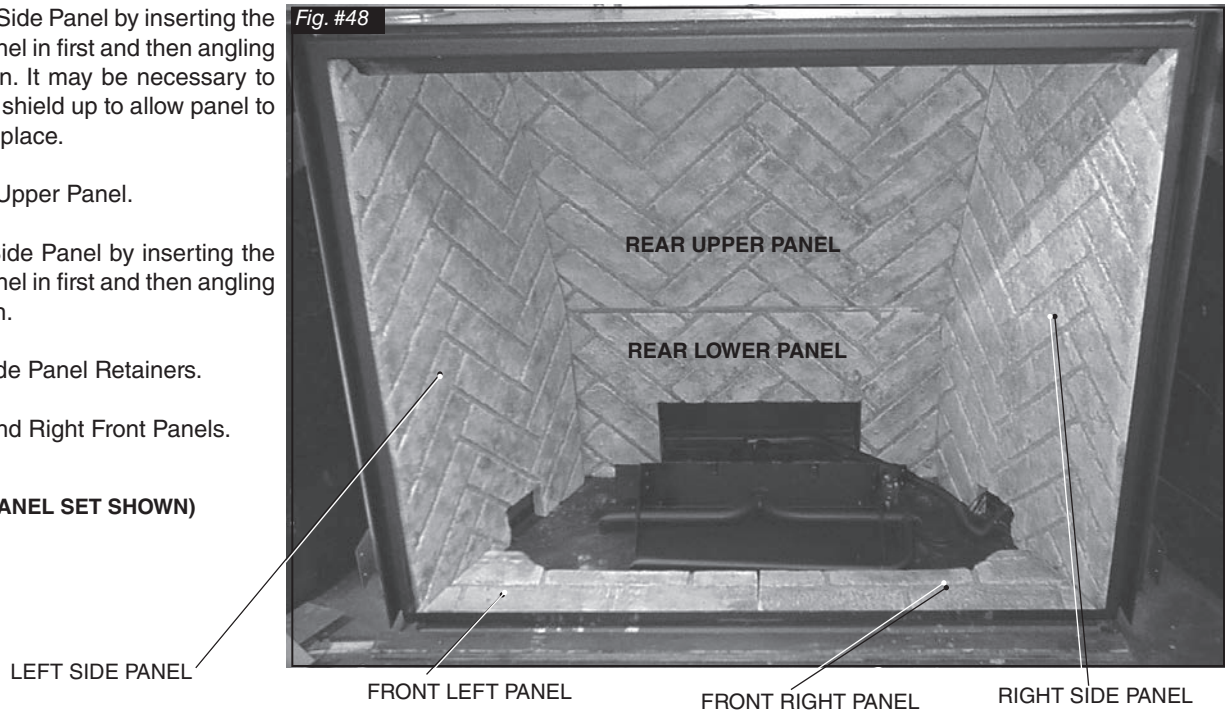

Lighting Instructions

FOR YOUR SAFETY READ BEFORE LIGHTING

WARNING: If you do not follow these instructions exactly, a fire or explosion may result causing property damage, personal injury or loss of life.

- A. This appliance is equipped with an ignition device which automatically lights the pilot. Do not try to light the pilot by hand.
B. **BEFORE LIGHTING** smell all around the appliance area for gas. Be sure to smell next to the floor because some gas is heavier than air and will settle on the floor.
WHAT TO DO IF YOU SMELL GAS:
- Do not try to light any appliance.

- Do not touch any electric switch; do not use any phone in your building.
- Immediately call your gas supplier from a neighbour's phone. Follow the gas supplier's instructions.
- If you cannot reach your gas supplier, call the fire department.
C. Use only your hand to push in or turn the gas control knob. Never use tools. If the knob will not push in or turn by hand, don't try to repair it, call a qualified service technician. Force or attempted repair may result in a fire or explosion.
D. Do not use this appliance if any part has been under water. Immediately call a qualified service technician to inspect the appliance & to replace any part of the control system & any gas control which has been under water.

LIGHTING INSTRUCTIONS

1. **STOP!** Read the safety information above on this label.
2. Set wall switch/ hand held remote to lowest setting.
3. This appliance is equipped with an ignition device which automatically lights the pilot. Do not try to light the pilot by hand.
4. Push the "On/ Off" switch to the fireplace Off.
5. Allow sufficient length of time (minimum 5 minutes) for any gas in the combustion chamber to escape. If you still smell gas, **STOP!** Follow "B" in the safety information above on this label. If you don't smell gas, go to the next step.
6. Push the "On/ Off" switch to turn the fireplace on.
- If the burner does not light, repeat steps 4 through 6.
- If the burner will not light or stay lit after several tries, push the "On/ Off" switch to the fireplace off and call your service technician or gas supplier.
Note: Sufficient time must be allowed for air to escape from lines if the unit is being lit for the first time.
7. Set fireplace to desired setting by using either the wall switch or hand held remote.

TO TURN OFF GAS TO APPLIANCE

1. Set wall switch / hand held remote to lowest setting.
2. Push the "on/ off" switch to the "Off" position.
3. Turn off all electric power to the appliance and remove backup batteries if service is to be performed or for extended shutdown.

Due to high surface temperatures, keep children, clothing and furniture away. Keep burner and control compartment clean. See installation and operating instructions accompanying the appliance.
A cause de la température élevée des parois, tenir éloignés les enfants, les vêtements et les meubles. Maintenir propres le brûleur et le compartiment de commande. Voir les instructions relatives à l'installation et au fonctionnement qui accompagnent l'appareil.

CAUTION: Hot while in operation. Do not touch. Severe burns may result. Keep children, clothing, furniture, gasoline and other liquids having flammable vapours away. Keep burner and control compartment clean. See installation and operating instructions accompanying the appliance.

ATTENTION: L'appareil est chaud lorsqu'il fonctionne. Ne pas toucher l'appareil. Risque de brûlures graves. Surveiller les enfants. Garder les vêtements, le meubles, l'essence ou autres liquides produisant des vapeurs inflammables loin de l'appareil. S'assurer que le brûleur et le compartiment des commandes sont propres. Voir les instructions d'installation et d'utilisation qui accompagnent l'appareil.

310106

5051.173

5-TC30

First Fire

When lit for the first time, the fireplace will emit a slight odour for a couple of hours. This is due to the curing of paints, sealants and lubricants used in the manufacturing process. This condition is temporary. Open doors and windows to ventilate area. Odour caused by the curing process may cause discomfort to some individuals.

It is normal for fireplaces fabricated of steel to give off some expansion and/or contraction noises during the start up or cool down cycle. Similar noises are found with your furnace heat exchanger or cook stove oven.

Maintenance

CAUTION:

Turn off gas and electrical power supply (if applicable) and allow ample time for unit to cool before servicing appliance. It is recommended that the fireplace and its venting should be inspected at least once a year by a qualified service person.

Glass Panel:

Warning: Do not operate fireplace with glass panel removed, cracked or broken. Replacement of the glass panel should be done by a licensed or qualified service person.

Do not strike or otherwise impact the glass in anyway that may cause it to break. If the glass becomes cracked or broken it must be replaced before using the fireplace. Replacement glass can be obtained from your nearest Town & Country Fireplaces™ dealer. The size required is 36" x 30" x 5mm. Use ceramic glass only. **Do not substitute with any other type.**

To remove broken glass, remove window frame as noted in "Window Frame Removal" section.

Unclip the Glass Retainer Clips located at the top and sides of the Window Frame. Pull the top edge of the glass out of the frame first, then lift it up and out of the bottom edge.

Install the new piece of glass with the gasket into the frame so that the thicker bead of gasket faces the fireplace.

Re-install glass retaining clips.

Annual Inspection:

- a) Remove glass panel and inspect the decorative burner media (such as logs, pebbles, glass etc) for soot build up. If excessive build up of soot is present, have a qualified service person inspect and adjust the unit for proper combustion. Clean the decorative media and use a brush or vacuum cleaner to clean the burner, paying close attention to the burner ports.
- b) Check the pilot system for proper flame size and operation. Clean pilot free of soot, dust or any other deposits. (See Fig. #49)
- c) Check that the vent pipe and vent terminal are open and free from blockage or debris. If the venting is disassembled for cleaning, it must be properly assembled and re-sealed. Refer to VENTING section for proper procedure.
- d) Check glass panel gasket, replace if necessary. It is important that the glass seal be maintained in good condition.
- e) Check and replace batteries as needed.

Note: The appliance area must be kept clear and free from combustible materials, gasoline and other flammable vapours and liquids.

Periodically:

- a) Viewing glass may be cleaned as necessary with fireplace glass cleaner.
- b) Exterior finish may be cleaned with mild soap and water.

CAUTION:

Do not use abrasive cleaners on glass or any other part of the fireplace.

Do not clean glass when hot.

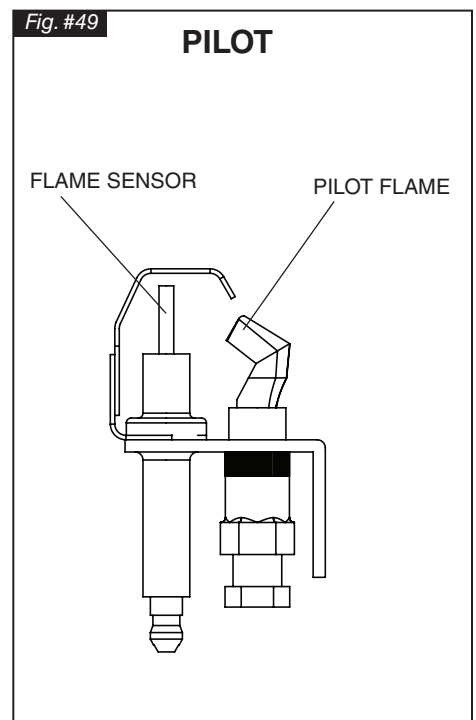

TC36.CODE Replacement Parts

(WHEN ORDERING, INCLUDE PART NUMBER WITH DESCRIPTION)

ITEM	DESCRIPTION	PART NO.	ITEM	DESCRIPTION	PART NO.
#1	TC36 OUTDOOR BODY ASSM.....	TC36.CODE	#4	PANEL SETS	
#2	GLASS ASSM.....	GLAS.2087ASSY		PARK AVE. BEIGE HERRINGBONE.....	TCPN.36PAC
#3	FRAMIMG KIT	TC36.BFRKITA		MT.VERNON RED HERRINGBONE	TCPN.36VRC
				MANHATTAN BEIGE STACKED BRICK.....	TCPN.36MNC
				BLACK PORCELAIN	TCPN.757031.C
				CB BROWN PORCELAIN	TCPN.757031CB.C
				COPPER PORCELAIN.....	TCPN.757031CU.C
				TITANIUM PORCELAIN	TCPN.757031TI.C

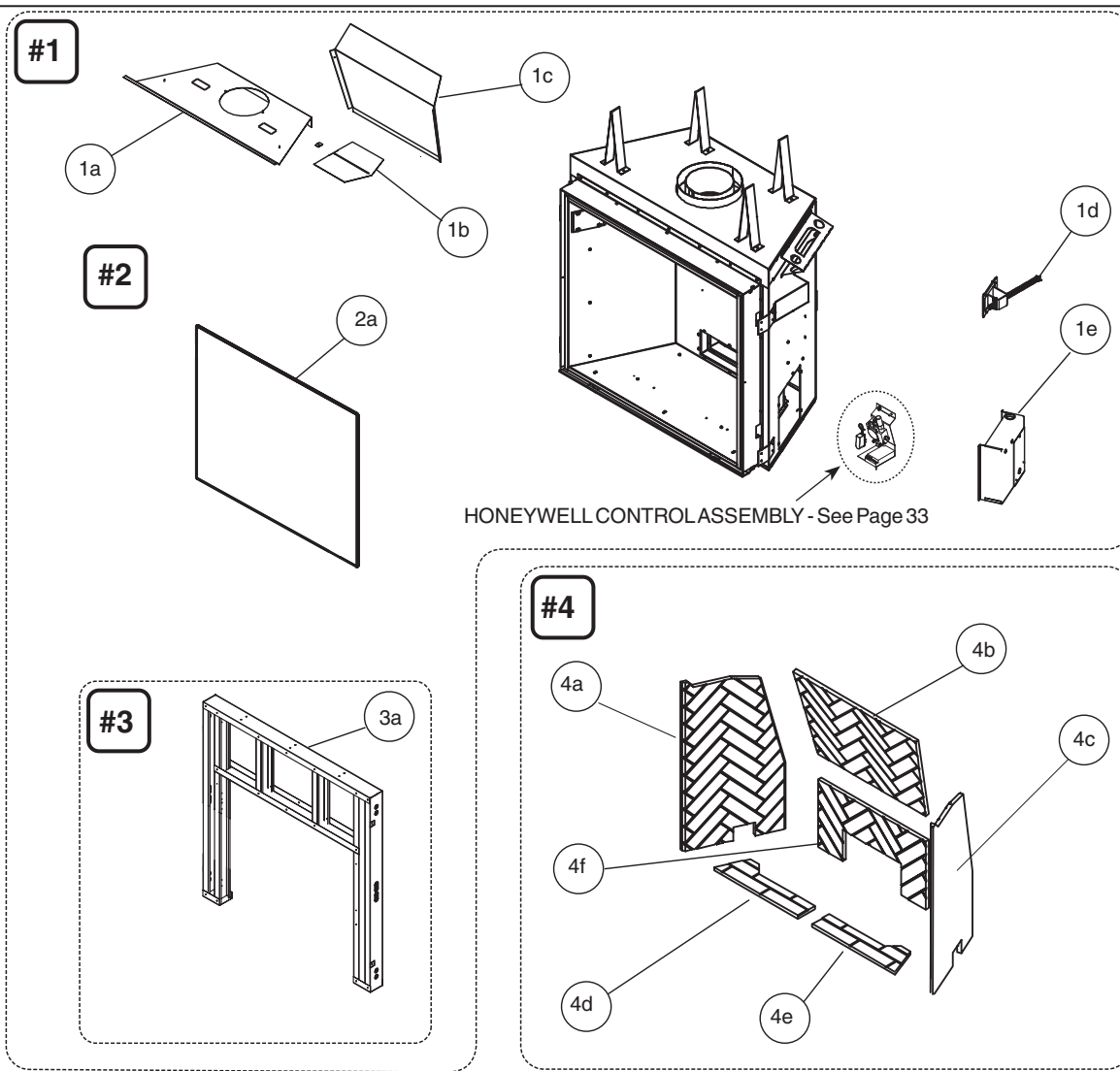

HONEYWELL CONTROL ASSEMBLY - See Page 33

KIT CONTENTS:

#1.....TC36 BODY ASSEMBLY

- 1a FIREBOX SHIELD (c/w insulation)
- 1b FLUE DAMPER
- 1c FIREBOX REAR SHIELD
- 1d SPRING LATCH ASSEMBLY(2)
- 1e CONTROL ASSEMBLY HOLDER
- BRICK PANEL RETAINER (not shown)

#2.....GLASS ASSEMBLY

- 2a REPLACEMENT GLASS (c/w gasket)

#3.....FRAMIMG KIT

- 3a STEEL STUDS

#4.....PANEL SETS

- 4a PANEL, LEFT SIDE
- 4b PANEL, UPPER
- 4c PANEL, RIGHT SIDE
- 4d PANEL, LEFT BASE
- 4e PANEL, RIGHT BASE
- 4f PANEL, LOWER BACK

Replacement Parts – Honeywell Control System

(WHEN ORDERING, INCLUDE PART NUMBER WITH DESCRIPTION)

ITEM.....	DESCRIPTION.....	PART NO.
#1.....	CONTROL ASSEMBLY KIT	TCRP.9000
#2.....	BULKHEAD ASSEMBLY KIT	TCRP.8133
#3.....	CONTROL BOX KIT	TCRP.92762WLD
#4.....	TEST FITTING	5019.104

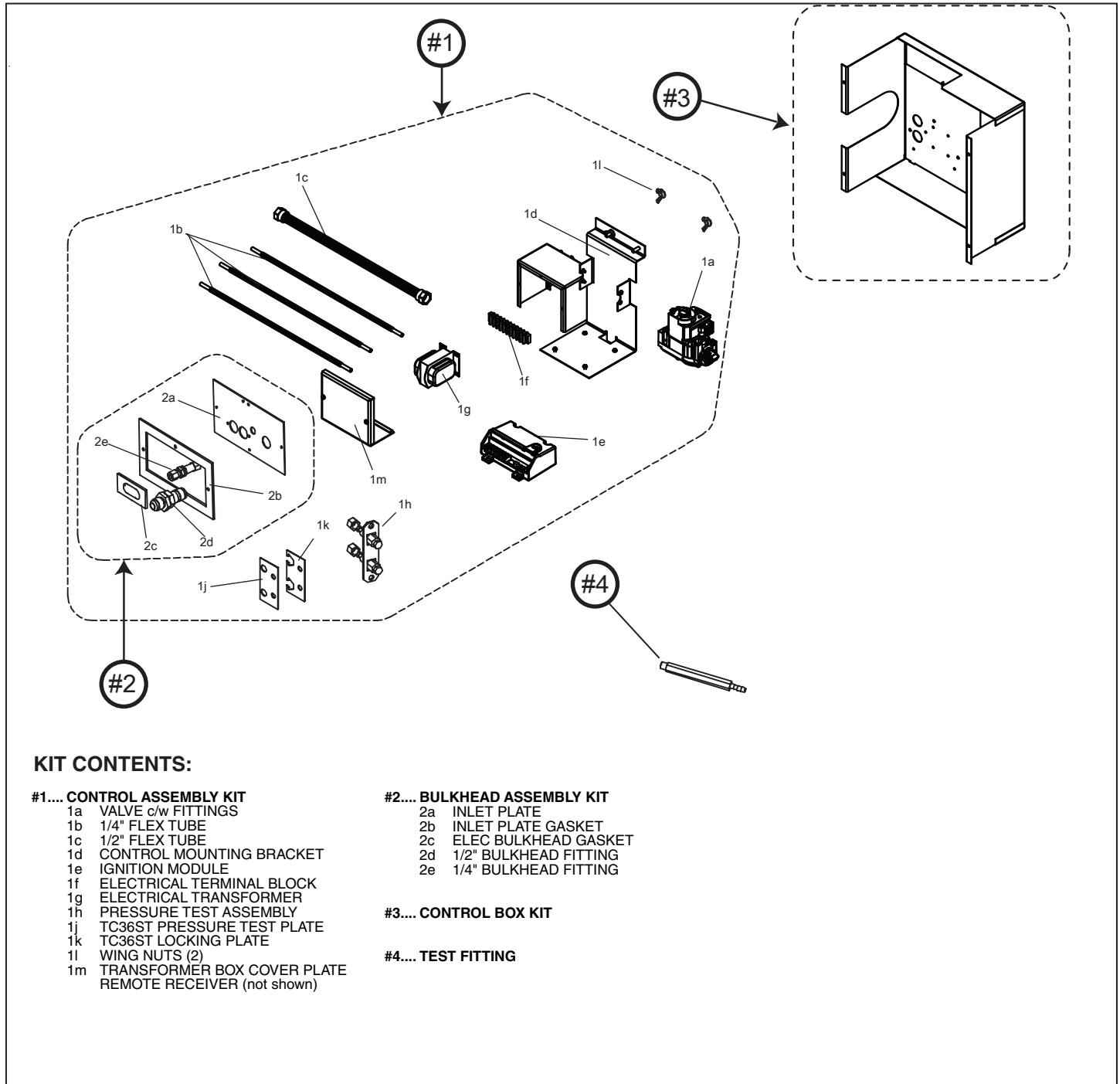

KIT CONTENTS:

#1.... CONTROL ASSEMBLY KIT

- 1a VALVE c/w FITTINGS
- 1b 1/4" FLEX TUBE
- 1c 1/2" FLEX TUBE
- 1d CONTROL MOUNTING BRACKET
- 1e IGNITION MODULE
- 1f ELECTRICAL TERMINAL BLOCK
- 1g ELECTRICAL TRANSFORMER
- 1h PRESSURE TEST ASSEMBLY
- 1j TC36ST PRESSURE TEST PLATE
- 1k TC36ST LOCKING PLATE
- 1l WING NUTS (2)
- 1m TRANSFORMER BOX COVER PLATE

#2.... BULKHEAD ASSEMBLY KIT

- 2a INLET PLATE
- 2b INLET PLATE GASKET
- 2c ELEC BULKHEAD GASKET
- 2d 1/2" BULKHEAD FITTING
- 2e 1/4" BULKHEAD FITTING

#3.... CONTROL BOX KIT

#4.... TEST FITTING

Wiring Diagram

Fig. #50

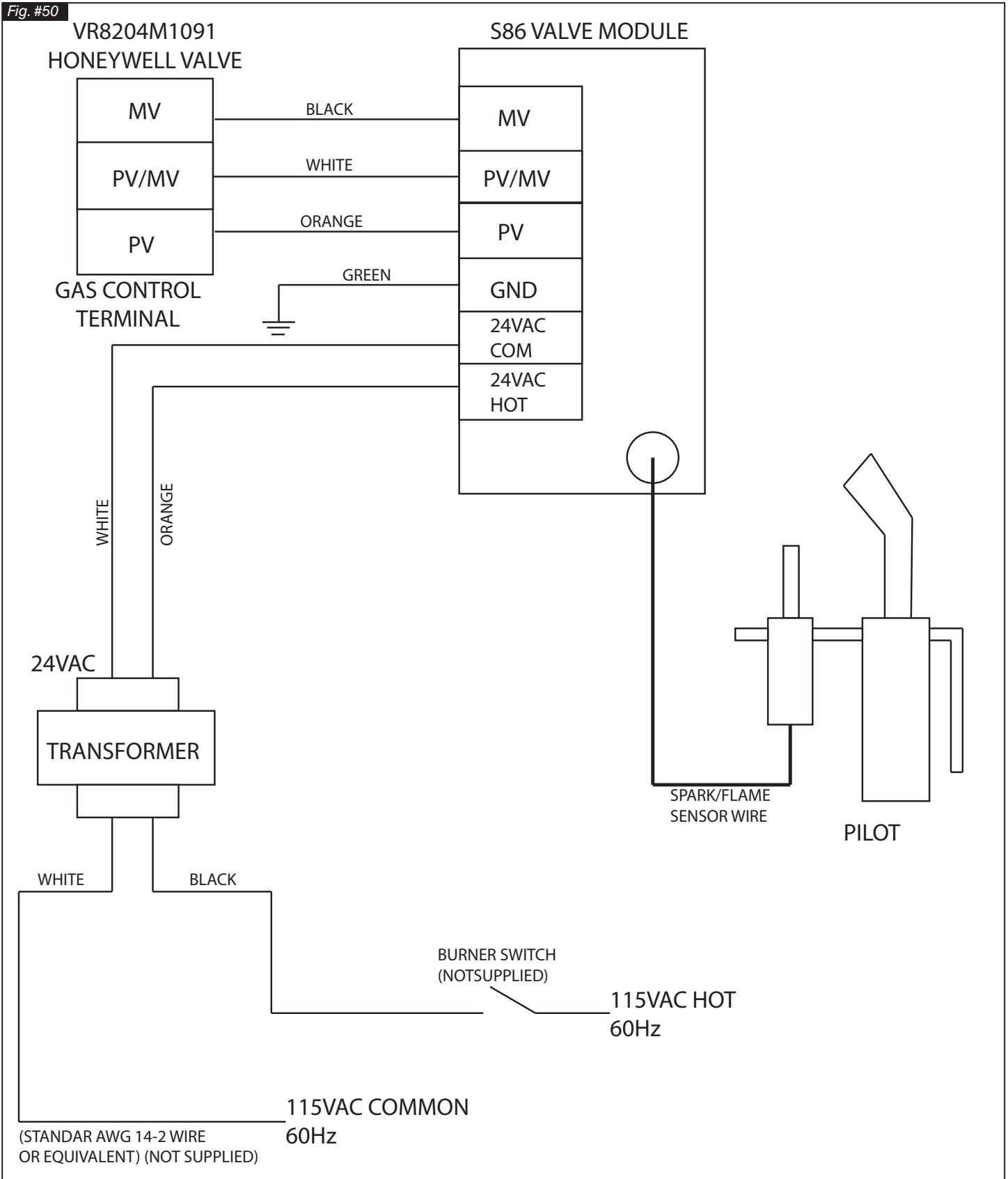

Wall Termination Kit

TCVT.WTA

Wall Shield/ Ceiling Firestop Thimble TCVT.THIMA

Fig. #53

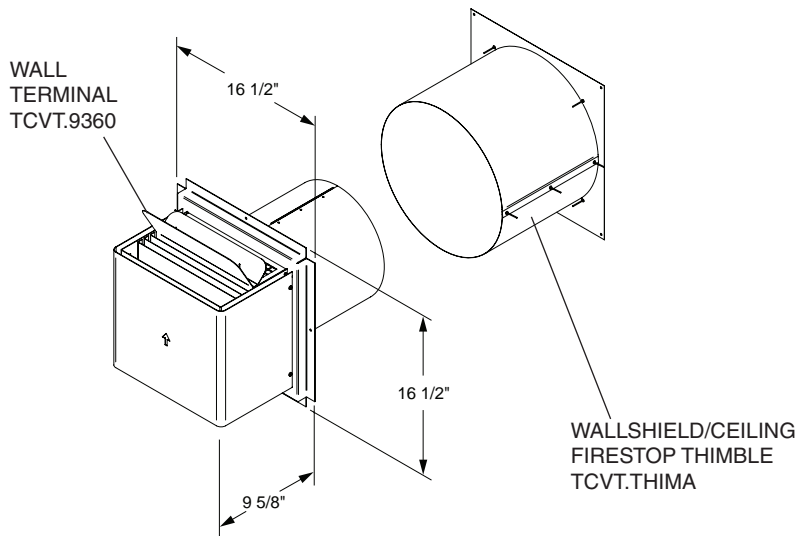
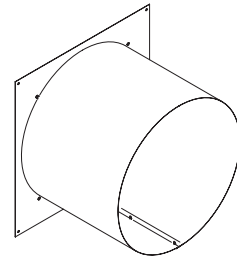

Fig. #54



Roof Termination Kit

TCVT.RTA

Fig. #55

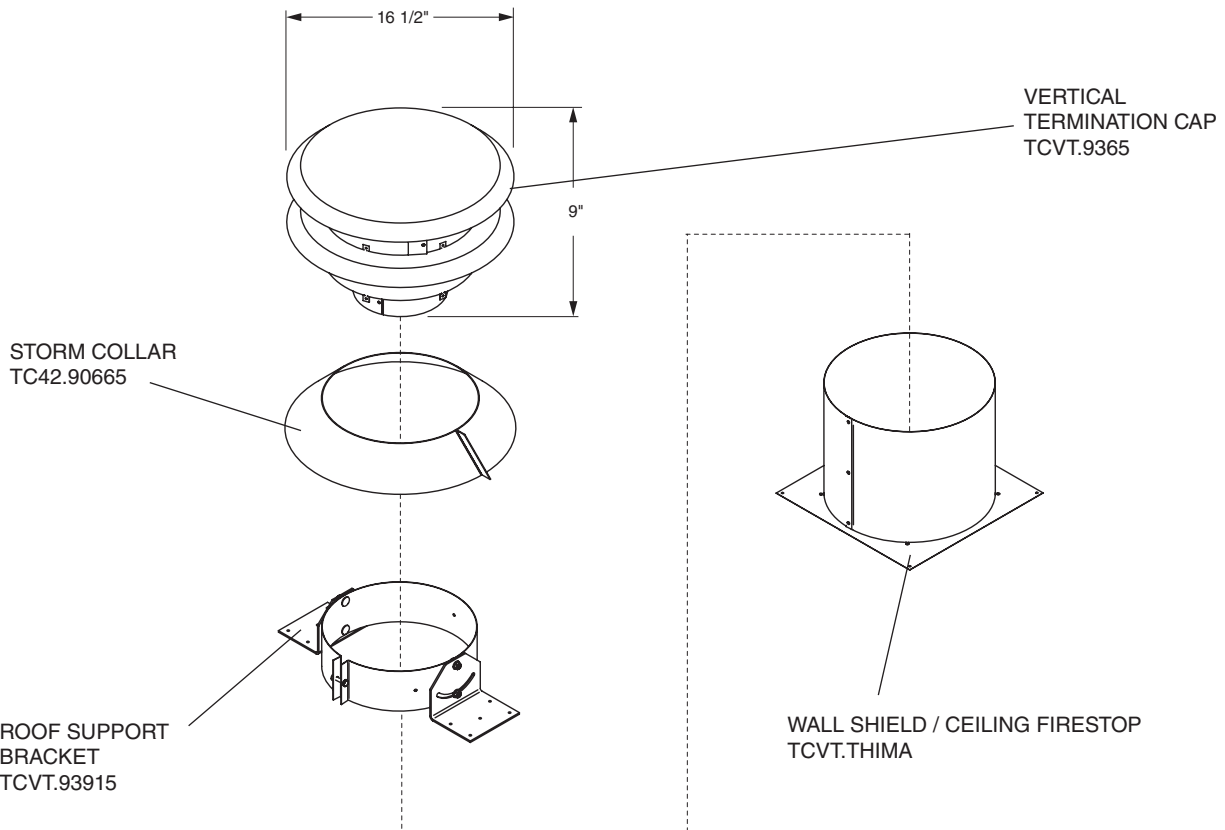

Vent Pipe Dimensions

Fig. #56

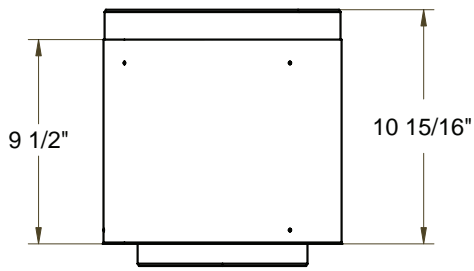

TCVT.811X12ADJ

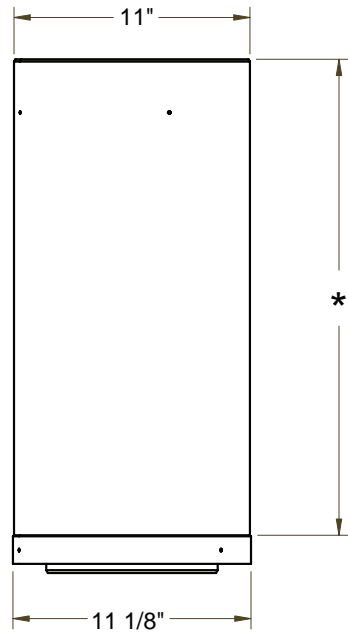

TCVT.811X __

- 12" PIPE 10 1/4"
- 18" PIPE 16 1/4"
- 24" PIPE 22 1/4"
- 48" PIPE 46 1/4"

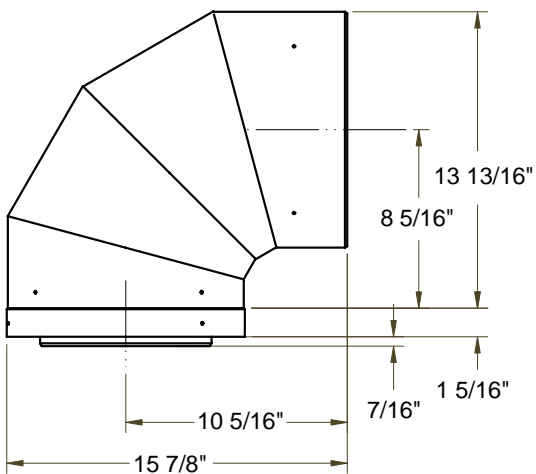

TCVT.811XLB90

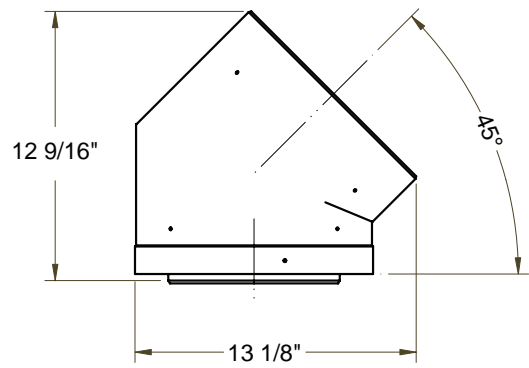

TCVT.811XLB45

Vent Offset Chart

Fig. #57

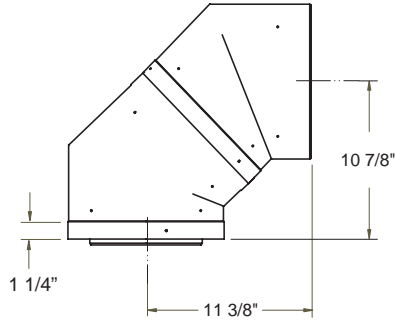

A	B	C
12" PIPE	18 5/8"	18"
18" PIPE	22 7/8"	22 3/8"
24" PIPE	27 1/8"	26 1/2"
48" PIPE	44 1/16"	43 1/2"

ADDING AN ADJUSTABLE SECTION TO PIPE WILL INCREASE OFFSET BY 2 1/8" TO 6 3/4"

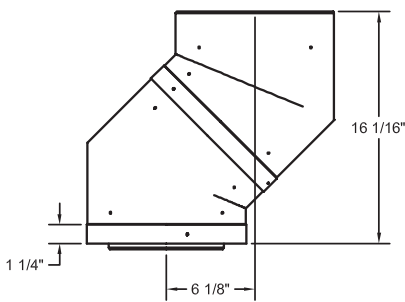
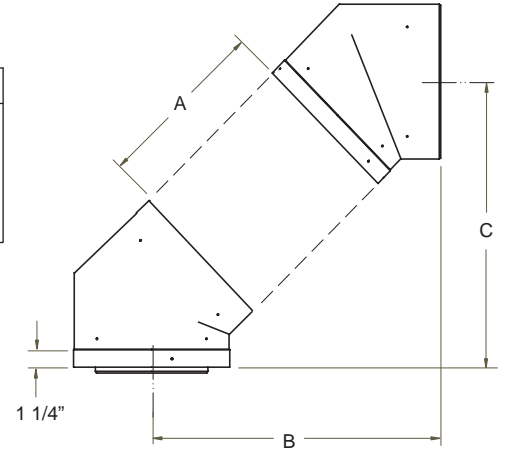

A	B	C
12" PIPE	13 7/16"	23 1/4"
18" PIPE	17 9/16"	27 5/8"
24" PIPE	21 7/8"	31 3/4"
48" PIPE	38 3/4"	44 7/8"

ADDING AN ADJUSTABLE SECTION TO PIPE WILL INCREASE OFFSET BY 2 1/8" TO 6 3/4"

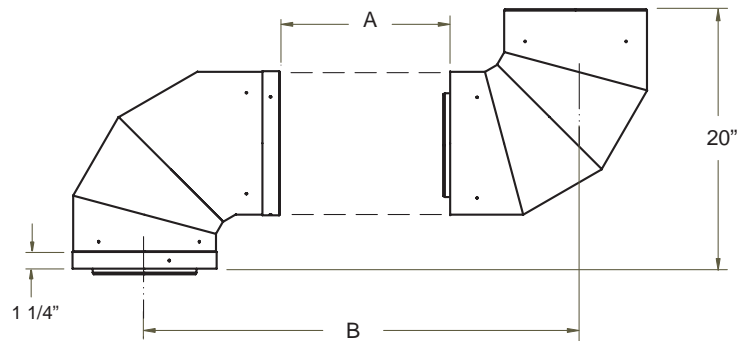
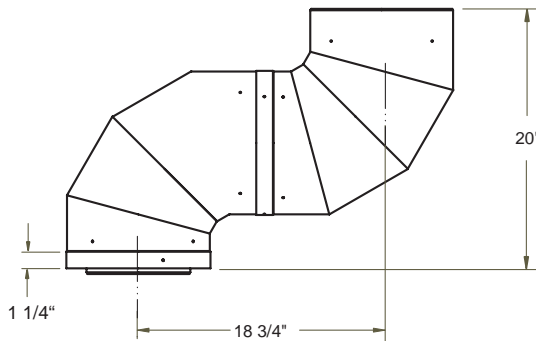
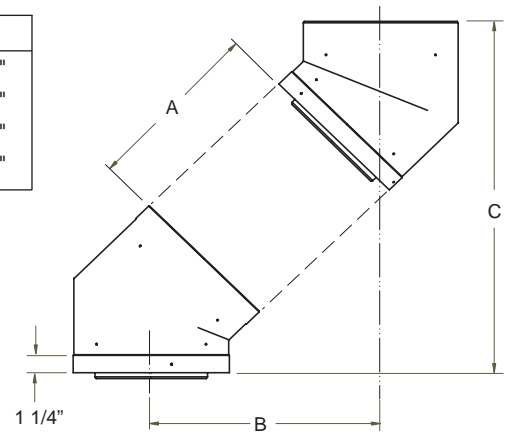

A	B
12" PIPE	29"
18" PIPE	35"
24" PIPE	41"
48" PIPE	65"

ADDING AN ADJUSTABLE SECTION TO PIPE WILL INCREASE OFFSET BY 3" TO 9 1/2"

Safety Label Location

NOTE: The Safety Label is located on a plate found in a slot between the left hand side lintel and the left hand side window frame. This plate is attached to the lintel with a cable.



TOWN & COUNTRY
FIREPLACES™

MODEL/
MODELE:
TC36.CODE

SERIES/
SERIE: **A**

MADE IN CANADA
FABRIQUE AU CANADA

VENTED OUTDOOR GAS FIREPLACE - NOT FOR USE WITH SOLID FUEL, FOYER AU GAZ À ÉVACUATION - NE PAS UTILISER AVEC DU COMBUSTIBLE SOLIDE

ANSI Z21.97-2012 Outdoor Decorative Gas Fireplaces
CSA 2.41-2012 Outdoor Gas Fireplaces

Certified for / Certifié pour Canada and U.S.A.

This Appliance is Equipped For Use With /
Cet Appareil est Équipé Pour Utilisé Avec :

NATURAL GAS LP-GAS
GAZ NATUREL LP GAZ

FOR USE WITH/ EN CASE D'EMPLOI AVEC:	NATURAL GAS/ DU GAZ NATUREL	LP GAS/ DU GAZ LP
Minimum supply pressure / Pression minimum d'alimentation: (For the purpose of input adjustment / dans le but de régler l'alimentation)	5.0 in/wc / 5.0 po/c.e. (1.25 kPa)	12.5 in/wc / 12.5 po/c.e. (3.11 kPa)
Maximum supply pressure / Pression maximum d'alimentation:	13.9 in/wc / 13.9 po/c.e. (3.45 kPa)	13.9 in/wc / 13.9 po/c.e. (3.45 kPa)
Manifold pressure / Pression de la tuyauterie: Maximum	3.8 in/wc / 3.8 po/c.e. (.95 kPa)	11.0 in/wc / 11.0 po/c.e. (2.74 kPa)
Orifice Size / Diametre de l'injecteur:	#30 (3.26 mm)	#45 (2.08 mm)
Input BTU/hr (kW) / Entree BTU/h (kW):	Max.: 47,000 (13.8) Min.: 35,000 (10.3)	Max.: 47,900 (13.8) Min.: 35,000 (10.3)

FOR OUTDOOR USE ONLY / POUR USAGE EXTÉRIEUR SEULEMENT

Electrical rating: 115v, 60hz, 1.5 A / Note électrique: 115v, 60hz, 1.5 A. This appliance equipped for altitudes 0 - 4500 ft. (0 - 1372 m) / Cet unité est conçu pour des altitudes variant entre 0 - 4500 pieds (0 - 1372 m). This appliance must be installed in accordance with local codes, if any; if none, follow the current CAN/CGA-B149 (Canada), or ANSI Z223.1 (USA) Installation Codes. Installer l'appareil selon les codes ou règlements locaux, ou, en l'absence de tels règlements, selon les codes d'installation CAN/CGA-B149 (Canada), or ANSI Z223.1 (USA) en vigueur. The appliance, when installed, must be electrically grounded in accordance with local codes or, in the absence of local codes, with the Canadian Electrical Code, CSA C22.1 or with the National Electrical Code, ANSI/NFPA 70. L'appareil, une fois installé, doit être connecté électriquement à la terre conformément aux codes locaux ou, en l'absence de codes locaux, avec le Code canadien de l'électricité,CSAC22.1 ou avec le National Electrical Code,ANSI /NFPA70.

WARNING: Do not store or use gasoline or other flammable vapors or liquids in the vicinity of this or any other appliance. An LP cylinder not connected for use shall not be stored in the vicinity of this or any other appliance.

AVERTISSEMENT : Ne stockez pas ou utilisez l'essence ou d'autres vapeurs inflammables ou des liquides aux alentours de ceci ou un autre appareil. Un cylindre LP non connecté pour l'utilisation ne sera pas stocké aux alentours de ceci ou un autre appareil.

FOR USE WITH GLASS DOORS CERTIFIED WITH THE APPLIANCE ONLY / POUR UTILISATION UNIQUEMENT AVEC LES PORTES IN VERRE CERTIFIÉES AVEC L'APPAREIL

MINIMUM CLEARANCES TO COMBUSTIBLES / CLAIRANCES MINIMALES AVEC LES COMBUSTIBLE
Left and Right side are determined when facing the front of the appliance. / Les côtés droit et gauche se déterminent en se mettant devant l'appareil et en lui faisant face.

Top, Back and Side Standoffs / Sommet, Arrière et Côté Butée	0 in./ 0 po.	(0 mm)
Sidewall to Appliance / Du mur latéral a l'appareil	4 in./ 4 po.	(102 mm)
Ceiling to Appliance / Plafond a l'appareil	24 in./ 24 po.	(610 mm)
Mantel to Appliance / Du manteau al'appareil	*9 in./ 9 po.	(229 mm)
Maximum Mantel Extension / Allongement maximum du manteau	*12 in./ 12 po.	(305 mm)
*See Installation Manual for more detail / Voyez des Directive de l'Installation pour plus détails.		
Mantel Supports / Supports du manteau	4 in./ 4 po.	(102 mm)
Vent Pipe / Déchargez le Tuyau	1.75 in./ 1.75 po.	(45 mm)

WARNING: Improper installation, adjustment, alteration, service or maintenance can cause injury or property damage. Refer to the owner's information manual provided with this appliance. For assistance or additional information, consult a qualified installer, service agency or the gas supplier.

AVERTISSEMENT: Une installation, un réglage, une modification, une réparation ou un entretien mal effectué peut causer des dommages matériels ou des blessures. Voir la notice de l'utilisateur qui accompagne l'appareil. Pour de l'aide ou des renseignements supplémentaires, consultez un installateur, un technicien agréé ou le fournisseur de gaz.

103013

5050.3601

1-TC36.CODE

Pacific Energy
Fireplace Products Ltd.
Duncan, British Columbia,
Canada

Jan.	Feb.	Mar.	Apr.	May	June
July	Aug.	Sept.	Oct.	Nov.	Dec.
2013	2014	2015	2016	2017	2018

© 2015 Copyright Pacific Energy Fireplace Products LTD

Reproduction, adaptation, or translation
without prior written permission is prohibited,
except as allowed under the copyright laws.



For technical support, please contact your retailer.

**Web site: www.townandcountryfireplaces.net
2975 Allenby Rd., Duncan, BC V9L 6V8**