

CARLTON 39

Model #CAR-39 Direct Vent Gas Fireplace

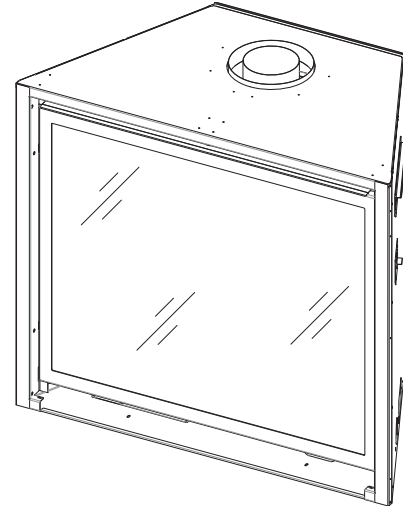

English and French installation manuals are available through your local dealer. Visit our website www.kozyheat.com.

Les manuels d'installation en français et en anglais sont disponibles chez votre détaillant local. Visitez www.kozyheat.com.



▲ WARNING:
FIRE OR EXPLOSION HAZARD
Failure to follow safety warnings exactly could result in serious injury, death, or property damage.

- Do not store or use gasoline or other flammable vapors and liquids in the vicinity of this or any other appliance.
- **WHAT TO DO IF YOU SMELL GAS**
 - Do not try to light any appliance.
 - Do not touch any electrical switch; do not use any phone in your building.
 - Leave the building immediately.
 - Immediately call your gas supplier from a neighbor's phone. Follow the gas supplier's instructions.
 - If you cannot reach your gas supplier, call the fire department.
- Installation and service must be performed by a qualified installer, service agency or the gas supplier.

This appliance may be installed in an aftermarket, permanently located, manufactured home (USA only) or mobile home, where not prohibited by local codes.

This appliance is only for use with the type of gas indicated on the rating plate. This appliance is not convertible for use with other gases, unless a certified kit is used.

! DANGER



**HOT GLASS WILL
CAUSE BURNS**
**DO NOT TOUCH GLASS
UNTIL COOLED**
**NEVER ALLOW CHILDREN
TO TOUCH GLASS**

A barrier designed to reduce the risk of burns from the hot viewing glass is provided with this appliance and shall be installed for the protection of children and other at-risk individuals.

INSTALLER: Leave this manual with the appliance.
CONSUMER: Retain this manual for future reference.

Read this manual before installation or operating this appliance.
Please retain this owner's manual for future reference.

CONGRATULATIONS!

We welcome you as a new owner of a Kozy Heat gas fireplace. Kozy Heat products are designed with superior components and materials, and assembled by trained craftsmen who take pride in their work. To ensure you receive a quality product, the burner and valve assembly are 100 percent test-fired, and the complete fireplace is thoroughly inspected before packaging. Our commitment to quality and customer satisfaction has remained the same for over 40 years. We offer a complete line of gas and wood fireplaces, along with stylish accessories to complement any decor. Adding a fireplace is one of the best ways to increase the value of your home, and we are proud to offer a network of dealers throughout the country to help make your experience everything you imagine. We pride ourselves in being dedicated not only to functionality and reliability, but also customer safety. We offer our continual support and guidance to help you achieve the maximum benefit and enjoyment from your Kozy Heat gas fireplace.

Jim Hussong
President



Dudley Hussong
Board Chairman



Homeowner Reference Information

We recommend you record the following information:

Model Name: _____ Date purchased/installed: _____

Serial Number: _____ Location of fireplace: _____

Dealership Purchased from: _____ Dealer phone: _____

Notes: _____

TABLE OF CONTENTS

TABLE OF CONTENTS	5	7.5 Rigid Pipe Vent Installation.....	29
1.0 INTRODUCTION	7	7.6 #800-1 Series Direct Vent Termination Kit(s) Installation.....	32
1.1 Appliance Certification	7	7.7 Vent Heat Shield Assembly Installation	34
1.2 California Proposition 65 Warning.....	7	8.0 FIREPLACE SETUP	35
1.3 Requirements for the Commonwealth of Massachusetts.....	7	8.1 Glass Frame Assembly.....	35
2.0 SPECIFICATIONS	8	8.2 Light Kit	35
2.1 Heating Specifications	8	8.3 #C39-50B Log Set Installation	36
2.2 Electrical Specifications	8	8.4 Control Board Removal and Installation.....	37
2.3 Appliance Dimensions	9	9.0 ELECTRICAL INFORMATION	38
2.4 Barrier Dimensions	10	9.1 Electrical Specifications	38
3.0 FRAMING	11	9.2 Wiring Requirements.....	38
3.1 Appliance Placement Considerations	11	10.0 OPERATING INSTRUCTIONS	39
3.2 Stand-off Assembly and Installation.....	11	10.1 Setup Proflame 2 IFC Module	40
3.3 Nailing Flange Assembly and Installation.....	12	10.2 Initialize the Control System.....	40
3.4 Clearances to Combustibles	13	10.3 Reset the System for Manual Operation	40
3.5 Rough Framing	14	10.4 Automatic Safety Restart.....	40
3.6 Vent Termination Rough Framing.....	15	10.5 Backup Battery Operation	40
3.7 Outdoor Covered Fireplace Installation.....	16	10.6 Control System 7 Day Timeout	40
4.0 FACING AND FINISHING	18	10.7 IFC Module Ignition Sequence	41
4.1 Facing and Finishing Requirements	18	10.8 Additional Diagnostic Information	41
4.2 Optional Finishing Trim Kit (FTK): #C39-FTK.....	21	10.9 Remote Control Operation	42
4.3 Safety Barrier Installation	22	11.0 ADJUSTMENT	45
5.0 GAS LINE CONNECTION	25	11.1 Pressure Testing	45
5.1 Gas Conversion (sold separately)	25	11.2 Burner Flame Adjustments	46
5.2 Gas Line Installation.....	25	12.0 TROUBLESHOOTING	48
6.0 TERMINATION LOCATIONS	26	13.0 MAINTENANCE	50
6.1 Vertical Vent Termination	26	13.1 Firebox.....	50
6.2 Minimum Vent Termination Clearances.....	27	13.2 Fan	50
7.0 VENTING	28	13.3 Vent System.....	50
7.1 Approved Vent Systems.....	28	13.4 Glass Assembly.....	50
7.2 Venting Requirements	28	13.5 Burner and Pilot System	51
7.3 Use of Elbows	28	14.0 REPLACEMENT PARTS LIST	52
7.4 Vent Restriction	28	LIMITED LIFETIME WARRANTY	53

1.0 INTRODUCTION

1.1 Appliance Certification

Laboratory: PFS in Cottage Grove, Wisconsin

Standards:

ANSI Z21.88-2017/CSA 2.33-2017, Vented Gas Fireplace Heaters

CSA 2.17 2017, Gas-Fired Appliances for Use at High Altitudes

This installation must conform with local codes, or in the absence of local codes, with the National Fuel Gas Code, ANSI Z223.1/NFPA 54, or the Natural Gas and Propane Installation Code, CSA B149.1.

1.2 California Proposition 65 Warning

 **WARNING:** This product can expose you to chemicals including Carbon Monoxide, that is an externally vented by-product of fuel combustion, which is [are] known to the State of California to cause cancer, birth defects or other reproductive harm. For more information, visit www.P65Warnings.ca.gov.

1.3 Requirements for the Commonwealth of Massachusetts

The following requirements reference various Massachusetts and national codes not contained in this manual.

For all sidewall horizontally vented gas fueled equipment installed in every dwelling, building or structure used in whole or in part for residential purposes, including those owned or operated by the Commonwealth and where the side wall exhaust vent termination is less than (7) feet above finished grade in the area of the venting, including but not limited to decks and porches, the following requirements shall be satisfied:

1.3.1 Installation of Carbon Monoxide Detectors

At time of installation of side wall horizontally vented gas fueled equipment, the installing plumber or gas-fitter shall observe that a hard wired carbon monoxide detector with an alarm and battery back-up is installed on the floor level where the gas equipment is to be installed. In addition, the installing plumber or gas-fitter shall observe that a battery operated or hard wired carbon monoxide detector is installed on each additional level of the dwelling, building or structure served by the side wall horizontal vented gas fueled equipment. It shall be the responsibility of the property owner to secure the services of qualified licensed professionals for the installation of hard wired carbon monoxide detectors.

In the event that the side wall horizontally vented gas fueled equipment is installed in a crawl space or attic, the hard wired carbon monoxide detector with alarm and battery back-up may be installed on the next adjacent floor level. In the event that the requirements of this subdivision can not be met at the time of completion of installation, the owner shall have a period of thirty (30) days to comply with the above requirements; provided, however, that during said thirty (30) day period, a battery operated carbon monoxide detector with an alarm shall be installed.

1.3.2 Approved Carbon Monoxide Detectors

Each carbon monoxide detector as required in accordance with the above provisions shall comply with NFPA 720 and be ANSI/UL 2034 listed and IAS certified.

1.3.3 Signage

A metal or plastic identification plate shall be permanently mounted to the exterior of the building at a minimum of eight (8) feet above grade directly in line with the exhaust vent terminal for the horizontally vented gas fueled heating appliance or equipment. The sign shall read, in print no less the one-half inch (½) in size, "GAS VENT DIRECTLY BELOW. KEEP CLEAR OF ALL OBSTRUCTIONS".

1.3.4 Inspection

The state or local gas inspector of the side wall horizontally vented gas fueled equipment shall not approve the installation unless, upon inspection, the inspector observes carbon monoxide detectors and signage installed in accordance with the provisions of 248 CMR 5.08 (2) (a) 1 through 4.

1.3.5 Exemptions

The following equipment is exempt from 248 CMR 5.08 (2) (a) 1 through 4: The equipment listed in Chapter 10 entitled "Equipment Not Required To Be Vented" in the most current edition of NFPA 54 as adopted by the Board; and Product Approved side wall horizontally vented gas fueled equipment installed in a room or structure separate from the dwelling, building or structure used in whole or in part for residential purposes.

1.3.6 Manufacturer Requirements

1.3.6.1 Gas Equipment Venting System Provided

When the manufacturer of Product Approved side wall horizontally vented gas equipment provides a venting system design or venting system components with the equipment, the instructions provided by the manufacturer for installation of the equipment and the venting system shall include:

- Detailed instructions for the installation of the venting system design or the venting system components; and
- A complete parts list for the venting system design or venting system.

1.3.7 Gas Equipment Venting System NOT Provided

When the manufacturer of Product Approved side wall horizontally vented gas equipment does not provide the parts for venting the flue gases, but identifies "special venting systems", the following requirements shall be satisfied by the manufacturer:

- The referenced "special venting systems" instructions shall be included with the appliance or equipment installation instructions and;
- The "special venting systems" shall be Product Approved by the Board, and the instructions for that system shall include a parts list and detailed installation instructions.

A copy of all installation instructions for all Product Approved side wall horizontally vented gas fueled equipment, all venting instructions, all parts lists for venting instructions, and/or all venting design instructions shall remain with the appliance or equipment at the completion of the installation.

2.0 SPECIFICATIONS

2.1 Heating Specifications

	Natural Gas	Propane
Maximum Input Rating	40,000 Btu/h (11.7 kW)	41,000 Btu/h (12.0 kW)
Minimum Input Rating	13,000 Btu/h (3.8 kW)	13,500 Btu/h (4.0 kW)
Manifold Pressure (High)	3.8" WC (0.95 kPa)	11" WC (2.74 kPa)
Manifold Pressure (Low)	1.1" WC (0.27 kPa)	2.9" WC (0.72 kPa)
Orifice Size (DMS)	FRONT: #44 BACK: #47	FRONT: #55 BACK: #56

2.1.1 Altitude Adjustment

This appliance may be installed at higher altitudes. Please refer to National Fuel Gas Code ANSI Z223.1/NFPA 54, CSA-B149.1 Natural Gas and Propane Installation Code, local authorities, or codes having jurisdiction in your area regarding derate guidelines.

2.1.1.1 US Installations

Refer to the American Gas Association guidelines for the gas designed appliances derating method. For elevations above 2,000' (610 m), input ratings are to be reduced by 4% for each 1,000' (305 m) above sea level.

2.1.1.2 Canadian Installations

When the appliance is installed at elevations above 4,500' (1,372 m), the certified high altitude rating shall be reduced at the rate of 4% for each additional 1,000' (305 m).

2.2 Electrical Specifications

- The junction box in this appliance requires 120VAC, 60Hz, and 6 Amps.
- Verify the household breaker is shut off prior to working on any electrical lines.
- The AC power supply to this appliance must be hot at all times and shall not have a switch installed in it.

2.3 Appliance Dimensions

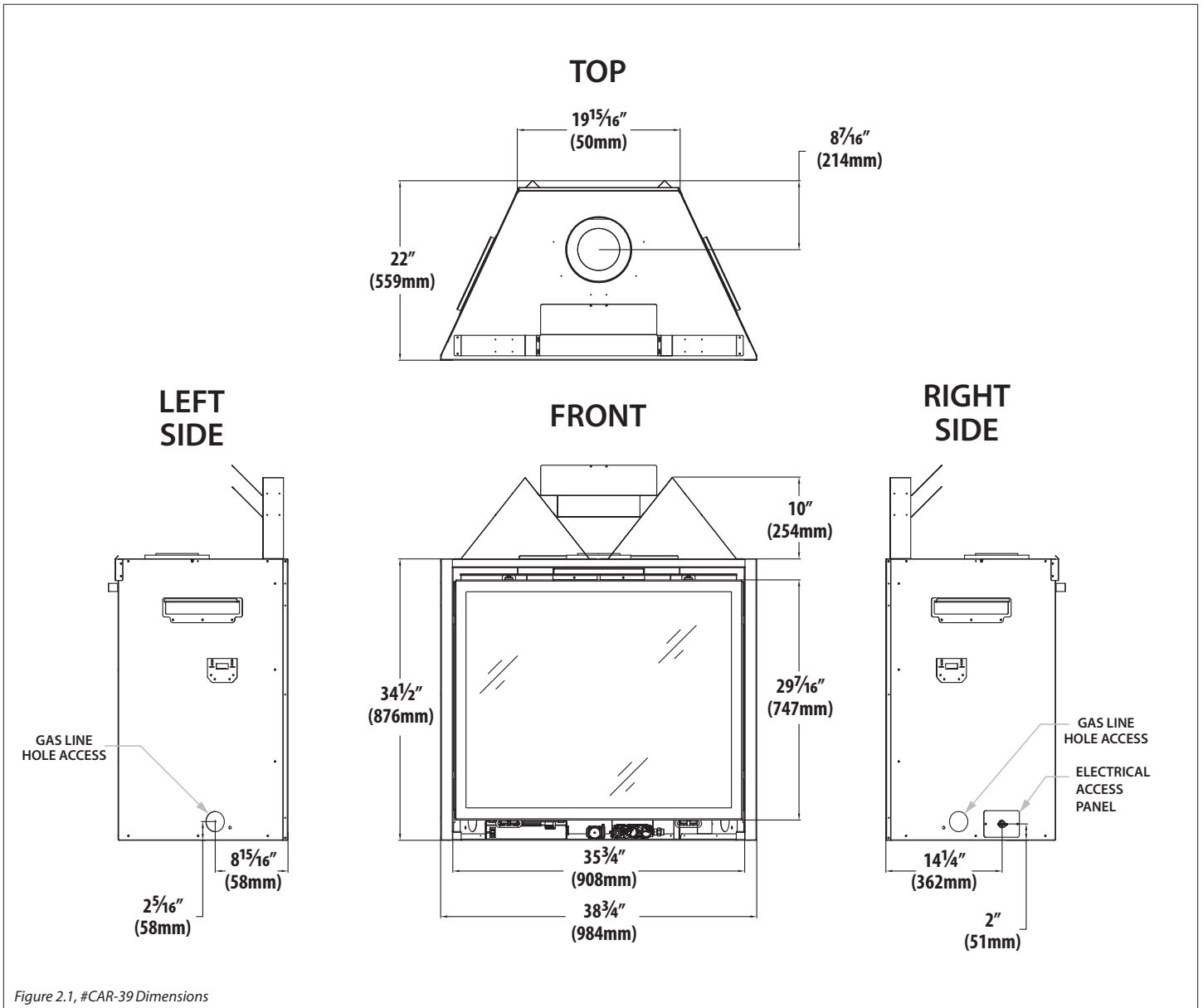

2.4 Barrier Dimensions

WARNING: A barrier designed to reduce the risk of burns from the hot viewing glass is provided with this appliance and shall be installed for the protection of children and other at-risk individuals.

If the barrier becomes damaged, the barrier shall be replaced with Hussong Mfg.'s barriers for this appliance.

IMPORTANT: Consider the height of hearth finish material when building a fireplace platform. Use the drawing below for overlap dimensions to ensure the barrier can fit with finishing materials.

For installation instructions, refer to Section 4.3 Safety Barrier Installation on page 22.

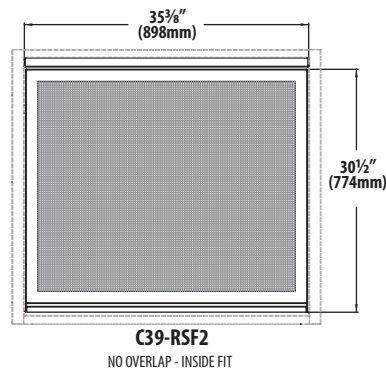
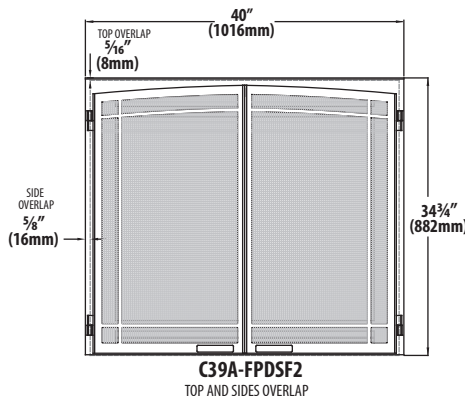
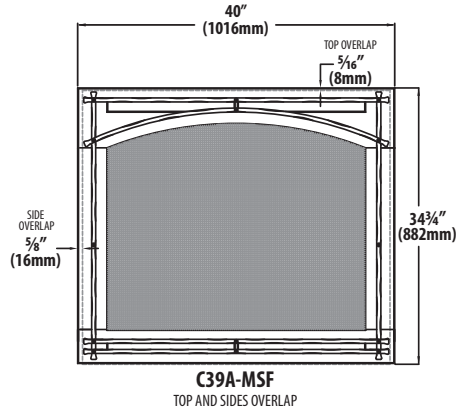
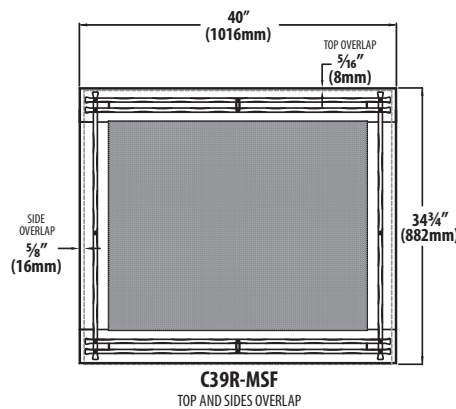
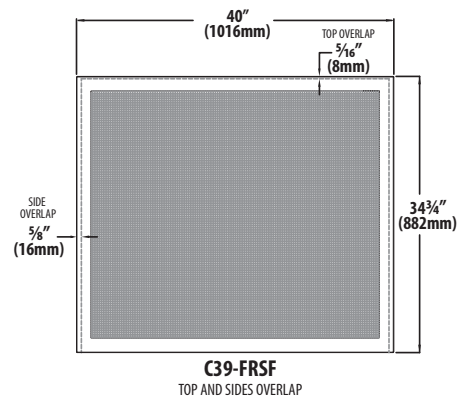
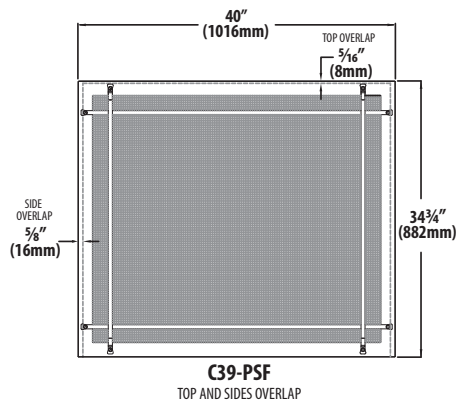

3.0 FRAMING

3.1 Appliance Placement Considerations

WARNING: Due to high temperatures, the appliance should be located out of traffic and away from furniture and draperies.

- This appliance must be installed on a level surface capable of supporting the fireplace and venting. Determine your vent requirements before framing your appliance. If possible, place the fireplace in a position where the vent terminates between two studs, eliminating the need for any additional framing.
- This fireplace may be installed in a bedroom.
- Please be aware of the large amount of heat this fireplace will produce when determining a location.

3.2 Stand-off Assembly and Installation

WARNING: The top stand-offs provide the 10" (254mm) minimum clearance to the header. Use only non-combustible material in this area for the entire width of the fireplace. DO NOT use wood, sheetrock, et cetera, in this zone.

Top stand-off brackets must be formed and attached prior to positioning fireplace into framed opening.

NOTE: If planning to install an optional trim kit assembly, please refer to Section 4.2 Optional Finishing Trim Kit (FTK): #C39-FTK on page 21 before installing stand-offs.

1. Remove and save (4) screws securing stand-off heat shields and stand-off brackets on top of the fireplace.
2. Form each top stand-off bracket by bending at perforations, as shown.
3. Align the holes in the formed top stand-offs with the holes in the fireplace top. Secure with the (4) screws previously removed along with (4) screws located on top of the fireplace.
4. Form stand-off heat shields as shown. The flange will face up and to the back of the fireplace.
5. Align the in the stand-off heat shields with the holes in the top stand-off brackets. Secure with (8) screws provided in the fireplace components packet.

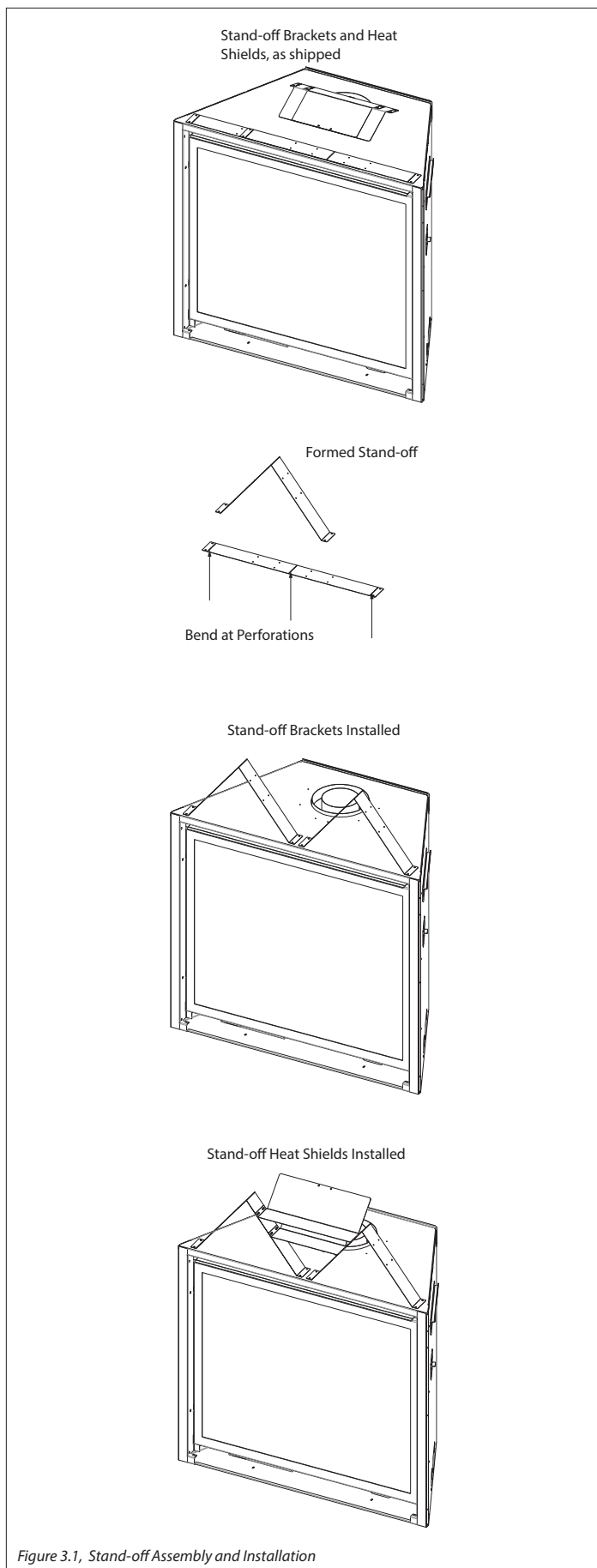

Figure 3.1, Stand-off Assembly and Installation

3.3 Nailing Flange Assembly and Installation

CAUTION: Never permanently remove these assemblies from the fireplace—they must be secured regardless of finish material used. The nailing flanges **MUST BE INSTALLED** for all applications.

1. Remove (2) nailing flanges from the right and left side of the fireplace.
2. Align nailing flange with holes on outside corners of fireplace, with the stand-off flanges on the nailing flanges facing away from the fireplace

3. Secure the nailing flanges to the fireplace with screws (provided) through the slots in nailing flanges.
4. Bend perforation on nailing flange until parallel with fireplace face. Do not bend toward fireplace face.
5. **UNTIL ALL FRAMING REQUIREMENTS ARE COMPLETED:** Position framing stud against the small stand-off (located on backside of nailing flange). Secure with nails or screws.
 - **When installed, the nailing flanges provide the minimum 1/2" (13mm) clearance from the sides of the fireplace to framing.**

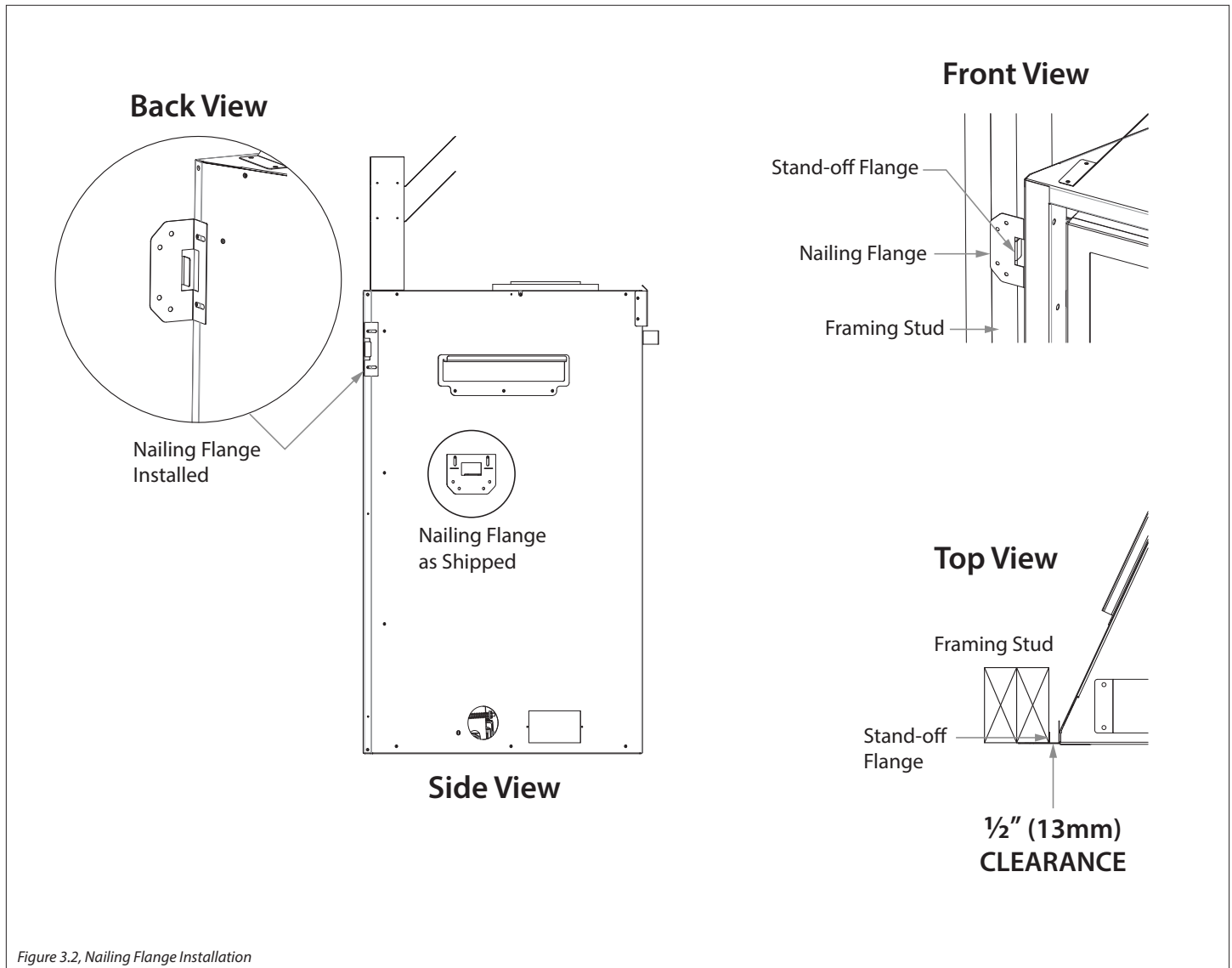

Figure 3.2, Nailing Flange Installation

3.4 Clearances to Combustibles

<i>Table 3.1, Minimum Appliance Clearances to Combustible Material</i>		
From appliance top stand-off brackets	0"	0mm
From appliance left and right stand-off brackets	0"	0mm
From appliance back stand-off brackets	0"	0mm
From appliance corners	1/4"	6mm
From appliance front	36"	914mm
Appliance side to adjacent sidewall	1-1/4"	32mm
Appliance top to 3/4" (19mm) trim	10"	254mm
Mantel 10" (254mm) deep from appliance top	14"	356mm
Appliance top to fireplace enclosure top	30"	762mm
Minimum height of fireplace enclosure	64-1/2"	1638mm

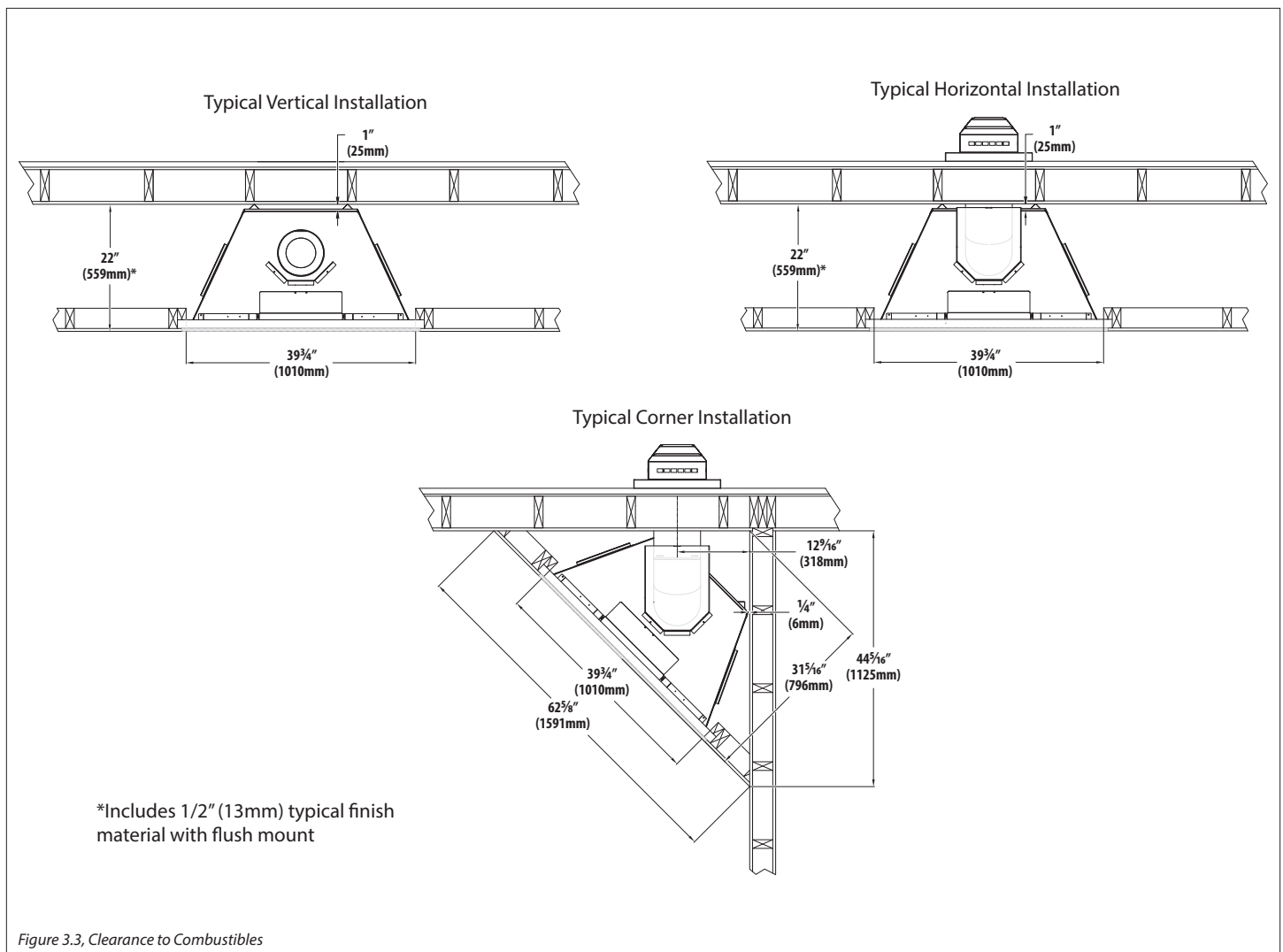

Figure 3.3, Clearance to Combustibles

3.5 Rough Framing

WARNING: Provide adequate clearance in front of the fireplace for barrier removal, component access, gas line installation, service access, etc.

CAUTION: Cold air transfer area. The surround fireplace chase must comply with all clearances as outlined in this manual, and be constructed in compliance with local building codes. Outside walls should be insulated to prevent cold air from entering room.

- Rough framing dimensions should allow for wall covering thickness and fireplace facing materials. Adjust rough opening size as necessary to maintain minimum clearance requirements.
- Floor protection in front of the fireplace is not required. Combustible material may be used if installing a hearth extension. Consider the thickness of the hearth extension finishing material if building a fireplace platform. The bottom of the fireplace must be level with finished hearth extension for proper fit of the safety barriers.
- The bottom of the fireplace must be placed directly on a wood or non-combustible surface (not linoleum or carpet). If this appliance is to be installed directly on carpeting, tile, or other combustible material other than wood flooring, this appliance shall be installed on a metal or wood panel extending the full width and depth of the appliance.

- This fireplace may be elevated off the floor, provided it is properly supported by framing materials and maintains ceiling clearances. If installed above floor level, a solid, continuous platform must be constructed below the fireplace.
- If masonry (optional) is to be used, prepare the foundation necessary for the full masonry load. A lintel must be used over the top of the appliance to support the added weight of the masonry construction above the fireplace.

3.5.1.1 TV Recess Construction

WARNING: All clearances to venting must be maintained.

Mounting a television above a fireplace has become a common practice. Television surface temperatures are affected by mantel depth, ceiling heights, and wall and mantel construction material. Most television manufacturers specify in their instructions that a television should not be installed on, near, or above a heat source.

Television location rests solely on the homeowner. It is the homeowner's responsibility that the preferred TV mounting and mantel design will not exceed the listed maximum operation temperature of their electronic goods.

Tests performed determined that surface temperatures did not exceed 150°F (66°C) when a 4¼" (108mm) deep recess is constructed above the fireplace.

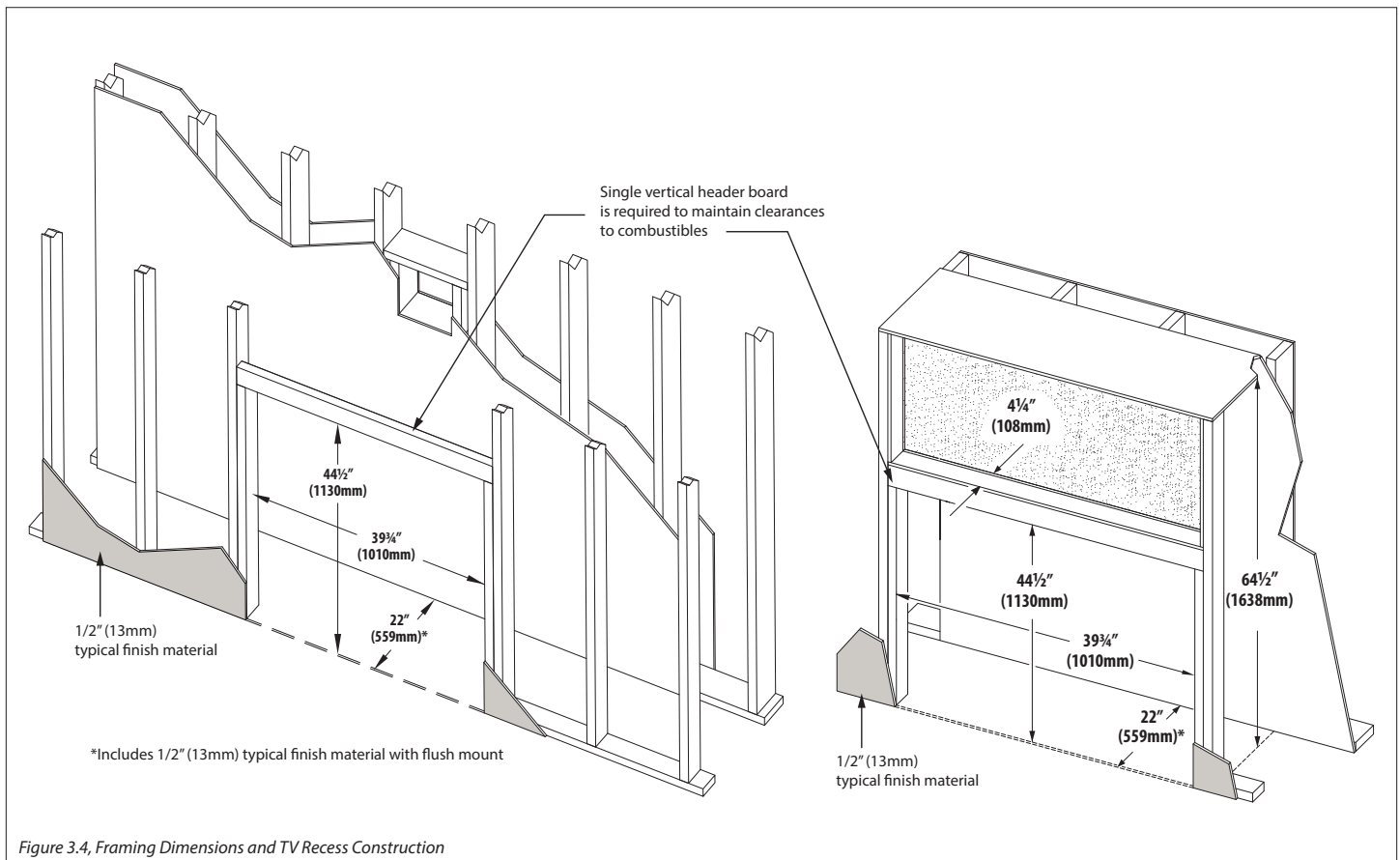

Figure 3.4, Framing Dimensions and TV Recess Construction

3.6 Vent Termination Rough Framing

IMPORTANT: Vent cap location must be in compliance with Section 6.2 Minimum Vent Termination Clearances on page 27.

WARNING: DO NOT RECESS THE VENT CAP INTO WALL OR SIDING.

3.6.1 Vertical Terminations

Follow vent pipe manufacturer's installation instructions for vertical terminations.

- A minimum of 1" (25mm) clearance on all sides of the vertical vent pipe must be maintained.
- Attic insulation shields may be insulated using unfaced insulation products listed as non-combustible per ASTM E 136.

3.6.2 Horizontal Terminations

IMPORTANT: Horizontal vent sections require 1/4" (6mm) rise for every 12" (305mm) of travel for natural draft applications.

NOTE: Elbows listed with approved vent systems for this appliance vary in vertical length. Please consult the vent manufacturer's instructions to determine the elbow dimension used for installation. Adjust the wall pass-through rough opening dimensions to maintain clearance requirements.

IMPORTANT - METAL FAB VENT SYSTEM : When installing Metal Fab vent pipe, an adapter must be used. This will increase the minimum height for the center of the vent pipe by 3-1/4" (83mm) when framing the wall pass through.

- A minimum of 3" (76mm) clearance from the top surface on the horizontal pipe must be maintained.
 - A minimum of 1" (25mm) on the sides and bottom surfaces on the horizontal pipe must be maintained.
1. Measure from floor level of the fireplace to the center of where the vent pipe will penetrate the wall.
 2. Cut and frame an opening in the wall to allow the vent system to run level through the wall pass-through.
 3. Follow the vent pipe manufacturer's installation instructions for draft vent installation.

3.6.2.1 Wall Pass Through Information and Framing

Kozy Heat's #800-WPT series, or wall thimble products that comply with the required 3" (76 mm) top clearance to combustibles, must be installed for all horizontal vent runs that pass through interior or exterior walls. These wall thimble products may be insulated using unfaced insulation products listed as noncombustible per ASTM E 136.

- Rigid pipe dimensions are tested with listed Simpson DuraVent 5" x 8" coaxial pipe venting system ONLY.
- Flexible pipe framing dimensions are tested with Kozy Heat #800 Series Flexible Vent System. See the drawing below.

Wall Thickness.....	Part Number
4 1/2" (114mm) to 6 1/2" (165mm)	#800-WPT
6 1/2" (165mm) to 12 1/2" (318mm)	#800-WPT2
4" (101mm) to 6 1/2" (165mm).....	#800-WPT3

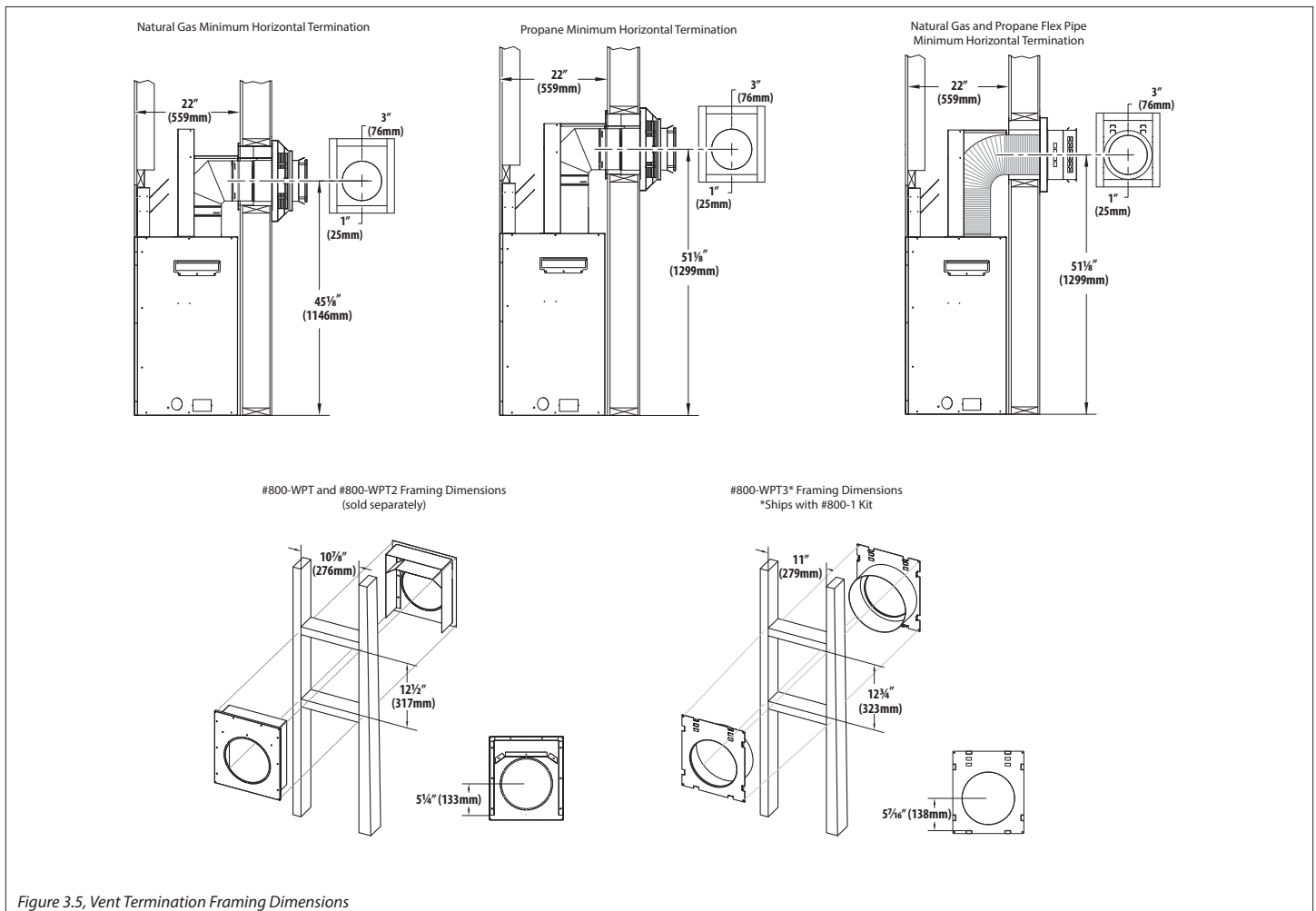

Figure 3.5, Vent Termination Framing Dimensions

3.7 Outdoor Covered Fireplace Installation

An outdoor covered fireplace installation allows a fireplace to be installed in an outdoor covered area, where the appliance is protected from direct precipitation.

Follow the instructions and illustrations on this page and the following page for installation procedures.

3.7.1 Safety Screen Barriers

Hussong Mfg. Co., Inc. highly recommends to use black painted safety barriers in outdoor installations. Other screen barriers that incorporate a plated or patina finish are highly susceptible to oxidation and discoloration.

3.7.2 Requirements

- The continuous insulated building envelope and weatherproof membrane are not to be interrupted by fireplace installation. See Figure 3.7 on the following page.
- Fireplace operation is approved from 40°F to 110°F.
- All wiring connections shall be in accordance with outdoor requirements of NECA NFPA 70.
- All clearances and requirements in your appliance manual must be adhered to.

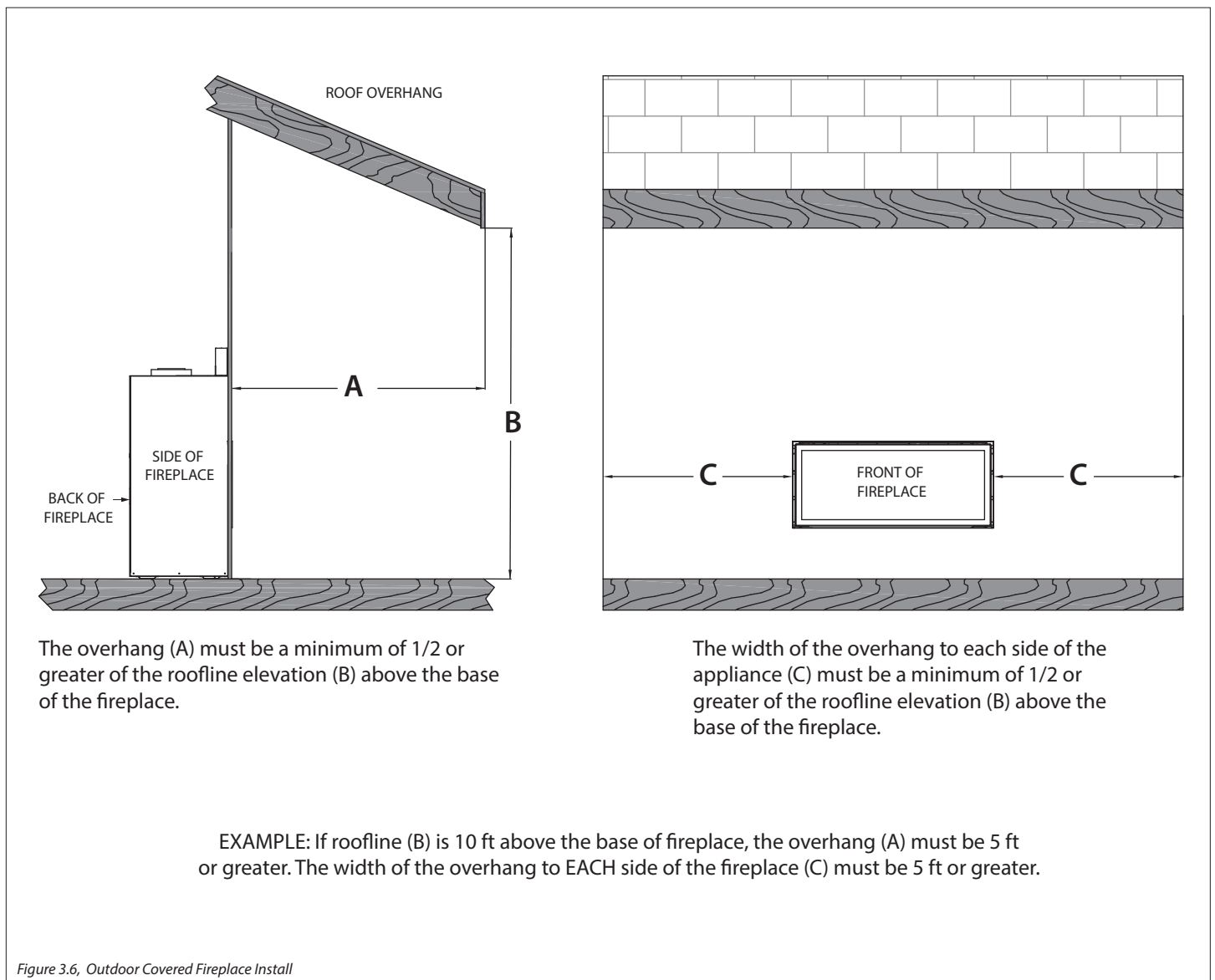

3.7.3 Outdoor Covered Fireplace Installation (continued)

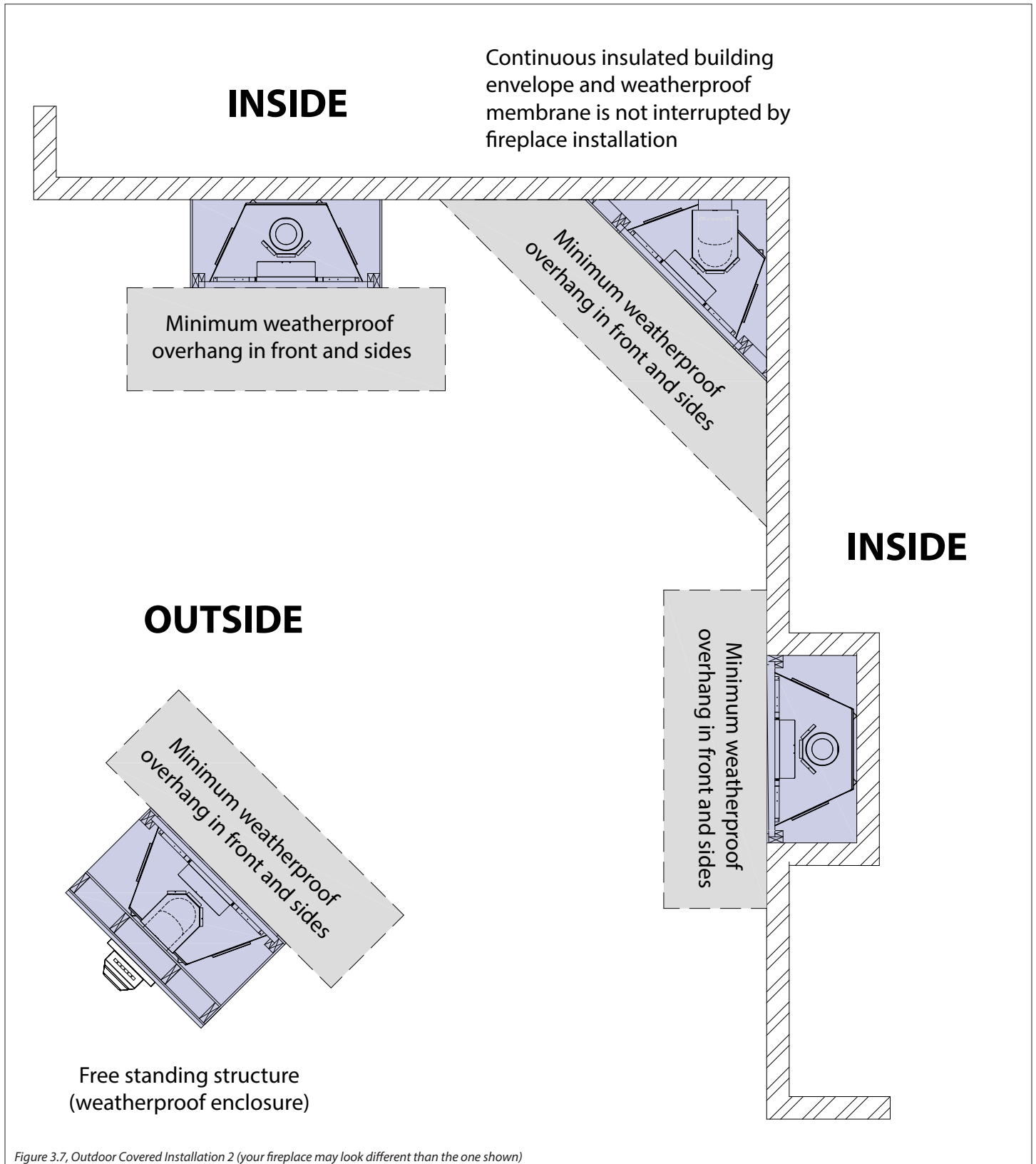

Figure 3.7, Outdoor Covered Installation 2 (your fireplace may look different than the one shown)

4.0 FACING AND FINISHING

4.1 Facing and Finishing Requirements

WARNING: Maintain all minimum clearances to combustibles from the appliance and vent system.

4.1.1 Mantel and Hearth Requirements

WARNING: All minimum clearances to combustible material **MUST** be maintained.

- Combustible Mantel Projections - As referenced in Figure 5.1, the 3/4" trim can start at 10" (254mm) above the top of the appliance with a 10" (254mm) mantel starting at 14" (354mm) above the top of the appliance. Mantel projections can increase 1" (25mm) of depth for every 1" (25mm) of height starting at the 10" (254mm) mantel.
- Non-combustible Mantel Projections - Minimum Vertical and Maximum Horizontal: A minimum vertical clearance of 6" (152mm) above the finishing edge to a maximum 6" (152mm) depth of a non-combustible mantel. Follow projection 1" (25mm) up for every 1" (25mm) deeper.

4.1.2 Adjacent Sidewall Requirements

- The adjacent sidewall minimum clearance is 1-1/4" (32mm) from the appliance sides.

4.1.3 Finishing Recommendations

NOTE: The surface area above the appliance may be affected by high temperatures emitted from this appliance. To help avoid or reduce the possibility of the sheetrock to crack, Hussong Mfg. Co., Inc. recommends the following methods:

- This appliance is shipped with a 1/2" thick non-combustible material (board) that overlaps the header and the sides of framing. See Figure 4.3, Non-Combustible Zone on page 20.
- An optional finishing trim kit #C39-FTK provides a finished edge to hide unfinished edge materials. See Section 4.2 Optional Finishing Trim Kit (FTK): #C39-FTK on page 21.
- Ensure the non-combustible material and sheetrock is dry and dust free.
- For taping and mudding seams, we recommend heat resilient tape, mesh and joint compounds, such as Durabond. Mud must be cured as per manufacturer's recommendations.
- For a painted surface, use a high quality acrylic latex primer and finish coat. Avoid flat or light-colored paints to prevent discoloring.

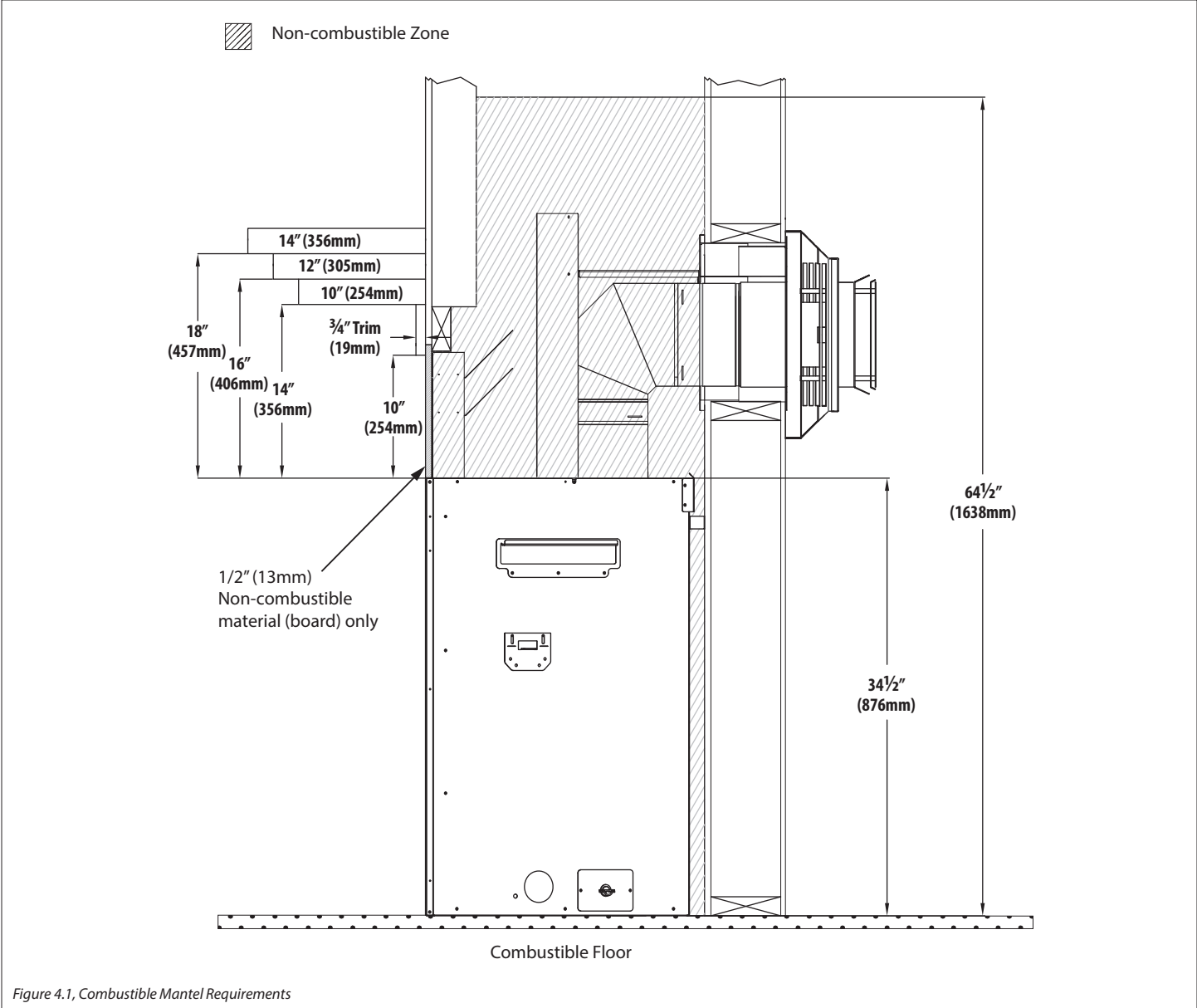

Figure 4.1, Combustible Mantel Requirements

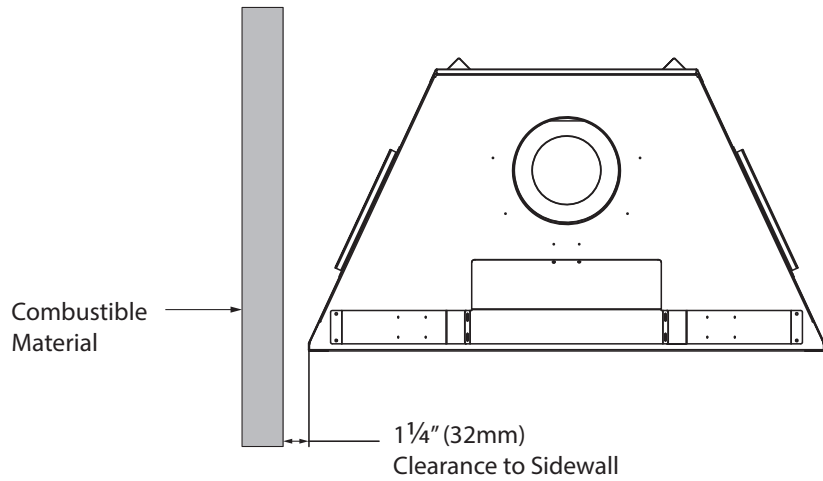

Figure 4.2, Sidewall Clearance

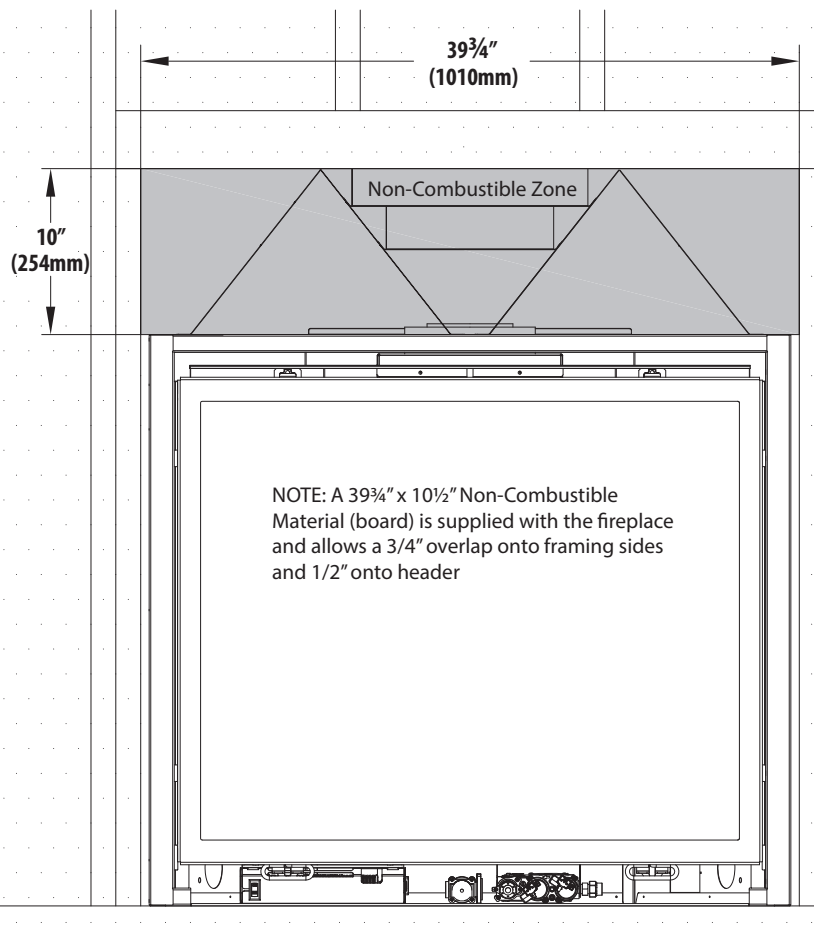

Figure 4.3, Non-Combustible Zone

4.2 Optional Finishing Trim Kit (FTK): #C39-FTK

This optional finishing trim kit (included with the fireplace) provides a 3/4" (19mm) finished edge (black metal) to allow a 1/2" finish board and tile or stone to finish up against creating a shadow box for the safety front.

Use this when finishing around the fireplace with tile or stone. Do not use if you are finishing with 1/2" drywall or non-combustible only, as it will leave 1/4" exposed.

Do not use with safety barrier C39-RSF, an inside mount safety barrier where this is not necessary.

This trim panel assembly should be installed with the top stand-off brackets. Refer to Section 3.2 Stand-off Assembly and Installation on page 11.

1. If installed, remove and discard the existing bottom front frame

portion.

2. Install the bottom trim panel with the flange positioned as shown below. Secure with (2) screws included in the fireplace components packet.
3. If installed, remove the top stand-offs.
4. Install the top trim panel. Align the holes in the top trim panel with the front holes in the stand-offs and attach to the fireplace top. Secure with the screws previously removed and included in the components packet.
5. If installed, remove the nailing flanges from the sides of the fireplace.
6. Install side trim panels, utilizing the existing screws from the top and bottom sides of the fireplace. Install nailing flanges after trim panels, using screws previously removed. Use screws included in the components packet to complete side panel installation.

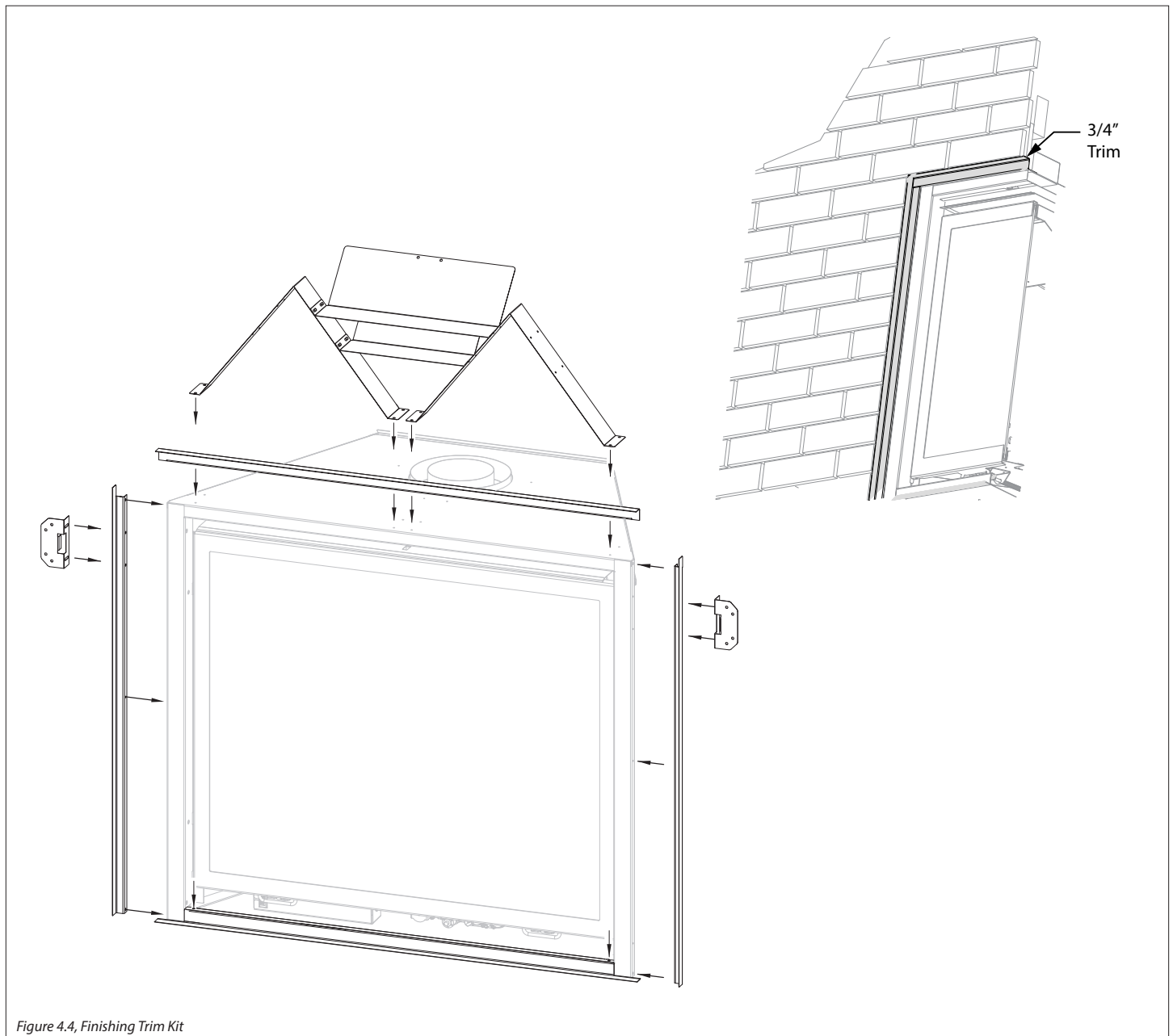

Figure 4.4, Finishing Trim Kit

4.3 Safety Barrier Installation

4.3.1 Inside Fit - Recessed Installation

Model #C39-RSF2

1. Insert the upper hood flange into clips located at the top of the upper air passage. Note: this will be a fairly tight fit.
 2. Install the bottom frame piece. Align the hooks on the bottom frame piece to the corresponding holes in the inside flange on each side of the firebox floor. The bottom frame piece is shipped with safety barrier #C39-RSF2 and must be installed.
 3. Center the screen front over the glass frame assembly, allowing the screen front's mounting brackets to fit inside the air openings.
 4. Align the notched tabs (located on the back of the screen front) with the slots in the fireplace. Raise slightly and push back into position.
 5. Lower screen front until the notched tabs are firmly in position.
- To remove safety screen: lift the screen up and out of slots.

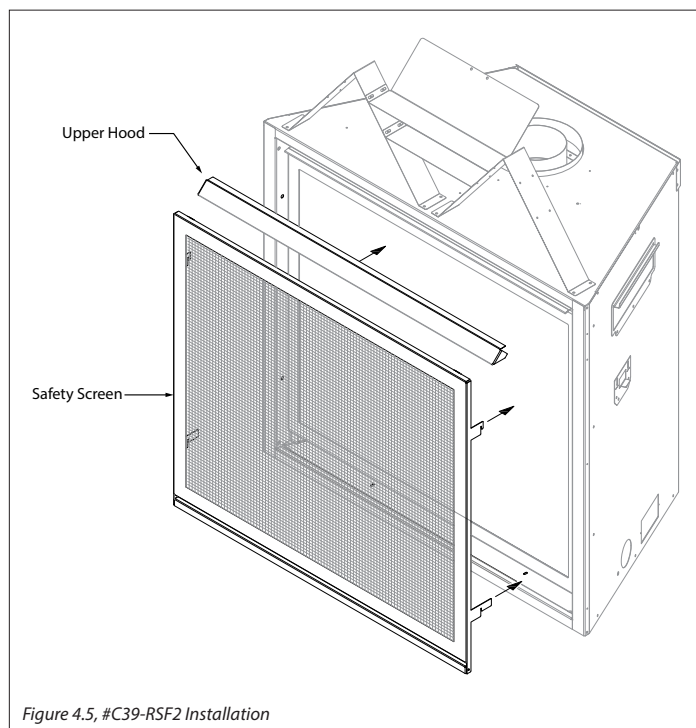

4.3.2 Overlap Fit - Hanging Installation with Adjustable Louvers (Open Bracket)

Models #C39A-MSF, #C39R-MSF, and #C39A-FPDSF2

The listed safety barriers are equipped with the louver built into the safety screen face. The hanging brackets located on the back of screen front are equipped with (2) notched brackets to allow the louver to be adjusted to accommodate facing material thickness. The safety barrier is shipped with the louver in the first notch position.

To adjust louver position:

1. Locate the (2) louver brackets at the bottom of the safety screen. One of the louvers bracket end is open at the top to allow removal and adjustment of the louver depending on the safety barrier position for installation and facing material thickness.
2. Slide the louver up and out on the open bracket end and pull it out of the closed bracket end.
3. Adjust the louver to the desired notch in order to accommodate facing material and to cover the control compartment as you see fit.

NOTE: The position of the louver should match with the desired position of the notched tabs needed for your installation. The louver in the first notch position will match with the first notch position in the notched tabs, the louver in the second notch position will match the second notch in the notched tabs, etc.

4. Reinstall the louver into the closed bracket first, then slide the other end into the open bracket
5. Install safety barrier. Center the screen front over the glass frame assembly, allowing the hanging brackets to fit inside the air openings.
6. Align the notched tabs with the slots in the fireplace. Raise slightly and push back to desired position.
7. Lower the screen front until the notched tabs are firmly in position. Verify the depth of accommodates finish material, and the notched tabs position matches the louver notch position.
8. To remove safety screen: lift the screen up and out of slots.

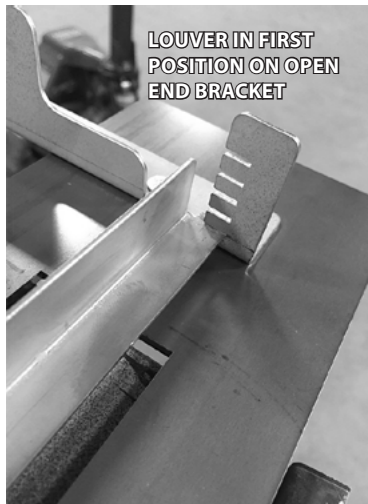
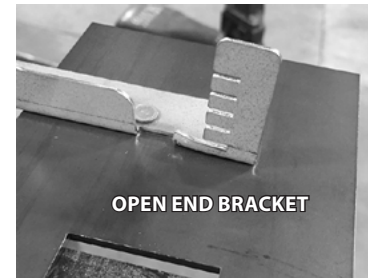
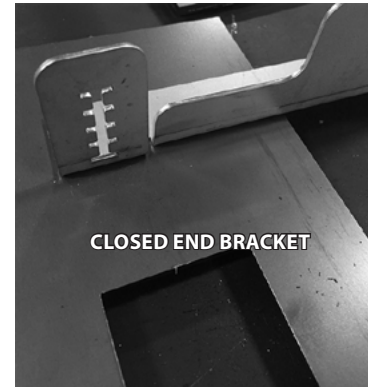

Figure 4.6, Adjustable Louver for C39A-MSF, R-MSF, and A-FPDSF

4.3.3 Overlap Fit - Hanging Installation with Adjustable Louvers (Closed Brackets)

Models #C39-FRSF and #C39-PSF

The listed safety barriers are equipped with the louver built into the safety screen face. The hanging brackets located on the back of screen front are equipped with notches to allow the louver to be adjusted to accommodate facing material thickness. The safety barrier is shipped with the louver in the first notch position.

To adjust louver position:

1. Locate the (3) screws on each hanging bracket at the back of the screen front.
2. Loosen (6) screws on both hanging brackets. This will allow you to bend the bracket outward to adjust the louver to the desired position.
NOTE: The position of the louver should match with the desired position of the notched tabs needed for your installation. The louver in the first notch position will match with the first notch position in the notched tabs, the louver in the second notch position will match the second notch in the notched tabs, etc.
3. Adjust the louver to the desired notch in order to accommodate facing material and to cover the control compartment as you see fit. Re-tighten screws on hanging brackets.
4. Install safety barrier. Center the screen front over the glass frame assembly, allowing the hanging brackets to fit inside the air openings.
5. Align the notched tabs with the slots in the fireplace. Raise slightly and push back to desired position.
6. Lower the screen front until the notched tabs are firmly in position. Verify the depth of accommodates finish material, and the notched tabs position matches the louver notch position.
7. To remove safety screen: lift the screen up and out of slots.

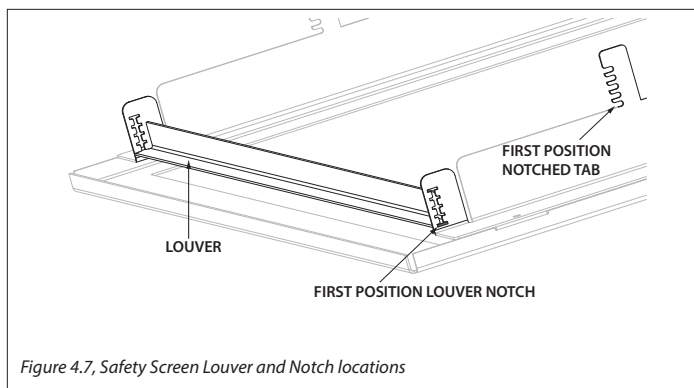

Figure 4.7, Safety Screen Louver and Notch locations

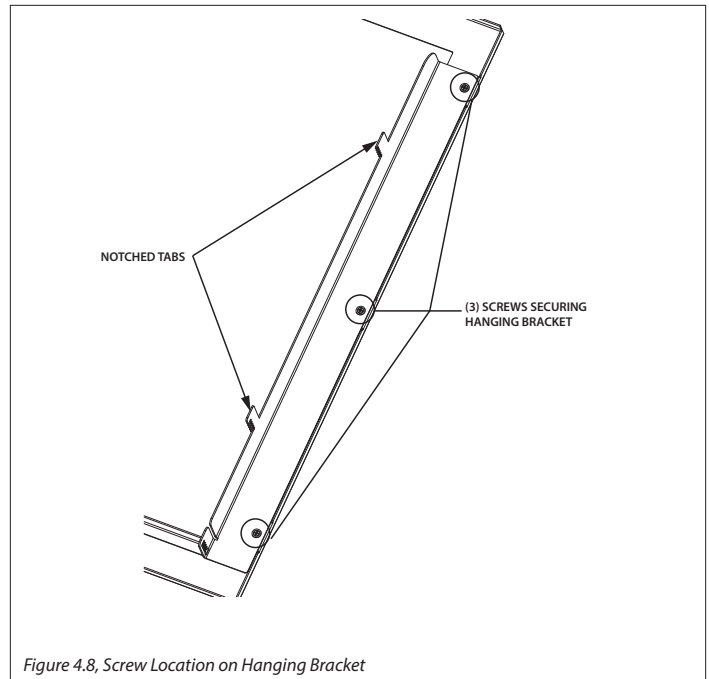

Figure 4.8, Screw Location on Hanging Bracket

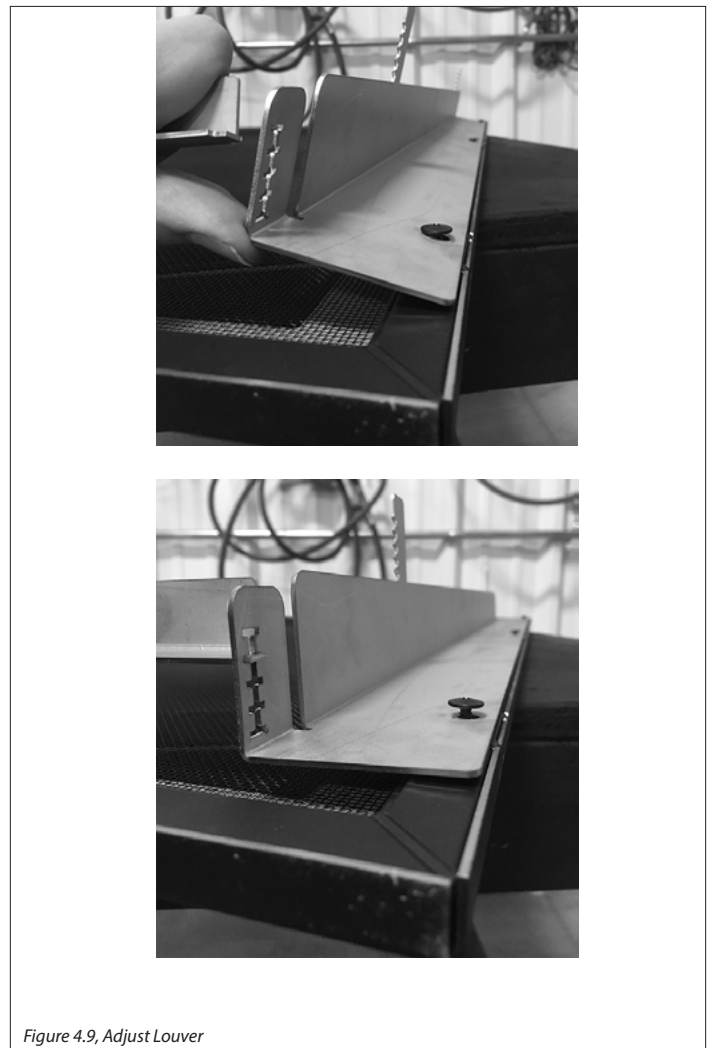

Figure 4.9, Adjust Louver

5.0 GAS LINE CONNECTION

5.1 Gas Conversion (sold separately)

ATTENTION: The conversion shall be carried out in accordance with the requirements of the provincial authorities having jurisdiction and in accordance with the requirements of the ANSI Z223.1 installation code.

This fireplace is manufactured for use with natural gas. Follow the instructions included with the conversion kit if converting to propane.

5.2 Gas Line Installation

CAUTION: Installation of the gas line must only be done by a qualified person in accordance with local building codes, if any. If not, follow ANSI 223.1. Commonwealth of Massachusetts installations must be done by a licensed plumber or gas fitter.

NOTE: The appliance and its individual shutoff valve must be disconnected from the gas supply piping system during any pressure testing of that system at pressures in excess of ½ psi (3.5 kPa). For test pressures equal to or less than ½ psi (3.5 kPa), the appliance must be isolated from the gas supply piping system by closing its individual manual shut-off valve.

- A listed (and Commonwealth of Massachusetts approved) ½" (13mm) tee handle manual shut-off valve and flexible gas connector are to be connected to the ½" (13mm) control valve inlet. If substituting for these components, please consult local codes for compliance.
- This fireplace is equipped with a 3/8" (10mm) x 18" (457mm) long flexible gas connector and manual shut-off valve.
- Run gas line into fireplace into the access hole provided. Figure 2.1, #CAR-39 Dimensions on page 9. The gas line should be run to the point of connection where the shut-off valve and flexible gas line will connect.
- Do not run gas line in a manner that would obstruct fan operation.
- For high altitude installations, consult the local gas distributor or the authority having jurisdiction for proper rating methods.

Table 5.1, Inlet Gas Supply Pressures

Fuel	Minimum Pressure	Maximum Pressure
Natural Gas	5" WC (1.25 kPa) 7" WC (1.74 kPa) <i>recommended</i>	10.5" WC (2.62 kPa)
Propane	12" WC (2.99 kPa) <i>recommended</i>	13" WC (3.24 kPa)

6.0 TERMINATION LOCATIONS

6.1 Vertical Vent Termination

WARNING: This appliance must not share or be connected to a chimney flue serving a separate solid-fuel burning appliance.

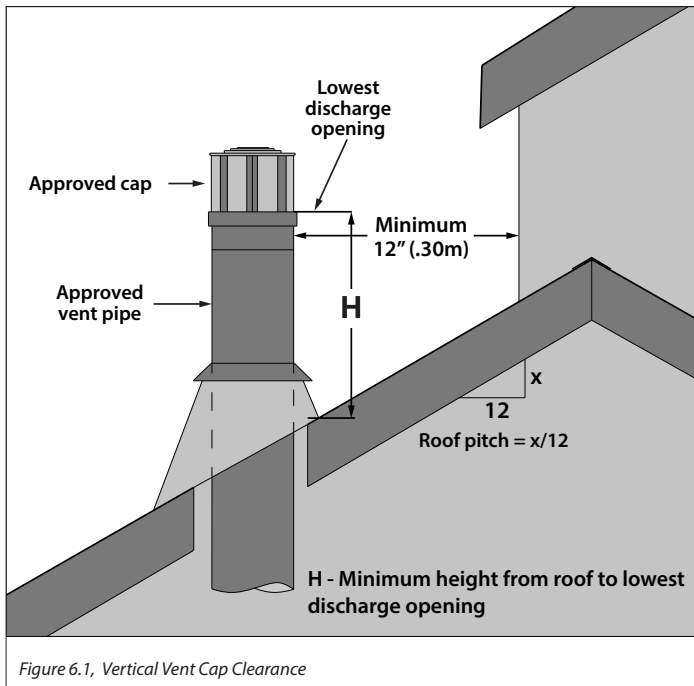

Roof Pitch	Minimum height (H) from roof	
	Feet	Meters
Flat to 6/12	1.0	0.30
Over 6/12 to 7/12	1.25	0.38
Over 7/12 to 8/12	1.5	0.46
Over 8/12 to 9/12	2.0	0.61
Over 9/12 to 10/12	2.5	0.76
Over 10/12 to 11/12	3.25	0.99
Over 11/12 to 12/12	4.0	1.22
Over 12/12 to 14/12	5.0	1.52
Over 14/12 to 16/12	6.0	1.83
Over 16/12 to 18/12	7.0	2.13
Over 18/12 to 20/12	7.5	2.27
Over 20/12 to 21/12	8.0	2.44

6.2 Minimum Vent Termination Clearances

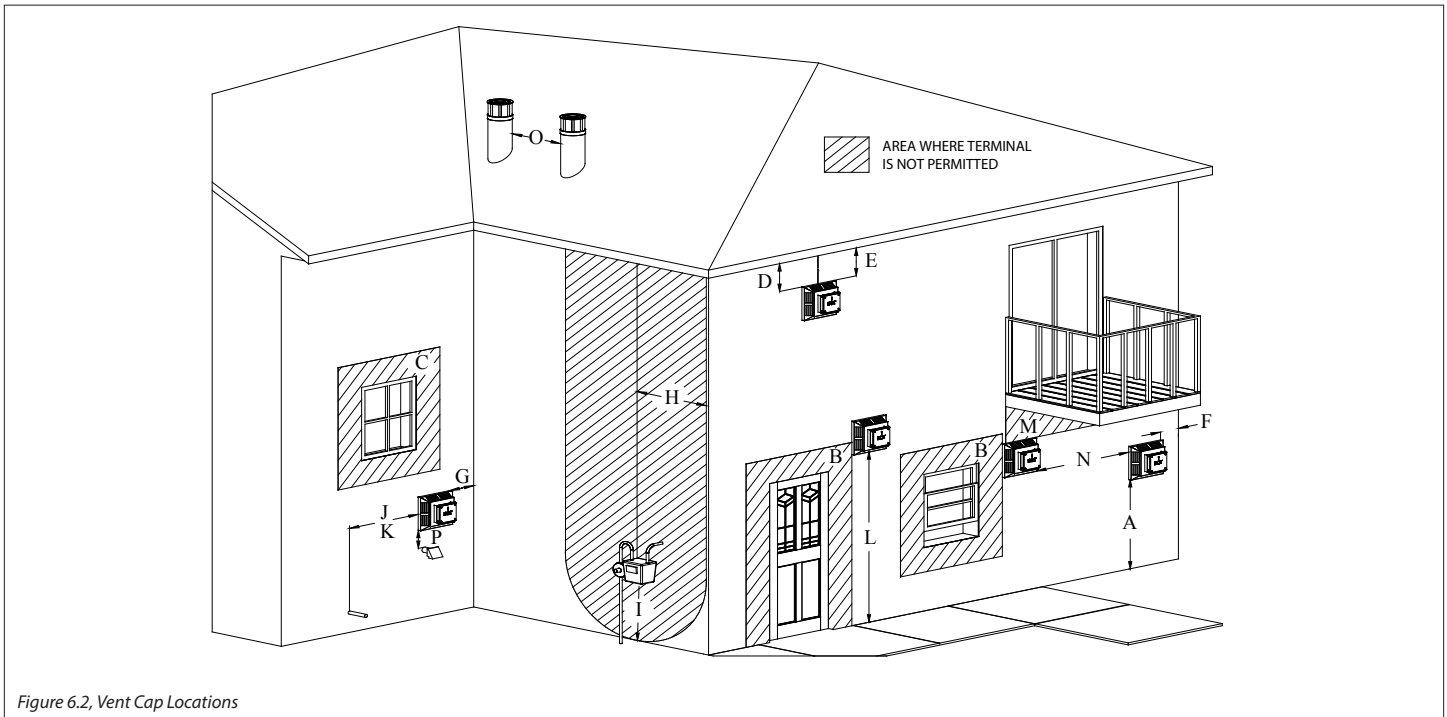

		Canadian installations	US installations
A	Clearance above grade, veranda, porch, deck, or balcony	12" (30cm)	12" (30cm)
B	Clearance to window or door that may be opened	12" (30cm)	9" (23cm)
C	Clearance to permanently closed window (recommended to prevent condensation on window)	12" (30cm)*	12" (30cm)*
D	Vertical clearance to ventilated soffit located above the terminal within a horizontal distance of 2 feet (61 cm) from the center line of the terminal	24" (61cm)*	24" (61cm)*
E	Clearance to unventilated soffit	12" (30cm)*	12" (30cm)*
F	Clearance to outside corner	0" (0cm)*	0" (0cm)*
G	Clearance to inside corner	12" (30cm)*	12" (30cm)
H	Clearance to each side of center line extended above meter/regulator assembly	3' (91cm) within a height 15' (4.5m) above the meter/ regulator assembly	*
I	Clearance to service regulator vent outlet	3' (91 cm)	*
J	Clearance to non mechanical air supply inlet to building or the combustion air inlet to any other appliance	12" (30cm)	9" (23cm)
K	Clearance to mechanical air supply inlet	6' (1.83m)	3' (91cm) above if within 10' (3m) horizontally Massachusetts: 10' (3m)
L	Clearance above paved sidewalk or paved driveway located on public property	7' (2.13m)†	*
M	Clearance under veranda, porch deck, or balcony	12" (30cm)‡	12" (30cm)
N	Clearance between two horizontal terminations	12" (30cm)	12" (30cm)
O	Clearance between two vertical terminations (may be same height)	12" (30cm)	12" (30cm)
P	Above furnace exhaust or inlet	12" (30cm)	12" (30cm)

* Clearance in accordance with local installation codes and the requirements of the gas supplier.

† A vent shall not terminate directly above a sidewalk or paved driveway that is located between two single family dwellings and serves both dwellings.

‡ Permitted only if veranda, porch, deck, or balcony is fully open on a minimum of two sides beneath the floor.

VINYL SOFFIT, VINYL CEILING, AND VINYL OVERHANG DISCLAIMER: Clearances to heat resistant material (i.e. wood, metal). This does not include vinyl. Hussong Manufacturing Co., Inc. will not be held responsible for heat damage caused from terminating under vinyl overhangs, vinyl ceilings, or vinyl ventilated/unventilated soffits.

7.0 VENTING

7.1 Approved Vent Systems

This appliance is equipped for use with a 5" (127mm) exhaust by 8" (203mm) air intake co-axial vent pipe system.

This appliance is approved for use for Kozy Heat 800 Series Flexible Vent Kit (sold separately).

This appliance is approved for use with manufacturers (horizontal and vertical terminations): American Metal Products (Ameri-Vent), BDM, ICC, Metal Fab*, Olympia Chimney Supply, Inc., Selkirk, and Simpson DuraVent.

***WHEN INSTALLING METAL FAB VENT SYSTEM** with this appliance an adapter must be used. Use adapter part number 5DDA.

The following termination caps are not allowed: BDM 940285 Round and 94040836 Snorkel; Simpson DuraVent 58DVA-H2, 58DVA-H2-SNK14, 58DVA-H2-SNK36

Natural gas and propane vent installations terminating with a snorkel cap require a minimum of 12" (305mm) of vertical rise off the top of the appliance before the use of an elbow.

Refer to the vent manufacturer's installation manual for complete installation instructions. Vent installation must conform with venting requirements and restrictions as outlined in this manual.

7.2 Venting Requirements

NOTE: Consult the local and national installation codes to assure adequate combustion and ventilation air is available. Venting requirements apply to both natural gas and propane.

- Flame height and appearance will vary depending upon venting configuration and the type of fuel used.
- Provide a means for visually checking the vent connection to the appliance after the fireplace is installed.
- A minimum of 1" (25mm) clearance on all sides of the vertical vent pipe must be maintained. Attic insulation shields may be insulated using unfaced insulation products listed as noncombustible per ASTM E 136.
- The vent heat shield assembly must be installed for minimum horizontal venting installations for natural gas and propane. The vertical vent heat shield of the assembly **MUST** be installed for every venting installation and application.
- Kozy Heat's #800-WPT series, or wall thimble products that comply with the required 3" (76mm) top clearance and 1" (25mm) side and bottom clearance to combustibles, must be installed for all horizontal vent runs that pass through interior or exterior walls. These wall thimble products may be insulated using unfaced insulation products listed as noncombustible per ASTM E 136.

7.3 Use of Elbows

- MAXIMUM NUMBER OF ELBOWS: 5
- For each additional 90° elbow used after the first elbow, 3' (914mm) must be subtracted from maximum venting allowed.
- For each 45° elbow used, 18" (457mm) must be subtracted from maximum venting allowed.
- (2) 45° degree elbows may be used in place of (1) 90° elbow.

7.4 Vent Restriction

Burner flame appearance and characteristics are affected by altitude, fuel quality, venting configuration, and other factors. To achieve desirable flame appearance, the vent exhaust may be restricted by the restrictor plate (included in components packet) and/or adjust the built-in restrictor located in the fireplace baffle.

The restrictor plate is shipped with all inner rings intact, and when installed, provides the most vent restriction. There are (2) inner rings that can be knocked out. The innermost ring knocked out will create less restriction, and the outer most ring knocked out will create the least amount of restriction. Closing the baffle restrictor will create more vent exhaust restriction.

Follow Figure 7.1 for restrictor plate installation before attaching venting or through the baffle restrictor if venting is already attached. If you are adjusting the baffle restrictor, loosen the (2) thumb screws to adjust the setting to achieve desired flame appearance.

For vent restriction recommendations and adjustments, see Section 11.2.2 Vent Restriction (after installation) on page 47..

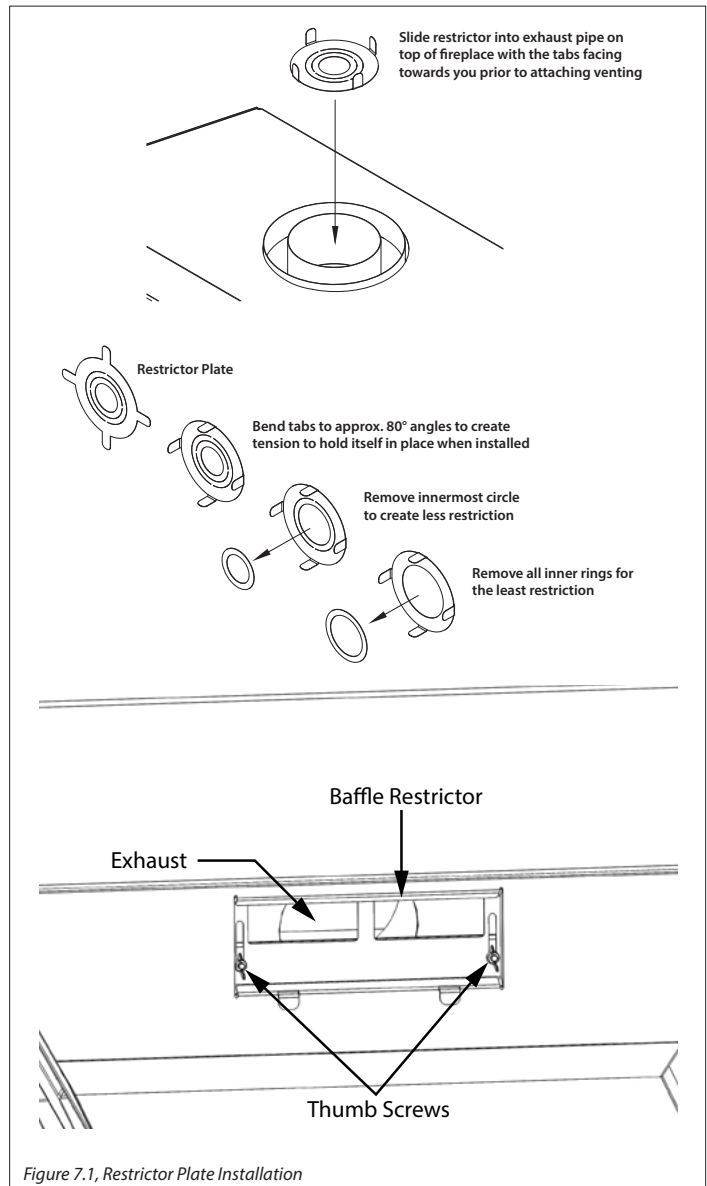

7.5 Rigid Pipe Vent Installation

The vertical vent heat shield must be installed for vertical terminations. Refer to Section 7.7 Vent Heat Shield Assembly Installation on page 34.

7.5.1 Natural Gas and Propane Vertical Terminations

- (i) **Minimum / Maximum Vertical Terminations*:**
4' (1219mm) minimum vertical length / 50' (15.24m) maximum vertical length + termination cap
**Hussong Mfg. Co., Inc. recommends natural gas venting installations, with at least 4' (1219mm) of vertical vent height, to adjust the front air shutter opening to 1/8" (3mm), and to close the back air shutter opening.*

DIAG.1 NATURAL GAS & PROPANE VERTICAL TERMINATIONS

- | | |
|--------------------------------|---|
| (A) Stand-off Brackets | (D) Vertical Vent Heat Shield |
| (B) Stand-off Heat Shields | (E) Horizontal Vent Shield (not applicable) |
| (C) 90° Elbow (not applicable) | (F) Termination Cap |

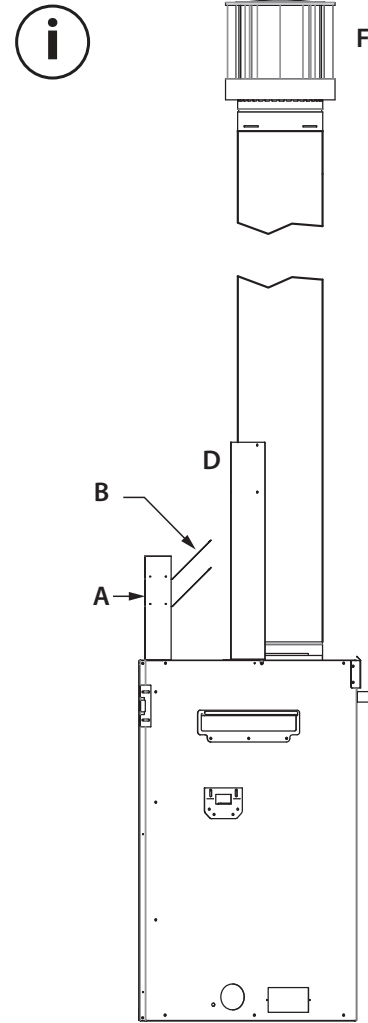

7.5.2 Natural Gas Combination Venting

IMPORTANT: Horizontal vent sections require ¼" (6mm) rise for every 12" (305mm) of travel.

IMPORTANT: Natural gas and propane vent installations terminating with a snorkel cap require a minimum of 12" (305mm) of vertical venting off the top of the appliance before the use of an elbow.

The vertical vent heat shield must be installed for every combination venting installation. The vent heat shield assembly must be installed when installing minimum vertical rise combination venting. Refer to Section 7.7 (pg. 34).

(i) **Minimum 6" Vertical Venting / Minimum / Maximum Horizontal Termination**

6" (152mm) minimum vertical rise + 90° elbow + 6" (152mm) minimum horizontal run / 10' (3m) maximum horizontal run + termination cap

(ii) **Typical Corner Installation**

6" (152mm) minimum vertical rise + 90° elbow + 6" (152mm) minimum horizontal run + termination cap

(iii) **Minimum 18" Vertical Venting / Minimum / Maximum Horizontal Termination**

18" (457mm) minimum vertical rise + 90° elbow + 6" (152mm) minimum horizontal run / 20' (6m) maximum horizontal run + termination cap

7.5.2.1 Natural Gas Maximum Combination Venting

For maximum vertical and maximum horizontal combination venting, the vent terminations must be within the shaded area in Figure 7.2.

- 25' (7.6m) maximum vertical rise + 25' (7.6m) maximum horizontal run = 50' (15.2m) of total length
- Maximum of (5) 90° elbows.

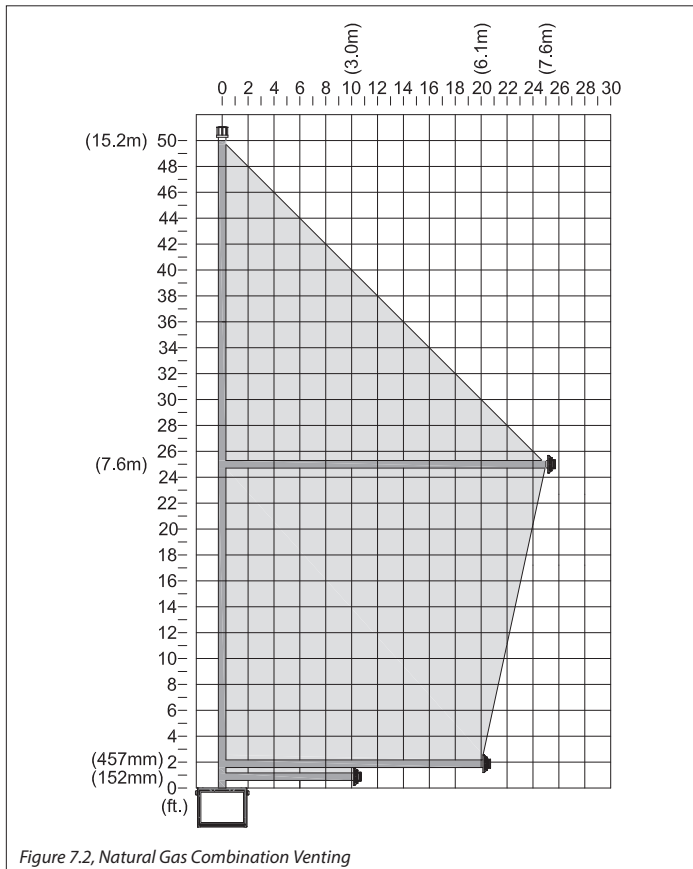
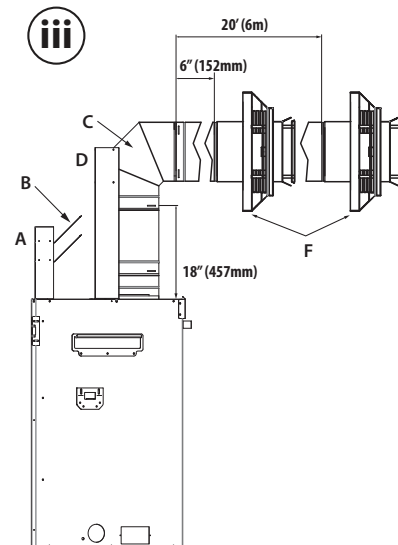
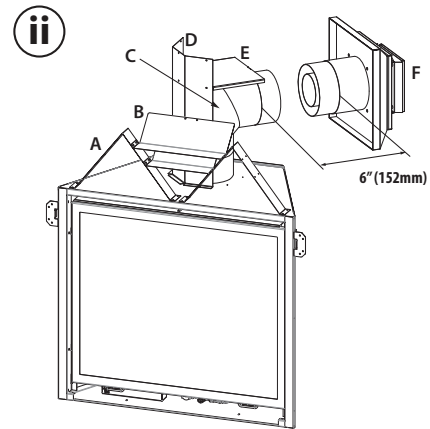
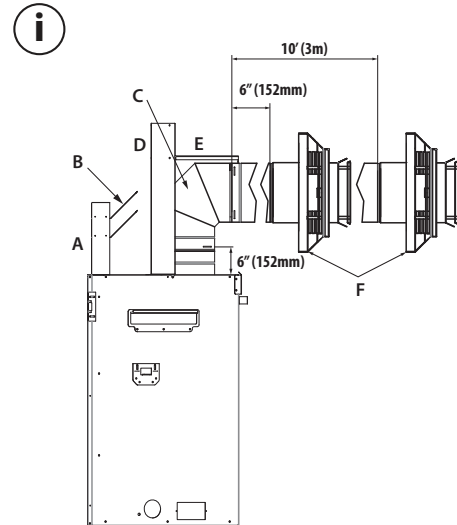

Figure 7.2, Natural Gas Combination Venting

DIAG.2 NATURAL GAS COMBINATION VENTING

- | | |
|----------------------------|-------------------------------|
| (A) Stand-off Brackets | (D) Vertical Vent Heat Shield |
| (B) Stand-off Heat Shields | (E) Horizontal Vent Shield |
| (C) 90° Elbow | (F) Termination Cap |



7.5.3 Propane Combination Venting

IMPORTANT: Horizontal vent sections require ¼" (6mm) rise for every 12" (305mm) of travel.

IMPORTANT: Natural gas and propane vent installations terminating with a snorkel cap require a minimum of 12" (305mm) of vertical venting off the top of the appliance before the use of an elbow.

The vertical vent heat shield must be installed for every combination venting installation. The vent heat shield assembly must be installed when installing minimum vertical rise combination venting. Refer to Section 7.7 (pg. 34).

- (i) **Minimum 12" Vertical Venting / Minimum / Maximum Horizontal Termination**
 12" (305mm) minimum vertical rise + 90° elbow + 6" (152mm) minimum horizontal run / 4' (1219m) maximum horizontal run + termination cap
- (ii) **Typical Corner Installation**
 12" (305mm) minimum vertical rise + 90° elbow + 6" (152mm) minimum horizontal run + termination cap
- (iii) **Minimum 18" Vertical Venting / Minimum / Maximum Horizontal Termination**
 18" (457mm) vertical rise + 90° elbow + 6" (152mm) minimum horizontal run / 8' (2.4m) maximum horizontal run + termination cap

7.5.3.1 Propane Maximum Combination Venting

For maximum vertical and maximum horizontal combination venting, the vent terminations must be within the shaded area in Figure 7.2.

- 25' (7.6m) maximum vertical rise + 25' (7.6m) maximum horizontal run = 50' (15.2m) of total length
- Maximum of (5) 90° elbows.

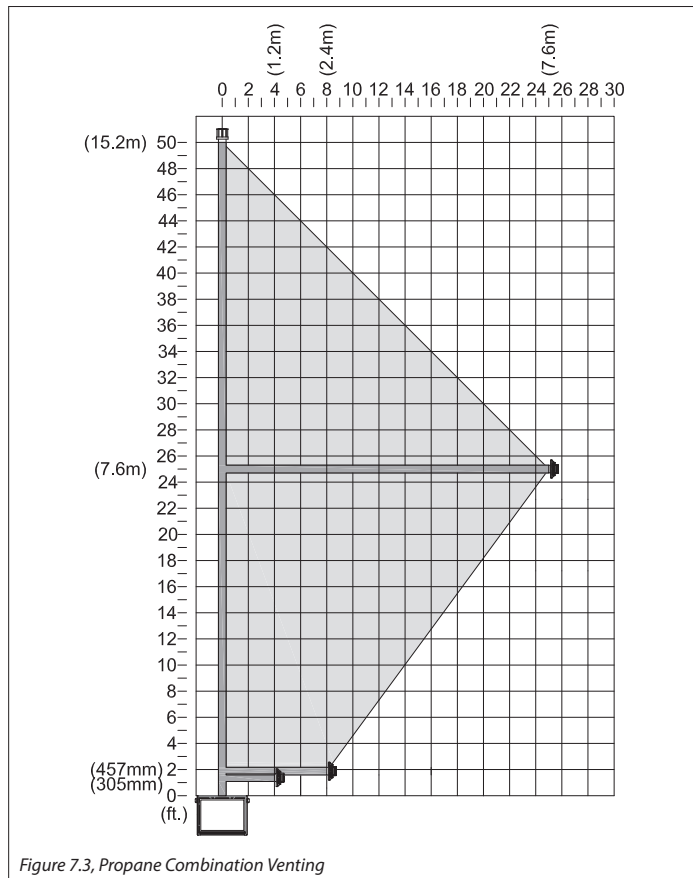
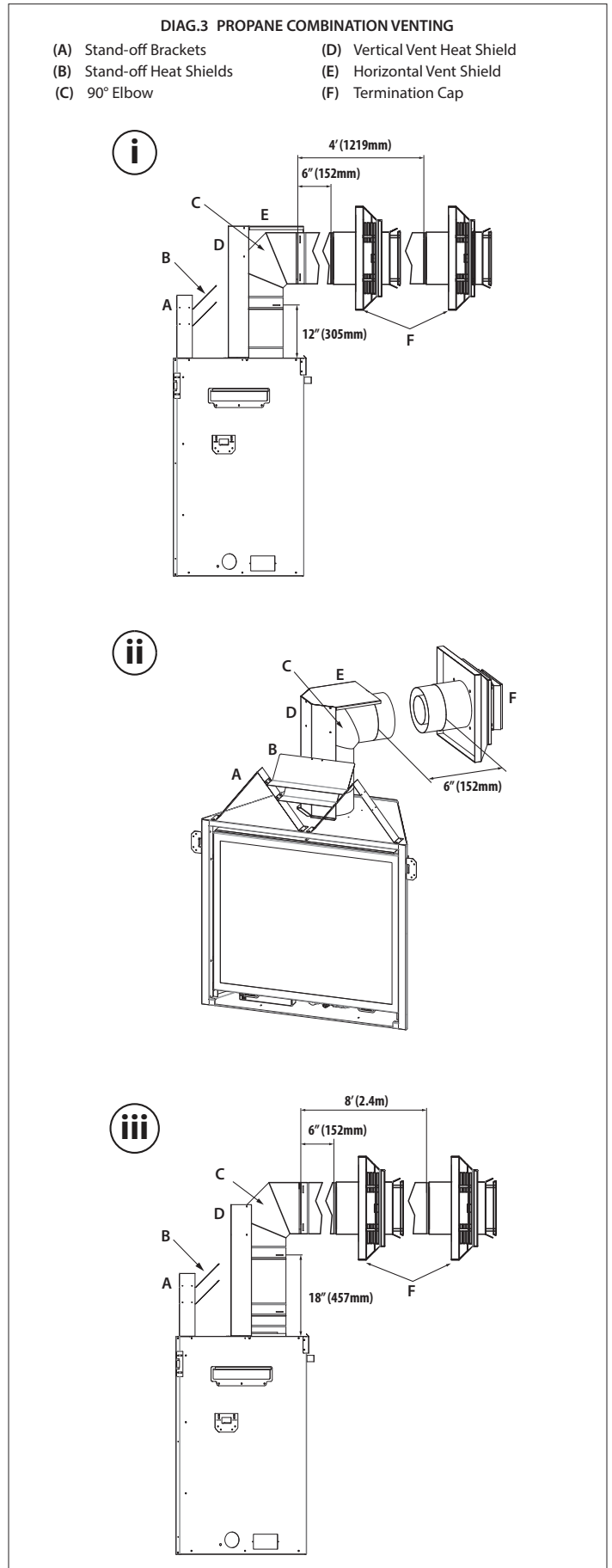

Figure 7.3, Propane Combination Venting



7.6 #800-1 Series Direct Vent Termination Kit(s) Installation

IMPORTANT: The vertical vent heat shield included with this fireplace must be installed for all venting installations. Use the vent heat shield assembly when installing the flexible pipe at the minimum bend radius 6" (152mm) to center.

IMPORTANT: The flex pipe is permanently attached to the exterior plate. DO NOT ATTACH either #844-1 or #845-1 termination kit to fireplace (or extension kit) until it has passed through the wall. Install termination plates to the outside wall exterior.

IMPORTANT: The minimum bend radius to center is 6" (152mm) required for installation of the flexible vent pipe. Care should be taken when installing the flexible vent pipe to avoid a tight bend that may cause abrasion or damage to the flexible pipe.

- If terminating against vinyl siding, a vinyl siding protector must be used (included with the #844-1 and #845-1 direct vent kits). Follow instructions included.
- Each #846-1 extension kit contains enough 5" & 8" flexible aluminum pipe to extend chimney an additional 6' (1.83 m).

7.6.1 Assembly and Installation

1. Mount the required #800-WPT series wall pass through (G) with the required 3" (76mm) top clearance and 1" (25mm) side clearances to the exterior wall, and seal.
2. (OPTIONAL) insulate the wall-pass through with any unfaced insulation products listed as non-combustible per ASTM E 136.
3. Apply a liberal bead of exterior sealant around outer edge of termination box (A), placing assembly through the wall-pass through in exterior wall. Place screws through the four holes (B), securing it in place.
4. Form the 5" & 8" flexible aluminum pipes on termination kit (#844-1 or #845-1), and if applicable, on each extension kit.
5. Gently pull 5" & 8" pipes down to the top of the fireplace, or if applicable, the extension kit.
DO NOT stretch extension kit beyond 6' (1.83m); DO NOT stretch beyond what is required. It is very difficult to decompress flex pipes once stretched.
6. Place a bead of sealant outside 5" flex pipe collar (C) (end with EXTERNAL LIP) and sliding it into 5" pipe on extension kit or top of fireplace (D). Secure with 3 evenly spaced screws.
7. Place a bead of sealant inside 8" flex pipe collar (E) (end with the INTERNAL lip), sliding it over 8" pipe on top of fireplace (F). Secure with 3 evenly spaced screws.
8. If additional extension kits are required, repeat Steps 4 and 5, placing 5" & 8" pipes onto previous extension kit.

Installation instructions for the #800-WPT series wall thimbles are on the following page.

DIAG.4 #800-1 SERIES INSTALLATION

- | | |
|---|--|
| (A) Termination Box | (E) 8" flex pipe collar |
| (B) Exterior wall plate holes (3 shown) | (F) 8" pipe on fireplace or extension kit |
| (C) 5" flex pipe collar | (G) #800-WPT3 or wall thimble with 3" (76mm) top clearance |
| (D) 5" pipe on fireplace or extension kit | (H) Vinyl Siding Protector (not shown) |

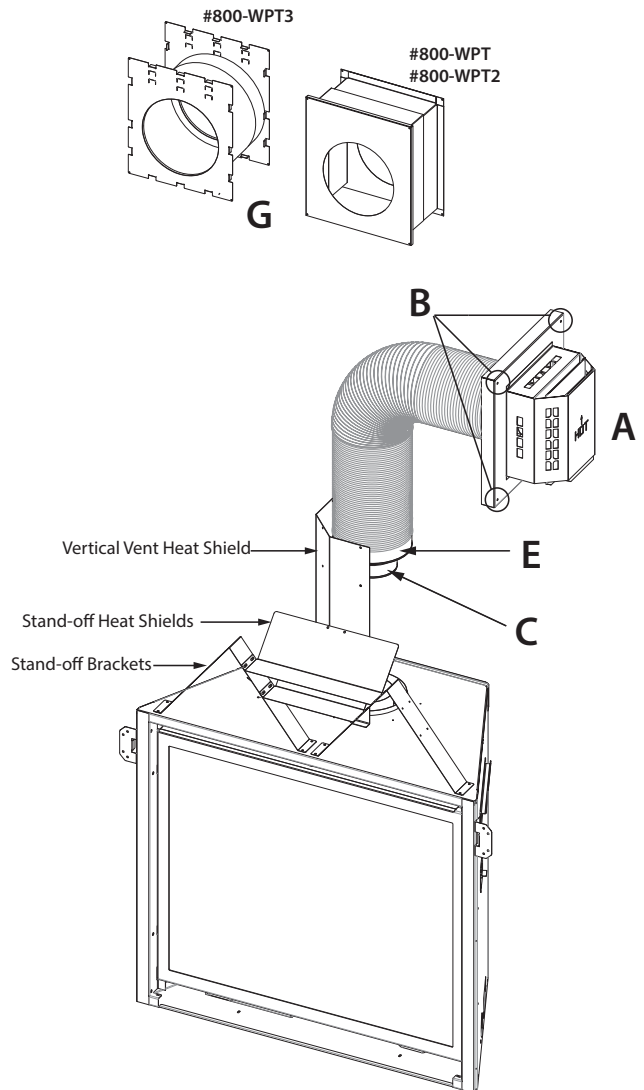

7.6.2 #800-WPT & #800-WPT2 Installation Instructions

If installing Kozy Heat #800 Series Flexible Vent System with either #800-WPT or #800-WPT2, remove inner ring on each wall thimble section with a tin snips. This will provide adequate room for the flexible vent system.

1. Measure wall thickness. Cut the included insulation to this length.
2. Install wall pass-through section marked #1 (with 3/8" [10mm] flange) into framed opening. Secure to interior wall with screws (not provided).
3. From the exterior, place insulation between flange and the top of the framed opening in the wall pass-through section #1, cutting as needed.
4. Install section marked #2 of wall pass-through into framed opening, overlapping metal sections as necessary to accommodate wall thickness. Secure to exterior wall with screws (not provided).
5. Follow vent manufacturer installation instructions for vent installation.

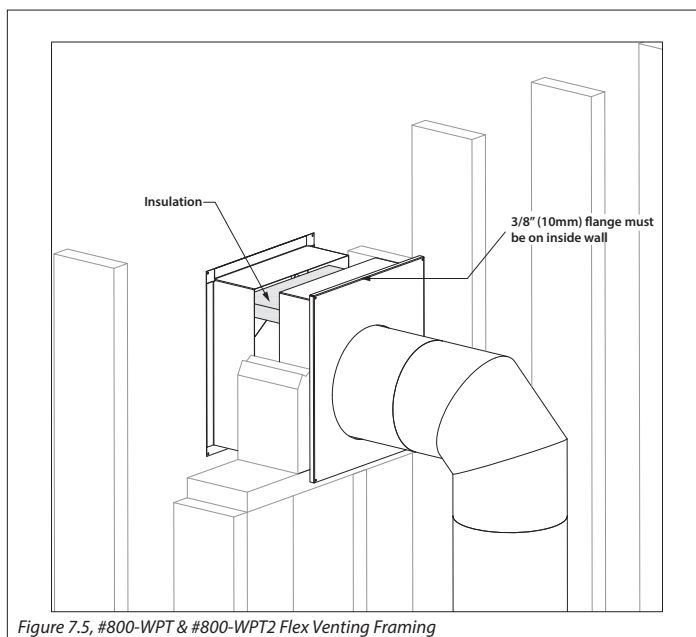
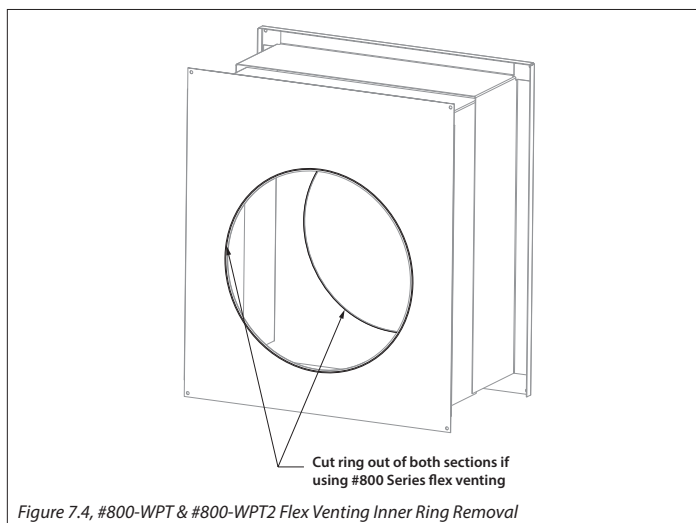

7.6.3 #800-WPT3 Installation Instructions

IMPORTANT: The heat shield within the wall thimble must overlap a minimum of 1-1/2" (38mm). An extension will be needed if going through a thicker wall than 6-1/2" (165mm). Refer to BDM vent manufacturer if wall extension is necessary.

1. Hand bend the (2) tabs on the top of the wall pass through at the 3" (76mm) top required clearance. Hand bend the (6) tabs on the sides and bottom of the wall pass through. Repeat for the other section.
2. From the interior, install one section of the wall pass through. Secure with (4) screws (not provided).
3. From the exterior, install the other section of the wall pass through, overlapping the heat shields as necessary to accommodate wall thickness. The sections must overlap a minimum of 1-1/2" (38mm). Secure to exterior wall with (4) screws (not provided).
4. Follow vent manufacturer installation instructions for vent installation.

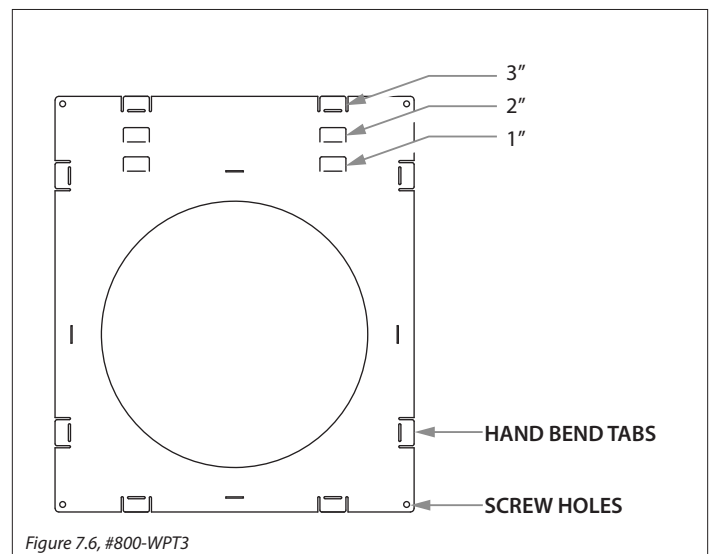

7.7 Vent Heat Shield Assembly Installation

IMPORTANT: The vertical vent heat shield **MUST** be installed for every type of venting application. The horizontal vent heat shield must be installed with minimum horizontal venting for natural gas and propane installations.

NOTE: There are (6) screw holes located in front of the flue outlet to move the vent heat shield assembly in front of the vent pipe. Align the heat shield as necessary for your venting installation.

7.7.1 Vertical Vent Heat Shield Installation

1. Position the vertical vent heat shield in front of the vent pipe, with the flanges facing towards the fireplace face as necessary for the type of installation.
2. Align the (2) slots on the vertical heat shield flanges with corresponding screw holes located in front of the flue outlet on the top of the fireplace.
3. Secure the vertical vent heat shield to the fireplace with (2) attachment screws (provided in the components package).

7.7.2 Minimum Horizontal Venting

1. Bend perforation on the (3) hand-tabs down on the horizontal vent heat shield.
2. Locate (3) screw holes on the vertical vent heat shield. There are (2) sets of screws holes, allowing for either natural gas or propane minimum horizontal venting. See Figure 7.8
3. Align the (3) slots on horizontal vent heat shield tabs to the corresponding (3) screws holes on the vertical vent heat shield necessary for your installation.
4. Attach the horizontal vent heat shield with screws (provided) through the screw holes on the vertical vent heat shield. The 1" (25mm) vent stand-off tab will rest on top of the vent pipe.

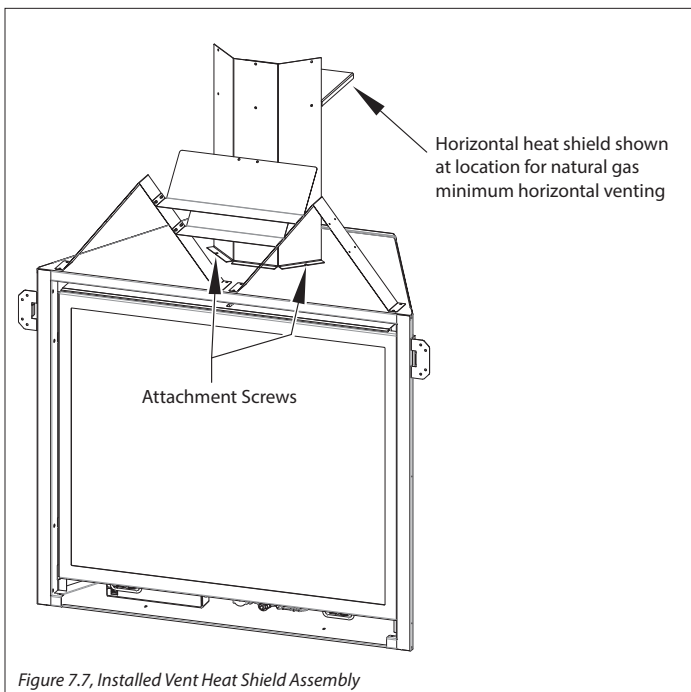
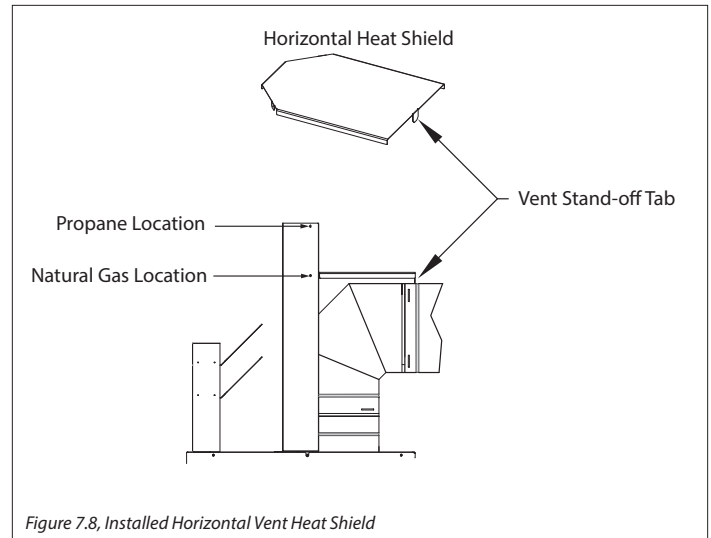

8.0 FIREPLACE SETUP

8.1 Glass Frame Assembly

WARNING: Do not operate this fireplace with the glass removed, cracked, or broken. Replacement of the glass assembly should be done by a licensed or qualified service person.

8.1.1 Remove Glass Frame Assembly

WARNING: Do not remove the glass assembly when hot.

1. Remove the safety barrier.
2. Locate (2) spring-loaded latches securing the glass assembly at the bottom of the firebox.
3. Pull the spring-loaded latches out and down to release the bottom of the glass assembly.
4. Lift glass assembly up and off of the (2) tabs located at the top of the firebox.

8.1.2 Install Glass Frame Assembly

1. Align the slots on top of the glass assembly over the tabs at the top of the firebox while lowering the bottom of the glass assembly into position.
2. Pull the spring-loaded latches out and up to secure the bottom of glass to the bottom of the fireplace.
3. Reinstall safety barrier.

8.2 Light Kit

CAUTION: Disconnect all electrical power from the fireplace before performing this task.

ATTENTION: If converting to propane, complete the conversion before installing any light kit components. Follow instructions provided with the conversion kit (sold separately).

NOTE: To avoid damage and prolong the life of the halogen bulbs, never touch with bare hands. Always use a soft cloth when handling.

8.2.1 Install Light Kit

1. Remove the safety barrier and glass frame assembly.
2. Remove log set (if installed).
3. Remove the front burner from the firebox (2 screws).
4. Remove the back burner tube.
5. Remove the back log plate / burner bracket (2) screws.
6. Remove the burner heat shield (2) screws.
7. Install (4) halogen bulbs (included in component packet) into lamp bases.
8. Reinstall the heat shield, the back log plate/ burner bracket, the back burner tube, and the front burner.
9. Place the crushed glass media (included with the fireplace) into cavity in front of the burner.
10. Randomly place lava rock on top of glass media.
11. Reinstall log set, glass frame assembly, and safety barrier.

8.3 #C39-50B Log Set Installation

CAUTION: Do not place logs directly over burner port holes. Improper log placement may affect flame appearance and cause excessive soot to build upon the logs and glass.

- If converting to propane, complete the conversion before installing the log set. Follow the conversion instructions included with the kit.
 - Log numbers are located on the bottom of each log. Refer to the following instructions and illustrations for proper log placement.
1. Position the ember panel in front of the burner.
 2. Align the slots in the bottom of log C39-1B with the mounting

pins on the back log plate / burner bracket required for your installation. Push log down to seat.

3. Align the holes in the bottom of base logs C39-2B, C39-3B, C39-4B, C39-5B, C39-6B and C39-13B with the mounting pins on the burner. Push logs down on to pins to seat.
4. Align logs C39-7B, C39-8B, and C39-9B with the notches on the base logs.
5. Align log C39-11B with the notch on log C39-8B.
6. Align logs C39-10B and C39-12B with the notches on the ember panel.
7. Distribute rockwool embers onto the logs and burner using a stiff bristle brush.

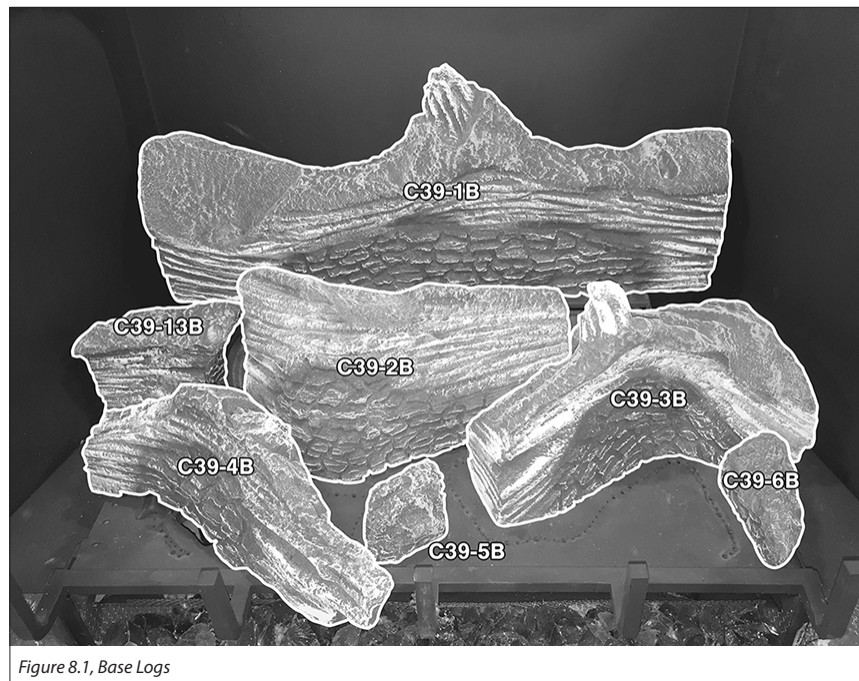

Figure 8.1, Base Logs

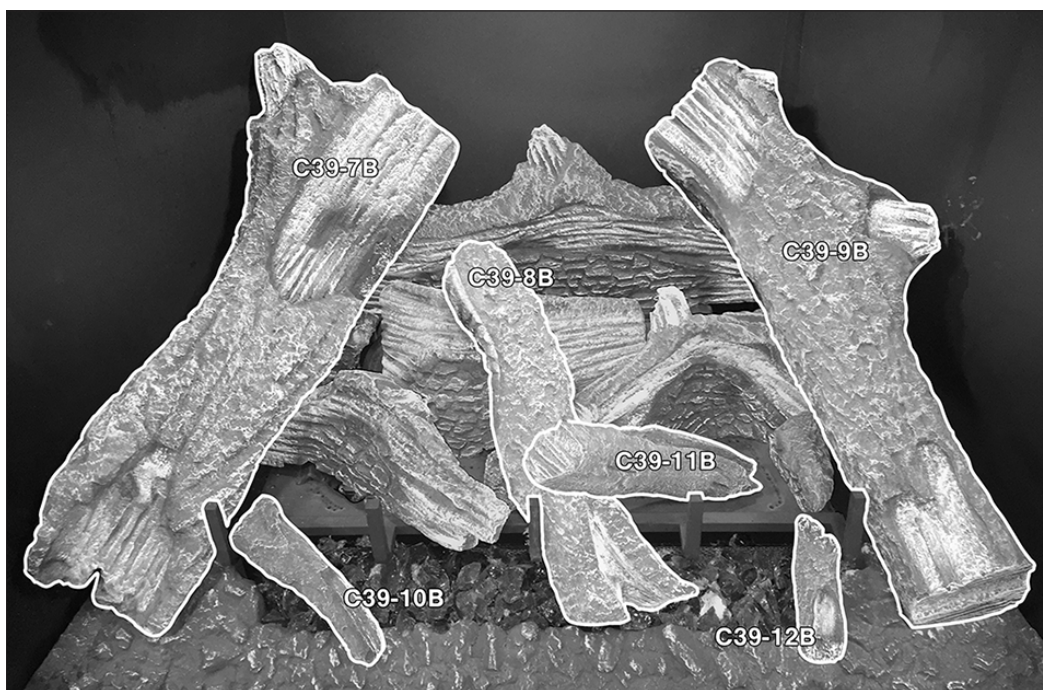

Figure 8.2, Installed Log Set

8.4 Control Board Removal and Installation

WARNING: If burner and/or pilot have been burning, use appropriate protection to avoid burns or damage to personal property before removing any components. DO NOT OPERATE THIS APPLIANCE WITHOUT THE SEALING GASKET (LOCATED UNDER THE CONTROL BOARD) IN PLACE. IF GASKETING IS DAMAGED, IT MUST BE REPLACED.

CAUTION: Check all connections for leaks with soapy water, whether field or factory made.

8.4.1 Control Board Removal

1. Disconnect electrical power.
2. Locate the manual valve installed by your qualified service technician.
3. Turn the manual valve clockwise to the OFF position.
4. Remove the safety barrier and glass frame assembly.
5. Remove logs.
6. Remove the front burner from the firebox (2 screws).
7. Remove the back burner tube.
8. Remove the back log plate/burner bracket (2) screws.
9. Remove the burner heat shield (2) screws.
10. Remove the light kit assembly.
11. Remove and save (10) screws securing the control board. Raise the control board to unplug control module and fan wiring from the control module.
12. Lift the control board and control module out of the firebox, being careful not to damage sealing gasket underneath.

8.4.2 Control Board Installation

1. Place the control module through the firebox and into the control compartment. Plug in control module and fan wiring. **VERIFY SEALING GASKET IS IN PLACE.**
2. Secure the control board to the firebox using (10) screws previously removed.
3. Reinstall the light kit assembly.
4. Reinstall the burner heat shield (2) screws.
5. Reinstall the back log plate/burner bracket (2) screws.
6. Reinstall the front burner. Align the burner over the ports and position the venturi over burner orifice. Secure with (2) screws.
7. Reinstall the back burner tube, positioning the venturi over the burner orifice.
8. Reinstall log set.
9. Reinstall the glass frame assembly and safety barrier.
10. Turn the manual valve counterclockwise to the ON position.
11. Reconnect electrical power.
12. Verify proper log placement, operation of fireplace, and any electrical components.

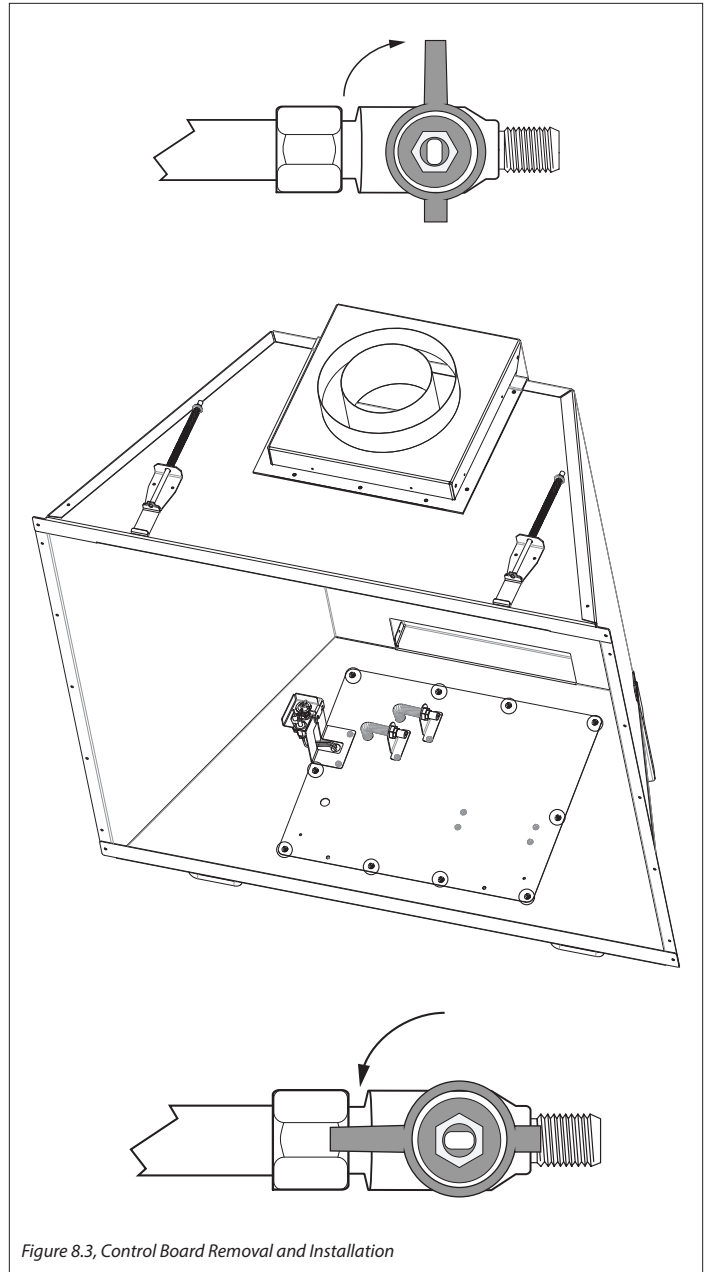

Figure 8.3, Control Board Removal and Installation

9.0 ELECTRICAL INFORMATION

WARNING: Do not use this fireplace if any part has been under water. Immediately call a qualified service technician to inspect this appliance and to replace any part of the control system and any gas control which has been under water.

WARNING - Electrical Grounding Instructions: This appliance is equipped with a three-prong (grounding) plug for your protection against shock hazard and should be plugged directly into a properly grounded three-prong receptacle. Do not cut or remove the grounding prong from this plug.

9.1 Electrical Specifications

This appliance, when installed, must be electrically grounded in accordance with local codes, or in the absence of local codes, with

the National Electrical Code, ANSI/NFPA 70, or the Canadian Electrical Code, CSA C22.1.

9.2 Wiring Requirements

- The IFC System Module requires 120V of electricity and/or batteries to operate.
- Using the battery back-up will operate the burner only.
- Fan and light components will not function on battery back up power.

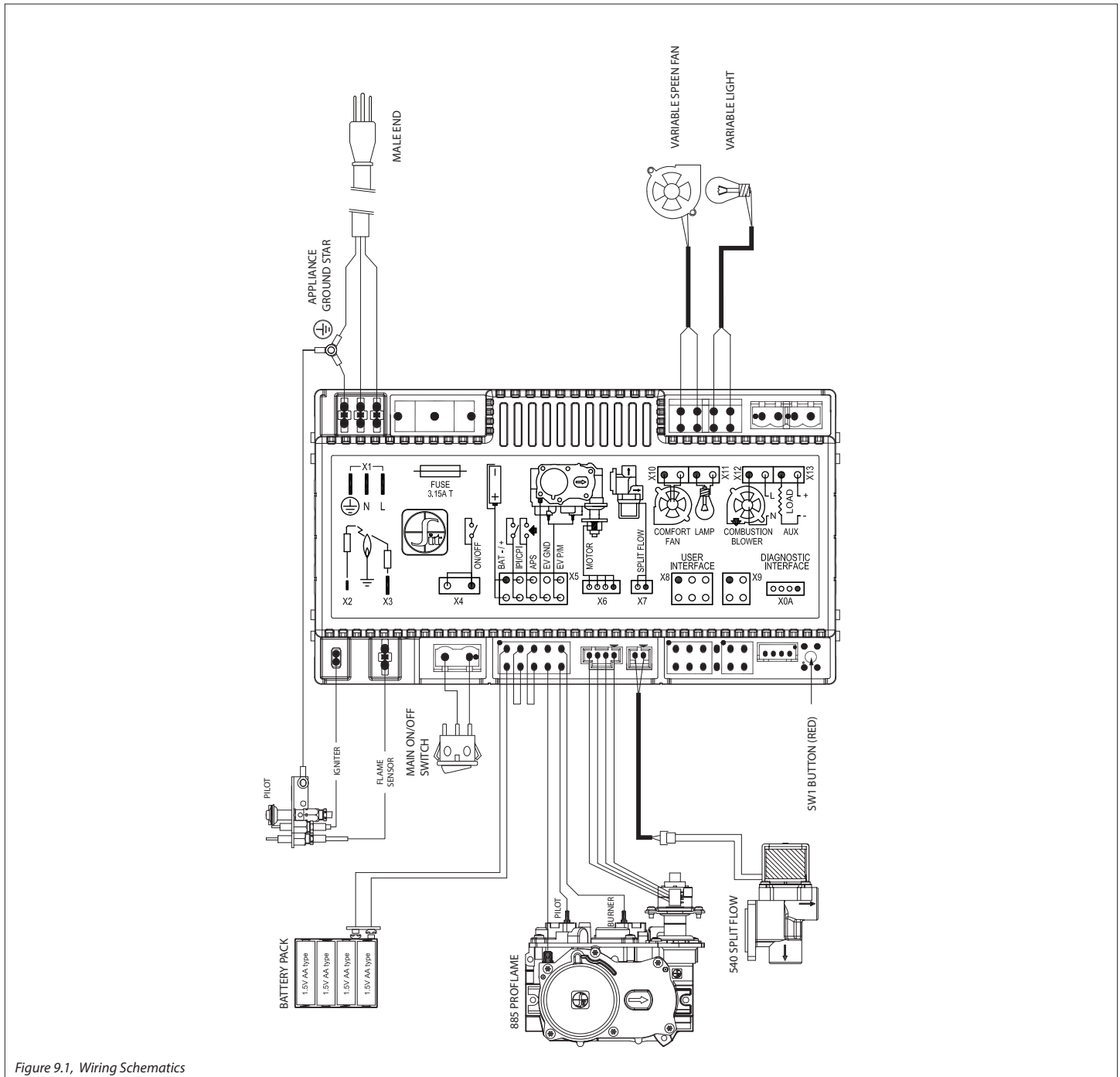

Figure 9.1, Wiring Schematics

10.0 OPERATING INSTRUCTIONS

FOR YOUR SAFETY READ BEFORE OPERATING

WARNING: If you do not follow these instructions exactly, a fire or explosion may result causing property damage, personal injury, or loss of life.

- A. This appliance is equipped with an ignition device which automatically lights the pilot. Do not try to light the pilot by hand.
- B. **BEFORE OPERATING** smell around the appliance area for gas. Be sure to smell next to the floor because some gas is heavier than air and will settle on the floor.
- WHAT TO DO IF YOU SMELL GAS
- Do not try to light any appliance.
 - Do not touch any electric switch; do not use any phone in your building.
 - Immediately call your gas supplier from a neighbor's phone.
- C. Follow the gas supplier's instructions.
- If you cannot reach your gas supplier, call the fire department.
- D. Use only your hand to turn the gas control manual valve. Never use tools. If the valve will not turn by hand, do not try to repair it; call a qualified service technician. Force or attempted repair may result in a fire or explosion.
- E. Do not use this appliance if any part has been under water. Immediately call a qualified service technician to inspect the appliance and to replace any part of the control system and any gas control that has been under water.

WARNING

Do not operate appliance with the glass front removed, cracked, or broken. Replacement of the glass should be done by a licensed or qualified service person.

Under no circumstances should any solid fuel (wood, coal, paper, cardboard, etc.) be used in this appliance.



Children and adults should be alerted to the hazards of high surface temperature and should stay away to avoid burns or clothing ignition.

CAUTION

Clothing or other flammable material should not be placed on or near the appliance.

Young children should be carefully supervised when they are in the same room as the appliance. Toddlers, young children and others may be susceptible to accidental contact burns. A physical barrier is recommended if there are at risk individuals in the house. To restrict access to a fireplace or stove, install an adjustable safety gate to keep toddlers, young children and other at risk individuals out of the room and away from hot surfaces.

OPERATING INSTRUCTIONS

1. STOP! Read all the safety information above on this page.
2. Press the wireless remote OFF button.
3. Turn off all electric power to the appliance.
4. This appliance is equipped with an ignition device which automatically lights the pilot. Do not try to light the pilot by hand.
5. Locate the manual valve installed by your qualified service technician.
6. Turn the manual valve clockwise  to the OFF position.
7. Wait five (5) minutes to clear out any gas. Then, smell for gas, including near the floor. If you smell gas, STOP! Follow 'B' in the safety information above. If you do not smell gas, go to the next step.
8. Turn the manual valve counterclockwise  to the ON position.
9. Turn on all electric power to the appliance.
10. Press the wireless remote ON button.
11. If the appliance will not operate, follow the instructions, "To Turn Off Gas To Appliance" and call your service technician or gas supplier.

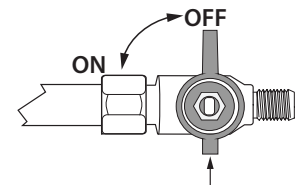
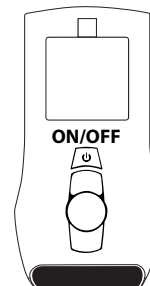

TO TURN OFF GAS TO APPLIANCE

1. Press the wireless remote OFF button.
2. Turn off all electric power to the appliance if service is to be performed.
3. Locate the manual valve installed by your qualified service technician.
4. Turn the manual valve clockwise  to OFF position.

NOTE

When this fireplace is initially lit, condensation will appear on the glass. This is normal in all gas fireplaces and will disappear after several minutes. A paint smell will occur during the first few hours of burning. It is recommended to leave the fan off during this period to help speed the paint curing process. This fireplace may produce noises of varying degree as it heats and cools due to metal expansion and contraction. This is normal, and does not affect the performance or longevity of the fireplace.

10.1 Setup Proflame 2 IFC Module

1. Set the main ON/OFF rocker switch in the OFF position.
2. Install (4) AA batteries (not included) into backup battery holder on the control module.
3. Install (3) AAA batteries (included in the components packet) in the remote control battery bay, located at the base of the remote.
4. Connect the IFC Module to an AC power supply.

10.2 Initialize the Control System

IMPORTANT: Remove all packaging and combustible material from the firebox before initializing the control system.

NOTE: Performing the next steps will initiate pilot start-up in manual mode, where the pilot igniter will spark repeatedly. The pilot will ignite if gas is supplied to the fireplace.

1. Locate the red SW1 button the IFC module.
2. Press the SW1 button. The IFC module will BEEP (3) times and illuminate an amber LED. This indicates the receiver is ready to synchronize with the transmitter.
3. Within (5) seconds, push the ON/OFF button on the remote control. The receiver will BEEP (4) times to indicate the transmitter's command is accepted, and is set to the transmitter's particular code. The pilot will automatically ignite.
4. Press the remote control ON/OFF button again. The pilot will extinguish, confirming the remote control command. The control system is now initialized.
5. Set the main ON/OFF rocker switch to ON position for remote control operation of the main burner and fireplace features.

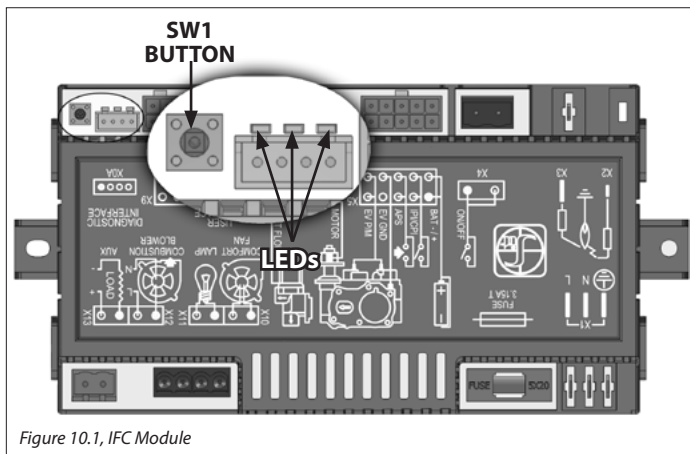

Figure 10.1, IFC Module

10.3 Reset the System for Manual Operation

1. Set the ON/OFF rocker switch to OFF position.
 2. Press the red SW1 button on the IFC module until it emits (3) beeps and an amber LED is illuminated.
 3. Within (5) seconds, press the red SW1 button again. This will close synchronization with the remote control. The pilot will automatically light.
- Turn the main burner ON by setting the ON/OFF switch in ON position. The main burner will only operate on HI.
 - Turn the main burner OFF by setting the ON/OFF switch in the OFF position. The pilot will remain lit even if burner is turned off, provided CPI mode is turned on.

10.4 Automatic Safety Restart

- This system will execute an automatic turn OFF command for approximately (5) seconds within (24) hours of a continued pilot flame ignition to perform a safety check. This allows the system to verify correct safety functions.
- After the turn OFF sequence is completed, the IFC module will re-execute the latest command.

10.5 Backup Battery Operation

This appliance will operate on the backup battery pack when electric power is interrupted, or in a power outage. The lifespan of the backup batteries depend on various factors, such as the quality of the batteries, number of ignitions, et cetera.

- When the backup battery pack is low, the IFC module will emit a double-beep while receiving an ON/OFF command.
- No commands will be accepted after this alert until the back up batteries are replaced.
- Once replaced, the IFC module will emit a 'beep' as soon as it is powered.

10.6 Control System 7 Day Timeout

- If you have your Proflame 2 system set to CPI (continuous pilot ignition) with **7 consecutive days** without ignition of the main burner, the pilot will turn off. This a standard safety feature of the SIT Proflame 2 system.
- Once you turn CPI on, the **7** day timer will start. If at any time during the following **7** days your main burner ignites, it will reset the timer back to **7** days.
- See Section 10.9.3 Pilot Ignition Selection (IPI/CPI) on page 42 for more information.

How to check if your system is set to CPI:

The LCD screen will display the snowflake icon.

To select the preferred pilot ignition feature,

1. With the system in the OFF position, press the mode key to index the CPI mode icon.
2. Press the up arrow key to activate CPI.
3. Press the down arrow key to return to IPI. A single 'beep' will confirm reception of the command.

To Turn ON the appliance:

1. With the system in the OFF position, press the remote control ON/OFF key to turn ON the appliance. A single 'beep' will emit from the IFC module to confirm reception of the command.

The LCD screen will display all active icons, and the IFC module will start the ignition sequence.

10.7 IFC Module Ignition Sequence

The IFC module will try (2) times for ignition, each lasting approximately (60) seconds, with approximately (35) seconds between each attempt.

1. With the system in OFF position, press the remote control ON/OFF key. Approximately (4) seconds after this key is depressed, the IFC module will generate sparks to the pilot hood.
2. First ignition attempt will generate sparks for (60) seconds.
3. If there is no flame ignition (rectification) within the (60) second time frame, the IFC module will stop generating sparks for approximately (35) seconds.
4. After (35) seconds of wait time, the IFC module will generate sparks for another (60) seconds for the second ignition attempt.
5. If there is no positive rectification after (60) seconds, the IFC module will go into a lock out. The red LED will blink (3) times, in intervals, until the system is reset.

10.7.1 Reset IFC Module after Lockout

10.7.1.1 ON/OFF Rocker Switch

1. Set the ON/OFF rocker switch to the OFF position.
2. After approximately (2) seconds, move the switch to the ON position. The ignition sequence will start again.

10.7.1.2 Remote Control ON/OFF Key

1. Press the remote control ON/OFF key to turn the system OFF.
2. After approximately (2) seconds, press the ON/OFF key again. The ignition sequence will start again.

10.7.1.3 Cycling Flame

1. Press the remote control down arrow key during flame adjustment mode to reduce the flame to OFF (indicated by OFF displayed on the LCD screen).
2. After approximately (2) seconds, press the up arrow key. The ignition sequence will start again.

10.8 Additional Diagnostic Information

Low Battery Condition (<4V) Remote Control:

- Battery Icon will appear on LCD remote control display.
- Replace batteries.

Low Battery Condition (<4V) Battery Backup:

- The red LED Indicator will blink (1) time in intervals.
- A low double-beep emits from the IFC control module when it receives an ON/OFF command from the remote control..
- Replace Batteries.

Pilot Flame Error Condition:

- Red LED Indicator will blink (2) times in intervals. Contact your dealer if this occurs.

System Lock Out Condition:

- Red LED Indicator will blink (3) times in intervals.
- Verify gas is turned on.
- Verify sensor is not shorted.
- Follow Section 10.2 Initialize the Control System.

PROFLAME 2 TRANSMITTER

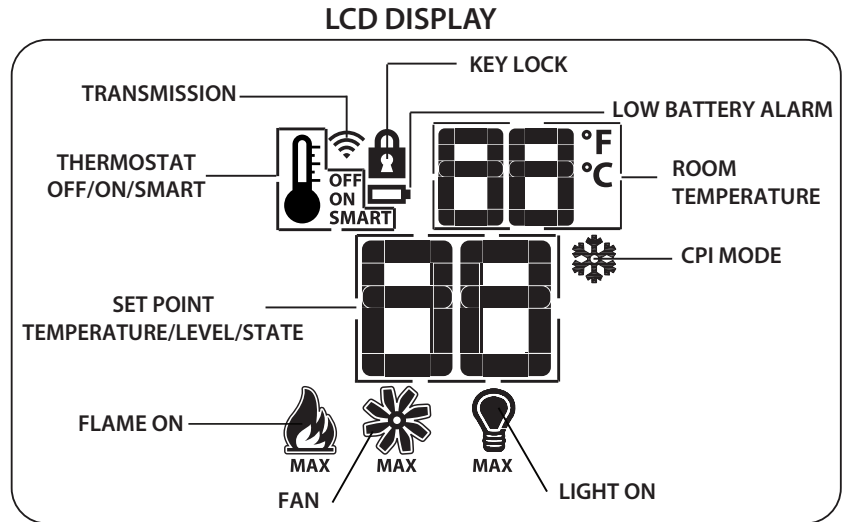
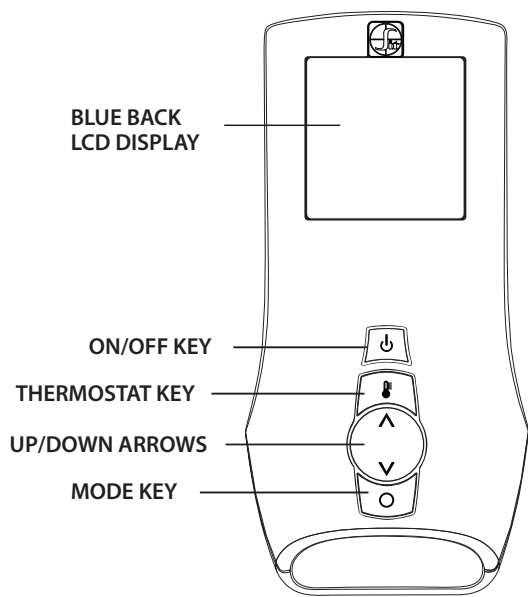

10.9 Remote Control Operation

10.9.1 Temperature Display

1. With the system in the OFF position, simultaneously press the thermostat key and the mode key to change degrees from °F to °C.
2. Visually check the LCD screen to verify either °F or °C is displayed on the right side of the room temperature display.

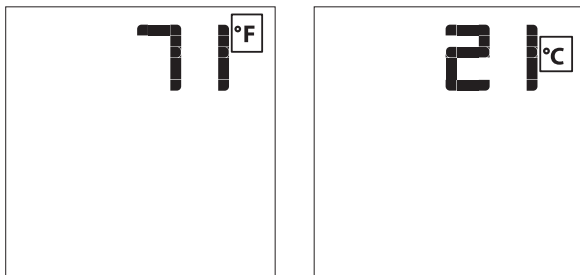

10.9.2 Key Lock

This function locks the keys to avoid unsupervised operation. Once activated, a lock icon will appear on the LCD screen.

1. Simultaneously press the mode key and the up arrow key to activate or deactivate this function.

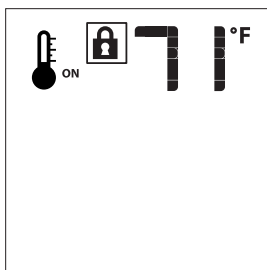

10.9.3 Pilot Ignition Selection (IPI/CPI)

This system has the option of a continuous (standing) pilot. This feature allows the system to change from a spark-to-pilot system to the standing pilot option. The standing pilot will keep the fireplace warm and establish a draft in the vent, which allows the main burner to ignite with less air-flow disruption.

When the system is OFF, the LCD screen will display the snowflake icon during the setup of either IPI or CPI mode. To select the preferred pilot ignition feature,

1. With the system in the OFF position, press the mode key to index the CPI mode icon.
2. Press the up arrow key to activate CPI.
3. Press the down arrow key to return to IPI. A single 'beep' will confirm reception of the command.

When the system is ON,

IPI mode: LCD screen will not display the snowflake icon

CPI mode: LCD screen will display the snowflake icon

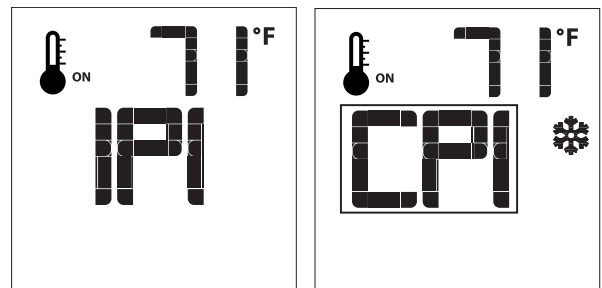

10.9.4 Turn ON the Appliance

1. With the system in the OFF position, press the remote control ON/OFF key to turn ON the appliance.
A single 'beep' will emit from the IFC module to confirm reception of the command.

The LCD screen will display all active icons, and the IFC module will start the ignition sequence.

10.9.5 Turn OFF the appliance

1. With the system in the OFF position, press the remote control ON/OFF key to turn ON the appliance.
A single 'beep' will emit from the IFC module to confirm reception of the command.

The LCD screen will only display the room temperature and its icon, and the IFC module will turn off the main burner.

10.9.6 Remote Control Flame Adjustment

This control system has (6) flame levels. If the smart thermostat operation is activated, then the manual adjustment of the flame height will be disabled.

1. Verify the system is in the ON position and the flame level is set at maximum.
2. Press the down arrow key once to reduce flame height by one level until the flame is turned off.
3. Press the up arrow key once to increase flame height by one step. If the up arrow key is pressed while the system is on, but the flame is off, the flame will ignite on HI.
4. A single 'beep' will confirm reception of the command.



Flame Off

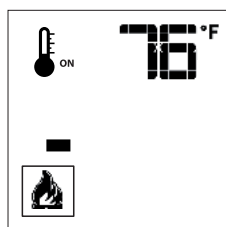

Flame Level 1

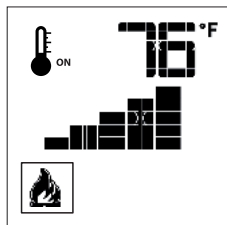

Flame Level 5

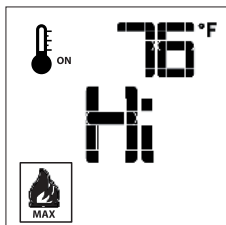

Flame Level Maximum

10.9.6.1 Deactivate Flame Modulation

1. Verify all (3) AAA batteries are installed in the remote control battery bay.
2. Remove (1) AAA battery.
3. Press and hold the on/off key and the mode key at the same time.
4. Reinsert (1) AAA battery.
5. While still holding the on/off key, let go of **ONLY** the mode key.
6. Index over to the flame graphic on the LCD screen to edit. Use the up or down arrow key to choose 'ON' or 'OFF'.



10.9.7 Remote Control Thermostat Operation

10.9.7.1 Room Thermostat

The remote control can operate as a room thermostat. The thermostat can be set to a desired temperature to control a room's comfort level. To activate this function,

1. Press the thermostat key. The LCD screen will display a temperature bulb graphic, the room temperature and set temperature.
2. To adjust the set temperature, press the up or down arrow keys until the desired temperature is displayed on the LCD screen.

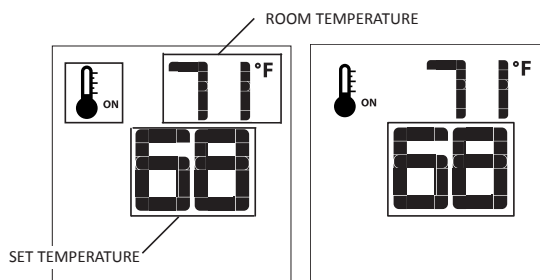

10.9.7.2 Smart Thermostat

The smart thermostat function will adjust the flame height based on the set temperature and the actual room temperature. The smart thermostat function automatically adjusts the flame down when the room temperature reaches the set point. To activate this function,

1. Press the thermostat key until the 'SMART' appears on LCD screen on the right side of the temperature bulb graphic.
2. To adjust the set temperature, press the up or down arrow keys until the desired temperature is displayed on the LCD screen.

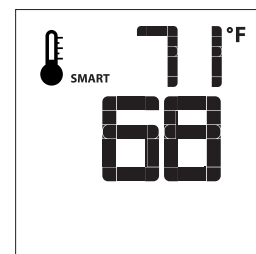
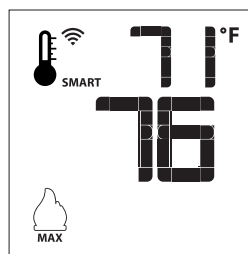

10.9.7.3 Deactivate Remote Control Thermostat Operation

The thermostat operation function can be deactivated. The remote control will still operate the main burner on and off, and function flame, fan, and light modulation. To deactivate this function,

1. Verify all (3) AAA batteries are installed in the remote control.
2. Remove (1) AAA battery.

- While reinserting the battery, push and hold the thermostat key. The temperature bulb graphic will not be displayed on the LCD screen.
- To reactivate remote thermostat operation, follow the same key sequence procedure above. The temperature bulb graphic will reappear on the LCD screen.

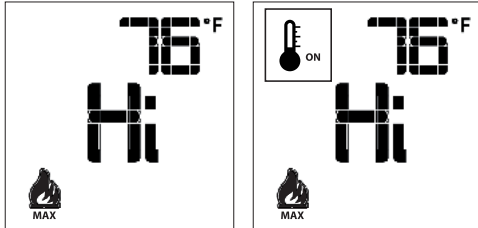

10.9.8 Split Flow Control

The secondary burner is controlled by the split flow. To activate this function,

- Press the mode key to index to the split flow mode icon.
- Press the up arrow key to activate the secondary burner.
- Press the down arrow key to turn the secondary burner off. A single 'beep' will confirm the reception of the command.

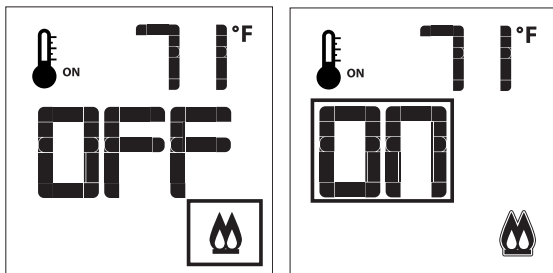

10.9.9 Fan Speed Control (optional)

Fan speed can be adjusted through (6) speeds. To activate this function,

- Press the mode key to index to the fan control icon.
- Press the up or down arrow keys to turn on, off, or to adjust fan speed.

Thermostat mode: Fan(s) have a (5) minute delay time when the fireplace is lit. This allows time for heat to build in fireplace before fan operation. The fan will continue to operate for approximately (12) minutes after the fireplace has been turned off.

Manual mode: Fan(s) will operate at previous setting. There is no delay in start up or stop time.

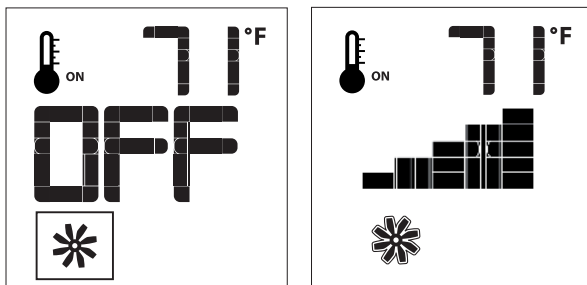

10.9.10 Accent Light Kit (if applicable)

The light intensity can be adjusted through (6) levels.

- Press the mode key to index to the light icon.

- Press the up or down arrow keys to adjust the intensity level.
- A single 'beep' will confirm reception of the command.

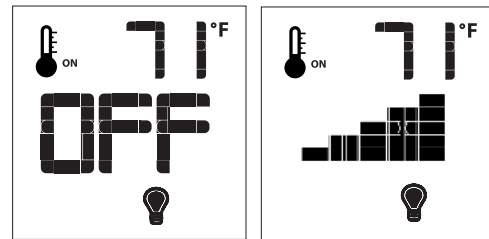

10.9.10.1 Deactivate Light Kit Modulation

- Verify all (3) AAA batteries are installed in the remote control battery bay.
- Remove (1) AAA battery.
- Press and hold the on/off key and the mode key at the same time.
- Reinsert (1) AAA battery.
- While still holding the on/off key, let go of **ONLY** the mode key.
- Index over to the bulb graphic on the LCD screen to edit. Use the up or down arrow key to choose 'SET' or 'CLR'.



10.9.11 Remote Control Low Battery Detection

Remote control battery lifespan depends on various factors including battery quality, number of ignitions, changes to room thermostat set point, etcetera.

- When the remote control battery are low, a battery icon will appear on the LCD display before all battery power is lost.
- When the batteries are replaced, this icon will disappear.

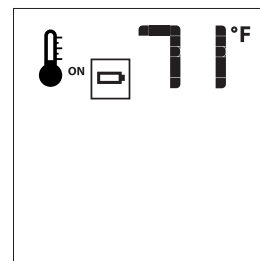

11.0 ADJUSTMENT

11.1 Pressure Testing

NOTE: The appliance and its appliance main gas valve must be disconnected from the gas supply piping system during any pressure testing of the system at test pressures in excess of ½ psi (3.5 kPa).

IMPORTANT: Pressure check taps for manifold (outgoing) and inlet (incoming) pressure have been incorporated into the valve. The pressure tap marked OUT measures outgoing pressure. The pressure tap marked IN measures incoming pressure.

11.1.1 Inlet Pressure Test

NOTE: Make sure to apply these incoming pressure test with all other gas appliances on, or at full capacity in the house for proper pressure reading.

IMPORTANT: If the inlet pressure reading is too high or too low, contact the gas company. Only a qualified gas service technician should adjust incoming gas pressure.

1. Loosen the inlet (IN) pressure tap by turning screw counter-clockwise. See (A) in Figure 11.1.
2. Attach manometer using a ¼" (6mm) I.D. hose.
3. Light pilot and burner. Check pressure to ensure it is between the minimum and maximum recommended pressure settings.
4. Turn off burner and pilot.
5. Disconnect hose and tighten the inlet (IN) pressure tap by turning screw clockwise. Screw should be snug. Do not over tighten.
6. Relight pilot and burner. Then reattach manometer to the inlet pressure tap (A) to verify the tap is completely sealed. Manometer should read no pressure.

11.1.2 Manifold Pressure Test

1. Light pilot.
2. Loosen manifold (OUT) pressure tap by turning screw counter-clockwise. See (B) in Figure 11.1.
3. Attach manometer to pressure tap using a ¼" (6mm) I.D. hose.
4. Light burner. Check manometer reading.
5. Turn burner and pilot off.
6. Disconnect manometer hose and tighten the manifold (OUT) pressure tap by turning screw clockwise. Screw should be snug. Do not over tighten.
7. Attach the manometer to the manifold pressure tap (B) to verify it is completely sealed. The manometer should read no pressure when pilot and burner are on.

Table 11.1, Inlet Pressures

Fuel	Natural Gas	Propane
Gas Supply	Min - Max	Min - Max
Inlet Pressure Tap (A)	5" - 10.5" WC (1.25 - 2.62 kPa)	12" - 13" WC (2.99 - 3.24 kPa)

Table 11.2, Manifold Pressure

Fuel	Natural Gas	Propane
Gas Supply	Low - High	Low - High
Manifold Pressure Tap (B)	1.1" - 3.8" WC (.27 - .95 kPa)	2.9" - 11" WC (.72 - 2.74 kPa)

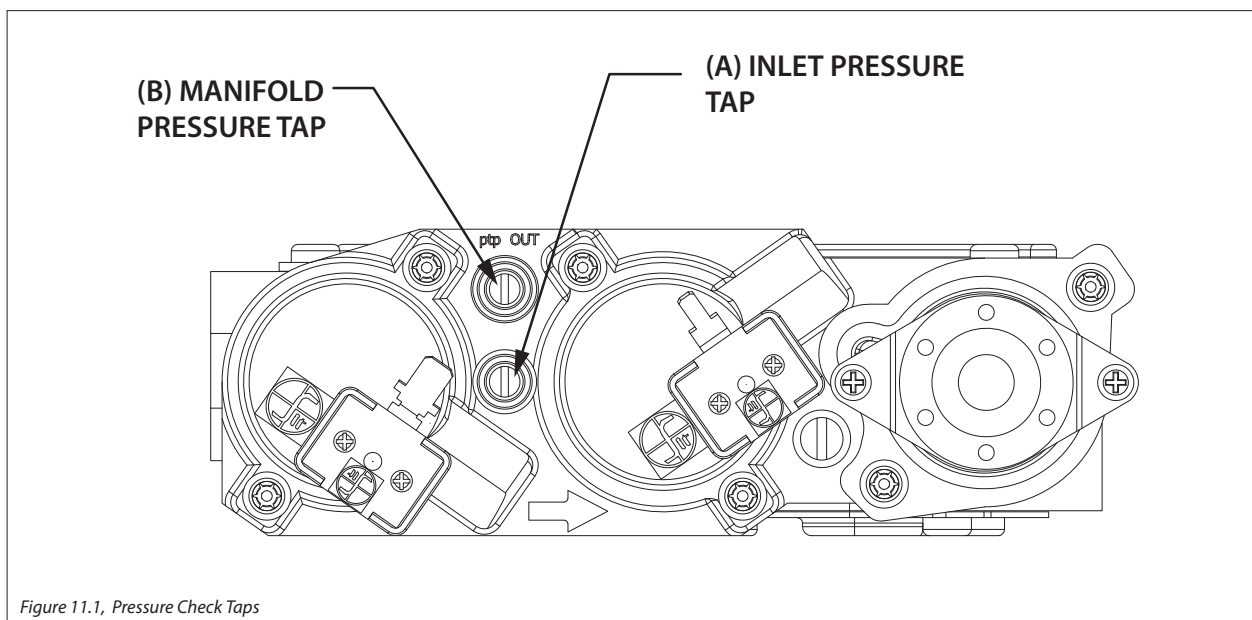

Figure 11.1, Pressure Check Taps

11.2 Burner Flame Adjustments

WARNING: To avoid property damage or personal injury, allow the fireplace ample time to cool before making any adjustments.

Burner flame appearance and characteristics are affected by altitude, fuel quality, venting configuration, and other factors. After installation, this appliance may need additional adjustments to achieve optimum flame appearance and visual aesthetics.

11.2.1 Burner Venturi

WARNING: VENTURI ADJUSTMENT MUST BE DONE BY A QUALIFIED SERVICE TECHNICIAN.

NOTE: Burner venturi air shutter settings have been factory set. Refer to Table 11.3.

When this appliance is first lit, the burner flames will appear blue. During the first 15 minutes of operation, flame appearance will gradually turn to the desired yellow appearance. If the flames remain blue, or become dark orange with evidence of sooting (black tips), adjustment of the air shutter opening may be necessary.

Regardless of venturi orientation, closing the air shutter will achieve a desired yellow flame, but may produce soot on the glass. Opening the air shutter will cause a short, blue flame that may lift off the burner.

The air shutter on this appliance is factory set for horizontal terminations, and may need adjustment for natural gas installations, depending on venting length and configuration. Hussong Mfg. Co., Inc. recommends natural gas venting installation with at least 4' (1219mm) of vertical height to adjust the air shutter openings as outlined in Table 11.4.

Fuel	Front	Rear
Natural Gas	1/8" (3mm) open	1/8" (3mm) open
Propane	7/16" (11mm) open	5/16" (8mm) open

Fuel	Front	Rear
Natural Gas	1/8" (3mm) open	Closed

11.2.1.1 Venturi Adjustment

NOTE: If soot is present on the glass, check glass media placement before adjusting the venturi.

1. Remove the safety barrier, glass frame assembly, and log set.
2. Remove the front burner from the firebox (2) screws.
3. Remove the back burner tube.
4. Loosen screw on venturis and adjust as necessary. Tighten screw.
5. Reinstall all components previously removed.

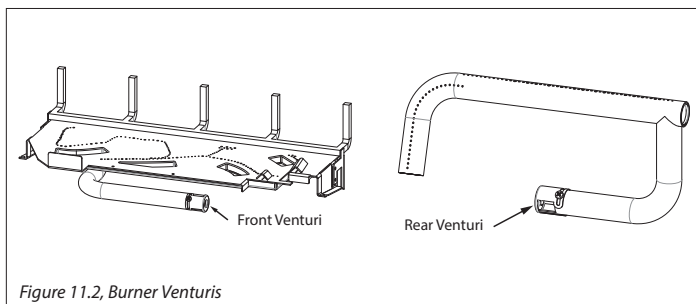

Figure 11.2, Burner Venturis

IMPORTANT: Slight adjustments to the venturi opening will create dramatic results. Adjust at slight increments until desired look is achieved. Always burn the fireplace for at least 15 minutes, and allow the appliance ample time to cool before making any further adjustments.

Use Table 11.5 and Figure 11.3 below for guidelines to achieve desired flame appearance.

Flame Characteristic	Cause	Solution
Dark, orange flame with black tips	Venturi closed too far	Open venturi slightly
Short, blue flames	Venturi open too far	Close setting slightly
Lifting (ghosting) flames	Gas pressure too high Venturi closed too far	Check manometer settings Open venturi setting slightly

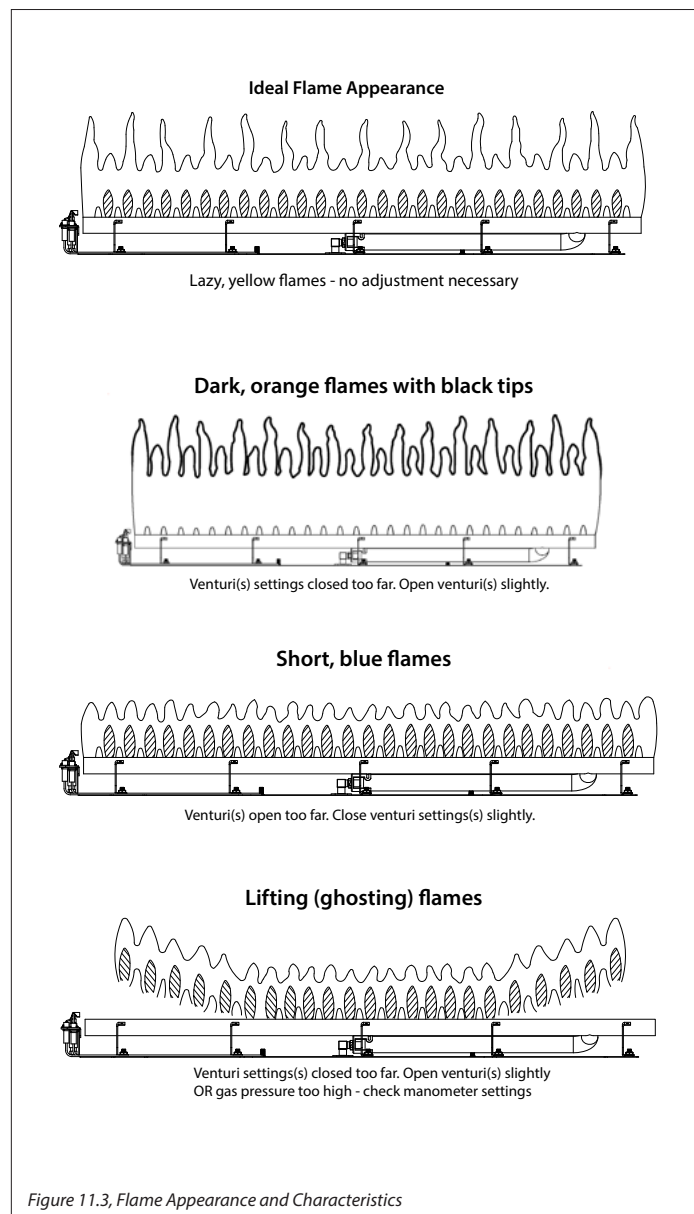

Figure 11.3, Flame Appearance and Characteristics

11.2.2 Vent Restriction (after installation)

WARNING: To avoid property damage or personal injury, allow the fireplace ample time to cool before making any adjustments.

WARNING: Improper vent installation may cause the burner flames to lift or “ghost.” Perform a visual check on flame appearance after restriction adjustment to ensure proper performance.

Vertical terminations may display an active, compact flame. If this appearance is not desirable, a restrictor plate may need to be installed or modified after vent termination installation. Access to the vent exit for restriction can be reached through the fireplace baffle. Allow the fireplace to burn for 15 minutes before making any adjustments.

Flame Appearance	Draft Problem	Solution
Short, flickering	Excessive draft Not enough restriction	Close baffle restrictor
		Add restrictor plate
Lifting or ghosting*	Insufficient draft	Open baffle restrictor
		Remove inner ring(s) on restrictor plate, or Remove restrictor plate
*If flames continue to lift or ghost after opening the restrictor and verifying correct vent installation, shut off the gas supply and call a qualified service technician.		

11.2.2.1 Baffle Restrictor Adjustment

NOTE: Verify the baffle door restrictor is set into ‘down’ position and not flipped ‘up.’

1. Remove the safety barrier and glass frame assembly to access the baffle restrictor adjustment handle.
2. Loosen (2) thumb screws to adjust the setting to achieve desired flame appearance.
3. Tighten screws after adjustment.
4. Reinstall the glass frame assembly and safety barrier.

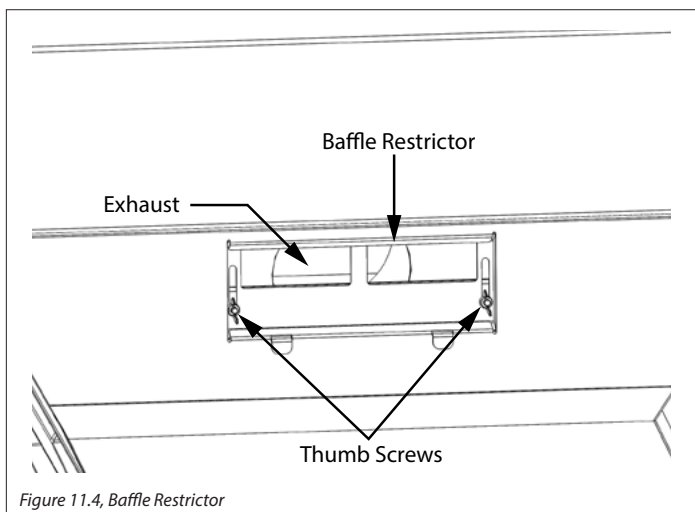

Figure 11.4, Baffle Restrictor

11.2.2.2 Restrictor Plate Installation

1. Remove the safety barrier and the glass frame assembly.
2. To access the vent exit through the fireplace baffle, push baffle restrictor back.
3. Bend the tabs on the restrictor plate (included in components packet) to approximately 80° angles. This will create tension when the restrictor is inserted into the exhaust pipe.
4. Insert restrictor into the 5" (127mm) exhaust pipe with the tabs pointing towards you.
5. Set the baffle restrictor back into position.
6. Reinstall all components previously removed.

11.2.2.3 Restrictor Plate Modification

1. Remove the safety barrier and the glass frame assembly.
2. To access the vent exit through the fireplace baffle, push baffle restrictor back.
3. Remove the restrictor by pulling it down and out of the 5" (127mm) exhaust pipe.
4. Make necessary modifications to achieve desired flame appearance.
5. Insert restrictor into the 5" (127mm) exhaust pipe with the tabs pointing towards you.
6. Set the baffle restrictor back into position.
7. Reinstall all components previously removed.

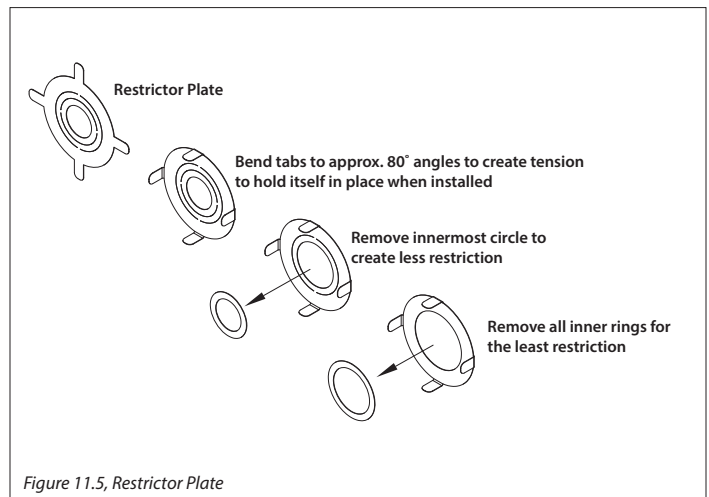

Figure 11.5, Restrictor Plate

12.0 TROUBLESHOOTING

ATTENTION: Troubleshooting must be performed by a qualified technician.

Before proceeding with the steps in the following troubleshooting guide,

- Verify proper 120VAC power supply to the control module.
- Verify the control module battery pack and the remote control batteries are fresh and installed with correct polarity.
- Verify all connections between the wire harnesses and the system components are proper and positive.
- Verify the communication link is established between the remote control and the IFC module.
- Verify inlet pressure meets the recommended inlet pressure. If necessary, adjust line pressure regulator.

Issue	Cause	Solution
Pilot will not light	Electrical power interrupted or disconnected	Restore electrical power to appliance or use battery back-up.
	Wiring disconnection	Ensure batteries are fully charged if using battery back-up as power source. Use wiring schematic in this manual to determine that all wiring connections are secure and correct.
	Gas supply turned off	Check remote shut-off valves from the appliance. Usually there is a valve near the main gas line. There may be more than (1) valve between the appliance and main gas line.
Pilot will not stay lit	No propane in tank	Check propane tank. Refill if necessary.
	Low gas pressure	Consult a plumber or a gas supplier. Can be caused by situations such as a bent line, too narrow diameter or pipe, or a low line pressure.
	Pilot flame not making contact with the flame rectification sensor on the pilot assembly	Verify the pilot flame envelopes the top of the flame sensor and extends far enough onto burner for ignition. To adjust pilot flame, turn pilot adjustment screw on the gas valve clockwise to decrease flame, and counterclockwise to increase flame.
	Pilot adjustment screw not sealed	Seal pilot adjustment screw. Do not over-tighten.
Pilot flame always on, or will not extinguish	Control system set to CPI mode	Set control system to IPI mode.
Main burner flame will not light	ON/OFF rocker switch in OFF position	Switch rocker switch to ON position.
	Gas supply turned off	Check for multiple shut-offs in the supply line. Verify gas supply is turned on.
	Low gas supply	Consult with plumber or gas supplier. Check propane tank. Refill if necessary.
	Wiring disconnection or improper wiring	Check for faulty or incorrect wiring.
	Plugged main burner orifice	Remove blockage.
	Pilot flame	Verify the pilot flame is properly directed to ignite burner. See pilot flame troubleshooting above.
	Remote control not working properly	Replace batteries.
	No call for heat	Verify remote control is powered ON and thermostat operation is turned OFF.

Issue	Cause	Solution
Pilot and burner extinguish while in operation	No propane in tank	Check propane tank. Refill if necessary.
	Incorrect glass assembly installation	Refer to Section 8.1 Glass Frame Assembly on page 35.
	Incorrect vent cap installation	Adjust if necessary.
	Vent cap blockage	Remove debris if necessary.
	Improper pitch on horizontal venting	¼" (6mm) rise per foot (30cm) is required on horizontal venting
	Exhaust vent pipe leaking exhaust gases back into firebox	Check for leaks and repair if necessary.
	Excessive draft	A restrictor may need to be installed or modified. Refer to Section 11.2.2 Vent Restriction (after installation) on page 47.
Soot appears on glass	Improper log placement	Section 8.3 #C39-50B Log Set Installation on page 36.
	Improper venturi setting	Venturi air shutter may need to be opened slightly to allow more air into the gas mix. Refer to Section 11.2.1 Burner Venturi on page 46.
	Incorrect vent cap installation	Adjust if necessary.
	Vent cap blockage	Remove debris if necessary.
Flame burns blue and lifts off burner	Improper venturi setting	Venturi air shutter may need to be opened slightly to allow more air into the gas mix. Refer to Section 11.2.1 Burner Venturi on page 46.
	Incorrect vent cap installation	Adjust if necessary.
	Blockage or leakage of the vent system	Check the vent pipes for leaks, and the vent cap for debris. Repair the vent pipes or remove debris from vent cap, if necessary.
No reaction to command	Battery back batteries or remote control batteries low	Replace batteries.
	No communication between remote control and IFC module	Reprogram remote control to IFC module.
	A maximum number of failed ignitions or flame restorations has been reached	Reset IFC module.

13.0 MAINTENANCE

ATTENTION: Installation and repair should only be done by a qualified service person. The appliance should be inspected before use and at least annually by a professional service person. More frequent cleaning might be required due to excessive lint from carpeting, bedding material, et cetera. It is imperative that control compartments, burners, and circulating air passageways of the appliance be kept clean. Use a vacuum to clean all components.

WARNING: The appliance area must be kept clear and free from combustible materials, gasoline and other flammable vapors and liquids.

13.1 Firebox

Performed by: Qualified Service Person

Frequency: Annually

Action:

- Vacuum and clean any debris in the firebox that is not supposed to be there.
- Inspect and operate the bottom latch assembly. Verify the assembly is free from obstruction to operate. The handles must have spring tension but be able to move forward freely.

13.2 Fan

CAUTION: Label all wires prior to disconnection when servicing controls. Wiring errors can cause improper and dangerous operation. Verify proper operation after servicing.

Performed by: Qualified Service Person

Frequency: Every 6 months

Action:

- Disconnect the fan from electrical current and vacuum.
- The bearings are sealed and require no oiling.

13.3 Vent System

NOTE: If the vent-air intake system is disassembled for any reason, reinstall per instructions provided with installation. Refer to Section 7.0 Venting on page 28.

Performed by: Qualified Service Person

Frequency: Annually

Action:

- Examination of the vent system is required.
- The flow of combustion and ventilation air must not be obstructed.

13.4 Glass Assembly

CAUTION: Do not operate appliance with the glass assembly removed, cracked, or broken. Use protective gloves to handle any broken or damaged glass assembly components.

WARNING: Do not use substitute materials.

WARNING: Avoid striking or slamming glass assembly. Avoid abrasive cleaner. DO NOT clean glass while it is hot.

IMPORTANT: Any safety screen, guard, or barrier removed for servicing the appliance must be replaced prior to operating the appliance.

Performed by: Homeowner

Frequency: Annually

Action:

- Prepare a work area large enough to accommodate the glass assembly on a flat, stable surface.
- Remove safety screen and glass frame assembly.
- Clean glass window with a suitable fireplace glass cleaner using a soft cloth. Abrasive cleaners must not be used. Be careful not to scratch the glass when cleaning.
- Reinstall glass assembly and safety screen. Do not operate fireplace without safety screen.

Performed by: Qualified Service Person

Frequency: Annually

Action:

- Clean glass window with a suitable fireplace glass cleaner using a soft cloth. Abrasive cleaners must not be used. Be careful not to scratch the glass when cleaning.
- Inspect the glass for cracks, scratches, and nicks.
- Verify the glass assembly is properly intact and not damaged.
- Replace the glass and the assembly #701-007T as necessary.
- Only Hussong Mfg. Co., Inc. will supply the replacement of glass assembly as a complete unit.

13.5 Burner and Pilot System

The burner assembly may be removed for easier access to the control compartment. Refer to Section 8.4 Control Board Removal and Installation on page 37 for instructions. Verify gas supply is turned on and filled. Consult with plumber or gas supplier as necessary.

Performed by: Qualified Service Person

Frequency: Annually

Action:

- Vacuum all components of the burner system.
- Check all accessible gas-carrying tubes, connections, pipes and other components for leaks.
- Inspect the operation of the flame safety system Pilot or Flame rectification device. Visually check pilot light when in operation.
- Inspect and ensure the lighting of the main burner occurs within (4) seconds of the main gas valve opening. Check for faulty or incorrect wiring and correct or replace as necessary. Inspect primary air openings (burner ports) for blockage, especially near the pilot.
- Visually check burner flame pattern when in operation. Flames should be steady, not lifting or floating.
- Test and measure the flame failure response time of the flame safety system. It must de-energize the safety shutoff in no more than (30) seconds.

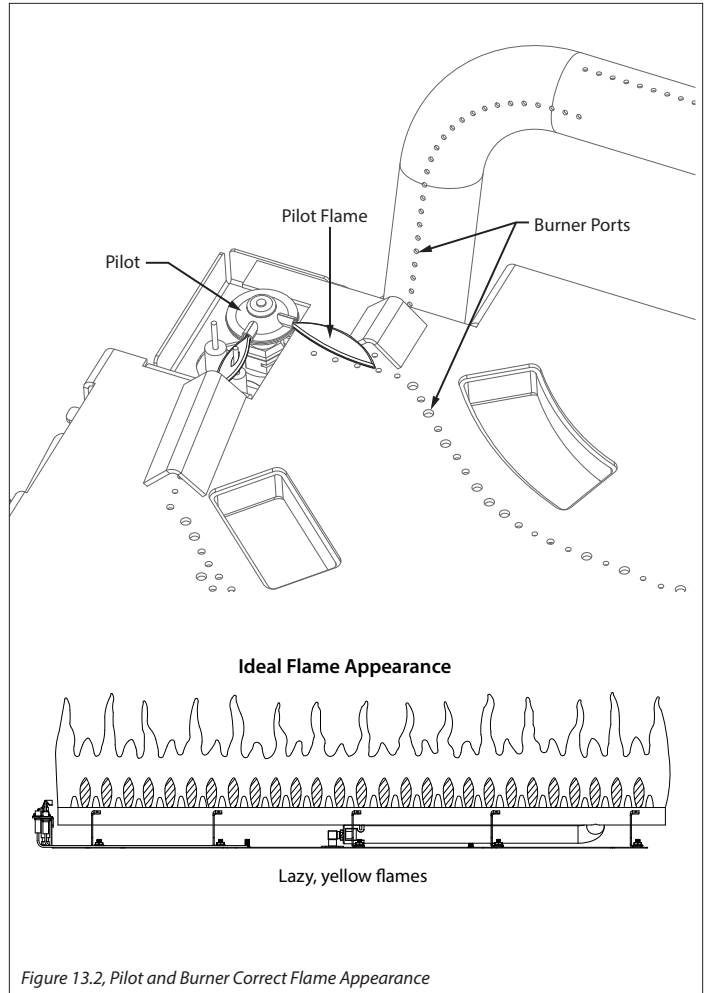
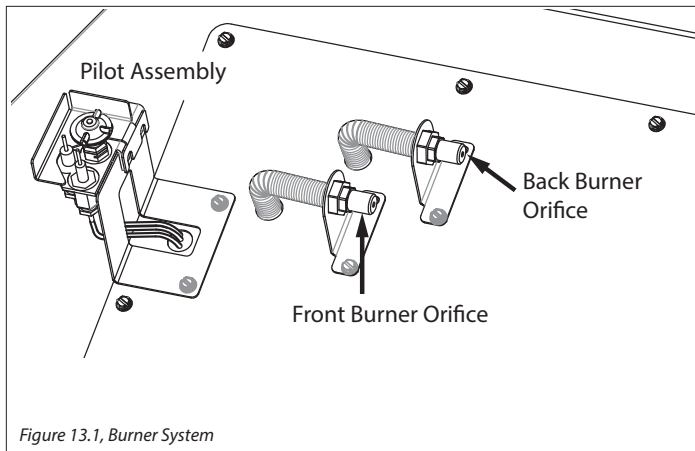

14.0 REPLACEMENT PARTS LIST

Replacement parts are available through your local dealer. Contact your local dealer for availability and pricing.

The following warning is for replacement parts for this appliance.

WARNING: This product can expose you to chemicals including Lead, which is [are] known to the State of California to cause cancer, birth defects or other reproductive harm. For more information, visit www.P65Warnings.ca.gov.

CAR-39 CONTROL BOARD AND PARTS			
Control Board - NG	C39-160A-7	Valve Step Motor - Propane	700-504-1
Control Board - Propane	C39-161A-7	18" Flexible Gas Line - Black	700-213B
SIT IPI Gas Valve - NG	700-567	Flexible Gas Line - Valve to Burner Connection	700-226F
SIT IPI Gas Valve - Propane	700-567-1	NG Burner Orifice #44 FRONT	700-244
Proflame 2 IFC Board	700-652-7	NG Burner Orifice #47 BACK	700-247
IFC Wire Harness Assembly	700-653	Propane Burner Orifice #55 FRONT	700-255
Pilot Assembly - NG	700-551	Propane Burner Orifice #56 BACK	700-256
Pilot Assembly - Propane	700-551-1	Conversion Kit - NG	NCK-C39-SB
540 Split Flow	700-604	Conversion Kit - Propane	LCK-C39-SB
Transmitter (Remote Control) with Split flow	700-508	Burner Tube	C39-035A
Pilot Orifice - NG #62	700-166	Burner Plate (Front)	C39-350A
Pilot Orifice - Propane #35	700-168	Log Plate with Burner Bracket (Rear)	C39-351A
Valve Step Motor - NG	700-504		

GLASS AND GLASS PARTS	
28-5/8" x 34-1/2" - Glass with Gasket	701-007T
1-1/8" Glass Gasket	900-006
Replacement Valance	C39-005

SAFETY BARRIERS	
Full Rectangular Screen Front	C39-FRSF
Prairie Screen Front	C39-PSF
Rectangle Screen Front	C39-RSF2
Arched Mission Screen Front	C39A-MSF
Arched Full Prairie Door Screen Front	C39A-FPDSF2
Rectangular Mission Screen Front	C39R-MSF

FAN KIT	
Fan Assembly	IPI-075

LIGHT KIT	
Light Kit	C39-LKT
20W 120V Halogen Bulb	600-676
1.5 lb (0.68kg) Ember Panel Crushed Glass	600-697

LOG SET	
13 Piece Log Set	C39-50B
Ember Panel	C39-900E
#C39 1B Log	C39-1B
#C39 2B Log	C39-2B
#C39 3B Log	C39-3B
#C39 4B Log	C39-4B
#C39 5B Log	C39-5B
#C39 6B Log	C39-6B
#C39 7B Log	C39-7B
#C39 8B Log	C39-8B
#C39 9B Log	C39-9B
#C39 10B Log	C39-10B
#C39 11B Log	C39-11B
#C39 12B Log	C39-12B
#C39 13B Log	C39-13B
Rock Wool Embers	900-REMB

ADDITIONAL COMPONENTS	
5" (127mm) Restrictor Plate	900-086
Manual Gas Shut-off Valve	700-203
Vent Heat Shield Assembly	C39-HHS

Hussong Manufacturing Co., Inc.
P.O. Box 577
204 Industrial Park Drive
Lakefield, MN 56150-0577
USA

CAR-39

LIMITED LIFETIME WARRANTY

Warranty Coverage

Hussong Manufacturing Company, Inc. (Hussong Mfg.) warrants this Kozy Heat gas appliance from the date of purchase to the original purchaser, that it is free of defects in materials and workmanship at the time of manufacture. Registering your fireplace warranty does not require any documents to be sent in to Hussong Mfg. Please retain your proof of purchase reflecting the date of purchase along with the serial number and model of your fireplace for any future warranty claims.

If a defect is noted within the warranty period, the customer should contact their authorized dealer for service within 30 days.

30 Days: Parts & Labor*

- Paint
- Light bulbs
- Gasket material
- Glass media and media dam

Year 1: Parts & Labor*

- All parts and material except the items listed in the 30 day warranty and any exclusions or limitations that may apply.
- *Hussong Mfg. will issue labor reimbursement to an authorized dealer only. Hussong Mfg. will not be liable for charges occurred as a result of any service performed by a non-authorized service provider, without pre-authorization.*

Years 2 through Lifetime: Parts Only

- Firebox
- Heat Exchanger
- Logs
- Burner tube or pan
- Outer shell
- Heat shield(s)
- Front Viewing Glass (thermal shock only)
- Refractory Firebox liner (excluding enamel and glass panels)

EXCLUSIONS AND LIMITATIONS

1. This appliance must be installed by a licensed, authorized service technician or contractor. It must be installed, operated and maintained at all times in accordance with the instructions in the owner's manual or the warranty is void.
2. This warranty is nontransferable and is made to the original purchaser only.
3. This warranty excludes standard wear and tear of the appliance which is considered normal usage over time.
4. Discoloration and some minor expansion, contraction or movement of certain parts, resulting in noise, is normal and not a defect.
5. Warranty is automatically voided if the appliance's serial number and/or testing label is removed or if the appliance is altered or tampered with in any way.
6. Warranty is void if the appliance is subject to submersion in water or prolonged periods of dampness or condensation. Any damage to any part of the appliance due to water or weather damage which is the result of, but not limited to, improper chimney/venting installation will also render this warranty void.
7. This warranty does not cover installation and operational related problems such as environmental conditions, nearby trees, buildings, hilltops, mountains, inadequate venting or ventilation, excessive offsets, negative air pressures caused by any mechanical systems.
8. Chimney components and other Non-Hussong Mfg. accessories used in conjunction with the installation of this appliance are not covered under this warranty.
9. Damage to plated surfaces or accessories, if applicable, caused by scratches, fingerprints, melted items or other external sources left on the surfaces from the use of cleaners is not covered under this warranty.
10. It is expressly agreed and understood that this warranty is Hussong Mfg.'s sole obligation and purchaser's exclusive remedy for defective fireplace equipment. Hussong Mfg. is free of liability for any damages caused by this appliance, as well as inconvenience expenses and materials. Incidental or consequential damages are not covered by this warranty. In some states, the exclusion of incidental or consequential damage may not apply. Hussong Mfg. shall not be held to implied warranties and this warranty shall replace all previous warranties.
11. This limited lifetime warranty is the only warranty supplied by Hussong Mfg. Any warranties extended to the purchaser by the dealer/distributor, whether expressed or implied, are hereby disclaimed and the purchaser's recourse is expressly limited to the warranties set forth herein.
12. Any part repaired or replaced during the limited warranty period will be warranted under the terms of the limited warranty for a period not to exceed the remaining term of the original limited warranty.
13. Any replacement part repaired after the warranty period will include a 90 day parts coverage
14. Hussong Mfg. may require the defective part to be returned using a pre-authorized RGA number or a photo of the defective component. Failure to provide either can result in a denied claim.
15. This warranty does not cover the appliances ability to heat a desired space, as there are many factors that can impact the heating performance in each home. Consideration should be implied to the appliance's location, room size, home design, environmental conditions, insulation, and tightness of the home.
16. Hussong Mfg. reserves the right to make changes at any time, without notice, in design, material, specifications, and prices. Hussong Mfg. reserves the right to discontinue models and products.

