

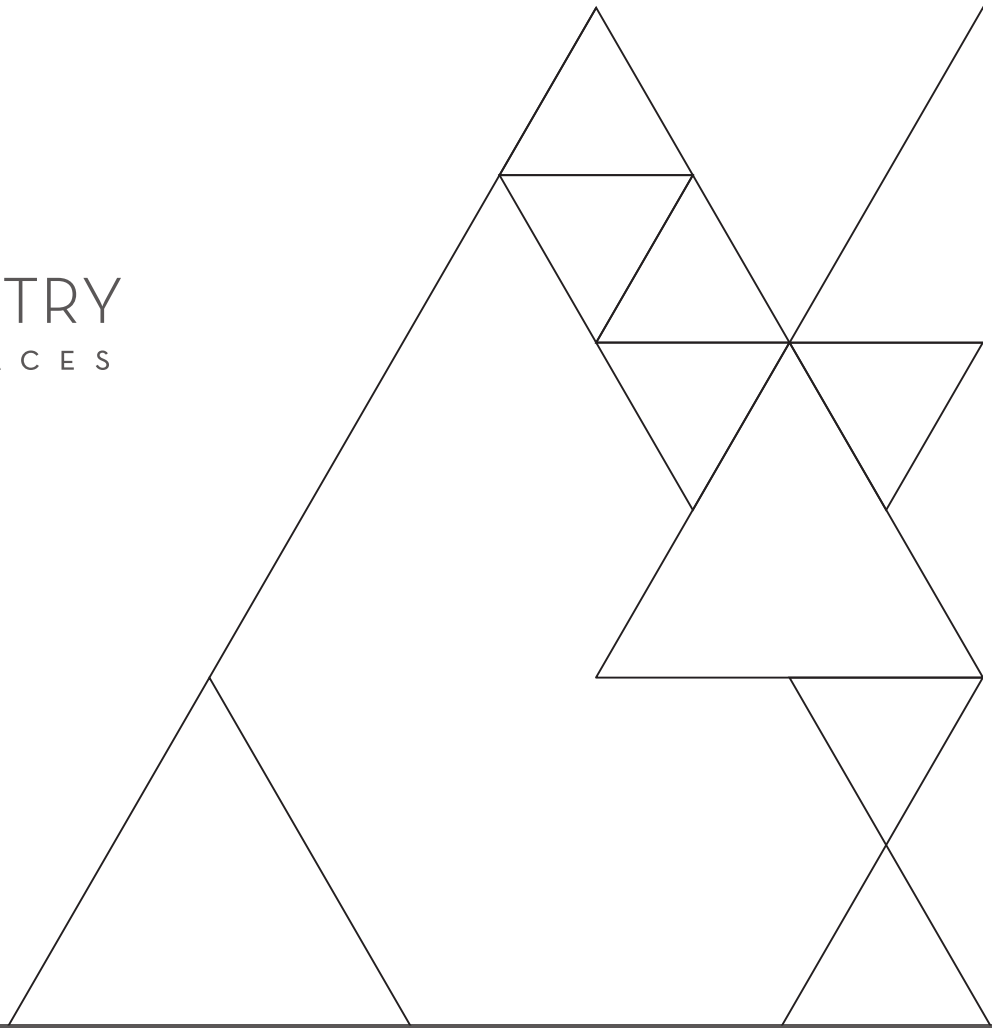

TOWN & COUNTRY
LUXURY FIREPLACES



FOR ARCHITECTS & DESIGNERS

TC36

SERIES D2

Dimensions | Clearances | Venting

IMPORTANT

This booklet is intended as a basic specification guide for architects, designers and builders. Please refer to the Instruction Manual supplied with the fireplace for detailed information regarding installation and operation.

Product installation manuals can also be viewed at:
www.townandcountryfireplaces.com

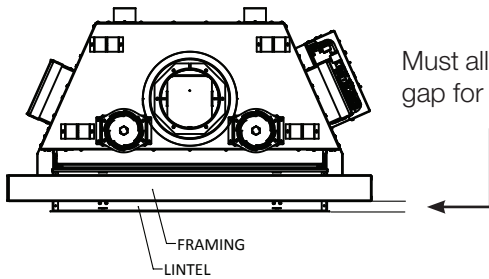
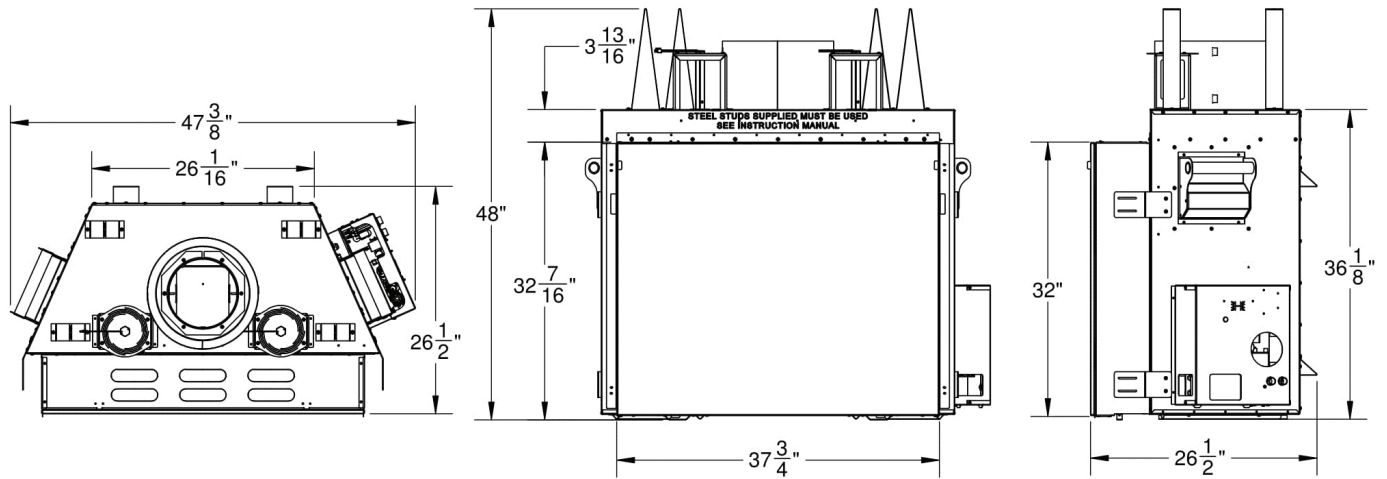

Must allow for minimum 1/2 inch gap for non-combustible board.



TC36D2 Cad Drawing
Available at
www.townandcountryfireplaces.com

Examples of Common Locations

See minimum combustible framing dimensions section on page 4 for precise framing dimensions

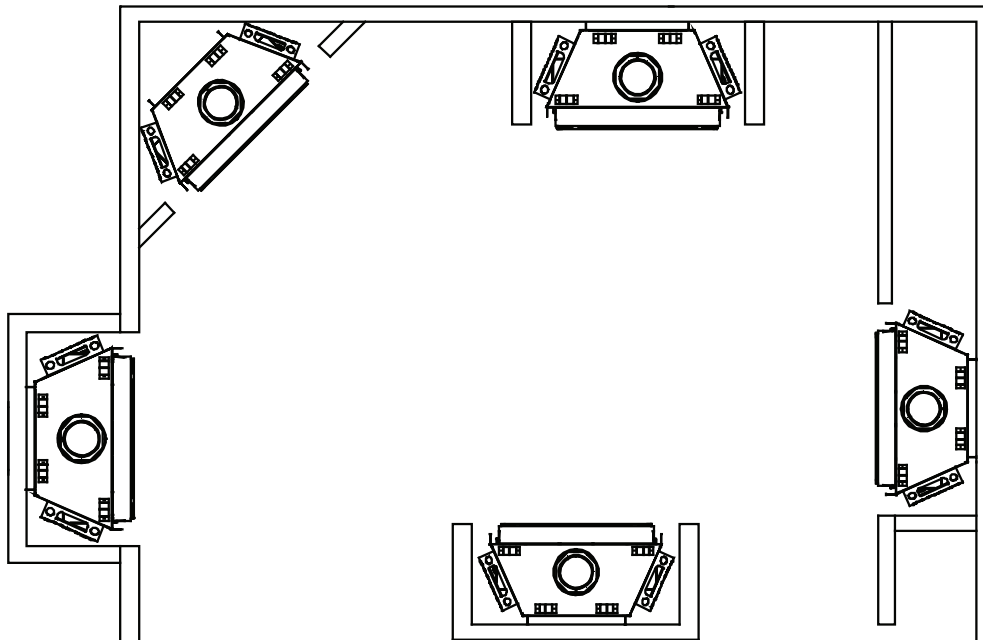

FOR REFERENCE ONLY. CONSULT MANUAL BEFORE INSTALLATION

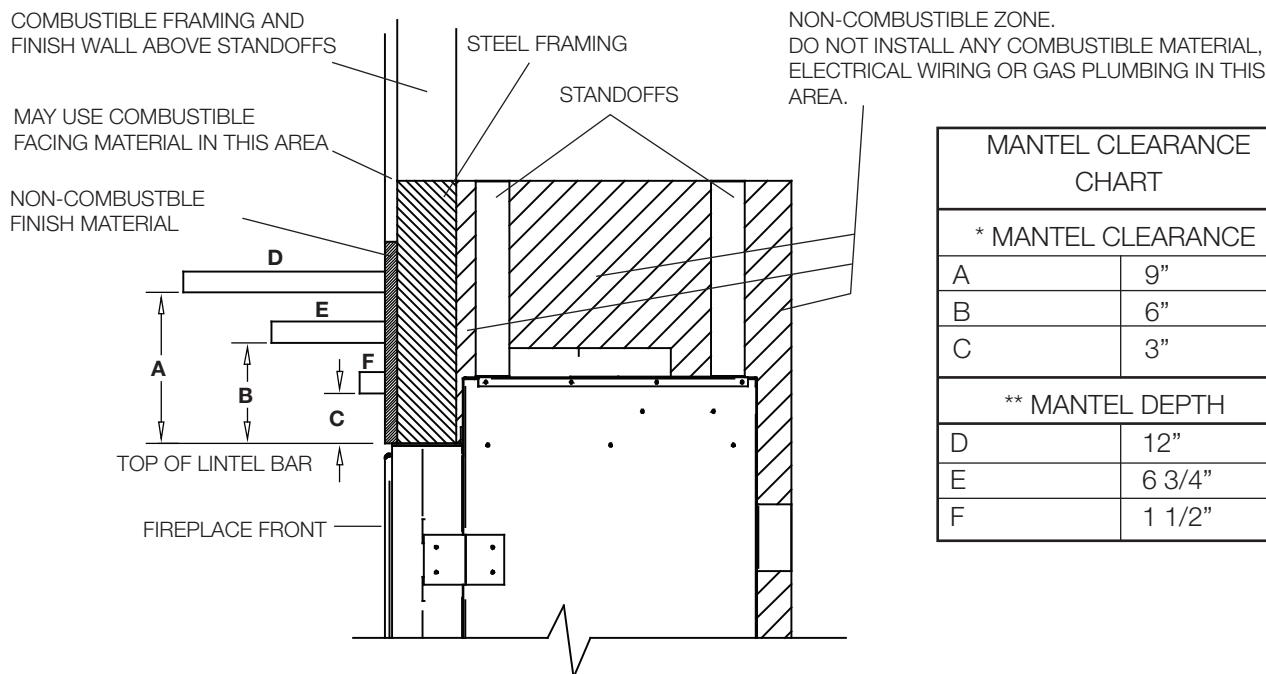

MANTEL CLEARANCE CHART	
* MANTEL CLEARANCE	
A	9"
B	6"
C	3"
** MANTEL DEPTH	
D	12"
E	6 3/4"
F	1 1/2"

Minimum Clearances to Combustibles

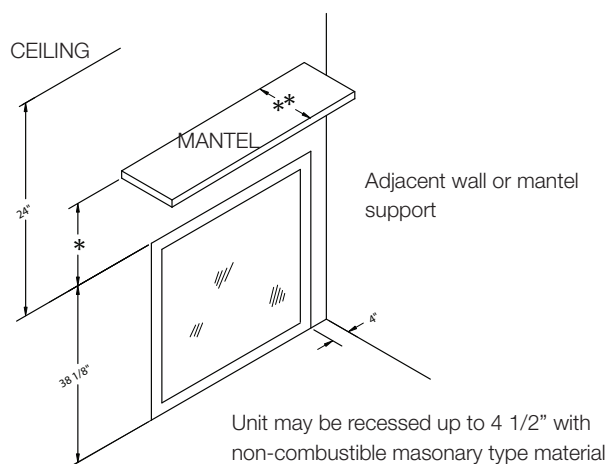

Minimum Clearances:

Side standoffs	0 in.	(0 mm)
Back standoffs	0 in.	(0 mm)
Top standoffs.....	0 in.	(0 mm)
Bottom of appliance	0 in.	(0 mm)
Adjacent side wall.....	4 in.	(102 mm)
Ceiling to appliance	24 in.	(610 mm)
*Mantel to appliance.....	See figure and table above	
**Maximum Mantel extension.....	See figure and table above	
Mantel support	4 in.	(102 mm)
Vertical vent pipe	1 3/4" in.	(45 mm)
Horizontal Vent pipe (Top, sides and bottom).....	1 3/4" in.	(45 mm)

Framing kit is supplied with Fireplace

All other framing can be done with conventional lumber

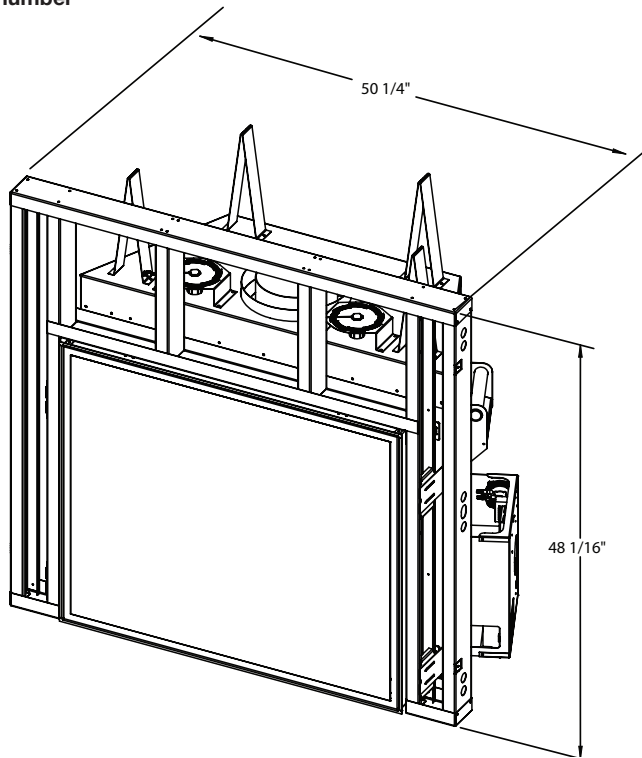

Non-combustible Board Detail

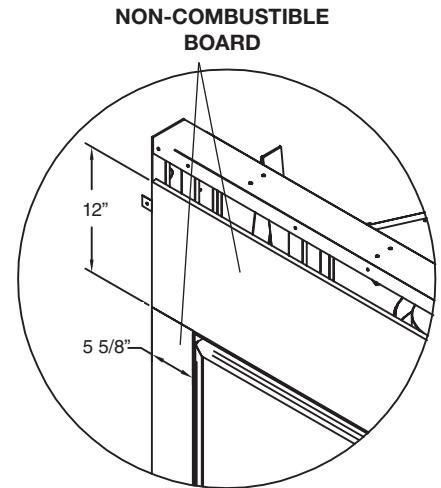

NON-COMBUSTIBLE materials must extend 12" above and 5 5/8" to the sides of the framing edges.

NON-COMBUSTIBLE BOARD NOT INCLUDED.

Minimum Combustible Framing Dimensions

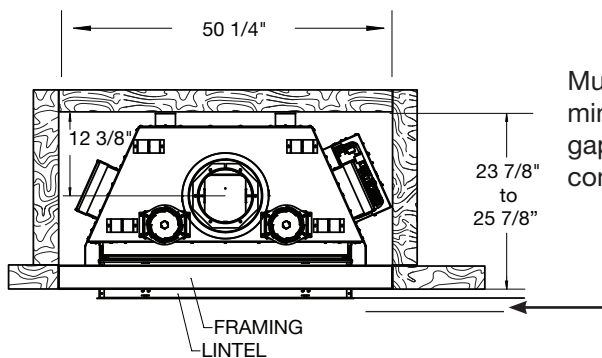

Must allow for minimum 1/2 inch gap for non-combustible board.

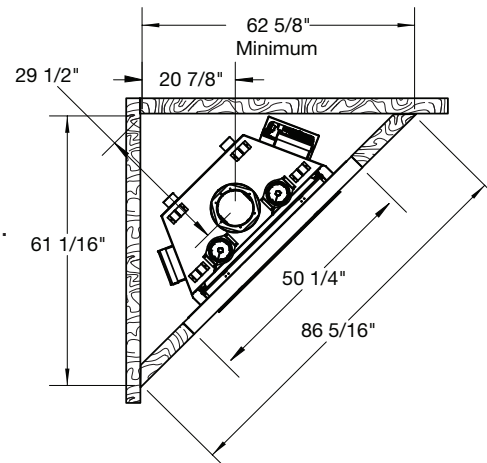

NOTE: Fireplace should be in its final location before framing.

Proflame 2 Control System

Town and Country D Series fireplaces use the SIT Proflame 2 control system.

This includes an elegant hand-held, programmable, multi-function remote control transmitter with an easy to read LCD display.

The fireplace also comes with a Town & Country's proprietary wall-mounted control panel which allows for simple ON/OFF operation, or can be linked with the hand-held remote control unit. This panel also accepts four double A batteries to provide for a back-up system during power outages. The wall-mounted panel also works on most customer supplied Home Automation Systems which allow for full control of fireplace flame and light modulation.

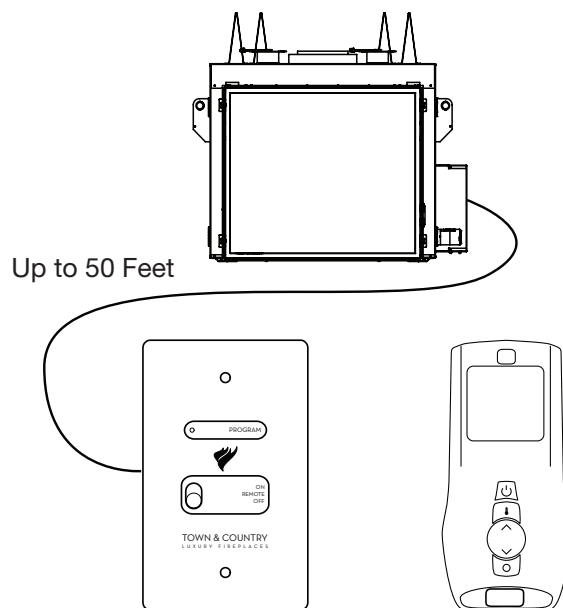

Hearth Extension

Caution: While a hearth extension is not required and combustible flooring materials may be brought directly up to the fireplace, many materials (such as wood flooring) may not tolerate the radiant heat from this fireplace, resulting in discoloration, shrinking and cracking. For this reason, we suggest a non-combustible hearth that is no more than 1" above the bottom of the fireplace. If material is thicker, fireplace must be raised accordingly.

Caution: Hearth extensions thicker than 1" will interfere with the window frame when opening.

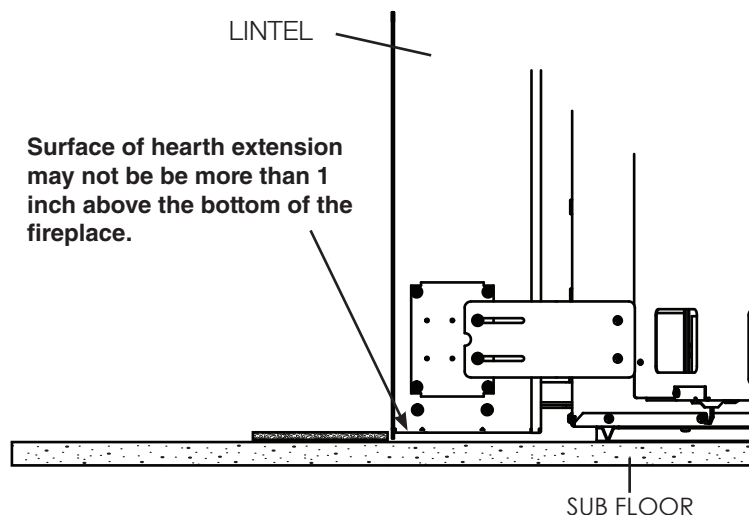

Side Facing Clearances

Caution: This fireplace may be recessed up to a maximum depth of 4 1/2". This recess must be constructed from non-combustible material. The space between the outside framing edge and the firebox must be completely free of any obstructions or debris, and the window, with trim fitted, must be able to move freely.

No building material is permitted to protrude past the framing edges attached to the fireplace under ANY circumstance.

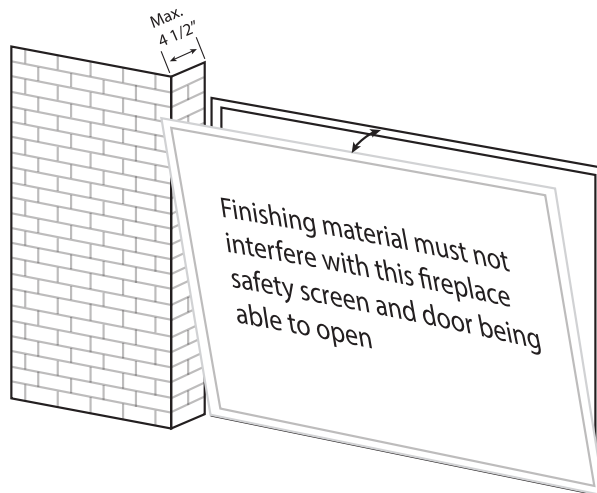

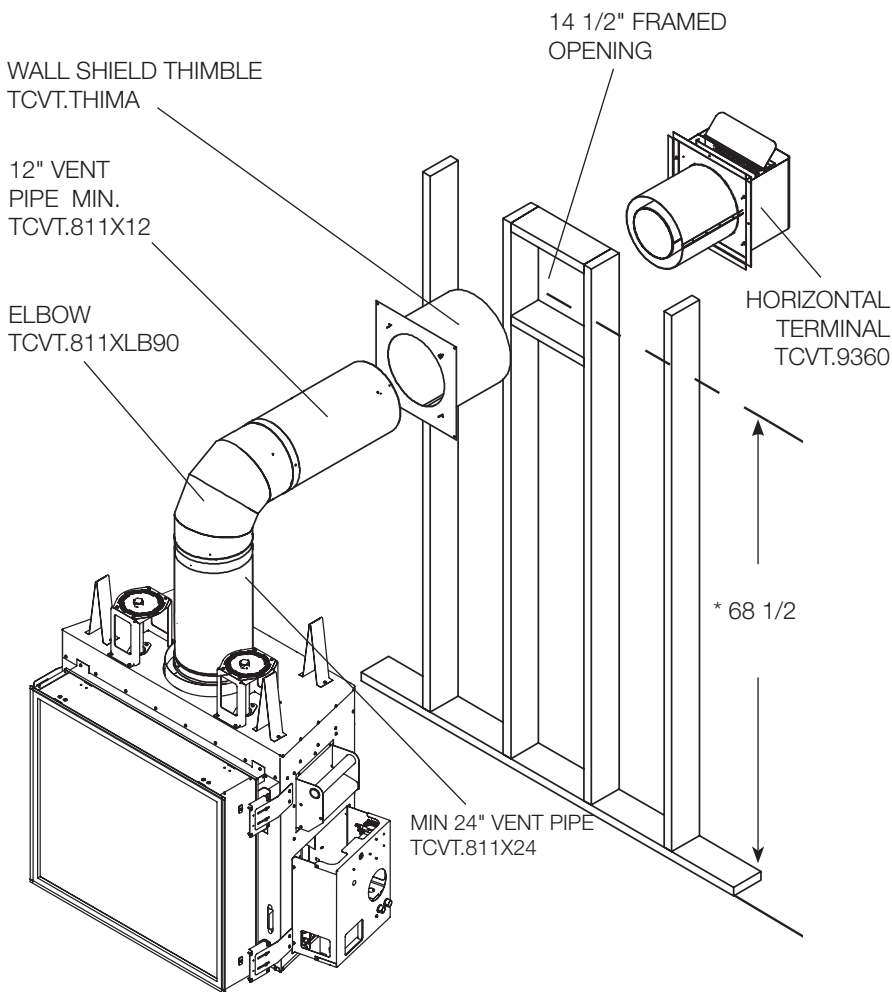

* Minimum height from the floor to center of the opening with a maximum horizontal run of 20 1/2" from the center of the flue outlet to the outside face of the outer wall. The height will need to be increased if a longer horizontal pipe is required.

Direct Vent Roof Installation

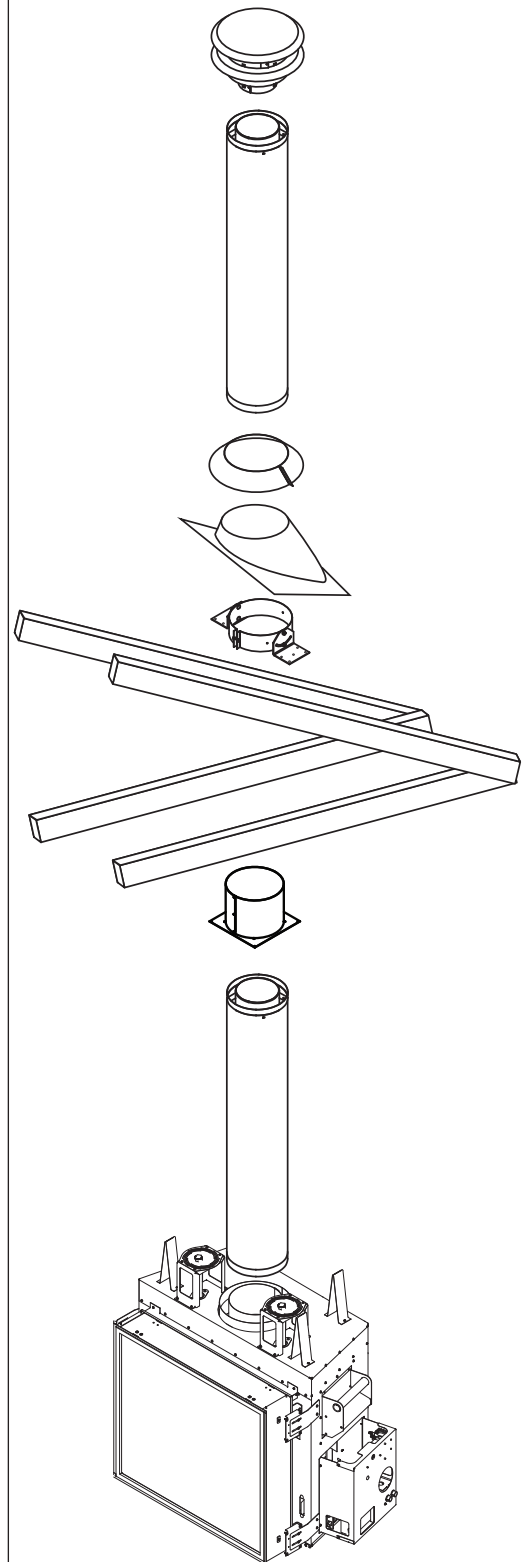

Wall Termination Venting Chart

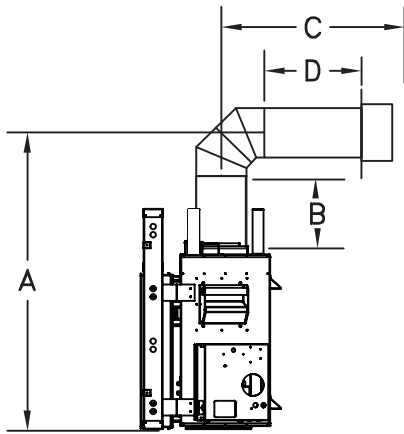

A Minimum rise	B Pipe length	C Maximum run	D Pipe length Max.
68 1/2"	1-24"	20 1/2"	1-12"
72 3/4"	1-12" 1-18"	75 3/4"	1-48" 1-12"
78 3/4"	1-24" 1-12"	11' 2"	2-48" 1-24"
84 3/4"	1-24" 1-18"	15' 10 1/2"	3-48" 1-24" 1-12"
92 1/2"	1-48"	20' 10 1/2"	5-48"

For other rise/run combinations see chart below

**** All dimensions are approximate. Both rise and run may vary with different combinations of pipe.**

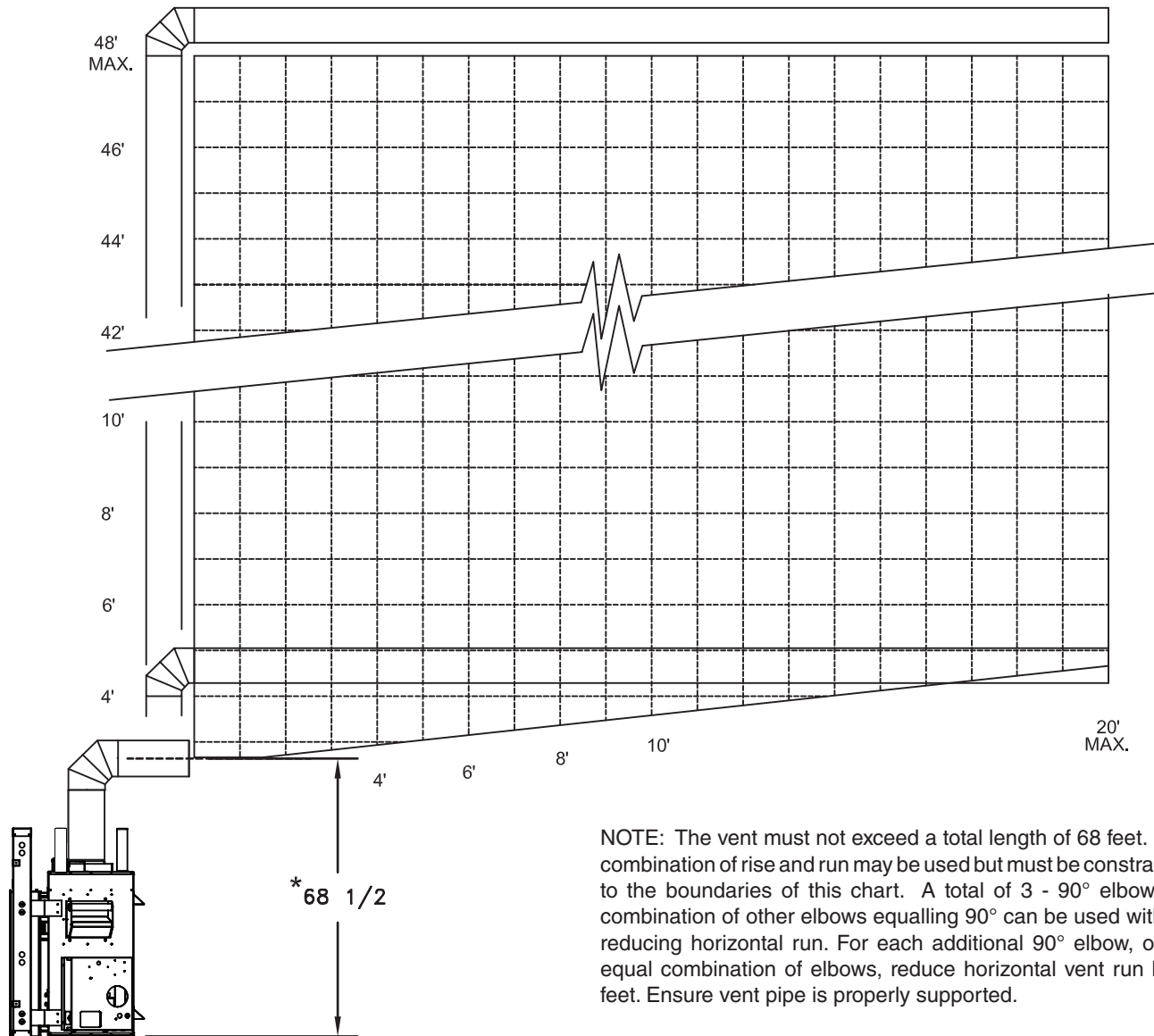

NOTE: The vent must not exceed a total length of 68 feet. Any combination of rise and run may be used but must be constrained to the boundaries of this chart. A total of 3 - 90° elbows or combination of other elbows equalling 90° can be used without reducing horizontal run. For each additional 90° elbow, or an equal combination of elbows, reduce horizontal vent run by 2 feet. Ensure vent pipe is properly supported.



TC36D2 Cad Drawing
Available at
www.townandcountryfireplaces.com

FOR REFERENCE ONLY. CONSULT MANUAL BEFORE INSTALLATION

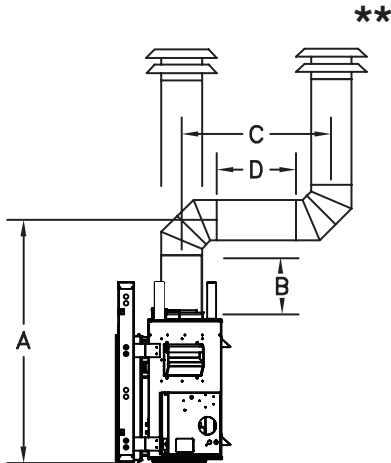

A Minimum rise	B Pipe length	C Maximum run	D Pipe length Maximum
68 1/2"	1-24"	29"	1-12"
72 3/4"	1-12" 1-18"	75 1/4"	1-48" 1-12"
78 3/4"	1-24" 1-12"	11' 1 1/2"	2-48" 1-24"
84 3/4"	1-24" 1-18"	15' 10"	3-48" 1-24" 1-12"
92 1/2"	1-48"	20' 10"	5-48"

For other rise/run combinations see chart below

**** All dimensions are approximate. Both rise and run may vary with different combinations of pipe.**

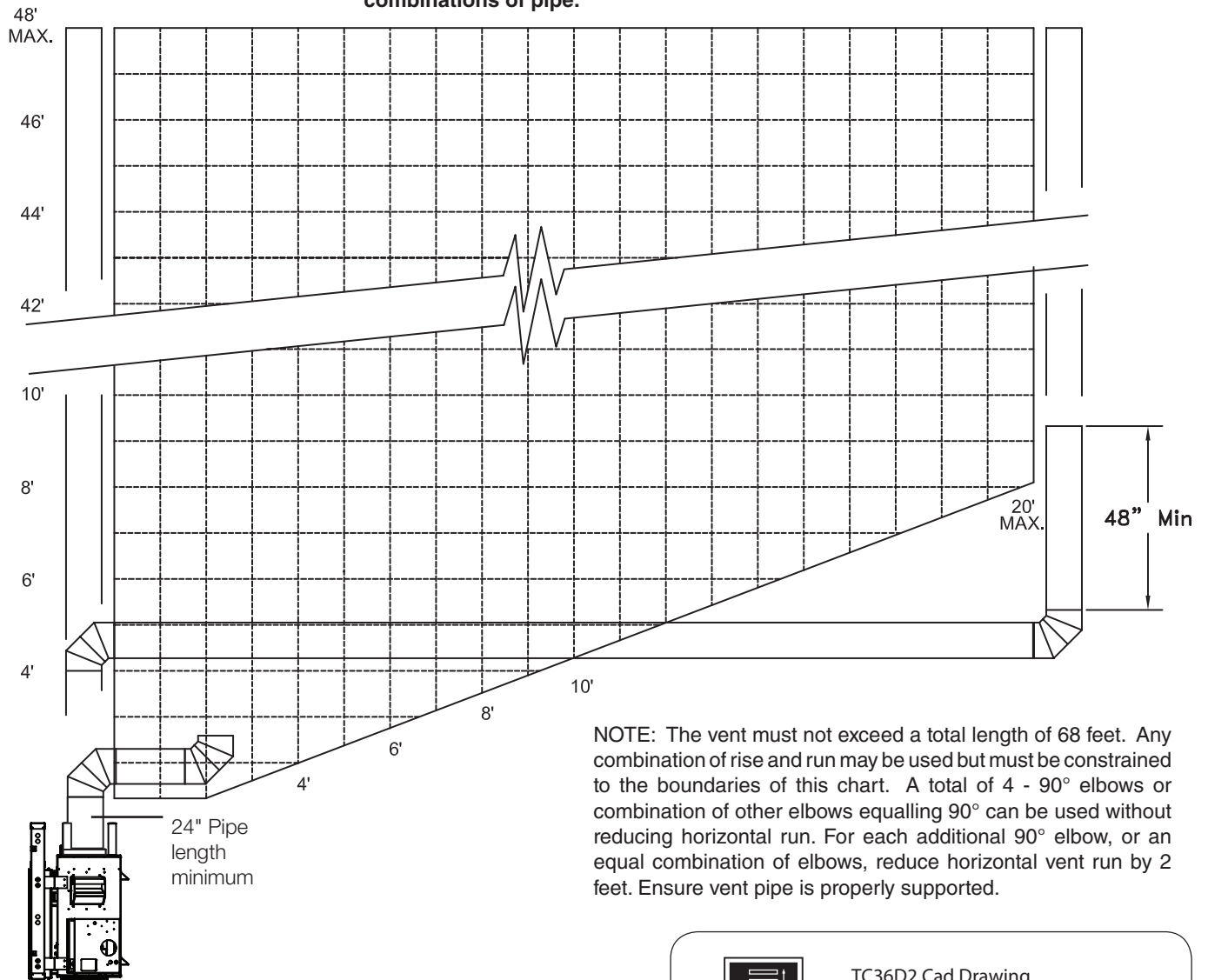

NOTE: The vent must not exceed a total length of 68 feet. Any combination of rise and run may be used but must be constrained to the boundaries of this chart. A total of 4 - 90° elbows or combination of other elbows equalling 90° can be used without reducing horizontal run. For each additional 90° elbow, or an equal combination of elbows, reduce horizontal vent run by 2 feet. Ensure vent pipe is properly supported.



TC36D2 Cad Drawing
Available at
www.townandcountryfireplaces.com

FOR REFERENCE ONLY. CONSULT MANUAL BEFORE INSTALLATION

Direct Vent Terminal Clearance

Minimum clearances to the vent terminal must be maintained as shown (See illustration to right & below). Measure clearances to the nearest edge of termination hood. (See pitch table below).

NOTE: Vent terminal must not be recessed

NOTE: LOCAL CODES OR REGULATIONS MAY REQUIRE DIFFERENT CLEARANCES.

Terminal to sloped Roof Pitch Table (minimum)

	ft	m
Flat to 6/12	1.00	0.30
Over 6/12 to 7/12	1.25	0.38
Over 7/12 to 8/12	1.50	0.46
Over 8/12 to 9/12	2.00	0.61
Over 9/12 to 10/12	2.50	0.76
Over 10/12 to 11/12	3.25	0.99
Over 11/12 to 12/12	4.00	1.22

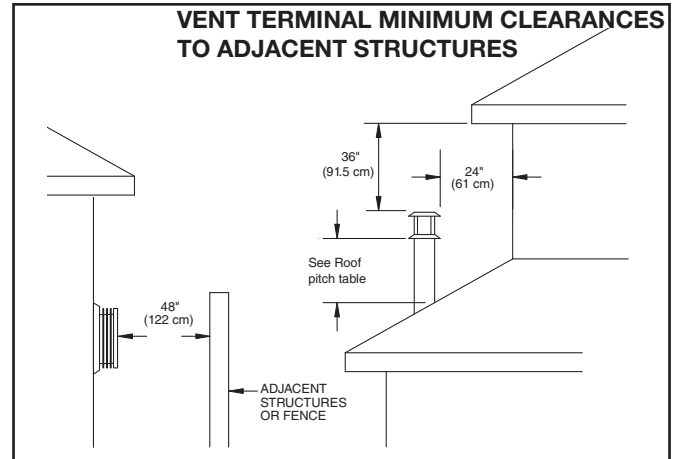

Direct Vent Terminal Minimum Clearances

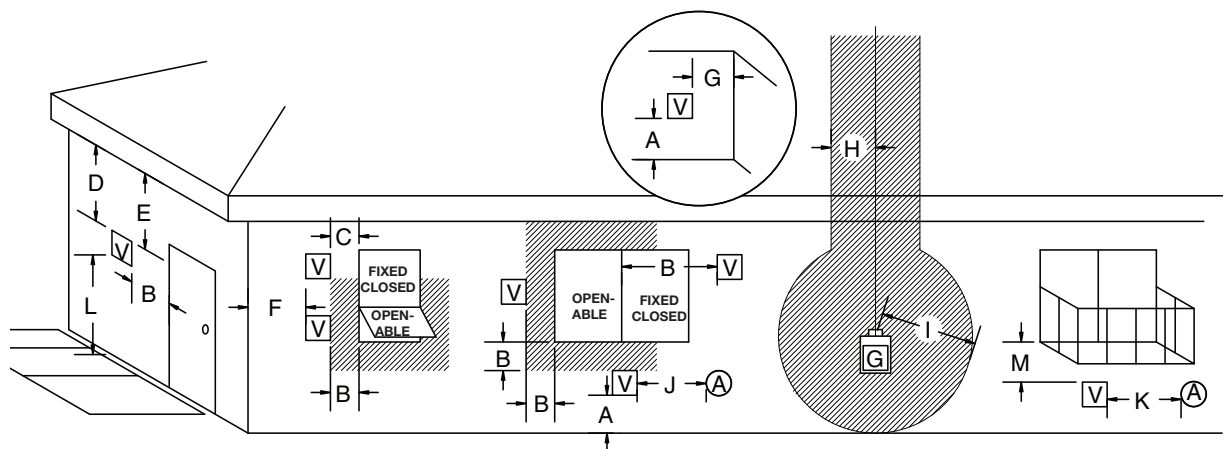

V VENT TERMINAL
 A AIR SUPPLY INLET
 AREA WHERE TERMINAL IS NOT PERMITTED
 G GAS METER

A=	*12 inches (30 cm) min.	Clearances above grade, veranda, porch, deck, or balcony
B=	*12 inches (30 cm) min.	Clearance to window or door that may be opened
C=	12 inches (30 cm) min.	Clearance to permanently closed window recommended to prevent condensation on window
D=	30 inches (76 cm) min.	Vertical clearance to ventilated soffit located above the terminal within a horizontal distance of 2 feet (60 cm) from the edge of the terminal
E=	30 inches (76 cm) min.	Clearance to unventilated soffit
F=	6 inches (15 cm) min.	Clearance to outside corner
G=	6 inches (15 cm) min.	Clearance to inside corner
H=	3 feet (90 cm) min.	*Not to be installed above a meter/regulator assembly within 3 feet (90 cm) horizontally from the center-line of the regulator
I=	*6 feet (1.8 m) min.	Clearance to service regulator vent outlet
J=	*12 inches (30 cm) min.	Clearance to non mechanical air supply inlet to building or the combustion air inlet to any other appliance
K=	*6 feet (1.8 m) min.	Clearance to a mechanical air supply inlet
L=	*7 feet (2.1 m) min.	^ Clearance above paved side-walk or a paved driveway located on public property
M=	**30 inches (76 cm) min	Clearance under veranda, porch, deck, or balcony

^ a vent shall not terminate directly above a side-walk or paved driveway which is located between two single family dwellings and serves both dwellings*

** only permitted if veranda, porch, deck, or balcony is fully open on a minimum of 2 sides beneath the floor*

* as specified in CAN/CSA B149.1 Installation Codes, Note: local Codes or Regulation may require different clearances

* for U.S.A. Installations follow the current National Fuel Gas Code, NFPA54/ANSI Z223.1

FOR REFERENCE ONLY. CONSULT MANUAL BEFORE INSTALLATION

Reach almost any room or commercial setting. Optional Power Venting allows runs up to 110' from an outside wall or roof surface. Vent horizontally or vertically with up to six 90-degree elbows, including runs up to 3' below the fireplace.

The premium Power Vent fan runs quietly outside, at the exterior terminal.

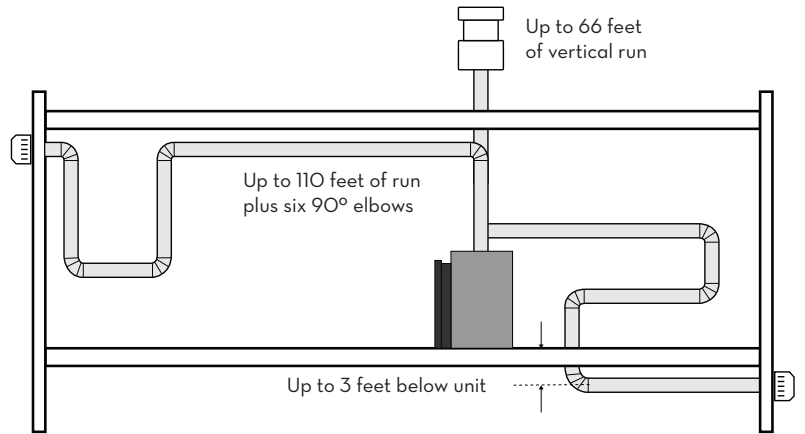



TC36D2 Cad Drawing
Available at
www.townandcountryfireplaces.com

Power Vent Terminals



Roof Termination

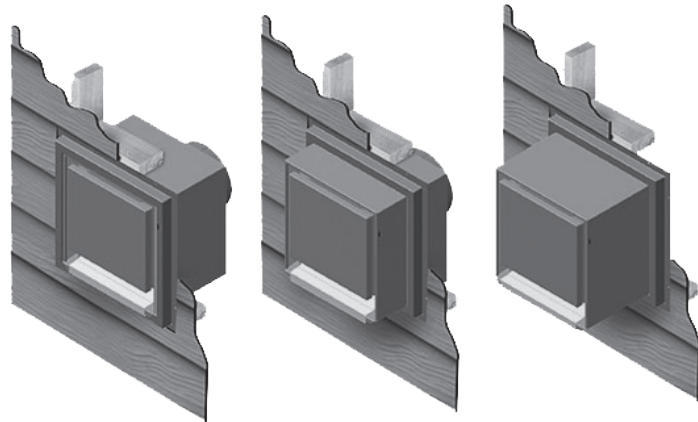

Flush Mount termination

Direct Vent Terminals



**Standard Venting
Roof Termination**



**Standard Venting
Wall Termination**



**Stainless Steel Standard Venting
Termination for Condo Installation**

© 2018 Copyright Pacific Energy Fireplace Products LTD

Reproduction, adaptation, or translation
without prior written permission is prohibited,
except as allowed under the copyright laws.



TOWN & COUNTRY
L U X U R Y F I R E P L A C E S

For personal service pertaining to specific projects, contact:
Town & Country Architect Resource Planner
architects@townandcountryfireplaces.com
www.townandcountryfireplaces.com
Phone: (250) 748-1184
2975 Allenby Road, Duncan, BC Canada V9L 6V8