



CONCRETE FIRE PIT - 42Dreambowl

Our firebowls are a beautiful feature for any outdoor space. They are a perfect center piece to entertainment areas or relaxing retreats.

Every firebowl is complete with a CSA approved gas fit burner and decorative lava rock, for a natural yet modern look. Side or bottom gas line access holes available.

Each firebowl is complete with a 6" sculpted rim for greater functionality.

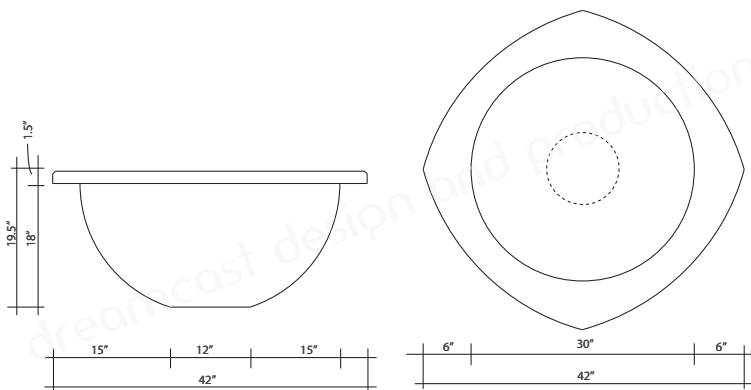

Key Features:

- Natural gas or propane
- Manual lit or electronic ignition
- 60,000 btu
- Ships Canada and USA

Integral Concrete Colors:



visit us at: www.dreamcastdesign.com



DreamCast
design and production

2200 Vauxhall Place
Richmond, BC Canada
604-278-4939
info@dreamcastdesign.com