

- Installation Instructions -



Model Numbers: HBZDV3624N, HBZDV3624NE, HBZDV3624NE2,
HBZDV3624LP, HBZDV3624LPE, HBZDV3624LPE2
HBZDV3628N, HBZDV3628NE, HBZDV3628NE2,
HBZDV3628LP, HBZDV3628LPE, HBZDV3628LPE2
MQHBZDV3636N, MQHBZDV3636NE, MQHBZDV3636NE2,
MQHBZDV3636LP, MQHBZDV3636LPE, MQHBZDV3636LPE2

Certified to: CSA/ANSI Z21.88:19 • CSA 2.33:19 and CSA 2.17-2017
VENTED GAS FIREPLACE HEATERS

**⚠ WARNING:
FIRE OR EXPLOSION HAZARD**

Failure to follow safety warnings exactly could result in serious injury, death, or property damage.

-Do not store or use gasoline or other flammable vapors and liquids in the vicinity of this or any other appliance.

-WHAT TO DO IF YOU SMELL GAS

- Do not try to light any appliance.
- Do not touch any electrical switch; do not use any phone in your building.
- Leave the building immediately.
- Immediately call your gas supplier from a neighbor's phone. Follow the gas supplier's instructions.
- If you cannot reach your gas supplier, call the fire department

-Installation and service must be performed by a qualified installer, service agency or the gas supplier.

INSTALLER: Leave this manual with the appliance. **CONSUMER:** Retain this manual for future reference.

This appliance may be installed in an aftermarket, permanently located, manufactured home (USA only) or mobile home, where not prohibited by local codes.

This appliance is only for use with the type of gas indicated on the rating plate. This appliance is not convertible for use with other gases, unless a certified kit is used.



For Propane Horizontal installations the venting must be a minimum of one foot vertical off the flue before going horizontal.



**VENTED GAS FIREPLACE HEATER:
NOT FOR USE WITH SOLID FUEL**

SOLACE

SOLACE II

IT IS THE RESPONSIBILITY OF THE HOME OWNER TO ENSURE THAT NO ONE TOUCHES A HOT APPLIANCE.

- If the barrier becomes damaged, the barrier shall be replaced with the manufacturer's barrier for this appliance.
- Any safety screen, guard, or barrier removed for servicing the appliance, must be replaced prior to operating the appliance.
- Children and adults should be alerted to the hazards of the high surface temperatures of this appliance and should stay away to avoid burns or ignition of clothing.
- Do not clean when the glass is hot.
- Young children should be carefully supervised when they are in the same room as the appliance. Toddlers, young children and others may be susceptible to accidental contact burns.
- A physical barrier is recommended if there are at risk individuals in the house. To restrict access to a fireplace or stove, install an adjustable safety gate to keep toddlers, young children and other at risk individuals out of the room and away from hot surfaces.
- Do not leave the fireplace remote control where it is accessible to children.



DANGER



**HOT GLASS WILL CAUSE BURNS.
DO NOT TOUCH GLASS UNTIL COOLED.
NEVER ALLOW CHILDREN TO TOUCH GLASS.**

A barrier designed to reduce the risk of burns from the hot viewing glass is provided with this appliance and must be installed for the protection of children and other at-risk individuals.

If the barrier becomes damaged, the barrier must be replaced with the manufacturer's barrier for this appliance.



WARNING:

A HORIZONTAL VENT CERTIFIED GUARD (SAFETY CAGE) IS AVAILABLE WHEN REQUIRED BY LOCAL CODES.

SAFETY CAGES ARE AVAILABLE FOR ALL HORIZONTAL VENT TERMINATIONS. CHECK WITH YOUR DEALER.

- **TERMINATION CAP IS HOT!** Do not place flammable materials on or within 24 inches of termination caps.
- It is imperative that the vent termination be located observing the minimum clearances as shown in manual.
- There must not be any obstruction such as bushes, garden sheds, fences, decks or utility buildings within 24" from the front of the termination plate.
- Do not locate termination where excessive snow or ice build-up may occur. Be sure to check vent termination area after snow falls and clear to prevent accidental blockage of venting system. When using snow blowers, make sure snow is not directed towards vent termination area.
- Venting terminal shall not be recessed into a wall or siding.

Table of Contents

Glass Safety / Termination Cap Safety.....	2
Table of Contents.....	3-4
Pre-installation Questions and Answers / Operations and Maintenance Instructions.....	5
Safety Screen Installation.....	6
Warnings, Installations and Operations - Installation Regulations.....	7
Installation Requirements for the Commonwealth of Massachusetts / Carbon Monoxide (CO) Detector.....	8
Mobile Home/Manufactured Housing Installation.....	9
Installation & Framing	
Fireplace Installations in Covered Outdoor Locations.....	10
Locating your Appliance / Unit Dimensions.....	11
Framing for your Gas Fireplace.....	12
HBZDV36 - Framing and Facing Requirements.....	13
Clearance to Combustibles.....	14
How to Install Clean View Kit (CVCK).....	14
HB36SBL & HB42SBL Surrounds.....	15
Clearances – HB36 / HB42 / HB47 – Mantels.....	16
Mantel Leg Clearances.....	17
Accessories and Options	
Fan Kit Installation.....	18
Split Receptacle- Fan Speed Control Outside of Fireplace.....	19
Brick Installation.....	20
Installation of HB Porcelain Liners - HB36PL.....	21
Door and Glass Information.....	22
Appliance/Log Reference Chart/Log Placement.....	22
LOGF36 for MQHBZDV3636.....	23
MQLOGF36BW 6 Piece Birch Log Set.....	24
LOGC42 - LOG C43 LOG Placement.....	25-26
LOGC44 Placement.....	27-29
MQLOGC45 Oak Logset Placement.....	30-31
MQRSP3 with Pilot Shield.....	32
Installing MQRSP3.....	33
Pilot Shield RSP1 / RSP2.....	34
MQROCK1/MQRSP2.....	35-36
MQROCK1/MQRSP3.....	37-38
Burner System	
Gas Line Installation.....	39
Annual Inspection List for Determining Safe Operation of a Direct Vent Gas Fireplace.....	40
Troubleshooting the Gas Control System.....	41
Burner System Maintenance.....	42
Conversion Kit Instructions Part A.....	42-43
Conversion Kit Instructions Part B - SIT Pilot.....	44
Conversion Kit Instructions Part C - SIT Modulator.....	45
Removing Burner System.....	46
Millivolt System, Lighting, and Burner Control.....	47
Lighting Instructions for Millivolt Valve with 7 Day Timer.....	48
Electronic Ignition Lighting Instructions.....	49
Proflame 1	
Overview / Components.....	50
Remote Control Operation.....	51
Proflame 1 Parts List.....	52
Configuration #1: Basic Manual HI/LO and Manual ON/OFF Capabilities.....	53
Configuration #2: Remote ON/OFF and Manual HI/LO Capabilities.....	54

Operating the Receiver Without Batteries- Millivolt and Proflame 1.....	55
Configuration #3: Remote ON/OFF, variable HI/LO, and Fan Capabilities.....	56
Proflame 2	
Proflame 2 Parts List / Schematic.....	57
Proflame 2 Module and Remote Control.....	58
Cold Climates – CPI Setting - Proflame 2 Remote Control.....	59
Proflame 2 Remote Control.....	60-61
Proflame 2 Label Diagram.....	62
Venting	
Vent Terminal Clearances.....	63
General Vent Installation	64
Installation of Side Wall Venting.....	65
Venting Routes and Components / Horizontal Venting Table from Bottom of Fireplace.....	66
Z47ST24 / Z47ST36 Horizontal Snorkel Terminations.....	67
Venting Straight Up Through Roof.....	68-69
Fireplace Installations Using Co Linear Flex Kits.....	70
Approved for Power Vent PVH58.....	71
Parts Lists	
PVH58 Parts List.....	72
Parts Lists.....	73-76
Warranty	
Limited Lifetime Warranty.....	77

Pre-installation Questions and Answers

About curing of the paint

Your stove or fireplace has been painted with the highest quality silicone stove paint. This paint dries quickly in 15-20 minutes when first applied at the factory. However, due to the high temperature silicone components, the paint will cure when heat is applied to the appliance as it is first used. The following information applies to the curing process to get the paint fully hard and durable. **Note: Use of painter's tape is not recommended, as it may damage the paint.**

Fire the appliance four successive times for 10 minutes each firing and a 5 minute cool down between each. Be aware during log and firebox paint curing that a white deposit may be developing on the inside of the glass doors. It is important to remove this white deposit from the glass doors using a fireplace glass cleaner.

- Babies, small children, pregnant women and pets should leave the area during the cure phase.
- Ventilate well, open doors and windows.
- Do not touch during curing.

Why does my fireplace or stove give off odor?

It is normal for your fireplace to give off some odor at first. This is due to the curing of the paint, adhesives, silicones and any undetected oil from the manufacturing process as well as the finishing materials used with the installations (e.g. marble, tile and the adhesives used to adhere this product to the walls can react with heat and cause odors).

It is recommended that you burn your gas fireplace or stove for a minimum of four hours at a time with the fan off (if a fan is present) after the curing of the paint has been completed. These odors can last upward to 40 hours of burn time; keep burning at a minimum of four hours per use until odors dissipate.

Noise coming from the fireplace?

Noise is caused by the expansion and contraction of metal as the appliance heats up and cools down. This is normal and is similar to the sounds produced by a furnace or heating duct. This noise does not affect the operation or longevity of your fireplace.

It is also normal for the fan to make some noise when it comes on. This noise can be reduced somewhat by turning down the speed of the fan with the variable speed control. Be aware, however, that this will reduce the volume of heated air circulated into the room by the fan.

Note to the Installer:

Be sure appliance is working properly and its operation (including remote control operation, if included) is fully explained to and understood by the customer.

Operations and Maintenance Instructions

For safe installation and operation note the following:

- Be sure to read and understand all the instructions in this manual before operation of appliance.
- Ensure all wiring is correct and properly enclosed to prevent possible shock.
- Check for gas leaks.
- Make sure the glass door is properly installed before operation. Never operate the appliance with the glass door removed.
- Make sure venting and termination cap are installed and unobstructed.
- If brick or porcelain liners are used, ensure they are installed.
- Verify that the pilot can be seen when lighting the appliance. If not, the log or rock placement is incorrect.
- If the unit is turned off, you must wait a minimum of 60 seconds before re-lighting it.
- Venting systems should be periodically examined by a qualified agency.
- The flow of combustion and ventilation air must not be obstructed.
- The Burner/Log Assembly has been engineered and permanently adjusted for proper flame control.
- Periodically remove the logs from the grate assembly and vacuum any loose particles from the grate and burner areas. See Log Placement page to remove logs. Vacuum burner parts and replace logs.
- Never use your gas fireplace as a cooking device.
- Label all wires prior to disconnection when servicing controls. Wiring errors can cause improper and dangerous operation. Verify proper operation after servicing.
- Areas in and around the Chase Vent Openings should be cleaned annually.

Safety Screen Installation Z Series

Contents of Kit:

- [1] Safety Screen
- [2] Side Angles
- [2] Horizontal Angles
- [12-16] DT Screws (Depending on screen size)

Assembly: Attach components with supplied screws as shown.

NOTE: Screens are symmetrical from top to bottom.

⚠ WARNING:

Wait until unit is **COMPLETELY** cool before touching glass or attempting to install or remove Child Safety Screens.

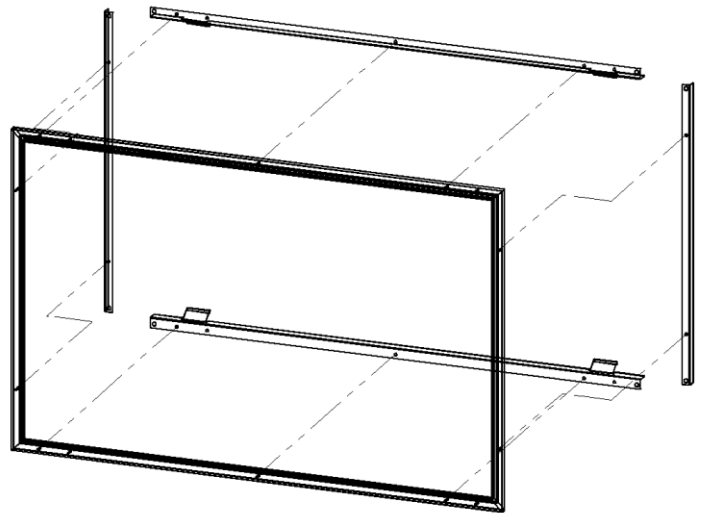

Screen with Side & Horizontal Angles

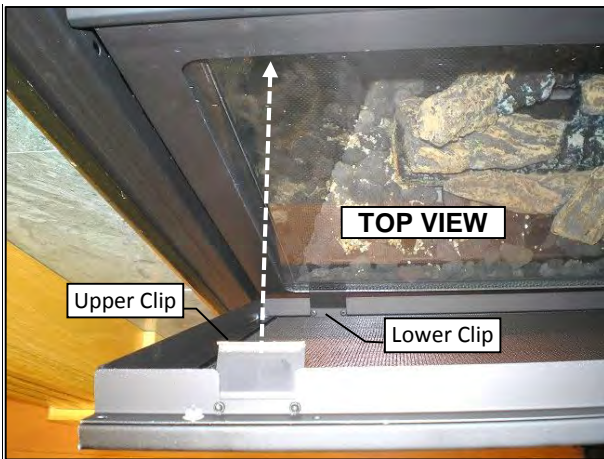

Hook Lower Clip onto glass door frame.

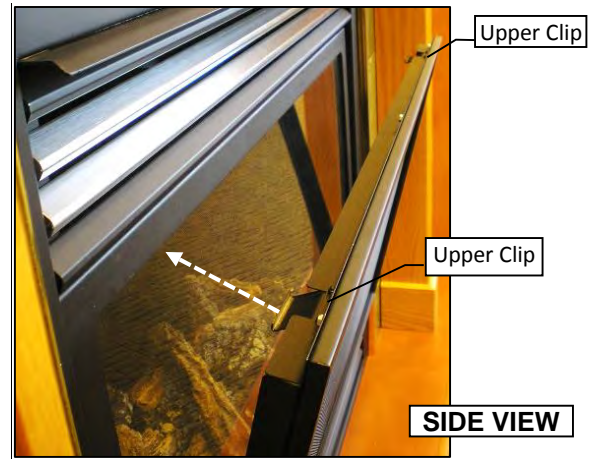

Press down and push upper clip under top glass door frame.

To install screens

hook bottom clip onto glass door frame, then press down and push upper clip under top glass door frame, then release. Clip will hook onto frame.

Fireplace with Screen



To remove Safety Screens
WAIT UNTIL FIREPLACE IS COMPLETELY COOL.

Press down on upper clips and remove screen from fireplace glass door.

Warnings, Installations and Operations - Installation Regulations

This gas appliance must be installed by a qualified installer in accordance with local building codes, or in the absence of local codes, with the current CAN/CSA-B149.1 or .2 Installation Code (in Canada) or the current National Fuel Gas Code Z223.1- NFPA 54 when installed in the United States. This appliance, when installed, must be electrically connected and grounded in accordance with local codes, or in the absence of local codes, with the current CSA C22.1 Canadian Electrical Code or with the National Electrical Code; ANSI/NFPA 70 when installed in the United States.



FOR SAFE INSTALLATION AND OPERATION OF YOUR GAS FIREPLACE PLEASE NOTE THE FOLLOWING:

1. Do not clean when the glass is hot.
2. Do not use abrasive cleaners.
3. Using a substitute glass will void all product warranties.
4. For safe operation, glass doors must be closed.
5. When purging the gas line, the glass front must be removed.
6. Do not strike or abuse glass. Take care to avoid breakage.
7. Do not alter gas orifice.
8. No substitute materials may be used other than factory supplied components.
9. This appliance gives off high temperatures and should be located out of heavy traffic areas and away from furniture and draperies.
10. Children and adults should be alerted to the hazards of the high surface temperatures of this appliance and should stay away to avoid burns or ignition of clothing.
11. Young children should be carefully supervised when they are in the same room as the appliance. Toddlers, young children and others may be susceptible to accidental contact burns. A physical barrier is recommended if there are at risk individuals in the house. To restrict access to a fireplace or stove, install an adjustable safety gate to keep toddlers, young children and other at risk individuals out of the room and away from hot surfaces.
12. Under no circumstances should any solid fuels (wood, paper) be used in this appliance.
13. Under no circumstances should this appliance be modified. Any parts that have to be removed for servicing should be replaced prior to operating this appliance.
14. Any safety screen, guard, or barrier removed for servicing an appliance must be replaced prior to operating the appliance.
15. Installation and repair should be done by a qualified service person. The appliance should be inspected before use and at least annually by a professional service person. More frequent cleaning may be required due to excessive lint from carpeting, bedding material, et cetera. It is imperative that control compartments, burners and circulating air passageways of the appliance be kept clean. Make sure that the gas valve and pilot light are turned off before you attempt to clean this unit.
16. Clothing or other flammable material should not be placed on or near the appliance. This appliance should not be used as a drying rack for clothing nor should Christmas stockings or decorations be hung from it.
17. Do not use this heater if any part has been under water. Immediately call a qualified service technician to inspect the heater and to replace any part of the control system and any gas control which has been under water.
18. Do not operate appliance unless completely installed as per installation instructions.
19. Failure to position the parts in accordance with these diagrams or failure to use only parts specifically approved with this appliance may result in property damage or personal injury.
20. **WARNING: Do not operate appliance with the glass front removed, cracked or broken. Replacement of the glass should be done by a licensed or qualified service person.**
21. The appliance area must be kept clear and free from combustible materials, gasoline, and other flammable vapors and liquids.
22. The front of the fireplace gives off high temperatures that could ignite combustible material which is kept close to the front of the unit.
23. Ensure that power to the Fireplace is turned off before servicing.
24. Do not operate this Fireplace without the glass front or with a broken glass.
25. Improper installation, adjustment, alteration, service or maintenance can cause injury or property damage. Refer to the owner's information manual provided with this appliance. For assistance or additional information consult a qualified installer, service agency, or the gas supplier.
26. Operation of this appliance when not connected to a properly installed and maintained venting system or tampering with the blocked vent shutoff system can result in carbon monoxide (CO) poisoning and possible death.
27. This appliance is equipped with a three-prong (grounding) plug for your protection against shock hazard and should be plugged directly into a properly grounded three-prong receptacle. Do not cut or remove the grounding prong from this plug.
28. **NOT INTENDED FOR USE AS A PRIMARY HEAT SOURCE.** This appliance is tested and approved as either supplemental room heat or as a decorative appliance. It should not be factored as primary heat in residential heating calculations.
29. This appliance must not be connected to a chimney flue serving a separate solid-fuel burning appliance.
30. Remove all loose materials from the appliance (manual, remote control, etc.) before connecting gas and electricity.
31. Ensure that the remote control is "OFF" before connecting gas and electricity to the appliance.

Installation Requirements for the Commonwealth of Massachusetts

In the Commonwealth of Massachusetts, the installer or service agent shall be a plumber or gas fitter licensed by the Commonwealth.

When installed in the Commonwealth of Massachusetts or where applicable codes; the unit shall be installed with a CO detector per the requirements listed below.

1. For direct-vent appliances, mechanical-vent heating appliances or domestic hot water equipment, where the bottom of the vent terminal and the air intake is installed below four feet above grade the following requirements must be satisfied:
 - A. If there is not one already present, on each floor level where there are bedroom(s), a carbon monoxide detector and alarm shall be placed in the living area outside the bedroom(s). The carbon monoxide detector shall comply with NFPA 720.
 - B. A carbon monoxide detector shall be located in the room that houses the appliance or equipment and shall:
 - Be powered by the same electrical circuit as the appliance or equipment such that only one service switch services both the appliance and the carbon monoxide detector;
 - Have battery back-up power;
 - Meet ANSI./UL 2034 Standards and comply with NFPA 720; and
 - Have been approved and listed by a Nationally Recognized Testing Laboratory as recognized under 527 CMR.
 - C. A Product-approved vent terminal must be used, and if applicable, a Product-approved air intake must be used. Installation shall be in strict compliance with the manufacturer's instructions. A copy of the installation instructions shall remain with the appliance or equipment at the completion of the installation.
 - D. A metal or plastic identification plate shall be mounted at the exterior of the building, four feet directly above the location of vent terminal. The plate shall be of sufficient size to be easily read from a distance of eight feet away, and read "Gas Vent Directly Below".
2. For direct-vent appliances, mechanical-vent heating appliances or domestic hot water equipment where the bottom of the vent terminal and the air intake is installed above four feet above grade the following requirements must be satisfied:
 - A. If there is not one already present, on each floor level where there are bedroom(s), a carbon monoxide detector and alarm shall be placed in the living area outside the bedroom(s). The carbon monoxide detector shall comply with NFPA 720.
 - B. A carbon monoxide detector shall:
 - Be located in the room that houses the appliance or equipment;
 - Be either hard-wired or battery powered or both; and
 - Shall comply with NFPA 720.

A Product-approved vent terminal must be used, and if applicable, a Product-approved air intake must be used. Installation shall be in strict compliance with the manufacturer instructions. A copy of the installation instructions shall remain with the appliance or equipment at the completion of the installation.

For the state of Massachusetts a **T-handle gas shut-off valve** must be used on a gas appliance. This T-handle gas shut-off valve must be listed and approved by the state of Massachusetts. This is in reference to the state of Massachusetts state code CMR238.

Carbon Monoxide (CO) Detector

NOTE: It is recommended that a Carbon Monoxide (CO) Detector be installed in or near bedrooms and on all levels of your home. Place a detector about 15ft [4.5m] outside the room that houses your gas appliance.

Certified for installation in a bedroom or bed/sitting room. In Canada must be installed with listed millivolt thermostat. In USA see local codes.



WARNING

This product and the fuels used to operate this product (liquid propane or natural gas), and the products of combustion of such fuels, can expose you to chemicals including benzene, which is known to the State of California to cause cancer and reproductive harm. For more information go to: www.P65Warnings.ca.gov.

Mobile Home/Manufactured Housing Installation

This Direct Vent System Appliance must be installed in accordance with the manufacturer's installation instructions and the Manufactured Home Construction and Safety Standard Title 24 CFR, Part 3280, or the current Standard for Fire Safety Criteria for Manufactured Home Installations, Sites, and Communities ANSI/NFPA 501A, and with CAN/CSA Z240 MH Mobile Home Standard in Canada.

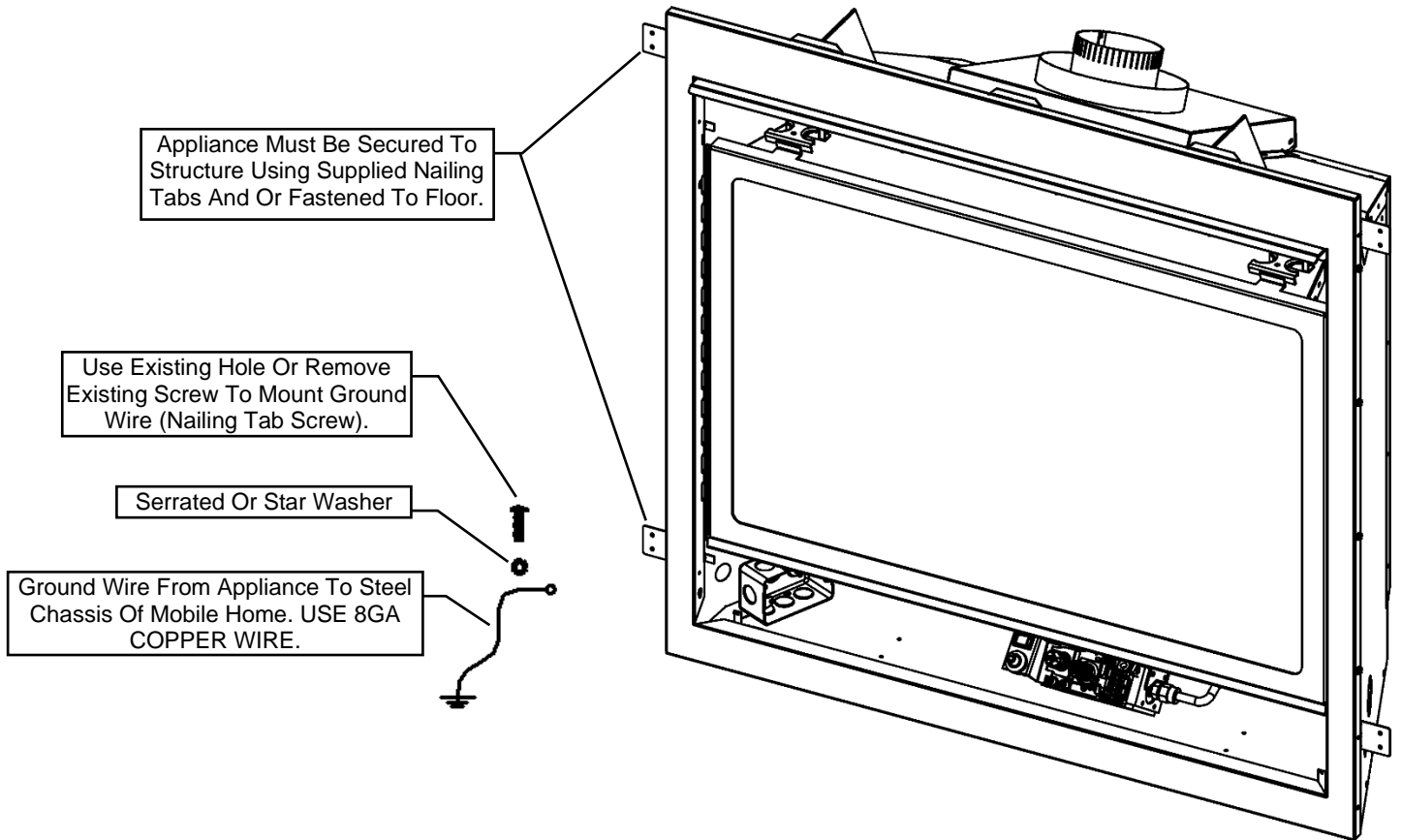

THE HBZDV3628N/NE/NE2 & HBZDV3628LP/LPE/LPE2 MAY BE INSTALLED IN MANUFACTURED (MOBILE) HOMES AFTER FIRST SALE IN THE USA. IN CANADA THE HBZDV3628N/NE/NE2 & HBZDV3628LP/LPE/LPE2 MAY BE INSTALLED IN MANUFACTURED (MOBILE) HOMES.

Please follow the current ANSI/NFPA 70 National Electrical Code in the USA and CAN/CSA C22.1 Canadian National Electrical Code in Canada.

An appliance must be grounded to the steel chassis of the home with 8 ga. copper wire using a serrated or star washer to penetrate paint or protective coating to insure grounding.
Use carriage bolt at the attachment point (see diagram above) to secure the appliance to the floor.



Warning: Do not compromise the structural integrity of the manufactured home wall, floor or ceiling, during installation of appliance or venting.

For required venting components see venting installation in appropriate section of this manual.

Certified for installation in a bedroom or bed/sitting room.

Fireplace Installations in Covered Outdoor Locations – FOR BASIC MILLIVOLT UNITS ONLY- NO FAN – NO LIGHTS-

CAUTION – Installation of an indoor gas fireplace with an outdoor exposure is not covered under the (ANSI Z21.88 – CSA 2.22 or ANSI Z21.50 – CSA 2.33) standard(s) used to certify the indoor gas-fired fireplace. The Intertek safety certification will not apply to this installation method. This installation method must be deemed acceptable by the Authority Having Jurisdiction (AHJ) prior to the indoor gas fireplace being installed.

Kingsman and Marquis Direct Vent fireplaces may be installed into outdoor locations provided they are suitably protected from direct water impingement. However, all installation clearances in the appliance manual must be observed. Framing, Clearances to Combustibles, Mantel Heights, Facing Requirements, Venting Installation, etc. **Use supplied Safety Screen.**

- All wiring connections to line power shall be in accordance with outdoor requirements of; -NECA NFPA 70 in the USA -Canadian Electrical Code, CSA C22.1 for Canada.
- The Fireplace is not to be operated in temperatures below freezing (0°C / 32°F).
- **⚠ NOTE: TEMPERED GLASS WARNING:** Tempered glass is vulnerable to rapid and/or extreme changes in temperature (thermal shock). Take care to prevent water from contacting the fireplace, especially if it is hot.
- See-Through Units are suitable for an outdoor location, but not on the outside wall of a house or other structure, as air flows through both sides of the fireplace.
- A Minimum sheltering cover (overhang) of 1/2 the distance from the base of the fireplace to the ceiling (base of roofline) is required.

EXAMPLE: The bottom of the fireplace is 84" from the ceiling. Therefore, 42" of sheltering cover is required above fireplace.

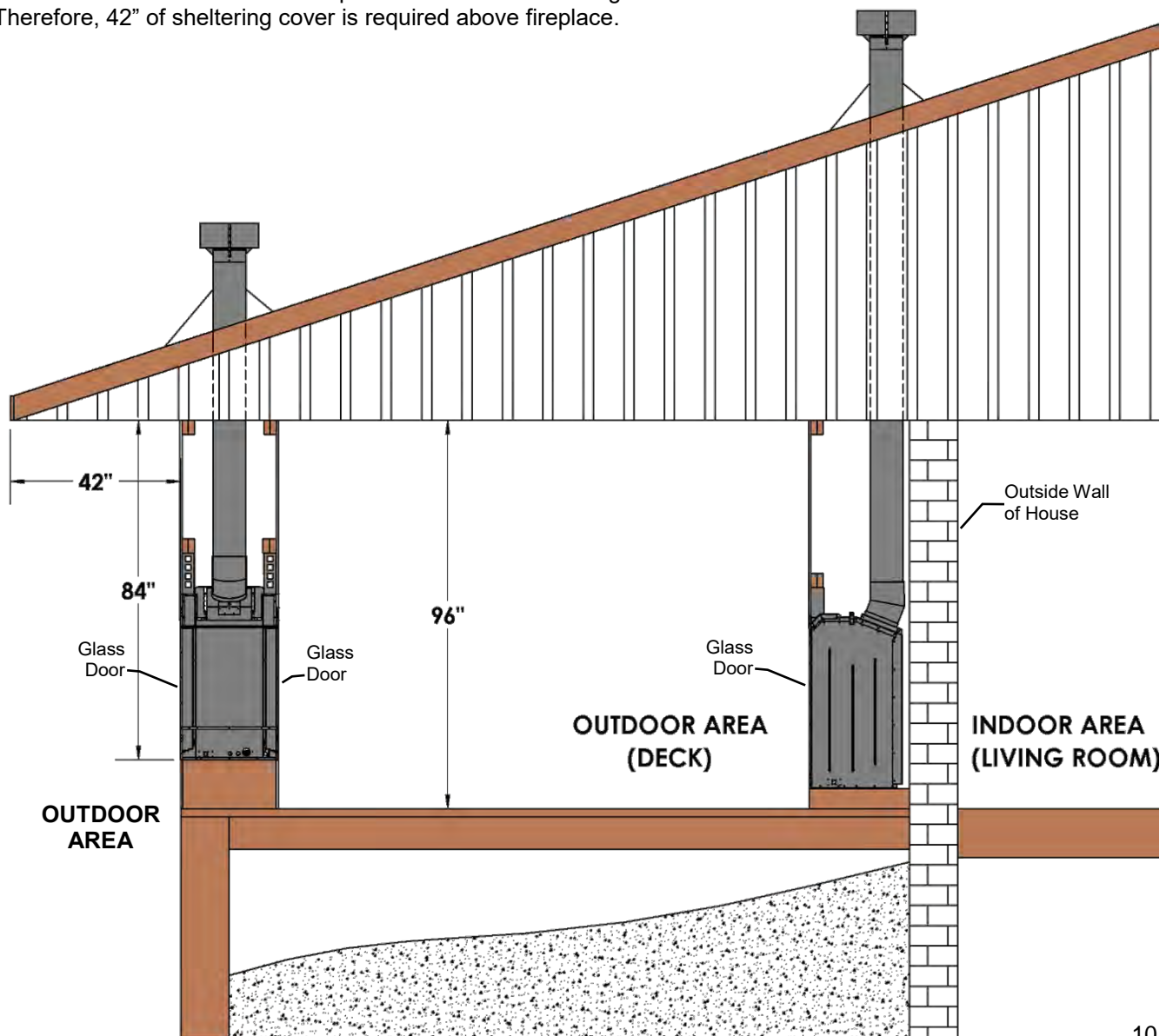

Locating Your Appliance

LOCATION KEY:

- A. Flat on Wall
- B. Across the Corner
- C. As an Island
- D. As a Room Divider
- E. Flat on Wall Corner
- F. Exterior Wall

See Mantel Leg Clearances Instruction for the proper placement of fireplace.

Island installation with a top vent is possible as long as the horizontal portion of the vent system does not exceed 20 feet (6.1 m).

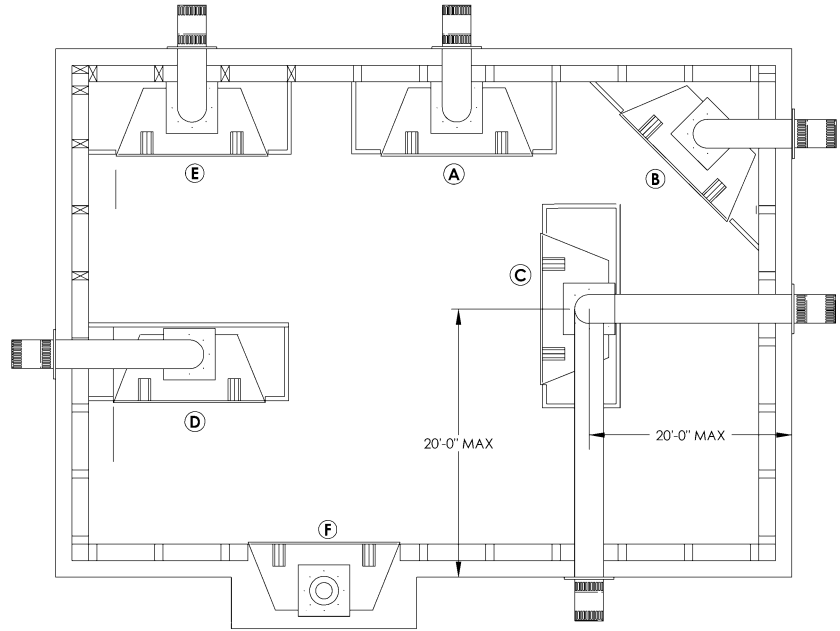

Fireplace Dimensions

HBZDV36

HBZDV36-CVCK

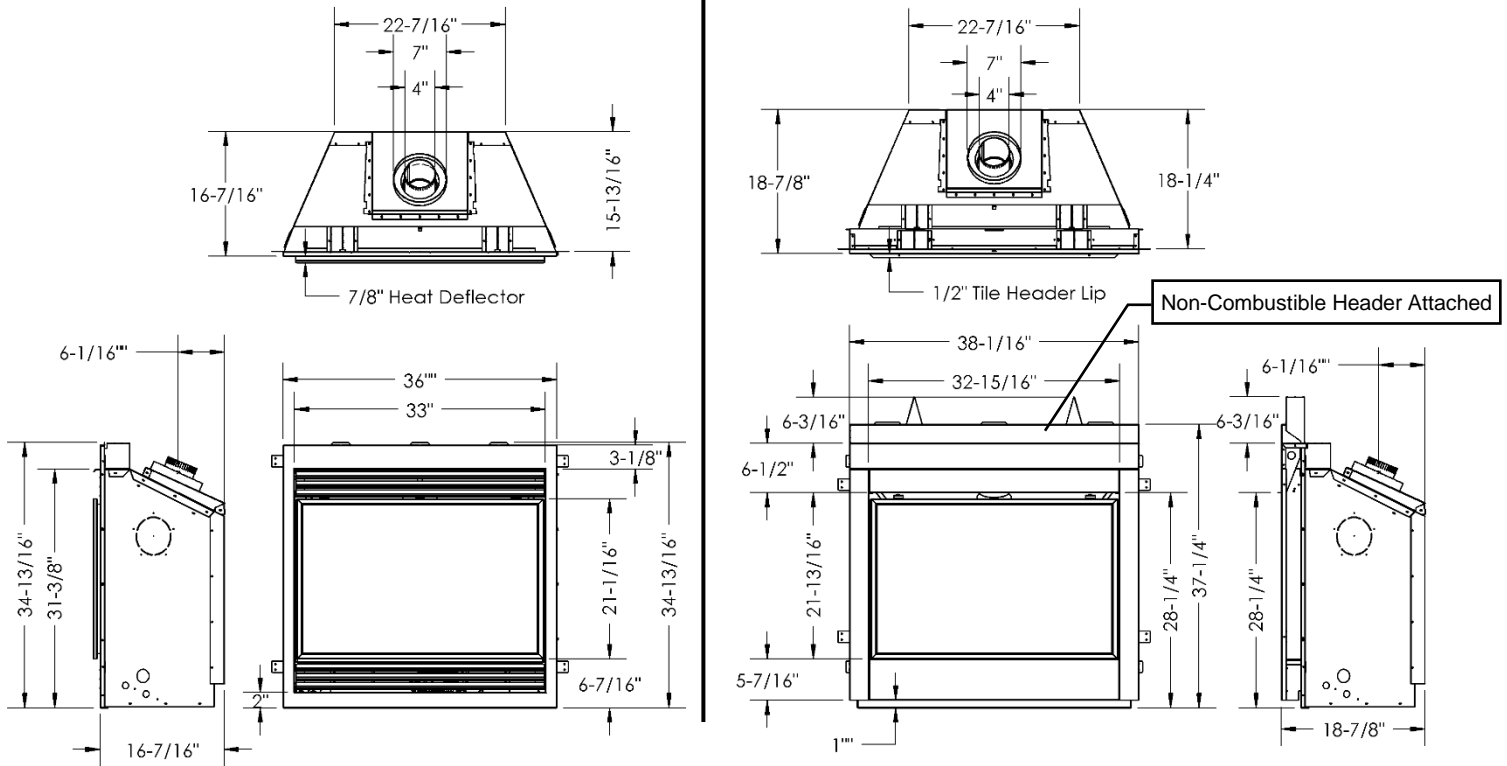

Vinyl Flooring- Luxury Vinyl Plank (LVP), Luxury Vinyl Tile (LVT), and other vinyl flooring can be sensitive to radiant heat and changes in temperature. We recommend a minimum 12-inch hearth should be installed, or the fireplace should be raised at least 24 inches above the floor. **The use of vinyl flooring is done at the installer's risk.**

Framing for your Gas Fireplace

Framing Specifications

1. Cold climate installation recommendation: When installing this fireplace against non insulated exterior wall or chase, it is recommended that the outer walls be insulated to conform to applicable insulation codes. Drywall must be installed over insulation to prevent contact of insulation and unit.
2. Choose fireplace location and frame in accordance with the fireplace framing dimensions specified (See Framing Diagrams). Bend nailing tabs forward on left and right of unit and place fireplace into framed enclosure. This allows for 1/2" in front of framing tabs for finishing materials.
3. Drywall or other material can extend flush with the appliance on the bottom, sides and top of fireplace. (louvered models only)

4. When installing horizontal with a 90 degree bend maintain a minimum of two and a half (2.5") inches above the bend in enclosures.
5. Hearth is not mandatory but is recommended for aesthetic purposes. For HBZDV with louvers combustible floor can raise 1" above the bottom of the fireplace. For HBZDV with CVCK (Clean view Circulating Kit) floor or hearth can raise 7" above the bottom of the fireplace with portions being combustible and non combustible. See drawing below.
6. When installing MQHB36SW surround, the fireplace must be raised a minimum of 3 1/2" above the finished floors, to accommodate the wall surround. The fireplace may be raised higher but the 60" clearance measured from the bottom of the fireplace to the ceiling must be maintained at all times. (i.e. For an 8ft ceiling, the unit can be raised only 36 inches.)

For **Propane Horizontal Installations** the venting must be a minimum of one foot vertical off the flue before the elbow on any horizontal runs of one foot or greater. This allows for cleaner combustion and greatly reduces carboning and cleaning of glass.

HBZDV36 Louvered

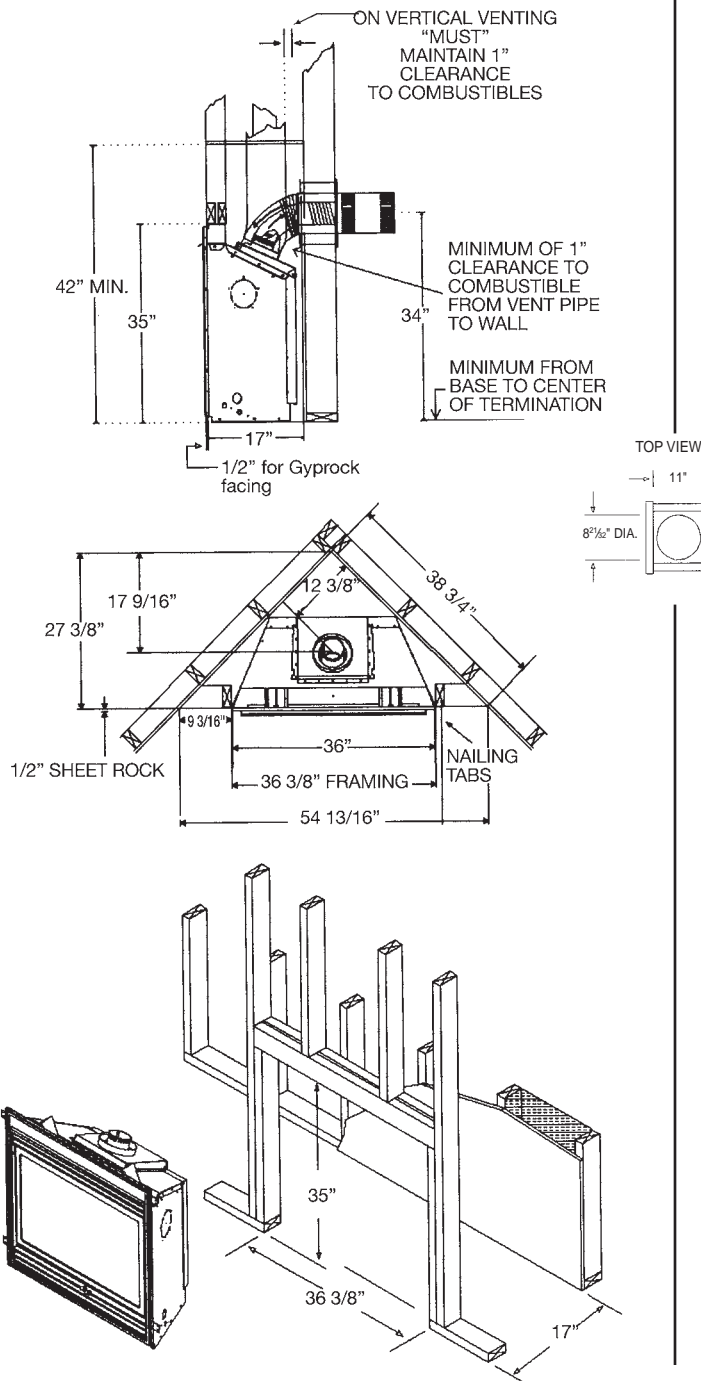

HBZDV36 WITH CVCK (CLEAN VIEW CIRCULATING KIT)

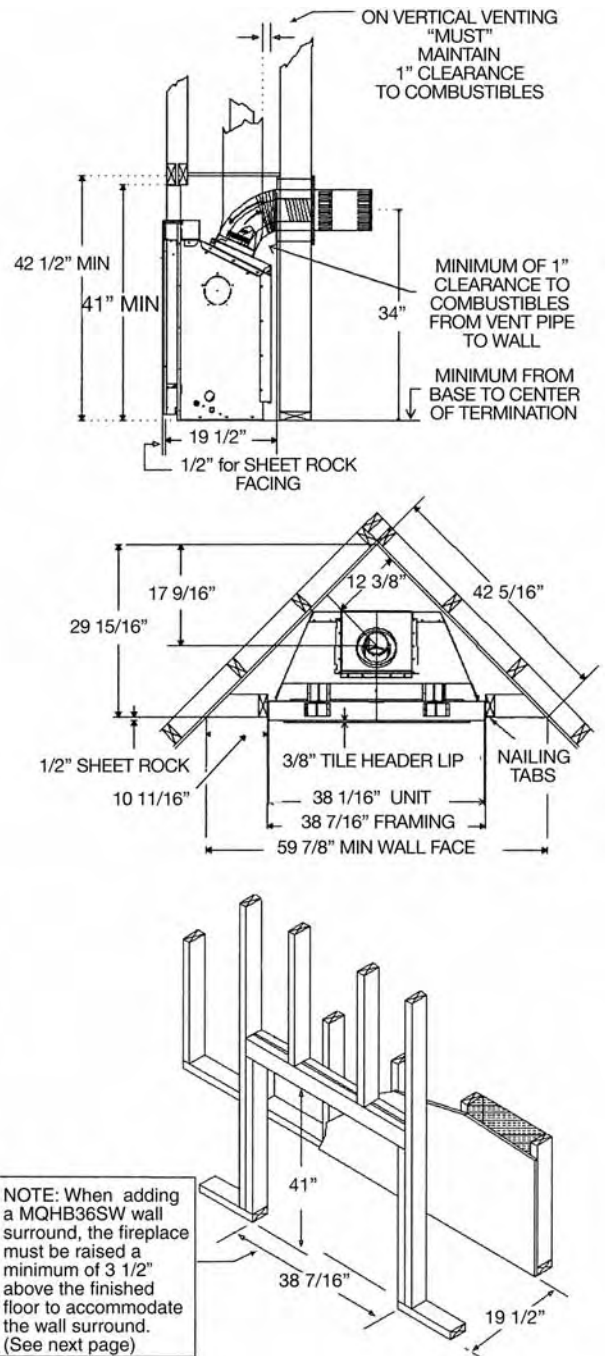

NOTE: When adding a MQHB36SW wall surround, the fireplace must be raised a minimum of 3 1/2" above the finished floor to accommodate the wall surround. (See next page)

HBZDV36 - Framing and Facing Requirements

HBZDV36 WITH HB36CVCK (CLEAN VIEW CIRCULATING KIT)

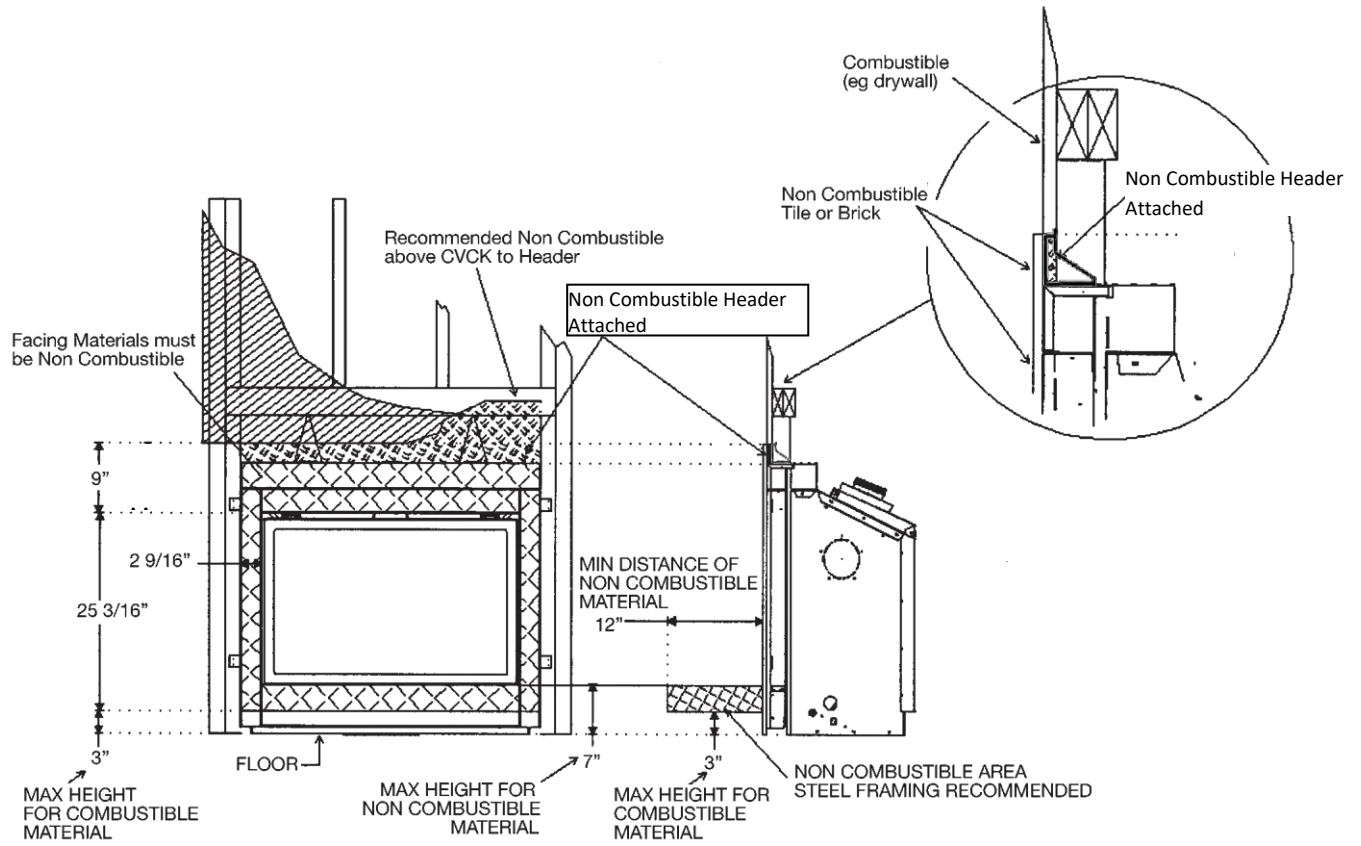

HB36 Clearance to Combustibles

Back (from Standoffs)	0 inches/0 mm
Side (from standoffs)	0 inches/0 mm
Floor	0 inches/0 mm
Ceiling (from bottom of fireplace)	60 inches/150 cm
Top (from standoffs)	0 inches/0 mm
Top of 90 degree bend in Minimum Enclosure of 42 to 43 inches	3 1/2 inches/89 mm / All Vent Systems
Top of 90 degree bend in Enclosure over 43 inches	2 1/2 inches/64 mm / All Vent Systems
Top of Horizontal Pipe	1 1/2 inches/38 mm / All Vent Systems
Side & Bottom of Horizontal Pipe	1 inch/25.5mm / All Vent Systems
Vertical Vent Pipe	1 inch/25.5mm / Kingsman Flex Vent Systems
Vertical Vent Pipe	1 1/4 inch/32mm / All Hard Pipe Systems

⚠ WARNING: Failure to position the parts in accordance with these diagrams or failure to use only parts specifically approved with this appliance may result in property damage or personal injury.

(NOTE -Floor) if installing the appliance directly on carpeting or other combustible materials other than wood flooring, the appliance shall be installed on a metal or wood panel, the full width and depth of the appliance. Carpet may extend 1 inch above the floor of appliance.

For units with CVCK (Clean View Circulating Kit) see framing with CVCK to establish floor heights.

HB36 - How to Install Clean View Kit (CVCK)

CVCK KIT CONTENT

- 1x Metal Surround
- 10x 1/2" DT Screws
- 4x #6 Combo Screws
- 1x 3" ON/OFF/PILOT Knob
- 1x 3" High/Low Knob
- 1x Non-combustible Header

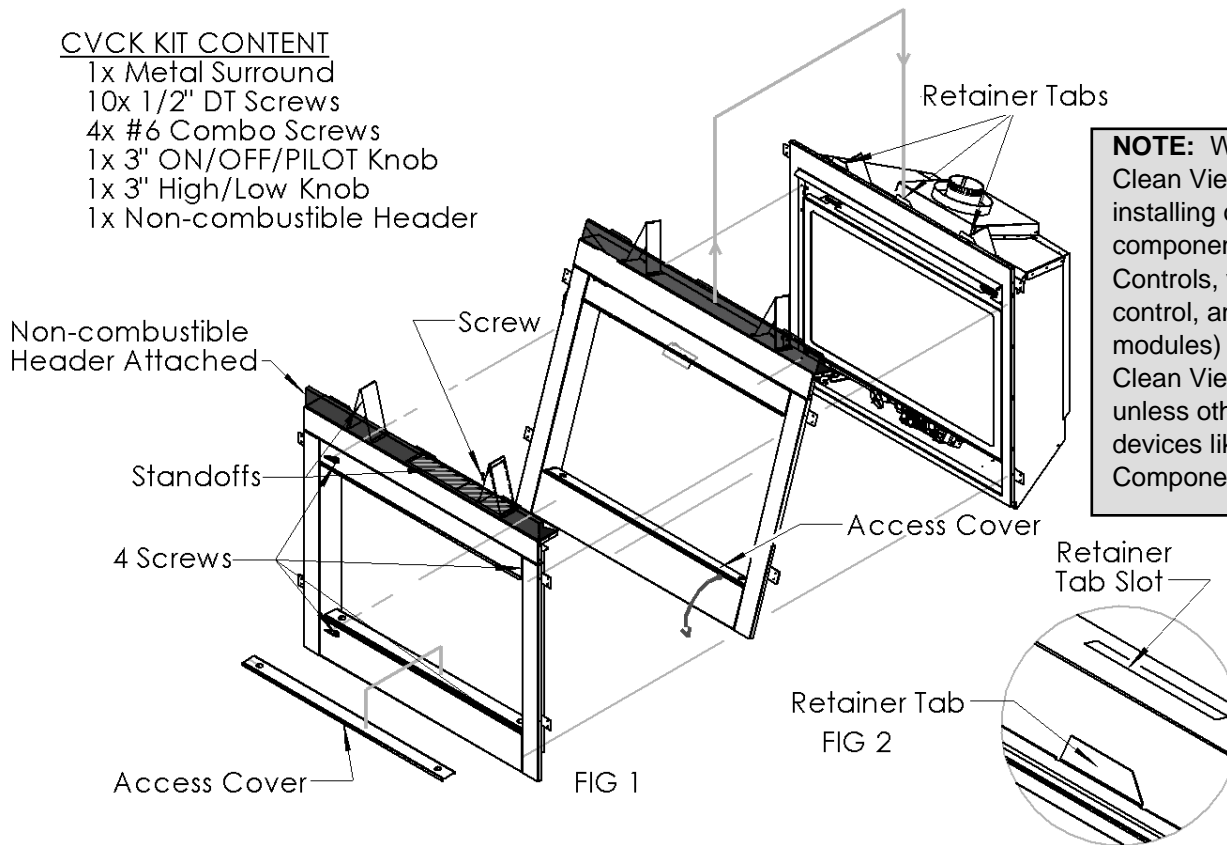

CAUTION: When using CVCK DO NOT INSTALL a Louver assembly.

1. Install optional fan kit (see Fan Instruction).
2. Fold two standoffs up into position and mount with supplied screws. (FIG 1)
3. Hang CVCK on top of fireplace retainer tabs and rotate down into position. (FIG 2)
4. **If not factory pre-installed**, use the screws provided to fasten the non-combustible header onto the top of the CVCK assembly.
5. Using four supplied #6 screws, fasten CVCK kit to the inside frame of unit.
6. Kit is supplied with 2 valve extension knobs. Align the notches and slide the extensions onto valve knobs.
7. DO NOT brick or tile beyond the inside area of the CVCK kit to allow for removal of door.

NOTE: ADDITIONAL ACCESS FOR GASLINE INSTALLATION AND FAN ELECTRICAL INSTALLATION- When CVCK is installed in framing, remove 2 screws from the right and left side of the bottom panel. Once screws are removed, bottom panel can be rotated forward for access to gas valve and fan system.

HB36SBL & HB42SBL Surrounds

Supplied with [Qty 4] 6-32 Black Self Tapping Screws.

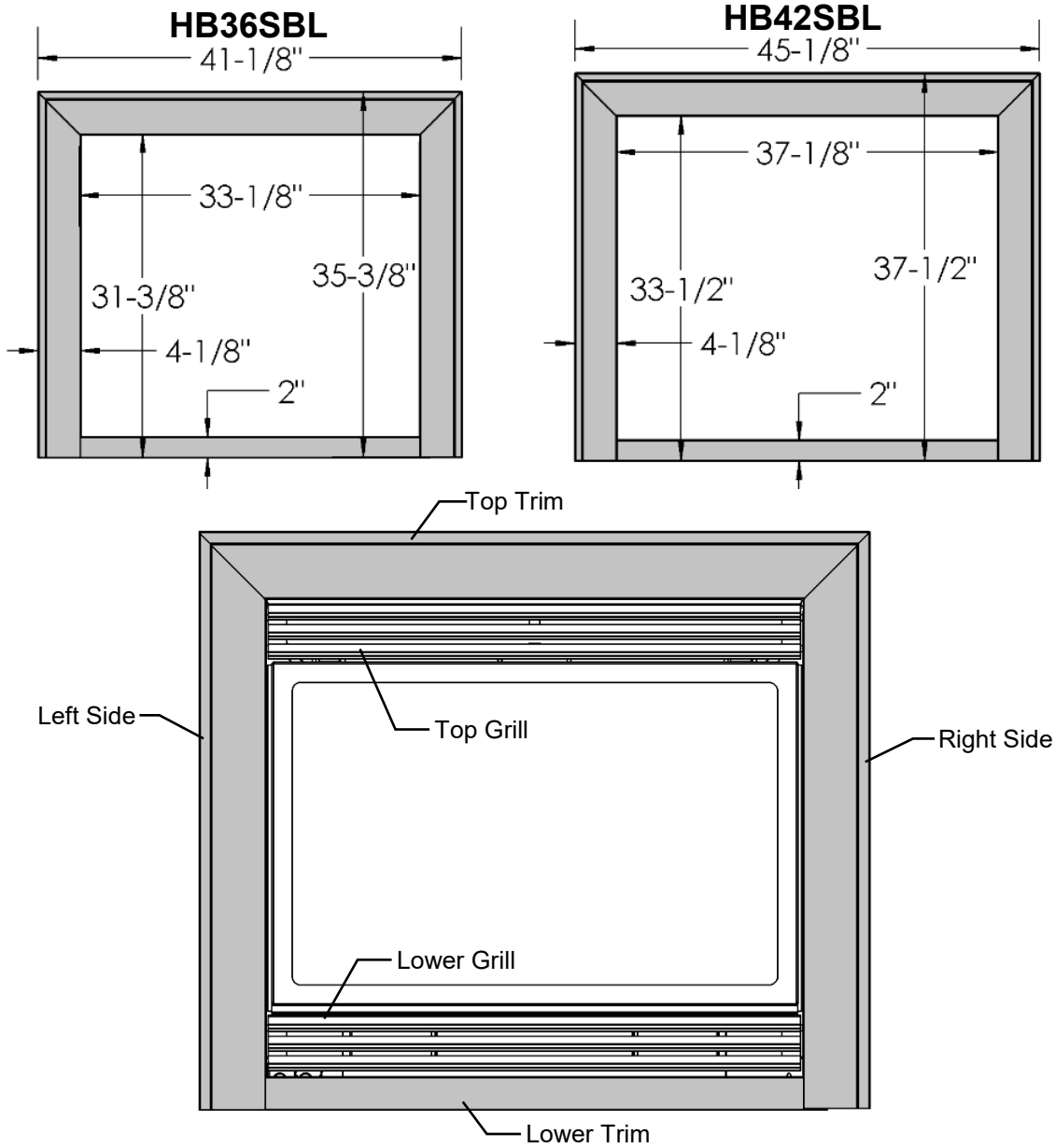

1. Remove Top and Lower Grills.
2. Place Lower Trim onto fireplace.
3. Attach left and right sides to fireplace with [2 ea.] 6-32 screws.
4. Position top trim onto left and right sides by sliding the top trim and bracket together.
5. Push bottom side of top trim toward fireplace. The lip on the bottom side of top trim must be inserted into fireplace.

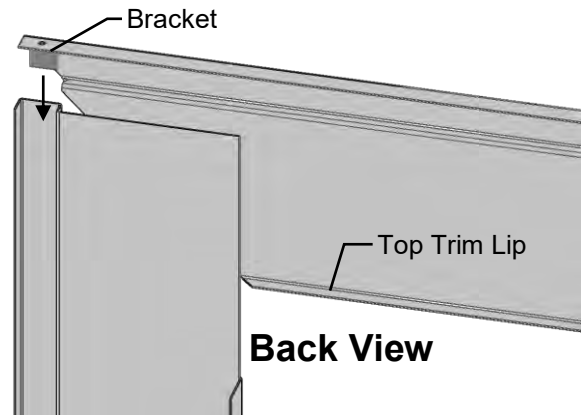

HB36 Mantel Clearances

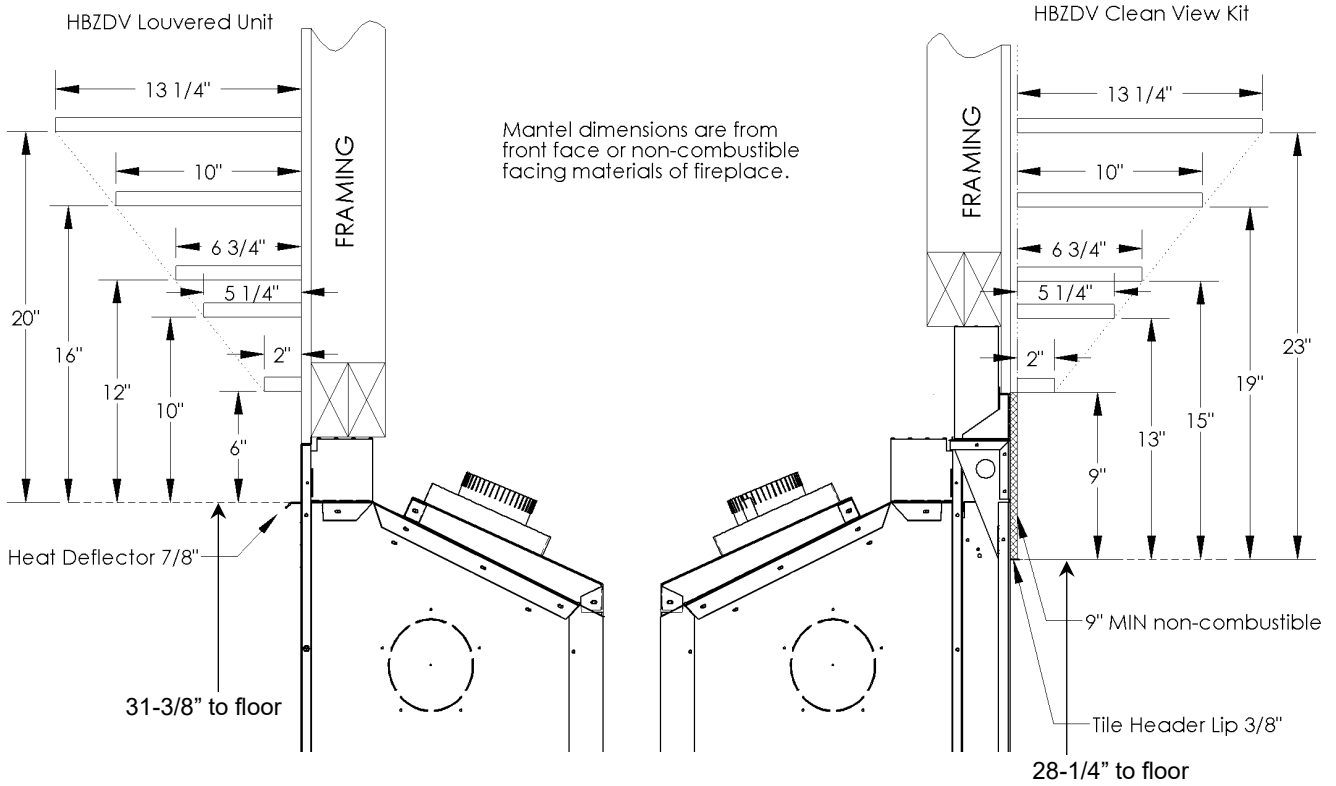

Warning: Combustible objects must not be placed on a non-combustible mantel unless the non-combustible mantel meets the minimum height and width requirements for a combustible mantel.

Mantel Leg Clearances

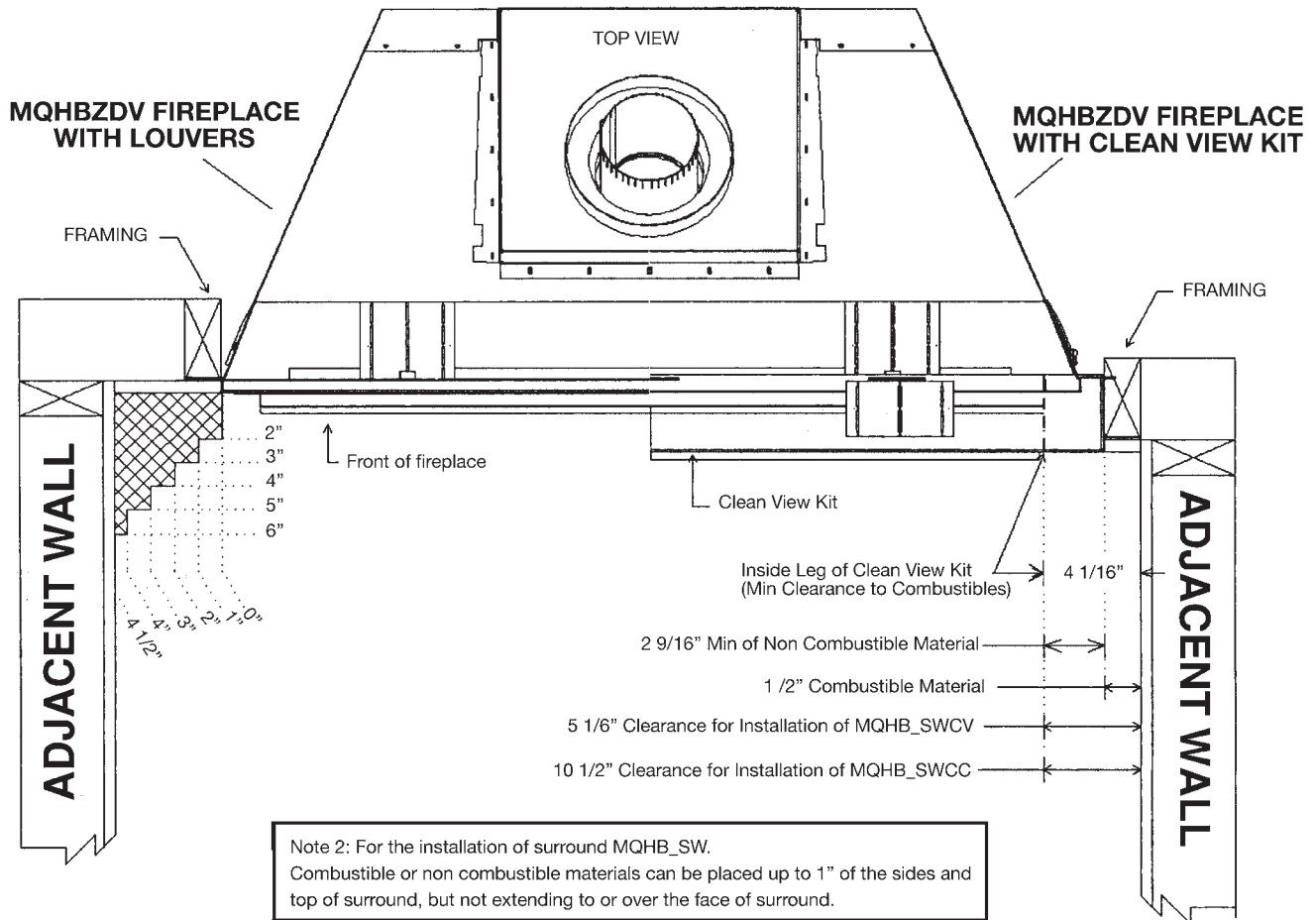

Mantels

Depending on the depth of the fireplace mantel, it may be installed higher or lower from the top of the fireplace opening. See drawings for proper installation height of your combustible mantel. Non-combustible mantels may be installed at any height above the fireplace opening except when using MQHBSW.

Non combustible materials such as brick, tile, etc. can extend up to or over the front face of the fireplace (NO PORTION OF GRILL AREA OR DOOR AREAS CAN BE COVERED) except where designer clean view kit is used.

Combustible material can extend flush to unit up to the top, bottom and sides of fireplace to stand-offs.

For COMBUSTIBLE materials extending in front of fireplace consult (Mantel and Mantel Leg Drawings).

Surrounds

If installing wide or slim line surrounds, the finish materials must be flush with the front facing of the fireplace.

Note: When using paint or lacquer to finish the mantel, such paint or lacquer must be heat resistant (250°F) to prevent discoloration.

Fan Installation for HBZDV 36/42/47

Fan Installation instructions for HBZDV36/42/47 with or without CVCK (Clean View Circulating Kit)

Note: INSTALL FAN KIT BEFORE INSTALLING OPTIONAL CVCK (Clean View Circulating Kit). If CVCK has been installed, additional access is provided by removing screws from bottom panel of CVCK.

Parts List:

- 1ea. Fan- comes with 4 ft cord. Two 14" leads (female ends)
- 1ea. Variable Speed Control (wall mount type)
- 1ea. Thermodisc
- 1ea. Thermodisc Mount Assembly

1. Slide fan housing into fireplace and place over the [2] Fan Retainer Tabs (Tabs are punched and bent up). Rubber grommets at the base of the fan should fit snugly over the tabs. **Note:** when installing fan, lay the fan on its back and slide into the fireplace lengthwise. Once inside the fan can be placed upright and slid behind the valve for placement.
2. Install the thermodisc. **Note:** HBZDV units have been installed with a sliding track system. Install the thermodisc provided with the fan kit into the sliding assembly (see **Fig.1** below). Next, attach the [2] wire leads exiting the right side of the fan housing into the thermodisc. Now slide the thermodisc assembly into the sliding track assembly (see **Fig.2** below). Place the swivel handle onto the sliding track assembly to lock it into position. To service the thermodisc, pull the swivel handle toward the front of the appliance.
3. Install the wall-mounted variable speed control into a junction box supplied with 120 volt power. Supply 120 volt power to the junction box with receptacle inside the fireplace. Plug the fan into the receptacle.
4. Turn the variable speed control clockwise to turn it on. Turn the fireplace on. Once the thermodisc in the fireplace reaches operating temperature (in approximately 10-15 minutes), the

fan will turn on. The fan can be switched off if desired by turning the variable speed control fully counterclockwise.

5. To set the minimum fan speed, remove the variable speed control from the wall mount. Turn the control to its minimum setting (fully counterclockwise). Use the adjustment screw on the side of the variable speed control to increase or decrease the minimum fan speed (lowering minimum fan speed will decrease the sound level created by the fan). Reinstall the speed control into the junction box and cover with face plate when finished.

Note: To service fan with CVCK kit installed see *Burner System Removal* section in manual.

Electrical Services: All optional fan kits are equipped with a 120V, 60Hz, .4amp blower. **Note:** All electric connections are to be made in accordance with CSA Standard C22.1 – Canadian Electrical code part I or with the National Electrical Code, ANSI/NFPA 70 (latest edition) and/or in accordance with local codes.

WARNING: Electrical Grounding Instructions: This appliance is equipped with a three-pronged (grounding) plug for your protection against shock hazard and should be plugged directly into a properly grounded three-prong receptacle. Do not cut or remove the grounding prong from this plug.

WARNING: Label all wires prior to disconnection when servicing controls. Wiring errors can cause improper and dangerous operation. Verify proper operation after servicing.

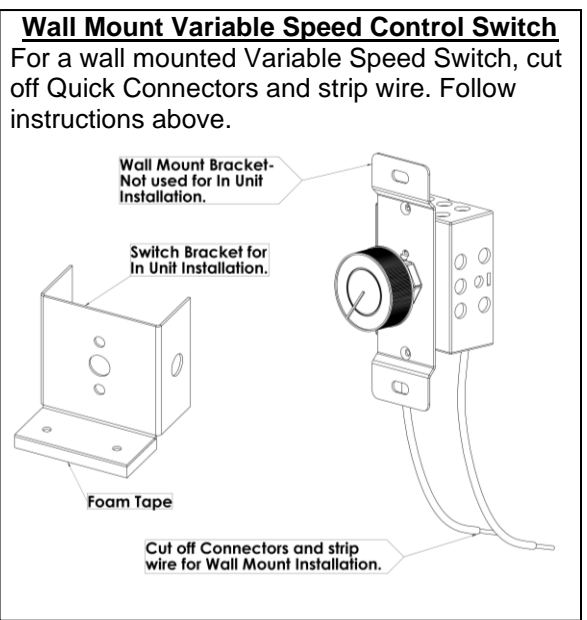
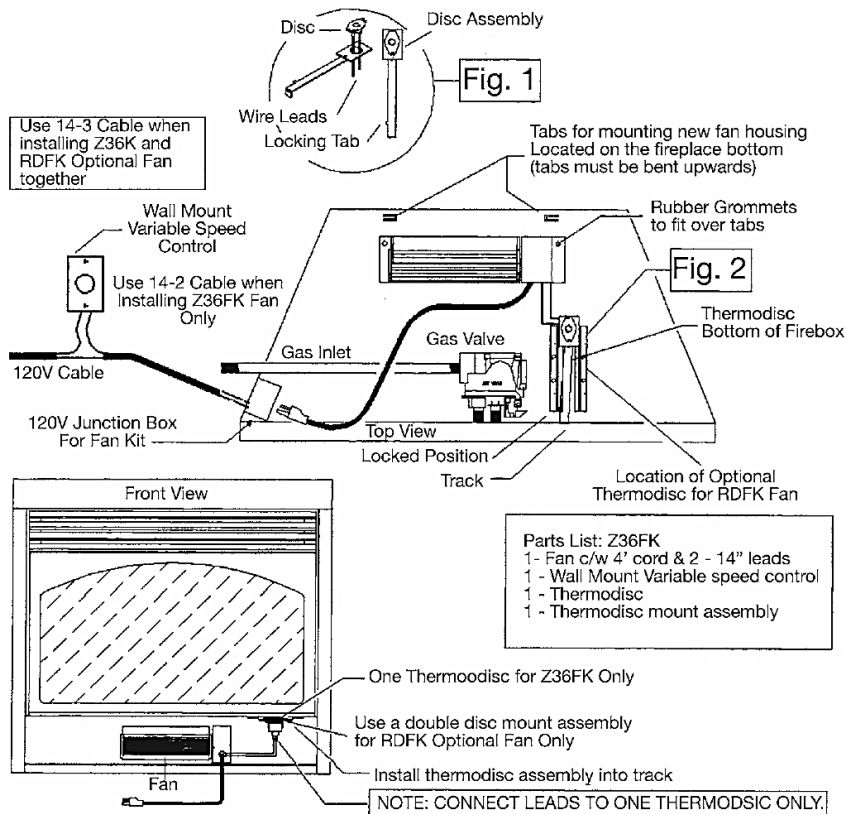

CAUTION – DO NOT ATTACH 120V FAN ASSEMBLY TO MILLIVOLT GAS VALVE SYSTEM

Split Receptacle- Fan Speed Control Outside of Fireplace

If you plan to locate the variable speed control switch for the fan outside of the fireplace and you require a constant source of AC power inside the unit for another accessory such as lights or an IPI valve system, follow one of the procedures below.

⚠️ WARNING

A qualified electrician must connect electrical wiring to junction outlet for built-in installation.

Follow all codes.

⚠️ WARNING

Electrical Grounding Instructions –
This appliance is equipped with a three – pronged (grounding) plug for your protection against shock hazard and should be plugged directly into a properly grounded three-prong receptacle.

⚠️ WARNING

Label all wires prior to disconnection when servicing controls. Wiring errors can cause improper and dangerous operation. Verify proper operation and servicing.

⚠️ Caution: Electrical installation to be done by a qualified installer. All wires must be connected and grounded in accordance with CSA Standard C22.1- Canadian Electrical Code part 1 or with the National Electrical Code, ANSI /NFPA 70 (latest edition) and /or in accordance with local codes.

Switch Controlled Split Receptacle With Switch At START Of Cable Run

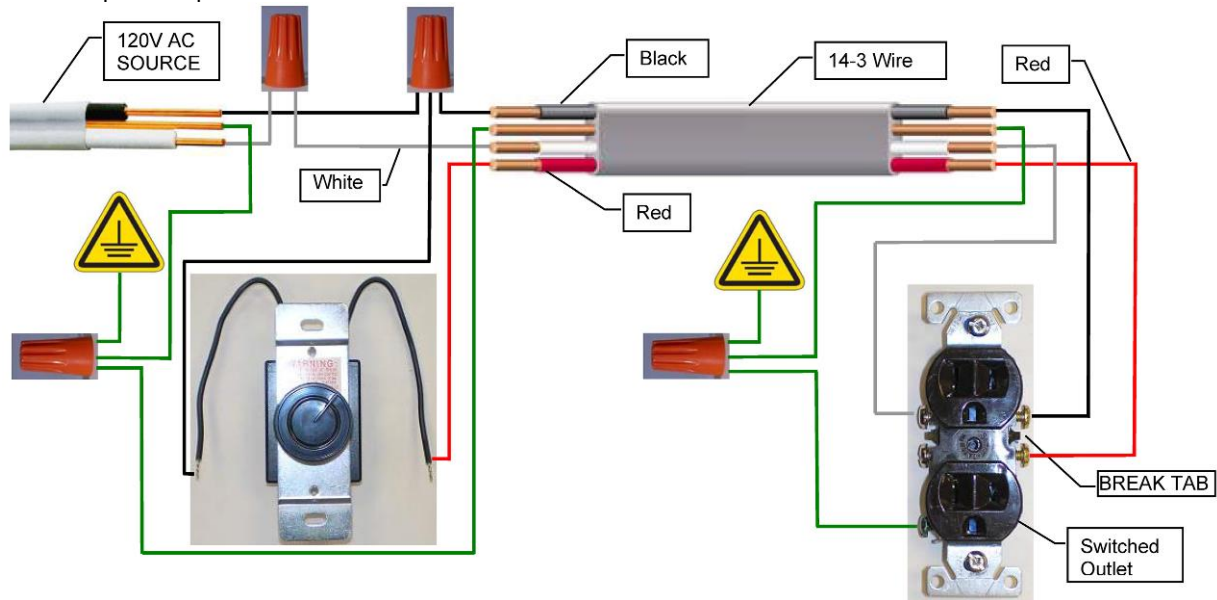

Switch Controlled Split Receptacle With Switch At END Of Cable Run

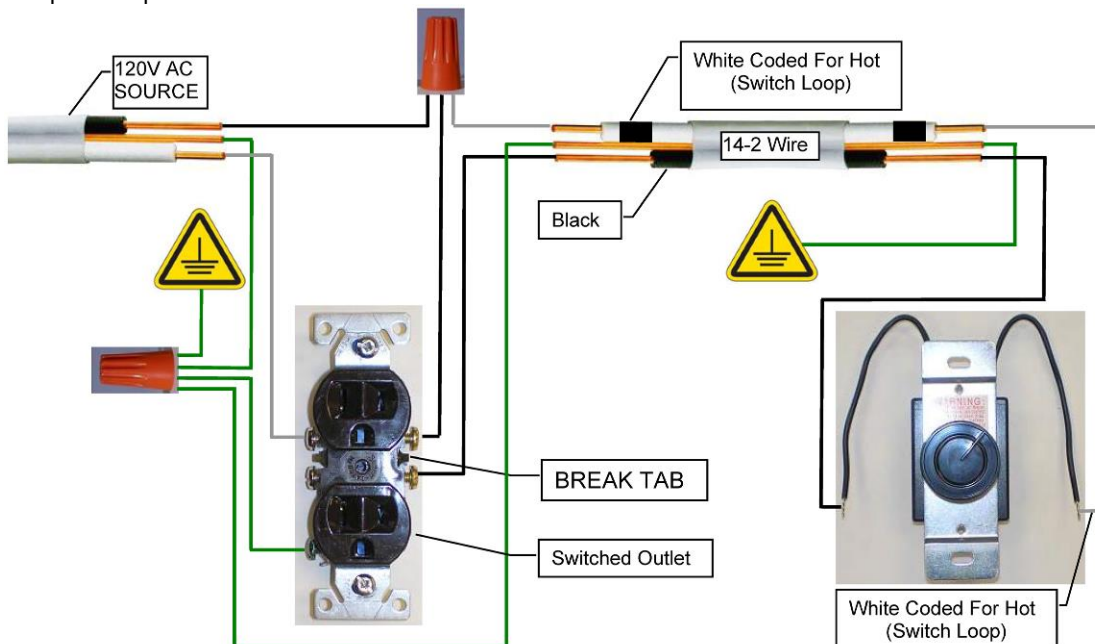

Brick Liner Installation – HBZDV3624 & HBZDV3628

INSTALLING BRICK PANELS FOR MODEL HBZDV3624 AND HBZDV3628

1. Place rear brick panel against rear of fireplace.
2. Loosen screws holding brick clips in position. Rotate clips up out of the way.
3. Place bottom of side brick over front lip of fireplace and rotate panel into position.
4. Rotate brick clips down and tighten screws.

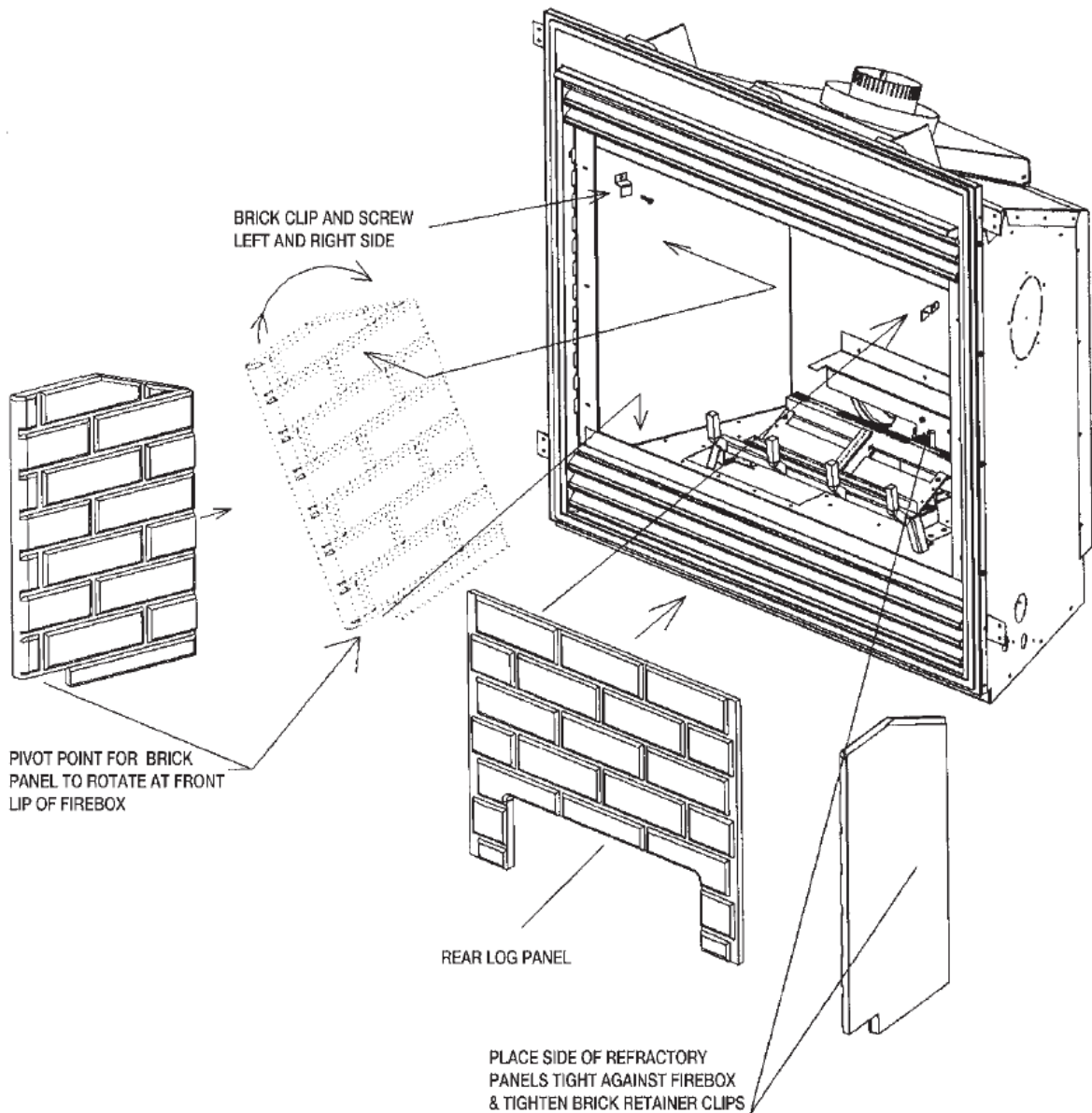

Installation of HB Porcelain Liners - HB36PL

1. Remove Door from the fireplace by unlatching the 2 latches on top of unit.
2. Remove back Log Holder by removing 3 screws from face of Log Holder. The Log Holder will have to be re-installed after the placement of the Back Panel.
3. Place Back Panel up against rear of firebox by tilting top of Back Panel towards you and sliding bottom of Back Panel over burner system.
4. Loosen screws holding Brick Clip in place. Rotate Brick Clip out of the way and slide Side Panel up against Back Panel. Side Panel tabs should engage top and bottom of Back Panel (**See Ref. 3**). Rotate Brick Clip down over Side Panel and tighten screw.
5. Re-install Log Holder (and Brick Filler Panel if applicable) removed in step 2. Install Log Set as per instruction and re-install Door.

Parts List:

- 1 Left Side Panel
- 1 Right Side Panel
- 1 Back Panel
- (**HB47PL ONLY**) 1 DT Screw

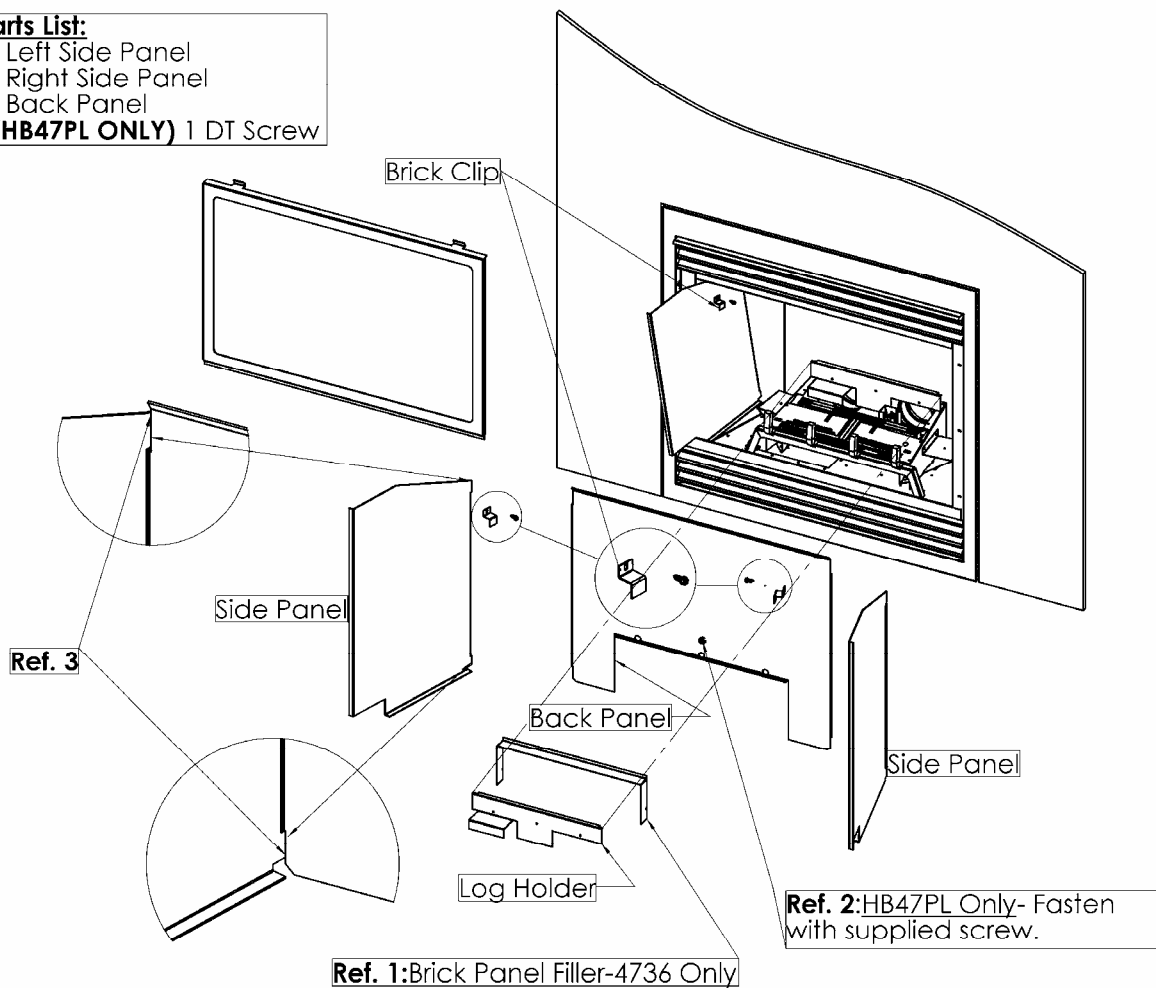

Door and Glass Information

Glass Cleaning

It will be necessary to clean the glass periodically. During start-up, condensation, which is normal, forms on the inside of the glass and causes dust, lint etc. to cling to the glass surface. Also, initial paint curing can deposit a slight film on the glass. It is therefore recommended that initially the glass be cleaned two or three times with non-abrasive common household glass cleansers and warm water. After that, the glass should be cleaned two or three times a season depending on the circumstances.



Warning and Cautions.

- Do not clean when the glass is hot.
- Do not use abrasive cleaners.
- Using a substitute glass will void all product warranties.
- Do not strike or abuse glass. Care must be taken to avoid breakage of the glass.
- Do not operate this fireplace without the glass front or with a broken glass.

Glass Replacement

REPLACEMENT GLASS FOR BOTH DIRECT VENT UNITS

Model Series HBZDV3624 can use either tempered glass or Robax ceramic or coated Neoceram glass. Must be 5mm thick.

Only Robax ceramic or coated Neoceram glass may be used for replacement for model HBZDV3628. Must be minimum 5mm thick.

To replace glass, clean all materials from door frame. Scrape off old silicone down to metal. Using a high heat silicone temperature-resistant to 500°F (260°C) apply a continuous bead of approximately 1/32" to all four sides of frame and insert glass with new gasket. Frame should be on flat surface, with a small amount of weight pressing glass into silicone. Let dry approximately 15 to 20 minutes. The door can be re-installed by reversing Steps 1 & 2. Use caution when removing broken glass, wear gloves.

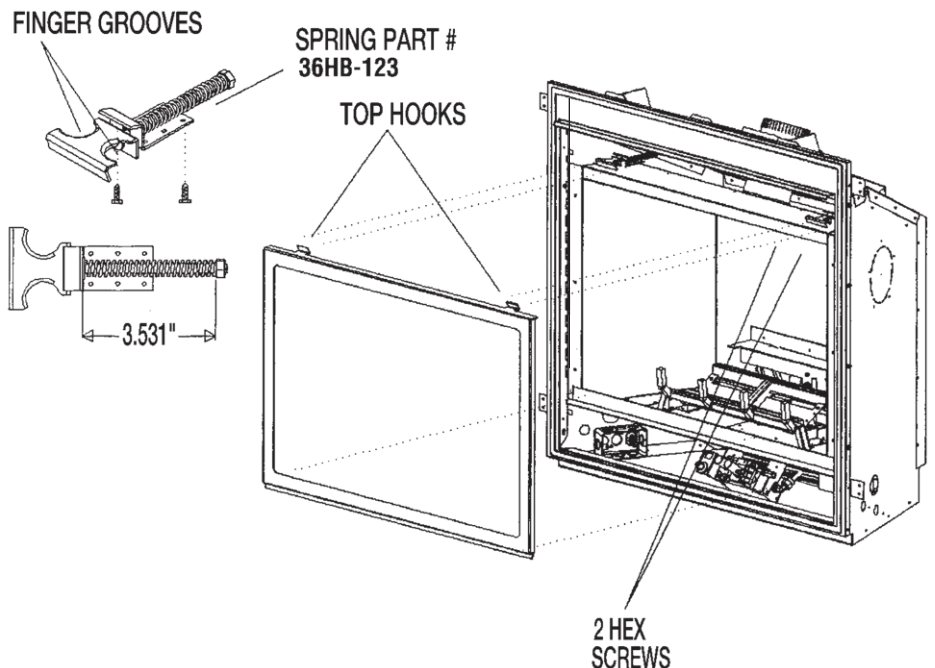

Removal of the Glass Door

1. Remove the door by unlatching the 2 top latches. Simply place 2 fingers in the grooves, pull towards you and lift upwards slightly.
2. Once the top of the door is unlatched, simply pull outwards and lift upwards to unlatch the bottom.
3. When re-installing the door place the bottom of the door in first and secure with Top Latch assembly to the door.

Spring Replacement:

*Over time, spring may need to be replaced if tension is lost.

1. To remove the top latch, remove the 2 hex screws that secure it in place. They are located in the firebox.
2. Once all the screws are removed the latches will slide out of place.
3. There is 1 lock nut per latch. When replacing a spring, tighten the lock nut until 2 threads are beyond the locknut. This is critical for proper tension.

Appliance/Log Reference Chart/Log Placement

The following is a list of models and appropriate log sets that can be used with each model. It is important that the appropriate log set is used with the correct model in order for the appliance to work properly.

Appliance	LOGF36	LOGC42	LOGC43	LOGC44	MQLOGC45	MQRSP2 MQROCK1	MQRSP3 MQROCK1
HBZDV3624N or LP		✓	✓	✓	✓		✓
HBZDV3628N or LP		✓	✓	✓	✓		✓
MQHBZDV3636N or LP	✓					✓	

Log Placement - LOGF36 for MQHBZDV3636



WARNING: Failure to position the parts in accordance with these diagrams or failure to use only parts specifically approved with this appliance may result in property damage or personal injury.



Parts List

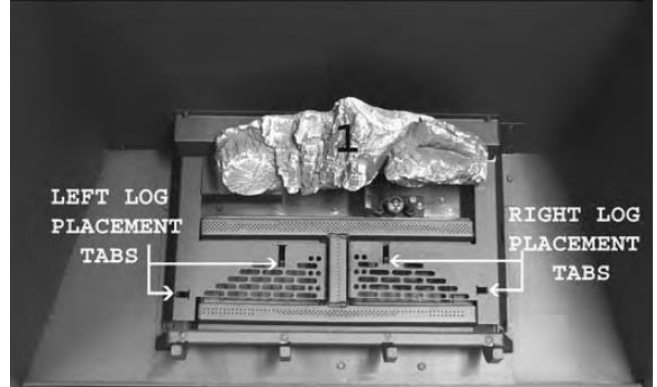

STEP 1: Place log #1 onto rear log holder and center.



STEP 2: Place log #2 onto left side of log. Place log #3 onto right side of log #1.



STEP 3: Locate 2 holes on the bottom of logs #4 and #5. Position them onto left and right log placement tabs.



STEP 4: Locate the hole on the bottom of log #6. Place onto the mounting tab on log #2. Locate the 2 holes on the bottom of log #7. Place onto mounting tabs on log #5.



STEP 5: Place glowing embers on the front of the burner tube and ember plates. Place lava rock on the burner pan as shown. **DO NOT PLACE LAVA ROCK ON BURNER TUBE.**

NOTE: THESE COMPONENTS ARE SUPPLIED WITH THE FIREPLACE.

Lava Rock



Insulation Wool



Embers

⚠ WARNING: Failure to position the parts in accordance with these diagrams or failure to use only parts specifically approved with this appliance may result in property damage or personal injury

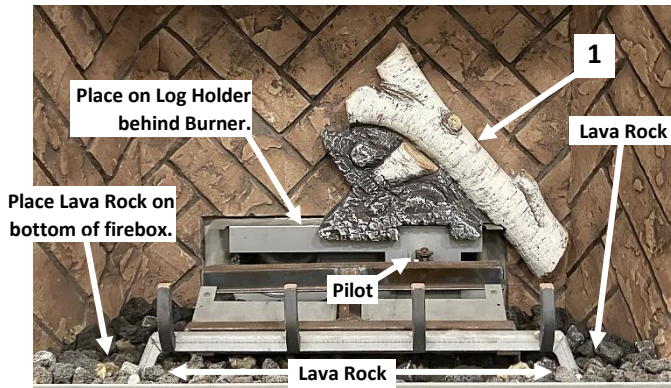

Log Assembly for HBZDV3624/HBZDV3628 LOGC42 - LOG C43 LOG PLACEMENT GUIDELINES (4-PIECE LOG SET)



FIGURE A - Log set Ember kit and Crushed rock

WARNING:  Failure to position the parts in accordance with these diagrams or failure to use only parts specifically approved with this appliance may result in property damage or personal injury.

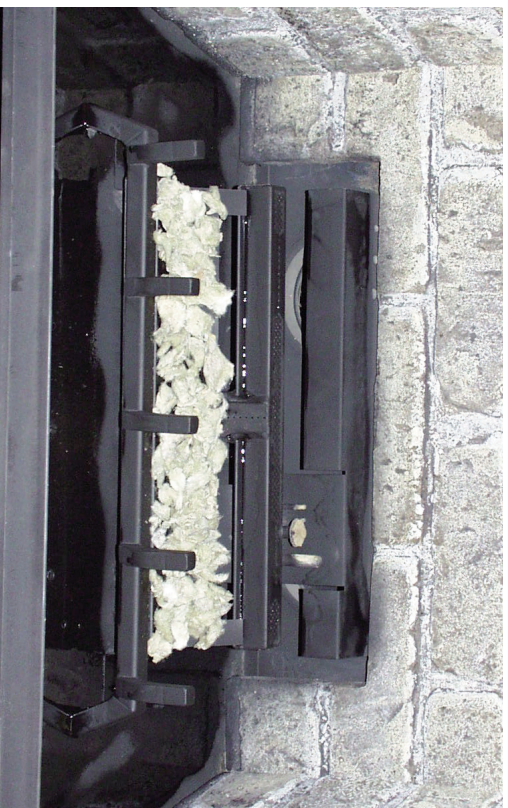

Step (4) Break glowing embers into thumbnail size. Place glowing embers on to the surface of the front burner, to the surface of the ember plates and over crossover to the same height as ember plates. Height on front burner 1/2" to 3/4". Height on ember plates 3/4" to 1". Do not cover back air openings on ember plates.



Air
Opening

Ember
plate

FIGURE B - Rear log holder.

Step (1) Units are equipped with screws or latches. To remove glass door, either remove screws or unfasten latches and lift door off bottom door retainer.

Step (2) Remove logs from carton and inspect each log.

Step (3) Verify to see that the ember plates (2 pcs) are between front and back burner.



Step (5) Place front log over burner, against decorative grate. Be sure that front log is tight up against the decorative grate.

LOG C42 - LOGC43 LOG PLACEMENT (continued) - FOR MODELS HBZDV/3624/HBZDV/3628



Step (6) Place rear log on to the log retainer 1/2" away from back of fireplace. (If refractory liner is used, make sure refractory liner is installed first then back log is to be pushed up against it as tight as possible.)



Step (7) Place right crossover log across front and back logs using the log placement pin as a guide.



Step (8) Place left crossover log across front and back logs using the log placement pin as a guide.



Step (10) Purge lines and test pilot operation.
Step (11) Replace glass door.

Step (9) Place decorative moon rock on bottom of fireplace to simulate ash.
DO NOT PUT ANY ROCK ON BURNERS!

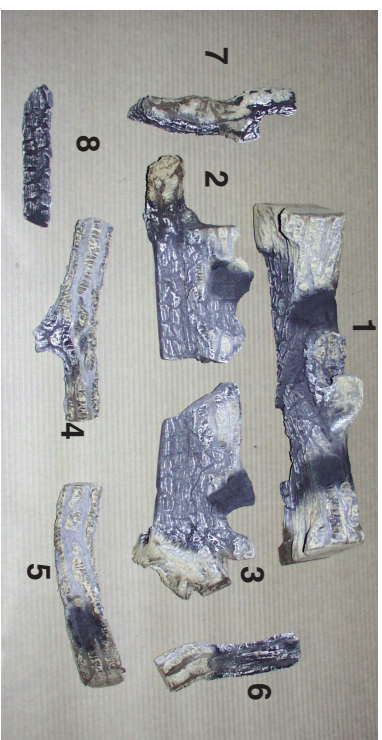
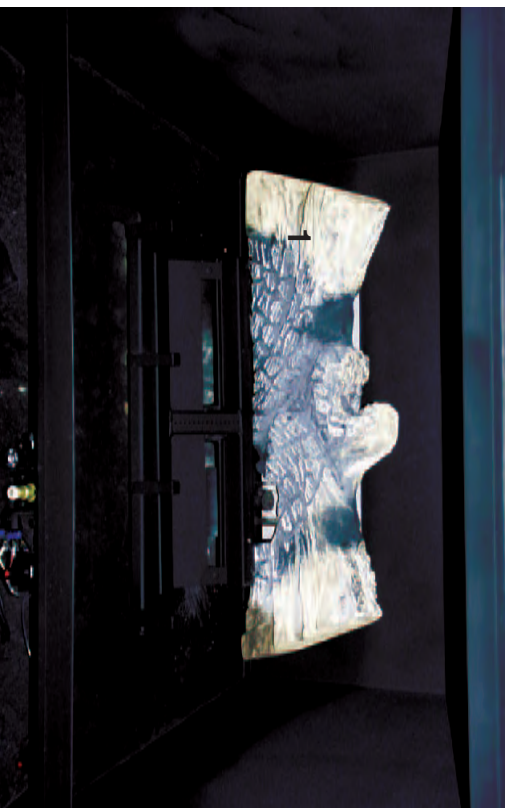
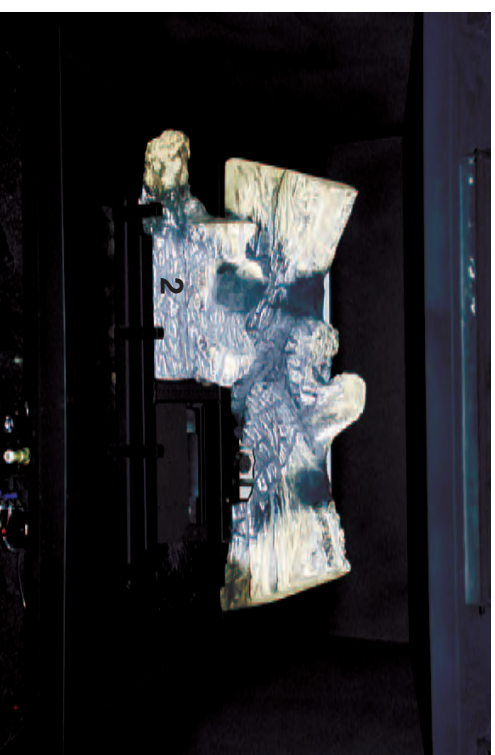

FIGURE A - Log set Ember kit and Crushed rock



Step (1) Position rear log over rear log holder and lower into position. Be sure that the log does not sit on rear burner, but behind and lower than burner.



Step (2) Locate flat surface on Log (2) and place directly onto left ember plate; push log fully to the right until it touches the crossing tube.

LOGC44 PLACEMENT GUIDELINES - FOR MODELS HBZDV3624/HBZDV3628



Step (3) Locate flat surface on Log (3) and place directly on to right Ember plate, push log fully to the left until it touches Log (2)



Step (5) Position Log (4) into grooved areas of Logs (1) and (2).

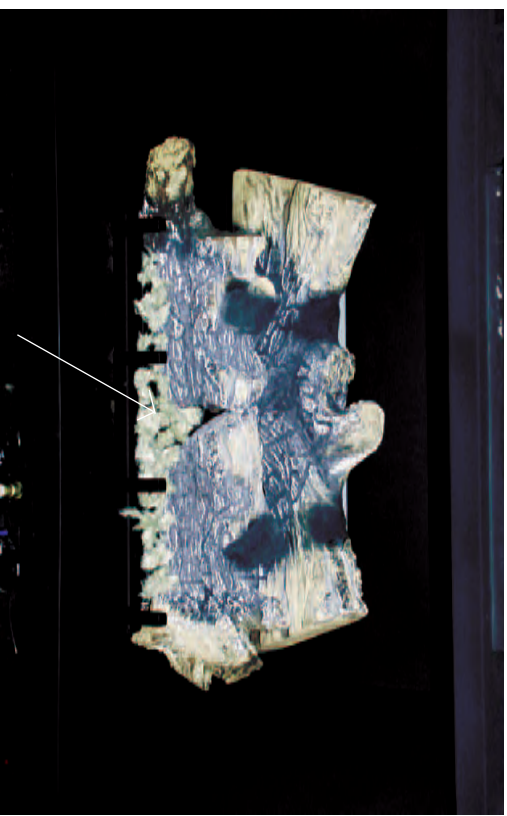

Step (4) Remove Ember material from plastic bag, tear off dime and nickel sized pieces and place directly onto front burner tube and crossover tube. (NOTE: Do not place embers onto rear burner tube)

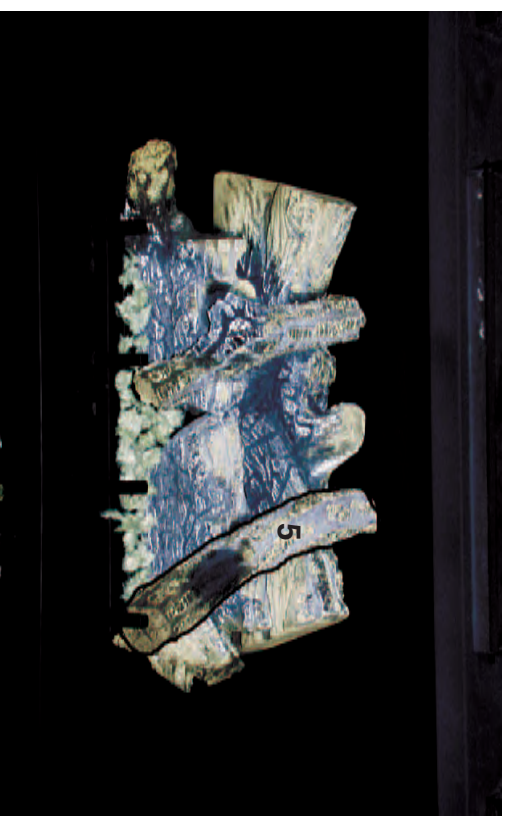

Step (6) Position Log (5) into grooved area of Logs (1) and (3).

LOGC44 PLACEMENT GUIDELINES - FOR MODELS HBZDV3624/HBZDV3628



Step (7) Position Log (6) up against the the 2nd grate post from the right, and position upper section of Log (6) into grooved area of Log (5).



Step (9) Position Log (8) up against the 3rd grate post from the right, and position upper section of Log (8) against Logs (2) and (7).



Step (8) Slide Log (7) between Log (1) and Log (2)



Step (10) Place crushed rocks onto firebox bottom.
(NOTE: Do not place crushed rock onto burner tubes)

Note: If flame impingement on the rocks causes sooting, you may have to move or remove one or more rocks. Do not place rocks directly over top of the burner tube.

MQLOGC45 Oak Logset -Placement Instructions- HBZDV3624 / 3628 / 4224 / 4228

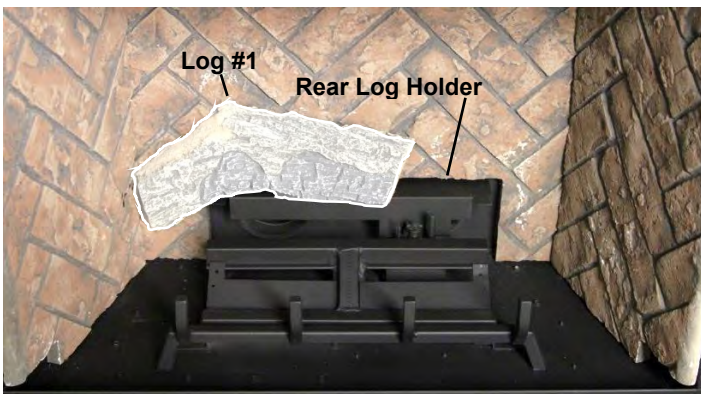

Step 1: Place flattened area of **Log #1** onto left side of Rear Log Holder.

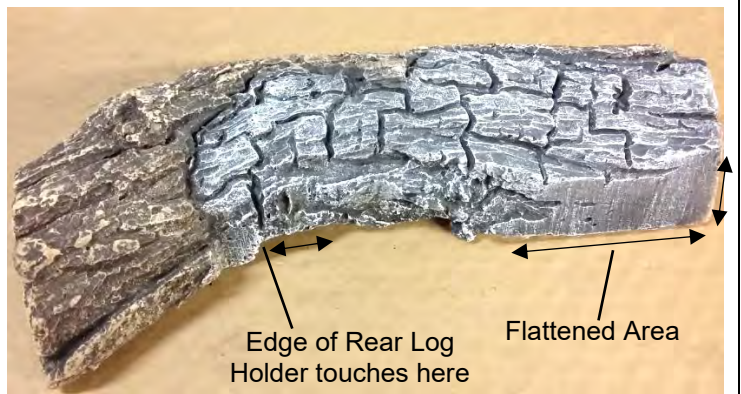

Log #1 Flattened Area

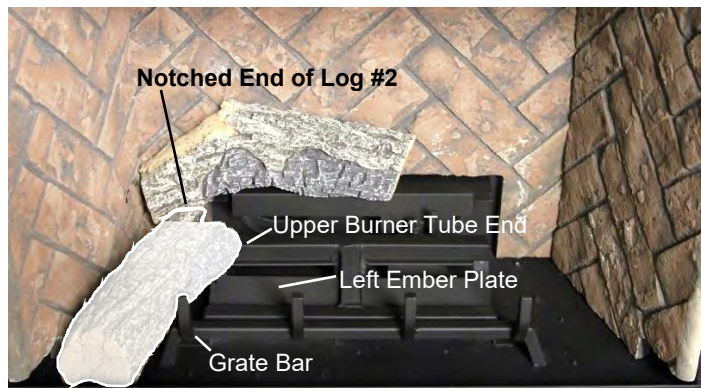

Step 2: Place Notched End of **Log #2** onto Left Ember Plate and against Upper Burner Tube End. Next place Flattened Area of Log #2 onto Firebox Floor and against left side of Grate Bar.



Step 3: Rest the Small Branch end of **Log #3** onto Rear Log Holder. Next place Flattened area of Log #3 onto firebox floor between the right end of Grate Bar and sidewall of Firebox or Brick Panel.

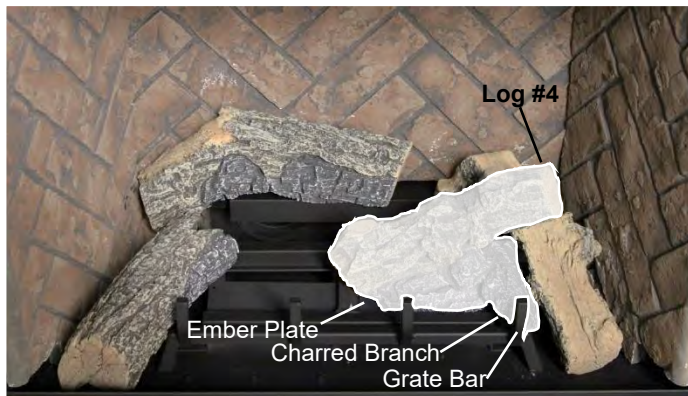

Step 4: Place Flattened Area of **Log #4** onto the Ember Plate, making sure it is completely seated. The charred Branch of Log #4 will rest on the end of the Grate Bar.



Step 5: Place Rock Wool onto Front and Crossover Burner Tubes and onto the Left Ember Plate



Step 6: Place the end of **Log #5** against middle right Grate Bar as shown. The other end will rest on Log #2.



Step 7: Place **Log #6** onto Log #1 and Log #5 making sure to position between the end and center flames evenly. There should be no impingement of flames or sooting may occur.



Step 8: Place **Log #7** onto empty spot on Rear Log Holder and onto Log #4 making sure to position between the end flame and center flame evenly. There should be no impingement of flames or sooting may occur.

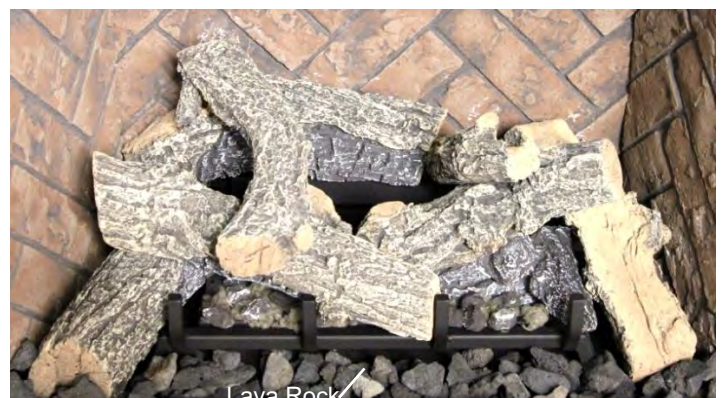

Step 9: Place Lava Rock onto Firebox Bottom.

MQRSP3 with Pilot Shield

⚠ WARNING:

Failure to position the parts in accordance with these diagrams or failure to use only parts specifically approved with this appliance may result in property damage or personal injury.

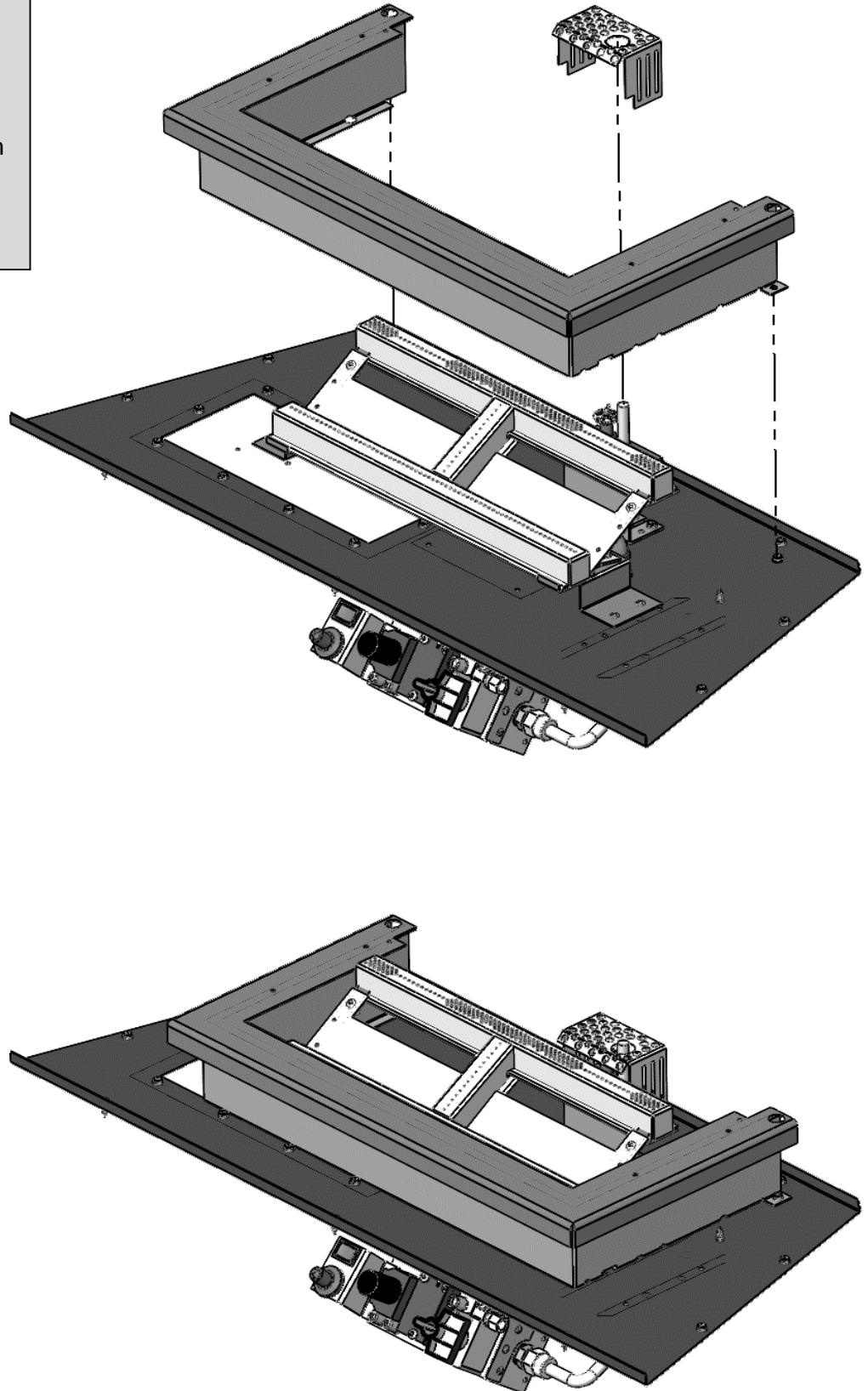

Installing MQRSP3 Rock Platform Assembly - Fits HBZDV3624-28/4224-28



WARNING: Failure to position the parts in accordance with these diagrams or failure to use only parts specifically approved with this appliance may result in property damage or personal injury.

Installing rock platform to burner system with pre-punched holes:

1. Remove the two factory installed screws located at the back of burner system.
2. Center platform on burner system.
3. Fasten rock platform with screws removed in step 1.

Installing rock platform to burner system without pre-punched holes:

1. Use the rock platform as a template for the holes to be drilled. Center platform on burner system 1" from the back of firebox (Ref 1) and mark the location of holes to be drilled.
2. Using a 1/8" drill bit, drill holes marked in step 1 and fasten rock platform with the two supplied screws.

Packaging MQRSP3
 2 - 8-18 DT Screws
 1 - Rock Platform
 1 - Instructions

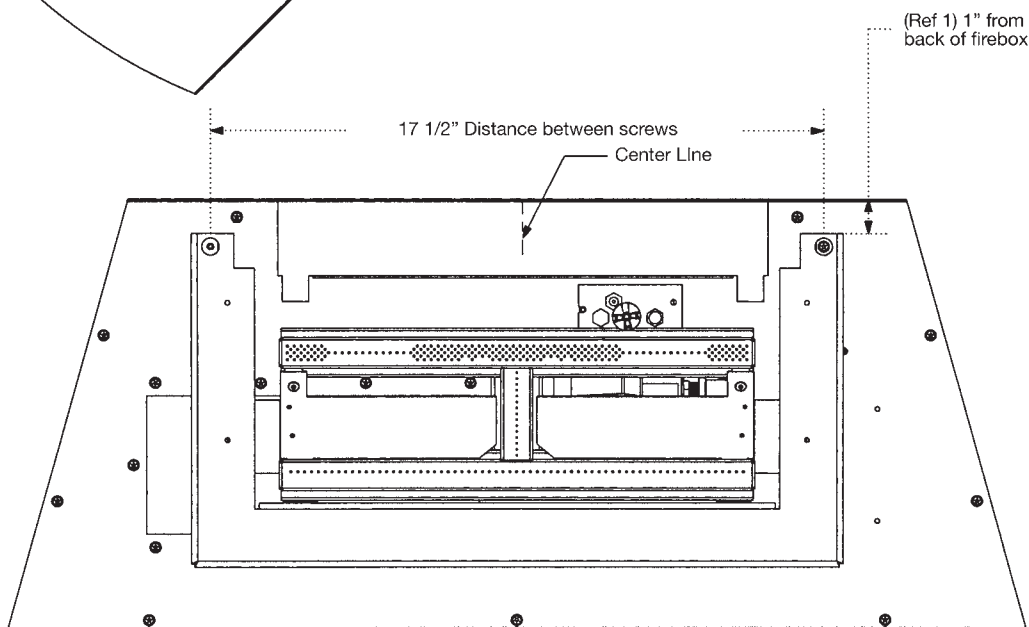
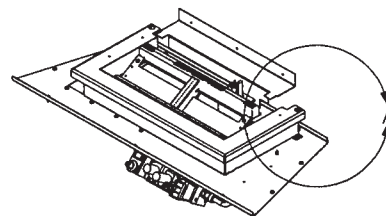
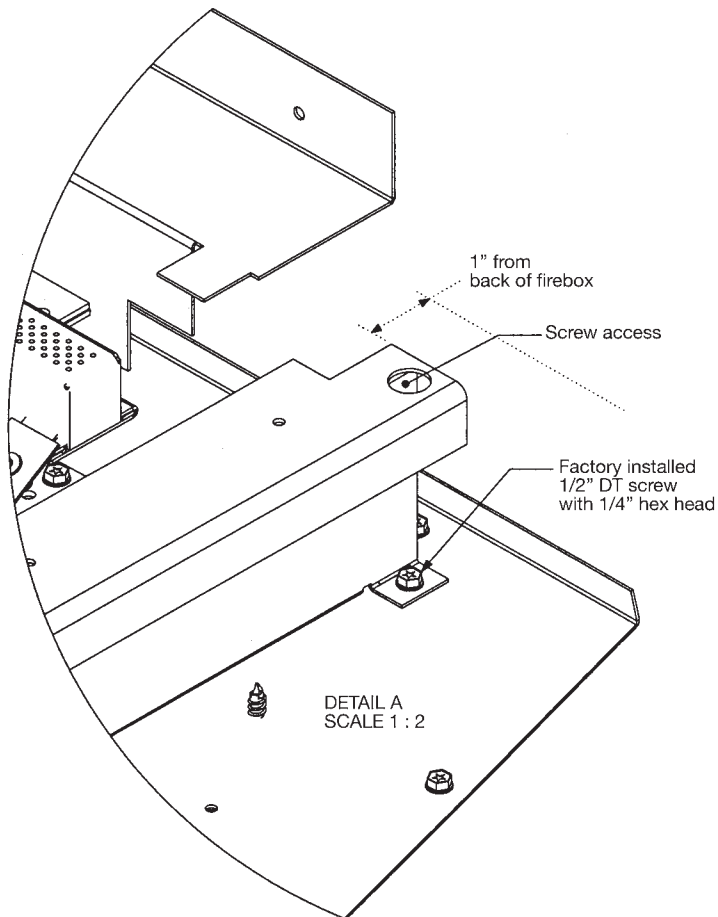

Pilot Shield RSP1 / RSP2

Qty: 1 Shield Per Kit

1

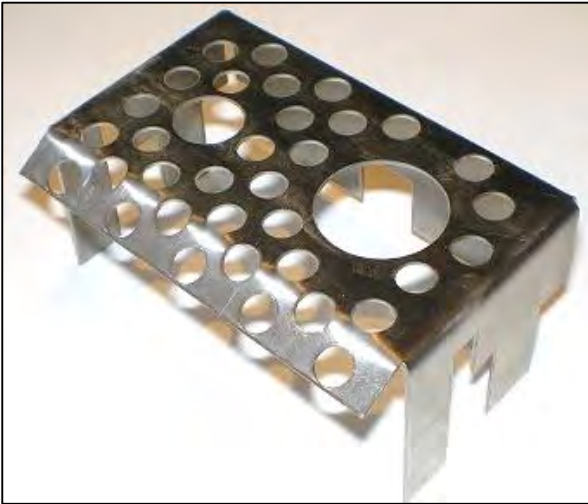

2

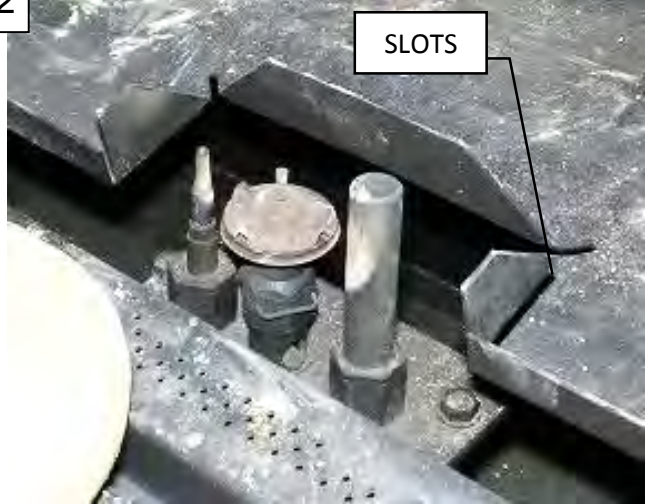

3



4

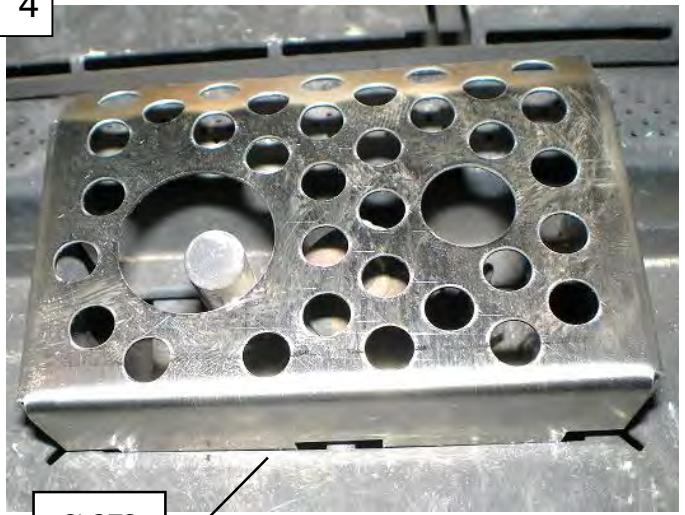

Back View

5

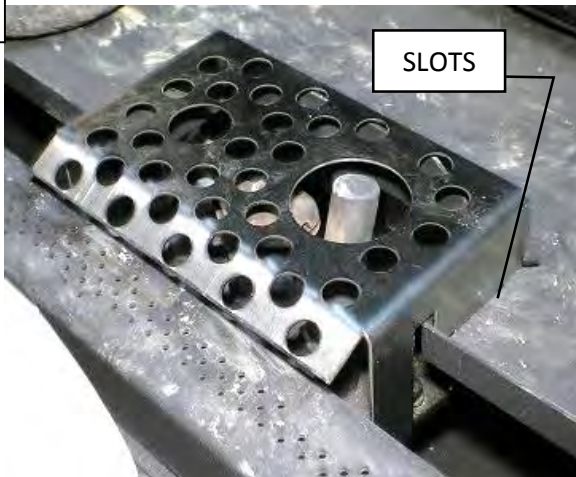

6



MQROCK1/MQRSP2 Setup for Models MQHBZDV3636/MQHBZDV4236



WARNING: Failure to position the parts in accordance with these diagrams or failure to use only parts specifically approved with this appliance may result in property damage or personal injury.

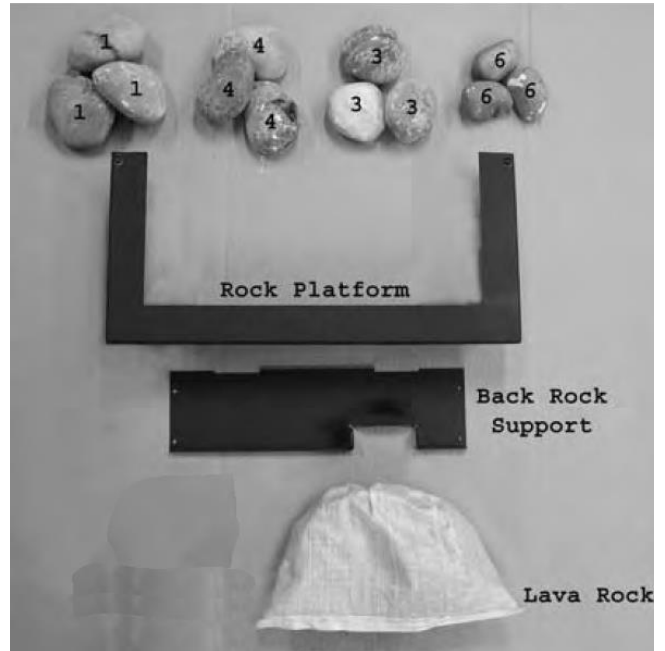

PARTS LIST

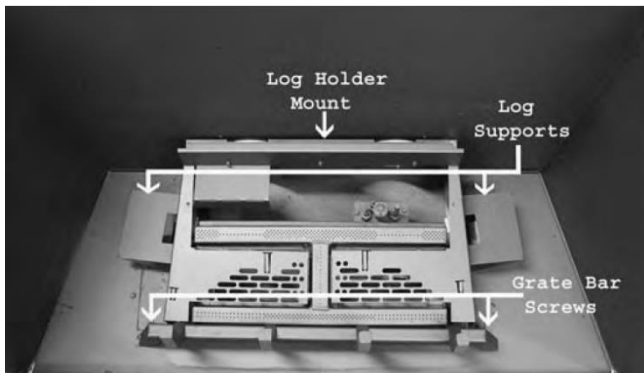

STEP 1: Remove the log holder mount, log supports, and the grate bar.

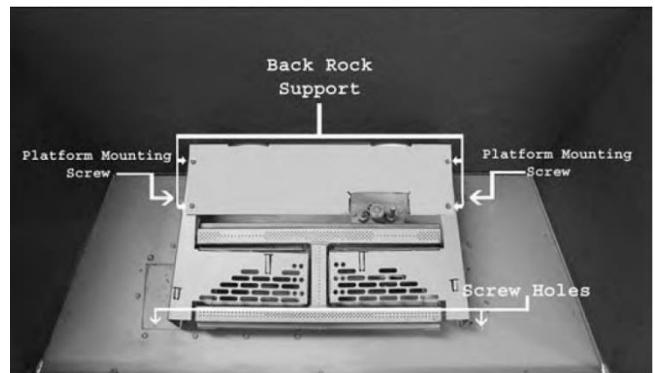

STEP 2: Attach the back rock support with the 4 screws as shown. Replace/reinstall the 2 screws from the grate bar.



STEP 3: Using the platform mount access holes, attach the rock platform as shown.



STEP 4: Fill around the rock platform with lava rock. Do not place any lava rock on the burner.

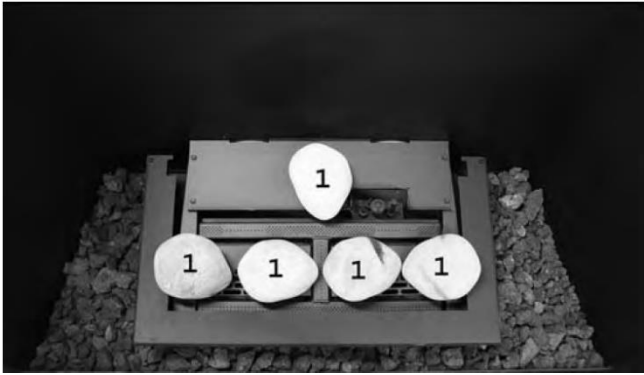

STEP 5: Place rocks #1 onto the burner as shown.



STEP 6: Place rocks #3 onto the burner as shown.



STEP 7: Place rocks #4 onto the burner as shown.



STEP 8: Place rocks #6 onto the burner as shown.



STEP 9: Place remaining rocks #4 and #6 into position as shown.



Finished Rock F2 Setup

Placement of rocks for steps 8 and 9 can be random.

Do not place any of the rocks directly over the burner tubes.

MQROCK1/MQRSP3 for HBZDV3624/28 and HBZDV4224/28



WARNING: Failure to position the parts in accordance with these diagrams or failure to use only parts specifically approved with this appliance may result in property damage or personal injury.



PARTS LIST

MQRSP3 (ROCK PLATFORM)

2 SCREWS



STEP 1: Remove the 2 grate bar screws and remove the grate bar.

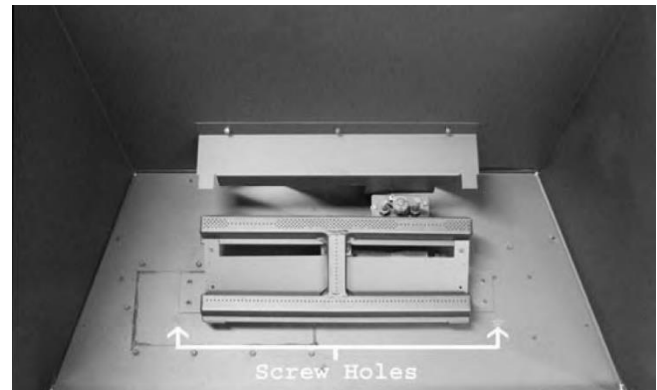

STEP 2: Replace/reinstall the 2 screws from the grate bar.



STEP 3: Using the rock platform mount holes, attach the rock platform to the burner pan as shown.



STEP 4: Fill around the rock platform with lava rock. Do not place lava rock on the burner tube.

MQROCK1/MQRSP3 for HBZDV3624/28 and HBZDV4224/28



STEP 5: Place rocks #1 onto the burner as shown. Do not place rocks directly onto the burner tubes.



STEP 6: Place rocks #3 into position as shown. Do not place rocks directly onto the burner tubes.



STEP 7: Place rocks #4 into position as shown.



STEP 8: Place rocks #6 into position as shown.



STEP 9: Place remaining rocks #3 and #4 into position as shown or at random.



Finished Rock F3 Setup

Never place any of the rocks directly onto the burner tubes.

Gas Line Installation

This gas appliance should be installed by a qualified installer in accordance with local building codes and with current CAN/CGA - B149.1 or .2 installation codes for Gas Burning appliances and equipment in Canada and the National Fuel Gas Code ANSI Z223 in the U.S.A.

1. The gas pipeline can be brought in through either the right or the left side of the appliance. A knockout is provided at either location to allow for the gas pipe installation and testing of any gas connection.
2. The gas control inlet is 3/8" NPT. Typical installation layout for rigid pipe is shown at right.
3. When using copper or flex connector, use only approved fittings. Always provide a union so that gas line can be easily disconnected for burner or fan servicing. See gas specification for pressure details and ratings.
4. When a vertical section of gas pipe is required for the installation, a condensation trap is needed. See CAN/CGA-B149.1 or .2 for code details.
5. For natural gas, a minimum of 3/8" iron pipe with gas minimum pressure of 4.5" w.c. must be used for supply from the gas meter. Consult with the local gas utility if any questions arise concerning pipe sizes.
6. A 1/8" NPT plugged tappings are accessible for test gauge connection both on the inlet and outlet of the gas valve.
7. Turn the gas supply ON and check for leaks. **DO NOT USE OPEN FLAME FOR THIS PURPOSE.** Use an approved leak testing solution.
8. The appliance and its individual shutoff valve must be disconnected from the gas supply piping system during any pressure testing of that system at test pressures in excess of 1/2 PSIG (3.5 KPa).
9. The appliance must be isolated from the gas supply piping system by closing its individual shutoff valve during any pressure testing of the gas supply piping system at test pressures equal to or less than 1/2 PSIG (3.5 KPa).

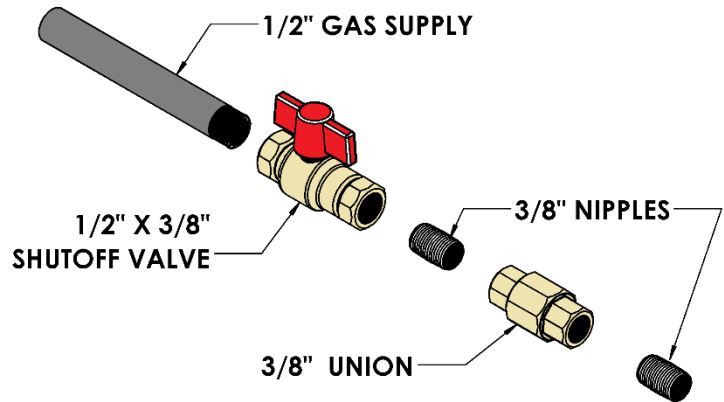

NOTE: The gas line connection may be made of 1/2" rigid pipe or an **Approved Kingsman Flex Connector, such as FP15GC.** Since some municipalities have additional local codes, it is always best to consult your local authorities and the current CAN/CGA - B149.1 or .2 installation code in Canada or the National Fuel Gas code ANSI Z223.1 in the U.S.A

For the state of Massachusetts a T-handle gas shut-off valve must be used on a gas appliance. This T-handle gas shut-off valve must be listed and approved by the state of Massachusetts. This is in reference to the state of Massachusetts state code CMR238.

Important: Always check for gas leaks with a soap and water solution. Do not use open flame for leak testing.

Shutoff valves installed in tubing systems shall be rigidly and securely supported independently of the tubing.

Gas Specifications

MODELS	HBZDV3624N NE / NE2	HBZDV3624LP LPE / LPE2	HBZDV3628N NE / NE2	HBZDV3628LP LPE / LPE2	MQHBZDV3636N NE/NE2	MQHBZDV3636LP LPE/LPE2
Fuel	Natural Gas	Propane	Natural Gas	Propane	Natural Gas	Propane
Gas Control	N - Millivolt N/NE2 - IPI	LP - Millivolt LPE/LPE2 - IPI	N - Millivolt N/NE2 - IPI	LP - Millivolt LPE/LPE2 - IPI	N - Millivolt N/NE2 - IPI	LP - Millivolt LPE/LPE2 - IPI
INPUT						
Maximum	24,000 BTU	22,000 BTU	28,000 BTU	26,000 BTU	30,500	29,200
Low	14,000 BTU	15,000 BTU	20,000 BTU	19,000 BTU	20,600	22,200
Orifice Size (0-4500ft)	# 42	# 53	# 37	# 52	#36	#51
Air Shutter	1/8"	Fully Open	7/32"	Fully Open	3/16"	5/16"
Gas Inlet Size S.I.T. 820 Nova, 3/8" NPT						
Gas Supply Pressure			Minimum	Normal	Maximum	
Natural Gas			5.5"	7"	9"	
Propane			11"	11"	12"	
Manifold Pressure			Natural Gas		Propane	
Manifold Pressure High			3.5 IN. W.C./ .87 KPa		10 IN. W.C./2.61 KPa	
Manifold Pressure Low			1.6 IN. W.C./ .40 KPa		6.3 IN. W.C./1.57 KPa	

Annual Inspection List for Determining Safe Operation of a Direct Vent Gas Fireplace

Refer to this checklist for proper maintenance, safe use, and operation.

See each section for more specific information.

1. Inspect and operate all pressure relief mechanisms (i.e., relief dampers, spring loaded door latches) installed on your appliance to verify relief mechanisms are free from obstruction to operate.

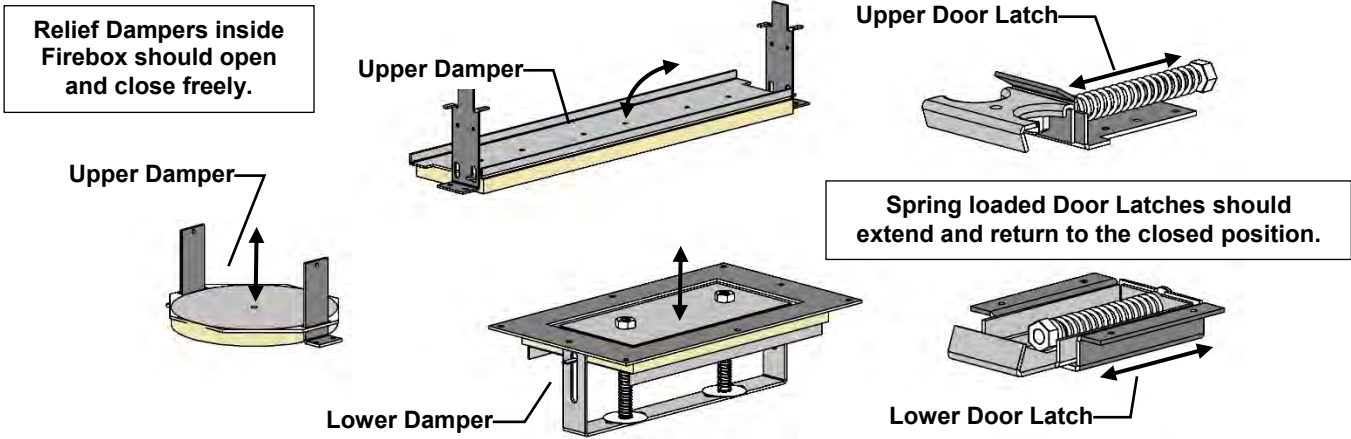

2. Clean glass window with a suitable fireplace glass cleaner. Abrasive cleaners must not be used. Be careful not to scratch the glass when cleaning.

3. Inspect the operation of the Pilot. Ensure that it is working properly.

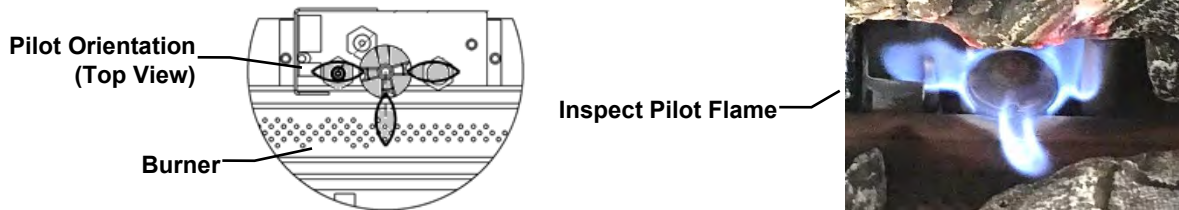

4. Inspect and ensure the lighting of the main burner occurs within 4 seconds of the main gas valve opening. (refer to **Monthly Flame Inspection**). Inspect primary air openings for blockage.

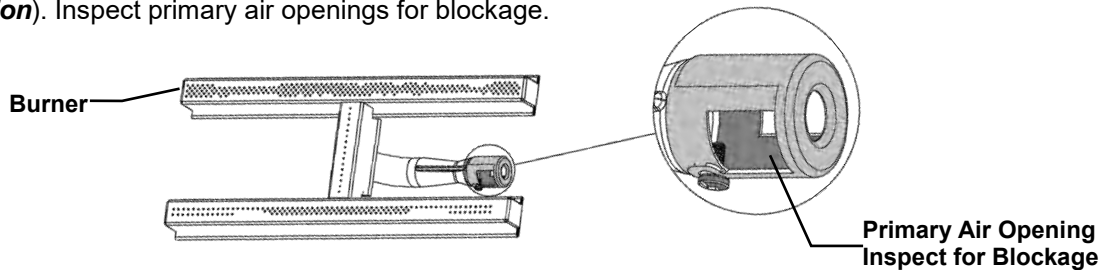

5. Inspect condition of vent and vent terminal for sooting or obstruction and correct if present.
6. Vacuum and clean any debris in the firebox that is not supposed to be there.
7. Test and measure the flame failure response time of the flame safety system. It must de-energize the safety shutoff in no more than 30 seconds.

Procedure for Millivolt Units: Turn on fireplace for 5 minutes. Shut off fireplace while listening to valve. A “click” should be heard within 30 seconds. This indicates the safety shutoff is working properly.

Procedure for IPI Units: Turn on fireplace and allow main burner to come on. Then disconnect Flame Sense wire from IPI Module (X3 Connection). The fireplace should shut down immediately.
8. Check all accessible gas-carrying tubes, connections, pipes and other components for leaks.

Troubleshooting the Gas Control System

⚠ WARNING

BEFORE DOING ANY GAS CONTROL SERVICE WORK, REMOVE THE GLASS FRONT.

NOTE: Before troubleshooting the gas control system, be sure external gas shut off is in the "On" position.

Problem	Possible Causes	Corrective Action
Spark igniter will not light.	Defective or misaligned electrode at pilot.	Check for spark at electrode and pilot: if no spark and electrode wire is properly connected, replace igniter.
	Defective igniter (push-button).	Using a match, light pilot. If pilot lights, turn off pilot and push the red button again. If pilot will not light - check gap at electrode and pilot should be 1/8" to 1/4" to have a strong spark.
Pilot will not stay lit after carefully following lighting instructions.	Defective thermocouple (flame switch where applicable).	Check pilot flame. Must impinge on generator and thermocouple. Clean and/or adjust pilot for maximum flame impingement on generator and thermocouple. Replace thermocouple if pilot will not hold. (Hand tight 1/8 turn on replacement)
	Defective valve magnet.	Replace valve, if pilot won't hold after the thermocouple is replaced.
Pilot burning, no gas to burner, valve knob "ON", and wall switch "ON".	Wall switch or wires defective.	Check wall switch and wires for proper connections. Jumper wire across terminals at wall switch. If burner comes on, replace defective wall switch. If okay, jumper wires, across wall switch wires at valve. If burner comes on, wires are faulty or connections are bad.
	Generator may not be generating sufficient voltage.	Check generator with millivolt meter. Take reading at generator terminals of gas valve. Should read 325 millivolts minimum while holding valve knob depressed in pilot position and wall switch "off" Replace faulty generator if reading is below specified minimum.
	Plugged burner orifice.	Check burner orifice for stoppage and remove.
	Defective automatic valve operator.	Remove wall switch wires from gas valve. Install jumper wires from top bottom terminals of gas valve. Turn valve on "ON". If main burner does not light, replace valve.
Frequent pilot outage problem.	Pilot flame may be too low or blowing (high) causing the pilot safety to drop out.	Clean and/or adjust pilot flame for maximum flame impingement on generator and thermocouple. *See NOTE below – Seven Day Timer
Flame lifts off burner and goes out in less than 30 seconds.	Inner 4" liner has come off flue or termination, flame is starving for oxygen.	Attach 4" liner to flue or termination using screws, silicone and clamps as stated in manual.
Flame lifts off burner on one side while the rest of the flame remains lit.	Improper installation of firebrick. Firebrick is likely leaning.	Be sure to position firebrick against firebox walls and be sure to use brick clips attached to the inner side of firebox.

***NOTE:** The pilot system for this appliance may be equipped with a **Seven Day Timer**, in which case the pilot flame will be extinguished if the main burner has not been turned ON for seven days.

This Seven Day Cycle is reset every time the main burner is cycled ON / OFF and the pilot remains lit.

If more than seven days has passed since the main burner has been cycled ON / OFF and the pilot is also out, follow the procedures described in this manual to light the pilot.

NOTE: MILLIVOLT UNITS WITH 7 DAY TIMER – When lighting pilot, the Pilot Knob must be pressed until a **BEEP** is heard. This procedure may take up to **TWO MINUTES**.

Burner System Maintenance

It is recommended to annually inspect and clean the Burner System to prevent malfunction and / or sooting. This operation should be performed by your dealer or a qualified technician.

!-CAUTION-

Before servicing the burner system ensure that the gas supply is turned OFF and disconnect all electrical connections to the appliance. Allow the appliance to cool to room temperature. Note that the pilot assembly may be hot in an intermittent or standing-pilot system—even if the main burner was never on. Exercise caution when working within the area.

-ALL WORK SHOULD BE PERFORMED BY A QUALIFIED AND CERTIFIED TECHNICIAN-

Monthly Flame Inspection: It is recommended to turn on the unit at least once a month and inspect the flame pattern to ensure there are no problems with the burner tube. The pilot flame should also be inspected monthly to ensure proper operation.

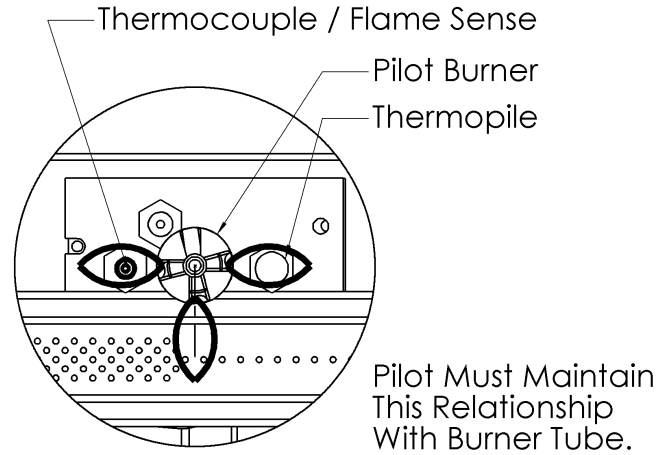
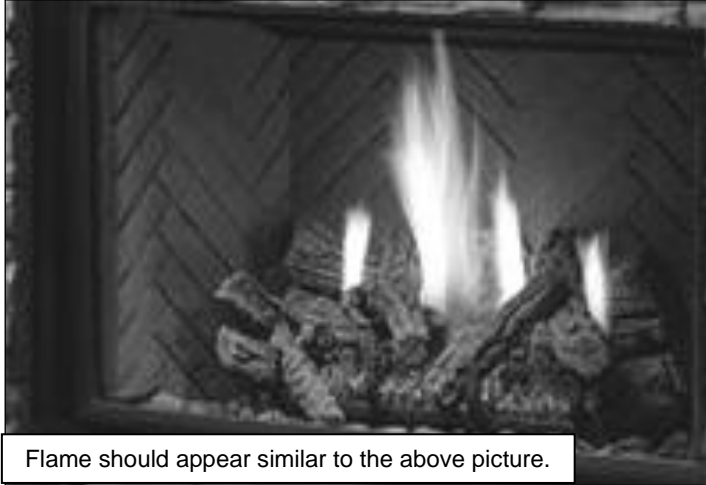

Conversion Kit Instructions – PART A

Kit Number	Description	Pilot Orifice	Burner Orifice Brass (1000-255)	Brass Nipple	Air Shutter	Hi/Lo Regulator
3624HB -CKLP 3628HB -CKLP 3636HB-CKLP	Propane Conversion -Millivolt-	1001-P167SI #30 (977.167)	#53 #52 #51	1000-253closed	Fully Open Fully Open 5/16"	1001-P202SI (0.907.202)
3624HB -CKNG 3628HB -CKNG 3636HB-CKNG	NG Conversion -Millivolt-	1001-P165SI #51 (977.165)	#42 #37 #36	1000-253closed	1/8" 7/32" 3/16"	1001-P201SI (0.907.201)
3624HB-CKLPI 3628HB-CKLPI 3636HB-CKLPI 3624HB-CKLP2 3628HB-CKLP2 3636HB-CKLP2	Propane Conversion -IPI -	1001-P168SI #35 (977.168)	#53 #52 #51 #53 #52 #51	1000-253closed	Fully Open Fully Open 5/16" Fully Open Fully Open 5/16"	1002-P014SI 1002-P014SI 1002-P014SI 1002-P012SI 1002-P012SI 1002-P012SI
3624HB -CKNGI 3628HB -CKNGI 3636HB-CKNGI 3624HB-CKNG2 3628HB-CKNG2 3636HB-CKNG2	NG Conversion - IPI -	1001-P166SI #62 (977.166)	#42 #37 #36 #42 #37 #36	1000-253closed	1/8" 7/32" 3/16" 1/8" 7/32" 3/16"	1002-P016SI 1002-P016SI 1002-P016SI 1002-P013SI 1002-P013SI 1002-P013SI

- Refer to **Gas Specifications Chart** for inlet pressures and input ratings.
- Clock meter to verify input rate.
- Place conversion label as close to converted gas control as possible.

- Refer to **lighting instructions** to verify the normal operating sequence of the ignition system.
- Refer to **Burner System Maintenance** for proper relationship of the pilot flame to the main burner and for main burner flame appearance.

Conversion Kit Instructions – PART A

⚠ Caution: The gas supply shall be shut off prior to disconnecting the electrical power, before proceeding with the conversion.

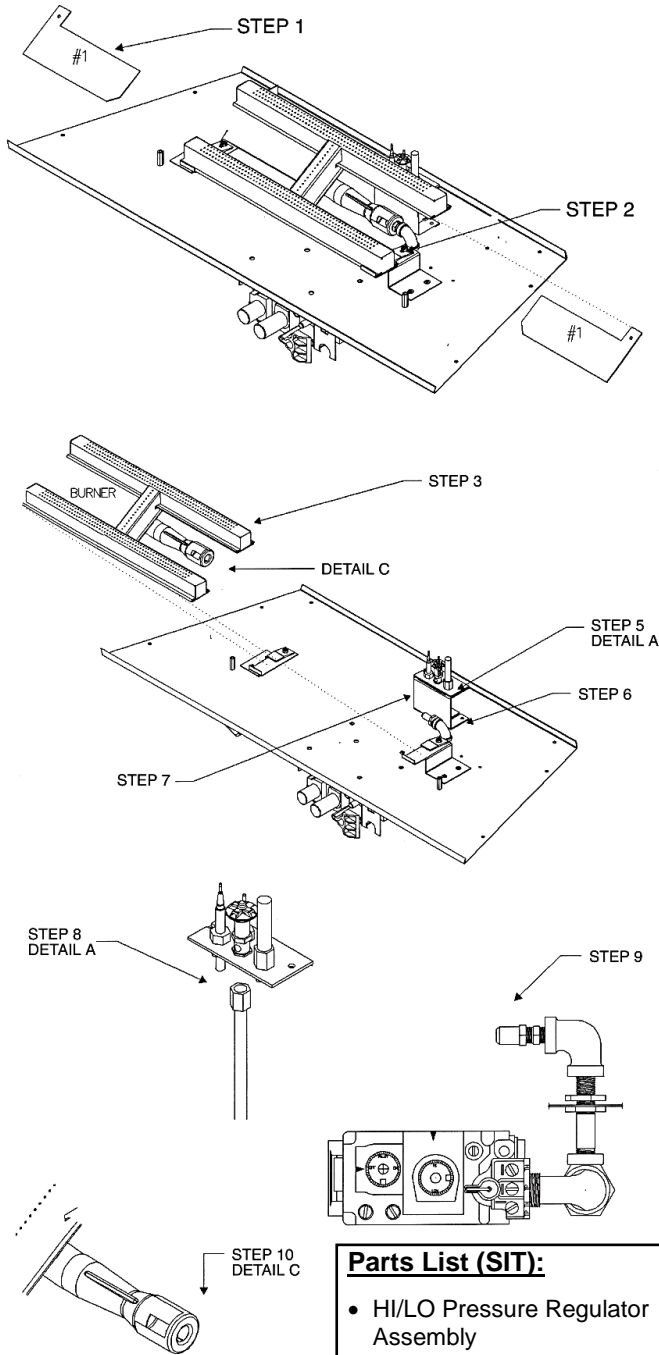

Parts List (SIT):

- HI/LO Pressure Regulator Assembly
- Burner Orifice
- Brass Nipple
- Instructions
- Conversion Kit Label
- Pilot Orifice

PLEASE CONFIRM THAT STEP 4 IS UNDERSTOOD BEFORE PROCEEDING WITH CONVERSION.

⚠ WARNING: This conversion kit shall be installed by a qualified service agency in accordance with the manufacturer's instructions and all applicable codes and requirements of the authority having jurisdiction. If the information in these instructions is not followed exactly, a fire, explosion or production of carbon monoxide may result causing property damage, personal injury or loss of life. The qualified service agency is responsible for the proper installation of this kit. The installation is not proper and complete until the operation of the converted appliance is checked as specified in the manufacturer's instructions supplied with the kit.

1. Remove the 2 ember plates from the burner. This step may not be required, depending on the type of burner assembly.
2. Loosen the 2 screws holding the burner in place.
3. Slide the burner to the left to expose the orifice.
4. **Before going any further you need to verify which pilot system is in use. If there is a spring clip below the pilot hood then proceed to STEP 5 in PART B.**
5. Remove the 2 screws that hold the pilot to the bracket.
6. Remove the 2 screws that attach the pilot bracket to the firebox bottom.
7. Remove the pilot bracket to expose the pilot assembly.
8. Remove the pilot tube and nut from the pilot assembly using a 10mm wrench; slide the tube and nut down. You may have to tap the pilot hood lightly to release the pilot orifice. Place new pilot orifice into the pilot assembly and reinstall the pilot tube and nut. Tighten with wrench. Reinstall pilot bracket at this time.
9. Remove main orifice using a 1/2" wrench and replace with new conversion orifice.
10. Adjust the primary air setting to the correct setting as specified in the manual or label plate. To adjust the air setting, loosen the screw on the side of the tube and rotate to the correct opening using a drill bit or tape measure. Retighten screw. Reinstall burner at this time reversing STEPS 3, 2 and 1.
11. Follow instructions supplied with the conversion HI/LO to convert the valve from one type of fuel to the other.
12. Check for gas leaks around the pilot burner tube and face of valve.
13. Attach conversion label to label plate on bottom of unit, writing information as needed.

IMPORTANT: Always check for gas leaks with a soap and water solution. DO NOT USE OPEN FLAME FOR LEAK TESTING.



Instructions for converting SIT 190 series pilot burner injector from NG to PROPANE and from PROPANE to NG only. This information should be considered as supplemental to the Appliance Manufacturer's Instructions.

WARNING! The installation of this conversion kit must only be undertaken by a qualified and certified gas appliance installer.

1. Shut-off the gas supply to the appliance.
2. Allow the pilot burner to cool to room temperature.

WARNING: Touching a hot pilot burner can result in injury.

3. The pilot hood is held in place by spring. First remove the spring, then remove the hood by pulling it up from the pilot bracket (fig. 1).
4. Insert a 5/32" or 4 mm Allen wrench into the hexagonal key-way of the injector (fig. 2), and rotate it counter-clockwise until it is free of the injector journal.
5. Verify that the new injector is proper for the application. The injector size is stamped on the side of the injector near the top. Propane injectors have a groove machined around their circumference near the top, while NG injectors do not have a groove (fig. 4). Refer to the Appliance Manufacturer's instruction sheet for the proper injector size.
6. Insert the Allen wrench into the end of the injector. Then, insert the injector into injector journal, and rotate the injector clockwise until a torque of 9 lbf in (1.0 Nm) is achieved.
7. First replace the pilot hood by aligning the tab on the base of the hood with the slot in the side of the pilot journal, and push the hood down, onto the pilot bracket (fig. 3). The hood must sit squarely on the bracket for proper operation. Then replace the spring by pushing it on his seat (fig.3). Check to insure that the hood is properly seated onto the pilot bracket and that the spring is properly inserted onto his seat.
8. Restore the gas supply to the appliance, and ignite the pilot burner. Verify proper ignition and operation.

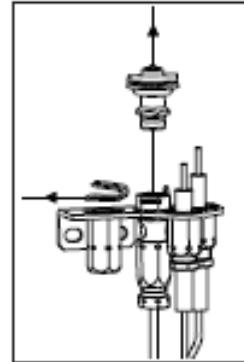

fig. 1

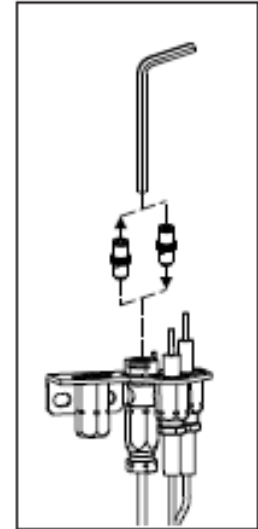

fig. 2

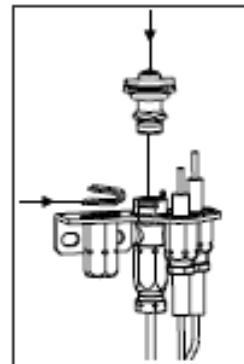

fig. 3

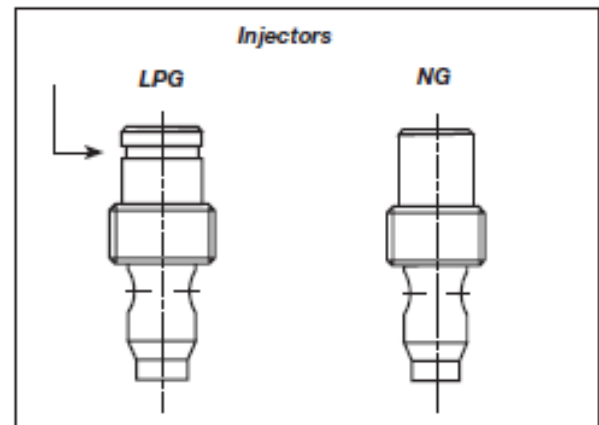

fig. 4

WARNING!

This conversion kit must **ONLY** be applied as part of a conversion kit supplied by the **APPLIANCE MANUFACTURER** for the specific appliance, and type of gas, being converted.



SIT GROUP

www.sitgroup.it

installation instructions

7 252 136

820 NOVA mV

Modulating Conversion Kit



-WARNING!

The installation of this conversion kit must only be undertaken by a qualified and certified gas appliance installer.

MODULATING PRESSURE REGULATOR CONVERSION KIT INSTALLATION OR REPLACEMENT INSTRUCTIONS.

- 1 Turn control knob to the OFF position, and shut off the gas supply to the valve.
- 2 Using a Torx T20, or slotted screwdriver, remove and discard the three pressure regulator mounting screws (A), pressure regulator tower (B), and the spring and diaphragm assembly (C). (If applicable)
- 3 Insure that the rubber gasket (D) is properly positioned and install the new modulating pressure regulator assembly to the valve using the new screws (E) supplied with the kit. Tighten screws securely. (Reference torque = 25 In.Lb.)
- 4 Install the enclosed identification label (F) to the valve body where it can be easily seen.
- 5 Apply gas to system and re-light appliance according to manufacturers instructions.
- 6 With the main burner "ON", test the new pressure regulator assembly for leaks using a soap solution.
- 7 Relight the main burner in both the HI and LO positions, and verify proper burner ignition and operation.

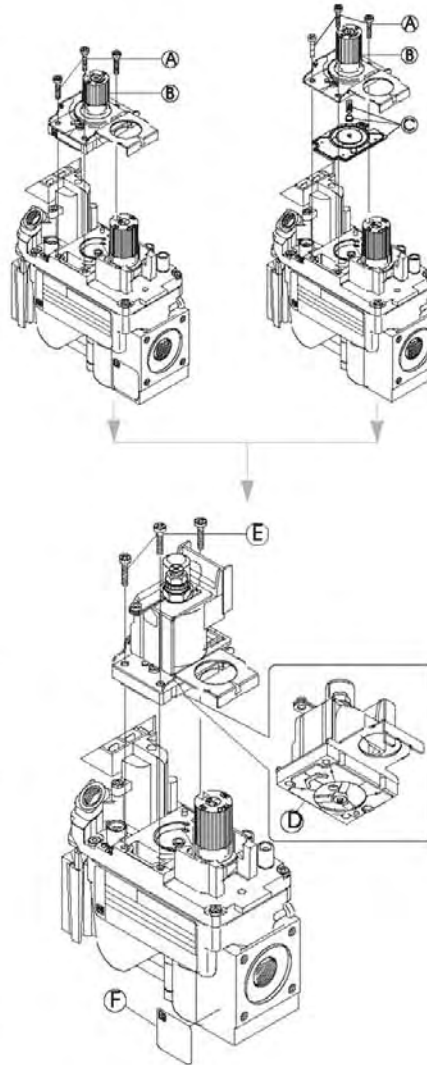

-WARNING!

This modulating conversion kit must ONLY be applied as part of a conversion kit supplied by the APPLIANCE MANUFACTURER for the specific appliance, and type of gas, being converted.

INSTALLER NOTICE. These instructions must be left with appliance.



SIT Group

Removing Burner System / Burner Access Cover



Warning: Failure to position the parts in accordance with these diagrams or failure to use only parts specifically approved with this appliance may result in property damage or personal injury.



Warning: Before starting removal of parts turn off gas supply, disconnect 110 volts to fan system and disconnect 110 volts to electronic ignition burner system if applicable.



Warning: All work should be performed by a qualified and certified technician.

If Fireplace has been installed with optional CVCK (Clean View Circulating Kit) to service fan system or burner system controls, the burner access cover and burner system will have to be removed.

Burner access cover removal

1. Remove door, logs, brick panels, false bottom, burner grate and burner from firebox.
2. Burner grate is fastened by 2 screws. Remove screws and take out grate.
3. Remove ember plates right and left of burner. Ember plates are held in place by 2 screws each.
4. Loosen screws from burner retainer tabs and slide burner to the left to remove from orifice.
5. Remove rear log holder by removing the 2 screws on each side of log holder.
6. **HB3636 ONLY-** Remove left and right-side log supports and ember plate supports by removing the 2 screws from side of support.
7. Remove 10 screws holding burner access cover in place. Push down on one corner of access cover to break seal of cover. Once loose, cover can be slid under firebox bottom to expose gas connection.

Removing Burner System

1. Disconnect gas line connection at burner system through access cover opening.
2. Remove extension knobs and wiring from face of gas valve.
3. Remove screws from perimeter of burner system pan, lift pan at one back corner and rotate pan up from back of firebox. Make sure when tilting up and removing burner system that all fan and valve control wiring is disconnected at this time.
4. Before re-installing burner access cover / burner system, remove old Mil Pac sealant and apply new sealant.

CAUTION: High temperature sealant has been applied to burner access cover and burner system pan. New sealant will have to be applied when re-installing access cover and burner system to maintain the integrity of sealed combustion chamber. Mil Pac part #840099 or Kingsman part #1000-150MP sealant can be purchased from your Kingsman retailer or distributor.

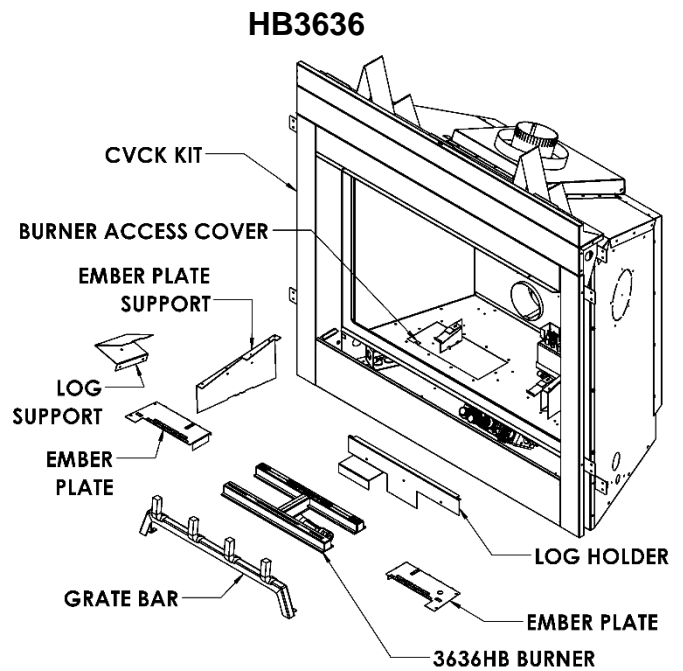
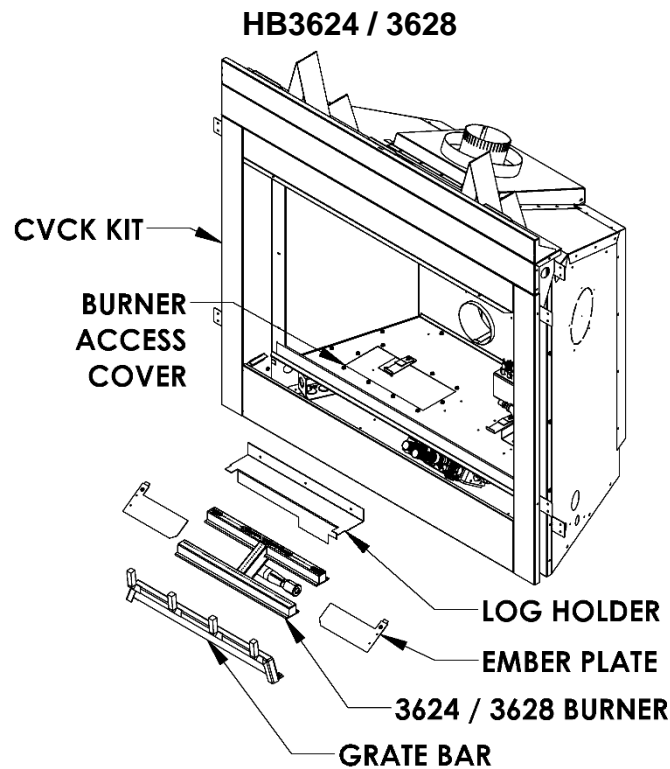

Millivolt System, Lighting, and Burner Control

FOR YOUR SAFETY READ BEFORE LIGHTING

WARNING: If you do not follow these instructions exactly, a fire or explosion may result causing property damage, personal injury or loss of life.

BEFORE LIGHTING

- | | |
|--|--|
| <p>A This appliance has a pilot which must be lighted by hand. When lighting the pilot, follow these instructions exactly.</p> <p>B Smell all around the appliance area for gas. Be sure to smell next to the floor because some gas is heavier than air and will settle on the floor.</p> <p>WHAT TO DO IF YOU SMELL GAS</p> <ul style="list-style-type: none"> Do not try to light an appliance. Do not touch any electrical switch; do not use any phone in your building. | <ul style="list-style-type: none"> Immediately call your gas supplier from a neighbour's phone. Follow the gas supplier's instructions. If you cannot reach your gas supplier, call the fire department. <p>C Use only your hand to push or turn the gas control knob. Never use tools. If the knob will not push in or turn by hand, don't try to repair it. Call a qualified technician. Force or attempted repair may result in a fire or explosion.</p> <p>D Do not use the appliance if any part has been under water. Immediately call a qualified service technician to inspect the appliance and to replace any part of the control system which has been under water.</p> |
|--|--|

LIGHTING INSTRUCTIONS

- | | |
|--|---|
| <ol style="list-style-type: none"> Stop! Read the safety information above this label. Set the thermostat to lowest setting. Turn off all electrical power to the appliance. Locate valve under the burner assembly. If the control knob is not already in the off position, i.e. the word "OFF" in the 9 o'clock position, then push in the gas control knob slightly and turn ⤵ clockwise to "OFF". NOTE: Knob cannot be turned from "PILOT" to "OFF" unless knob is pushed in slightly. Do not use force. Wait five [5] minutes to clear out any gas. If you then smell gas. STOP! Follow "B" in the safety information above on this label. If you don't smell gas then go to the next step. Now push in the control knob slightly and turn ⤵ counter-clockwise to the "PILOT" position. Push in the control knob all the way and hold it. With the other hand push in the red igniter button until you hear a click. Now observe closely the pilot burner located on the rear center-left hand side of the main burner. | <p>If a flame has appeared then continue to depress the control knob for 20 seconds. If the flame did not appear then continue to depress the red igniter button every 5 seconds until a flame is established. NOTE: If after 30 seconds a flame has not yet been established then turn the control knob back to the off position and repeat steps 5, 6 & 7.</p> <ol style="list-style-type: none"> Once the pilot has been established hold the control knob in the depressed position for approximately 25 seconds before releasing. If the flame goes out then repeat steps 7 and 8. <ul style="list-style-type: none"> If the knob does not pop up when released, stop and immediately call your service technician or gas supplier. If the pilot will not stay lit after several tries, turn the gas control to "OFF" and call your service technician. Now turn the control knob to the "ON" position. The burner will not light unless the wall switch thermostat or remote control is turned "ON" or in the case of the thermostat there is a call for heat. Close the access door and turn all electrical power back to the appliance. |
|--|---|

TO TURN OFF THE APPLIANCE

- | | |
|---|--|
| <ol style="list-style-type: none"> Set the thermostat to lowest setting. Turn off all electric power to the appliance if service is to be performed. Open the control access door. | <ol style="list-style-type: none"> Push in the gas control knob slightly and turn ⤵ clockwise to the "OFF" position. Do not force. Replace control access panel. |
|---|--|

NOTE: Only one on/off device (manual on/off, remote control, or hard wired thermostat) should be connected to the appliance at any one time, this is most important when installing an insert or stove as the on/off rocker switch is installed at the factory.

Recommended Maximum Lead Length (Double Wire)
When Using Wall Switch or Thermostat

Wire Size	Max. Length
14ga	100ft [30.4m]
16ga	64ft [19.5m]
18ga	40ft [12.1m]
20ga	25ft [7.6m]
22ga	15ft [4.5m]

CAUTION: DO NOT WIRE 120V POWER TO MILLIVOLT SWITCHES OR THERMOSTAT.

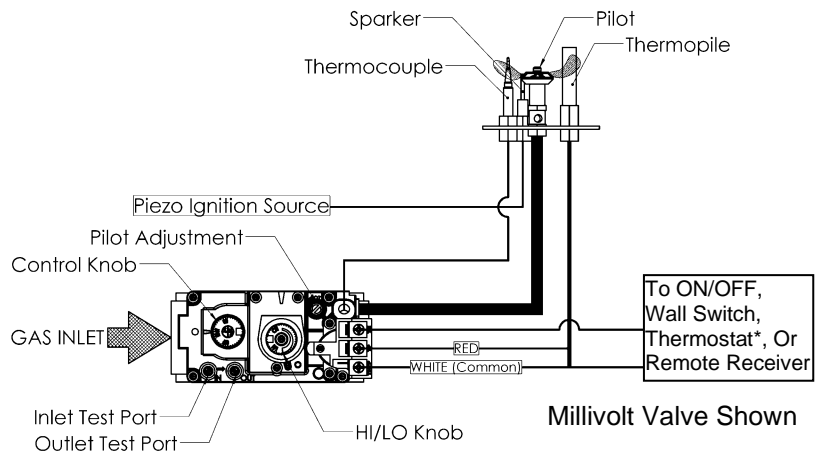

- Lighting Instructions for Millivolt Valve with 7 Day Timer -

FOR YOUR SAFETY READ BEFORE LIGHTING

WARNING: If you do not follow these instructions exactly, a fire or explosion may result causing property damage, personal injury or loss of life.

- A. This appliance has a pilot which must be lighted by hand. When lighting the pilot, follow these instructions exactly.
- B. **BEFORE OPERATING** smell around the appliance area for gas. Be sure to smell next to the floor because some gas is heavier than air and will settle on the floor.
- WHAT TO DO IF YOU SMELL GAS
- Do not try to light any appliance.
 - Do not touch any electric switch; do not use any phone in your building.
 - Leave the building immediately.
 - Immediately call your gas supplier from a neighbor's phone. Follow the gas supplier's instructions.
 - If you cannot reach your gas supplier, call the fire department.
- C. Do not use this appliance if any part has been under water. Immediately call a qualified service technician to inspect the appliance and replace any part of the control system and any gas control which has been under water.
- D. Use only your hand to push in or turn the gas control knob. Never use tools. If the knob will not push in or turn by hand, do not try to repair it; call a qualified service technician. Force or attempted repair may result in a fire or explosion.

OPERATING INSTRUCTIONS

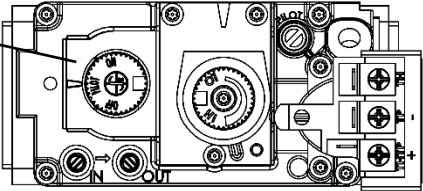
1. **Stop!** Read the safety information above on this label.
 2. This appliance is equipped with an on-demand pilot that shuts off after 7 days.
 3. Set the thermostat to lowest setting.
 4. Turn off all electric power to the appliance.
 5. Locate valve under the burner assembly.
 6. If the control knob is not already in the off position, i.e. the word "OFF" in the 9 o'clock position, then push in the gas control knob slightly and turn ⤵ clockwise to "OFF". NOTE: Knob cannot be turned from "PILOT" to "OFF" unless knob is pushed in slightly. Do not use force.
- Gas Control knob shown in "PILOT" position
- 
7. Wait five (5) minutes to clear out any gas. Then smell for gas, including near the floor. If you smell gas, STOP! Follow "B" in the safety information above this label. If you do not smell gas, go to next step.
 8. Now push in the control knob slightly and turn ⤴ counter-clockwise to the "PILOT" position.
 9. Push in the control knob all the way and hold it. With the other hand push in the red igniter button until you hear a click. Now observe closely the pilot burner located on the rear center-left hand side of the main burner. If a flame has appeared then continue to depress the control knob until a BEEP is heard. This procedure may take up to TWO MINUTES.
 10. If the pilot flame did not appear then continue to depress the red igniter button every 5 seconds until a flame is established. NOTE: If after 30 seconds a flame has not yet been established then turn the control knob back to the off position and repeat steps 7, 8, and 9.
 11. Once the pilot has been established hold the control knob in the depressed position for approximately 25 seconds before releasing. If the flame goes out then repeat steps 9 and 10.
 - If the knob does not pop up when released, stop and immediately call your service technician or gas supplier.
 - If the pilot will not stay lit after several tries, turn the gas control to "OFF" and call your service technician.
 12. Now turn the control knob to the "ON" position. The burner will not light unless the wall switch thermostat or remote control is turned "ON" or in the case of the thermostat there is a call for heat.
 13. Close the access door.
 14. Turn on all electric power to the appliance.
 15. Set thermostat to desired setting.
 16. If the appliance will not operate, follow the instructions "To Turn Off Gas To Appliance" and call your service technician or gas supplier.

TO TURN OFF GAS TO APPLIANCE

1. Set thermostat to lowest setting.
2. Turn off all electric power to the fireplace if service is to be performed.
3. Open the control access door.
4. Push in the gas control knob slightly and turn ⤵ clockwise to the "OFF" position. Do not force.
5. Close the control access door.

- IPI LIGHTING INSTRUCTIONS - FOR YOUR SAFETY READ BEFORE LIGHTING

WARNING: If you do not follow these instructions exactly, a fire or explosion may result causing property damage, personal injury or loss of life.

- A. This appliance is equipped with an ignition device which automatically lights the pilot. Do not try to light the pilot by hand.
- B. **BEFORE OPERATING** smell around the appliance area for gas. Be sure to smell next to the floor because some gas is heavier than air and will settle on the floor.
- WHAT TO DO IF YOU SMELL GAS
- Do not try to light any appliance.
 - Do not touch any electric switch; do not use any phone in your building.
 - Immediately call your gas supplier from a neighbor's phone. Follow the gas supplier's instructions.
- If you cannot reach your gas supplier, call the fire department.
 - C. Do not use this appliance if any part has been under water. Immediately call a qualified service technician to inspect the appliance and replace any part of the control system and any gas control which has been under water.
 - D. If the gas valve requires repair, call a qualified service technician. Force or attempted repair may result in a fire or explosion.

OPERATING INSTRUCTIONS

1. Stop! Read the safety information above on this label.
2. Read the owner's manual including the section on "Remote Control" operation if applicable.
3. Turn off all electric power to the appliance.
4. This appliance is equipped with an ignition device which automatically lights the pilot. Do not try to light the pilot by hand.
5. Wait five (5) minutes to clear out any gas. Then smell for gas, including near the floor. If you smell gas, STOP! Follow "B" in the safety information above this label. If you do not smell gas, go to next step.
6. Turn on all electric power to the fireplace.
7. Turn "On" Switch that operates the Main Burner. For **Remote Control** units, press the ON/OFF key on the remote control. "ON" will be displayed on the LCD display and a "beep" will be heard at the unit to indicate the command has been received.
8. If the appliance will not operate, follow the instructions "To Turn Off Gas To Appliance" and call your service technician or gas supplier.

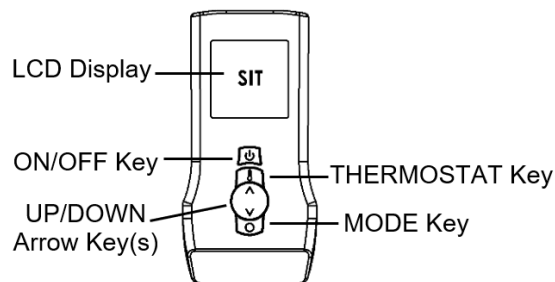

TO TURN OFF GAS TO APPLIANCE

1. Set thermostat to lowest setting. For **Remote Control** units, press the ON/OFF key on the remote control. "OFF" will be displayed on the LCD display and a "beep" will be heard at the unit to indicate the command has been received.
2. Turn off all electric power to the fireplace if service is to be performed.

IPI Electronic Ignition System

Overview

The IPI system is an advanced burner controller that provides you with the option of having either a Standing-Pilot, or an intermittent igniting system. This alternating mode is controlled by the CPI/IPI Switch (Continuous Pilot Ignition/Intermittent Pilot Ignition) located on the IPI System Box. The difference between a Standing-Pilot and an Intermittent-Pilot is in whether the pilot stays lit or shuts off:

In Standing-Pilot, the pilot assembly is lit by the IPI Main Module and continues to stay lit until 1) the CPI/IPI Switch is switched to the IPI position; 2) a loss of electrical power (battery and AC source), 3) the flame sensor loses its signal, 4) the fuel supply discontinues, or 5) the IPI Main Module malfunctions.

In the Intermittent-Pilot mode, the pilot shuts off when the appliance is not in use. The advantage of this mode is that fuel is not consumed when the fireplace is not operating.

NOTE: In some jurisdictions Intermittent-Pilot is required. That means the pilot cannot remain lit when the appliance is not operating.

Components

The core of the IPI system is the Main Module and the IPI Valve. With these two components the system is able to operate a gas fireplace. There are also other components available to complement the IPI system.

IPI System Cover: Is essential in keeping the components at their proper operating temperatures. **DO NOT OPERATE THE APPLIANCE WITHOUT THIS COVER.**

Modulating Servo Motor: Is an add-on valve component that permits HI/LO functionality to be controlled by the remote. Contrary to this feature is a Manual HI/LO Control Knob. The Modulating Servo Motor requires the Remote system to be present.

Backup Battery Pack: This component permits the IPI system to operate without the need for an external AC Adapter power source. The advantage to using the battery backup is that in the case of a power failure, the appliance is still operable.

NOTE: In certain instances the IPI Main Module requires resetting. This can occur if the system is unable to ignite the pilot or the main burner in the allotted time period. The IPI is programmed to lockout all commands. To reset this lockout you must deplete the system of all electrical power. This means to remove the batteries from the Battery Pack, remove the batteries from the Remote Receiver (if applicable), and disconnect the AC Adapter from the system. Leave the power off for approximately 25 seconds to clear its lockout.

Remote Receiver: This component provides the capability of controlling the appliance with a wireless remote transmitter.

Standing Pilot Mode for Colder Climates (Below Freezing)

For IPI models it may be necessary to set the appliance to Standing Pilot mode to maintain heat in the cavity. The purpose of this procedure is to prevent cold air from penetrating the chimney and then onto the living space. Therefore, when the internal temperature is slightly elevated the fireplace is able to freely exhaust its combustion and hence making it easier to startup.

Standing Pilot Mode for Colder Climates (Below Freezing)

For IPI models it may be necessary to set the appliance to Standing Pilot mode to maintain heat in the cavity. The purpose of this procedure is to prevent cold air from penetrating the chimney and then onto the living space. Therefore, when the internal temperature is slightly elevated the fireplace is able to freely exhaust its combustion and hence making it easier to startup.

NOTE: The pilot system for this appliance may be equipped with a Seven Day Timer, in which case the pilot flame will be extinguished if the main burner has not been turned ON for seven days. This Seven Day Cycle is reset every time the main burner is cycled ON / OFF and the pilot remains lit. If more than seven days has passed since the main burner has been cycled ON / OFF and the pilot is also out, follow the procedures described in this manual to light the pilot.

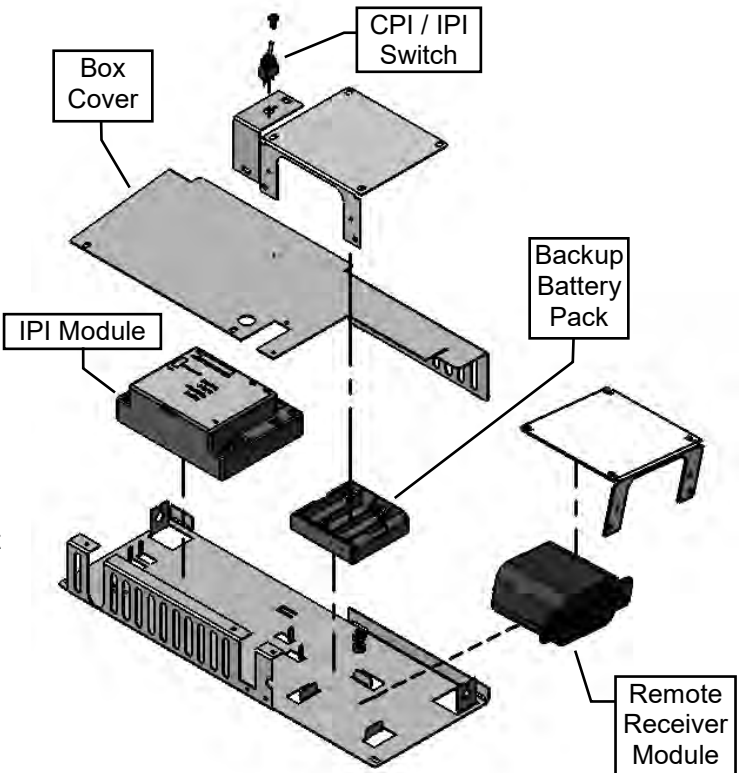

Proflame 1 -Remote Control Operation-

The Proflame GTM is configured to control the on/off main burner operation, its flame levels, and provides on/off and Smart *thermostatic control of the appliance.

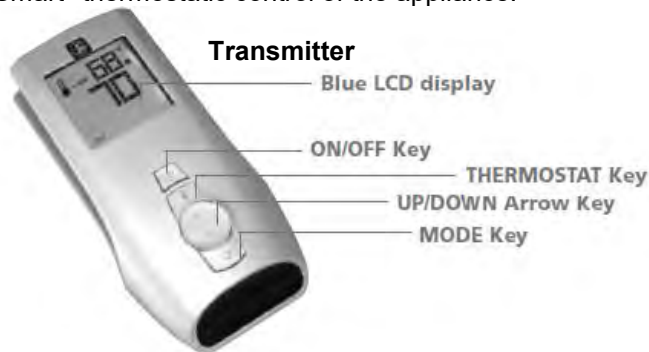

Transmitter

The Transmitter is powered by 3 AAA type batteries. A Mode Key is provided to Index between the features and a *thermostat Key is used to turn on/off or index through *thermostat functions

Remote Receiver

The Receiver connects directly to the gas valve and stepper motor with a wiring harness. The Receiver is powered by 4 AA type batteries. The Receiver three position slider switch can be set to one of three positions: ON (Manual Override), Remote (Remote control) or Off.

Initializing the System for the first time

Install 4 AA batteries into the receiver battery bay. Install 3 AAA type batteries in the Transmitter battery bay. Place the 3 position slider switch in the "Remote" position. Insert the end of a paper clip into the hole marked "PRG" on the Receiver front cover. The Receiver will "beep" three (3) times to indicate that it is ready to synchronize with a Transmitter. Push the On button. The Receiver will "beep" four times to indicate the Transmitter's command is accepted. The system is now initialized.

Temperature indication Display

With the system in the "OFF" position, press the *thermostat Key and the Mode Key at the same time. Look at the LCD screen on the Transmitter to verify that a C or F is visible to the right of the Room Temperature display.

Turn the Appliance On or Off

Press the ON/OFF Key on the Transmitter

Remote Flame Control

The Proflame GTM has six (6) flame levels. Pressing the Down Arrow Key once will reduce the flame height by one step until the flame is turned off. The Up Arrow Key will increase the flame height each time it is pressed. If the Up Arrow Key is pressed while the system is on but the flame is off, the flame will come on in the high position.

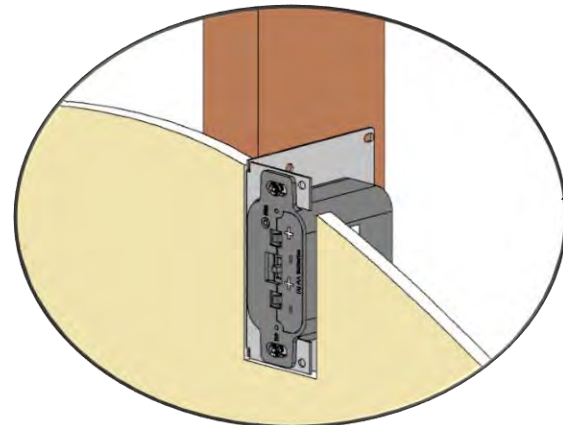

Room *thermostat (Transmitter Operation)

The Remote Control can operate as a room *thermostat. To activate this function, press the *thermostat Key. The LCD display on the Transmitter will change to show that the room *thermostat is "ON" and the set temperature is now displayed. To adjust the set temperature, press the Up or Down Arrow Keys until the desired set temperature is displayed on the LCD screen of the Transmitter.

Smart *thermostat (Transmitter Operation)

The Smart *thermostat function adjusts the flame height in accordance to the difference between the set point temperature and the actual room temperatures. As the room temperature gets closer to the set point the Smart Function will modulate the flame down. To activate this function, press the *thermostat Key until the word "SMART" appears to the right of the temperature bulb graphic. To adjust the set temperature, press the Up or Down arrow Keys until the desired set point temperature is displayed.

Key Lock Function

This function will lock the keys to avoid unsupervised operation. To activate this function, press the MODE and the UP Arrow Key at the same time. To de-activate this function, press the MODE and the UP Arrow Key at the same time.

Low Battery Detection

Transmitter - When the Transmitter batteries are low, a Battery Icon will appear on the LCD display of the Transmitter.
Receiver - When the Receiver batteries are low, No "beep" will be emitted from the Receiver when it receives an On/Off command from the Transmitter. When the batteries are replaced the "beep" will be emitted from the Receiver when the ON/OFF Key is pressed (See Initializing the System for the first time).

Manual Bypass Of The Remote System

If the batteries of the Receiver or Transmitter are low or depleted, the appliance can be turned on manually by sliding the three position slider switch on the Receiver to the ON position. This will bypass the remote control feature and the appliance main burner will come on if the gas valve is in the "On" position.

Wall Mount Option

10ft. Extension Harness (Part No. 1001-P904SI) required.

- The Remote Receiver can be mounted on a vertical wall stud using the DCHS as a mounting bracket.
- Ensure that the face is protruding 1/2" so that the face plate will be flush on the face of the wall.
- Drywall cutout size is 2" wide by 4-1/8" tall.
- Must be installed within 10ft of valve assembly (6ft recommended).

PART NO.	DESCRIPTION
1. 1006-P002SI	Valve IPI Hi/Lo NG
2. 1006-P003SI	Valve IPI Hi/Lo LP
3. 1002-P302SI	IPI Ignition Board
4. 1002-P047SI	Pilot Assembly-LP -24" Wire
5. 1002-P033SI	Pilot Assembly-NG -24" Wire
6. 1002-P850SI	AC Wall Adapter
7. 1002-P12BH	Battery Pack
8. 1001-P280SI	TC - Tubing W/Fittings 1/8 2.182.280
9. 1001-P166SI	TC - Orifice Pilot NG 977.166 #62 (IPI)
10. 1001-P168SI	TC - Orifice Pilot LP 977.168 #35 (IPI)

11. 1002-P012SI	IPI Stepper Kit - LP 907.012
12. 1002-P013SI	IPI Stepper Kit - NG 907.013
13. 1002-P014SI	IPI Reg Kit - LP Hi-Lo 907.014
14. 1002-P016SI	IPI Reg Kit - NG Hi-Lo 907.016
15. 1002-P017SI	TC - Electrode Cable & Sparker IPI 915.017 24"
16. 1002-P119SI	TC - Electrode Cable & Sparker IPI 35" (Infinite, ZCVRB47, VRB46)
17. 1002-P903SI	TC - Electrode Flame Sense IPI 007.253/915.903 24"
18. 1002-P910SI	TC - Electrode Flame Sense 35" (Infinite, ZCVRB47, VRB46)



Proflame Transmitter
1001-P023SI

NOTE: Fan and / or Light Options are not available on some fireplaces.
Check with your dealer.

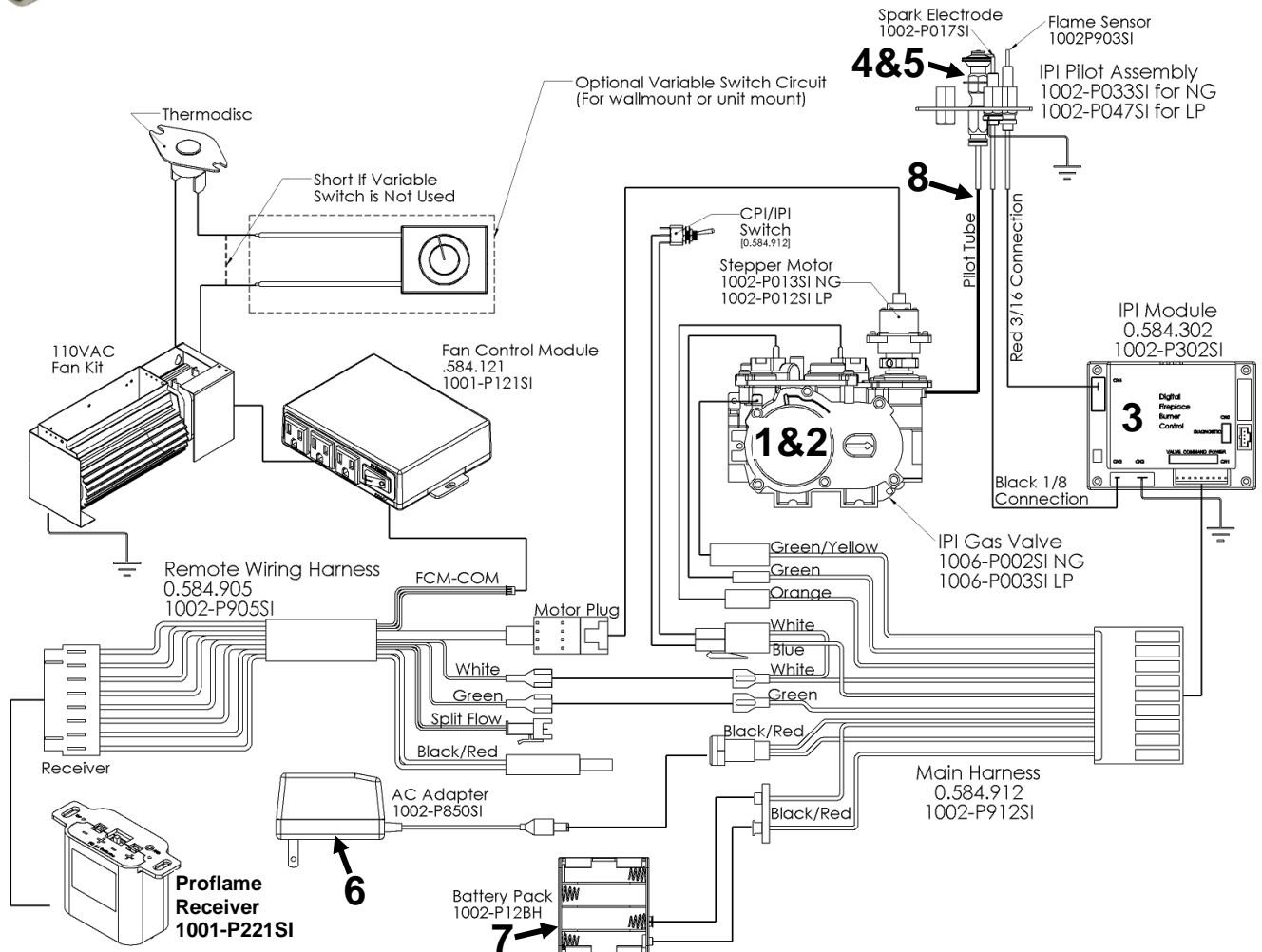

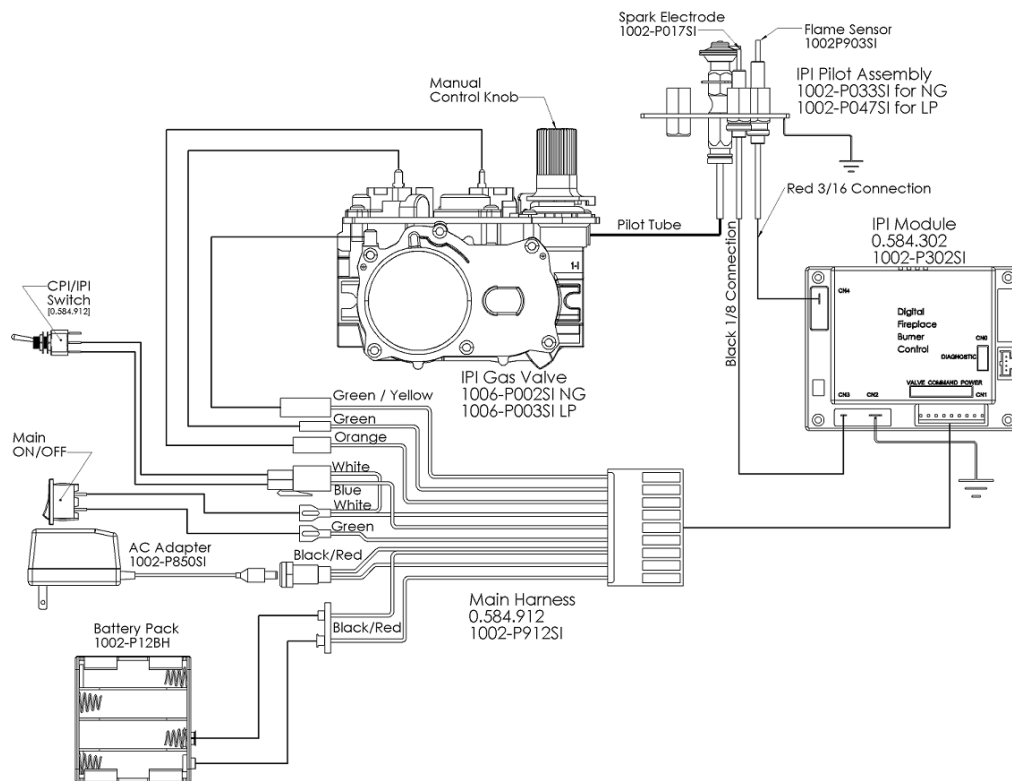

Configuration #1: Basic manual HI/LO and manual ON/OFF capabilities.

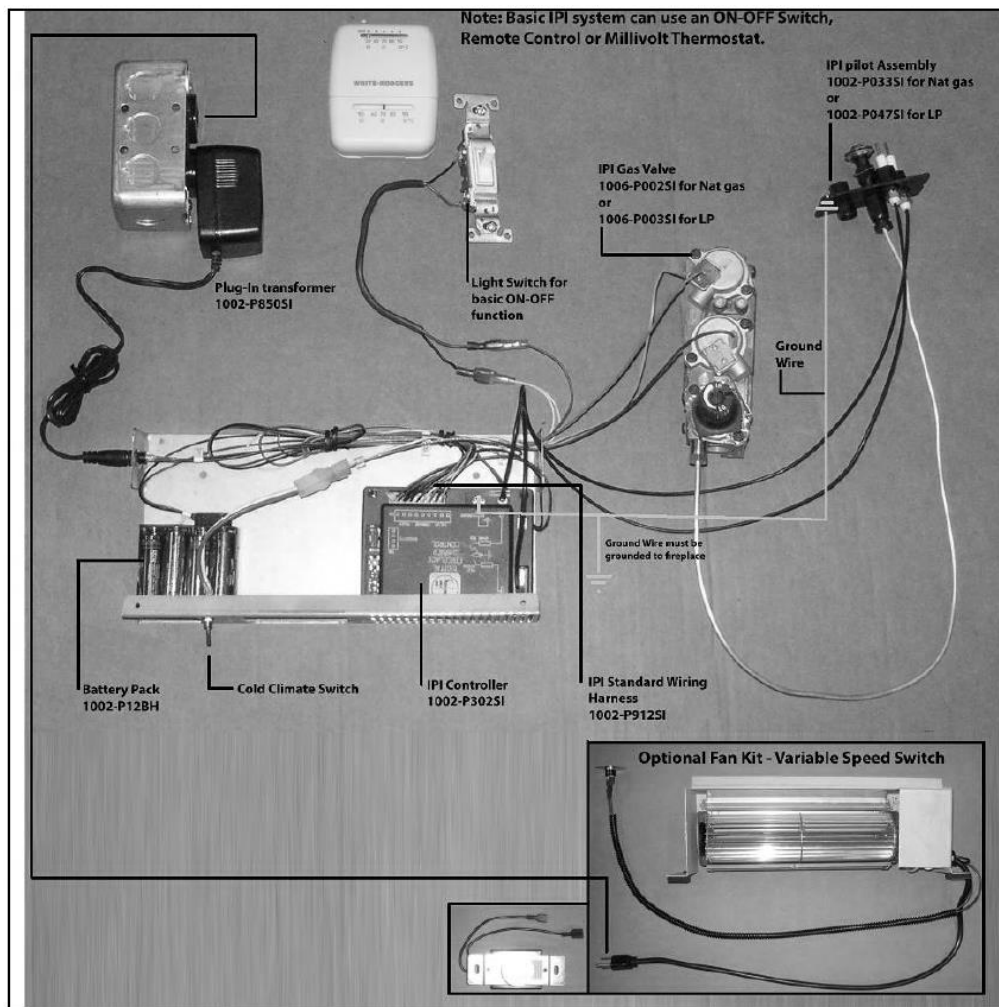

Proflame 1- Configuration #2: Remote ON/OFF and Manual HI/LO Capabilities

OPTIONAL: For units with remote HI/LO capabilities, a modulating servo is required to be installed on the valve. The connectors to this servo must be connected to the Remote Harness as shown.

SCHEMATIC

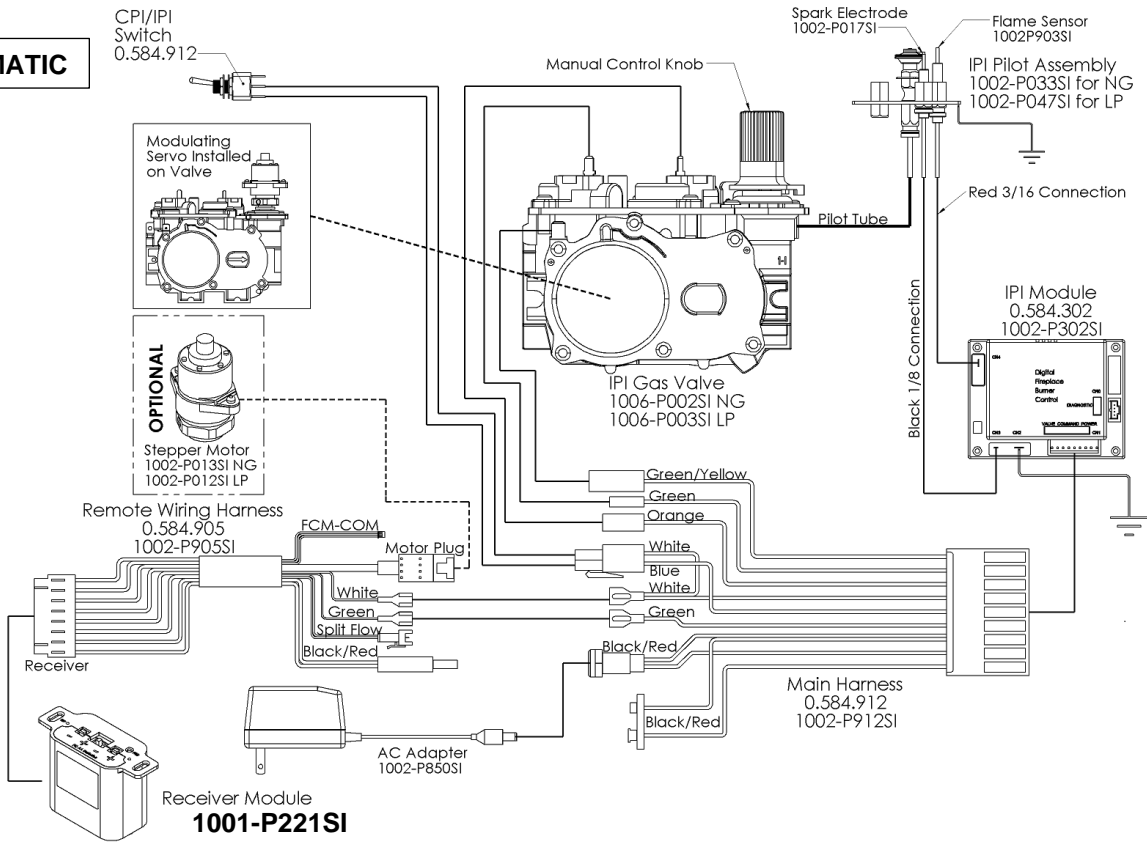

PICTURE

Note: If remote Control is used the battery Pack 1002-P12BH does not need to be used.

NOTE: Fan Option is not available on some models of fireplace. **Check with your dealer.**

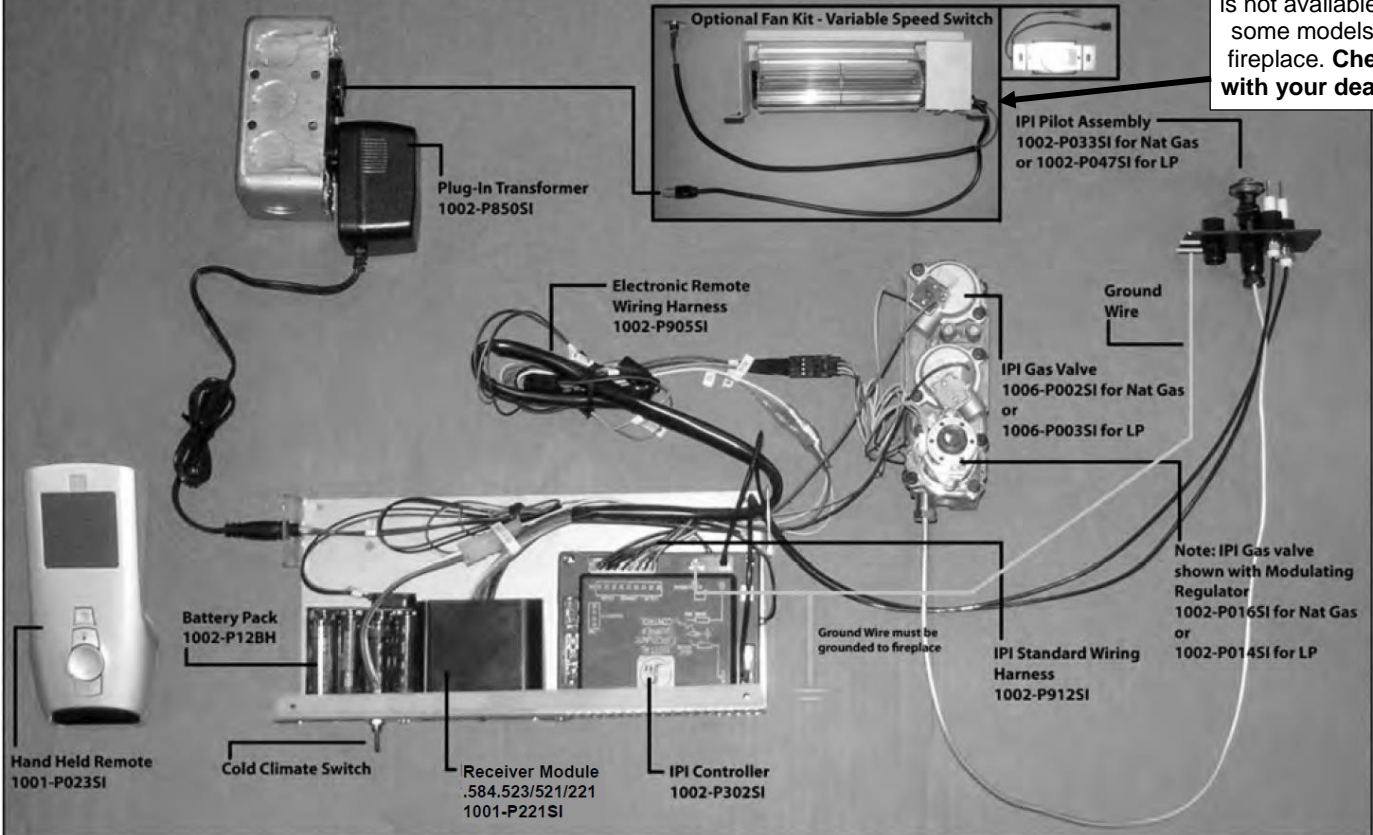

Operating the Receiver Without Batteries for GT / EGT / GTM / EGTM Remote Controls

-Wiring Harness P/N 1002-P906si required for both IPI & Millivolt systems.

-Millivolt Systems will also require Power Adapter P/N 1002-P850si.

The Remote Receiver & IPI or Millivolt system can be powered by the AC Adapter. This is advantageous if you do not want to use batteries. Simply connect the AC Adapter into the Remote Control Wiring Harness as per the diagrams below.

IPI System EGTM

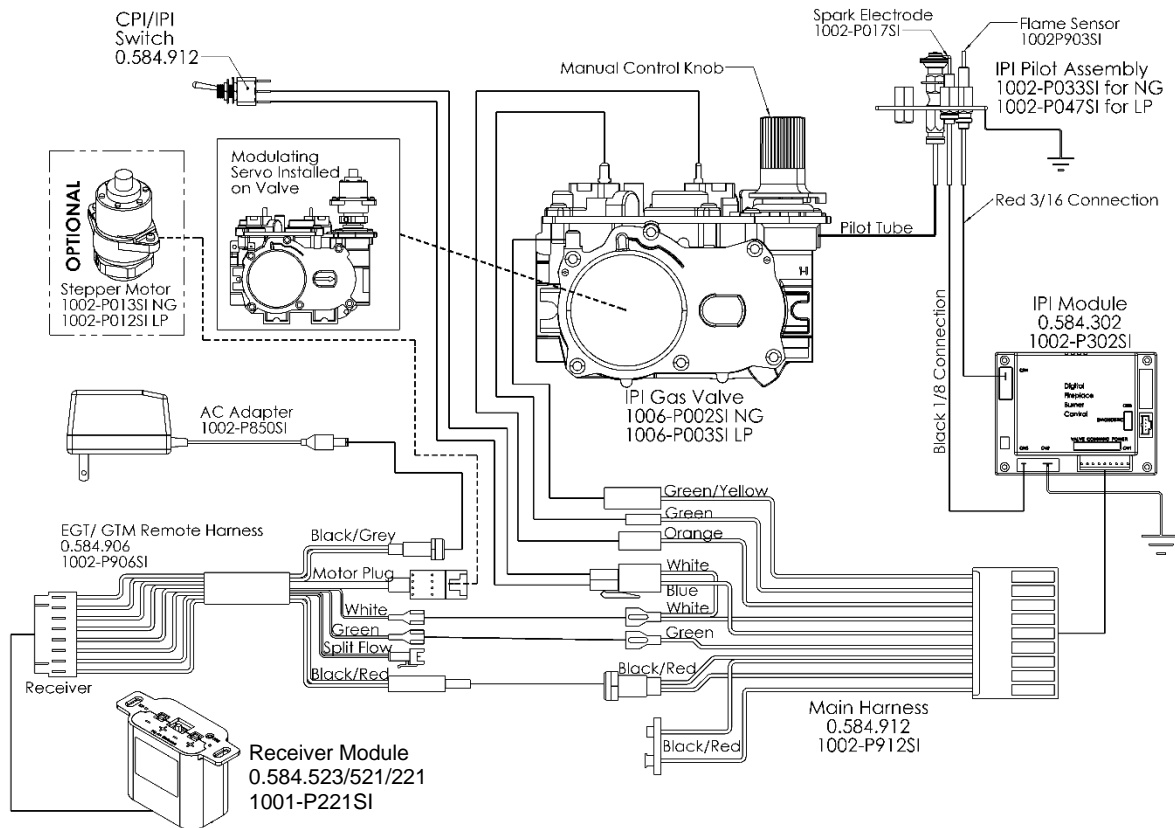

Millivolt System GTM

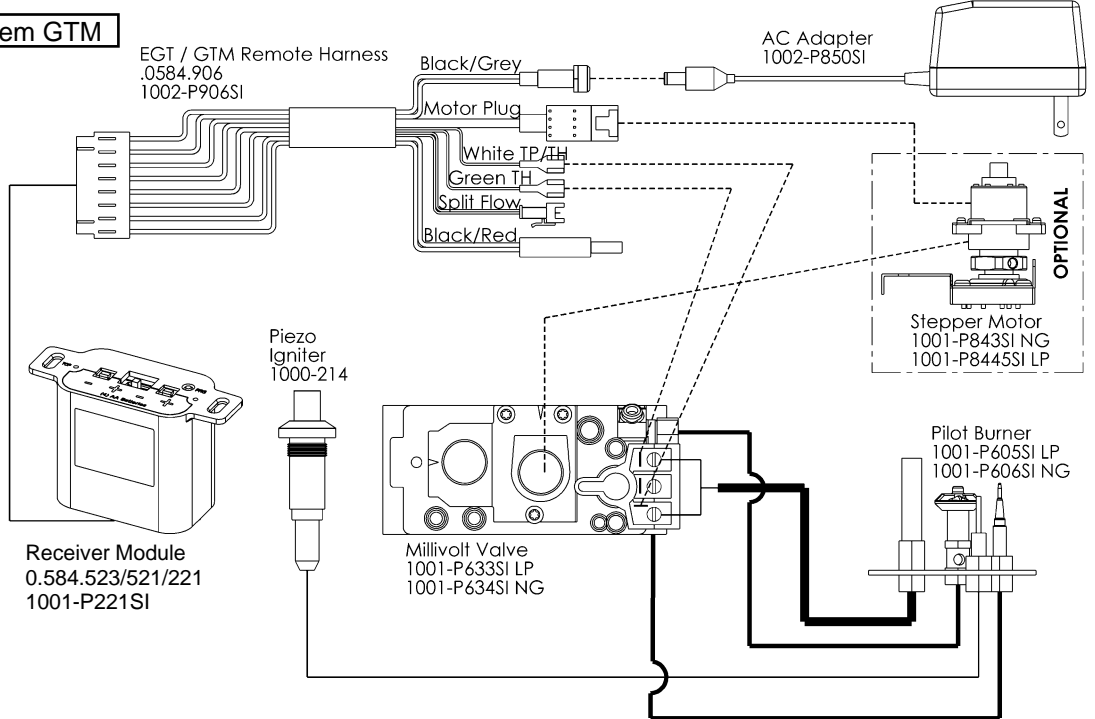

Proflame 1- Configuration #3: Remote ON/OFF, variable HI/LO, and fan capabilities

Refer to the fan installation/removal section for fan installation.

SCHEMATIC

NOTE: This Configuration is not available on all models of fireplace. Check with your dealer.

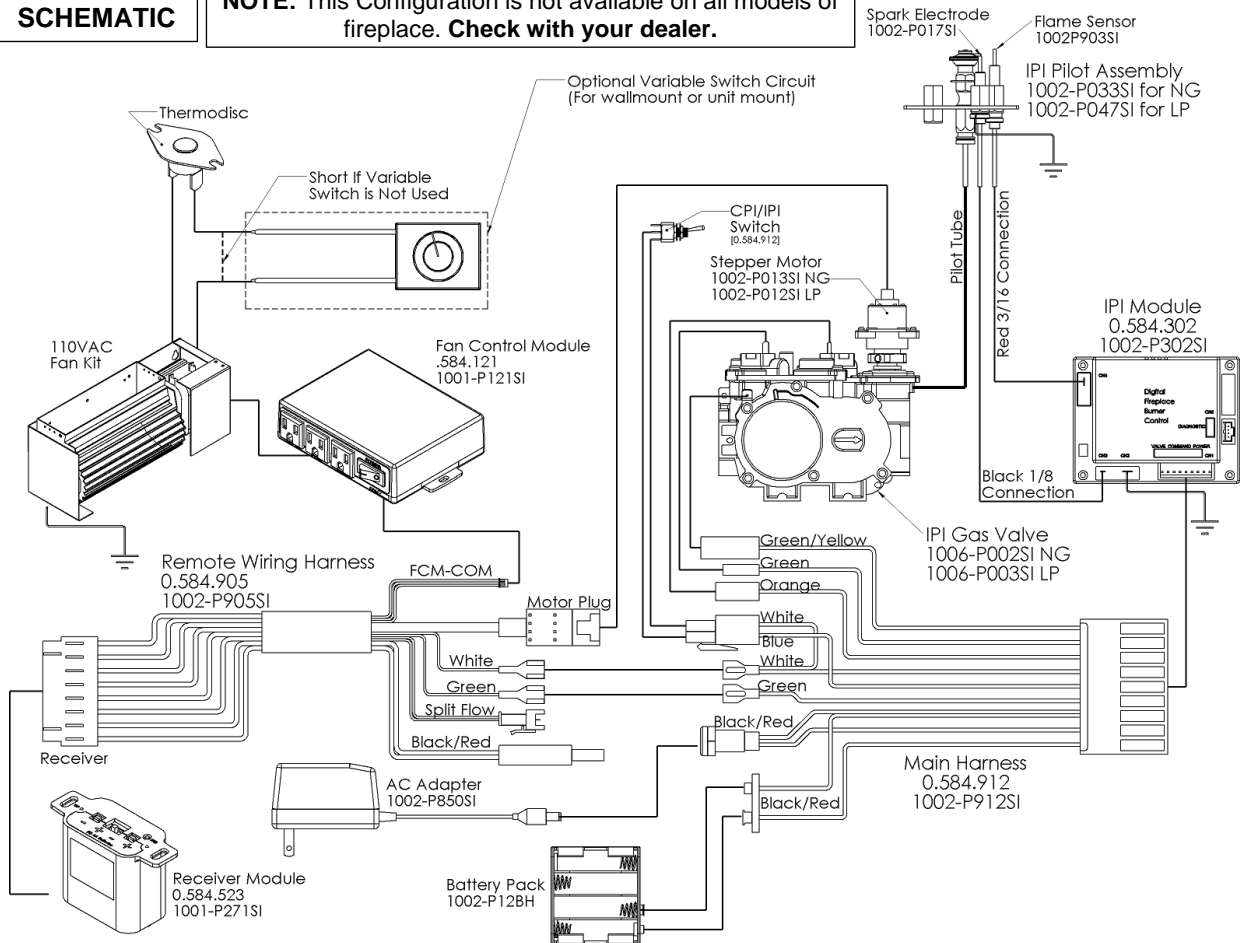

Note: If remote Control is used the battery Pack 1002-P12BH does not need to be used.

PICTURE

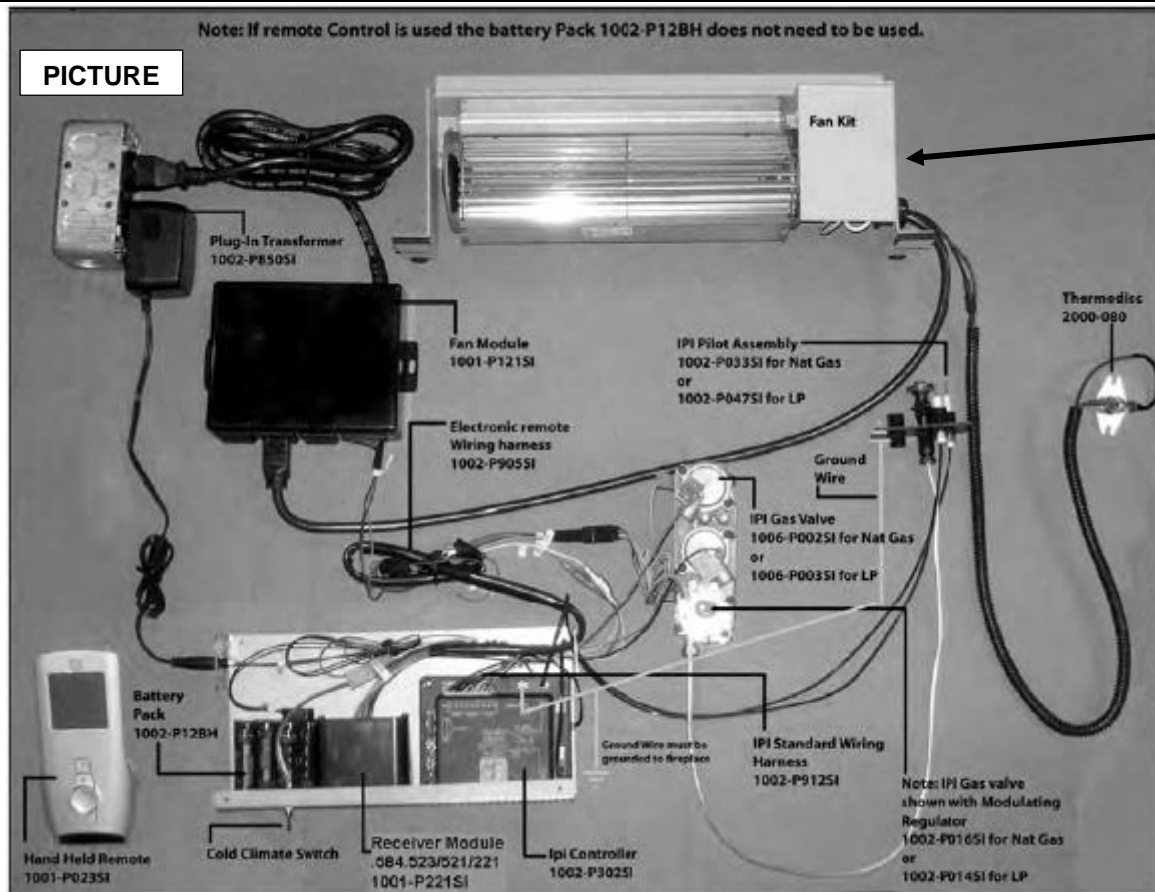

NOTE: Fan Option is not available on some models of fireplace. Check with your dealer.

IPI PROFLAME 2 - COMPONENT PARTS

PART NO.	DESCRIPTION
1.	1005-P001SI Valve IPI Proflame PF2 885.001 NG - Stepper
2.	1005-P002SI Valve IPI Proflame PF2 885.002 LP - Stepper
3.	1005-P325SI Module IPI - Proflame 2 - 584.325
4.	1005-P627SI Module IPI – Proflame 2 - Basic - 584.627
5.	1005-P924SI Harness PF2 - 584.924
6.	GTMFL Transmitter- PF2 - 584.090 - WiFi Version
6b.	1005-P042SI Transmitter- PF2 - 584.042 - Non-WiFi Version
6c.	1005-P080SI Transmitter- PF2 - 584.080 - WiFi Version
For Replacement Transmitters, Replace with Same Part Number	
7.	584-PWR-C Wire Harness PF2 – Power Cord
8.	584-X4P Terminal Block
9.	584-X10 Wire Harness PF2
10.	584-ACC01-C Wire Harness PF2 - Fan/Light
11.	584-X8-B Wire Harness PF2 - Optional Reset Harness
12.	584-X12 Optional Power Vent Harness

IPI - PF1 and PF2 Common Components

PART NO.	DESCRIPTION	
13.	1002-P033SI TC - Pilot Burner IPI (Assembled) NG 199.033	
14.	1002-P047SI TC - Pilot Burner IPI (Assembled) LP 199.047	
15.	1001-P166SI TC - Orifice Pilot NG 977.166 #62 (IPI)	
16.	1001-P168SI TC - Orifice Pilot LP 977.168 #35 (IPI)	
17.	1001-P280SI TC - Tubing W/Fittings 1/8 2.182.280	
18.	1002-P012SI IPI Stepper Kit - LP 907.012	P2 CONVERSION
19.	1002-P013SI IPI Stepper Kit - NG 907.013	
20.	1002-P014SI IPI Reg Kit - LP Hi-Lo 907.014	P1 CONVERSION
21.	1002-P016SI IPI Reg Kit - NG Hi-Lo 907.016	
22.	1002-P017SI TC - Electrode Cable & Sparker IPI 915.017 24"	
23.	1002-P119SI TC - Electrode Cable & Sparker IPI 35" (Infinite, ZCVRB47, VRB46)	
24.	1002-P12BH IPI Battery Housing 12bh347-Gr	
25.	1002-P903SI TC - Electrode Flame Sense IPI 007.253/915.903 24"	
26.	1002-P910SI TC - Electrode Flame Sense 35" (Infinite, ZCVRB47, VRB46)	

NOTE: Fan and / or Light Options are not available on some fireplaces. **Check with your dealer.**

6 Proflame Transmitter
0.584.090 - WiFi
Current Version



6b Proflame Transmitter
0.584.042 - Non-WiFi

6c Proflame Transmitter
0.584.080 - WiFi

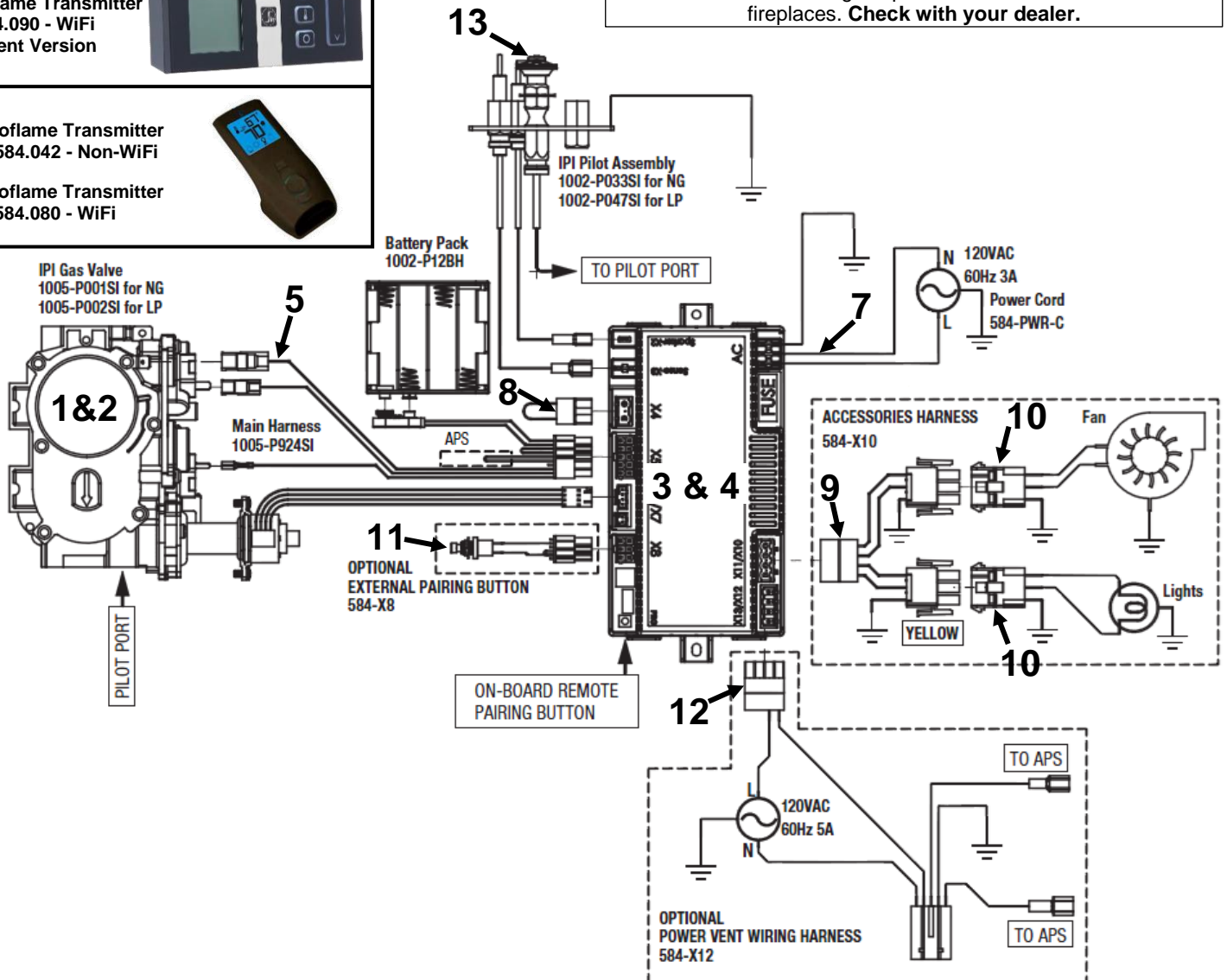
Proflame 2 IPI - IFC Module and Remote Control

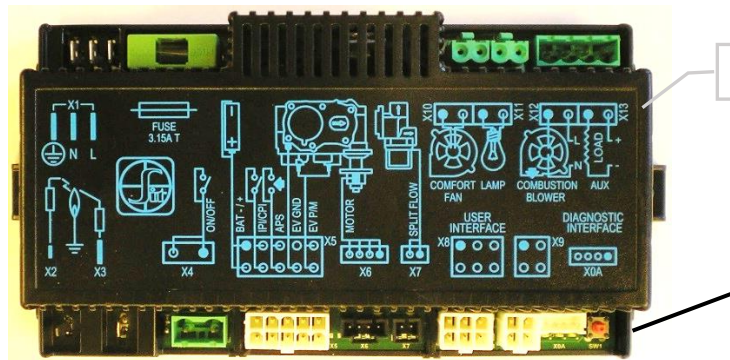
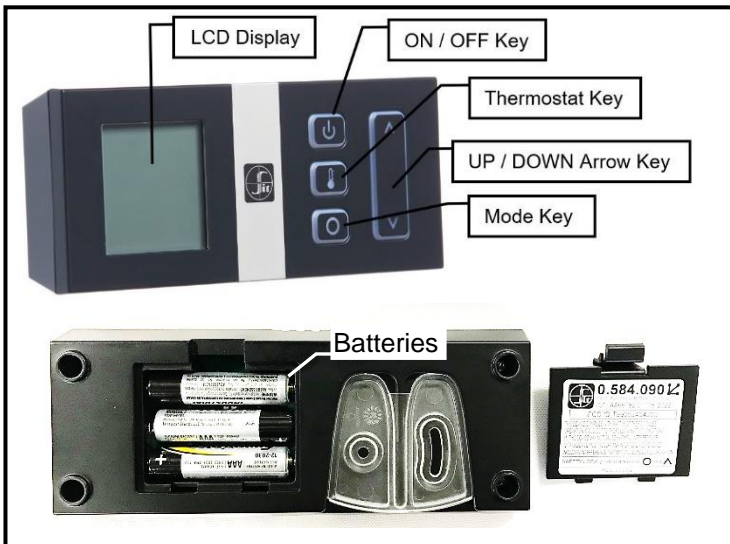

IFC Module

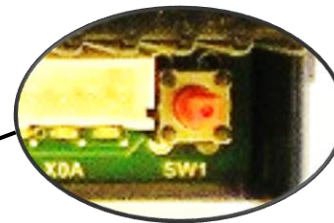

SW1 Button

Pairing Remote Control:

- Install the 3 AAA type batteries in the battery bay, located on the base of the Remote Control. Note polarity of the batteries and insert them as indicated.
- Connect the AC power supply to the IFC Module.
- Press the SW1 button on the IFC Module so the IFC will “beep” and a red LED is illuminated to indicate that the IFC Module is ready to synchronize with a Remote Control within 10 seconds. With the batteries already installed in the Remote Control, push the ON button. The receiver will “beep” four times to indicate the Remote Control’s command is accepted.

The system is now initialized.

Resetting Proflame 2 IFC Module for Manual Use

If the transmitter gets misplaced, is broken, or is no longer wanted the PF2 Module can be reset to a manual system. A manual on/off switch or thermostat may be installed at the X4 connector (this connection is Jumped at the factory) no power is required.

Note: the fireplace accessories (fan, lights) will retain the last settings they had before being reset to manual mode.

The following sequence must be followed to reset the PF2 Module:

- Press the Red **SW1** button until you hear three beeps.

- Within 10 seconds press the **SW1** button again until you hear it beep.
- The PF2 Module may now be turned on/off manually (x4 connector) by a switch (not supplied), the pilot will remain on CPI (continuous pilot ignition) mode, all other functions of main burner, fan and lights will be on the high setting.

Fan Startup and Shutdown Timings:

Fan setting is started with a delay of 5 minutes from the fireplace ignition and stopped with a delay of 12 minutes from the fireplace switching off.

Low Battery Power Detection

When the Remote Control’s batteries are low, a Battery Icon will appear on the LCD display before all power is lost. When the batteries are replaced this icon will disappear.

Battery Backup

The PF2 module is powered by line voltage (AC) with provision of battery backup in case of main power loss. Fans and lighting features will not function with the PF2 Module is powered by battery backup. It is recommended that the 4 x AA batteries are changed before each heating season.

Cold Climates – CPI Setting - Proflame 2 Remote Control

Use the CPI setting during cold weather, otherwise the fireplace may have a hard time starting up and establishing a flame. The **CPI** (Continuous Pilot Ignition) setting will keep the firebox and fireplace exhaust vent warm during cold weather. When the firebox and exhaust vent are warm, exhaust gasses will readily flow out of the firebox.

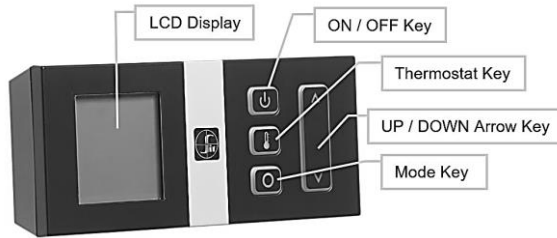

If the firebox and venting are too cold, there is resistance due to the heavy cushion of cold air, and combustion gasses may not rise into the exhaust vent, thus causing the fireplace to cycle or **Lockout** (if this happens see **Lockout Reset Procedures** below).

NOTE: The pilot system for this appliance may be equipped with a **Seven Day Timer**, in which case the pilot flame will be extinguished if the main burner has not been turned ON for seven days. This Seven Day Cycle is reset every time the main burner is cycled ON / OFF and the pilot remains lit. If more than seven days has passed since the main burner has been cycled ON / OFF and the pilot is also out, follow the procedures described in this manual to light the pilot.

To switch from IPI to CPI Mode:

1. Turn the fireplace OFF using the **ON / OFF Key**.

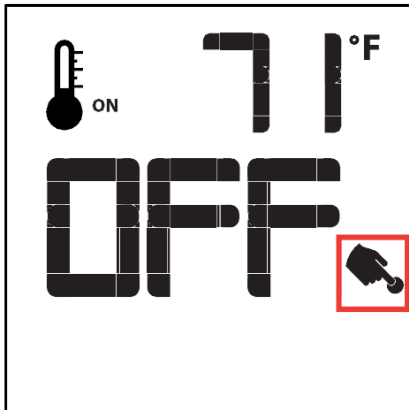

2. Press the **Mode Key**. Display will appear as below.

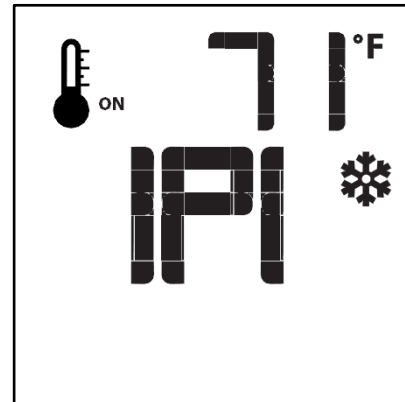

3. Press UP on the **UP / DOWN Arrow Key**. Display will show **CPI**.

The module in the fireplace will beep once to confirm command.

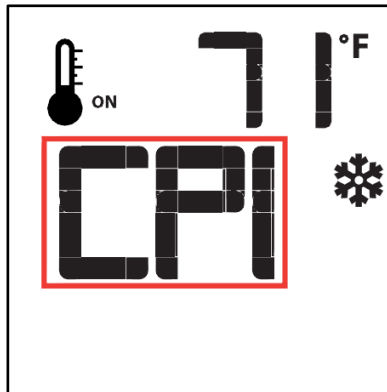

TO RETURN TO IPI (INTERMITTENT PILOT) MODE:

Repeat steps one and two, and then press DOWN on the **UP / DOWN Arrow Key**.

The module in the fireplace will beep once to confirm command.

Lockout Reset Procedures – Proflame 2

If the fireplace has cycled too many times in a short period of time, it will shut down and become unresponsive to any new command.

The LED light on the Proflame 2 module in the fireplace will be flashing red.

This condition is a **Lockout** state.

Lockout Reset Procedure:

1. Disconnect power from the Proflame 2 module in the fireplace for 10 seconds. This includes removing the backup batteries.
2. Once the 10 second interval has passed, reconnect power and reinstall backup batteries. The pilot should now try to light.
3. If the fireplace does not come on, call your fireplace technician.

Proflame 2 Remote Control

Remote-Flame Control

The proflame has six (6) flame levels. With the system on, and the flame level at the maximum in the appliance, pressing the Down Arrow Key once will reduce the flame height by one step until the flame is turned off.

The Up Arrow Key will increase the flame height each time it is pressed. If the Up Arrow Key is pressed while the system is on but the flame is off, the flame will come on in the high position. (Fig. 7 & 8) A single "beep" will confirm reception of the command.



Fig. 7: Flame Off

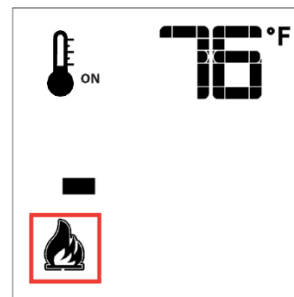

Flame Level 1

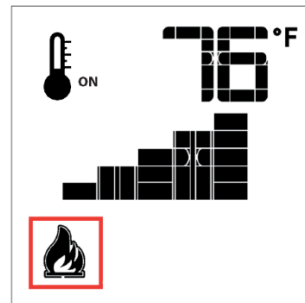
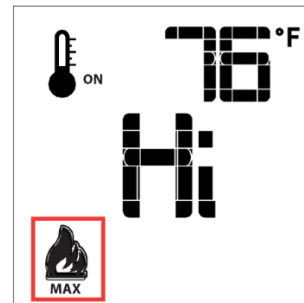

Fig. 8: Flame level 5



Flame Level Maximum

Room Thermostat (Transmitter Operation)

The Remote Control can operate as a room thermostat. The thermostat can be set to a desired temperature to control the comfort level in a room.

To activate this function, press the Thermostat Key (Fig. 1). The LCD display on the Transmitter will change to show that the room thermostat is "ON" and the set temperature is now displayed (Fig. 9). To adjust the set temperature, press the Up or Down Arrow Keys until the desired set temperature is displayed on the LCD screen of the Transmitter.

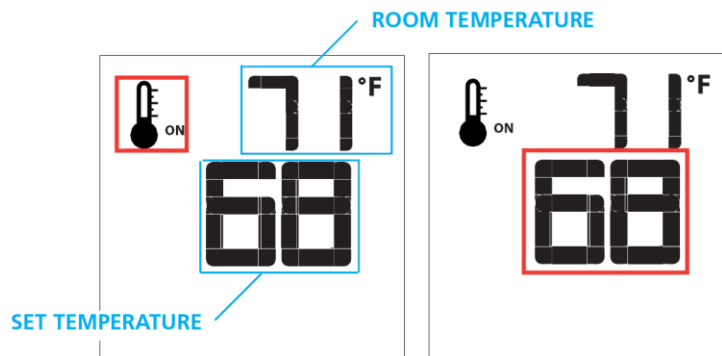

Fig. 9

Fig. 10

Smart Thermostat (Transmitter Operation)

The Smart Thermostat function adjusts the flame height in accordance to the difference between the set point temperature and the actual room temperatures. As the room temperature gets closer to the set point the Smart Function will modulate the flame down. To activate this function, press the Thermostat Key (Fig. 1) until the word "SMART" appears to the right of the temperature bulb graphic (Fig. 11).

To adjust the set temperature, press the Up or Down Arrow Keys until the desired set temperature is displayed on the LCD screen of the Transmitter (Fig. 12).

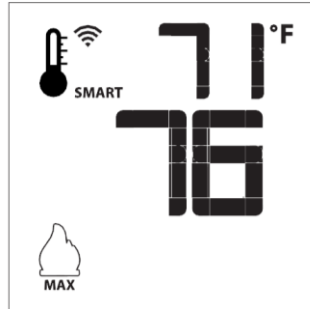

Fig. 11: Smart flame function

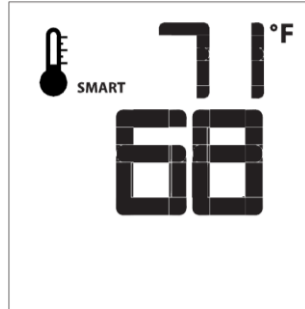

Fig. 12

Note:
When Smart Thermostat is activated, manual flame height adjustment is disabled.

Fan Speed Control

If the appliance is equipped with a hot air circulating fan, the speed of the fan can be controlled by the Proflame system. The fan speed can be adjusted through six (6) speeds. To activate this function use the Mode Key (fig.1) to index to the fan control icon (Fig. 13). Use the Up/Down Arrow Keys (Fig.1) to turn on, off or adjust the fan speed (fig. 14). A single "beep" will confirm reception of the command.



Fig. 13

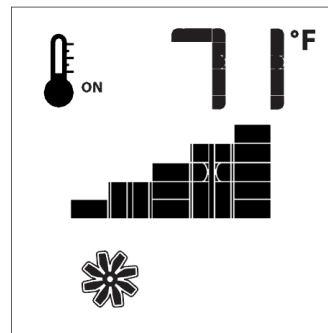

Fig. 14

Remote dimmer control (Halogen lights only)

The auxiliary function controls the AUX power outlet by the dimmable light control. To activate this function use the Mode Key (fig. 1) to index to the AUX icon (fig. 15 & 16).

The intensity of the output can be adjusted through six (6) levels. Use the Up/Down Arrow Keys (Fig.1) adjust the output level (fig. 16). A single "beep" will confirm reception of the command.

Note:
This function is only available in Room Thermostat or Smart Thermostat Control Mode.



Fig. 15

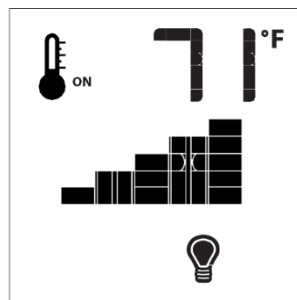
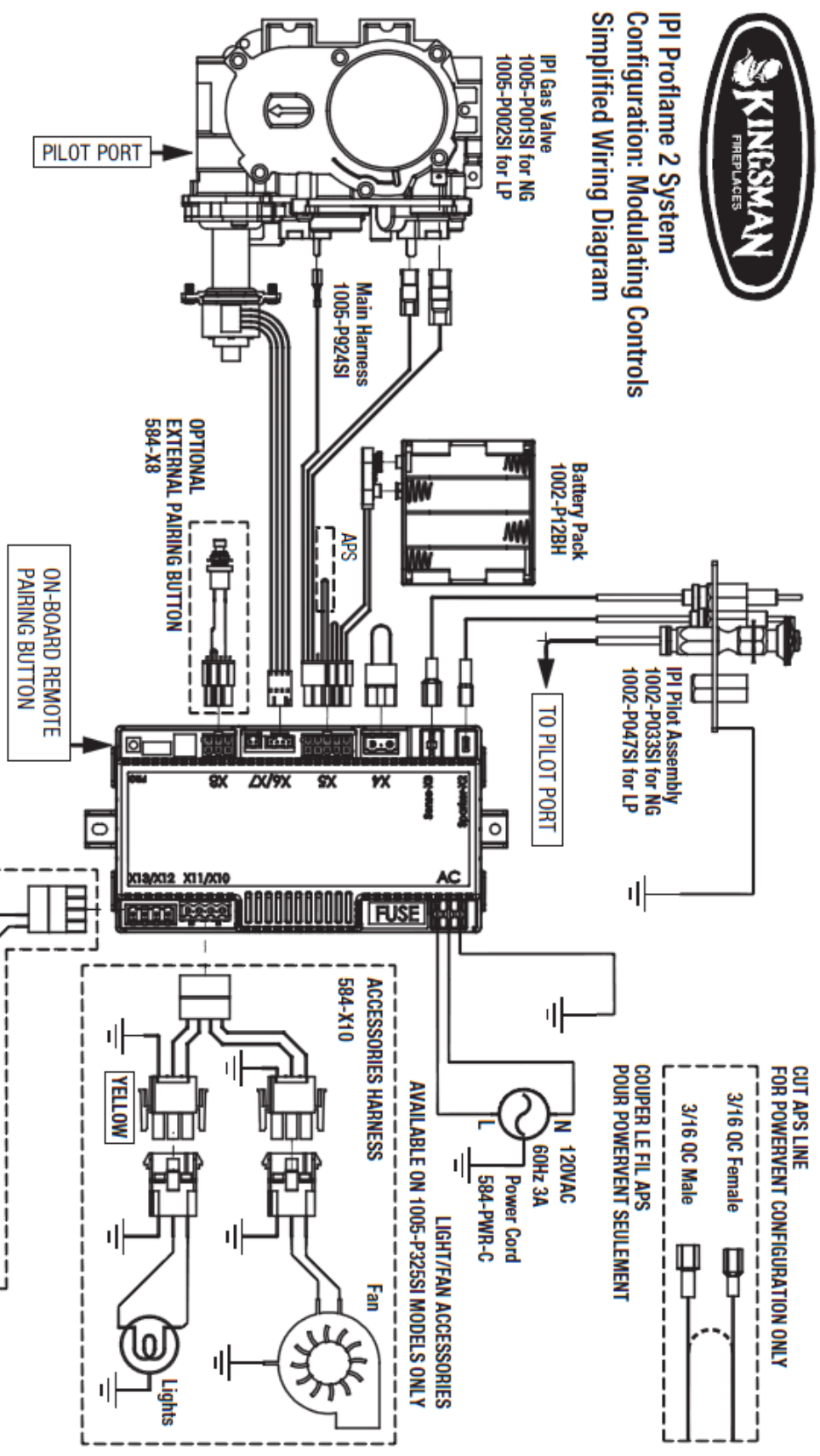

Fig. 16



IPI Proflame 2 System Configuration: Modulating Controls Simplified Wiring Diagram



CUT APS LINE
FOR POWERVENT CONFIGURATION ONLY

3/16 QC Female

3/16 QC Male

COUPER LE FIL APS
POUR POWERVENT SEULEMENT

AVAILABLE ON 1005-P325SI MODELS ONLY

LIGHT/FAN ACCESSORIES

584-X10

Fan

Lights

YELLOW

OPTIONAL
POWER VENT WIRING HARNESS
584-X12

120VAC
60Hz 5A

TO APS

TO APS

Manufactured by: Kingsman Fireplaces
Fabriqué par: 2340 Logan Avenue
Winnipeg, MB R2R 2V3

For use with all Kingsman manufactured IPI Proflame 2 models, for all types of gas noted on rating plate. Supply 120VAC 60Hz 3A, 6 volts battery backup.

Pour utilisation avec tous les modèles IPI Proflame 2 fabriqués par Kingsman, pour tous les types de gaz noté sur la plaque signalétique. Voltage d'alimentation: 120VAC 60Hz 3A et 6 volts pour le bloc-piles de secours.

This component should be installed by a qualified service agency.
Cette composante doit être installée par une entreprise de service qualifiée.

Part #1005-P2SC8H

Vent Terminal Clearances

NOTE: A HORIZONTAL VENT CERTIFIED GUARD (SAFETY CAGE) IS AVAILABLE WHEN REQUIRED BY LOCAL CODES.

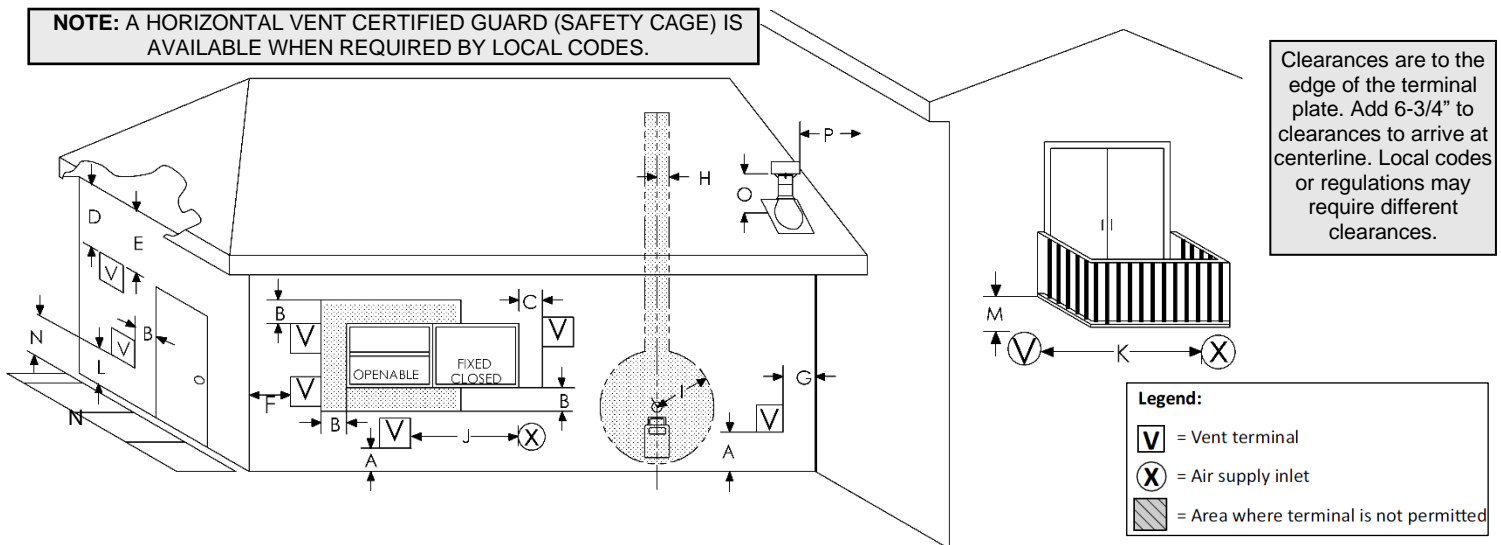

		Canadian installations ¹	US installations ²
A	Clearance above grade, veranda, porch, deck, or balcony	12 in (30 cm)	12 in (30 cm)
B	Clearance to window or door that may be opened	6 in (15 cm) for appliances ≤ 10,000 Btu/h (3 kW), 12 in (30 cm) for appliances > 10,000 Btu/h (3 kW) and ≤ 100,000 Btu/h (30 kW), 36 in (91 cm) for appliances > 100,000 Btu/h (30 kW)	6 in (15 cm) for appliances ≤ 10,000 Btu/h (3 kW), 9 in (23 cm) for appliances > 10,000 Btu/h (3 kW) and ≤ 50,000 Btu/h (15 kW), 12 in (30 cm) for appliances > 50,000 Btu/h (15 kW)
C	Clearance to permanently closed window	12 inches (30cm) recommended to prevent condensation on window	12 inches (30cm). 9 inches (23cm) for appliances 50,000 Btu's and lower
D	Vertical clearance to ventilated soffit located above the terminal within a horizontal distance of 2 feet (61 cm) from the center line of the terminal	18 inches (46cm)	18 inches (46cm)
E	Clearance to unventilated soffit	12 inches (30cm)	12 inches (30cm)
F	Clearance to outside corner	3" *	3" *
G	Clearance to inside corner	3" *	3" *
H	Clearance to each side of center line extended above meter/regulator assembly	3 ft (91 cm) within a height 15 ft (4.5 m) above the meter/regulator assembly	3 ft (91 cm) within a height 15 ft (4.5 m) above the meter/regulator assembly
I	Clearance to service regulator vent outlet	3 ft (91 cm)	3 ft (91 cm)*
J	Clearance to non-mechanical air supply inlet to building or the combustion air inlet to any other appliance	6 in (15 cm) for appliances ≤ 10,000 Btu/h (3 kW), 12 in (30 cm) for appliances > 10,000 Btu/h (3 kW) and ≤ 100,000 Btu/h (30 kW), 36 in (91 cm) for appliances > 100,000 Btu/h (30 kW)	6 in (15 cm) for appliances ≤ 10,000 Btu/h (3 kW), 9 in (23 cm) for appliances > 10,000 Btu/h (3 kW) and ≤ 50,000 Btu/h (15 kW), 12 in (30 cm) for appliances > 50,000 Btu/h (15 kW)
K	Clearance to a mechanical air supply inlet	6 ft (1.83 m)	3 ft (91 cm) above if within 10 ft (3 m) horizontally
L	Clearance above paved sidewalk or paved driveway located on public property	7 ft (2.13 m)	*(Notes: 2)
M	Clearance under veranda, porch, deck, or balcony	12 in (30 cm)‡	12 in (30 cm) *
N	Where a vent termination may cause hazardous frost or ice accumulations on adjacent property surfaces	** (Notes: 1)	*(Notes: 2)
O	Clearance above highest point of exit on roof	18 in (45cm)	18 in (45cm)
P	Clearance to perpendicular or adjacent wall	24 in (60cm)	24 in (60cm)

Notes:

1) In accordance with the current CSA B149.1, Natural Gas and Propane Installation Code.

2) In accordance with the current ANSI Z223.1/NFPA 54, National Fuel Gas Code.

* Clearance in accordance with local installation codes and the requirements of the gas supplier.

** A vent shall not terminate directly above a paved sidewalk or paved driveway that is located between two single family dwellings and serves both dwellings. Note: This does not apply to non-condensing appliances (Province of Ontario ONLY).

‡ Permitted only if veranda, porch, deck, or balcony is fully open on a minimum of two sides beneath the floor.

It is imperative that the vent termination be located observing the minimum clearances as shown. There must not be any obstruction such as bushes, garden sheds, fences, decks or utility buildings within 24" from the front of the termination plate.

Do not locate termination where excessive snow or ice build-up may occur. Be sure to check vent termination area after snow falls and clear to prevent accidental blockage of venting system. When using snow blowers, make sure snow is not directed towards vent termination area. Venting terminal shall not be recessed into a wall or siding. If finishing the outside wall with vinyl or wood siding it is **required** that a Siding Shield be installed, Part Number ZDVSSLR.

General Vent Installation Information

⚠ WARNING: DO NOT mix parts from different systems unless stated in the manual.

This gas appliance is approved to be vented either through the side wall or vertically through the roof. Only Kingsman Flex (Z-Flex) Venting Kits and components specifically approved and LABELED for this appliance may be used. This appliance is also approved for use with MG-DuraVent Direct Vent system (DirectVent Pro and DirectVent Pro Concentric Flex), BDM Pro Form Direct Vent, Ameri-Vent Direct Vent Pipe System, ICC Excel Direct, Metal Fab Sure-Seal DV and Selkirk Direct Temp.

Rigid or Hard Pipe

When using MG DuraVent, Ameri-Vent pipe, BDM Pro Form Direct Vent, ICC Excel Direct, Metal Fab Sure-Seal DV and or Selkirk Direct Temp a DuraVent hard pipe adapter must be used (part # ZDVDF A for fireplaces, and part # ZDV DKA for Stoves and Serene Series). Follow installation instructions provided by MG DuraVent/Ameri-Vent/Selkirk Direct Temp, ICC Excel Direct, and Metal Fab Sure-Seal DV for installation of pipe and adhere to the clearance to combustibles provided in this manual.

Apply a bead of Mill Pac high temp sealant at the flue of the appliance when using a DuraVent adapter.

NOTE: It is critical to the proper and safe operation of this fireplace that on all connections the inner liner and the outer casing are both caulked with liberal amounts of sealant. Do not use any kind of tape or silicone other than that recommended in this manual. Use Mill Pac Sealant.

NOTE: These actions are essential for proper resealing or reinstallation of the vent-air intake system.

REMEMBER THAT A 1/4" VERTICAL RISE IS REQUIRED FOR EVERY 12" OF HORIZONTAL RUN.

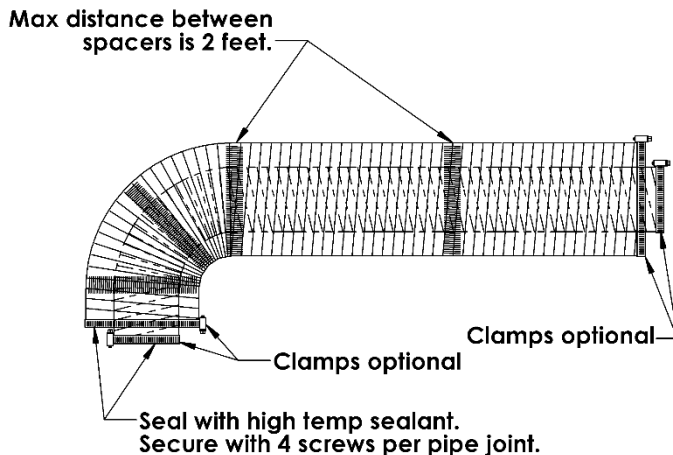

Flex Pipe Venting

Kingsman Flex pipe is shipped in unexpanded length. When installing pipe expand the lengths. Pipe can be expanded to twice their lengths e.g., 4ft. to 8ft. Fully expand pipe and cut off excess. Do not use more than 2 couplers to extend short pipes. Single sections are preferred in an installation attaching at the fireplace and termination.

Place the spring spaces provided approximately every two feet to stabilize 4" flex in the center of 7" flex. When forming bends place spring in bend or before and after. (See Fig. 1). Horizontal runs require support metal straps every 2 feet. In offset installation support straps should be used to stabilize pipe.

Expand 4" and 7" flex pipe to the point that the 7" protrudes approximately 2 to 3 inches past outer wall and the 4" flex protrudes approximately 2 to 3 inches past the 7" flex. (See Fig. 1). Attach the 4" pipe to the termination first and secure with sealant and screws then attach the 7" flex to the termination with caulking and screws. Termination may then be moved back to the outer wall and attached to home screwing into the framing. Silicone around termination to waterproof. If siding shield is going to be used attach this using same attaching hole as the top of termination after termination has been caulked for water proofing.

Use Hi Temp Sealant

Apply a bead of Mill Pac high temp sealant to all joints and use four screws to secure each pipe at fireplace, termination and any joint if joining any sections of pipe.

Preventing Moisture Problems

Insulate wall thimbles and attic insulation shields for vertical attic terminations with non-combustible mineral wool Insulation (Roxul, Rockwool, Thermafiber UltraBatt, etc.). Attach and seal the outer perimeter of the wall thimble or attic insulation shield to the existing vapor barrier.

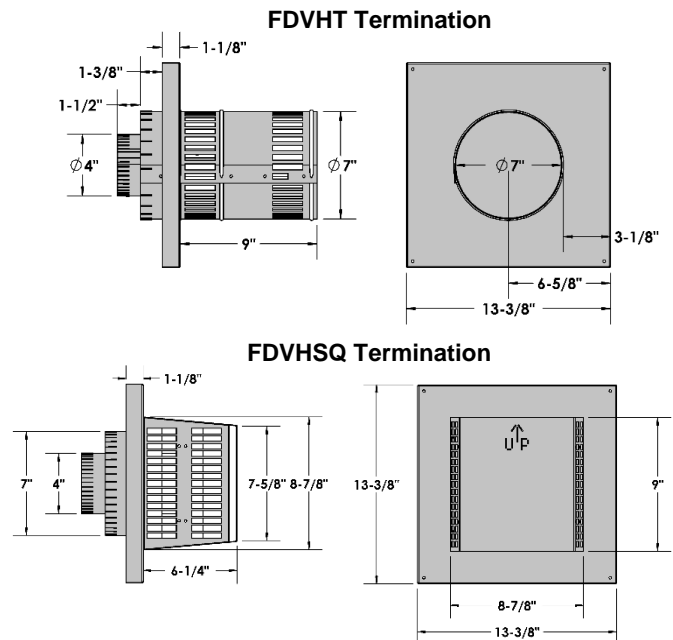

- To determine the minimum distance from the bottom of fireplace to center of vent see the Framing Your Gas Fireplace section. Cut a hole through the wall allowing for an 11" x 11" (inside diameter) in combustible walls for wall thimble or an 8" diameter hole in a non-combustible wall (See Figure 2).
- For the clearance to combustibles above a 90-degree bend see Clearance to Combustibles section.
- Select the approximate vent length, precise measurements are not needed as your flex pipe can be expanded to twice its shipped length for ease of installation.
- To install wall thimble center over 11" x 11" (inch) framing from both sides of wall and secure. Route flex vent pipe through wall thimble (See Figure 1).
- Before joining pipes, apply a bead of high temperature sealant (Mill Pac) to end of pipe. First attach the four-inch (4") flue pipe to the vent termination with sealant, and secure with the four screws provided. At this time make sure the spacer springs are attached to the (4") flex pipe as required. Then attach the seven-inch (7") pipe by the same method.
- Mount vent termination and seal to wall using caulking around the wall thimble to weather proof. After installing the vent termination, double check to make sure the pipe extends properly through wall thimble and into vent termination.
- Before joining pipes to fireplace flue, apply a bead of high temperature sealant (Mill Pac) to end of pipe. First attach the four-inch (4") flue pipe to fireplace with sealant, and secure with the four screws provided. At this time verify that the spacer springs are attached properly to the (4") flex pipe as required. Then attach the seven-inch (7") pipe by the same method.
- Support horizontal pipes every two (2) feet (61 cm) with metal strap bands. Re-check fireplace to make sure it is levelled and properly positioned and secured.
- Support vertical pipes to maintain a minimum of 1" or greater clearance to combustibles with metal strapping bands.
- If finishing the outside wall with vinyl or wood siding it is **required** that a Siding Shield be installed, Part Number ZDVSSLR.

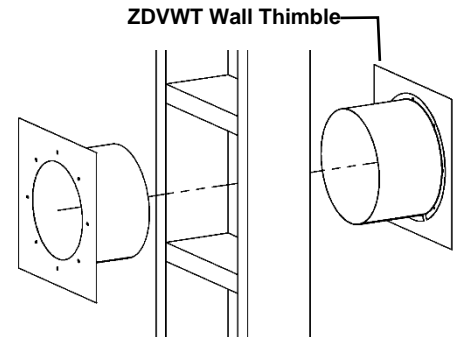

Note: Vent Termination must not be recessed into wall or siding.

WARNING: A HORIZONTAL VENT CERTIFIED GUARD (SAFETY CAGE) IS AVAILABLE WHEN REQUIRED BY LOCAL CODES.

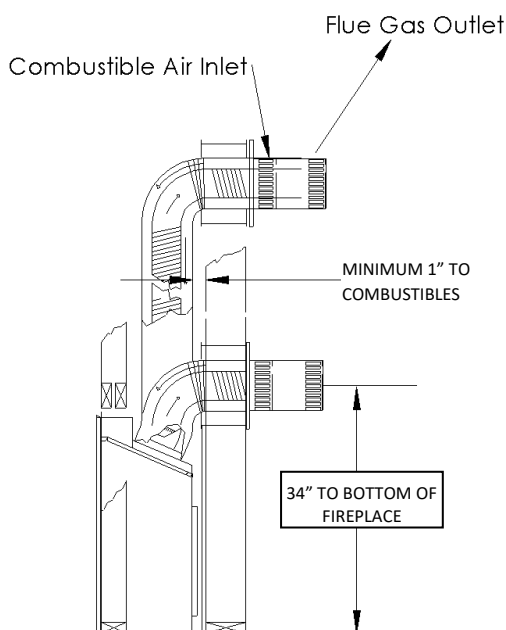

Figure 1

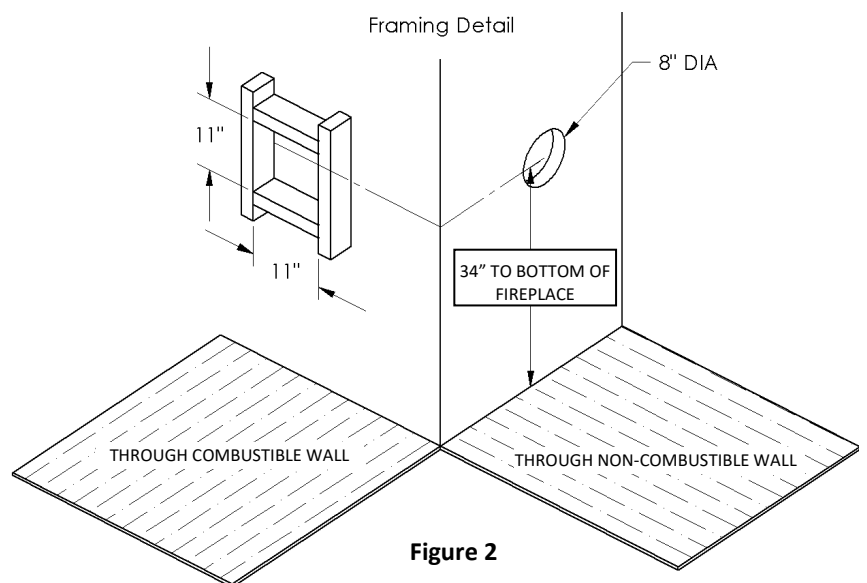

Figure 2

Venting Routes And Components

Since it is very important that the vent system maintain its balance between the combustion air intake and the flue gas exhaust, certain limitations as to vent configurations apply and must be strictly adhered to.

The table showing the relationship between vertical and horizontal side wall venting will help to determine the various vent lengths.

The maximum horizontal run with the 90 degree bend at the fireplace flue outlet is 4 ft/122cm (Figure #1). The maximum horizontal run is 20 ft/6.1 m when the vertical run is 7 ft/2.1m (Figure #2). Note: 1/4" vertical rise is required for every 12" of horizontal run.

The maximum number of 45 degree bends per side wall installation is two (2) in the horizontal run and then you must reduce the length of the horizontal by 18 inches for each 45 degree bend.

The maximum vertical run is 40 ft/12.2 meters.

Special Note: For each 45 degree bend installed in the horizontal run, the length of the horizontal run must be reduced by 18" (45cm). This does not apply if the 45 degree bends are installed on the vertical part of the vent system.

Example: If according to the table, the length of the horizontal run is 10 feet, and two 45 degree bends are required, the horizontal run length must be reduced to 7 feet.

2 additional 90° bends or equals are allowed. The horizontal run must be reduced by 36" per each 90° bend, or 18" per each 45° bend.

Important: Always locate the fireplace in such a way that a minimum of offsets and/or horizontal runs are required. 1/4" vertical rise is required for every 12" horizontal run.

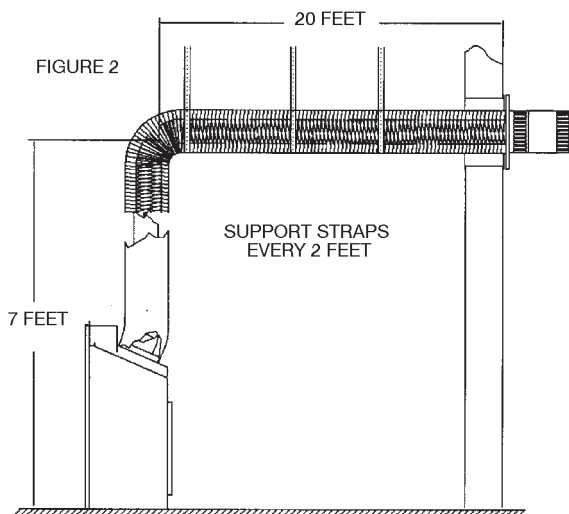
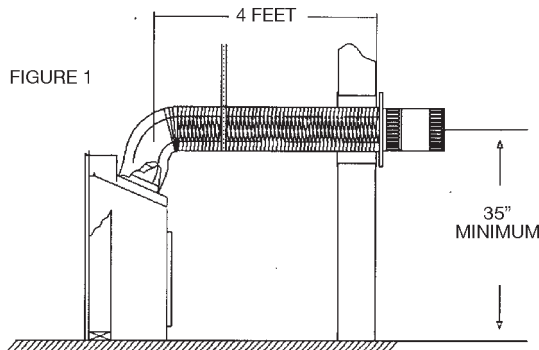

How To Use The Horizontal Vent Table

1. Determine the height of the system and the number of bends required.
2. Having determined the vertical distance determine the maximum horizontal section allowed.
3. Vent table has been established for 90° horizontal/vertical runs. With use of flex pipe distance not having 90° bends will not fall into vent table standards. See Fig. B.

Horizontal Venting Table From Bottom of Fireplace

for venting to a maximum of 40 ft. (12.2 meters)

Total Vertical		Max Total Horizontal	
Feet	Meters	Feet	Meters
4	1.2	5	1.5
5	1.5	8	1.2
6	1.8	12	3.7
7	2.1	20	6.1
8	2.4	20	6.1
9	2.7	20	6.1
10	3.0	20	6.1
11	3.4	20	6.1
12	3.7	20	6.1
13	4.0	20	6.1
14	4.3	20	6.1
15	4.6	20	6.1
17	5.2	20	6.1
18	5.5	20	6.1
19	5.8	20	6.1
20	6.1	20	6.1
25	7.5	15	4.6
30	9	10	3.0
40	12.2	0	0

Example A:

If the vertical dimension from the floor of the fireplace is 6ft, the horizontal run to the wall flange of the vent termination must not exceed 12ft.

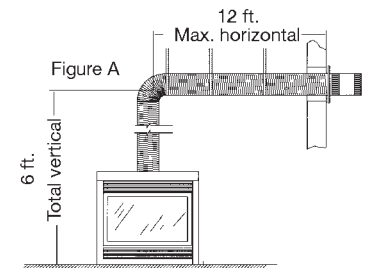

NOTE: The final location of the fireplace must be such that the horizontal vent dimensions fall within those stated on the graph. The Maximum Vertical vent run is 40ft. (12.2 meters).

Important: Minimum clearance between vent pipes and combustible materials is 1 inch (25mm).

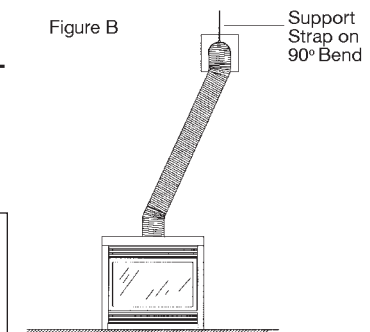

It is required for **Propane Horizontal Installations** that the venting should be a minimum of one foot vertical off the flue before the elbow on any horizontal runs of one foot or greater. This allows for cleaner combustion and greatly reduces carboning and cleaning of glass. (Does not apply to Back Flue Models).

Two snorkel terminations are available if a vertical rise is necessary on the exterior side of a building:

Z47ST24 (24" Tall, 14-1/2" Center to Center) **Z47ST36** (36" Tall, 26-1/2" Center to Center)

Follow standard horizontal venting installation procedures. If the Snorkel Termination is to be located below grade, a window well is recommended with adequate and proper drainage as per local codes. Leave 2" clearance below snorkel to prevent water from entering the Snorkel Termination. Do not enclose the Snorkel within a wall or other type of enclosure and **do not back fill**. Ensure that grade level slopes away from the building. Follow all local codes.

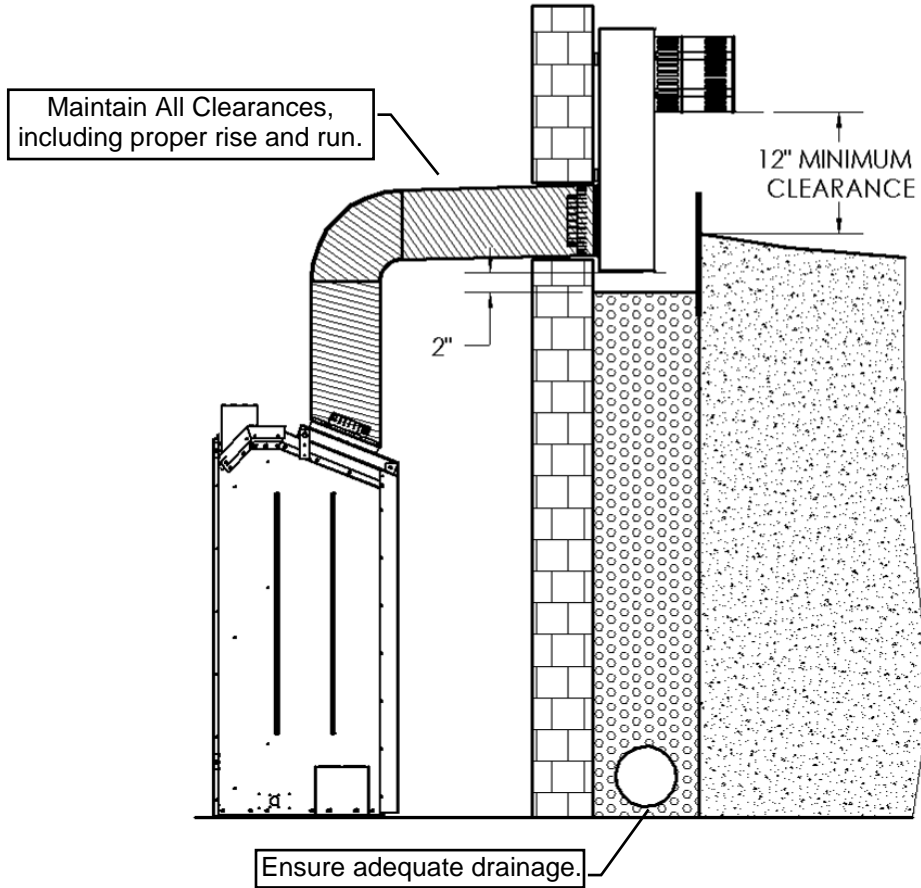

-FOLLOW ALL LOCAL CODES-

- A safety cage (Z57STSC) is also available. Place safety cage over snorkel and mount with [4] DT screws (supplied with safety cage).

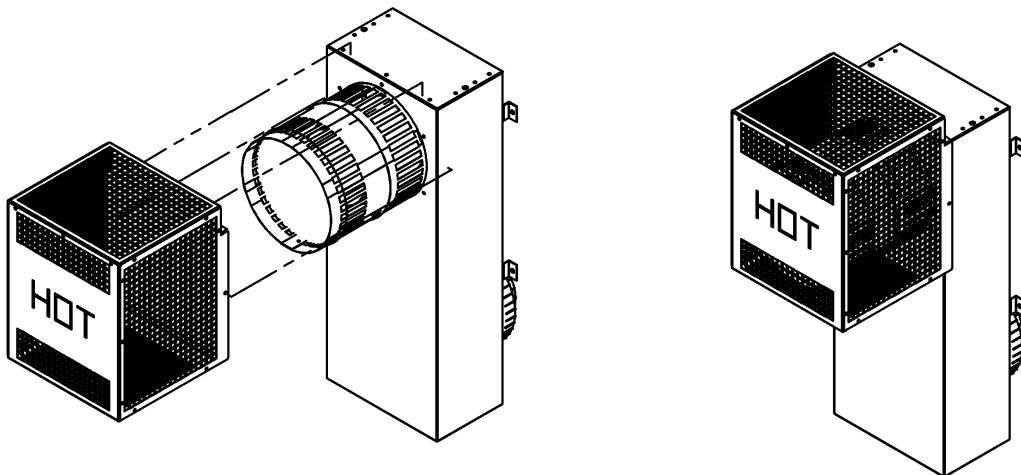

Venting Straight Up Through Roof

An Attic Insulation Shield must be installed where the vent passes from a lower living space into an attic space where the chimney is not enclosed. It is designed to keep insulation materials away from the chimney. When installing the Attic Insulation Shield where the chimney passes from a living space to an attic space, install the shield from below and nail in place using 1" spiral nails. A fire stop must be installed on the bottom side of the joists when passing through a ceiling or floor. If an attic insulation shield is to be used, a fire stop is not required.

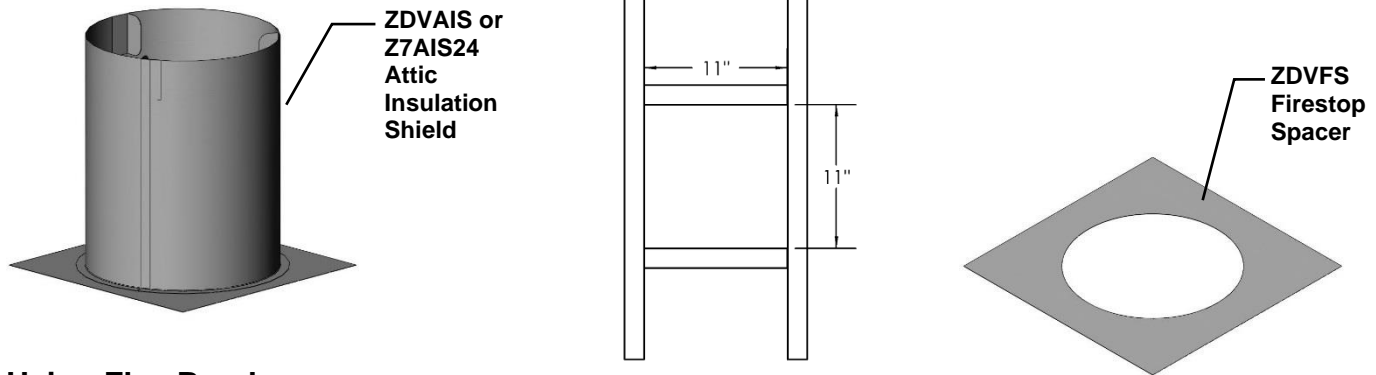

Using Flex Bends

Avoid cutting joists by offsetting the flex pipe.

When using 45° bends a bend support is required directly above the highest bend.

When installing a bend in a joist area a minimum of 4" clearance to combustibles to the top of bend must be maintained, sides and bottom of pipe, a 1" clearance to combustibles must be maintained. If running horizontal through an area a 1-1/2" minimum clearance to the top of the horizontal pipe must be maintained.

Maximum vertical height of system should not exceed 43 feet.

Use roof support and rigid pipe at roof level. Flex pipe is not permitted within roof support.

When penetrating the roof a rigid galvanized pipe must be used. Attach flex pipe to the rigid pipe with high temperature sealant, secure with four screws assuring the flex pipe and rigid pipe are secured. Attach rigid pipe to termination with sealant and screw with 4 sheet metal screws. The Inner flex pipe must be secured with 4 screws which must penetrate both the flex pipe and inner section of termination. Attach 7" rigid pipe to 7" termination with sealant and screw with 4 sheet metal screws.

Vertical termination clearance is 18" [45.7cm] above the roof, measured from highest point of exit on the roof line.

Support vertical pipes to maintain minimum of one inch or greater clearances to combustibles.

Roof Flashing

Ensure that you have the proper roof flashing by checking your roof pitch using a level and two rulers, or by using a roof pitch card.

Slide a Roof Flashing suitable to your roof slope over the vent. Place the edge of the flashing plate that will be on the higher part of the roof slope under the shingles. Both the sides and the lower edge lay on top of the shingles.

NOTE: At the top edge of the flashing plate, lift the shingles and nail the plate to the roof deck, then cement the shingles to the plate with a suitable waterproof mastic.

Ensure that the chimney is plumb. Square up the flashing plate and nail in place to the roof deck. Use 12 nails with neoprene washers or cover the heads with a suitable waterproof mastic. Wrap the storm collar around the vent above the flashing. Secure the ends together loosely with nut and bolt supplied. Slide the collar down the vent until it comes in contact with the flashing. Tighten the bolt and seal the Storm Collar to the vent with a suitable waterproof non-combustible mastic.

The flashing and storm collar should be painted to match the roof shingles. This will extend its life and improve the appearance. Clean, prime and paint with suitable painting products.

Vertical Venting in Cold Climates

In cold climate conditions where temperatures go below -10 degrees Celsius or 14 degrees Fahrenheit, we recommend that the chase be insulated and where the vent pipe enters into the attic space that the pipe be wrapped with an insulated Mylar sleeve. This will increase the temperature of the vent and help the appliance to vent properly in cold weather conditions.

It is also important in vertical vented direct vent appliances that the appliance be operated daily during the winter months as this will help stop the termination from freezing up.

We recommend using a thermostat set at room temperature to allow the unit to cycle.

For IPI models it may be necessary to set the appliance to Standing Pilot mode to maintain heat in the cavity. The purpose of this procedure is to prevent cold air from penetrating the chimney and then onto the living space. Therefore, when the internal temperature is slightly elevated the fireplace is able to freely exhaust its combustion and hence making it easier to start up.

-ALSO SEE DIAGRAMS ON FOLLOWING PAGES-

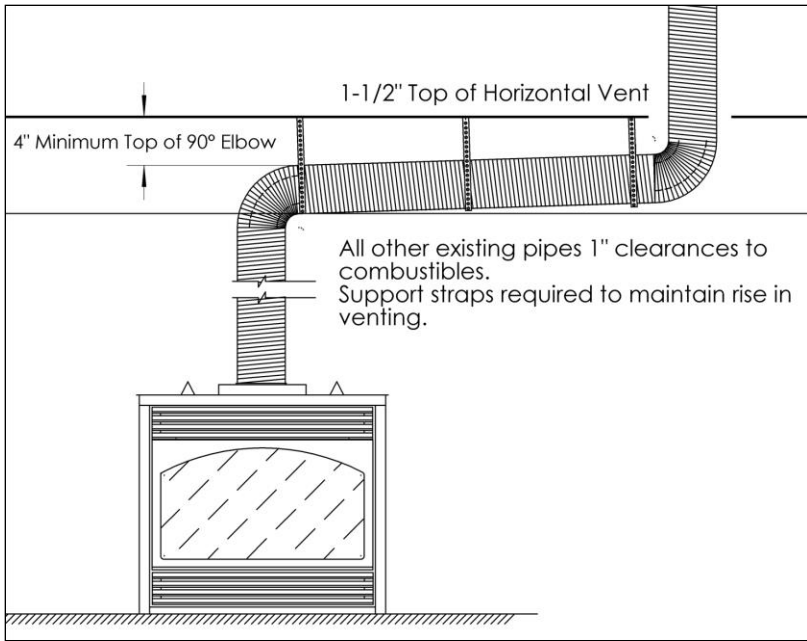

Clearances in horizontal venting.

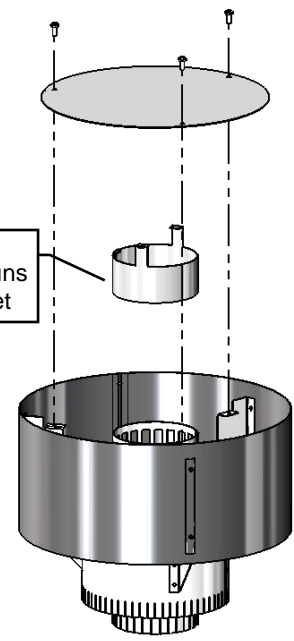

FDVVT40

Clearance to perpendicular wall 24 inches (60 cm). (Recommended to prevent re-circulation of exhaust products. For additional requirements check local codes.)

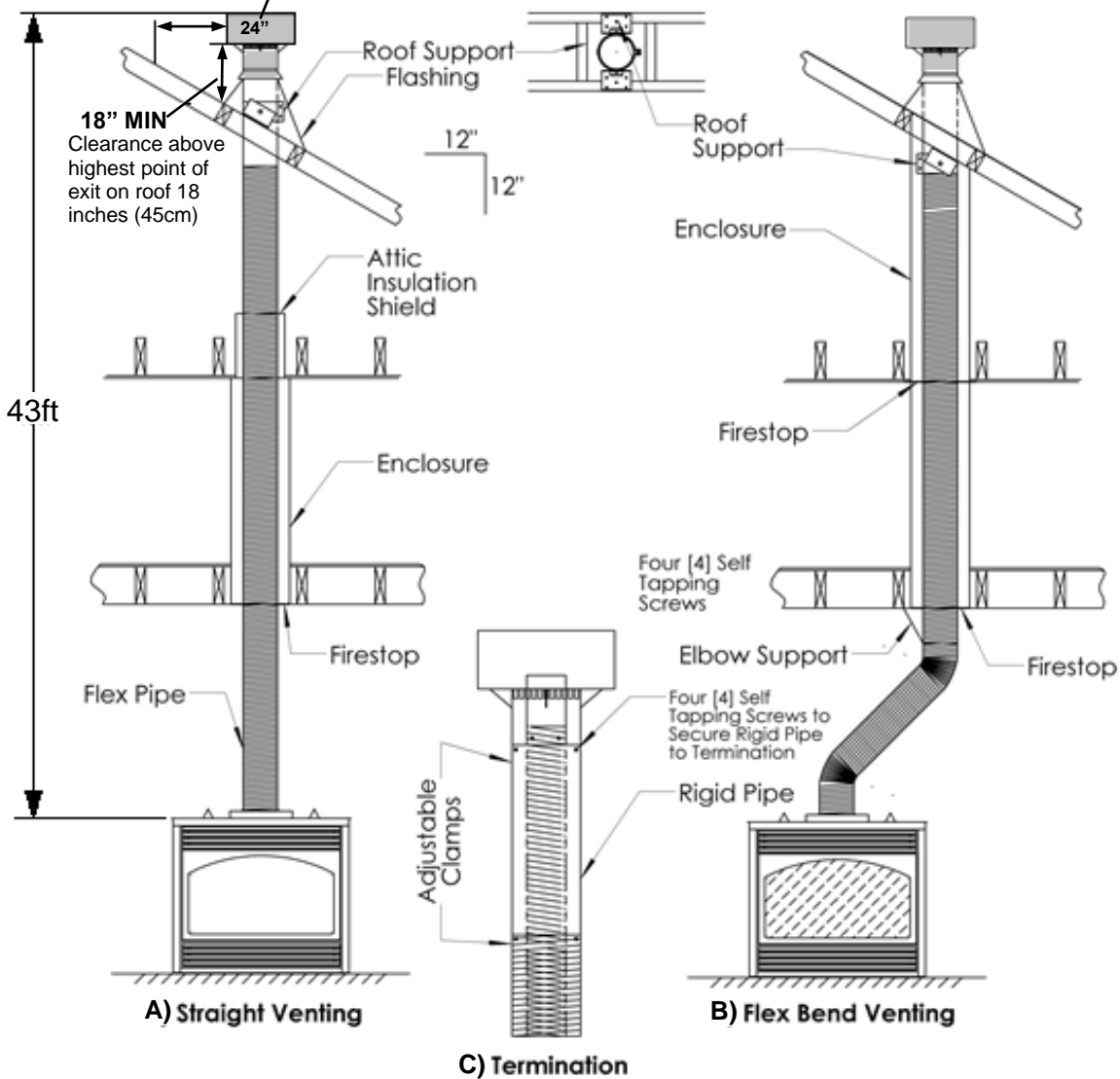

A) Straight-through roof support configuration; B) Flex bend configuration; C) Termination mounting

Fireplace Installations Using Co Linear Flex Kits for Units: HBZDV3624N, HBZDV3624NE, HBZDV3624NE2, HBZDV3624LP, HBZDV3624LPE, HBZDV3624LPE2

⚠ WARNING CO-AXIAL TO CO-LINEAR VENTING CONFIGURATIONS MUST ONLY BE USED IN A NON-COMBUSTIBLE CHIMNEY OR ENCLOSURE. INSTALLATION IN A COMBUSTIBLE ENCLOSURE COULD RESULT IN A FIRE. MINIMUM VENT HEIGHT IS 12 FEET. MAXIMUM VENT HEIGHT IS 43 FEET.

Hard Pipe Adapter	Co Axial to Co Linear Appliance Connector Options	Size of Flex- 3x3 (Min 12ft / Max 43ft)	Termination Options
ZDVDFFA	46DVA-CLAA 46DVA-GCL	IDVFK25 (25ft Kit) ZDV3FC (Flex Connectors)	IDVVT36 (Kingsman)- Requires IDVFK25 (25ft Flex Kit) 46DVA-CL33 High-Wind Termination (c/w35ft of Flex)

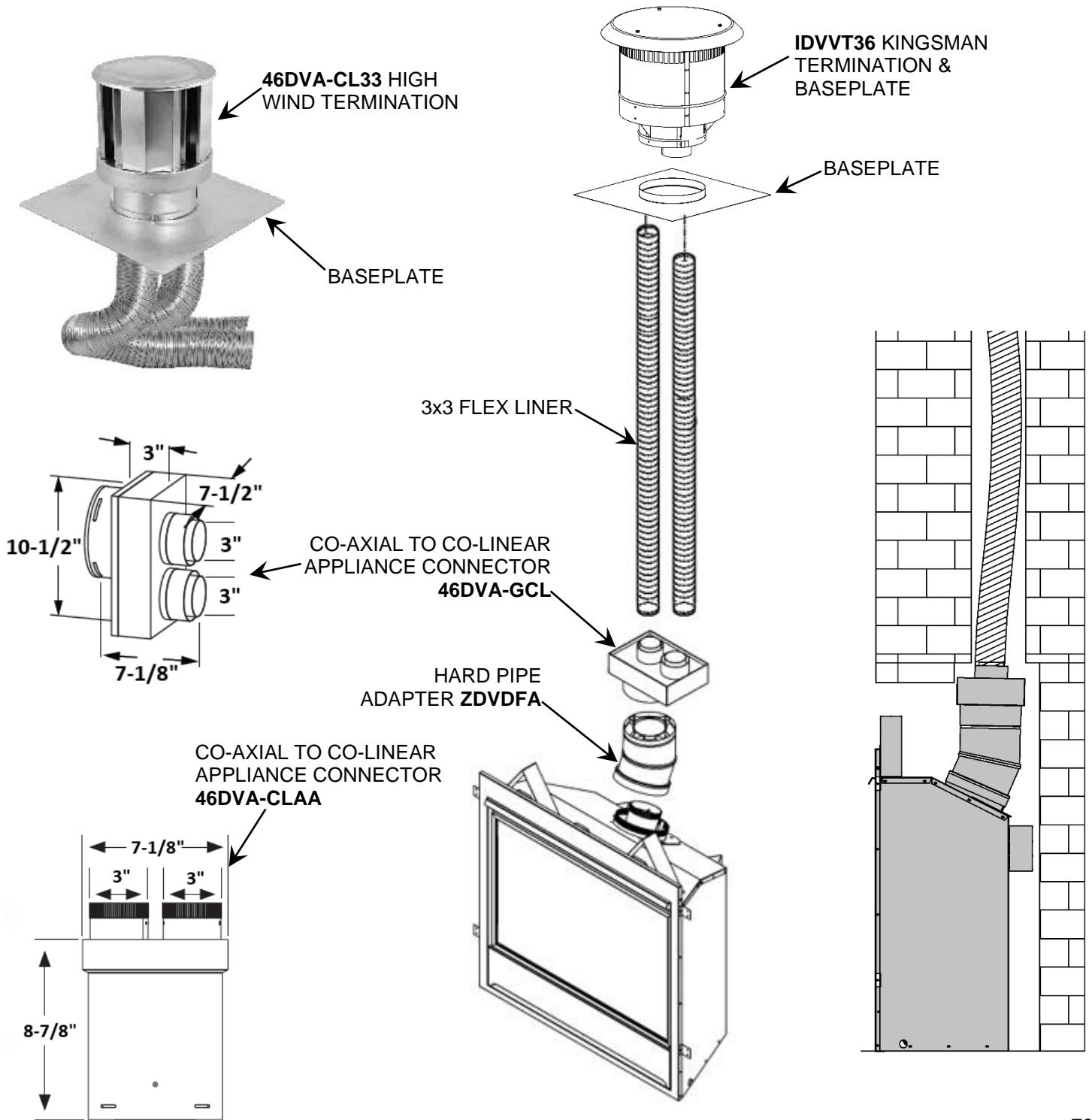

Approved for Power Vent PVH58 / PVH58FM

- This appliance is approved for use with a Kingsman PVH58 Horizontal Power Vent -

A Horizontal Power Vent Termination is intended for use where standard venting configurations are not possible.

NOTE: MODELS EQUIPPED WITH MILLIVOLT/ STANDING PILOT IGNITION: Downward vertical vent runs are **NOT** permitted.

NOTE: MODELS EQUIPPED WITH INTERMITTENT PILOT IGNITION (Proflame 1 or Proflame 2): Downward vertical vent runs are permitted, however, Cold Climate Switch (Standing Pilot Mode) must **NOT** be used.

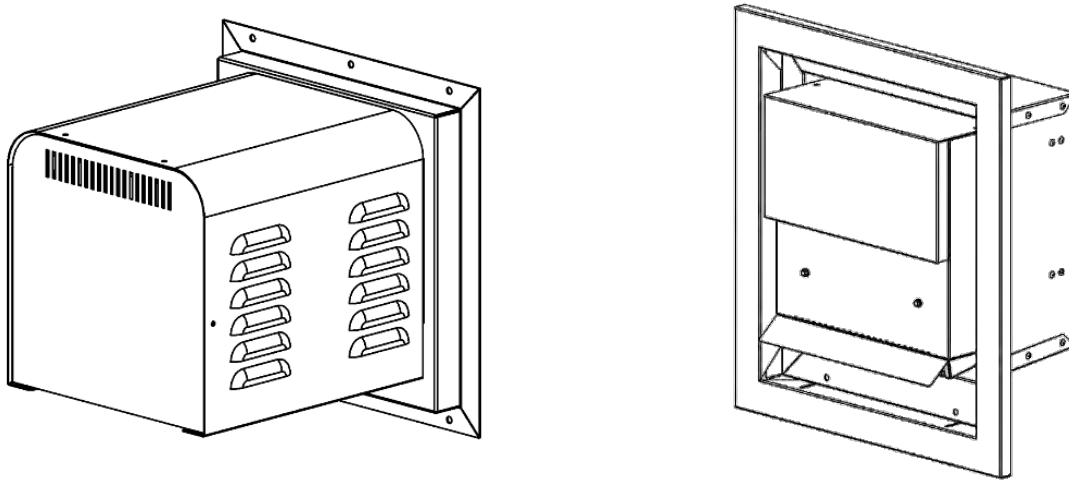

Maximum / Minimum Vent Lengths:

Maximum Vent Length is 125 ft plus six 90° elbows with Air Intake Shutter fully closed. Termination must not be below unit.

This power vent can be installed up to **8ft** below the installed fireplace on runs less than 100ft and not more than four 90° elbows.

Minimum Vent Length is 1 FT vertical x 3 FT horizontal x 3 FT vertical x 3 FT horizontal (See PVH58 manual).

Seven 90° elbows are possible if the total horizontal is not more than 25ft and the vertical does not exceed 15ft.

Refer to Power Vent Manual for proper installation and use.



POWER VENT PARTS LIST – 4/7 VENTING

NUMBER DESCRIPTION

PVH58 Horizontal Power Vent Starter Kit - Exterior Mount

PVH58FM Horizontal Power Vent Kit - Flush Mount

Note: Must use a one-foot section of 5/8 DV hard pipe to connect to the Power Vent Termination (not supplied)

CHOOSE CONTROL MODULE OR HARNESS DEPENDENT ON VALVE SYSTEM

PVC58MV Power Vent Control Module - for Millivolt Models

PVC58IPI Power Vent Control Module - for Proflame 1 - IPI Models

584-X12 Harness for Proflame 2 IPI - Deluxe Models

PVH20H Main Wiring Harness Assembly – Extension Harness (20ft)

CHOOSE VENTING TO BE USED: SECTION 1 - HARD PIPE, SECTION 2 FLEX VENT

SECTION 1 DIRECT VENT HARD PIPE 4x6-5/8" – for entire installation

(Two Adapters needed: one at Flue and one at Termination)

Flue of Fireplace

ZDVDKA Duravent Adapter – for Flat Flue

ZDVDFFA Duravent Adapter – for Sloped Flue

Termination End

ZDVDIA Duravent Hard Pipe Adapter- (used to connect 4x6-/8" to 5/8 Hard Pipe)

Note: Must use a one-foot section of 5/8 DV hard pipe (not supplied) to connect to the Power Vent Termination.

SECTION 2 FLEX VENT - Used for entire installation – order Z47PVA

Note: Must use a one-foot section of 5/8 DV hard pipe connected to the power vent on all installations.

Termination End

Z47PVA Flex Pipe Adapter Kit - (to adapt flex pipe to power vent to hard pipe)

Note: Must use a one-foot section of 5/8 DV hard pipe (not supplied) to connect to the Power Vent Termination.

SECTION 3 DIRECT VENT HARD PIPE 3/5" - for entire installation

(Three Adapters needed two at Flue and one at Termination)

Flue of Fireplace - Choose appropriate adapter for 4x6-5/8"

ZDVDFFA Duravent Fireplace Adapter 4x6-5/8 - Sloped Flue

ZDVDKA Duravent Stove Adapter 4x6-5/8" - Flat (Serene 47)

Convert from 4x6-5/8" to 3/5" MG HP

PVA4635 Duravent Adapter- 4x6-5/8 TO 3/5 - FLUE

Convert to Termination - 3/5" to 5/8"

PVA3558 Duravent Adapter for Power Vent Termination - 3/5" to 5/8"

Note: Must use a one-foot section of 5/8 DV hard pipe to connect to the Power Vent Termination (not supplied)

FLEX VENTING KITS

ZDVFK5 Flex Kit (4" & 7" Dia.) x 2.5' (Unexpanded) 5' Expanded

ZDVFK8 Flex Kit (4" & 7" Dia.) x 8' (c/w Springs, Screws, Mill Pac)

ZDVFK20 Flex Kit (4" & 7" Dia.) x 20' (c/w Springs, Screws, Mill Pac)

POWER VENT ACCESSORIES

ZDV4FC Flex Connector 4" Diameter

ZDV7FC Flex Connector 7" Diameter

ZDV4FCL Flex Clamp 4"

ZDV7FCL Flex Clamp 7"

ZDV4SS Spring 4" Standoff Spacer

PVH58WT Wall Thimble for Power Vent

36HB Parts List

Part Number	Description
-------------	-------------

Fireplaces

HBZDV3624N (Millivolt) HBZDV3624NE (IPI) HBZDV3624NE2 (IPI)	Fireplace Heater rated NG, Tempered Glass, 24,000 BTU with Glowing Ember Bed, bedroom approved
HBZDV3624LP (Millivolt) HBZDV3624LPE (IPI) HBZDV3624LPE2 (IPI)	Fireplace Heater rated LP, Tempered Glass, 22,000 BTU with Glowing Ember Bed, bedroom approved
HBZDV3628N (Millivolt) HBZDV3628NE (IPI) HBZDV3628NE2 (IPI)	Fireplace Heater Rated NG, Ceramic Glass, 28,000 BTU with Glowing Ember Bed BRA-MHA
HBZDV3628LP (Millivolt) HBZDV3628LPE (IPI) HBZDV3628LPE2 (IPI)	Fireplace Heater Rated LP, Ceramic Glass, 26,000 BTU with Glowing Ember Bed BRA-MHA

Fireplace Requirements

Grills or CVCK (clean view circulating kit)(Required for each unit)

HB36CVCK	CVCK(clean view circulating kit) no grill required
----------	--

Grills

HB36GBL	Grill Kit - Black
---------	-------------------

LOG SETS Or ROCK KIT (Required for each unit)

LOGC42	Log Set - 4 pc - Classic Oak (ZDV3320, HB3624/28, HB4224/28 Series)
LOGC43	Log Set - 8 pc - Burnt Oak (ZDV3320, HB3624/28, HB4224/28 Series)
LOGC44	Log Set - 8 pc - Burnt Oak (ZDV3320,
MQLOGC45	Oak Log Set – 7 pc
MQROCK1	Rock Set - Tan
MQROCK2	Rock Set – Grey
MQROCK3	Rock Set – Multi Color
MQRSP3	Rock Platform and screws (HBZDV 3624, 3628, 4224, 4228)

Fireplace Surrounds

HB36SBL	Surround – Black (Coverage 35 1/2" H x 41 1/8"W)
---------	--

Accessories

Z36FK	Fan Kit w/Variable Speed Wall Mount Control (Temperature Sensing)
Z2MT	Thermostat Millivolt Wall Mount
Z80PT	Thermostat Programmable Digital Millivolt Wall Mount (1F80-40)
DCHS	Remote Control Heatshield
HB36RLC	Refractory Liner Classic
HB36RLT	Refractory Liner Traditional
HB36RLH	Refractory Liner Herring Bone

Replacement Burner Assembly

3624HB-BNGSI	Burner Assembly - Natural Gas c/w Valve System (HBZDV3624N)
3624HB-BLPSI	Burner Assembly - Liquid Propane c/w Valve System (HBZDV3624LP)

3628HB-BNGSI	Burner Assembly - Natural Gas c/w Valve System (HBZDV3628N)
--------------	---

3628HB-BLPSI	Burner Assembly - Liquid Propane c/w Valve System (HBZDV3628LP)
--------------	---

Valve Systems

1001-P633SI	SIT Millivolt Valve Nova LP Hi/Lo
1003-P651SI	SIT Millivolt Valve Nova LP Hi/Lo
1001-P634SI	SIT Millivolt Valve Nova NG Hi/Lo
1003-P652SI	SIT Millivolt Valve Nova NG Hi/Lo
1006-P003SI	SIT Proflame 1 Valve Nova LP Hi/Lo
1006-P002SI	SIT Proflame 1 Valve Nova NG Hi/Lo
1005-P002SI	SIT Proflame 2 Valve Nova LP
1005-P001SI	SIT Proflame 2 Valve Nova NG

Pilot Assemblies

1001-P713SI	SIT Millivolt Pilot Assembly LP
1001-P714SI	SIT Millivolt Pilot Assembly NG
1002-P047SI	SIT IPI Pilot Assembly LP
1002-P033SI	SIT IPI Pilot Assembly NG

Valve System Parts - New Top convertible SIT (Millivolt)

1000-P136WR	Thermopile GOAI-524
1001-P069SI	Electrode Sparker 915.069 TC SIT
1001-P216SI	Thermocouple 290.216 TC SIT
1001-P165SI	Orifice Pilot NG 977.165 TC SIT
1001-P167SI	Orifice Pilot LP 977.167 TC SIT

Electronic Ignition/Remote Control IPI

EGTRC	Remote Control IPI (Thermostat)
EGTMRCN	Remote Control IPI (Thermostat/Modulating - NG)
EGTMRCP	Remote Control IPI (Thermostat/Modulating - LP)
EGTFRCN	Remote Control IPI (Thermostat/Modulating/Fan - NG)
EGTFRCP	Remote Control IPI (Thermostat/Modulating/Fan - LP)

Electronic Ignition Replacement Parts IPI

1006-P002si	Valve IPI (NG; Hi/Lo)
1006-P003si	Valve IPI (LP; Hi/Lo)
1002-P047si	Pilot Assembly (LP)
1002-P033si	Pilot Assembly (NG)
1002-P089si	Spark Electrode (Long)
1002-P113si	Electrode Flame Sensor (Long)
1002-P302si	IPI Ignition Board
1002-P850si	AC Wall Adapter
1002-P12BH	Battery Pack
1002-P912si	Wiring Harness
1002-P166si	Orifice Pilot (NG #62)
1002-P168si	Orifice Pilot (LP #35)
1002-P013si	Stepper Motor (NG)
1002-P012si	Stepper Motor (LP)
1002-P016is	Hi/Lo Regulator (NG)
1002-P014si	Hi/Lo Regulator (LP)

Miscellaneous Parts

1000-150GE	#Silicone GE Red IS806 #736
1000-150MP	#Hi-Temp Mill Pac Sealant 840099
1000-214	#Piezo-Igniter 1244-17 MARK 21
1000-215	#Pal Nut (18MMX1.5MM) Blk (1364.03)
1000-218	#Switch Ivory (1451/001)
1000-227	#Cover Ivory (86001/001)
1000-255	#Orifice Brass - (State Size)
1000-EMBER	#Moon Rock
2000-080	#Thermodisc 2450 (For Blower)
2000-081	#Blower Motor QLN65/2400
1000-085	#Control Variable Speed KBWC-13BV
1000-306	Thermalcord - Adhesive Back for Door Frame
36HB-310	Ceramic Glass - For All HBZDV3600
36HB-311	Tempered Glass - For HBZDV3624 Model
HB36CSS	Replacement Safety Screen
36HB-123	Upper Door Spring

Conversion Kit (Sit Valve Only) (Millivolt)

3624HB-CKLP	LP Conversion Kit for HBZDV3624 (Millivolt)
3624HB-CKNG	NG Conversion Kit for HBZDV3624 (Millivolt)
3628HB-CKLP	LP Conversion Kit for HBZDV3628 (Millivolt)
3628HB-CKNG	NG Conversion Kit for HBZDV3628 (Millivolt)

Conversion Kit (Sit Valve Only) (IPI)

3624HB-CKLPI	LP Conversion Kit for HBZDV3624 (IPI)
3624HB-CKNGI	NG Conversion Kit for HBZDV3624 (IPI)
3628HB-CKLPI	LP Conversion Kit for HBZDV3628 (IPI)
3628HB-CKNGI	NG Conversion Kit for HBZDV3628 (IPI)

Kingsman Fireplace Venting

Catalog Number	Description
ZDVHSK	Horizontal Vent Starter Kit - 3 FT Length Horizontal Vent Termination, Wall Thimble, 36" Flex Pipe, Mill Pac, screws/washers, springs.
ZDVHSK5	Horizontal Vent Starter Kit - 5 FT Length Horizontal Vent Termination, Wall Thimble, 60" Flex Pipe, Mill Pac, screws/washers, springs.
ZDVHKSQ	Horizontal Square Termination Vent Starter Kit -3 FT Length Horizontal Vent Termination, Wall Thimble, Wall Thimble, 36" Flex Pipe, Mill Pac
ZDVHKSQ5	Horizontal Square Termination Vent Starter Kit -5 FT Length Horizontal Vent Termination, Wall Thimble, Wall Thimble, 60" Flex Pipe, Mill Pac
ZDVDKA	Duravent Fireplace Adapter
FDVVT40	Vertical Vent Termination
FDVHT	Horizontal Vent Termination
FDVHSQ	Horizontal Square Termination

Z47ST24	Horizontal Snorkel Termination (24" Tall, 14-1/2" Center to Center)
Z47ST36	Horizontal Snorkel Termination (36" Tall, 26-1/2" Center to Center)
Z57STSC	Safety Cage for Horizontal Snorkel Termination
FDVHSCU	Safety Cage for Horizontal Termination
ZDVAIS	Attic Insulation Shield
Z7AIS24	Attic Insulation Shield 24"
ZDVVOS	Offset Support
ZDVFS	Firestop Spacer
ZDVRS	Roof Support
ZDVWT	Wall Thimble (Horizontal Venting)
ZDVSS	Siding Shield for FDVHT
ZDVSSLR	Siding Shield - Large Return
ZDV48GP	Galvanized Pipe 7" Dia. x 48" (Vertical Installations)
ZDVAAF	Flashing 7" c/w Storm Collar (1/12 to 7/12)
ZDVAF2	Flashing 7" c/w Storm Collar (8/12 to 12/12)
ZDVAF3	Flashing 7" c/w Storm Collar Flat
ZDV7SC	Storm Collar 7"
ZDVFK5	Flex Kit (4" & 7" Dia.) x 2.5' (Unexpanded) 5' Expanded
ZDVFK8	Flex Kit (4" & 7" Dia.) x 4' (Unexpanded) 8' Expanded
ZDVFK20	Flex Kit (4" & 7" Dia.) x 10' (Unexpanded) 20' Expanded *Kits are complete with spring stand-offs & silicone.
ZDV4FC	Flex Connector 4" Diameter
ZDV7FC	Flex Connector 7" Diameter
ZDV4SS	Spring 4" Standoff Spacer

MQHBZDV3636 Parts List

Part Number	Description
Fireplace Part Numbers	
MQHBZDV3636N (Millivolt)	Fireplace Heater Rated NG, Ceramic Glass, 30,500 BTU AT 75% efficient. Approved for bedroom and mobile home.
MQHBZDV3636NE (IPI)	
MQHBZDV3636NE2 (IPI) (c/w Remote Control)	
MQHBZDV3636LP (Millivolt)	Fireplace Heater Rated LP, Ceramic Glass, 29,200 BTU AT 75% efficient. Approved for bedroom and mobile home.
MQHBZDV3636LPE (IPI)	
MQHBZDV3636LPE2 (IPI) (c/w Remote Control)	

Fireplace Requirements

Grills - OR - CVCK (clean view circulating kit) Required for each unit

HB36CVCK	CVCK (clean view circulating kit) no grill required
HB36GBL	Grill Kit - Black

LOG SETS/ROCK KITS: (Required for each unit)

LOGF36	Log Set - 7 pc. - Split Oak
MQROCK1	Rock Set - Tan
MQROCK2	Rock Set - Grey
MQROCK3	Rock Set - Multi Color
MQRSP2	Rock Platform, Support, and 4 Screws (MQHBZDV3636, 4236)

Fireplace Surrounds - Optional

HB36SBL	Surround – Black (Coverage 35 1/2" H x 41 1/8"W)
---------	---

Refractory Liners

HB36PL	Porcelain Reflective Liner
HB36RLC	Refractory Liner Classic
HB36RLT	Refractory Liner Traditional
HB36RLH	Refractory Liner Herring Bone

Safety Screens

HB36CSS	Safety Screen Replacement
---------	---------------------------

Optional Fan Kit / Blower

Z36FK	Fan Kit w/Variable Speed Wall Mount Control (Temperature Sensing)
-------	---

Replacement Burner Assembly

3636MQ-BNGSI	Burner Assembly - Natural Gas c/w Valve System (HBZDV3636N)
3636MQ-BLPSI	Burner Assembly - Natural Gas c/w Valve System (HBZDV3636LP)

Conversion Kit (Sit Valve Only)

3632HB-CKLP	LP Conversion Kit for HBZDV3632/3636 (Millivolt)
3632HB-CKNG	NG Conversion Kit for HBZDV3632/3636 (Millivolt)
3632HB-CKLPI	LP Conversion Kit for HBZDV3632/3636 (Proflame 1 IPI)
3632HB-CKNGI	NG Conversion Kit for HBZDV3632/3636 (Proflame 1 IPI)
3632HB –CKLP2	LP Conversion Kit for HBZDV3632/3636 (Proflame 2 IPI)
3632HB –CKNG2	NG Conversion Kit for HBZDV3632/3636 (Proflame 2 IPI)

Valve Systems

1001-P633SI	SIT Millivolt Valve Nova LP Hi/Lo
1003-P651SI	SIT Millivolt Valve Nova LP Hi/Lo
1001-P634SI	SIT Millivolt Valve Nova NG Hi/Lo
1003-P652SI	SIT Millivolt Valve Nova NG Hi/Lo
1006-P003SI	SIT Proflame 1 Valve Nova LP Hi/Lo
1006-P002SI	SIT Proflame 1 Valve Nova NG Hi/Lo
1005-P002SI	SIT Proflame 2 Valve Nova LP
1005-P001SI	SIT Proflame 2 Valve Nova NG

Pilot Assemblies

1001-P713SI	SIT Millivolt Pilot Assembly LP
1001-P714SI	SIT Millivolt Pilot Assembly NG
1002-P047SI	SIT IPI Pilot Assembly LP
1002-P033SI	SIT IPI Pilot Assembly NG

Valve System Parts - Top convertible SIT (Millivolt)

1000-P136WR	Generator / Thermopile
1001-P069SI	Electrode Sparker 915.069 TC SIT
1001-P216SI	Thermocouple 290.216 TC SIT
1001-P165SI	Orifice Pilot NG 977.165 TC SIT
1001-P167SI	Orifice Pilot LP 977.167 TC SIT

Optional Thermostats and Remote Controls

Z2MT	Thermostat Digital - Vertical Wall Mount - MV/PF1
Z80PT	Thermostat Programmable Digital - Wall Mount - MV/PF1
GFRC	Remote Control Millivolt / IPI – On/Off
GTRC	Remote Control Millivolt - Thermostat
GTMRCN	Remote Control Millivolt – Thermostat/Modulating - NG
GTMRCP	Remote Control Millivolt – Thermostat/Modulating - LP
GTFRCN	Remote Control Millivolt – Thermostat/Modulating/Fan - NG
GTFRCP	Remote Control Millivolt – Thermostat/Modulating/Fan - LP
EGTRC	Remote Control IPI PF1- Thermostat
EGTMRCN	Remote Control IPI PF1- Thermostat/Modulating - NG
EGTMRCP	Remote Control IPI PF1- Thermostat/Modulating - LP
EGTFRCN	Remote Control IPI PF1- Thermostat/Modulating/Fan - NG
EGTFRCP	Remote Control IPI PF1 - Thermostat/Modulating/Fan - LP

Electronic Ignition Replacement Parts IPI

1006-P002si	Valve IPI (NG; Hi/Lo)
1006-P003si	Valve IPI (LP; Hi/Lo)
1002-P047si	Pilot Assembly (LP)
1002-P033si	Pilot Assembly (NG)
1002-P089si	Spark Electrode (Long)
1002-P113si	Electrode Flame Sensor (Long)
1002-P302si	IPI Ignition Board
1002-P850si	AC Wall Adapter
1002-P12BH	Battery Pack
1002-P912si	Wiring Harness

1001-P166si	Orifice Pilot (NG)
1001-P168si	Orifice Pilot (LP)
1002-P013si	Stepper Motor (NG)
1002-P012si	Stepper Motor (LP)
1002-P016si	Hi/Lo Regulator (NG)
1002-P014si	Hi/Lo Regulator (LP)

Miscellaneous Parts	
1000-150GE	Silicone GE Red IS806 #736
1000-150MP	Hi-Temp Millpac Sealant 840099
1000-214	Piezo-Igniter 1244-17 MARK 21
1000-215	Pal Nut (18MMX1.5MM)BLK (1364.03)
1000-218	Switch Ivory (1451/001)
1000-227	Cover Ivory (86001/001)
1000-255	Orifice Brass - (State Size)
2000-080	Thermodisc 2450 (For Blower)
1000-306	Thermalcord - Adhesive Back for Door Frame
1000-085	Control Variable Speed KBWC-13BV
FP15GC	Stainless Steel Gas Connector
VLBIT4	Log Bits - Large Four Piece Kit
VLBIT6	Log Bits - Small Six Piece Kit
1000-EMBER	Moon Rock
2000-081	Blower Motor QLN65/2400
36HB-310	Ceramic Glass - For All HBZDV3600
36HB-123	Upper Door Spring

Kingsman Fireplace Venting

Catalog Number	Description
ZDVHSK	Horizontal Vent Starter Kit - 3 FT Length Horizontal Vent Termination, Wall Thimble, 36" Flex Pipe, Mill Pac, screws/washers, springs.
ZDVHSK5	Horizontal Vent Starter Kit - 5 FT Length Horizontal Vent Termination, Wall Thimble, 60" Flex Pipe, Mill Pac, screws/washers, springs.
ZDVHKSQ	Horizontal Square Termination Vent Starter Kit -3 FT Length Horizontal Vent Termination, Wall Thimble, Wall Thimble, 36" Flex Pipe, Mill Pac
ZDVHKSQ5	Horizontal Square Termination Vent Starter Kit -5 FT Length Horizontal Vent Termination, Wall Thimble, Wall Thimble, 60" Flex Pipe, Mill Pac
ZDVDKA	Duravent Fireplace Adapter
FDVVT40	Vertical Vent Termination
FDVHT	Horizontal Vent Termination
FDVHSQ	Horizontal Square Termination
Z47ST24	Horizontal Snorkel Termination (24" Tall, 14-1/2" Center to Center)
Z47ST36	Horizontal Snorkel Termination (36" Tall, 26-1/2" Center to Center)
Z57STSC	Safety Cage for Horizontal Snorkel Termination
FDVHSCU	Safety Cage for Horizontal Termination
ZDVAIS	Attic Insulation Shield

Z7AIS24	Attic Insulation Shield 24"
ZDVVOS	Offset Support
ZDVFS	Firestop Spacer
ZDVRS	Roof Support
ZDVWT	Wall Thimble (Horizontal Venting)
ZDVSS	Siding Shield for FDVHT
ZDVSSLR	Siding Shield - Large Return
ZDV48GP	Galvanized Pipe 7" Dia. x 48" (Vertical Installations)
ZDVAAF	Flashing 7" c/w Storm Collar (1/12 to 7/12)
ZDVAF2	Flashing 7" c/w Storm Collar (8/12 to 12/12)
ZDVAF3	Flashing 7" c/w Storm Collar Flat
ZDV7SC	Storm Collar 7"
ZDVFK5	Flex Kit (4" & 7" Dia.) x 2.5' (Unexpanded) 5' Expanded
ZDVFK8	Flex Kit (4" & 7" Dia.) x 4' (Unexpanded) 8' Expanded
ZDVFK20	Flex Kit (4" & 7" Dia.) x 10' (Unexpanded) 20' Expanded *Kits are complete with spring stand-offs & silicone.
ZDV4FC	Flex Connector 4" Diameter
ZDV7FC	Flex Connector 7" Diameter
ZDV4SS	Spring 4" Standoff Spacer



LIMITED LIFETIME WARRANTY

This Limited Lifetime Warranty applies only while the unit remains at the site of the original installation and only if the unit is installed inside the continental United States, Alaska, Hawaii, and Canada. The warranty applies only if the unit is installed and operated in accordance with the printed instructions and in compliance with applicable installation and building codes and good trade practices.

BASIC ONE YEAR WARRANTY

During the first year after installation of the appliance, we will provide a replacement for any component part of your unit found to be defective in materials or workmanship, including labour costs. Repair work requires prior approval by Kingsman, labour costs are based on a predetermined rate schedule and any repair work must be done through an authorized Kingsman dealer.

(Excluded Components: Accent Light Bulbs, Gasketing and Paint)

LIMITED LIFETIME WARRANTY

The heat exchanger, combustion chamber and burner of every Kingsman product excluding the Outdoor Firepit are warranted against materials or workmanship during the period the product is owned by the original owner. The part to be replaced must be returned to our distributor in exchange for the replacement part. Any labor, material, freight and/or handling charges associated with any repair or replacement pursuant to this Limited Lifetime Warranty will not be covered by this warranty.

GENERAL TERMS

In lieu of providing a replacement part, we may, at our option, provide the distributor's component purchase price from us or a credit equal to the distributor's component purchase price from us toward the purchase of any new unit which we distribute. If a credit is given in lieu of a replacement part, the rating plate from the unit being replaced must be submitted on a warranty claim, and the unit being replaced must be made available to our distributor for disposition.

In establishing the date of installation for any purpose, including determination of the starting date for the term of this Limited Lifetime Warranty, reasonable proof of the original installation date must be presented*, otherwise the effective date will be based upon the date of manufacture plus thirty (30) days.

We will not be responsible for and you, the user, will pay for: (a) damages caused by accident, abuse, negligence, misuse, riot, fire, flood, or Acts of God (b) damages caused by operating the unit where there is a corrosive atmosphere containing chlorine, fluorine, or any other damaging chemicals (other than in a normal residential environment) (c) damages caused by any unauthorized alteration or repair of the unit affecting its stability or performance (d) damages caused by improper matching or application of the unit or the unit's components (e) damages caused by failing to provide proper maintenance and service to the unit (f) any expenses incurred for erecting, disconnecting or dismantling the unit (g) parts or supplies used in connection with service or maintenance (h) damage repairs, inoperation or inefficiency resulting from faulty installation or application (i) electricity or fuel costs or any increase in electricity or fuel cost whatsoever including additional or unusual use of supplemental electric heat.

We shall not be liable for any incidental, consequential, or special damages or expenses in connection with any use or failure of this unit. We have not made and do not make any representation or warranty of fitness for a particular use or purpose, and there is no implied condition of fitness for a particular use or purpose. We make no express warranties except as stated in this Limited Lifetime Warranty. No one is authorized to change this Limited Lifetime Warranty or to create for us any other obligation or liability in connections with this unit. Any implied warranties shall last for one year after the original installation. Some states and provinces do not allow the exclusion or limitation of incidental or consequential damages or do not allow limitations on how long an implied warranty or condition lasts, so the above limitations or exclusions may not apply to you. The provisions of this limited warranty are in additions to and not a modification of or subtraction from any statutory warranties and other rights and remedies provided by law.

Save this certificate. It gives you specific legal rights, and you may also have other rights which may vary from state to state and province to province.

In the event your unit needs servicing, contact your dealer or contractor who installed or serviced your unit. When requesting service, please have the model and serial number from each unit readily available. If your dealer needs assistance, the distributor is available for support and we, in turn support the distributor's efforts.

Fill in the installation date and model and serial numbers of the unit in the space provided below and retain this limited warranty for your files.

Model No. _____ Serial No. _____ Date installed _____

Dealer or Contractor Name: _____

*To receive advantage of your warranty, you must retain the original records that can establish the installation date of your unit.