

Installation and Operation Manual

CHASKA-34 ROCK

Model #CSK-34-R

Direct Vent Gas Fireplace Insert

▲ WARNING:

FIRE OR EXPLOSION HAZARD

Failure to follow safety warnings exactly could result in serious injury, death, or property damage.

- Do not store or use gasoline or other flammable vapors and liquids in the vicinity of this or any other appliance.
- **WHAT TO DO IF YOU SMELL GAS**
 - Do not try to light any appliance.
 - Do not touch any electrical switch; do not use any phone in your building.
 - Leave the building immediately.
 - Immediately call your gas supplier from a neighbor's phone. Follow the gas supplier's instructions.
 - If you cannot reach your gas supplier, call the fire department.
- Installation and service must be performed by a qualified installer, service agency or the gas supplier.



DANGER



**HOT GLASS WILL
CAUSE BURNS**

**DO NOT TOUCH GLASS
UNTIL COOLED**

**NEVER ALLOW CHILDREN
TO TOUCH GLASS**

A barrier designed to reduce the risk of burns from the hot viewing glass is provided with this appliance and shall be installed for the protection of children and other at-risk individuals.

This appliance may be installed in an aftermarket, permanently located, manufactured home (USA only) or mobile home, where not prohibited by local codes.

This appliance is only for use with the type of gas indicated on the rating plate. This appliance is not convertible for use with other gases, unless a certified kit is used.

English and French installation manuals are available through your local dealer. Visit our website www.kozyheat.com or scan the QR code for our mobile app.

Les manuels d'installation en français et en anglais sont disponibles chez votre détaillant local. Visitez www.kozyheat.com ou scannez ce code QR pour notre application mobile.



**INSTALLER: Leave this manual with the appliance.
CONSUMER: Retain this manual for future reference.**

Read this manual before installation or operating this appliance.
Please retain this owner's manual for future reference.

CONGRATULATIONS!

We welcome you as a new owner of a Kozy Heat gas fireplace. Kozy Heat products are designed with superior components and materials, and assembled by trained craftsmen who take pride in their work. To ensure you receive a quality product, the burner and valve assembly are 100 percent test-fired, and the complete fireplace is thoroughly inspected before packaging. Our commitment to quality and customer satisfaction has remained the same for over 30 years. We offer a complete line of gas and wood fireplaces, along with stylish accessories to complement any decor. Adding a fireplace is one of the best ways to increase the value of your home, and we are proud to offer a network of dealers throughout the country to help make your experience everything you imagine. We pride ourselves in being dedicated not only to functionality and reliability, but also customer safety. We offer our continual support and guidance to help you achieve the maximum benefit and enjoyment from your Kozy Heat gas fireplace.

Jim Hussong
President



Dudley Hussong
Board Chairman



Homeowner Reference Information

We recommend you record the following information:

Model Name: _____ Date purchased/installed: _____

Serial Number: _____ Location of fireplace: _____

Dealership Purchased from: _____ Dealer phone: _____

Notes: _____

TABLE OF CONTENTS

TABLE OF CONTENTS	5	8.0 FACING AND FINISHING	18
1.0 INTRODUCTION	6	8.1 Clearances to Combustibles	18
1.1 Appliance Certification.....	6	8.2 Shroud Installation.....	19
1.2 Requirements for the Commonwealth of Massachusetts	6	8.3 Safety Barrier Installations.....	19
2.0 SPECIFICATIONS	7	9.0 FIREPLACE INSERT SETUP	20
2.1 Appliance Components	7	9.1 Glass Assembly.....	20
2.2 Heating Specifications.....	7	9.2 Light Kit.....	20
2.3 Appliance Dimensions	8	9.3 #CK34-R500 Rock Kit Installation	21
2.4 Part Assembly Overview.....	9	9.4 Control Board Removal and Installation.....	22
2.5 Safety Barriers.....	10	10.0 ELECTRICAL INFORMATION	23
3.0 EXISTING FIREPLACE REQUIREMENTS	11	10.1 Electrical Specifications.....	23
3.1 Appliance Placement Considerations.....	11	10.2 Wiring Requirements.....	23
3.2 Existing Fireplace Specifications	11	11.0 OPERATING INSTRUCTIONS	24
4.0 TERMINATION LOCATION	12	11.1 Initialize the Control System	25
4.1 Vent Termination Clearances.....	12	11.2 Backup Battery Operation	25
5.0 INSTALLATION PREPARATION	13	11.3 IFC Module Ignition Sequence	25
5.1 Inspect and Clean Existing Chimney	13	11.4 Reset the System for Manual Operation.....	25
5.2 Flue Damper	13	11.5 Remote Control Operation	26
5.3 Gas Line.....	13	12.0 ADJUSTMENT	29
5.4 Electrical Wiring	13	12.1 Pressure Testing	29
5.5 Fireplace Conversion	13	12.2 Flame Appearance Adjustments.....	30
6.0 INSTALLATION	14	13.0 TROUBLESHOOTING	31
6.1 Kozy Heat #816-CL Co-Linear Vent System.....	14	14.0 MAINTENANCE	33
6.2 Fireplace Insert Air Duct Removal.....	15	14.1 Burner and Pilot System	33
6.3 Run Vent System.....	15	14.2 Fans.....	33
6.4 Connect Vent Pipe to Air Duct	16	14.3 Vent System.....	33
6.5 Place and Secure Appliance.....	16	14.4 Glass Assembly	33
7.0 GAS LINE CONNECTION	17	15.0 REPLACEMENT PARTS LIST	34
7.1 Gas Conversion (sold separately)	17	LIMITED WARRANTY	35
7.2 Gas Line Installation	17	LIFETIME WARRANTY	37

1.0 INTRODUCTION

1.1 Appliance Certification

Laboratory: OMNI-Test Laboratories in Portland, Oregon

Standards:

- ANSI Z21.88-2014/CSA 2.33-2014, *Vented Gas Fireplace Heaters*
- CGA 2.17-M91 (R2009), *Gas-Fired Appliances for Use at High Altitudes*
- CSA P.4.1-2009, *Testing Method for Measuring Annual Fireplace Efficiency*

This installation must conform with local codes, or in the absence of local codes, with the *National Fuel Gas Code*, ANSI Z223.1/NFPA 54, or the *Natural Gas and Propane Installation Code*, CSA B149.1.

1.2 Requirements for the Commonwealth of Massachusetts

The following requirements reference various Massachusetts and national codes not contained in this manual.

For all sidewall horizontally vented gas fueled equipment installed in every dwelling, building or structure used in whole or in part for residential purposes, including those owned or operated by the Commonwealth and where the side wall exhaust vent termination is less than (7) feet above finished grade in the area of the venting, including but not limited to decks and porches, the following requirements shall be satisfied:

1.2.1 Installation of Carbon Monoxide Detectors

At time of installation of side wall horizontally vented gas fueled equipment, the installing plumber or gas-fitter shall observe that a hard wired carbon monoxide detector with an alarm and battery back-up is installed on the floor level where the gas equipment is to be installed. In addition, the installing plumber or gas-fitter shall observe that a battery operated or hard wired carbon monoxide detector is installed on each additional level of the dwelling, building or structure served by the side wall horizontal vented gas fueled equipment. It shall be the responsibility of the property owner to secure the services of qualified licensed professionals for the installation of hard wired carbon monoxide detectors.

In the event that the side wall horizontally vented gas fueled equipment is installed in a crawl space or attic, the hard wired carbon monoxide detector with alarm and battery back-up may be installed on the next adjacent floor level. In the event that the requirements of this subdivision can not be met at the time of completion of installation, the owner shall have a period of thirty (30) days to comply with the above requirements; provided, however, that during said thirty (30) day period, a battery operated carbon monoxide detector with an alarm shall be installed.

1.2.2 Approved Carbon Monoxide Detectors

Each carbon monoxide detector as required in accordance with the above provisions shall comply with NFPA 720 and be ANSI/UL 2034 listed and IAS certified.

1.2.3 Signage

A metal or plastic identification plate shall be permanently mounted to the exterior of the building at a minimum of eight (8) feet above grade directly in line with the exhaust vent terminal for the horizontally vented gas fueled heating appliance or equipment. The

sign shall read, in print no less the one-half inch (1/2) in size, "GAS VENT DIRECTLY BELOW. KEEP CLEAR OF ALL OBSTRUCTIONS".

1.2.4 Inspection

The state or local gas inspector of the side wall horizontally vented gas fueled equipment shall not approve the installation unless, upon inspection, the inspector observes carbon monoxide detectors and signage installed in accordance with the provisions of 248 CMR 5.08 (2) (a) 1 through 4.

1.2.5 Exemptions

The following equipment is exempt from 248 CMR 5.08 (2) (a) 1 through 4: The equipment listed in Chapter 10 entitled "Equipment Not Required To Be Vented" in the most current edition of NFPA 54 as adopted by the Board; and Product Approved side wall horizontally vented gas fueled equipment installed in a room or structure separate from the dwelling, building or structure used in whole or in part for residential purposes.

1.2.6 Manufacturer Requirements

1.2.6.1 Gas Equipment Venting System Provided

When the manufacturer of Product Approved side wall horizontally vented gas equipment provides a venting system design or venting system components with the equipment, the instructions provided by the manufacturer for installation of the equipment and the venting system shall include:

- Detailed instructions for the installation of the venting system design or the venting system components; and
- A complete parts list for the venting system design or venting system.

1.2.6.2 Gas Equipment Venting System NOT Provided

When the manufacturer of Product Approved side wall horizontally vented gas equipment does not provide the parts for venting the flue gases, but identifies "special venting systems", the following requirements shall be satisfied by the manufacturer:

- The referenced "special venting systems" instructions shall be included with the appliance or equipment installation instructions and;
- The "special venting systems" shall be Product Approved by the Board, and the instructions for that system shall include a parts list and detailed installation instructions.

A copy of all installation instructions for all Product Approved side wall horizontally vented gas fueled equipment, all venting instructions, all parts lists for venting instructions, and/or all venting design instructions shall remain with the appliance or equipment at the completion of the installation.

2.0 SPECIFICATIONS

2.1 Appliance Components

Part Number	Description
CK34L-150	Control Board Assembly
700-203	Manual Gas Shut-off Valve
CK34L-135	Burner Assembly
CK34-R500	Rock Kit
700-001T	Glass Assembly
CK34-075	Fan Kit (1)-75 CFM
500-CK34	Grill Assembly
700-408	Remote Control

2.1.1 Additional Components Required

2.1.1.1 Shrouds

Part Number	Description
CK34-2740	27" x 40" shroud (1 pc.)
CK34-3044	30" x 44" shroud (1 pc.)
CK34-3346	33" x 46" shroud (1 pc.)
CK34-A3444	34" x 44" shroud (1 pc.)
CK34-CUS	Custom Shroud
CK34-ACUS	Arched Custom Shroud

2.1.1.2 Approved Vent Systems

Kozy Heat #816-CL co-linear vent system

For use with minimum 6" x 8" I.D. masonry or 7" I.D. Class A metal chimneys; includes 12 ft. (3.66 m) compressed, expandable co-linear 3" x 3" flexible pipes and termination cap.

Other approved vent manufacturers

ICC, Selkirk, American Metals (Amerivent), Simpson Dura-Vent

2.2 Heating Specifications

	Natural Gas	LP Gas
Maximum Input Rating	34,000 Btu/h (9.96 kPa)	34,000 Btu/h (9.96 kPa)
Minimum Input Rating	18,500 Btu/h (5.42 kPa)	18,500 Btu/h (5.42 kPa)
Manifold Pressure (High)	3.8" WC (.95 kPa)	11" WC (2.74 kPa)
Manifold Pressure (Low)	1.1" WC (.27 kPa)	2.9" WC (.72 kPa)
Orifice Size (DMS)	#38	#52

2.2.1 Altitude Adjustment

This appliance may be installed at higher altitudes. Please refer to National Fuel Gas Code ANSI Z223.1/NFPA 54, CSA-B149.1 Natural Gas and Propane Installation Code, local authorities, or codes having jurisdiction in your area regarding derate guidelines.

2.2.1.1 US Installations

Refer to the American Gas Association guidelines for the gas designed appliances derating method. For elevations above 2,000 ft (610 m), input ratings are to be reduced by 4% for each 1,000 ft (305 m) above sea level.

2.2.1.2 Canadian Installations

When the appliance is installed at elevations above 4,500 ft (1,372 m), the certified high altitude rating shall be reduced at the rate of 4% for each additional 1,000 ft (305 m).

2.3 Appliance Dimensions

Table 2.1, Physical Dimensions								
Description	Height	Width	Back Width	Depth	Back Height	Back to Gas Line Access	Front to Vent Center	Back to Vent Center
Inches	23	33-3/8	24-3/8	16	17-3/8	5-9/16	10-3/8	5-5/8
Millimeters	585	848	618	407	442	142	264	143

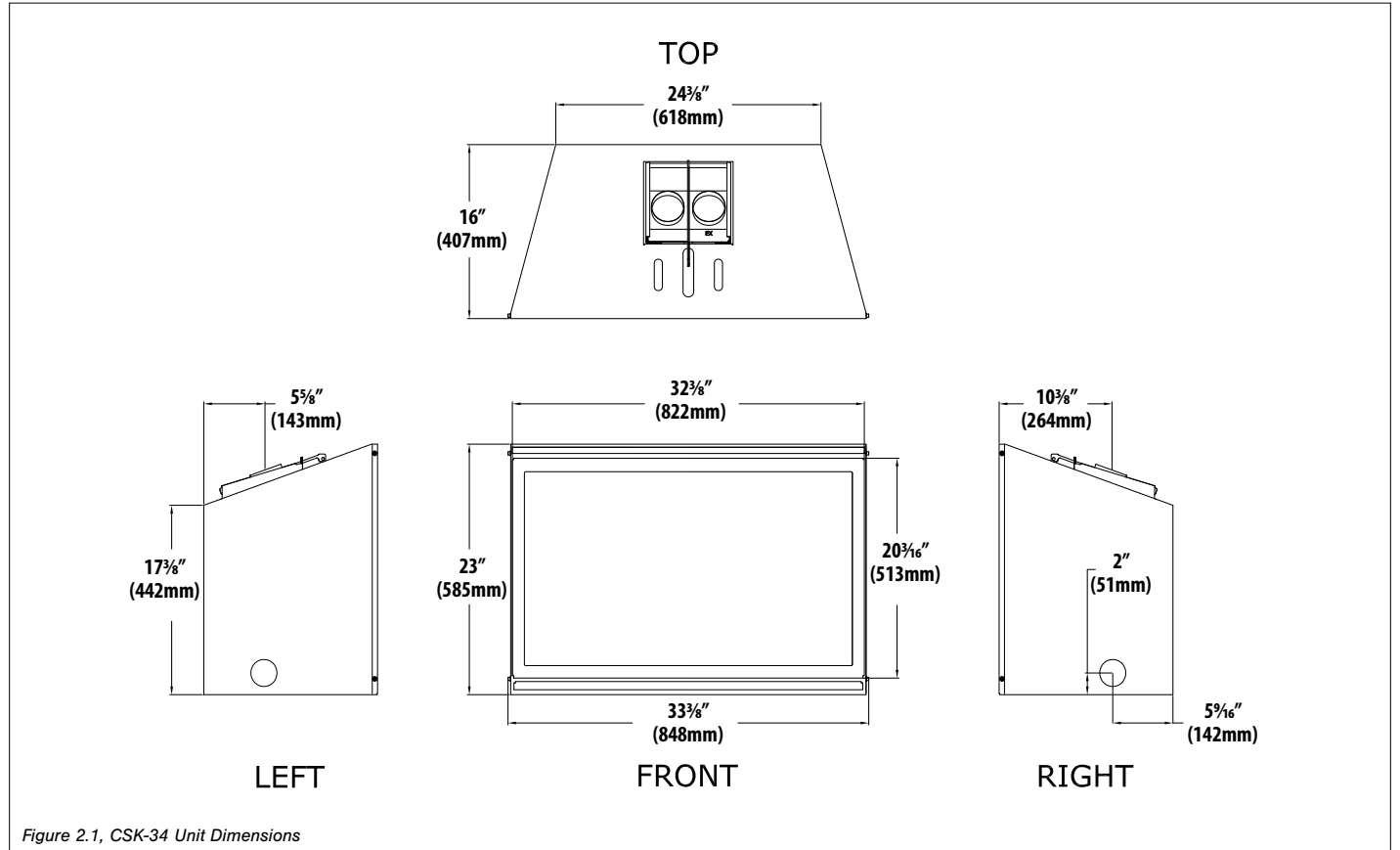

Figure 2.1, CSK-34 Unit Dimensions

2.4 Part Assembly Overview

WARNING: Failure to position these parts in accordance with these diagrams, or failure to use only specified approved parts with this appliance, may result in property damage or personal injury.

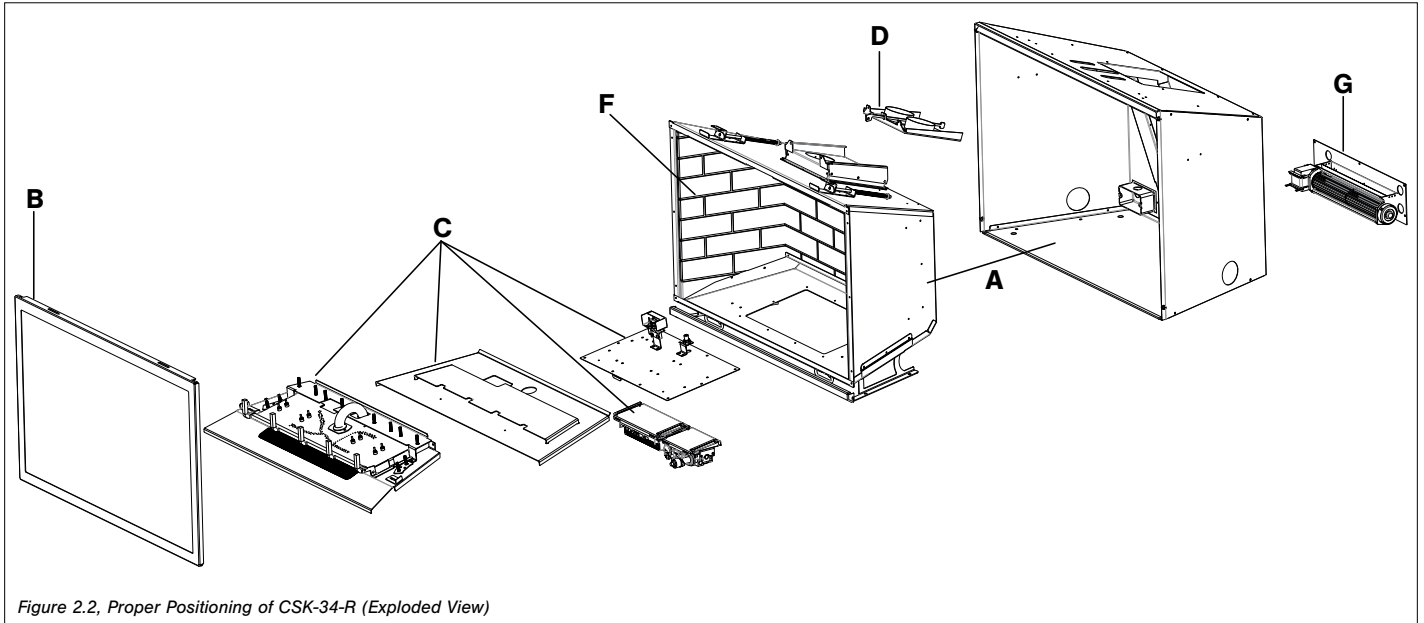

Figure 2.2, Proper Positioning of CSK-34-R (Exploded View)

Table 2.2, Field-Assembled Parts

A	Fireplace Insert	E	Rock Kit
B	Spring-loaded latch glass assembly	F	Refractory panels
C	Control board with burner cover	G	Fan kit
D	Co-linear air duct		

2.5 Safety Barriers

WARNING: A barrier designed to reduce the risk of burns from the hot viewing glass is provided with this appliance and shall be installed for the protection of children and other at-risk individuals.

If the barrier becomes damaged, the barrier shall be replaced with Hussong Mfg.'s barriers for this appliance. Only doors certified with the appliance shall be used.

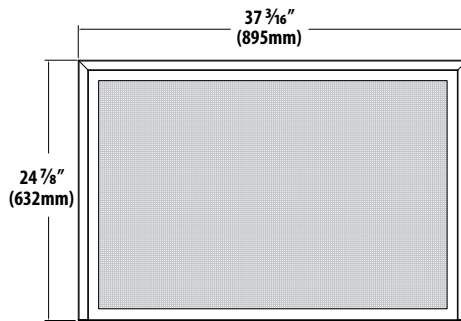

CK34-BSF

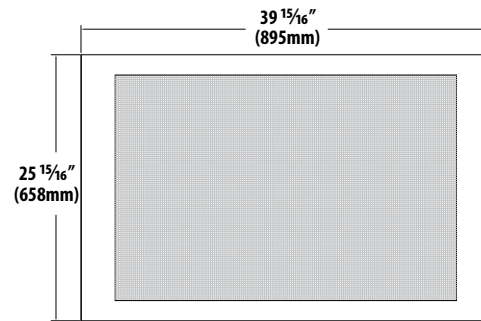

CK34-CXF

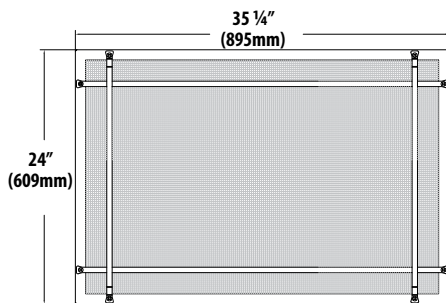

CK34-PSF

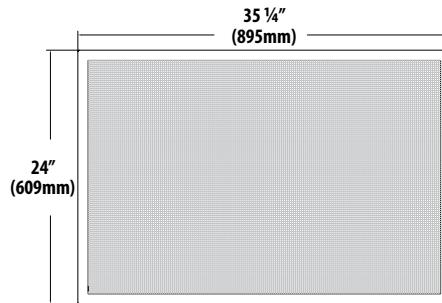

CK34-RSF

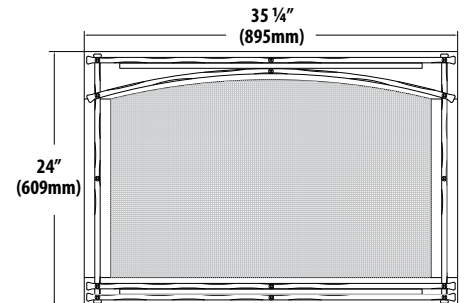

CK34A-MSF

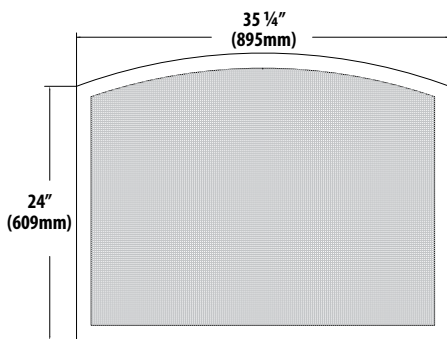

CK34A-SF

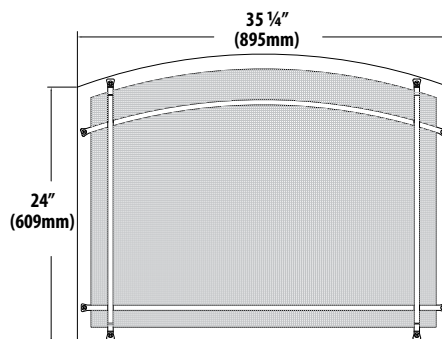

CK34A-PSF

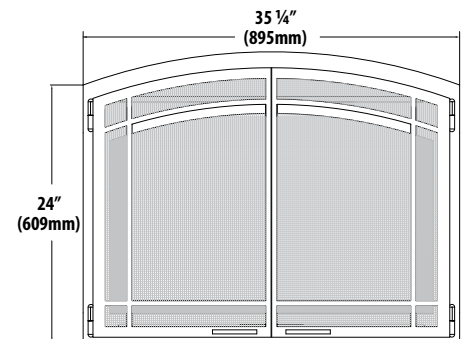

CK34A-FPDSF

3.0 EXISTING FIREPLACE REQUIREMENTS

3.1 Appliance Placement Considerations

WARNING: Due to high surface temperatures, the fireplace insert should be located out of traffic and away from furniture and draperies.

- This fireplace must be installed on a level surface capable of supporting the fireplace insert and venting.
- This fireplace insert may be installed in a bedroom.
- Please be aware of the large amount of heat this fireplace insert will produce when determining a location.

3.2 Existing Fireplace Specifications

IMPORTANT: Adequate accessibility clearances for servicing and proper operation must be maintained.

- Any smoke shelves, shields, and baffles may be removed if attached by mechanical fasteners. If necessary, remove firebrick to obtain at least the minimum opening requirements.
- Cutting of any sheet metal parts of the existing fireplace is prohibited.
- If the metal floor is removed, the insert must be placed directly on metal base of metal fireplace. Mechanically attach 'THIS UNIT HAS BEEN MODIFIED' label at bottom of existing firebox so it will be visible if this gas fireplace insert is removed.

3.2.1 Existing Fireplace Opening Minimum Requirements

- (A) Height..... 23-1/2 in (597 mm)
- (B) Front Width 33-1/2 in (851 mm)
- (C) Depth 16-3/8 in (419 mm)
- (D) Back Width 24-1/2 in (622 mm)

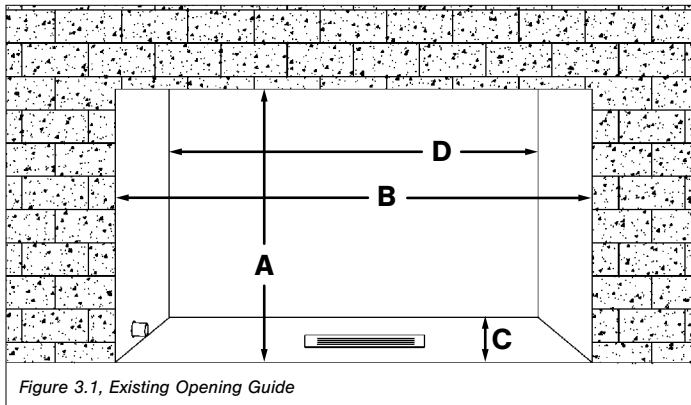

3.2.2 Existing Chimney Specifications

WARNING: Any chimney clean-outs must fit properly.

This fireplace insert is to be installed into a solid fuel masonry or factory built non-combustible fireplace that has been installed in accordance with the national, provincial, state, and local building codes.

The existing chimney must be comprised of one of the following:

- Factory-built solid fuel chimney: 7 in (178mm) minimum inside diameter
- Masonry chimney: 6 in x 8 in (152mm x 203mm) minimum inside diameter

Existing chimney height:

- Minimum: 12 ft (3.66 m) Maximum: 50 ft (15.24 m)

3.2.2.1 Determine Length of Existing Chimney

1. Remove and discard existing chimney cap.
2. It is helpful to have two people complete this step. Position one person at the fireplace and another person at the top of the chimney.
3. Measure from the fireplace base to the top of the chimney.
4. Subtract the height of the insert from the previous measurement. This is the total length of the co-linear flexible aluminum pipe required for your installation.

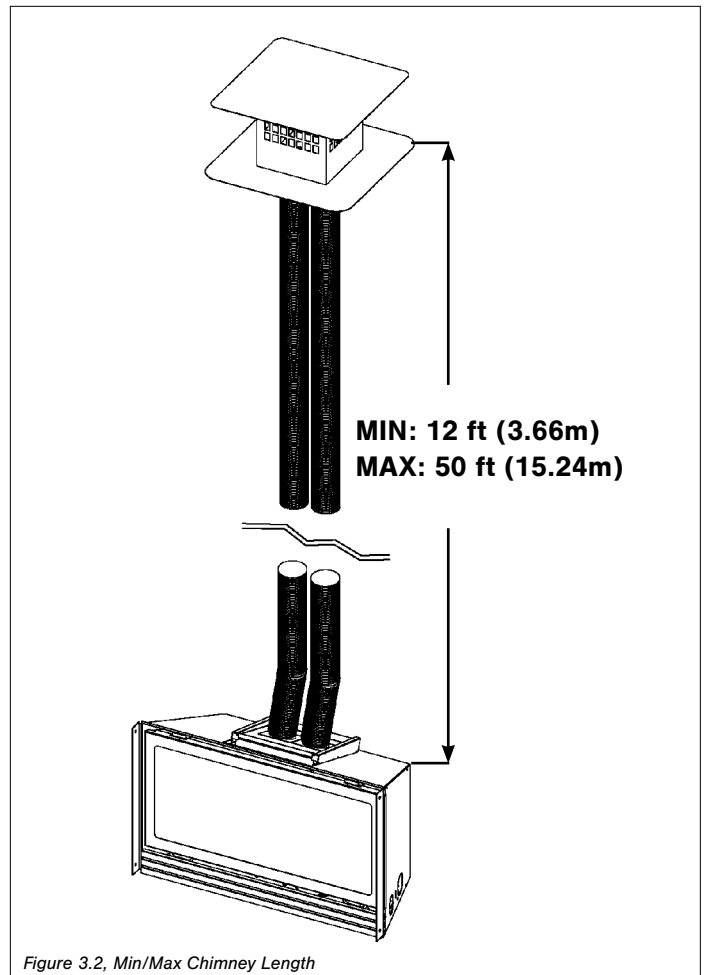

4.0 TERMINATION LOCATION

4.1 Vent Termination Clearances

WARNING: This appliance must not share or be connected to a chimney flue serving any other appliance.

- Approved vent caps require 12 in (305mm) clearance to intersecting walls, overhangs or eaves as verified by test.

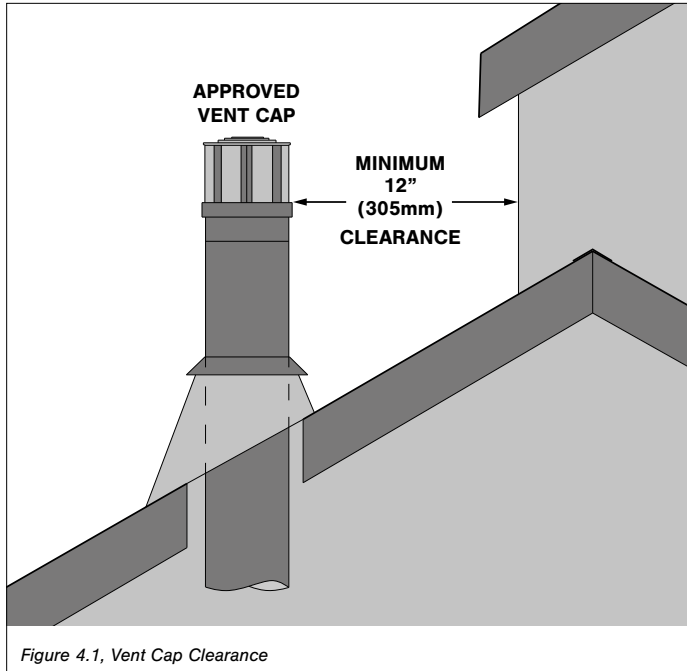

5.0 INSTALLATION PREPARATION

NOTE: This gas fireplace insert is approved for installation in masonry and factory-built solid fuel burning fireplaces.

ATTENTION: Any removed parts must be capable of re-installation if this insert is ever removed. Removal of rivets or screws is acceptable.

5.1 Inspect and Clean Existing Chimney

- Verify existing chimney is constructed of non-combustible material.
- Verify existing chimney is clean and in good working order. Clean existing chimney and fireplace to prevent a creosote odor from entering the home.
- Verify combustible mantel and sidewall clearances comply with Section 8.3 Safety Barrier Installations on page 19.
- The refractory, glass doors, screen rails, screen mesh, and log grates may be removed from existing fireplace before installing this gas fireplace insert.

5.2 Flue Damper

- The fireplace flue damper can be fully blocked open, or removed for installation of this gas fireplace insert. Remove existing chimney cap.

5.3 Gas Line

- A gas line must be able to be installed to the insert. Refer to Section 7.0 Gas Line Connection on page 18 .
- If the factory-built fireplace has no gas access hole(s) provided, an access hole of 1½ in. (37.5 mm) or less may be drilled through the lower sides or bottom of the firebox in a proper workmanship like manner. The access hole must be plugged with non-combustible insulation after the gas supply line has been installed.
- Run gas line to the gas fireplace insert through the gas line hole provided. Do not run gas line in a manner that would obstruct fan operation.
- If the gas fireplace insert is to be installed into minimum opening dimensions, the gas line may need to be run after appliance placement due to space limitations.

5.4 Electrical Wiring

- Provisions must be made to provide electrical power for appliance operation.
- Refer to Section 2.3 Appliance Dimensions (Figure 2.1) on page 9 for electrical outlet box location to run any necessary electrical wiring to the gas fireplace insert.

5.5 Fireplace Conversion

- Mechanically attach the label with the following warning to at the bottom existing firebox so it will be visible if this gas fireplace insert is removed.

WARNING: This fireplace has been converted for use with a gas fireplace insert only and cannot be used for burning wood or solid fuels unless all original parts have been replaced, and the fireplace re-approved by the Authority Having Jurisdiction.

6.0 INSTALLATION

6.1 Kozy Heat #816-CL Co-Linear Vent System

IMPORTANT: Proper operation of this insert requires the exhaust and combustion air pipes to be connected to the correct collar, on both the termination kit and the gas fireplace insert air duct.

The fireplace insert air duct exhaust collar is located on the right side. Install termination cap with the exhaust collar on the right side.

NOTE: The exhaust pipe will have a red marking.

IMPORTANT: Maximum horizontal vent runs of 24 in (609 mm) require a 1 in (25mm) rise per 12 in (305 mm) run.

1. Carefully extend the exhaust and combustion air intake pipes to the total chimney length required. Refer to 3.2.2 Existing Chimney Specifications on page 11.

2. Slide the combustion air intake pipe (the end without a collar) over termination cap collar (A). Secure to termination cap (E) with provided (3) self-tapping screws (D).
3. Place a bead of sealant around the inner edge at the end of the exhaust pipe (without collar / red marking) and slide onto the corresponding labeled collar (B) on termination cap (E).
4. Secure the exhaust pipe to termination cap (E) with the provided (3) self-tapping screws. Apply additional sealant around joint to ensure a proper seal.
5. Complete vent system installation.

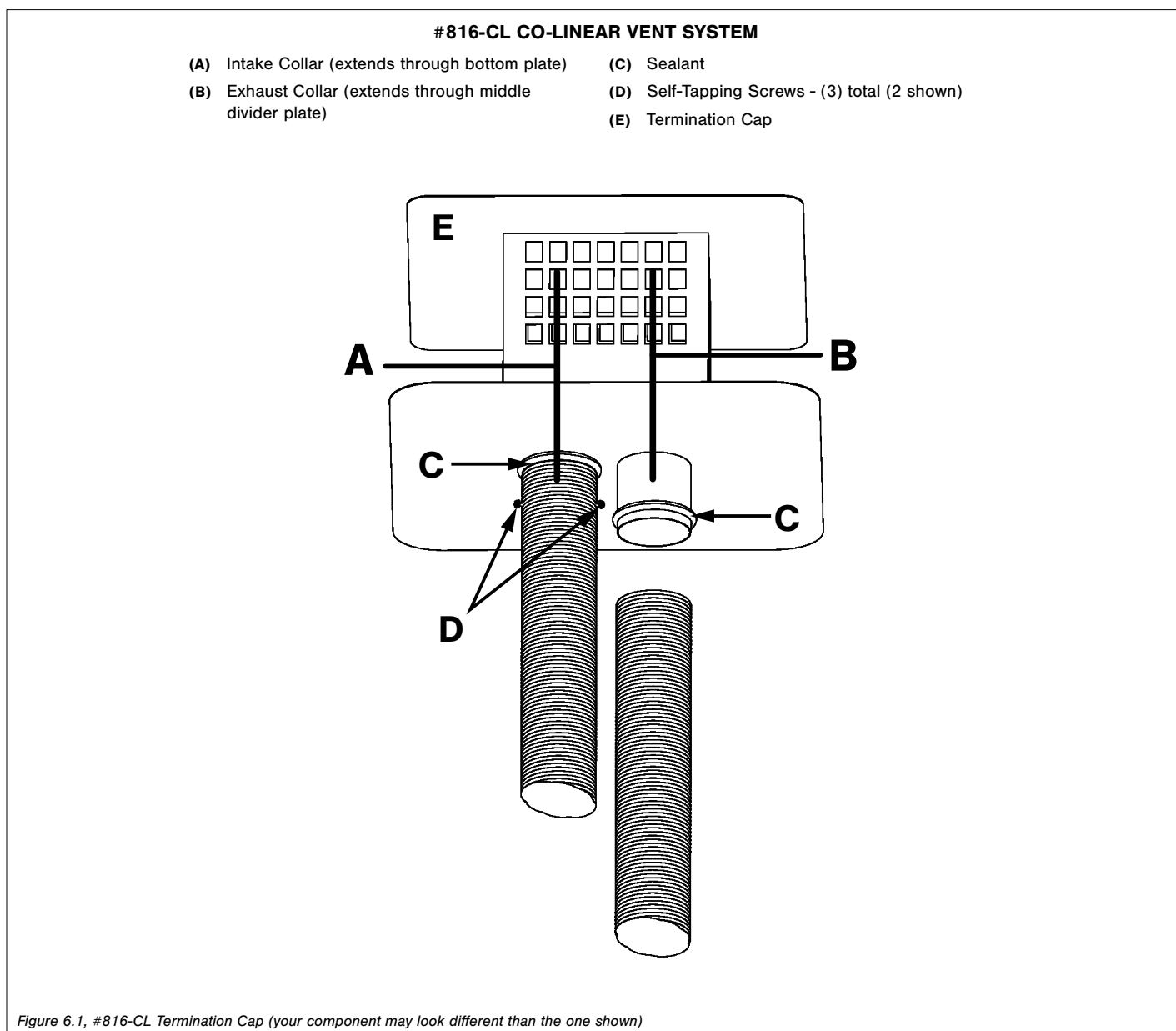

6.2 Fireplace Insert Air Duct Removal

ATTENTION: All information outlined in Section 5.0 Installation Preparation on page 13 must be completed before continuing with this installation.

1. Remove the air duct at the top of appliance by sliding the air duct back out of channels. Refer to the following instructions for re-attaching the air duct.

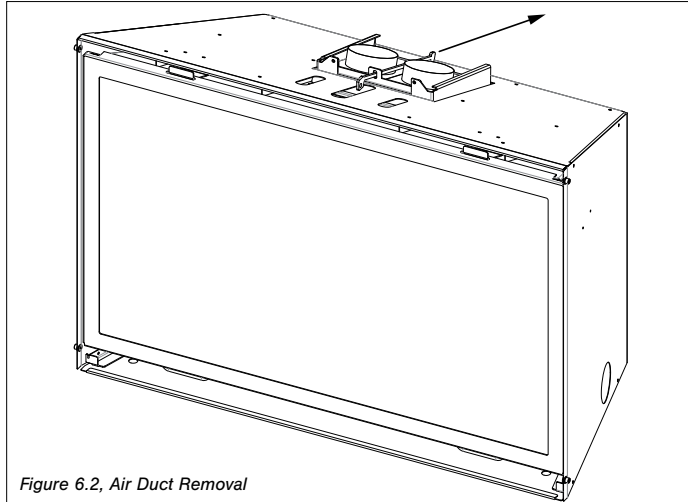

Figure 6.2, Air Duct Removal

6.3 Run Vent System

NOTE: If offsets are present in existing chimney, place a weighted rope around the pipe ends to guide them through the chimney. DO NOT ATTEMPT TO TIE ONE ROPE AROUND BOTH PIPES.

- To prevent cold air drafts, Hussong Manufacturing recommends to insulate the 3" x 3" flexible vent pipes and chimney using unfaced insulation products listed as noncombustible per ASTM E 136.
1. OPTIONAL: Before installing vent system down through the chimney, place unfaced insulation around the first 3 ft (914 mm) of vent system below termination cap. Secure with wire.
 2. Install the 3" x 3" flexible pipes down through existing chimney. Guide ropes (if used) to aid installation.
 3. To secure chimney termination cap to chimney, apply a liberal bead of sealant (provided) around the top of the chimney. Set termination cap into position as instructed by vent system manufacturer's installation manual.
OPTIONAL Kozy Heat #816-CL: Secure termination cap to existing chimney with 2 in (50 mm) self-tapping screws and anchor straps (provided) through the pilot holes, located on the sides of the termination cap.
 4. From inside the existing fireplace, carefully pull ropes (if used) or the flexible pipes down until both exhaust pipe and combustion air intake are into the existing fireplace firebox.
 5. OPTIONAL: To prevent heat loss up chimney, place unfaced insulation products between the 3" x 3" flexible vent pipes and chimney.

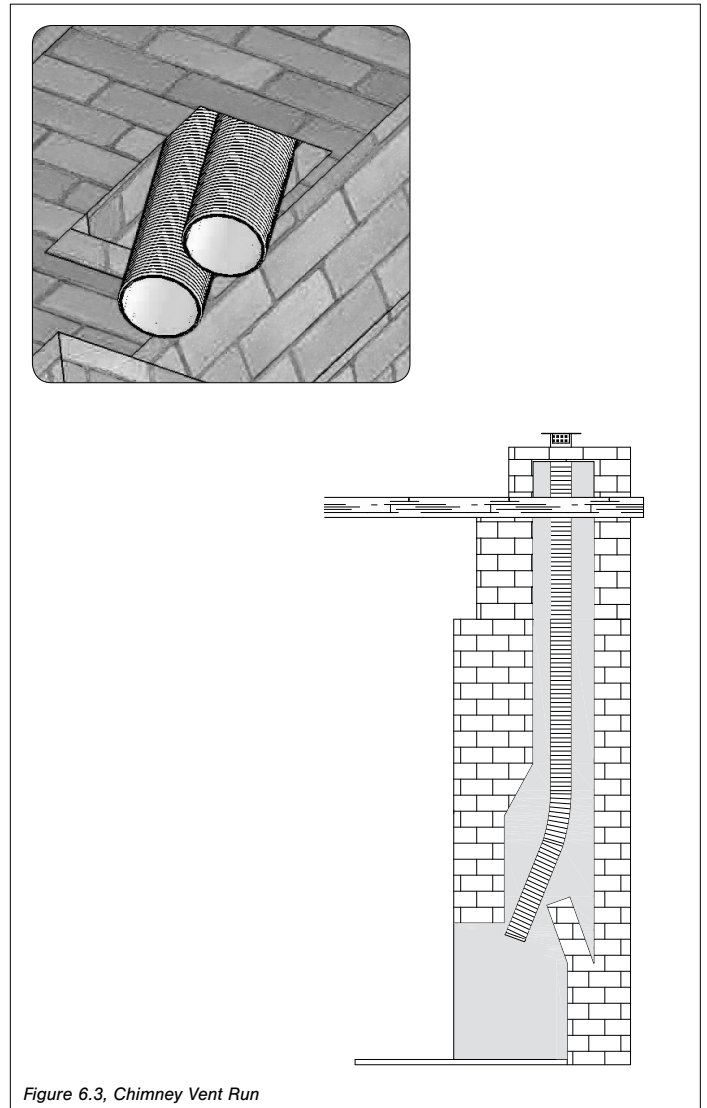

Figure 6.3, Chimney Vent Run

6.4 Connect Vent Pipe to Air Duct

IMPORTANT: Proper operation of this appliance requires exhaust and combustion air pipes to be connected to the correct collar, on both the termination kit and the gas fireplace insert air duct.

1. Place previously removed air duct (Section 6.2 on page 15) into existing fireplace opening.
2. Connect exhaust vent pipe (red marking) to exhaust collar on air duct. Apply a bead of sealant (provided) around exhaust pipe and slide inside collar marked 'Exhaust.' Secure with provided (3) 1/2 in (13 mm) self-tapping screws. Apply additional sealant around joint to ensure an air tight seal.
3. Connect air intake vent pipe to intake collar on air duct. Apply a liberal bead of sealant around intake collar on air duct. Slide combustion intake pipe over the collar and secure with provided (3) 1/2 in (13 mm) self-tapping screws. Apply additional sealant around joint to ensure an air tight seal.
4. Visually check vent pipe connection to air duct.

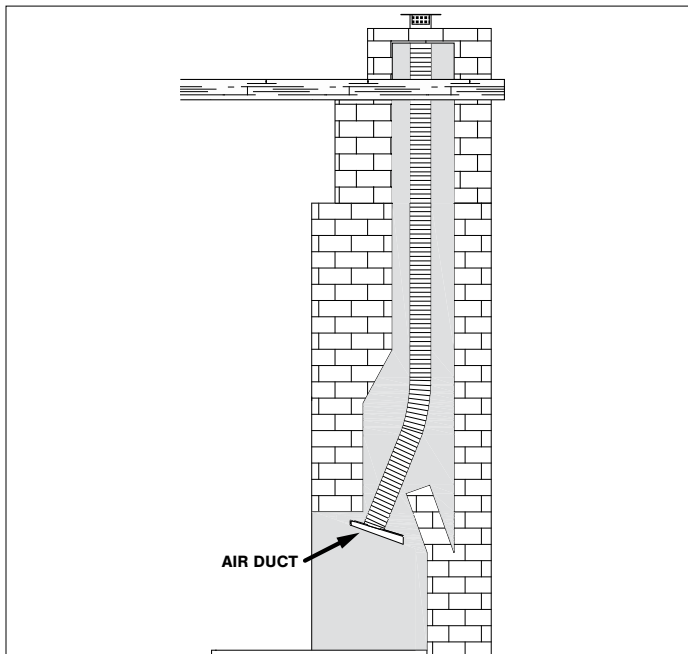

Figure 6.5, Air Duct in Existing Fireplace

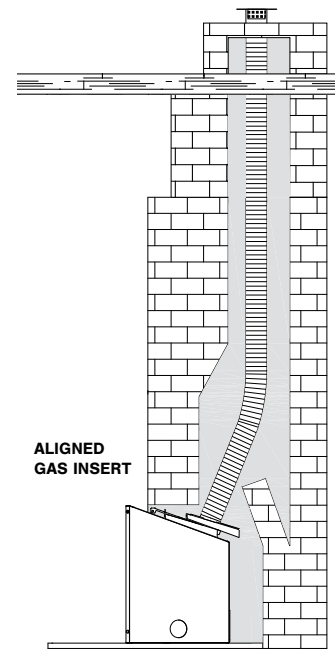

Figure 6.7, Aligned Gas Insert in Existing Fireplace

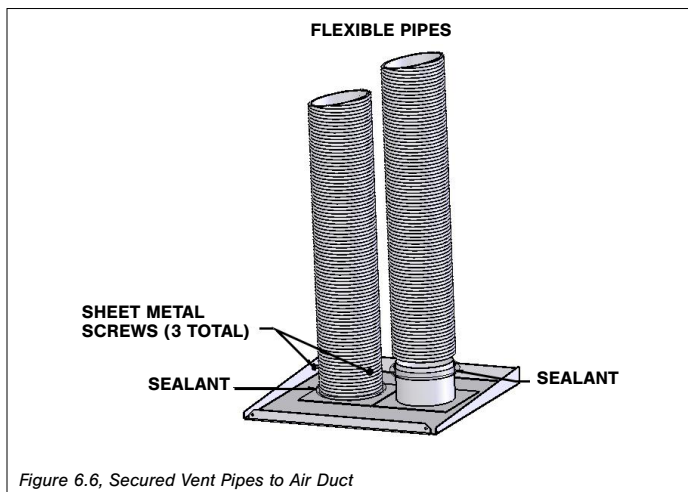

Figure 6.6, Secured Vent Pipes to Air Duct

6.5 Place and Secure Appliance

1. Slide the gas fireplace insert into existing fireplace opening until the channels on top of the appliance are aligned with the air duct.
2. Insert the air duct pull rod handle through access slot at the top of appliance and place pull handle hook through the hole in pull rod. Simultaneously push the gas insert into existing fireplace and pull the air duct forward until seated.
3. Secure air duct to appliance by using slots at the top of the appliance to secure with (2) 1/2 in (13 mm) sheet metal screws (included in components packet).
4. Use the pull rod handle to pull the air duct back to starting position. Remove pull handle. Verify vent system connection.
5. If necessary, level the gas insert by threading leveling bolts (included in components packet) into nuts at the bottom of the insert (2 each side). Verify appliance is properly positioned.

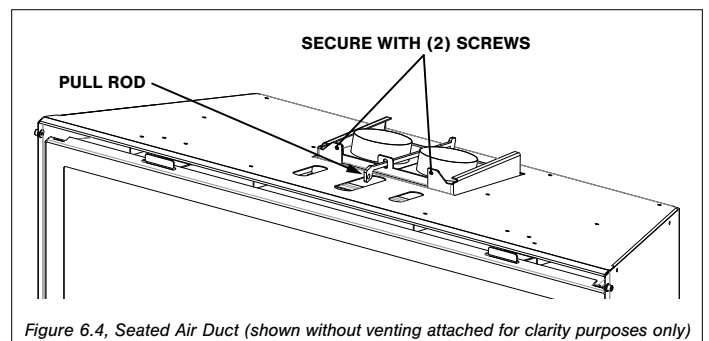

Figure 6.4, Seated Air Duct (shown without venting attached for clarity purposes only)

7.0 GAS LINE CONNECTION

7.1 Gas Conversion (sold separately)

ATTENTION: The conversion shall be carried out in accordance with the requirements of the provincial authorities having jurisdiction and in accordance with the requirements of the ANSI Z223.1 installation code.

This fireplace is manufactured for use with natural gas. Follow the instructions included with the conversion kit if converting to LP gas.

7.2 Gas Line Installation

CAUTION: Installation of the gas line must only be done by a qualified person in accordance with local building codes, if any. If not, follow ANSI 223.1. Commonwealth of Massachusetts installations must be done by a licensed plumber or gas fitter.

NOTE: The appliance and its individual shutoff valve must be disconnected from the gas supply piping system during any pressure testing of that system at pressures in excess of 1/2 psi (3.5 kPa). For test pressures equal to or less than 1/2 psi (3.5 kPa), the appliance must be isolated from the gas supply piping system by closing its individual manual shut-off valve.

- A listed (and Commonwealth of Massachusetts approved) 1/2 in. (13 mm) tee handle manual shut-off valve and flexible gas connector are to be connected to the 1/2 in. (13 mm) control valve inlet. If substituting for these components, please consult local codes for compliance.
- If installing this insert into minimum opening dimensions, the gas line may need to be run after placement due to space limitations. Refer to 3.2.2 Existing Chimney Specifications on page 11.
- This fireplace is equipped with a 3/8" (10 mm) x 18" (457 mm) long flexible gas connector and manual shut-off valve.
- Run gas line into fireplace, preferably through left or right gas line holes provided. The gas line should be run to the point of connection where the shut-off valve and flexible gas line will connect.
- Do not run gas line in a manner that would obstruct fan operation.
- For high altitude installations, consult the local gas distributor or the authority having jurisdiction for proper rating methods.

Table 7.1, Inlet Gas Supply Pressures

Fuel	Minimum Pressure	Maximum Pressure
Natural Gas	5" WC (1.25 kPa)	10.5" WC (2.62 kPa)
LP Gas	11" WC (2.74 kPa)	13" WC (3.24 kPa)

8.0 FACING AND FINISHING

8.1 Clearances to Combustibles

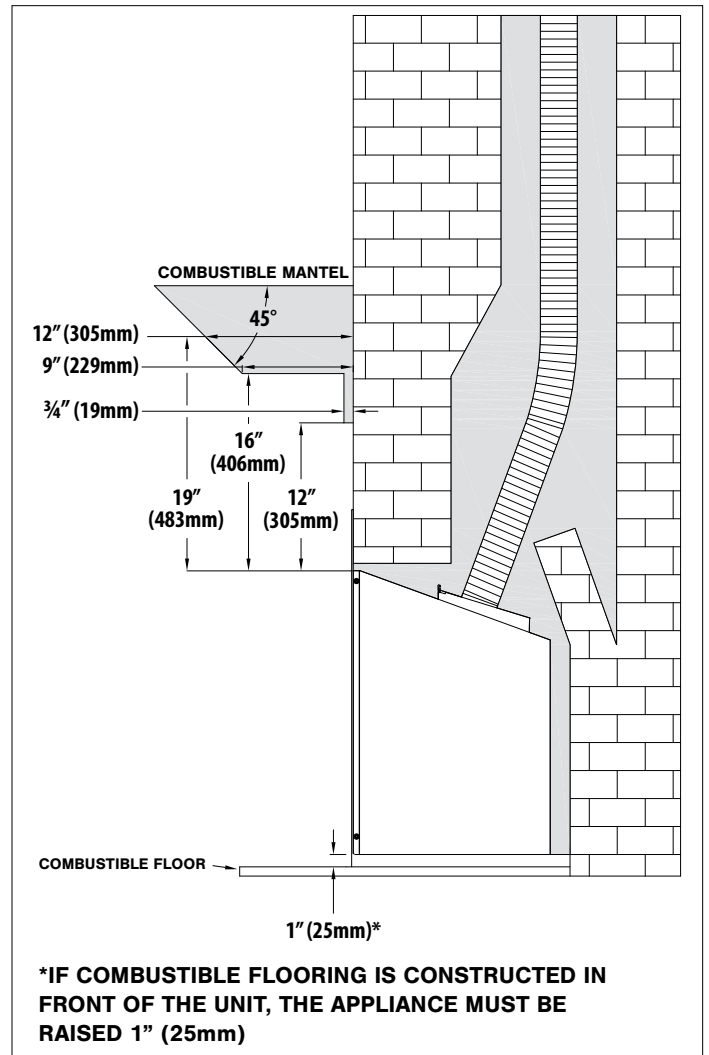
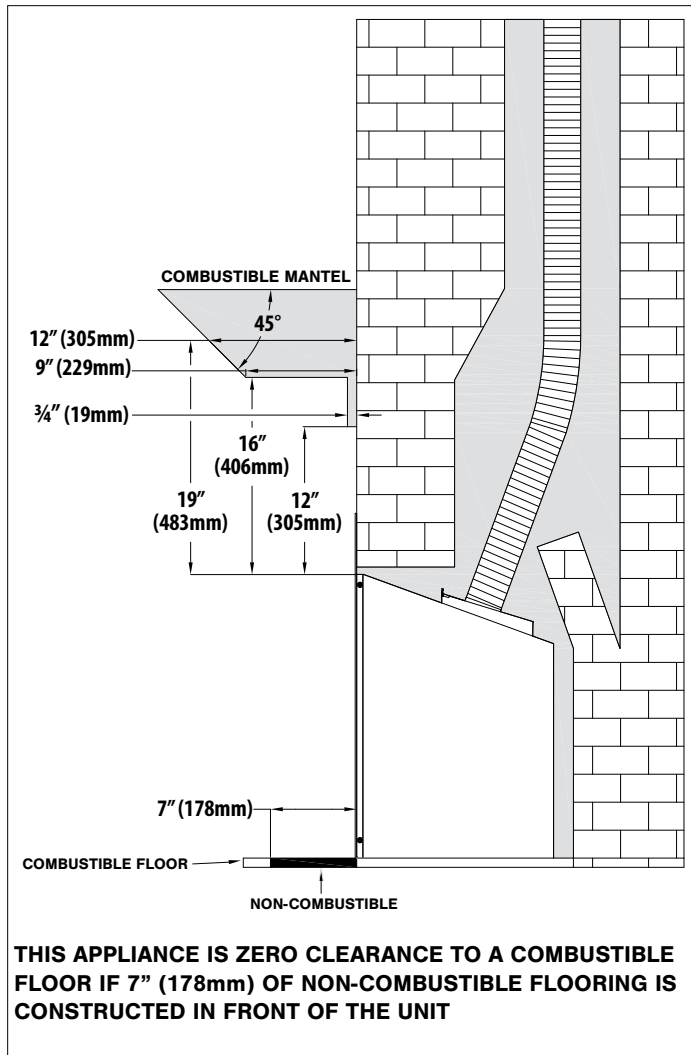
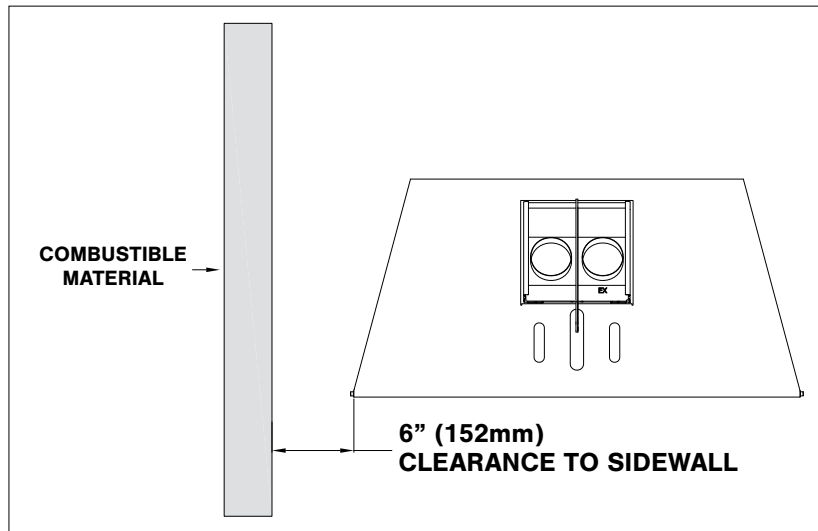

8.2 Shroud Installation

CAUTION: Trim panels or surrounds must not seal ventilation openings in existing fireplace that this appliance is installed in.

WARNING: The flow of combustion and ventilation air must not be obstructed.

For shrouds #CK34-2740, #CK34-3044, #CK34-3346, #CK34-A344, #CK34-CUS, and #CK34-ACUS.

1. Remove the upper hood by lifting up and out of the mounting flanges.
2. Remove lower louver by lifting the louver out of the slots on the mounting bracket.
3. Remove the glass assembly.
4. Align the mounting holes on the shroud to the corresponding mounting nuts on the sides of the insert metal cabinet.
5. Secure with (4) truss head screws (provided).
6. Reinstall all components previously removed.

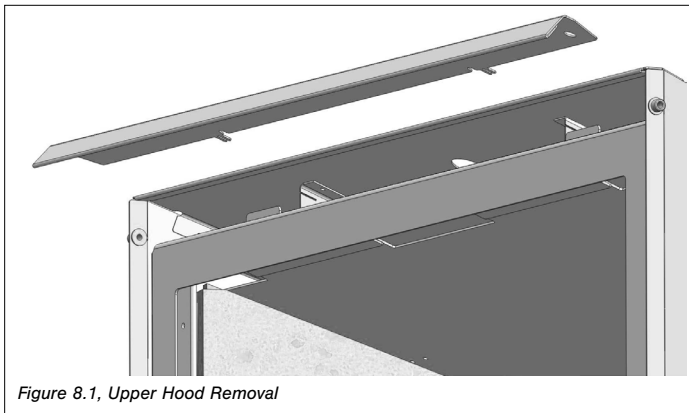

Figure 8.1, Upper Hood Removal

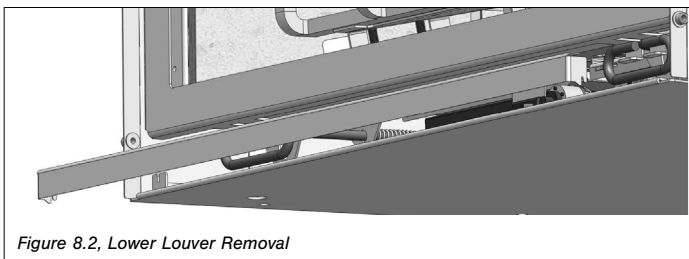

Figure 8.2, Lower Louver Removal

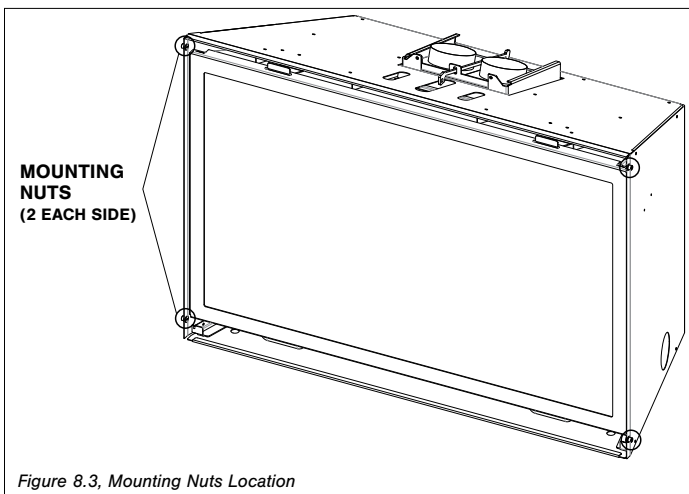

Figure 8.3, Mounting Nuts Location

8.3 Safety Barrier Installations

1. Locate the (4) slots on the shroud (2 each side).
 2. Align the tabs located on the back of the safety barrier with the slots on the shroud.
 3. Raise the safety barrier slightly into the slots and allow the tabs to lower into position.
- To remove safety screen: lift the screen up and out of slots.

9.0 FIREPLACE INSERT SETUP

9.1 Glass Assembly

WARNING: Do not operate this fireplace with the glass removed, cracked, or broken. Replacement of the glass assembly, #701-001T, should be done by a licensed or qualified service person.

9.1.1 Remove Glass Assembly

WARNING: Do not remove the glass assembly when hot.

1. Locate (2) spring-loaded latches securing the glass assembly at the bottom of the firebox.
2. Pull the spring-loaded latches out and down to release the bottom of the glass assembly.
3. Lift glass assembly up and off of the (2) tabs located at the top of the firebox.

9.1.2 Install Glass Assembly

1. Align the slots on top of the glass assembly over the tabs at the top of the firebox while lowering the bottom of the glass assembly into position.
2. Pull the spring-loaded latches out and up to secure the bottom of glass to the bottom of the fireplace.

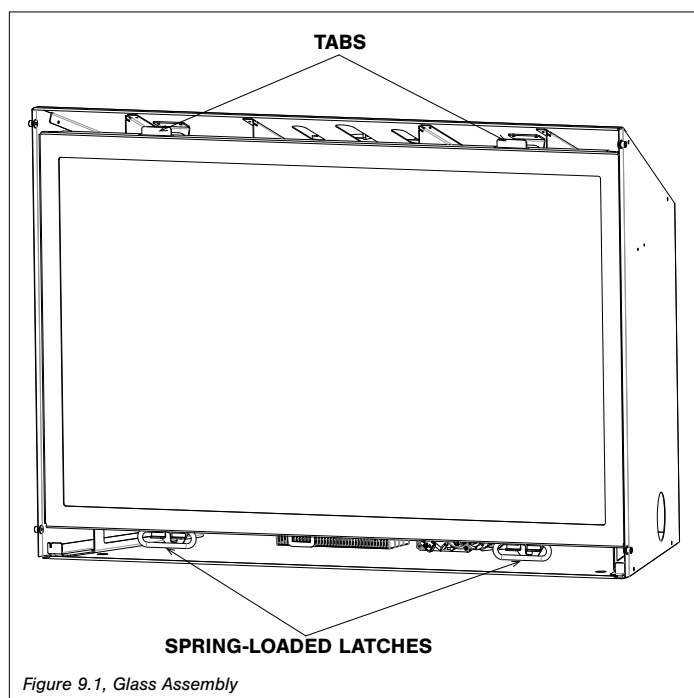

9.2 Light Kit

CAUTION: Disconnect all electrical power from the fireplace before performing this task.

ATTENTION: If converting to LP (propane) gas, complete the conversion before installing any light kit components. Follow the instructions provided with the conversion kit (sold separately).

NOTE: To avoid damage and prolong the life of the halogen bulbs, never touch with bare hands. Always use a soft cloth when handling.

9.2.1 Install Light Kit

1. Remove the safety barrier and glass frame assembly.
2. Remove rocks.
3. Remove the burner assembly, secured with (2) screws.
4. Remove side log mounting stands/refractory clips and refractory panels.
5. Remove the ember panel from the firebox.
6. Remove burner heat shield, secured with (2) screws at the back corners of the firebox.
7. Install (4) halogen bulbs (included in components packet) into lamp bases.
8. Reinstall ember panel.
9. Place 2 lb. (0.91 kg) of crushed glass media (included with fireplace) into ember media cavity. Randomly place klinkers on top of glass media.
10. Reinstall burner heat shield.
11. Reinstall side log mounting stands/refractory clips and refractory panels.
12. Reinstall burner assembly.
13. Reinstall rocks, glass frame assembly, and safety barrier.

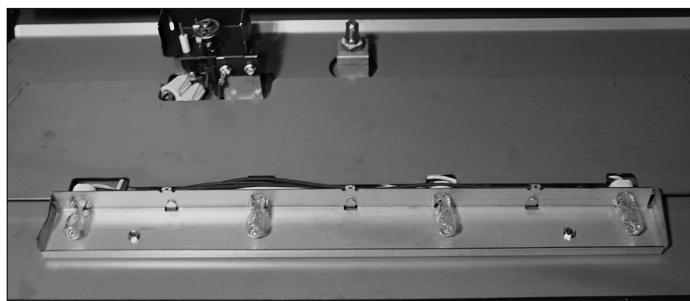

9.3 #CK34-R500 Rock Kit Installation

CAUTION: Do not place rocks directly over burner port holes. Improper rock placement may affect flame appearance and cause excessive soot to build upon the rocks and glass.

NOTE: Rock numbers are located on the bottom on of each rock. Follow the instructions and illustrations below.

- Remove refractory panels (if used or desired), the burner tube, and the back log plate.
1. Optional: Install (3) porcelain panels.
 2. Install the (2) rock brackets on the left and right side of the burner.
 3. Install the rock plate at the back of the firebox. Refer to
 4. Reinstall the burner tube. Verify gasket is underneath.
 5. Place the (8) spacers onto the pins on the burner. Tighten with the nuts included with this kit using a 5/16" nut driver.
 6. Align the holes in on the bottom each RX10 rock with the pins on the burner, as shown in Figure 9.6. Push to seat.
 7. Place rocks R6 and R1 over the burner tube as shown.
 8. Place rocks R11 as shown in . Distribute rockwool embers onto burner and base rocks using a stiff bristle brush.
 9. Place the rest of the rocks as shown in Figure 9.7. Distribute additional rockwell embers once completed.

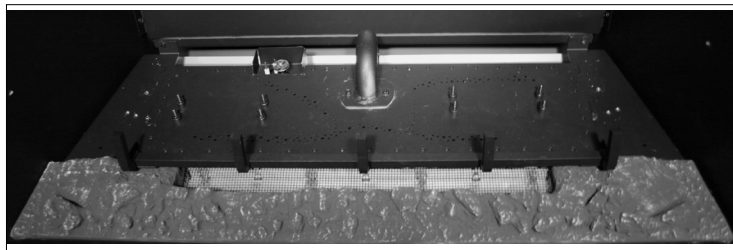

Figure 9.4, Removed Log Plate

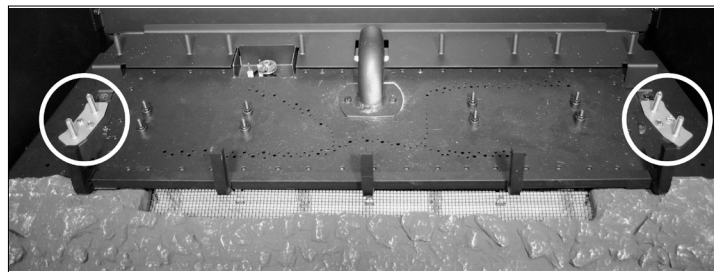

Figure 9.5, Installed Rock Plate and Brackets

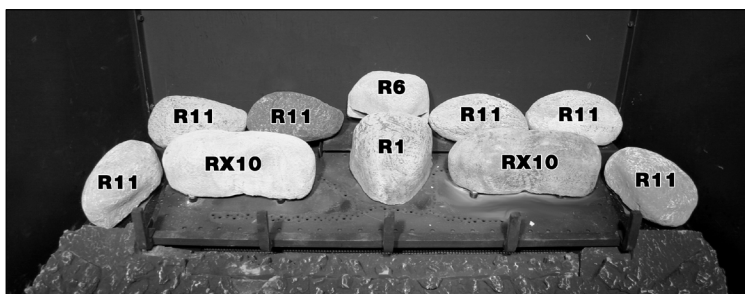

Figure 9.6, Rock Set Installation

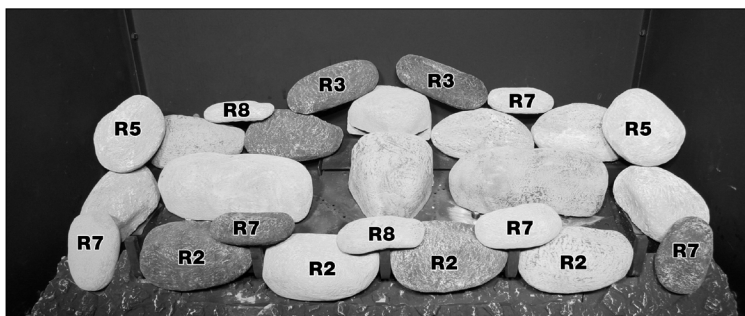

Figure 9.7, Completed Installation

9.4 Control Board Removal and Installation

WARNING: If burner and/or pilot have been burning, use appropriate protection to avoid burns or damage to personal property before removing any components. **DO NOT OPERATE THIS APPLIANCE WITHOUT THE SEALING GASKET (LOCATED UNDER THE CONTROL BOARD) IN PLACE. IF GASKETING IS DAMAGED, IT MUST BE REPLACED.**

CAUTION: Check all connections for leaks with soapy water, whether field or factory made.

9.4.1 Control Board Removal

1. Disconnect electrical power.
2. Locate the manual valve installed by your qualified service technician.
3. Turn the manual valve clockwise to the OFF position.
4. Remove the safety barrier and glass assembly.
5. Remove rocks.
6. Remove the burner assembly, secured with (2) screws.
7. Remove side log mounting stands/refractory clips and refractory panels.
8. Remove burner heat shield (secured at back corners - 2 screws).
9. Remove secondary burner heat shield resting on control board.
10. Remove (10) screws securing control board. Remove the control board.

9.4.2 Control Board Installation

1. Place the control board in firebox, aligning the holes in board with mounting studs at the bottom of the firebox. **VERIFY SEALING GASKET IS IN PLACE ON THE BOTTOM OF THE FIREBOX.**
2. Secure the control board with screws previously removed.
3. Reinstall secondary burner heat shield by placing it on top of the control board.
4. Reinstall burner heat shield. Position the cut-outs over pilot assembly and burner orifice, centering from side-to-side and as far back as possible.
5. Secure the burner heat shield with screws previously removed.
6. Reinstall refractory panels, then reinstall the side log mounting plates/refractory clips.
7. Reinstall burner assembly. Verify the burner tube is positioned over burner orifice. Secure with screws previously removed.
8. Reinstall rock kit.
9. Turn the manual valve counterclockwise to the ON position.
10. Reconnect electrical power.
11. Reinstall glass assembly and safety barrier.
12. Verify proper rock placement, operation of fireplace, and any electrical components.

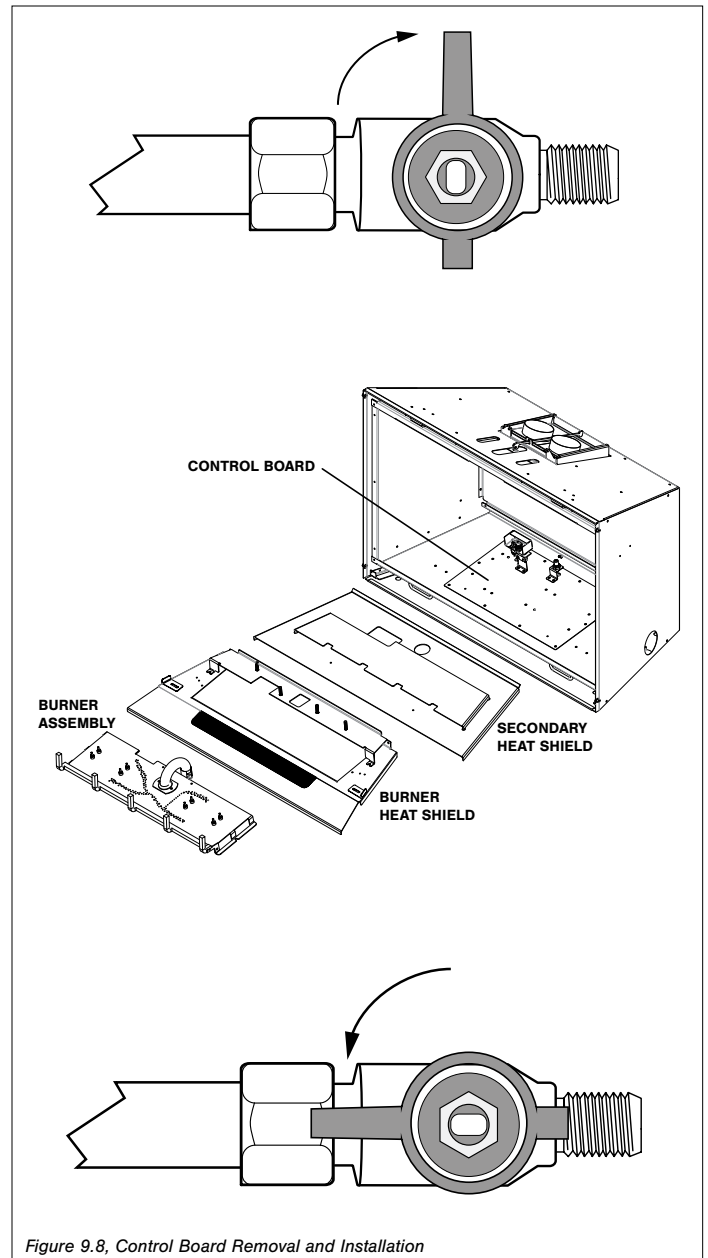

Figure 9.8, Control Board Removal and Installation

10.0 ELECTRICAL INFORMATION

WARNING: Do not use this fireplace if any part has been under water. Immediately call a qualified service technician to inspect this appliance and to replace any part of the control system and any gas control which has been under water.

WARNING - Electrical Grounding Instructions: This appliance is equipped with a three-prong (grounding) plug for your protection against shock hazard and should be plugged directly into a properly grounded three-prong receptacle. Do not cut or remove the grounding prong from this plug.

10.1 Electrical Specifications

This appliance, when installed, must be electrically grounded in accordance with local codes, or in the absence of local codes, with the National Electrical Code, ANSI/NFPA 70, or the Canadian Electrical Code, CSA C22.1.

10.2 Wiring Requirements

- The IFC System Module requires 120V of electricity and/or batteries to operate.
- Using the battery back-up will operate the burner only.
- Optional light components will not function on battery back up power.

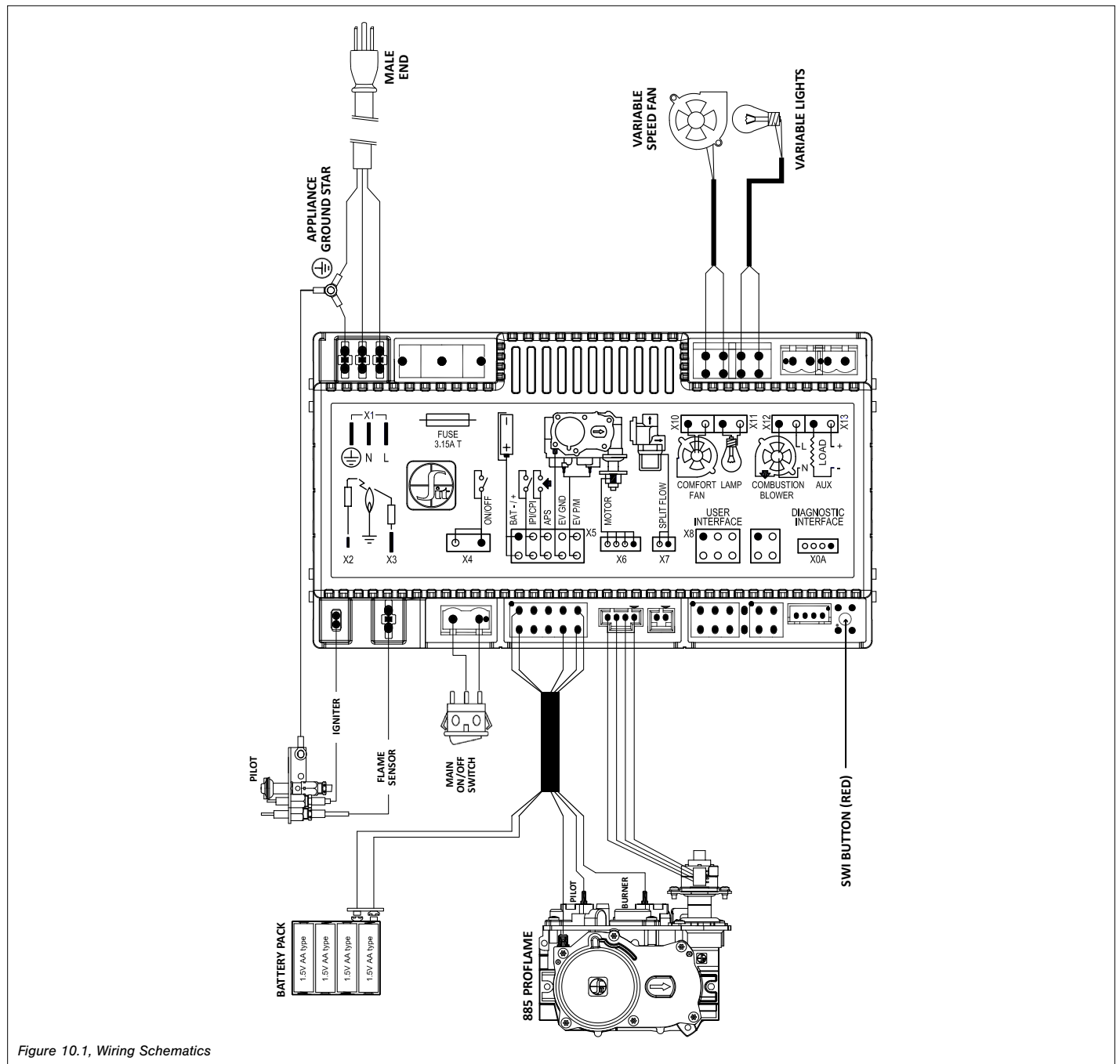

Figure 10.1, Wiring Schematics

11.0 OPERATING INSTRUCTIONS

FOR YOUR SAFETY READ BEFORE OPERATING

WARNING: If you do not follow these instructions exactly, a fire or explosion may result causing property damage, personal injury, or loss of life.

- A. This appliance is equipped with an ignition device which automatically lights the pilot. Do not try to light the pilot by hand.
- B. **BEFORE OPERATING** smell around the appliance area for gas. Be sure to smell next to the floor because some gas is heavier than air and will settle on the floor.
- WHAT TO DO IF YOU SMELL GAS**
- Do not try to light any appliance.
 - Do not touch any electric switch; do not use any phone in your building.
 - Immediately call your gas supplier from a neighbor's phone. Follow the gas supplier's instructions.
- If you cannot reach your gas supplier, call the fire department.
- C. Use only your hand to turn the gas control manual valve. Never use tools. If the valve will not turn by hand, do not try to repair it; call a qualified service technician. Force or attempted repair may result in a fire or explosion.
- D. Do not use this appliance if any part has been under water. Immediately call a qualified service technician to inspect the appliance and to replace any part of the control system and any gas control that has been under water.

WARNING

Do not operate appliance with the glass front removed, cracked, or broken. Replacement of the glass should be done by a licensed or qualified service person.

Under no circumstances should any solid fuel (wood, coal, paper, cardboard, etc.) be used in this appliance.



Children and adults should be alerted to the hazards of high surface temperature and should stay away to avoid burns or clothing ignition.

CAUTION

Clothing or other flammable material should not be placed on or near the appliance.

Young children should be carefully supervised when they are in the same room as the appliance. Toddlers, young children and others may be susceptible to accidental contact burns. A physical barrier is recommended if there are at risk individuals in the house. To restrict access to a fireplace or stove, install an adjustable safety gate to keep toddler, young children and other at risk individuals out of the room and away from hot surfaces.

OPERATING INSTRUCTIONS

1. STOP! Read all the safety information above on this page.
2. Press the wireless remote OFF button.
3. Turn off all electric power to the appliance.
4. This appliance is equipped with an ignition device which automatically lights the pilot. Do not try to light the pilot by hand.
5. Locate the manual valve installed by your qualified service technician.
6. Turn the manual valve clockwise  to the OFF position.
7. Wait five (5) minutes to clear out any gas. Then, smell for gas, including near the floor. If you smell gas, STOP! Follow 'B' in the safety information above. If you do not smell gas, go to the next step.
8. Turn the manual valve counterclockwise  to the ON position.
9. Turn on all electric power to the appliance.
10. Press the wireless remote ON button.
11. If the appliance will not operate, follow the instructions, "To Turn Off Gas To Appliance" and call your service technician or gas supplier.

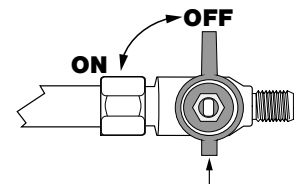
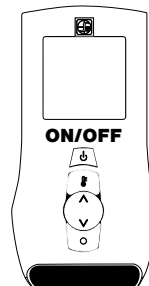

TO TURN OFF GAS TO APPLIANCE

1. Press the wireless remote OFF button.
2. Turn off all electric power to the appliance if service is to be performed.
3. Locate the manual valve installed by your qualified service technician.
4. Turn the manual valve clockwise  to OFF position.

NOTE

When this fireplace is initially lit, condensation will appear on the glass. This is normal in all gas fireplaces and will disappear after several minutes. A paint smell will occur during the first few hours of burning. It is recommended to leave the fan off during this period to help speed the paint curing process. This fireplace may produce noises of varying degree as it heats and cools due to metal expansion and contraction. This is normal, and does not affect the performance or longevity of the fireplace.

11.1 Initialize the Control System

Remove all packaging and combustible material from the firebox before initializing the control system.

1. Set the main ON/OFF switch in the OFF position.
 2. Install (4) AA batteries (included in the components packet) in the remote control battery bay, located at the base of the remote. Note the polarity of the batteries, and insert them as indicated by the silkscreen (+/-) on the battery cover or holder.
NOTE: Performing the next step will initiate pilot start-up in manual mode, where the pilot igniter will spark repeatedly. The pilot will ignite if gas is supplied to the fireplace.
 3. Locate the red SW1 button on the IFC module.
 4. Press the button. The IFC module will BEEP (3) times and illuminate an amber LED. This indicates the receiver is ready to synchronize with the transmitter.
 5. Within (5) seconds, push the ON/OFF button on the remote control. The receiver will BEEP (4) times to indicate the transmitter's command is accepted, and is set to the transmitter's particular code. The pilot will automatically ignite.
 6. Press the remote control ON/OFF button again. The pilot will extinguish, confirming the remote control command. The control system is now initialized.
 7. Set the main ON/OFF rocker switch to ON position for remote control operation of the main burner and fireplace features.
- If the pilot does not ignite, and the red LEDs indicator blinks (2) times in intervals, contact your dealer. This is a pilot flame error condition.

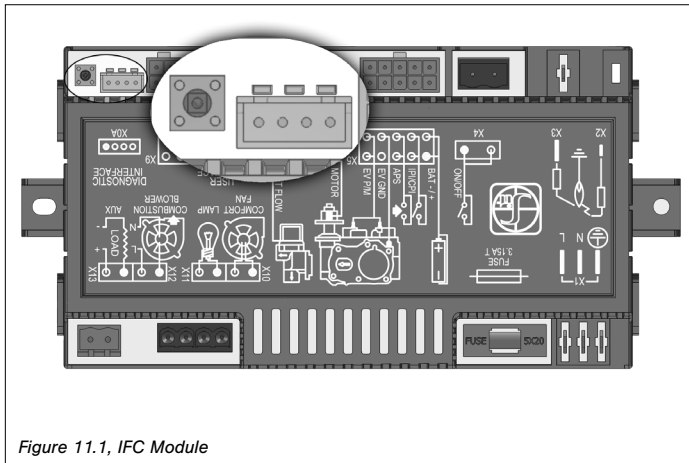

Figure 11.1, IFC Module

11.2 Backup Battery Operation

This appliance will operate on the backup battery pack when electric power is interrupted or in a power outage. The lifespan of the backup batteries depend on various factors, such as the quality of the batteries, number of ignitions, et cetera.

When the backup battery pack is low, the IFC module will emit a double-beep while receiving an ON/OFF command. After this alert for low battery condition, no commands will be accepted until the backup batteries are replaced. Once the batteries are replaced, the IFC module will emit a 'beep' as soon as it is powered.

11.3 IFC Module Ignition Sequence

- With the system in OFF position, press the remote control ON/OFF key. Approximately (4) seconds after this key is depressed, the IFC module will generate sparks to the pilot hood. The control module will spark for (60) seconds. If there is no flame ignition (rectification) within the (60) second time frame, the IFC module will stop generating sparks for approximately (35) seconds.
- After (35) seconds of wait time, the IFC module will generate sparks for another (60) seconds. If there is no positive rectification after the second ignition attempt, the IFC module will go into a lock out. The red LED will blink (3) times, in intervals, until the system is reset.
- Verify the gas supply is turned on and the sensor is not shorted.

Reset IFC Module after Lockout

ON/OFF Rocker Switch

- Set the ON/OFF rocker switch to the OFF position.
- After approximately (2) seconds, move the switch to the ON position. The ignition sequence will again.

Remote Control ON/OFF Key

- Press the remote control ON/OFF key to turn the system OFF.
- After approximately (2) seconds, press the ON/OFF key again. The ignition sequence will start again.

Cycling Flame

- Press the remote control down arrow key during flame adjustment mode to reduce the flame to OFF (indicated by OFF displayed on the LCD screen).
- After approximately (2) seconds, press the up arrow key. The ignition sequence will start again.

11.3.1 Automatic Safety Restart

- This system will execute an automatic turn OFF command within (24) hours of a continued pilot flame ignition. This allows the system to verify correct safety functions.
- After the turn OFF sequence is completed, the IFC module will re-execute the latest command.

11.4 Reset the System for Manual Operation

1. Set the ON/OFF rocker switch to OFF position.
2. Press the red SW1 button on the IFC module until it emits (3) beeps and an amber LED is illuminated.
3. Within (5) seconds, press the red SW1 button again. This will close synchronization with the remote control. The pilot will automatically light.
4. Turn the main burner ON by setting the ON/OFF switch in ON position. The main burner will only operate on HI.
5. Turn the main burner OFF by setting the ON/OFF switch in the OFF position. The pilot will remain lit even if burner is turned off, provided CPI mode is turned on.

PROFLAME 2 TRANSMITTER

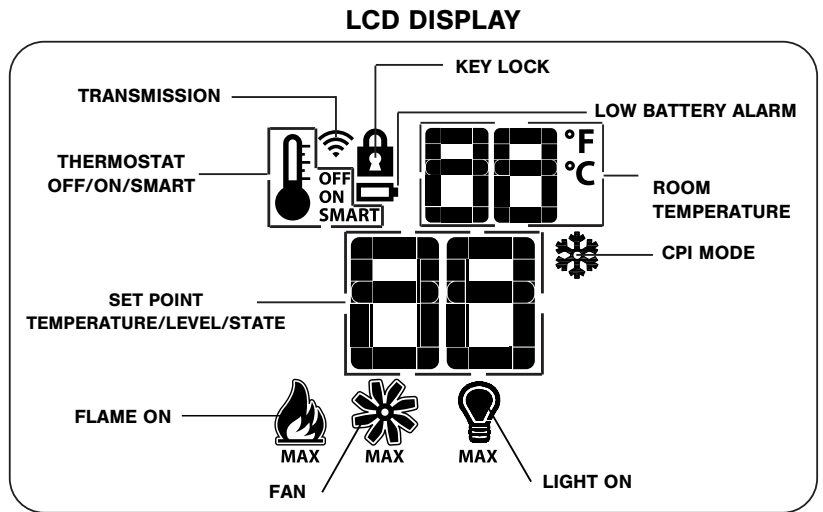
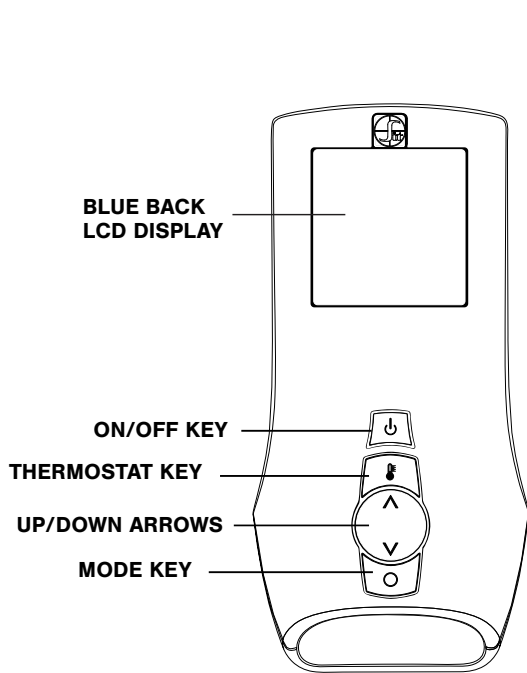

11.5 Remote Control Operation

11.5.1 Temperature Display

1. With the system in the OFF position, simultaneously press the thermostat key and the mode key to change degrees from °F to °C.
2. Visually check the LCD screen to verify either °F or °C is displayed on the right side of the room temperature display.

SYSTEM OFF

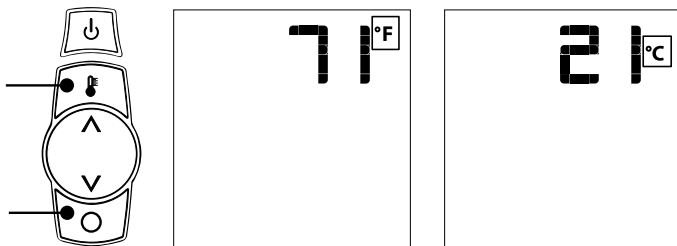

11.5.2 Key Lock

This function locks the keys to avoid unsupervised operation. Once activated, a lock icon will appear on the LCD screen.

1. Simultaneously press the mode key and the up arrow key to activate or deactivate this function.

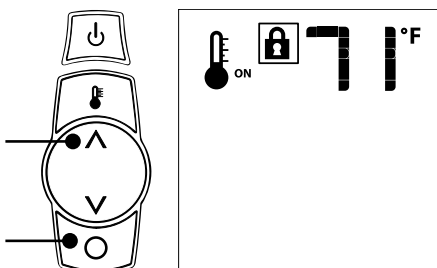

11.5.3 Pilot Ignition Selection (IPI/CPI)

This system has the option of a continuous (standing) pilot. This feature allows the system to change from a spark-to-pilot system to the standing pilot option. The standing pilot will keep the firebox warm and establish a draft in the vent, which allows the main burner to ignite with less air-flow disruption.

When the system is OFF, the LCD screen will display the snowflake icon during the setup of either IPI or CPI mode. To select the preferred pilot ignition feature,

1. With the system in the OFF position, press the mode key to index the CPI mode icon.
2. Press the up arrow key to activate CPI.
3. Press the down arrow key to return to IPI. A single 'beep' will confirm reception of the command.

When the system is ON,

- IPI mode - LCD screen will not display the snowflake icon
- CPI mode - LCD screen will display the snowflake icon

SYSTEM OFF

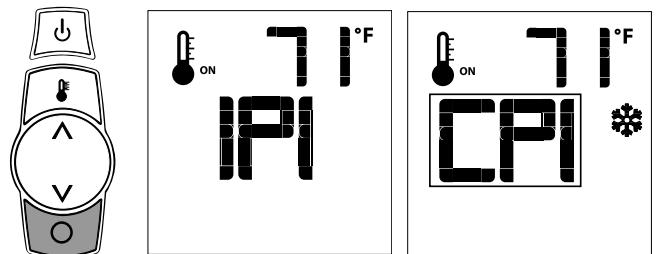

11.5.4 Turn ON the Appliance

- With the system in the OFF position, press the remote control ON/OFF key to turn ON the appliance. A single 'beep' will emit from the IFC module to confirm reception of the command.

The LCD screen will display all active icons, and the IFC module will start the ignition sequence.

11.5.5 Turn OFF the appliance

- With the system in the OFF position, press the remote control ON/OFF key to turn ON the appliance. A single 'beep' will emit from the IFC module to confirm reception of the command.

The LCD screen will only display the room temperature and its icon, and the IFC module will turn off the main burner.

11.5.6 Remote Control Flame Adjustment

This control system has (6) flame levels. If the smart thermostat operation is activated, then the manual adjustment of the flame height will be disabled.

- Verify the system is in the ON position and the flame level is set at maximum.
- Press the down arrow key once to reduce flame height by one level until the flame is turned off.
- Press the up arrow key once to increase flame height by one step. If the up arrow key is pressed while the system is on, but the flame is off, the flame will ignite on HI.
- A single 'beep' will confirm reception of the command.

SYSTEM ON



FLAME OFF

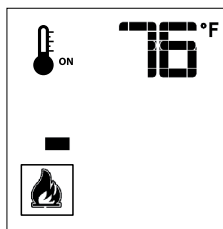

FLAME LEVEL 1

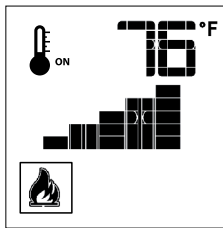

FLAME LEVEL 5

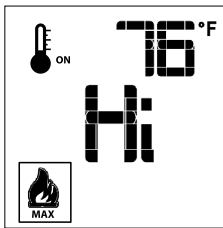

FLAME LEVEL MAXIMUM

11.5.7 Remote Control Thermostat Operation

11.5.7.1 Room Thermostat

The remote control can operate as a room thermostat. The thermostat can be set to a desired temperature to control a room's comfort level. To activate this function,

- Press the thermostat key. The LCD screen will display a temperature bulb graphic, the room temperature and set temperature.
- To adjust the set temperature, press the up or down arrow keys until the desired temperature is displayed on the LCD screen.

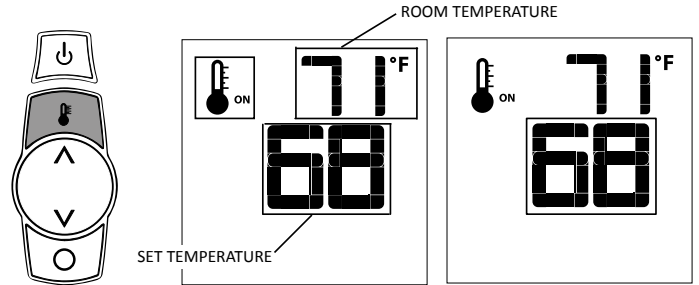

11.5.7.2 Smart Thermostat

The smart thermostat function will adjust the flame height based on the set temperature and the actual room temperature. The smart thermostat function automatically adjusts the flame down when the room temperature reaches the set point. To activate this function,

- Press the thermostat key until the 'SMART' appears on LCD screen on the right side of the temperature bulb graphic.
- To adjust the set temperature, press the up or down arrow keys until the desired temperature is displayed on the LCD screen.

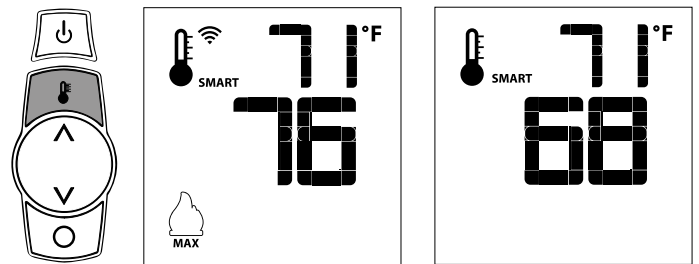

11.5.7.3 Deactivate Remote Control Thermostat Operation

The thermostat operation function can be deactivated. The remote control will still operate the main burner on and off, and function flame, fan, and light modulation. To deactivate this function,

- Verify all (3) AAA batteries are installed in the remote control.
- Remove (1) AAA battery.
- While reinserting the battery, push and hold the thermostat key. The temperature bulb graphic will not be displayed on the LCD screen.
- To reactivate remote thermostat operation, follow the same key sequence procedure above. The temperature bulb graphic will reappear on the LCD screen.

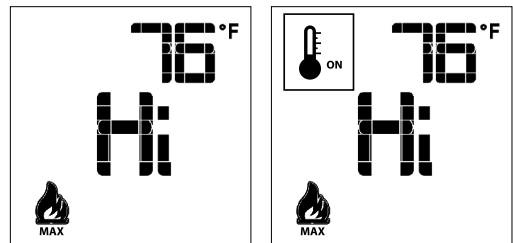

11.5.8 Fan Speed Control

Fan speed can be adjusted through (6) speeds. To activate this function,

Press the mode key to index to the fan control icon.

Press the up or down arrow keys to turn on, off, or to adjust fan speed.

Thermostat mode: Fan(s) have a (5) minute delay time when the fireplace is let. This allows time for heat to build in fireplace before fan operation. The fan will continue to operate for approximately (12) minutes after the fireplace has been turned off.

Manual mode: Fan(s) will operate at previous setting. There is no delay in start up or stop time.

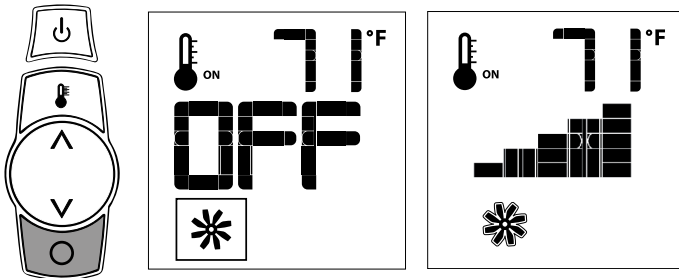

11.5.9 Accent Light Kit (Optional)

The light intensity can be adjusted through (6) levels.

1. Press the mode key to index to the light icon.
2. Press the up or down arrow keys to adjust the intensity level.
3. A single 'beep' will confirm reception of the command.

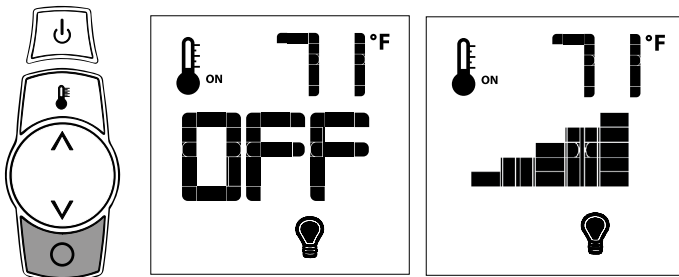

11.5.10 Remote Control Low Battery Detection

Remote control battery lifespan depends on various factors including battery quality, number of ignitions, changes to room thermostat set point, etcetera.

- When the remote control battery are low, a battery icon will appear on the LCD display before all battery power is lost.
- When the batteries are replaced, this icon will disappear.

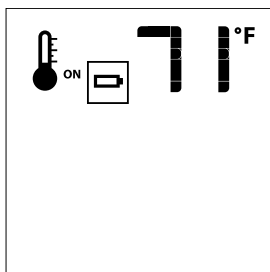

12.0 ADJUSTMENT

12.1 Pressure Testing

NOTE: The appliance and its appliance main gas valve must be disconnected from the gas supply piping system during any pressure testing of the system at test pressures in excess of 1/2 psi (3.5 kPa).

IMPORTANT: Pressure check taps for manifold (outgoing) and inlet (incoming) pressure have been incorporated into the valve. The pressure tap marked OUT measures outgoing pressure. The pressure tap marked IN measures incoming pressure.

12.1.1 Inlet Pressure Test

NOTE: Make sure to apply these incoming pressure test with all other gas appliances on, or at full capacity in the house for proper pressure reading.

IMPORTANT: If the inlet pressure reading is too high or too low, contact the gas company. Only a qualified gas service technician should adjust incoming gas pressure.

1. Loosen the inlet (IN) pressure tap by turning screw counter-clockwise. See (A) in Figure 12.1.
2. Attach manometer using a 1/4 in (6 mm) I.D. hose.
3. Light pilot and burner. Check pressure to ensure it is between the minimum and maximum recommended pressure settings.
4. Turn off burner and pilot.
5. Disconnect hose and tighten the inlet (IN) pressure tap by turning screw clockwise. Screw should be snug. Do not over tighten.
6. Relight pilot and burner. Then reattach manometer to the inlet pressure tap (A) to verify the tap is completely sealed. Manometer should read no pressure.

12.1.2 Manifold Pressure Test

1. Light pilot.
2. Loosen manifold (OUT) pressure tap by turning screw counter-clockwise. See (B) in Figure 12.1.
3. Attach manometer to pressure tap using a 1/4 in (6 mm) I.D. hose.
4. Light burner. Check manometer reading.
5. Turn burner and pilot off.
6. Disconnect manometer hose and tighten the manifold (OUT) pressure tap by turning screw clockwise. Screw should be snug. Do not over tighten.
7. Attach the manometer to the manifold pressure tap (B) to verify it is completely sealed. The manometer should read no pressure when pilot and burner are on.

Table 12.1, Inlet Pressures

Fuel	Natural Gas	LP Gas
Gas Supply	Min - Max	Min - Max
Inlet Pressure Tap (A)	5" - 10.5" WC (1.25 - 2.62 kPa)	12" - 13" WC (2.99 - 3.24 kPa)

Table 12.2, Manifold Pressures

Fuel	Natural Gas	LP Gas
Gas Supply	Low - High	Low - High
Manifold Pressure Tap (B)	1.1" - 3.8" WC (.27 - .95 kPa)	2.9" - 11" WC (.72 - 2.74 kPa)

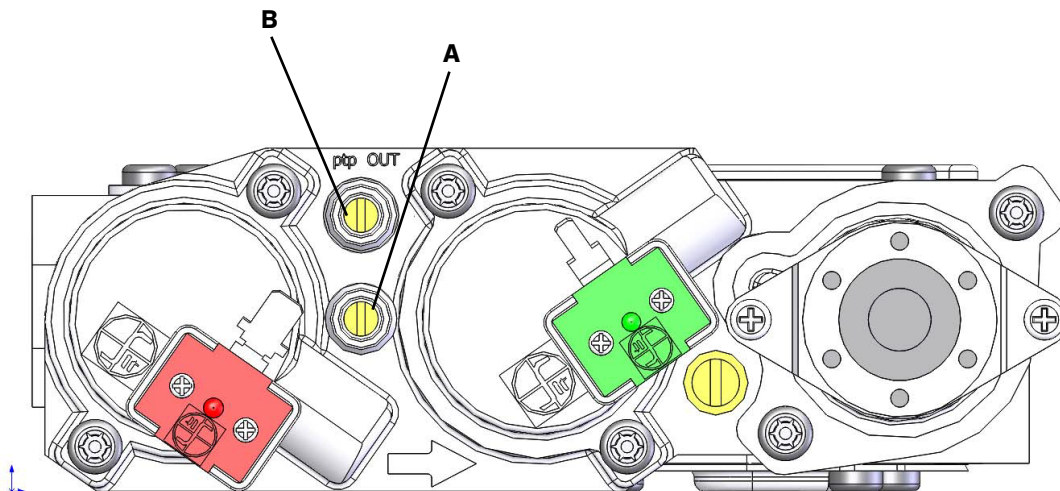

Figure 12.1, Pressure Check Taps

12.2 Flame Appearance Adjustments

12.2.1 Burner Venturi

WARNING: To avoid property damage or personal injury, allow the fireplace ample time to cool before making any adjustments.

NOTE: Venturi settings have been factory set. Refer to Table 12.3.

Burner flame appearance is affected by several factors, including altitude, venting configuration, and fuel quality. After installation, this appliance may need additional adjustments to achieve optimal performance and visual aesthetics.

When this appliance is first lit, the flames will appear blue, then gradually turn yellowish-orange during the first 15 minutes of operation. If the flames remain blue, or become dark orange with evidence of sooting (black tips), the burner tube venturi may need adjustment.

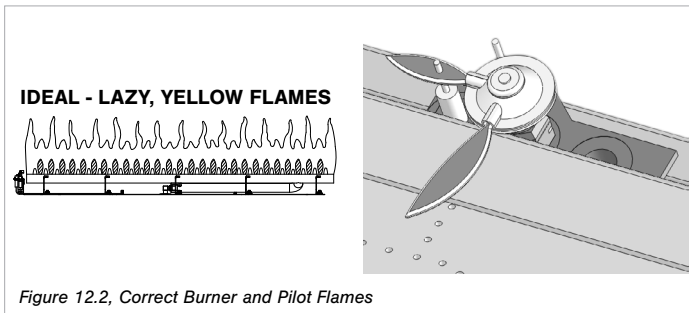

Figure 12.2, Correct Burner and Pilot Flames

Table 12.3, Factory Set Venturi Openings	
FUEL	VENTURI SETTING
NG	1/8 in (3 mm) OPEN
LPG	5/8 in (16 mm) OPEN

12.2.2 Venturi Adjustment

WARNING: Venturi adjustment should only be performed by a qualified personal service technician.

NOTE: If soot is present on the glass, check log positioning before adjusting the venturi. Logs must not block burner ports.

1. Remove the safety barrier and glass frame assembly.
2. Remove the log set and burner assembly from the firebox.
3. Loosen screw on venturi and adjust as necessary. Tighten screw.
4. Reinstall all components previously removed.

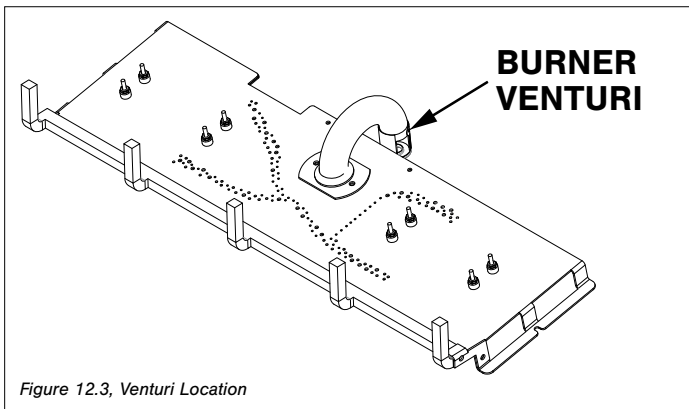

Figure 12.3, Venturi Location

IMPORTANT: Slight adjustments to the venturi opening will create dramatic results. Adjust at slight increments until desired look is achieved. Always burn the fireplace for at least 15 minutes, and always allow the appliance ample time to cool before making any further adjustments.

Use the table and the illustrations below to achieve desired flame appearance.

Table 12.4, Venturi Adjustment Guidelines		
Flame Characteristic	Cause	Solution
Dark, orange flame with black tips	Venturi closed too far	Open venturi slightly
Short, blue flames	Venturi open too far	Close setting slightly
Lifting (ghosting) flames	Improper venting Gas pressure too high Venturi closed too far	Check vent pipe and vent cap Check manometer settings Open venturi setting slightly

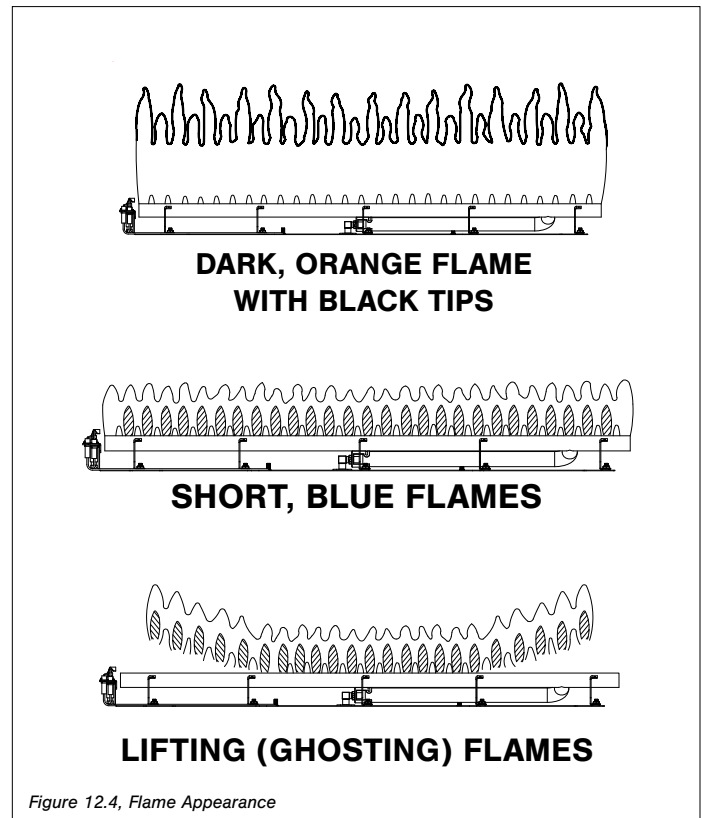

Figure 12.4, Flame Appearance

13.0 TROUBLESHOOTING

ATTENTION: Troubleshooting must be performed by a qualified technician.

Before proceeding with the steps in the following troubleshooting guide,

- Verify proper 120VAC power supply to the control module.
- Verify the control module battery pack and the remote control batteries are fresh and installed with correct polarity.
- Verify all connections between the wire harnesses and the system components are proper and positive.
- Verify the communication link is established between the remote control and the IFC module.
- Verify inlet pressure meets the recommended inlet pressure. If necessary, adjust line pressure regulator.

Issue	Cause	Solution
Pilot will not light	Electrical power interrupted or disconnected	Restore electrical power to fireplace or use battery back-up.
	Wiring disconnection	Ensure batteries are fully charged if using battery back-up as power source.
	Gas Supply turned off	Use wiring schematic in this manual to determine that all wiring connections are secure and correct. Check remote shut-off valves from the fireplace. Usually there is a valve near the main gas line. There may be more than (1) valve between the fireplace and the main gas line.
Pilot will not stay lit	No LP gas in tank	Check LP (propane) tank. Refill if necessary.
	Low gas pressure	Consult a plumber or a gas supplier. Can be caused by situations such as a bent line, too narrow diameter of pipe, or a low line pressure.
	Pilot flame not making contact with the flame rectification sensor on the pilot assembly	Adjust the pilot flame adjustment screw on the gas valve as necessary.
	Pilot adjustment screw not sealed	Seal pilot adjustment screw. Do not over-tighten.
Pilot flame always on or will not extinguish	Control system set to CPI mode	Set control system to IPI mode.
Main burner flame will not light	ON/OFF rocker switch in OFF position	Switch rocker to ON position.
	Gas supply turned off	Check for multiple shut-offs in the supply line. Verify gas supply is turned on.
	Low gas supply	Consult with plumber or gas supplier. Check LP (propane) tank. Refill if necessary.
	Wiring disconnection or improper wiring	Check for faulty or incorrect wiring.
	Plugged main burner orifice	Remove blockage.
	Pilot flame	Verify the pilot flame is properly directed to ignite the burner. See pilot flame troubleshooting above.
	Remote control not working properly	Replace batteries.
	No call for heat	Verify remote control is powered ON and thermostat operation is turned OFF.

Issue	Cause	Solution
Pilot and burner extinguish while in operation	No LP gas in tank	Check LP (propane) tank. Refill if necessary.
	Incorrect glass assembly installation	Refer to 9.1 Glass Assembly on page 20.
	Incorrect vent cap installation	Adjust if necessary
	Vent cap blockage	Remove debris if necessary
	Inner vent pipe leaking exhaust gases back into the firebox	Check for leaks and repair if necessary.
	Excessive draft	An exhaust restrictor may be necessary into the exhaust pipe outlet of the fireplace.
Soot appears on glass	Improper rock placement	Refer to 9.2 #CK34-R500 Rock Kit Installation on page 21.
	Improper venturi setting	Venturi may need to be opened slightly to allow more air into the gas mix. Refer to 12.2.1 Burner Venturi on page 30.
	Incorrect vent cap installation	Adjust if necessary
	Vent cap blockage	Remove debris if necessary
Flame burns blue and lifts off burner	Improper venturi setting	Venturi may need to be opened slightly to allow more air into the gas mix. Refer to 12.2.1 Burner Venturi on page 30.
	Incorrect vent cap installation	Adjust if necessary
	Blockage or leakage of the vent system.	Check the vent pipe for leaks and the vent cap for debris. Repair vent pipe or remove debris from vent cap if necessary.
No reaction to command	Battery pack batteries or remote control batteries low.	Replace batteries
	No communication between remote control and IFC module	Reprogram remote control to IFC module
	A maximum number of failed ignitions or flame restorations has been reached	Reset IFC module

14.0 MAINTENANCE

ATTENTION: Installation and repair shall only be done by a qualified service person. The appliance should be inspected before use by a qualified service person. This appliance is required to be inspected at least once a year by a professional service person.

WARNING: The appliance area must be kept clear and free from combustible materials, gasoline and other flammable vapors and liquids.

IMPORTANT: The compartment below the firebox must be cleaned at least once a year. More frequent cleaning may be required due to excessive lint from carpeting, bedding materials, etc. It is imperative that the control compartments and circulation air passageways of the appliance be kept clean. Use a vacuum to clean all components.

14.1 Burner and Pilot System

The burner assembly may be removed for easier access. Refer to 9.4 Control Board Removal and Installation on page 22.

Performed by: Qualified Service Person

Frequency: Annually

Action:

- Vacuum all components of the burner system.
- Visually check burner ports for blockage, especially near the pilot.
- Visually check pilot light and burner flame pattern when in operation. Flames should be steady, not lifting or floating.

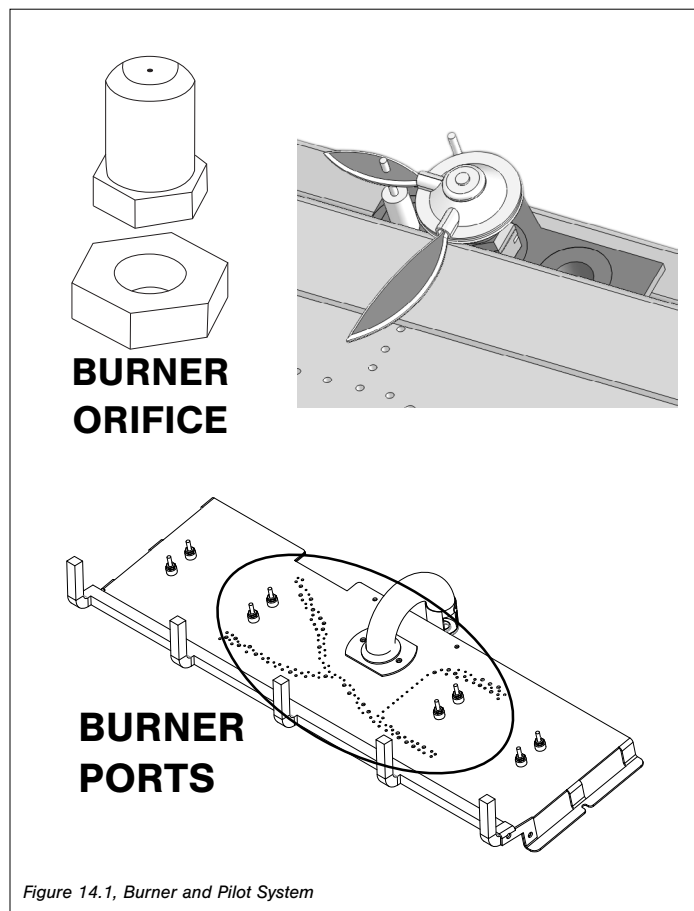

Figure 14.1, Burner and Pilot System

14.2 Fans

CAUTION: Label all wires prior to disconnection when servicing controls. Wiring errors can cause improper and dangerous operation. Verify proper operation after servicing.

Performed by: Qualified Service Person

Frequency: Every 6 months

Action:

- Disconnect the fans from electrical current and vacuum.
- The bearings are sealed and require no oiling.

14.3 Vent System

NOTE: If the vent-air intake system is disassembled for any reason, reinstall per instructions provided with installation. Refer to 6.0 Installation on page 14.

Performed by: Qualified Service Person

Frequency: Annually

Action:

- Examination of the vent system is required.
- The flow of combustion and ventilation air must not be obstructed.

14.4 Glass Assembly

CAUTION: Do not operate appliance with the glass assembly removed, cracked, or broken. Use protective gloves to handle any broken or damaged glass assembly components. DO NOT SUBSTITUTE MATERIALS.

WARNING: Avoid striking or slamming glass assembly. Avoid abrasive cleaner. DO NOT clean glass while it is hot.

Performed by: Homeowner

Frequency: Annually

Action:

- Prepare a work area large enough to accommodate the glass assembly on a flat, stable surface.
- Remove safety screen and glass frame assembly.
- Clean glass with a soft cloth and a non-abrasive cleaner.
- Reinstall glass assembly and safety screen.
- Any safety screen, guard, or barrier removed for servicing the appliance must be replaced prior to operating the appliance.

Performed by: Qualified Service Person

Frequency: Annually

Action:

- Inspect the glass for cracks, scratches, and nicks.
- Verify the glass assembly is properly intact and not damaged.
- Replace the glass and the assembly #701-001T as necessary.
- Only Hussong Mfg. Co., Inc. will supply the replacement of glass assembly as a complete unit.

15.0 REPLACEMENT PARTS LIST

Replacement parts are available through your local dealer. Contact your local dealer for availability and pricing.

CONTROL BOARD AND PARTS			
Control Board - NG	CK34L-150	Pilot Orifice - LPG	700-168
Control Board - LPG	CK34L-151	Valve Step Motor - NG	700-504
S.I.T. IPI Gas Valve - NG	700-567	Valve Step Motor - LPG	700-504-1
S.I.T. IPI Gas Valve - LPG	700-567-1	18 in. Flexible Gas Line - Black	700-213B
Proflame 2 IFC Board	700-652	Flexible Gas Line - Valve to Burner Connection	700-226
IFC Wire Harness Assembly	700-653	NG Burner Orifice #38	700-238
Pilot Assembly - NG	700-551	LPG Burner Orifice #52	700-252
Pilot Assembly - LPG	700-551-1	Conversion Kit - NG	NCK-CK34L-S
Transmitter (Remote Control)	700-408	Conversion Kit - LPG	LCK-CK34L-S
Pilot Orifice - NG	700-094	Burner Assembly	CK34L-135

GLASS AND GLASS GASKET	
31½" x 19⅝" Glass with tadpole gasket	701-001T
Tadpole Glass Gasket	900-006

SAFETY BARRIERS	
Beveled Screen Front	CK34-BSF
Convex Screen Front	CK34-CXF
Prairie Screen Front	CK34-PSF
Rectangular Screen Front	CK34-RSF
Arched Mission Screen Front	CK34A-MSF
Arched Prairie Screen Front	CK34A-PSF
Arched Screen Front	CK34A-SF
Arched Full Prairie Door Screen Front	CK34A-FPDSF

REFRACTORY PANELS	
(3 piece) Refractory Panel Set	CK34-I900
Back Refractory Panel	CK34-I900B
Left Side Refractory Panel	CK34-I900L
Right Side Refractory Panel	CK34-I900R

ENAMEL PANELS	
Enamel Firebox Panels (Black)	CK34-B900

ROCK KIT	
25 Piece Rock Set	CK34-R500
Rock Plate	CK34-R35
R1 Rock	R1
R2 Rock	R2
R3 Rock	R3
R5 Rock	R5
R6 Rock	R6
R7 Rock	R7
R8 Rock	R8
RX10 Rock	RX10
RX11 Rock	RX11

Hussong Manufacturing Co., Inc.
P.O. Box 577
204 Industrial Park Drive
Lakefield, MN 56150-0577
USA
CSK-34-R

LIMITED WARRANTY

Kozy Heat Limited 10 Year Warranty

This limited 10 Year Warranty will not become effective until the Warranty Registration Form has been completed and mailed to Hussong Manufacturing Co., Inc., P.O. Box 577, Lakefield, MN 56150. This registration form must be received within 30 days of installation. Failure to do so may result in delayed warranty coverage and submission of proof of purchase will be required.

Hussong Manufacturing Co., Inc. warrants to the original purchaser of this Kozy Heat Fireplace, that it is free of defects in materials and workmanship at the time of manufacture.

Subject to the following conditions & requirements, Hussong Manufacturing Co., Inc. extends the following limited warranty under normal use and service, with respect to the Kozy Heat line of gas burning fireplaces.

Year 1

Subject to the conditions & requirements listed below, within the first year from date of purchase, Hussong Manufacturing Co., Inc. shall, at its discretion, replace or repair any such defect in material or workmanship, at Hussong Manufacturing Co., Inc.'s expense, including reasonable labor costs to repair or replace the defective component, if a factory pre-authorization is given for the repair.

Years 2 through 10

Subject to the conditions & requirements listed below, beginning with the first day of the second year and continuing through the tenth year, Hussong Manufacturing Co., Inc., will at its discretion, provide repair or replacement parts at current list prices for any defect in material or workmanship of components, including optional components and accessories (if available). Hussong Manufacturing Co., Inc. shall not be responsible for any installation, labor, transportation of other indirect costs.

Limitation of Liability

To make a claim under this warranty, the purchaser must first contact the dealer/installer from whom the fireplace was purchased.

This limited warranty will be void if the fireplace is not installed by a qualified installer and according to the installation instructions. Use of unauthorized components will make this warranty null and void.

This limited warranty also is void if the fireplace is not operated, at all times, according to the operating instructions furnished.

This warranty is limited to defects in material and workmanship. It does not apply to any product that has been subject to negligence, misapplication, improper installation.

No person is authorized to extend the time of this warranty or to accept on Hussong Manufacturing Co., Inc.'s behalf any additional obligation of liability connected with the unit.

It is expressly agreed and understood that this warranty is Hussong Manufacturing Co., Inc.'s sole obligation and purchaser's exclusive remedy for defective fireplace equipment. Hussong Manufacturing Co., Inc. shall not be liable for any consequential, incidental or contingent damages whatsoever. The foregoing warranty is exclusive and in lieu of all other expressed warranties. Hussong Manufacturing Co., Inc. shall not be held to implied warranties or merchantability and fitness for a particular purpose. This warranty replaces all previous warranty policies.

Some states do not allow the exclusion or limitation of incidental or consequential damages or limitations on how long an implied warranty lasts, so the above limitations or exclusions may not apply to you. This warranty gives you specific legal rights and you may also have other rights which vary from state to state.

Hussong Manufacturing Co., Inc. reserves the right to make changes at any time, without notice, in design, material, specifications and prices. Hussong Manufacturing Co., Inc. reserves the right to discontinue models and products.

December 2014

Warranty Conditions and Requirements

1. You are the original purchaser. This warranty is not transferable.
2. Installation of the fireplace is performed by a qualified installer.
3. Installation and operation must comply with installation and operation instructions.
4. Paint and glass gaskets are covered for 30 days from date of purchase.
5. Remote controls and all optional accessories are covered for 1 year from date of purchase.
6. This warranty does not offer coverage for Light Bulbs, Batteries or Fuses (whether factory, dealer or installer supplied). This includes any damage stemming from either component's nonuse.
7. Components broken, (including glass panels), during shipping, careless handling of components, or defects resulting from improper installation, misuse of the fireplace and components are not covered under this warranty.
8. This warranty does not cover any part of the fireplace or any components which have been exposed to or submerged underwater.
9. Hussong Manufacturing Co., Inc. must be notified by the dealer the fireplace was purchased from or a qualified installer/service technician of the defect.
10. Annual service of the fireplace as required in the installation manual, is performed by a qualified installer/service technician. (Copies of such service records may be required to claim a warranty).
11. All previous warranty/service has been performed by a qualified installer or service technician. (Copies of such service records may be required to claim a warranty).

LIFETIME WARRANTY

LIFETIME WARRANTY COVERAGE WILL BE EXTENDED AS DESCRIBED BELOW PROVIDED ALL WARRANTY CONDITIONS AND REQUIREMENTS ARE MET AS OUTLINED IN THE 10 YEAR LIMITED WARRANTY POLICY.

Lifetime Warranty Coverage

LIFETIME WARRANTY IS EXTENDED AS FOLLOWS:

Hussong Manufacturing Co., Inc. warrants to the original purchaser that the firebox, heat exchanger, fiber logs, burner tube and glass panel of this Kozy Heat Fireplace will not be defective in material or workmanship under normal use and service for as long as you own this product. If any of these components fail due to defects in material and workmanship under normal use and service, Hussong Manufacturing Co., Inc. will, at its sole discretion, repair or replace the defective component. This LIFETIME WARRANTY does not cover any installation, labor, transportation or other indirect cost arising from defective components.

Limitation of Liability

This Lifetime Warranty will be void if the fireplace is not installed by a qualified installer and according to the installation instructions. Use of unauthorized components will make this warranty null and void. This Lifetime Warranty also is void if the fireplace is not operated, at all times, according to the operating instructions furnished. This warranty is limited to defects in material and workmanship of components specified. It does not apply to any product that has been subject to negligence, misapplication, improper installation.

No person is authorized to extend the time of this Lifetime Warranty or to accept on Hussong Manufacturing Co., Inc.'s behalf any additional obligation of liability connected with the unit.

Hussong Manufacturing Co., Inc. may fully discharge all obligations with respect to this Lifetime Warranty by refunding the wholesale price of the defective component(s).

It is expressly agreed and understood that this Lifetime Warranty is Hussong Manufacturing Co., Inc.'s sole obligation and original purchaser's exclusive remedy for defective fireplace equipment. Hussong Manufacturing Co., Inc. shall not be liable for any consequential, incidental or contingent damages whatsoever other than those incurred by Hussong Manufacturing Co., Inc. to repair or replace the defective component. The foregoing warranty is exclusive and in lieu of all other expressed warranties. Hussong Manufacturing Co., Inc. shall not be held to implied warranties, including but not limited to the implied warranties or merchantability and fitness for a particular purpose. This lifetime warranty replace all previous lifetime warranty policies.

Hussong Manufacturing Co., Inc. reserves the right to make changes at any time, without notice, in design, material, specifications and prices. Hussong Manufacturing Co., Inc. reserves the right to discontinue models and products.

To activate this Lifetime Warranty coverage, this registration card must be completed and mailed with your completed 10 Year Limited Warranty form within 30 days of installation to the following address:

**Hussong Manufacturing Co., Inc.
P.O. Box 577
204 Industrial Park Drive
Lakefield, MN 56150-0577**

September 2011

CUT ALONG DOTTED LINE

PURCHASER NAME: _____

ADDRESS: _____

TELEPHONE: _____

INSTALLER NAME: _____

ADDRESS: _____

TELEPHONE: _____

INSTALLATION DATE: _____

MODEL NUMBER: _____

SERIAL NUMBER: _____

